

USER'S MANUAL

SYSDRIVE 3G3MV

Multi-function Compact Inverter

Thank you for choosing this SYSDRIVE 3G3MV-series product. Proper use and handling of the product will ensure proper product performance, will lengthen product life, and may prevent possible accidents.

Please read this manual thoroughly and handle and operate the product with care.

NOTICE

1. This manual describes the functions of the product and relations with other products. You should assume that anything not described in this manual is not possible.
2. Although care has been given in documenting the product, please contact your OMRON representative if you have any suggestions on improving this manual.
3. The product contains potentially dangerous parts under the cover. Do not attempt to open the cover under any circumstances. Doing so may result in injury or death and may damage the product. Never attempt to repair or disassemble the product.
4. We recommend that you add the following precautions to any instruction manuals you prepare for the system into which the product is being installed.
 - Precautions on the dangers of high-voltage equipment.
 - Precautions on touching the terminals of the product even after power has been turned off. (These terminals are live even with the power turned off.)
5. Specifications and functions may be changed without notice in order to improve product performance.

Items to Check Before Unpacking

Check the following items before removing the product from the package:

- Has the correct product been delivered (i.e., the correct model number and specifications)?
- Has the product been damaged in shipping?
- Are any screws or bolts loose?

OMRON

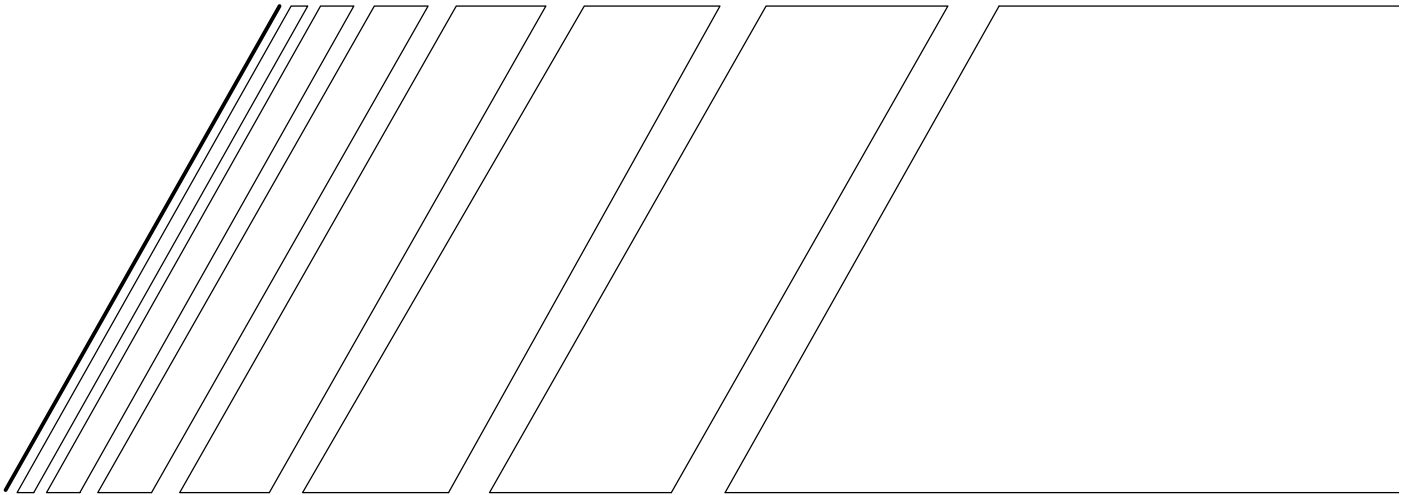

USER'S MANUAL

SYSDRIVE 3G3MV SERIES

Multi-function Compact Inverter

Checking Before Unpacking

■ Checking the Product

On delivery, always check that the delivered product is the SYSDRIVE 3G3MV Inverter that you ordered.

Should you find any problems with the product, immediately contact your nearest local sales representative.

● Checking the Nameplate

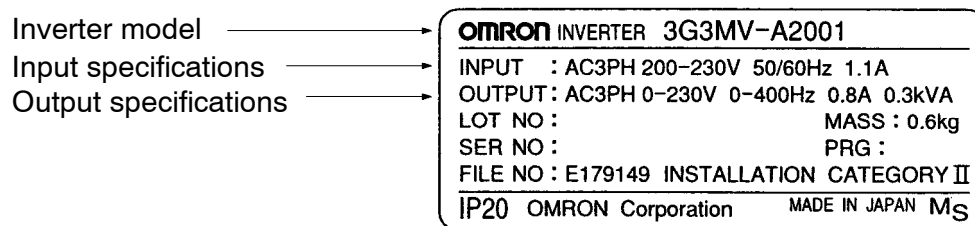

● Checking the Model

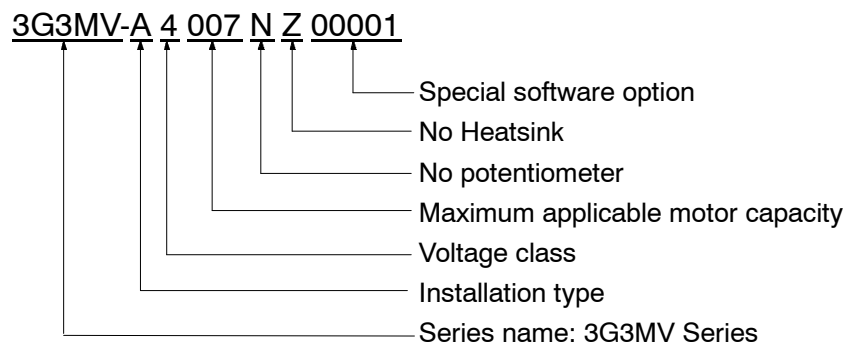

Installation Type

A	Closed wall mounting
---	----------------------

Voltage Class

2	Three-phase 200-VAC input (200-V class)
B	Single-phase 200-VAC input (200-V class)
4	Three-phase 400-VAC input (400-V class)

Maximum Applicable Motor Capacity

001	0.1 (0.1) kW
002	0.2 (0.25/0.37) kW
004	0.4 (0.55) kW
007	0.75 (1.1) kW
015	1.5 (1.5) kW
022	2.2 (2.2) kW
030	3.0 (3.0) kW
040	4.0 (4.0) kW
055	5.5 (5.5) kW
075	7.5 (7.5) kW

Note The figures in parentheses indicate capacities for motors used outside Japan.

Front Cover options

B	Blank cover
N	No potentiometer

Heatsink option

Z	No Heatsink
---	-------------

● Checking for Damage

Check the overall appearance and check for damage or scratches resulting from transportation.

Warning Labels

Warning labels are pasted on the product as shown in the following illustration. Be sure to follow the instructions given there.

■ Warning Labels

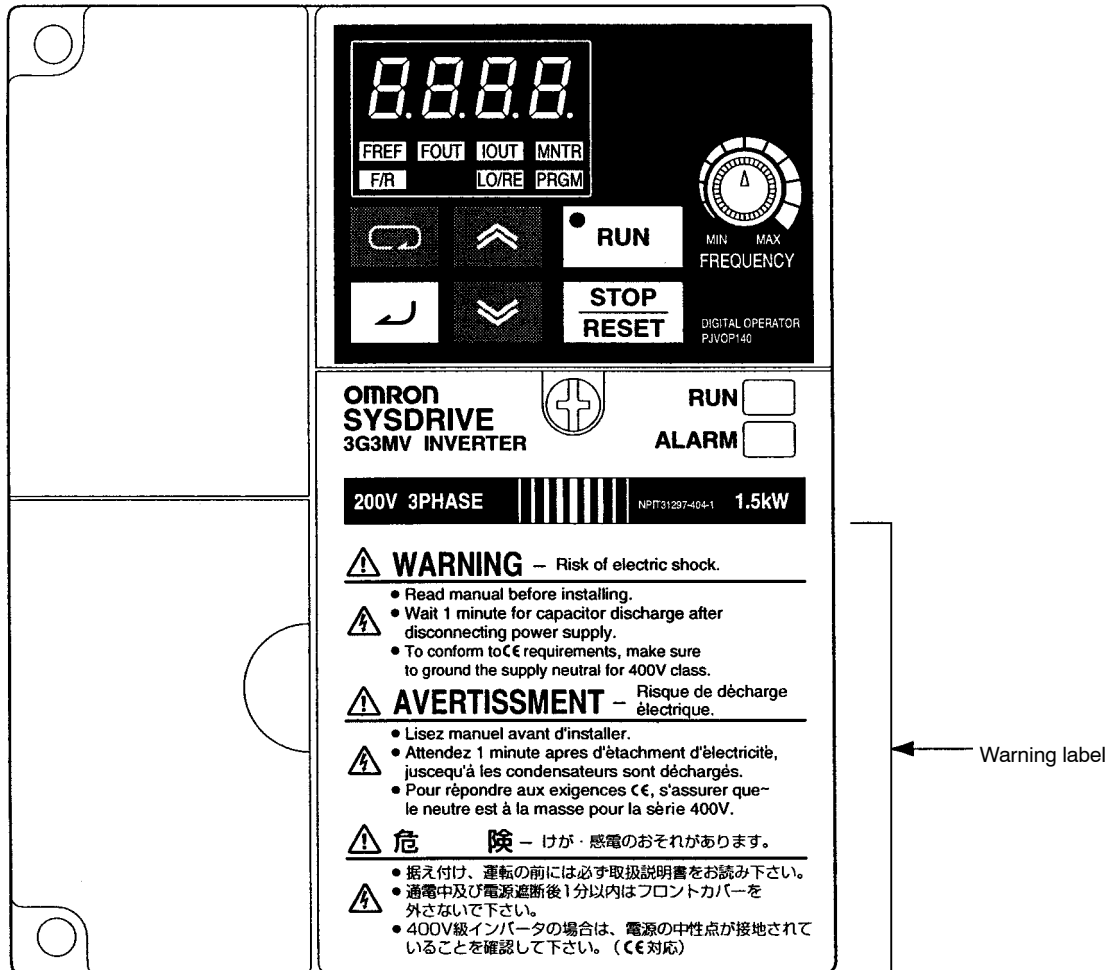

■ Contents of Warning

⚠ WARNING – Risk of electric shock.

- Read manual before installing.
- Wait 1 minute for capacitor discharge after disconnecting power supply.
- To conform to CE requirements, make sure to ground the supply neutral for 400V class.

⚠ AVERTISSEMENT – Risque de décharge électrique.

- Lisez manuel avant d'installer.
- Attendez 1 minute apres d'etachment d'electricite, jusquequ'à les condensateurs sont déchargés.
- Pour répondre aux exigences CE, s'assurer que le neutre est à la masse pour la série 400V.

⚠ 危険 – けが・感電のおそれがあります。

- 据え付け、運転の前には必ず取扱説明書をお読み下さい。
- 通電中及び電源遮断後1分以内はフロントカバーを外さないで下さい。
- 400V級インバータの場合は、電源の中性点が接地されていることを確認して下さい。(CE対応)

 **WARNING** Be sure confirm that the RUN signal is turned OFF before turning ON the power supply, resetting the alarm, or switching the LOCAL/REMOTE selector. Doing so while the RUN signal is turned ON may result in injury.

 **Caution** Be sure to confirm permissible ranges of motors and machines before operation because the Inverter speed can be easily changed from low to high. Not doing so may result in damage to the product.

 **Caution** Provide a separate holding brake when necessary. Not doing so may result in injury.

 **Caution** Do not perform a signal check during operation. Doing so may result in injury or damage to the product.

 **Caution** Do not carelessly change settings. Doing so may result in injury or damage to the product.

Maintenance and Inspection Precautions

 **WARNING** Do not touch the Inverter terminals while the power is being supplied.







 **WARNING** Maintenance or inspection must be performed only after turning OFF the power supply, confirming that the CHARGE indicator (or status indicators) is turned OFF, and after waiting for the time specified on the front cover. Not doing so may result in electrical shock.

 **WARNING** Maintenance, inspection, or parts replacement must be performed by authorized personnel. Not doing so may result in electrical shock or injury.







 **WARNING** Do not attempt to take the Unit apart or repair. Doing either of these may result in electrical shock or injury.

 **Caution** Carefully handle the Inverter because it uses semiconductor elements. Careless handling may result in malfunction.



 **Caution** Do not change wiring, disconnect connectors or Operator, or replace fans while power is being supplied. Doing so may result in injury or malfunction.

-  **Caution** Install external breakers and take other safety measures against short-circuiting in external wiring. Not doing so may result in fire.
-  **Caution** Confirm that the rated input voltage of the Inverter is the same as the AC power supply voltage. An incorrect power supply may result in fire, injury, or malfunction.
-  **Caution** If you use a Braking Resistor or a Braking Resistor Unit, connect them as specified in the manual. Not doing so may result in fire.
-  **Caution** Be sure to wire correctly and securely. Not doing so may result in injury or damage to the product.
-  **Caution** Be sure to firmly tighten the screws on the terminal block. Not doing so may result in fire, injury, or damage to the product.
-  **Caution** Do not connect an AC power to the U, V, or W output. Doing so may result in damage to the product or malfunction.





Operation and Adjustment Precautions

-  **WARNING** Turn ON the input power supply only after mounting the front cover, terminal covers, bottom cover, Operator, and optional items. Not doing so may result in electrical shock.
-  **WARNING** Do not remove the front cover, terminal covers, bottom cover, Operator, or optional items while the power is being supplied. Not doing so may result in electrical shock.
-  **WARNING** Do not operate the Operator or switches with wet hands. Doing so may result in electrical shock.
-  **WARNING** Do not touch the inside of the Inverter. Doing so may result in electrical shock.
-  **WARNING** Do not come close to the machine when using the error retry function because the machine may abruptly start when stopped by an alarm. Doing so may result in injury.
-  **WARNING** Do not come close to the machine immediately after resetting momentary power interruption to avoid an unexpected restart (if operation is set to be continued in the processing selection function after momentary power interruption is reset). Doing so may result in injury.
-  **WARNING** Provide a separate emergency stop switch because the STOP Key on the Operator is valid only when function settings are performed. Not doing so may result in injury.





Transportation Precautions

-  **Caution** Do not hold by front cover or panel, instead, hold by the radiation fin (heat sink) while transporting the product. Doing so may result in injury.
-  **Caution** Do not pull on the cables. Doing so may result in damage to the product or malfunction.
-  **Caution** Use the eye-bolts only for transporting the Inverter. Using them for transporting the machinery may result in injury or malfunction.

Installation Precautions

-  **Caution** Be sure to install the product in the correct direction and provide specified clearances between the Inverter and control panel or with other devices. Not doing so may result in fire or malfunction.
-  **Caution** Do not allow foreign objects to enter inside the product. Doing so may result in fire or malfunction.
-  **Caution** Do not apply any strong impact. Doing so may result in damage to the product or malfunction.
-  **Caution** Provide an appropriate stopping device on the machine side to secure safety. (A holding brake is not a stopping device for securing safety.) Not doing so may result in injury.
-  **Caution** Provide an external emergency stopping device that allows an instantaneous stop of operation and power interruption. Not doing so may result in injury.

Wiring Precautions









-  **WARNING** Wiring must be performed only after confirming that the power supply has been turned OFF. Not doing so may result in electrical shock.
-  **WARNING** Wiring must be performed by authorized personnel. Not doing so may result in electrical shock or fire.
-  **WARNING** Be sure to confirm operation only after wiring the emergency stop circuit. Not doing so may result in injury.
-  **WARNING** Always connect the ground terminals to a ground of 100 Ω or less for the 200-VAC class, or 10 Ω or less for the 400-VAC class. Not connecting to a proper ground may result in electrical shock.

General Precautions

Observe the following precautions when using the SYSDRIVE Inverters and peripheral devices.

This manual may include illustrations of the product with protective covers removed in order to describe the components of the product in detail. Make sure that these protective covers are on the product before use.

Consult your OMRON representative when using the product after a long period of storage.

-  **WARNING** Do not touch the inside of the Inverter. Doing so may result in electrical shock.
-  **WARNING** Operation, maintenance, or inspection must be performed after turning OFF the power supply, confirming that the CHARGE indicator (or status indicators) are OFF, and after waiting for the time specified on the front cover. Not doing so may result in electrical shock.
-  **WARNING** Do not damage, pull on, apply stress to, place heavy objects on, or pinch the cables. Doing so may result in electrical shock.
-  **WARNING** Do not touch the rotating parts of the motor under operation. Doing so may result in injury.
-  **WARNING** Do not modify the product. Doing so may result in injury or damage to the product.
-  **Caution** Do not store, install, or operate the product in the following places. Doing so may result in electrical shock, fire or damage to the product.
 - Locations subject to direct sunlight.
 - Locations subject to temperatures or humidity outside the range specified in the specifications.
 - Locations subject to condensation as the result of severe changes in temperature.
 - Locations subject to corrosive or flammable gases.
 - Locations subject to exposure to combustibles.
 - Locations subject to dust (especially iron dust) or salts.
 - Locations subject to exposure to water, oil, or chemicals.
 - Locations subject to shock or vibration.
-  **Caution** Do not touch the Inverter radiator, regenerative resistor, or Servomotor while the power is being supplied or soon after the power is turned OFF. Doing so may result in a skin burn due to the hot surface.
-  **Caution** Do not conduct a dielectric strength test on any part of the Inverter. Doing so may result in damage to the product or malfunction.
-  **Caution** Take appropriate and sufficient countermeasures when installing systems in the following locations. Not doing so may result in equipment damage.
 - Locations subject to static electricity or other forms of noise.
 - Locations subject to strong electromagnetic fields and magnetic fields.
 - Locations subject to possible exposure to radioactivity.
 - Locations close to power supplies.

Notice:

OMRON products are manufactured for use according to proper procedures by a qualified operator and only for the purposes described in this manual.

The following conventions are used to indicate and classify precautions in this manual. Always heed the information provided with them. Failure to heed precautions can result in injury to people or damage to property.

 **DANGER** Indicates an imminently hazardous situation which, if not avoided, will result in death or serious injury.

 **WARNING** Indicates a potentially hazardous situation which, if not avoided, could result in death or serious injury.

 **Caution** Indicates a potentially hazardous situation which, if not avoided, may result in minor or moderate injury, or property damage.

OMRON Product References

All OMRON products are capitalized in this manual. The word “Unit” is also capitalized when it refers to an OMRON product, regardless of whether or not it appears in the proper name of the product.

The abbreviation “Ch,” which appears in some displays and on some OMRON products, often means “word” and is abbreviated “Wd” in documentation in this sense.

The abbreviation “PC” means Programmable Controller and is not used as an abbreviation for anything else.

Visual Aids

The following headings appear in the left column of the manual to help you locate different types of information.

Note Indicates information of particular interest for efficient and convenient operation of the product.

© OMRON, 2001

All rights reserved. No part of this publication may be reproduced, stored in a retrieval system, or transmitted, in any form, or by any means, mechanical, electronic, photocopying, recording, or otherwise, without the prior written permission of OMRON.

No patent liability is assumed with respect to the use of the information contained herein. Moreover, because OMRON is constantly striving to improve its high-quality products, the information contained in this manual is subject to change without notice. Every precaution has been taken in the preparation of this manual. Nevertheless, OMRON assumes no responsibility for errors or omissions. Neither is any liability assumed for damages resulting from the use of the information contained in this publication.

Table of Contents

Chapter 1. Overview	1-1
1-1 Function	1-2
1-2 Nomenclature	1-5
1-3 New Features	1-8
Chapter 2. Design	2-1
2-1 Installation	2-2
2-1-1 Dimensions	2-2
2-1-2 Installation Conditions	2-6
2-1-3 Removing and Mounting the Covers	2-8
2-2 Wiring	2-11
2-2-1 Terminal Block	2-12
2-2-2 Standard Connections	2-20
2-2-3 Wiring around the Main Circuit	2-21
2-2-4 Wiring Control Circuit Terminals	2-38
2-2-5 Conforming to EC Directive	2-41
Chapter 3. Preparing for Operation and Monitoring	3-1
3-1 Nomenclature	3-2
3-1-1 Names of Parts and their Functions	3-2
3-1-2 Outline of Operation	3-3
3-2 Parameter Copy and Verify Function	3-10
3-2-1 Parameter for Copying and Verifying Set Values	3-10
3-2-2 Parameter Copying Procedure	3-11
3-2-3 Parameter Read-prohibit Selection (Prohibiting Data Written to the EEPROM of the Digital Operator)	3-18
3-2-4 Parameter Copy or Verify Errors	3-19
Chapter 4. Test Run	4-1
4-1 Procedure for Test Run	4-4
4-2 Operation Example	4-6
Chapter 5. Basic Operation	5-1
5-1 Initial Settings	5-2
5-1-1 Setting the Parameter Write-prohibit Selection/Parameter Initialization (n001)	5-2
5-1-2 Setting the Control Mode (n002)	5-3
5-2 Operation in Vector Control	5-5
5-3 Operation in V/f Control	5-7
5-3-1 Setting the Rated Motor Current (n036)	5-7
5-3-2 Setting the V/f Patterns (n011 to n017)	5-7
5-4 Setting the Local/Remote Mode	5-10
5-5 Selecting the Operation Command	5-11

Table of Contents

5-6	Setting the Frequency Reference	5-12
5-6-1	Selecting the Frequency Reference	5-12
5-6-2	Upper and Lower Frequency Reference Limits	5-13
5-6-3	Frequency Referencing by Analog Input	5-14
5-6-4	Setting Frequency References through Key Sequences	5-19
5-6-5	Setting Frequency References by Pulse Train Input	5-25
5-7	Setting the Acceleration/Deceleration Time	5-27
5-8	Selecting the Reverse Rotation-prohibit	5-30
5-9	Selecting the Stopping Mode	5-31
5-10	Multi-function I/O	5-32
5-10-1	Multi-function Input	5-32
5-10-2	Multi-function digital Output	5-38
5-11	Multi-function Analog Output and Pulse Monitor Output	5-41
5-11-1	Setting the Multi-function Analog Output (n065 through n067) ...	5-41
5-11-2	Setting the Pulse Monitor Output (n065 and n150)	5-42

Chapter 6. Advanced Operation **6-1**

6-1	Precise Vector Control Settings and Adjustments	6-2
6-1-1	Precise Vector Control Settings	6-2
6-1-2	Adjusting Output Torque in Vector Control	6-3
6-2	Energy-saving Control	6-6
6-2-1	Energy-saving Control Operation	6-6
6-2-2	Performing Energy-saving Settings	6-7
6-3	PID Control	6-13
6-3-1	PID Control Applications	6-13
6-3-2	PID Control Operation	6-14
6-3-3	Types of PID Control	6-14
6-3-4	Block Diagram of PID Control	6-16
6-3-5	Input Selection of PID Control Target Value and Detection Value .	6-17
6-3-6	PID Control Settings	6-18
6-3-7	PID Adjustments	6-22
6-3-8	PID Fine Tuning	6-24
6-4	Setting the Carrier Frequency	6-26
6-5	DC Injection Braking Function	6-29
6-6	Stall Prevention Function	6-31
6-7	Overtorque Detection Function	6-35
6-8	Torque Compensation Function	6-37
6-9	Slip Compensation Function	6-39
6-10	Other Functions	6-41
6-10-1	Digital Operator Disconnection Error Detection	6-41
6-10-2	Motor Protection Functions (n037 and n038)	6-41
6-10-3	Cooling Fan Operation Function (n039)	6-42
6-10-4	Momentary Power Interruption Compensation (n081)	6-42
6-10-5	Fault Retry (n082)	6-43
6-10-6	Frequency Jump Function (n083 to n086)	6-44

Table of Contents

6-10-7	Accumulated Operating Time (n087, n088)	6-45
6-10-8	Frequency Detection Function	6-46
6-10-9	UP/DOWN Command Frequency Memory (n100)	6-48
6-10-10	Input Open-phase Detection (n166, n167)	6-50
6-10-11	Output Open-phase Detection (n168, n169)	6-51
6-10-12	Fault Log (n178)	6-52

Chapter 7. Communications **7-1**

7-1	Inverter Settings	7-2
7-1-1	Setting the Communications Conditions	7-2
7-1-2	RUN Command Selection (n003)	7-6
7-1-3	Frequency Reference Input Selection (n004)	7-6
7-1-4	Setting the Multi-function Inputs (n050 to n056)	7-7
7-2	Message Communications Basic Formats	7-9
7-3	DSR Message and Response	7-12
7-3-1	Data Read (Function Code: 03 Hex)	7-12
7-3-2	Data Write/Broadcast Data Write (Function Code: 10 Hex)	7-15
7-3-3	Loop-back Test (Function Code: 08 Hex)	7-17
7-4	Enter Command	7-20
7-5	Setting the Communications Data	7-21
7-6	Register Number Allocations in Detail	7-23
7-6-1	I/O Function	7-23
7-6-2	Monitor Functions	7-25
7-7	Communications Error Codes	7-30
7-8	Self-diagnostic Test	7-32
7-9	Communications with Programmable Controller	7-33
7-9-1	Available Programmable Controller and Peripheral Device	7-33
7-9-2	Wiring the Communications Line	7-36
7-9-3	Outline of Protocol Macro Function	7-37
7-9-4	Creating a Project File	7-42
7-9-5	Ladder Program	7-52
7-9-6	Communications Response Time	7-57

Chapter 8. Maintenance Operations **8-1**

8-1	Protective and Diagnostic Functions	8-2
8-1-1	Fault Detection (Fatal Error)	8-2
8-1-2	Warning Detection (Nonfatal Error)	8-11
8-2	Troubleshooting	8-18
8-2-1	Parameters Fail Set	8-18
8-2-2	Motor Fails to Operate	8-18
8-2-3	Motor Rotates in the Wrong Direction	8-21
8-2-4	Motor Outputs No Torque or Acceleration is Slow	8-21
8-2-5	Speed Accuracy of the Inverter Rotating at High Speed in Vector Control is Low	8-22
8-2-6	Motor Deceleration Rate is Low	8-22

Table of Contents

8-2-7	Vertical-axis Load Drops when Brakes are Applied	8-22
8-2-8	Motor Burns	8-23
8-2-9	Controller or AM Radio Receives Noise when Inverter is Started .	8-24
8-2-10	Ground Fault Interrupter is Actuated when Inverter is Started	8-24
8-2-11	Mechanical Vibration	8-25
8-2-12	Stable PID Control is Not Possible or Control Fails	8-26
8-2-13	Inverter Vibrates in Energy-saving Control	8-26
8-2-14	Motor Rotates after Output of Inverter is Turned OFF	8-27
8-2-15	Detects 0 V and Stalls when Motor Starts	8-27
8-2-16	Output Frequency Does Not Reach Frequency Reference	8-27
8-2-17	Inverter Does Not Run Because EF (Simultaneous Inputs of Forward and Reverse Commands) is Detected, Or Motor Rotates Momentarily When Control Device Power is Turned OFF	8-27
8-3	Maintenance and Inspection	8-29

Chapter 9. Specifications	9-1
--	------------

9-1	Inverter Specifications	9-2
9-2	Option Specifications	9-8
9-2-1	EMC-compatible Noise Filter	9-8
9-2-2	DIN Track Mounting Bracket	9-17
9-2-3	DC Reactor	9-19
9-2-4	AC Reactor	9-20
9-2-5	Output Noise Filter	9-22
9-2-6	CompoBus/D Communications Unit	9-24

Chapter 10. List of Parameters	10-1
---	-------------

Chapter 11. Using the Inverter for a Motor	11-1
---	-------------

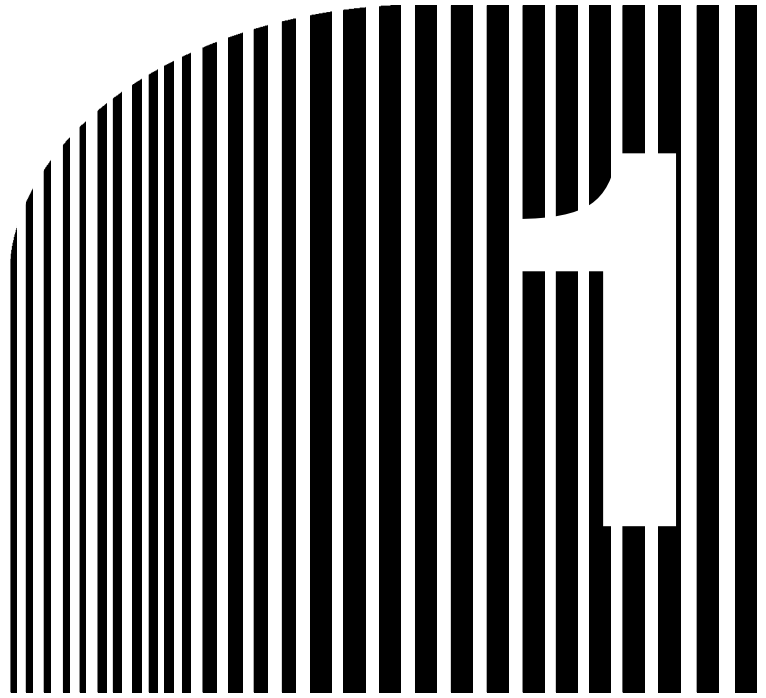

Chapter 1

• Overview •

1-1 Function

1-2 Nomenclature

1-1 Function

The high-function compact SYSDRIVE 3G3MV-Series Inverter is the first compact Inverter to feature open-loop vector control.

The 3G3MV Inverter meets EC Directives and UL/cUL standard requirements for worldwide use.

Furthermore, the 3G3MV-Series Inverter incorporates a variety of convenient control, network, and I/O functions that are versatile and easy-to-use.

■ SYSDRIVE 3G3MV Inverter Models

- The following 200-V-class (three- and single-phase 200-VAC types) and 400-V-class (three-phase 400-VAC type) 3G3MV models are available.

Rated voltage	Protective structure	Maximum applied motor capacity	Model
3-phase 200 VAC	Panel mounting type (conform to IP20)	0.1 (0.1) kW	3G3MV-A2001
		0.2 (0.25) kW	3G3MV-A2002
		0.4 (0.55) kW	3G3MV-A2004
		0.75 (1.1) kW	3G3MV-A2007
		1.5 (1.5) kW	3G3MV-A2015
		2.2 (2.2) kW	3G3MV-A2022
		4.0 (4.0) kW	3G3MV-A2040
	Closed wall mounting type (conform to NEMA1 and IP20)	5.5 (5.5) kW	3G3MV-A2055
		7.5 (7.5) kW	3G3MV-A2075
Single-phase 200 VAC	Panel mounting type (conforming to IP20)	0.1 (0.1) kW	3G3MV-AB001
		0.2 (0.25) kW	3G3MV-AB002
		0.4 (0.55) kW	3G3MV-AB004
		0.75 (1.1) kW	3G3MV-AB007
		1.5 (1.5) kW	3G3MV-AB015
		2.2 (2.2) kW	3G3MV-AB022
		4.0 (4.0) kW	3G3MV-AB040

3-phase 400 VAC	Panel mounting type (conform to IP20)	0.2 (0.37) kW	3G3MV-A4002
		0.4 (0.55) kW	3G3MV-A4004
		0.75 (1.1) kW	3G3MV-A4007
		1.5 (1.5) kW	3G3MV-A4015
		2.2 (2.2) kW	3G3MV-A4022
		3.0 (3.0) kW	3G3MV-A4030
		4.0 (4.0) kW	3G3MV-A4040
	Closed wall mounting type (conform to NEMA1 and IP20)	5.5 (5.5) kW	3G3MV-A4055
		7.5 (7.5) kW	3G3MV-A4075

Note The figures in parentheses indicate capacities for motors used outside Japan.

■ Powerful Torque Ideal for a Variety of Applications

The 3G3MV is OMRON's first compact Inverter incorporating an open-loop vector control function, which ensures a torque output that is 150% of the rated motor torque at an output frequency of 1 Hz.

Ensures a more powerful revolution at low frequencies than any conventional inverter. Furthermore, the 3G3MV Inverter suppresses the revolution fluctuation caused by the load.

Incorporates a fully automatic torque boost function that drives the motor powerfully in V/f control.

Incorporates a high-speed current limit function, thus suppressing overcurrent caused by high torque and ensuring smooth operation of the motor.

■ Convenient Easy-to-use Functions

- The FREQUENCY adjuster of the Digital Operator allows easy operation. The default setting is for operation according to the FREQUENCY adjuster setting.
- The Digital Operator has a parameter copy function ensuring easy parameter control.
- Ease of maintenance is ensured. The cooling fan is easily replaceable. The life of the cooling fan can be prolonged by turning ON the cooling fan only when the Inverter is in operation.
- Incorporates a braking transistor. Therefore, the Inverter will provide powerful control by just connecting a braking resistor.
- Incorporates an inrush current preventive circuit that prevents contact weld at the input power supply block.

■ **International Standards (EC Directives and UL/cUL Standards)**

The 3G3MV Inverter meets the EC Directives and UL/cUL standard requirements for worldwide use.

Classification		Applicable standard
EC Directives	EMC directive	EN50081-2 and EN50082-2
	Low-voltage directive	prEN50178
UL/cUL		UL508C

■ **Compatible with CompoBus/D and MODBUS RS-422/485**

- Supports RS-422 and RS-485 communications conforming to the MODBUS Communications Protocol, thus making it possible to easily construct networks with the use of the Protocol Macro or ASCII Unit mounted on an OMRON SYSMAC PC. The MODBUS Communications Protocol is a trademark of AEG Schneider Automation.
- Connects to the 3G3MV-PDRT1-SINV CompoBus/D Communications Unit. A remote I/O function for CompoBus/D communications is available to the 3G3MV Inverter, which ensures ease of communications just like standard I/O communications. Furthermore, CompoBus/D communications conform to the DeviceNet communications protocol for open networks, thus allowing construction of multi-vendor networks in which other companies' devices can coexist.

Note Modbus communication and CompoBus/D communication cannot be performed simultaneously. It is necessary to select the type of communication required.

■ **Handles a Variety of I/O Signals**

Handles a variety of I/O signals over a wide application range as described below.

- Analog voltage input: 0 to 10 V
- Analog current input: 4 to 20 or 0 to 20 mA
- Pulse train input: 0.1 to 33.0 kHz
- Multi-function analog output or pulse train output is selectable as monitor output

■ **Suppression of Harmonics**

Connects to DC reactors, thus suppressing harmonics more effectively than conventional AC reactors.

Further improvement in the suppression of harmonics is possible with the combined use of the DC and AC reactors.

1-2 Nomenclature

■ Panel

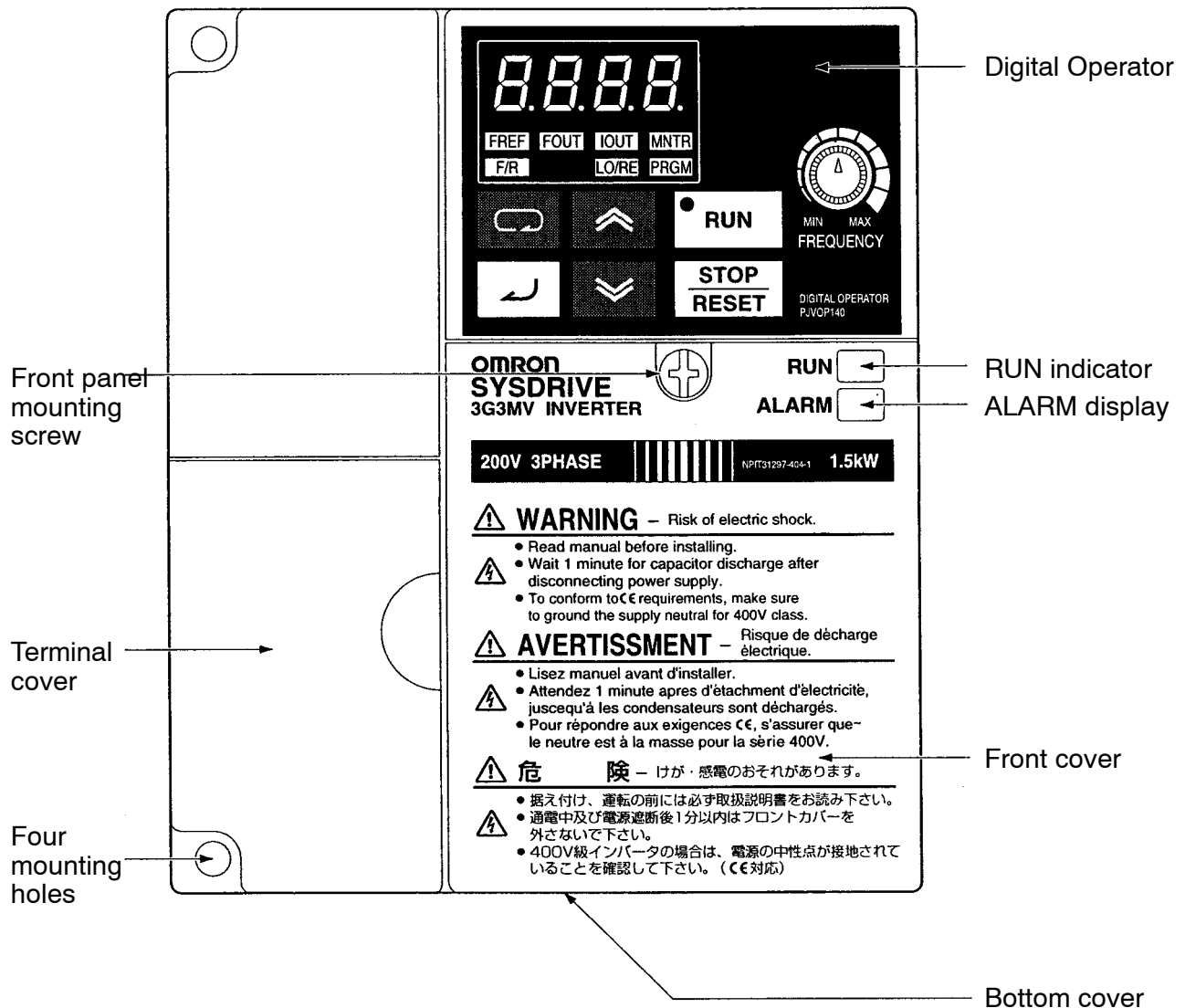

Note None of the following 200-V models have a terminal cover or mounting holes. Instead, the front cover is used as a terminal cover and two U-shaped cutouts are provided in place of the mounting holes.





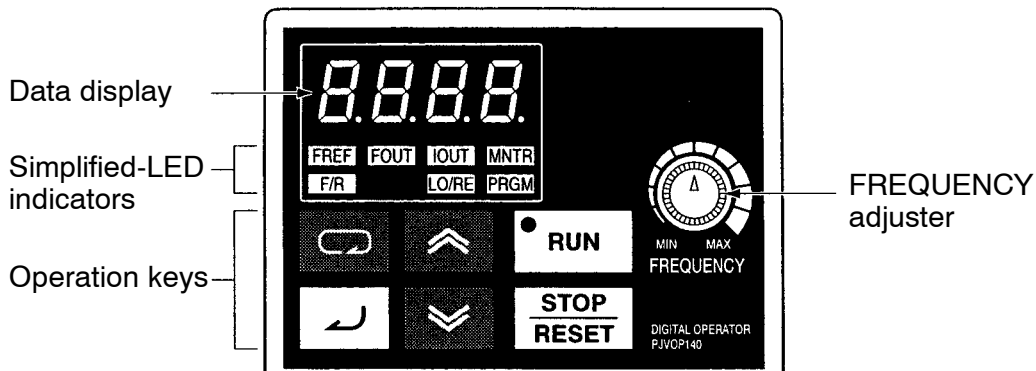

3G3MV-A2001 (0.1 kW), 3G3MV-A2002 (0.2 kW), 3G3MV-A2004 (0.4 kW), and 3G3MV-A2007 (0.75 kW)

3G3MV-AB001 (0.1 kW), 3G3MV-AB002 (0.2 kW), and 3G3MV-AB004 (0.4 kW)

■ Digital Operator



Appearance	Name	Function
	Data display	Displays relevant data items, such as frequency reference, output frequency, and parameter set values.
	FREQUENCY adjuster	Sets the frequency reference within a range between 0 Hz and the maximum output frequency.
	FREF indicator	The frequency reference can be monitored or set while this indicator is lit.
	FOUT indicator	The output frequency of the Inverter can be monitored while this indicator is lit.
	IOUT indicator	The output current of the Inverter can be monitored while this indicator is lit.
	MNTR indicator	The values set in U01 through U18 are monitored while this indicator is lit. Depending on the inverter capacity, the quantity of the Uxx will be different.
	F/R indicator	The direction of rotation can be selected while this indicator is lit when operating the Inverter with the RUN Key.
	LO/RE indicator	The operation of the Inverter through the Digital Operator or according to the set parameters is selectable while this indicator is lit. Note This status of this indicator can be only monitored while the Inverter is in operation. Any RUN command input is ignored while this indicator is lit.

Appearance	Name	Function
	PRGM indicator	The parameters in n001 through n179 can be set or monitored while this indicator is lit. Note While the Inverter is in operation, the parameters can be only monitored and only some parameters can be changed. Any RUN command input is ignored while this indicator is lit. Unless n001 is 5.
	Mode Key	Switches the simplified-LED (setting and monitor) item indicators in sequence. Parameter being set will be canceled if this key is pressed before entering the setting.
	Increment Key	Increases multi-function monitor numbers, parameter numbers, and parameter set values.
	Decrement Key	Decreases multi-function monitor numbers, parameter numbers, and parameter set values.
	Enter Key	Enters multi-function monitor numbers, parameter numbers, and internal data values after they are set or changed.
	RUN Key	Starts the Inverter running when the 3G3MV is in operation with the Digital Operator.
	STOP/RESET Key	Stops the Inverter unless parameter n007 is set to disable the STOP Key. Functions as a Reset Key when an inverter error occurs (see note).

Note For safety reasons, the reset will not work while a RUN command (forward or reverse) is in effect. Wait until the RUN command is OFF before resetting the Inverter.

1-3 New Features

New features have been added to 3G3MV-Series models with 5.5-kW and 7.5-kW capacities (i.e., the 3G3MV-A2055/A2075/ A4055/A4075). These features are outlined below and explained in detail in *Chapter 6*.

■ New Features for 3G3MV-A2055/A2075/ A4055/A4075 only

● Enclosure Rating: Closed Wall-mounting Conforming to IP20/NEMA1

The 5.5-kW and 7.5-kW Inverters have closed wall-mounting specifications that conform to IP20/NEMA1, so they can operate in an ambient temperature range of -10 to 40°C.

Note To operate this Inverter within an ambient temperature range of -10 to 50°C, remove the top and bottom covers to convert it to a panel-mounting model (IP00).

● Default Settings Changed for V/f Patterns (Parameters: n011 to n017)

For 5.5-kW and 7.5-kW Inverters, two of the default settings have been changed. The default settings for the middle output frequency voltage (VC) (n015) and the minimum output frequency voltage (VMIN (n017) have both been changed to 10 V for 200-V-class models and to 20 V for 400-V-class models.

● Inverter Overheating Warning Input (Parameters: n050 to n056; Fault Display: oH3)

An Inverter overheating warning input has been added as a new function that can be set for multi-function inputs 1 to 7 (n050 to n056). When this warning is input, an oH3 fault (nonfatal error, please check page 8-11) will be displayed. This input can be used for functions such as thermal contact connections for peripheral overheating detection.

● Frequency Reference Loss Detection (Parameter: n064)

When the frequency is referenced using analog frequency reference inputs (0 to 10 V/4 to 20 mA/0 to 20 mA), this function detects sudden changes in analog inputs as errors (disconnection, short circuit, breakdown, etc.) and outputs the frequency reference loss output that is set in multi-function outputs 1 to 3 (n057 to n059). After the change is detected, operation continues at 80% of the frequency reference prior to the change.

● Accumulated Operating Time (Monitor: U-13; Parameters: n087, n088)

This function calculates and stores in memory the Inverter's accumulated power-ON time or RUN time. Use it for checking and determining the maintenance schedule.

● Speed Search Adjustment (Parameters: n101, n102)

A function has been added for adjusting the speed search. (The speed search is a function for detecting and smoothly controlling the speed of a free running motor.) The speed search operating time and search level can be adjusted.

● Input Open-phase Detection (Parameters: n166, n167; Fault Display: PF)

This function detects the Inverter's input power supply open phase. Open phases are detected through main circuit voltage fluctuations, so this function can also be used for detecting abnormal voltage fluctuations in the input power supply voltage.

- **Output Open-phase Detection**
(Parameters: n168, n169; Fault Display: LF)

This function detects open phases between the Inverter output and the motor.

- **Ground Fault Detection (Fault Display: GF)**

This function detects ground faults between the Inverter output and the motor.

- **Load Short-circuit Detection (Fault Display: SC)**

Prior to an Inverter output, this function detects whether the output is short-circuited. If short-circuiting occurs during an output, it detects an overcurrent (oC).

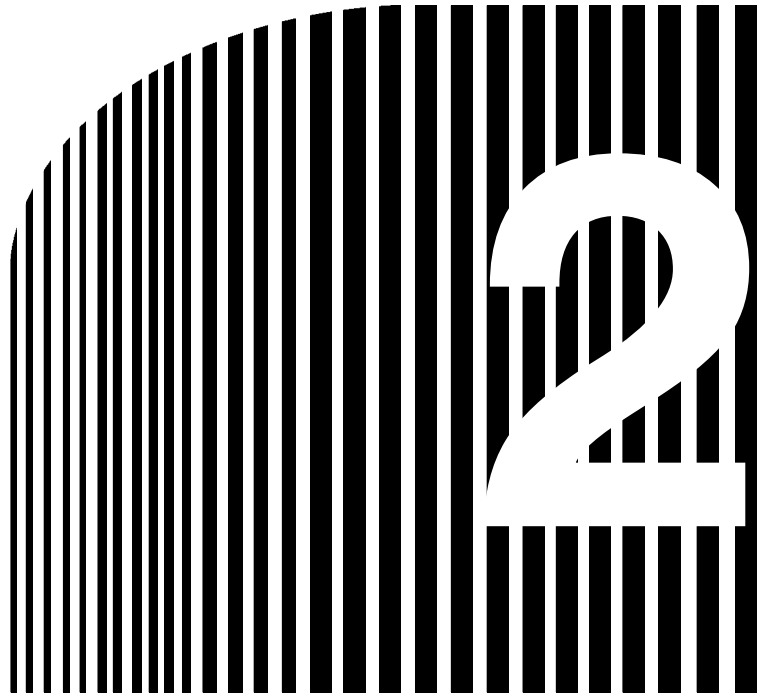

Chapter 2

• Design •

2-1 Installation

2-2 Wiring

2-1 Installation

2-1-1 Dimensions

- 3G3MV-A2001 to 3G3MV-A2007 (0.1 to 0.75 kW) 3-phase 200-VAC Input
- 3G3MV-AB001 to 3G3MV-AB004 (0.1 to 0.4 kW) Single-phase 200-VAC Input

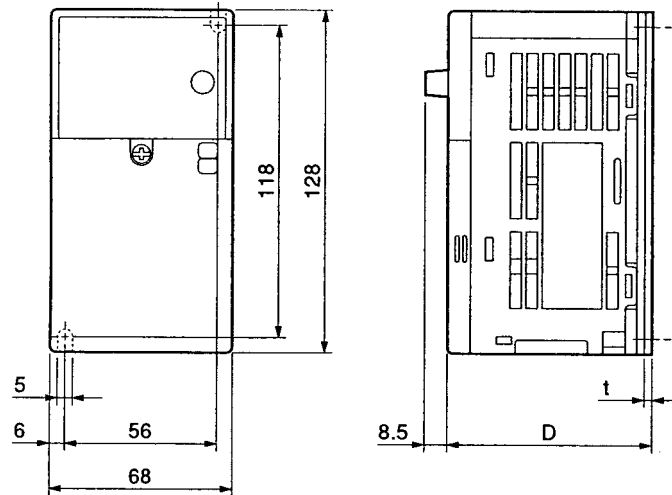

Rated voltage	Model 3G3MV-	Dimensions (mm)		Weight (kg)
		D	t	
3-phase 200 VAC	A2001	76	3	Approx. 0.6
	A2002	76	3	Approx. 0.6
	A2004	108	5	Approx. 0.9
	A2007	128	5	Approx. 1.1
Single-phase 200 VAC	AB001	76	3	Approx. 0.6
	AB002	76	3	Approx. 0.7
	AB004	131	5	Approx. 1.0

- 3G3MV-A2015 to 3G3MV-A2022 (1.5 to 2.2 kW) 3-phase 200-VAC Input
- 3G3MV-AB007 to 3G3MV-AB015 (0.75 to 1.5 kW) Single-phase 200-VAC Input
- 3G3MV-A4002 to 3G3MV-A4022 (0.2 to 2.2 kW) 3-phase 400-VAC Input

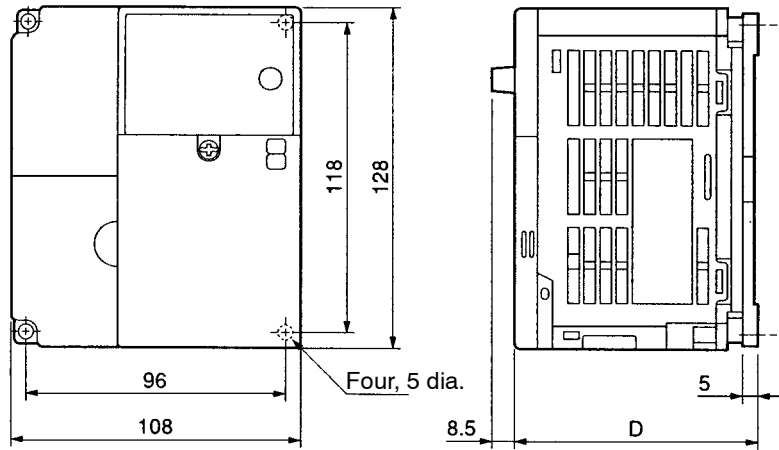

Rated voltage	Model 3G3MV-	Dimensions (mm)	Weight (kg)
		D	
3-phase 200 VAC	A2015	131	Approx. 1.4
	A2022	140	Approx. 1.5
Single-phase 200 VAC	AB007	140	Approx. 1.5
	AB015	156	Approx. 1.5
3-phase 400 VAC	A4002	92	Approx. 1.0
	A4004	110	Approx. 1.1
	A4007	140	Approx. 1.5
	A4015	156	Approx. 1.5
	A4022	156	Approx. 1.5

- 3G3MV-A2040 (4.0 kW) 3-phase 200-VAC Input
 3G3MV-AB022 (2.2 kW) Single-phase 200-VAC Input
 3G3MV-A4030 to 3G3MV-A4040 (3.0 to 4.0 kW) 3-phase 400-VAC Input

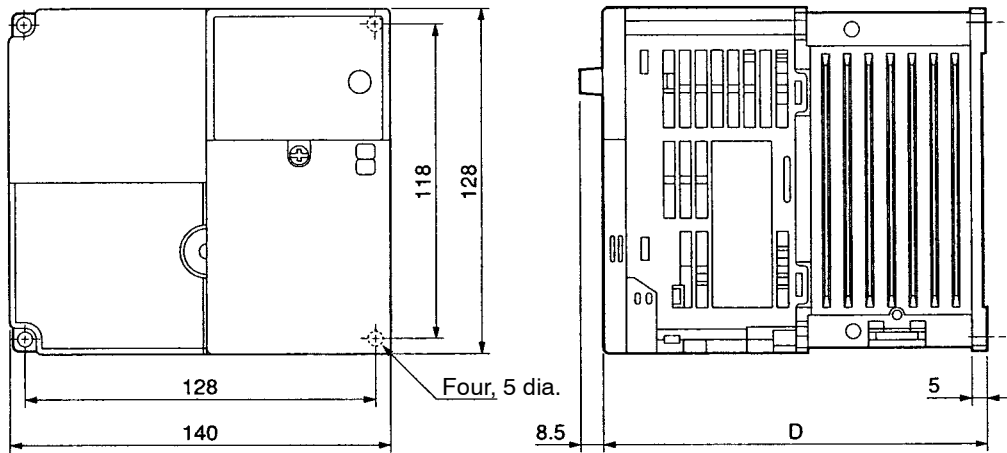

Rated voltage	Model 3G3MV-	Dimensions (mm)	Weight (kg)
		D	
3-phase 200 VAC	A2040	143	Approx. 2.1
Single-phase 200 VAC	AB022	163	Approx. 2.2
3-phase 400 VAC	A4030	143	Approx. 2.1
3-phase 400 VAC	A4040	143	Approx. 2.1

- 3G3MV-AB040 (4.0 kW) Single-phase 200-VAC Input

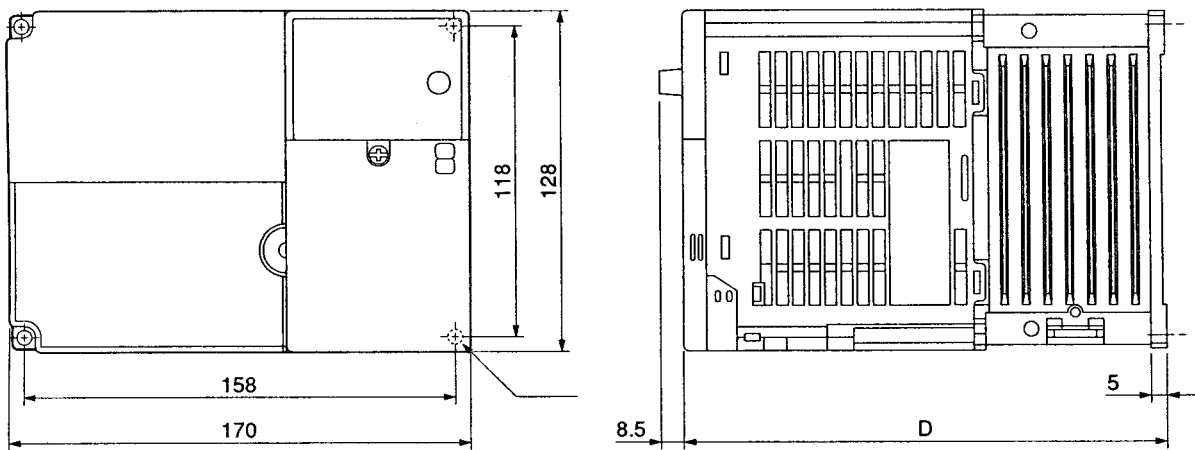



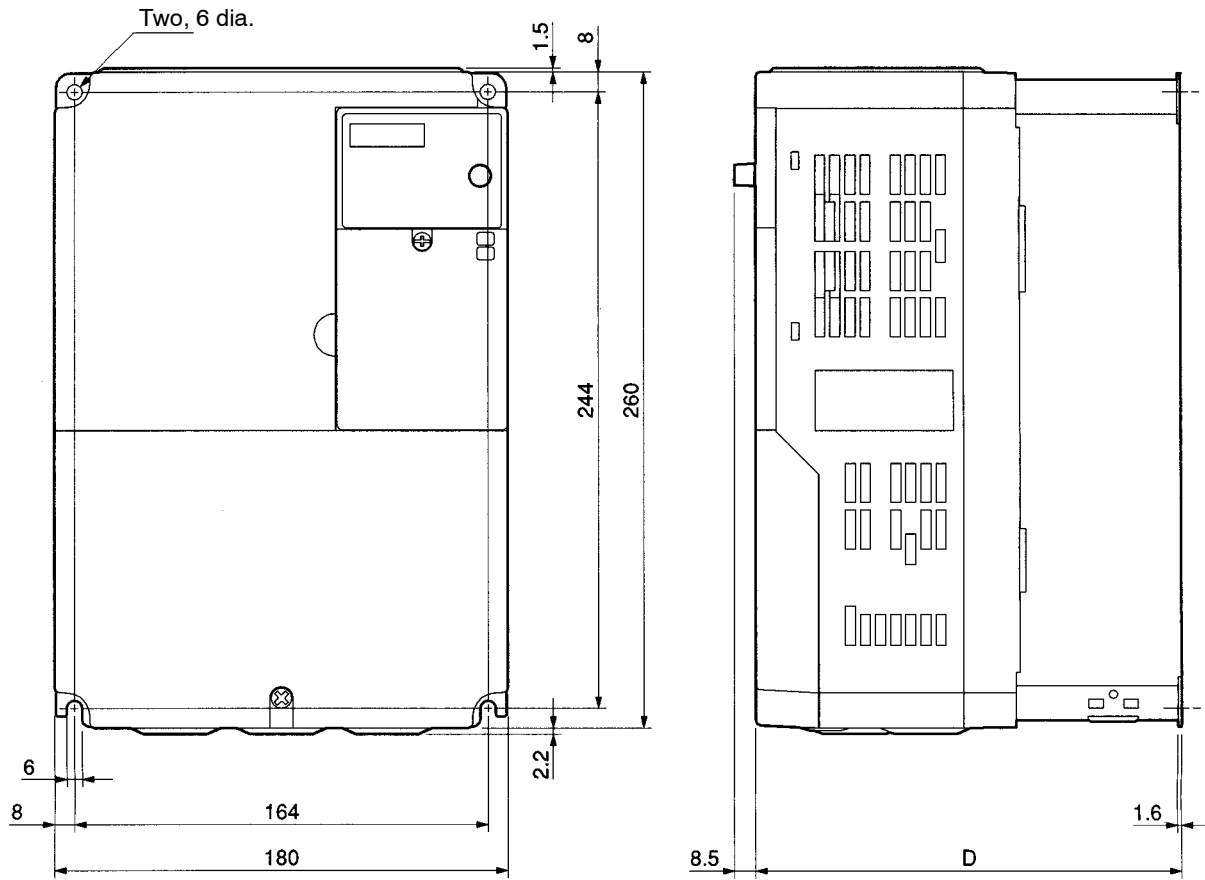

Rated voltage	Model 3G3MV-	Dimensions (mm)	Weight (kg)
		D	
Single-phase 200 VAC	AB040	180	Approx. 2.9

- 3G3MV-A2055 to 3G3MV-A2075 (5.5 to 7.5kW) 3-phase 200-VAC Input
- 3G3MV-A4055 to 3G3MV-A4075 (5.5 to 7.5kW) 3-phase 400-VAC Input



Rated voltage	Model 3G3MV-	Dimensions D (mm)	Weight (kg)
3-phase 200 VAC	A2055	170	Approx. 4.6
3-phase 200 VAC	A2075	170	Approx. 4.8
3-phase 400 VAC	A4055	170	Approx. 4.8
3-phase 400 VAC	A4075	170	Approx. 4.8

2-1-2 Installation Conditions

-  **WARNING** Provide an appropriate stopping device on the machine side to secure safety. (A holding brake is not a stopping device for securing safety.) Not doing so may result in injury.
-  **WARNING** Provide an external emergency stopping device that allows an instantaneous stop of operation and power interruption. Not doing so may result in injury.
-  **Caution** Be sure to install the product in the correct direction and provide specified clearances between the Inverter and control panel or with other devices. Not doing so may result in fire or malfunction. See explanation below.
-  **Caution** Do not allow foreign objects to enter inside the product. Doing so may result in fire or malfunction.
-  **Caution** Do not apply any strong impact. Doing so may result in damage to the product or malfunction.

■ Installation Direction and Dimensions

- Install the Inverter under the following conditions.

Ambient operating temperature:

Panel-mounting models (conforming to IP20): -10 to 50°C (0.1- to 4.0-kW Inverters)

Closed wall-mounting models (conforming to NEMA1 and IP20):
-10 to 40°C (5.5- to 7.5-kW Inverters)

Humidity: 95% max. (with no condensation)

- Note** 1. By removing the top and bottom covers from a 5.5- to 7.5-kW Inverter, it can be used as a panel-mounting model (conforming to IP00) within an ambient temperature range of -10 to 50°C.
- Install the Inverter in a clean location free from oil mist and dust. Alternatively, install it in a totally enclosed panel that is completely protected from floating dust.
 - When installing or operating the Inverter, always take special care so that metal powder, oil, water, or other foreign matter does not get into the Inverter.
 - Do not install the Inverter on inflammable material such as wood.
 - If a 5.5kW or 7.5kW Inverter is to be installed inside of a control panel, it must have the top and bottom covers removed and be used as a panel-mounting model (conforming to IP00).

■ Direction

- Install the Inverter on a vertical surface so that the characters on the nameplate are oriented upward.

■ Dimensions

- When installing the Inverter, always provide the following clearances to allow normal heat dissipation from the Inverter.

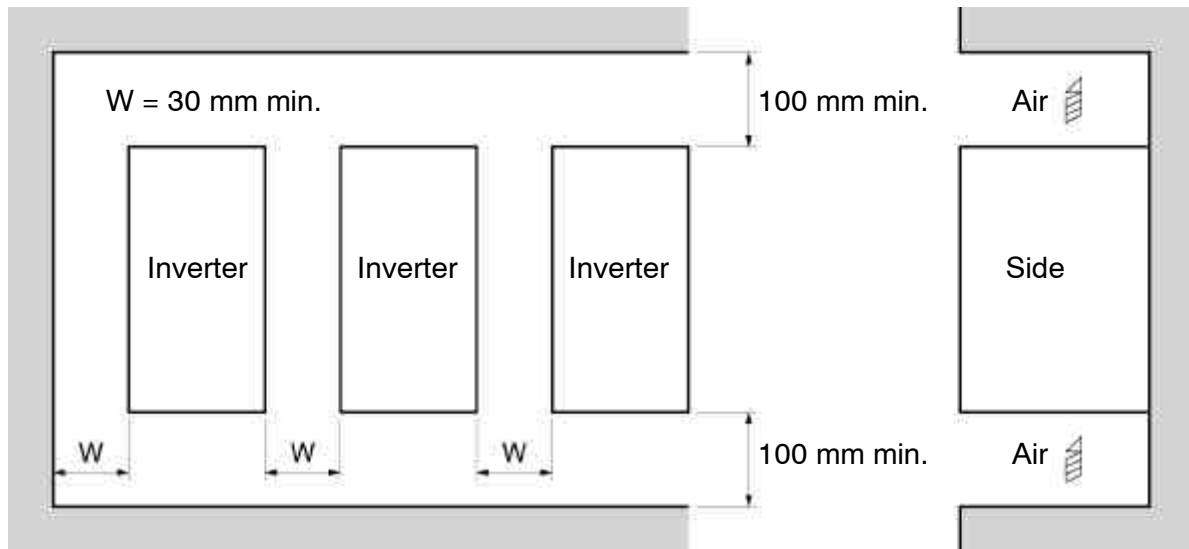

■ Ambient Temperature Control

- To enhance operation reliability, the Inverter should be installed in an environment free from extreme temperature changes.
- If the Inverter is installed in an enclosed environment such as a box, use a cooling fan or air conditioner to maintain the internal air temperature below 50°C . The life of the built-in electrolytic capacitors of the Inverter is prolonged by maintaining the internal air temperature as low as possible.
- The surface temperature of the Inverter may rise approximately 30°C higher than the ambient temperature. Be sure to keep away equipment and wires from the Inverter as far as possible if the equipment and wires are easily influenced by heat.

■ Protecting Inverter from Foreign Matter during Installation

- Place a cover over the Inverter during installation to shield it from metal power produced by drilling. Upon completion of installation, always remove the cover from the Inverter. Otherwise, ventilation will be affected, causing the Inverter to overheat.

2-1-3 Removing and Mounting the Covers

To mount the Inverter, it is necessary to remove the front cover, terminal cover (unless the Inverter is a 200-V model), and the Digital Operator. To wire the Inverter, it is necessary to remove the front cover, terminal cover (unless the Inverter is a 200-V model), and bottom cover from the Inverter. Follow the instructions below to remove the covers from the Inverter. To mount the covers, take the opposite steps.

■ Removing the Front Cover

- Loosen the front cover mounting screws with a screwdriver.
- Press the left and right sides of the front cover in the arrow 1 directions and lift the bottom of the cover in the arrow 2 direction to remove the front cover as shown in the following illustration.

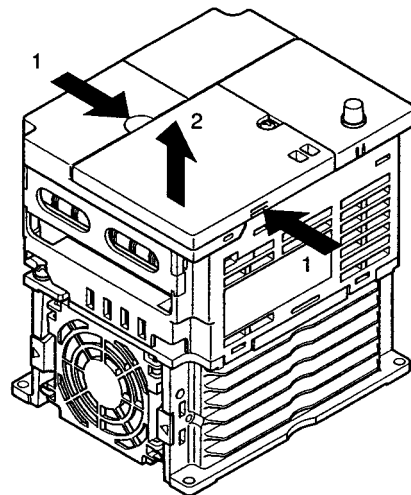

■ Removing the Terminal Cover

● 0.2- to 3.7-kW Inverters

- After the front cover is removed, press the left and right sides of the terminal cover in the arrow 1 directions and lift the terminal cover in the arrow 2 direction as shown in the following illustration.

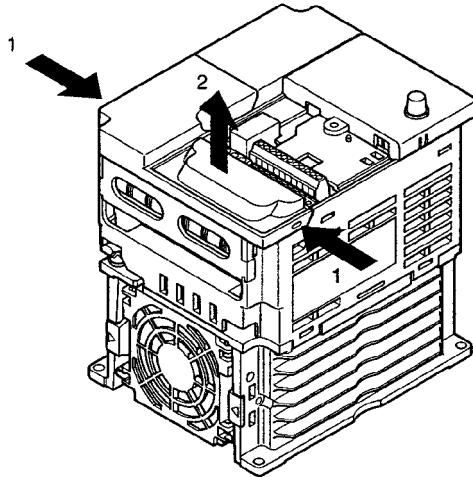

● 5.5-/7.5-kW Inverters

- Loosen the terminal cover screws in the direction of arrows 1.
- Press the left and right sides of the terminal cover in the direction of arrows 2 and lift it in the direction of arrow 3 as shown in the following illustration.

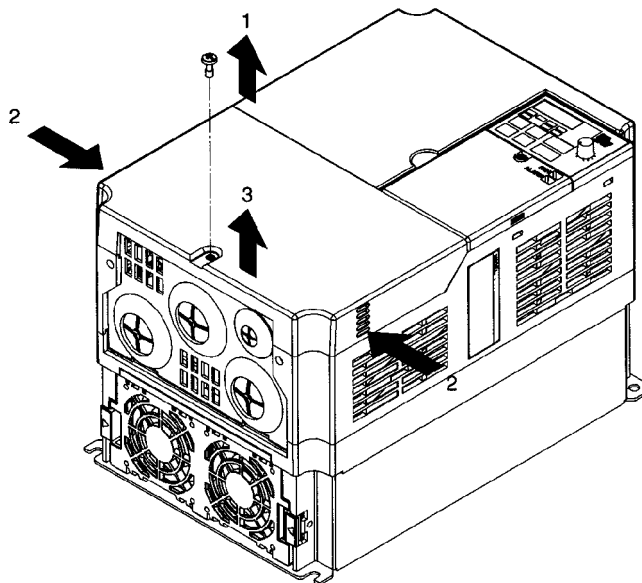

Note None of the following 200-V models have a terminal cover. Instead, the front cover is used as a terminal cover.

3G3MV-A2001 (0.1 kW), 3G3MV-A2002 (0.2 kW), 3G3MV-A2004 (0.4 kW),
3G3MV-A2007 (0.75 kW), 3G3MV-AB001 (0.1 kW), 3G3MV-AB002 (0.2 kW),
and 3G3MV-AB004 (0.4 kW)

■ Removing the Bottom Cover

- After removing the front cover and terminal cover, press the bottom cover in the arrow 1 direction based on position A as a fulcrum.

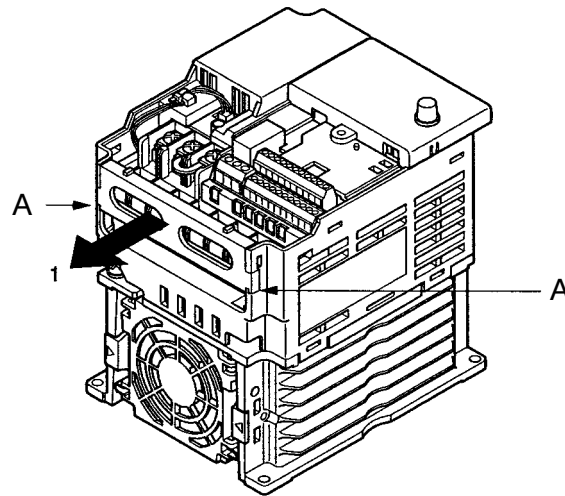





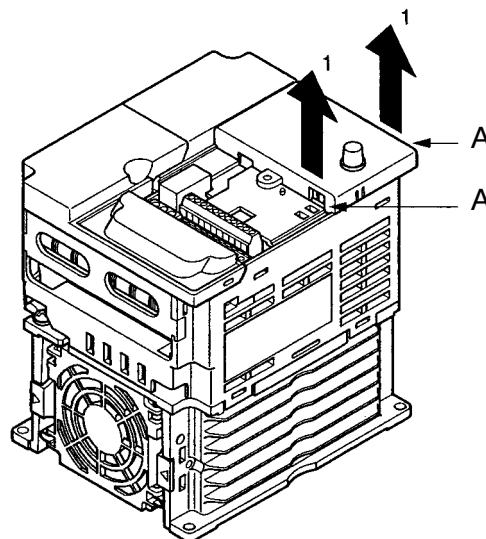





■ Removing the Digital Operator

- After removing the front cover, lift up the upper and lower right-hand sides (positions A) of the Digital Operator in the arrow 1 direction as shown in the following illustration.



2-2 Wiring

-  **WARNING** Wiring must be performed only after confirming that the power supply has been turned OFF. Not doing so may result in electrical shock.
-  **WARNING** Wiring must be performed by authorized personnel. Not doing so may result in electrical shock or fire.
-  **WARNING** Be sure to confirm operation only after wiring the emergency stop circuit. Not doing so may result in injury.
-  **WARNING** Always connect the ground terminals to a ground of 100 Ω or less for the 200-VAC class, or 10 Ω or less for the 400-VAC class. Not connecting to a proper ground may result in electrical shock.
-  **Caution** Install external breakers and take other safety measures against short-circuiting in external wiring. Not doing so may result in fire.
-  **Caution** Confirm that the rated input voltage of the Inverter is the same as the AC power supply voltage. An incorrect power supply may result in fire, injury, or malfunction.
-  **Caution** If you use a Braking Resistor or a Braking Resistor Unit, connect them as specified in the manual. Not doing so may result in fire.
-  **Caution** Be sure to wire correctly and securely. Not doing so may result in injury or damage to the product.
-  **Caution** Be sure to firmly tighten the screws on the terminal block. Not doing so may result in fire, injury, or damage to the product.
-  **Caution** Do not connect an AC power to the U, V, or W output. Doing so may result in damage to the product or malfunction.

2-2-1 Terminal Block

To wire the terminal block of the Inverter, remove the front cover, terminal cover (unless the Inverter is a 200-V model), and bottom cover from the Inverter.

There is a label under the front cover indicating the arrangement of main circuit terminals. Be sure to remove the label after wiring the terminals. The output terminal of the motor has a label as well. Remove the label before wiring the motor terminal.

■ Arrangement of Control Circuit Terminals

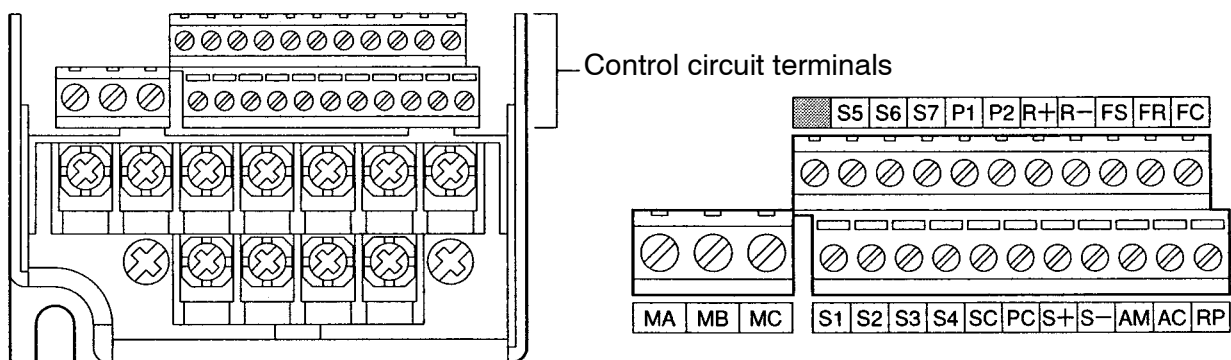

■ Arrangement of Main Circuit Terminals

- 3G3MV-A2001 through 3G3MV-A2007 (0.1 through 0.75 kW):
3-phase 200-VAC Input
- 3G3MV-AB001 through 3G3MV-AB004 (0.1 through 0.4 kW):
Single-phase 200-VAC Input

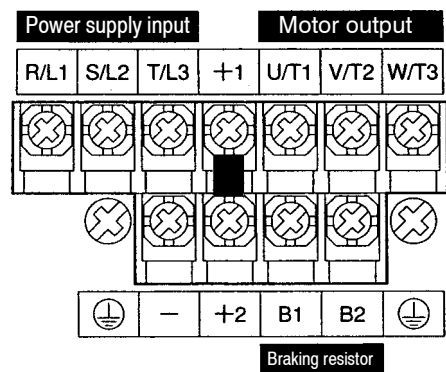

Note For single-phase input, connect R/L1 and S/L2.

- 3G3MV-A2015 to 3G3MV-A2022 (1.5 to 2.2 kW): 3-phase 200-VAC Input
 3G3MV-AB007 to 3G3MV-AB015 (0.75 to 1.5 kW):
 Single-phase 200-VAC Input
- 3G3MV-A4002 to 3G3MV-A4022 (0.2 to 2.2 kW): 3-phase 400-VAC Input

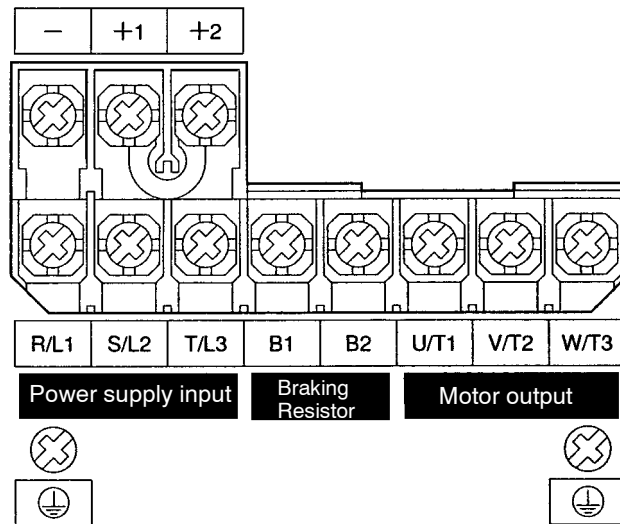

Note For single-phase input, connect R/L1 and S/L2.

- 3G3MV-A2040 (4.0 kW) to -A2075 (4.0 to 7.5kW): 3-phase 200-VAC Input
 3G3MV-AB022 to 3G3MV-AB040 (2.2 to 4.0 kW):
 Single-phase 200-VAC Input
- 3G3MV-A4030 to 3G3MV-A4075 (3.0 to 7.5 kW): 3-phase 400-VAC Input

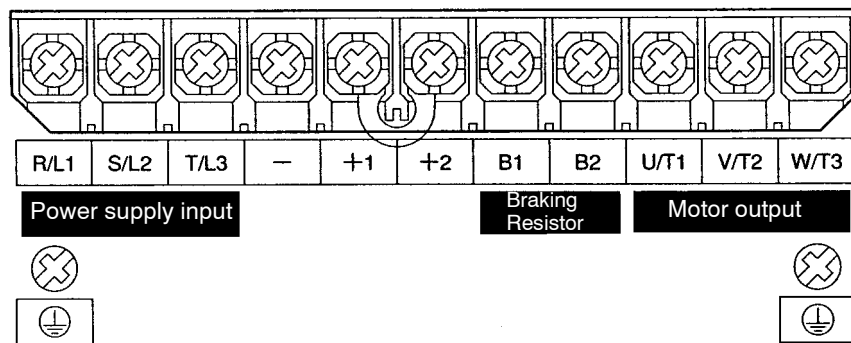

Note For single-phase input, connect R/L1 and S/L2.

■ Main Circuit Terminals

Symbol	Name	Description
R/L1	Power supply input terminals	3G3MV-A2□: 3-phase 200 to 230 VAC
S/L2		3G3MV-AB□: Single-phase 200 to 240 VAC (see note 1)
T/L3		3G3MV-A4□: 3-phase 380 to 460 VAC
U/T1	Motor output terminals	3-phase power supply output for driving motors. (see note 2)
V/T2		3G3MV-A2□ and 3G3MV-AB□: 3-phase 200 to 230 VAC
W/T3		3G3MV-A4□: 3-phase 380 to 460 VAC
B1	Braking Resistor connection terminals	Terminals for attaching an external Braking Resistor or a Braking Resistor Unit. (Connect to detect overvoltage during braking.)
B2		
+1	Connection terminals +1 and +2: DC reactor connection terminals +1 and -: DC power supply input terminals	Connect the DC reactor for suppressing harmonics to terminals +1 and +2.
+2		When driving the Inverter with DC power, input the DC power to terminals +1 and -.
-		(Terminal +1 is a positive terminal.)
	Ground terminal	Be sure to ground the terminal under the following conditions. 3G3MV-A2□: Ground at a resistance of 100 Ω or less. 3G3MV-AB□: Ground at a resistance of 100 Ω or less. 3G3MV-A4□: Ground at a resistance of 10 Ω or less. To conform to EC Directives, connect to the neutral point of the power supply. Note Be sure to connect the ground terminal directly to the motor frame ground.

Note 1. Connect single-phase input to both the R/L1 terminal and the S/L2 terminal.

Note 2. The maximum voltage at the output side corresponds to the power supply voltage for Inverter input.

■ Control Circuit Terminals

Symbol		Name	Specification	
Input	S1	Multi-function input 1 (Forward/Stop)	Photocoupler 8 mA at 24 V DC (See notes 2 and 3.)	
	S2	Multi-function input 2 (Reverse/Stop)		
	S3	Multi-function input 3 (External fault: Normally open)		
	S4	Multi-function input 4 (Fault reset)		
	S5	Multi-function input 5 (Multi-step speed reference 1)		
	S6	Multi-function input 6 (Multi-step speed reference 2)		
	S7	Multi-function input 7 (Inching frequency command)		
	SC	Sequence input common		
	FS	Frequency reference power supply output		20 mA at 12 V DC
	FR	Frequency reference input		0 to 10 V DC (Input impedance: 20 kΩ)
FC	Frequency reference common			
	RP	Pulse train input	Response frequency: 0 to 33 kHz (30% to 70% ED)* H: 3.5 to 13.2 V L: 0.8 V max. (Input impedance: 2.24 kΩ)	
CN2	1	Multi-function analog voltage input	Voltage input (between terminals 1 and 3): 0 to 10 V DC (Input impedance: 20 kΩ) Current input (between terminals 2 and 3): 4 to 20 mA (Input impedance: 250 Ω). This connector is located in the Unit Operator of the Inverter.	
	2	Multi-function analog current input		
	3	Multi-function analog input common		

* ED = Operating Duty Cycle.

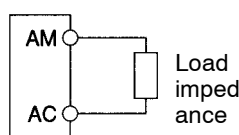
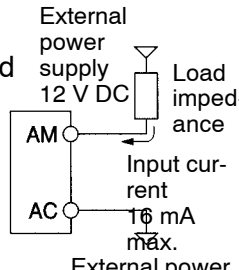
Symbol		Name	Specification					
Output	MA	Multi-function contact output (Normally open: During operation)	Relay output 1 A max. at 30 V DC 1 A max. at 250 V AC					
	MB	Multi-function contact output (Normally closed: During operation)						
	MC	Multi-function contact output common						
	P1	Multi-function photo-coupler output 1 (Fault)	Open collector output 50 mA max. at 48 V DC					
	P2	Multi-function photo-coupler output 2 (Fault)						
	PC	Multi-function photo-coupler output common						
	AM	Multi-function analog output	<ul style="list-style-type: none"> Analog output: 2 mA max. at 0 to 10 V DC Pulse train output (max. output voltage: 12 V DC) (See note 4.) <p>When Used as Voltage Output</p> <table border="1"> <thead> <tr> <th>Output voltage (insulation type)</th> <th>Load impedance</th> </tr> </thead> <tbody> <tr> <td>+5 V</td> <td>1.5 kΩ min.</td> </tr> <tr> <td>+10 V</td> <td>10 kΩ min.</td> </tr> </tbody> </table> 	Output voltage (insulation type)	Load impedance	+5 V	1.5 kΩ min.	+10 V
Output voltage (insulation type)	Load impedance							
+5 V	1.5 kΩ min.							
+10 V	10 kΩ min.							
AC	Multi-function analog output common	<p>When External Power Supply is Used</p> <table border="1"> <thead> <tr> <th>External power supply (V)</th> <th>Input current (mA) from external power supply</th> </tr> </thead> <tbody> <tr> <td>12 V DC (±5%)</td> <td>16 mA max.</td> </tr> </tbody> </table>  <p>Note Do not use a 5-V DC or 24-V DC external power supply. Doing so can cause internal circuit damage or malfunctioning.</p>	External power supply (V)	Input current (mA) from external power supply	12 V DC (±5%)	16 mA max.		
External power supply (V)	Input current (mA) from external power supply							
12 V DC (±5%)	16 mA max.							
Com- mu- nica- tions	R+	Receiver side	Conforming to RS-422/485					
	R-							
	S+	Sender side						
	S-							

- Note 1.** Parameter settings can be used to select various functions for multi-function inputs 1 to 7, multi-function contact outputs, and multi-function photocoupler outputs. The functions in parentheses are the default settings.
- Note 2.** NPN is the default setting for these terminals. Wire them by providing a common ground. No external power supply is required.
- Note 3.** To provide an external power supply and wire the terminals through a common positive line, set SW1 to PNP and use a 24 V DC $\pm 10\%$ external power supply.
- Note 4.** When multi-function analog outputs are used for pulse train outputs, they can be directly connected to the pulse train inputs at other 3G3MV-series Inverters for simple synchronization or other applications.

■ **Selecting Input Method**

- Switches SW1 and SW2, both of which are located above the control circuit terminals, are used for input method selection.
Remove the front cover and optional cover to use these switches.

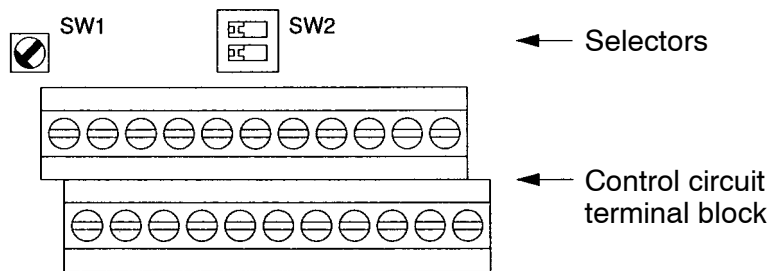

● **Selecting Sequence Input Method**

• By using SW1, NPN or PNP input can be selected as shown below.

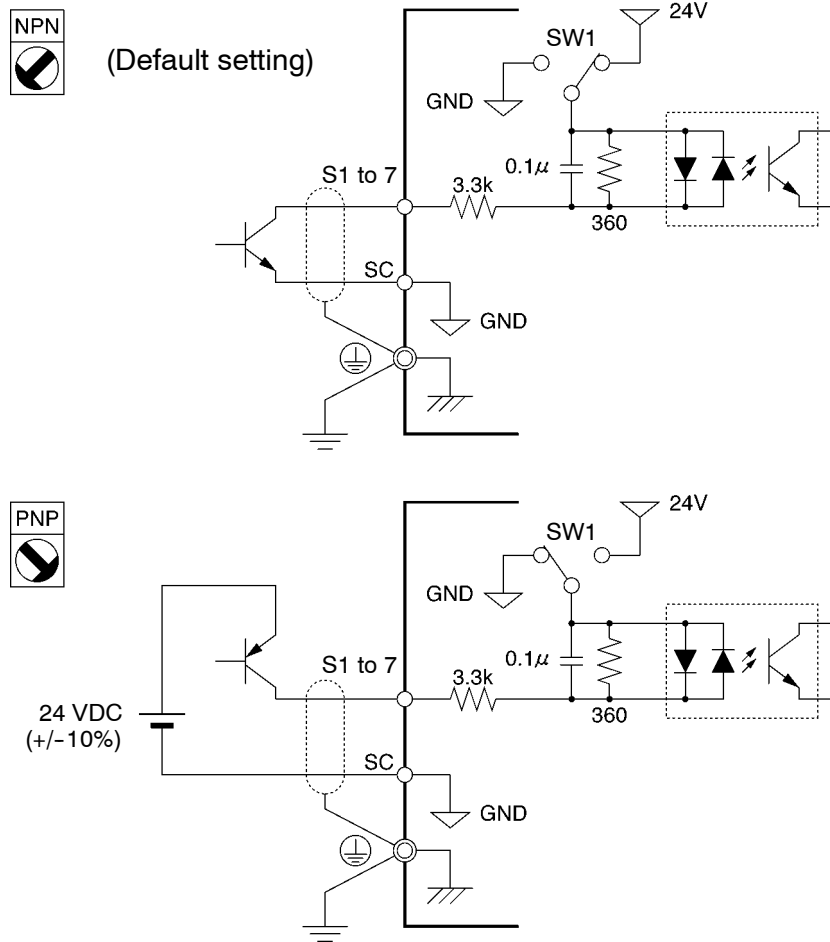

● **Selecting RS-422/485 Termination Resistance**

• Termination resistance can be selected by setting pin 1 of the SW2 to ON. The default setting for the pin is OFF.

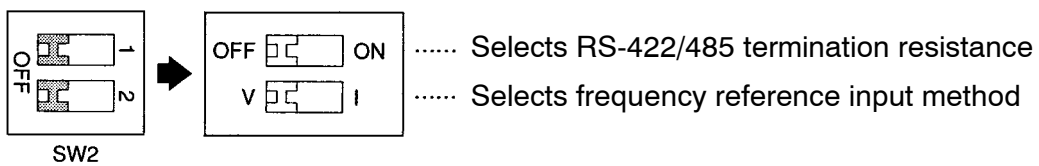

Communications method	Pin 1 setting
RS-422	Set to ON
RS-485	Set to ON only if the Unit is the end Slave.

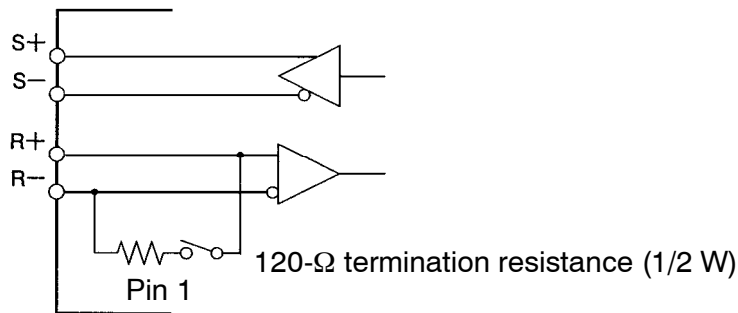

● **Selecting Frequency Reference Input Method**

- By using pin 2 of SW2, voltage input or current input can be selected as the input method for frequency reference. The default setting is for voltage input. Parameter settings are required together with the selection of the frequency reference input method.

Frequency reference input method	Pin 2 setting	Frequency reference selection (parameter n004)
Voltage input (default setting)	V (OFF)	Set value 2
Current input	I (ON)	Set value 3 or 4

Note Do not set pin 2 to ON for current input while voltage input is ON, otherwise the resistor in the input circuit may burn out.

2-2-2 Standard Connections

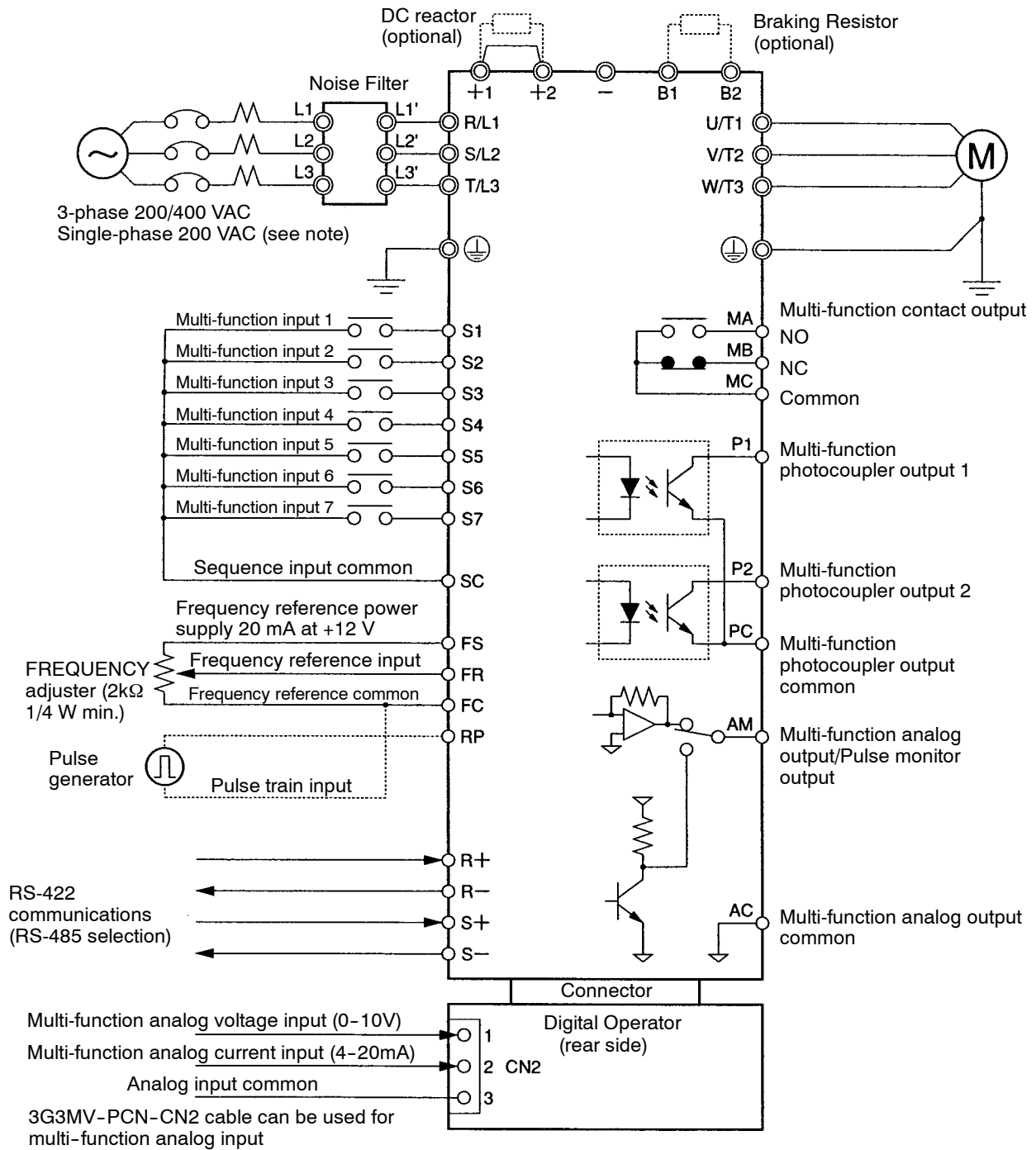

Note Connect single-phase 200 VAC to terminals R/L1 and S/L2 of the 3G3MV-AB□.

● Example of 3-wire Sequence Connections

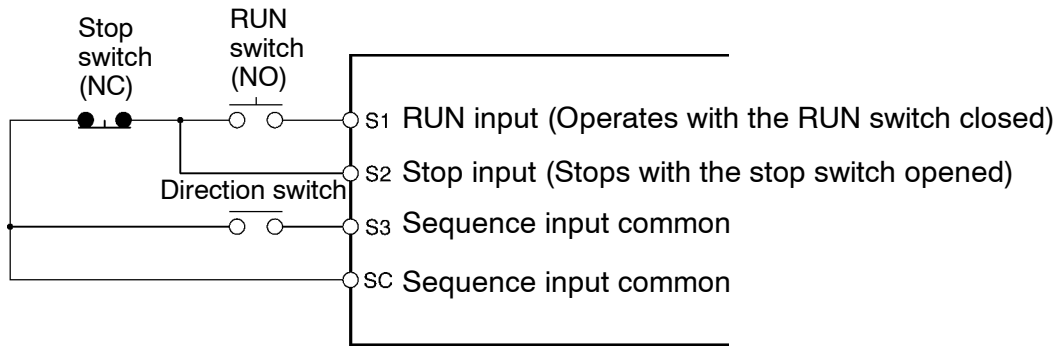

Note Set parameter 052 to forward/reverse rotation command 0 for 3-wire sequence input.







2-2-3 Wiring around the Main Circuit

■ Wire Size, Terminal Screw, Screw Tightening Torque, and Molded-case Circuit Breaker Capacities

- For the main circuit and ground, always use 600-V polyvinyl chloride (PVC) cables.
- If any cable is long and may cause voltage drops, increase the wire size according to the cable length.







● 3-phase 200-VAC Model

Model 3G3MV-	Terminal symbol	Terminal screw	Screw tightening torque (N•m)	Wire size (mm ²)	Recommended wire size (mm ²)	Molded-case circuit breaker capacity (A)
A2001	R/L1, S/L2, T/L3, B1, B2, -, +1, +2, U/T1, V/T2, W/T3 ⊥	M3.5	0.8 to 1.0	0.75 to 2	2	5
A2002	R/L1, S/L2, T/L3, B1, B2, -, +1, +2, U/T1, V/T2, W/T3 ⊥	M3.5	0.8 to 1.0	0.75 to 2	2	5
A2004	R/L1, S/L2, T/L3, B1, B2, -, +1, +2, U/T1, V/T2, W/T3 ⊥	M3.5	0.8 to 1.0	0.75 to 2	2	5

Model 3G3MV-	Terminal symbol	Terminal screw	Screw tightening torque (N•m)	Wire size (mm ²)	Recommended wire size (mm ²)	Molded-case circuit breaker capacity (A)
A2007	R/L1, S/L2, T/L3, B1, B2, -, +1, +2, U/T1, V/T2, W/T3	M3.5	0.8 to 1.0	0.75 to 2	2	10
						
A2015	R/L1, S/L2, T/L3, B1, B2, -, +1, +2, U/T1, V/T2, W/T3	M4	1.2 to 1.5	2 to 5.5	2	20
					3.5	
A2022	R/L1, S/L2, T/L3, B1, B2, -, +1, +2, U/T1, V/T2, W/T3	M4	1.2 to 1.5	2 to 5.5	3.5	20
						
A2040	R/L1, S/L2, T/L3, B1, B2, -, +1, +2, U/T1, V/T2, W/T3	M4	1.2 to 1.5	2 to 5.5	5.5	30
						
A2055	R/L1, S/L2, T/L3, B1, B2, -, +1, +2, U/T1, V/T2, W/T3	M5	2.5	5.5 to 8	8	50
						
A2075	R/L1, S/L2, T/L3, B1, B2, -, +1, +2, U/T1, V/T2, W/T3	M5	2.5	5.5 to 8	8	60
						









● Single-phase 200-VAC Model

Model 3G3MV-	Terminal symbol	Terminal screw	Terminal torque (N•m)	Wire size (mm ²)	Recommended wire size (mm ²)	Circuit breaker capacity (A)
AB001	R/L1, S/L2, T/L3, B1, B2, -, +1, +2, U/T1, V/T2, W/T3	M3.5	0.8 to 1.0	0.75 to 2	2	5
						

Model 3G3MV-	Terminal symbol	Terminal screw	Terminal torque (N•m)	Wire size (mm ²)	Recommended wire size (mm ²)	Circuit breaker capacity (A)
AB002	R/L1, S/L2, T/L3, B1, B2, -, +1, +2, U/T1, V/T2, W/T3	M3.5	0.8 to 1.0	0.75 to 2	2	5
						
AB004	R/L1, S/L2, T/L3, B1, B2, -, +1, +2, U/T1, V/T2, W/T3	M3.5	0.8 to 1.0	0.75 to 2	2	10
						
AB007	R/L1, S/L2, T/L3, B1, B2, -, +1, +2, U/T1, V/T2, W/T3	M4	1.2 to 1.5	2 to 5.5	3.5	20
					2	
AB015	R/L1, S/L2, T/L3, B1, B2, -, +1, +2, U/T1, V/T2, W/T3	M4	1.2 to 1.5	2 to 5.5	5.5	20
					3.5	
AB022	R/L1, S/L2, T/L3, B1, B2, -, +1, +2, U/T1, V/T2, W/T3	M4	1.2 to 1.5	2 to 5.5	5.5	40
						
AB040	R/L1, S/L2, T/L3, B1, B2, -, +1, +2, U/T1, V/T2, W/T3	M5	2.3 to 2.4	5.5 to 8	8	50
		M4	1.2 to 1.5	2 to 8	5.5	

● 3-phase 400-VAC Model

Model 3G3MV-	Terminal symbol	Terminal screw	Screw tightening torque (N•m)	Wire size (mm ²)	Recommended wire size (mm ²)	Molded-case circuit breaker capacity (A)
A4002	R/L1, S/L2, T/L3, B1, B2, -, +1, +2, U/T1, V/T2, W/T3	M4	1.2 to 1.5	2 to 5.5	2	5
						

Model 3G3MV-	Terminal symbol	Terminal screw	Screw tighten- ing torque (N•m)	Wire size (mm ²)	Recom- mended wire size (mm ²)	Molded- case circuit breaker capac- ity (A)
A4004	R/L1, S/L2, T/L3, B1, B2, -, +1, +2, U/T1, V/T2, W/T3	M4	1.2 to 1.5	2 to 5.5	2	5
						
A4007	R/L1, S/L2, T/L3, B1, B2, -, +1, +2, U/T1, V/T2, W/T3	M4	1.2 to 1.5	2 to 5.5	2	5
						
A4015	R/L1, S/L2, T/L3, B1, B2, -, +1, +2, U/T1, V/T2, W/T3	M4	1.2 to 1.5	2 to 5.5	2	10
						
A4022	R/L1, S/L2, T/L3, B1, B2, -, +1, +2, U/T1, V/T2, W/T3	M4	1.2 to 1.5	2 to 5.5	2	10
						
A4030	R/L1, S/L2, T/L3, B1, B2, -, +1, +2, U/T1, V/T2, W/T3	M4	1.2 to 1.5	2 to 5.5	2	20
					3.5	
A4040	R/L1, S/L2, T/L3, B1, B2, -, +1, +2, U/T1, V/T2, W/T3	M4	1.2 to 1.5	2 to 5.5	2	20
					3.5	
A4055	R/L1, S/L2, T/L3, B1, B2, -, +1, +2, U/T1, V/T2, W/T3	M4	1.8	5.5	5.5	30
						
A4075	R/L1, S/L2, T/L3, B1, B2, -, +1, +2, U/T1, V/T2, W/T3	M5	1.8	5.5 to 8	5.5	30
						

■ Wiring on the Input Side of the Main Circuit

● Installing a Molded-case Circuit Breaker

Always connect the power input terminals (R/L1, S/L2, and T/L3) and power supply via a molded case circuit breaker (MCCB) suitable to the Inverter.

- Install one wiring circuit breaker per Inverter.
- Choose an MCCB with a capacity of 1.5 to 2 times the Inverter’s rated current.
- For the MCCB’s time characteristics, be sure to consider the Inverter’s overload protection (one minute at 150% of the rated output current).
- If the MCCB is to be used in common among multiple Inverters, or other devices, set up a sequence such that the power supply will be turned OFF by a fault output, as shown in the following diagram.

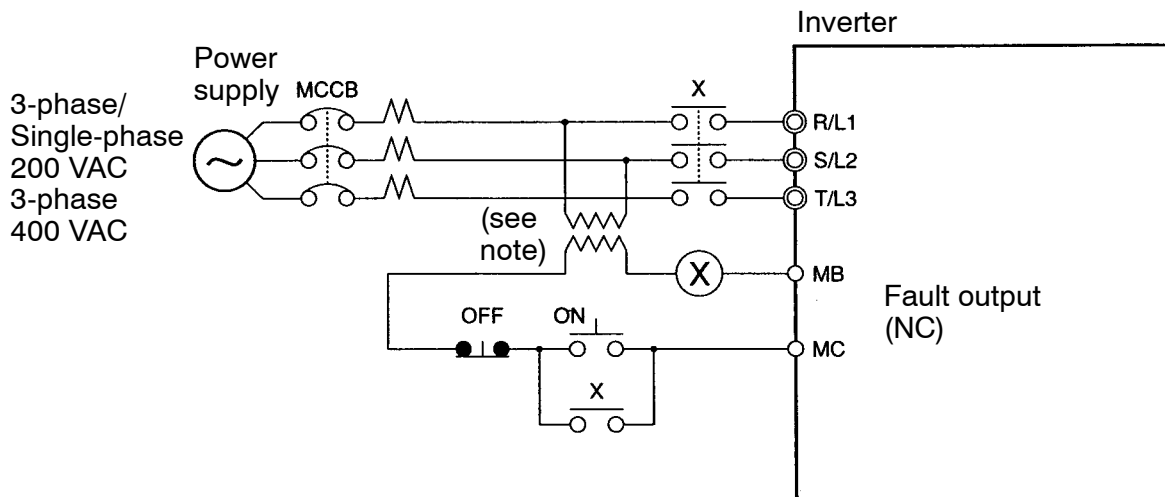

Note Use a 400/200 V transformer for a 400-V model.

● Installing a Ground Fault Interrupter

Inverter outputs use high-speed switching, so high-frequency leakage current is generated.

In general, a leakage current of approximately 100 mA will occur for each Inverter (when the power cable is 1 m) and approximately 5 mA for each additional meter of power cable.

Therefore, at the power supply input area, use a special-purpose breaker for Inverters, which detects only the leakage current in the frequency range that is hazardous to humans and excludes high-frequency leakage current.

- For the special-purpose breaker for Inverters, choose a ground fault interrupter with a sensitivity amperage of at least 10 mA per Inverter.
- When using a general leakage breaker, choose a ground fault interrupter with a sensitivity amperage of 200 mA or more per Inverter and with an operating time of 0.1 s or more.

● **Installing a Magnetic Contactor**

If the power supply of the main circuit is to be shut off because of the sequence, a magnetic contactor can be used instead of a molded-case circuit breaker.

When a magnetic contactor is installed on the primary side of the main circuit to stop a load forcibly, however, the regenerative braking does not work and the load coasts to a stop.

- A load can be started and stopped by opening and closing the magnetic contactor on the primary side. Frequently opening and closing the magnetic contactor, however, may cause the Inverter to break down.
- When the Inverter is operated with the Digital Operator, automatic operation cannot be performed after recovery from a power interruption.
- When using the Braking Resistor Unit, be sure to arrange a sequence in which the thermal relay of the Unit turns the magnetic contactor OFF.

● **Connecting Input Power Supply to the Terminal Block**

Input power supply can be connected to any terminal on the terminal block because the phase sequence of input power supply is irrelevant to the phase sequence (R/L1, S/L2, and T/L3).

● **Installing an AC Reactor**

If the Inverter is connected to a large-capacity power transformer (660 kW or more) or the external phase advance capacitor of the customer is switched, an excessive peak current may flow through the input power circuit, causing the converter unit to break down.

To prevent this, install an optional AC reactor on the input side of the Inverter.

This also improves the power factor on the power supply side.

● **Installing a Surge Absorber**

Always use a surge absorber or diode for the inductive loads near the Inverter. These inductive loads include magnetic contactors, electromagnetic relays, solenoid valves, solenoid, and magnetic brakes.

● Installing a Noise Filter on the Power Supply Side

The Inverter's outputs utilize high-speed switching, so noise may be transmitted from the Inverter to the power line and adversely affect other devices in the vicinity. It is recommended that a Noise Filter be installed at the Power Supply to minimize this noise transmission. Conversely, noise can also be reduced from the power line to the Inverter.

Wiring Example

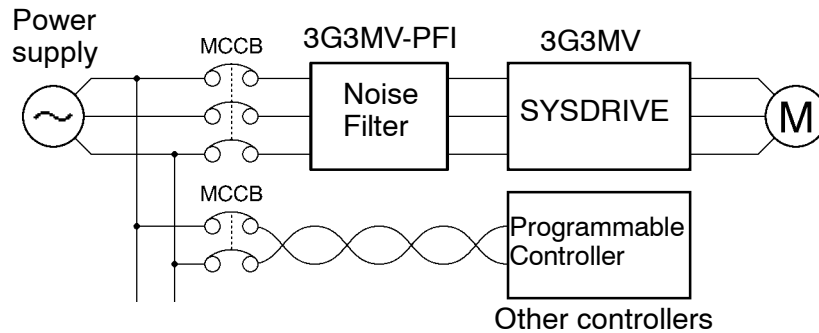

Note Use a special-purpose Noise Filter for the SYSDRIVE 3G3MV. A general purpose noise filter will be less effective and may not reduce noise. Please, use the noise filters as explained in Chapter 9-2.

■ Wiring on the Output Side of the Main Circuit

● Connecting the Terminal Block to the Load

Connect output terminals U/T1, V/T2, and W/T3 to motor lead wires U, V, and W.

Check that the motor rotates forward with the forward command. Forward means shaft of the AC motor rotates in CCW (Counter Clock Wise), if you look from shaft to motor end. Switch over any two of the output terminals to each other and reconnect if the motor rotates in reverse with the forward command.

● Never Connect a Power Supply to Output Terminals

Never connect a power supply to output terminals U/T1, V/T2, or W/T3.

If voltage is applied to the output terminals, the internal circuit of the Inverter will be damaged.

● Never Short or Ground Output Terminals

If the output terminals are touched with bare hands or the output wires come into contact with the Inverter casing, an electric shock or grounding will occur. This is extremely hazardous.

Also, be careful not to short the output wires.

● **Do not Use a Phase Advancing Capacitor or Noise Filter**

Never connect a phase advance capacitor or LC/RC Noise Filter to the output circuit. Doing so will result in damage to the Inverter or cause other parts to burn.

● **Do not Use an Electromagnetic Switch or Magnetic Contactor**

Do not connect an electromagnetic switch or magnetic contactor to the output circuit. If a load is connected to the Inverter during running, an inrush current will actuate the overcurrent protective circuit in the Inverter.

● **Installing a Thermal Relay**

The Inverter has an electronic thermal protection function to protect the motor from overheating. If, however, more than one motor is operated with one inverter or a multi-polar motor is used, always install a thermal relay (THR) between the Inverter and the motor and set n037 to 2 (no thermal protection).

In this case, program the sequence so that the magnetic contactor on the input side of the main circuit is turned OFF by the contact of the thermal relay.

● **Installing a Noise Filter on the Output Side**

Connect a Noise Filter to the output side of the Inverter to reduce radio noise and induction noise.

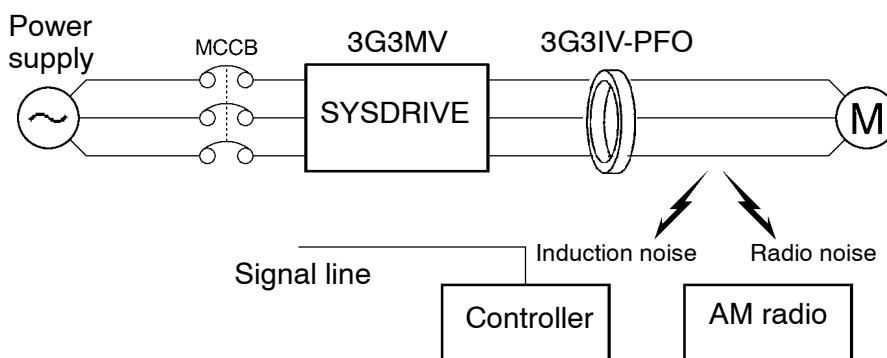

Note Please refer to page 2-41 for a detailed explanation.

Induction Noise: Electromagnetic induction generates noise on the signal line, causing the controller to malfunction.

Radio Noise: Electromagnetic waves from the Inverter and cables cause the broadcasting radio receiver to make noise.

● Countermeasures against Induction Noise

As described previously, a Noise Filter can be used to prevent induction noise from being generated on the output side. Alternatively, cables can be routed through a grounded metal pipe to prevent induction noise. Keeping the metal pipe at least 30 cm away from the signal line considerably reduces induction noise.

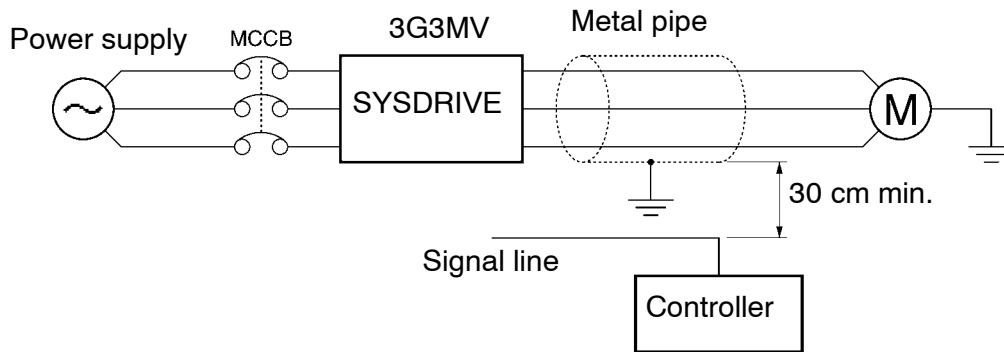

● Countermeasures against Radio Interference

Radio noise is generated from the Inverter as well as the input and output lines. To reduce radio noise, install Noise Filters on both input and output sides, and also install the Inverter in a totally enclosed steel box.

The cable between the Inverter and the motor should be as short as possible.

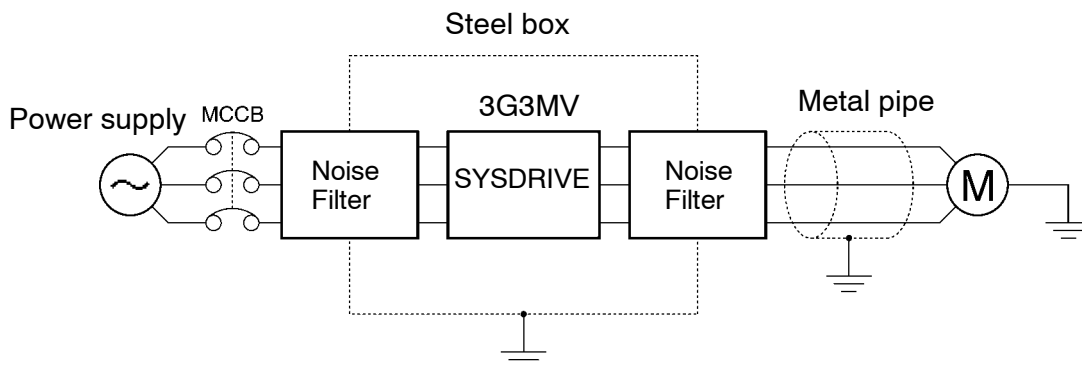

● Cable Length between Inverter and Motor

As the cable length between the Inverter and the motor is increased, the floating capacity between the Inverter outputs and the ground is increased proportionally. The increase in floating capacity at the Inverter outputs causes the high-frequency leakage current to increase, and this may adversely affect peripheral devices and the current detector in the Inverter’s output section. To prevent this from occurring, use a cable of no more than 100 meters between the Inverter and the motor. If the cable must be longer than 100 meters, take measures to reduce the floating capacity by not wiring in metallic ducts, by using a separate cable for each phase, and so on.

Also adjust the carrier frequency (set in n80) according to the cable length between the Inverter and the motor, as shown in the table below.

Cable length	50 m max.	100 m max.	More than 100 m
Carrier frequency	10 kHz max.	5 kHz max.	2.5 kHz max.

- **Single-phase motors cannot be used**

The inverter is not suited for the variable speed control of single-phase motors. Single-phase motors are either capacitor start motors or split-phase start motors (the method for determining rotation direction at startup is different). If a capacitor start motor is used, the capacitor may be damaged by a sudden electric discharge caused by inverter output. If a split-phase motor is used, the starting coil may burn because the centrifugal switch does not operate.

■ Ground Wiring

- Always use the ground terminal of the 200-V Inverter with a ground resistance of 100 Ω or less. Similarly, always use the ground terminal of the 400-V Inverter with a ground resistance of 10 Ω or less.
- Do not share the ground wire with other devices such as welding machines or power tools.
- Always use a ground wire that complies with technical standards on electrical equipment and minimize the length of the ground wire.
Leakage current flows through the Inverter. Therefore, if the distance between the ground electrode and the ground terminal is too long, the potential on the ground terminal of the Inverter will become unstable.
- When using more than one Inverter, be careful not to loop the ground wire.

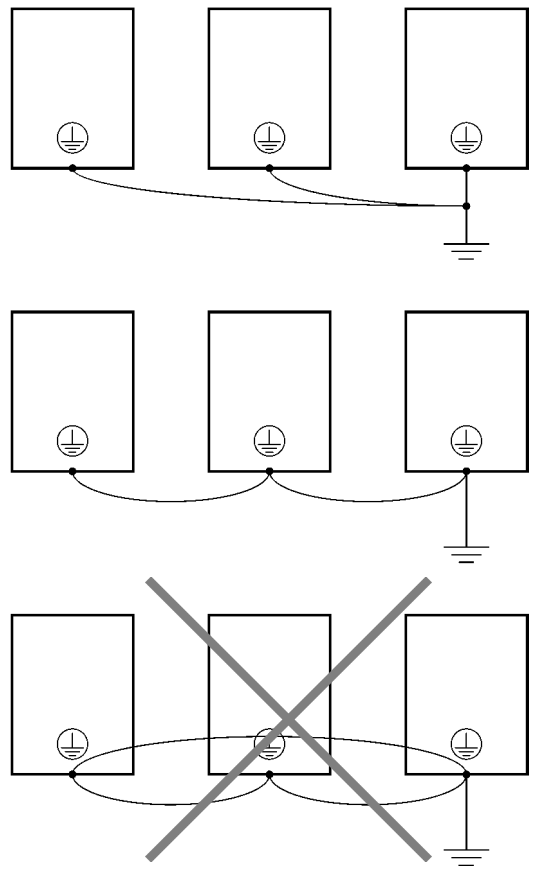

■ Harmonics

● Definition

Harmonics consist of electric power produced from AC power and alternating at frequencies that are integral multiples of the frequency of the AC power.

The following frequencies are harmonics of a 60- or 50-Hz commercial power supply.

Second harmonic: 120 (100) Hz

Third harmonic: 180 (150) Hz

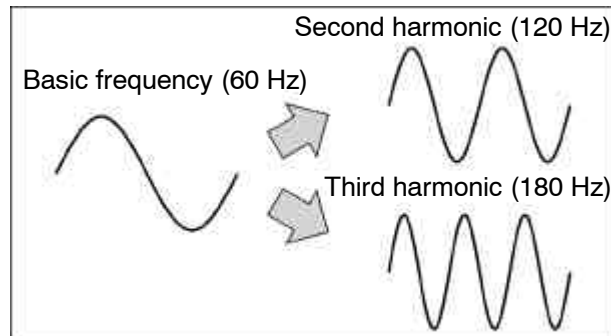

Problems Caused by Harmonics Generation

The waveform of the commercial power supply will be distorted if the commercial power supply contains excessive harmonics. Machines with such a commercial power supply will malfunction or generate excessive heat.

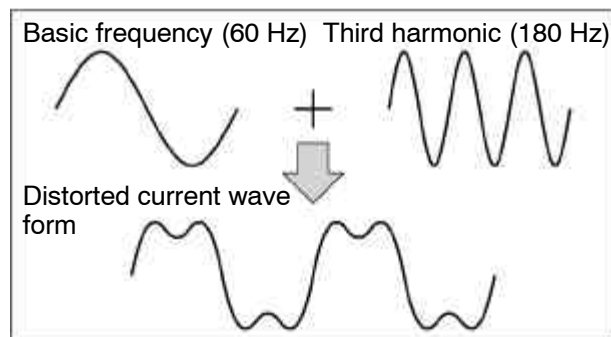

● Causes of Harmonics Generation

- Usually, electric machines have built-in circuitry that converts commercial AC power supply into DC power.

Such AC power, however, contains harmonics due to the difference in current flow between DC and AC.

Obtaining DC from AC Using Rectifiers and Capacitors

DC voltage is obtained by converting AC voltage into a pulsating one-side voltage with rectifiers and smoothing the pulsating one-side voltage with capacitors. Such AC current, however, contains harmonics.

Inverter

The Inverter as well as normal electric machines has an input current containing harmonics because the Inverter converts AC into DC. The output current of the Inverter is comparatively high. Therefore, the ratio of harmonics in the output current of the Inverter is higher than that of any other electric machine.

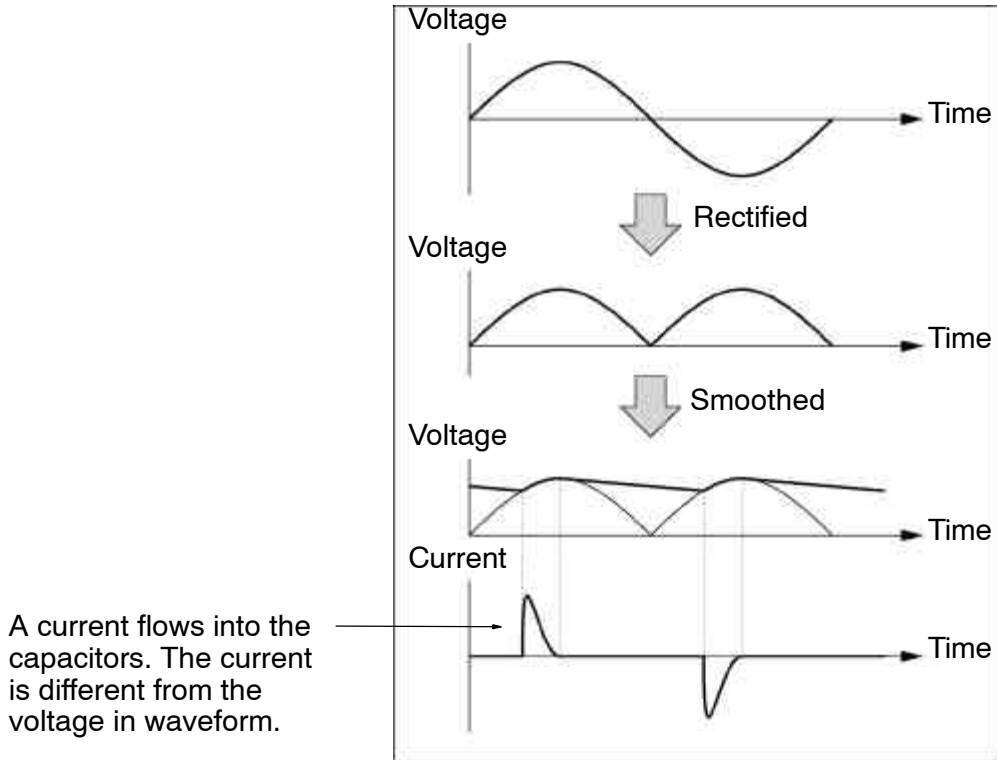

● Countermeasures with Reactors against Harmonics Generation

DC/AC Reactors

The DC reactor and AC reactor suppress harmonics and currents that change suddenly and greatly.

The DC reactor suppresses harmonics better than the AC reactor. The DC reactor used with the AC reactor suppresses harmonics more effectively.

The input power factor of the Inverter is improved by suppressing the harmonics of the input current of the Inverter.

Connection

Connect the DC reactor to the internal DC power supply of the Inverter after shutting OFF the power supply to the Inverter and making sure that the charge indicator of the Inverter turns OFF.

Do not touch the internal circuitry of the Inverter in operation, otherwise an electric shock or burn injury may occur.

Wiring Method

Please refer to Chapter 9 for more detailed information on AC and DC Reactors.

[With DC Reactor]

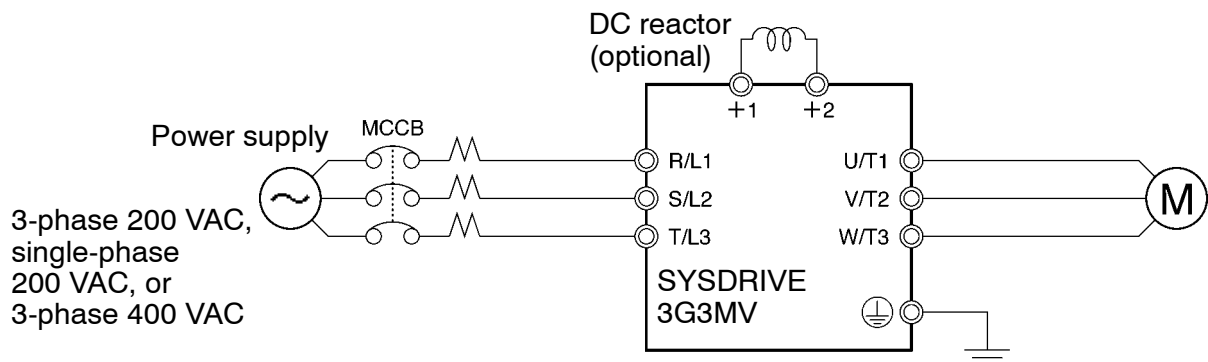

[With DC and AC Reactors]

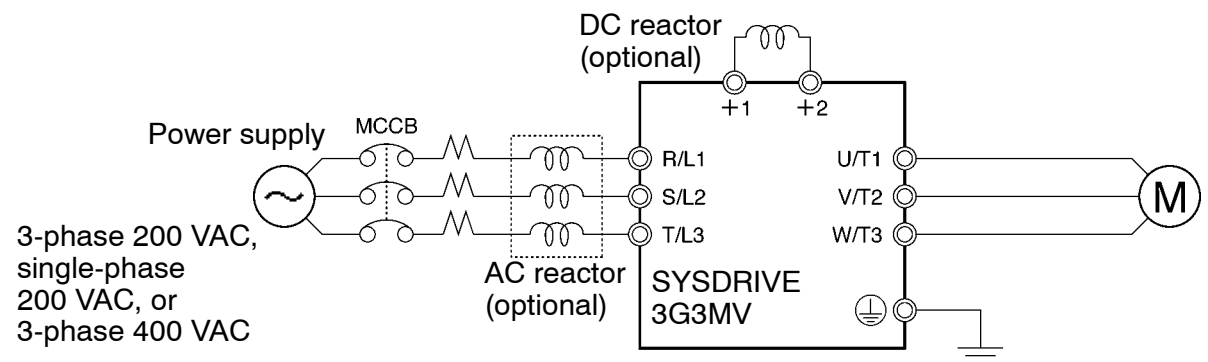

Reactor Effects

Harmonics are effectively suppressed when the DC reactor is used with the AC reactor as shown in the following table.

Harmonics suppression method	Harmonic generation rate (%)							
	5th harmonic	7th harmonic	11th harmonic	13th harmonic	17th harmonic	19th harmonic	23rd harmonic	25th harmonic
No reactor	65	41	8.5	7.7	4.3	3.1	2.6	1.8
AC reactor	38	14.5	7.4	3.4	3.2	1.9	1.7	1.3
DC reactor	30	13	8.4	5	4.7	3.2	3.0	2.2
DC and AC reactors	28	9.1	7.2	4.1	3.2	2.4	1.6	1.4

■ **Connecting the Braking Resistor and Braking Resistor Unit**

When running a load with a large inertia or a vertical axis, regeneration energy will return to the Inverter. If OV (overvoltage) is generated during deceleration, this indicates that the regeneration energy is exceeding the capacity of the Inverter. In this case, use a Braking Resistor or a Braking Resistor Unit.

- Connect the Braking Resistor as shown in the following diagram.

Note 1. When using a Braking Resistor, install a thermal relay to monitor the temperature of the resistor.

Note 2. When using a Braking Resistor or a Braking Resistor Unit, be sure to include a sequence whereby the power supply for the Inverter will be turned OFF in the case of abnormal overheating. Not doing so may result in burning.

- Braking Resistor: Use the output of the thermal relay used to monitor the temperature of the thermometer.
- Braking Resistor Unit: Use the error contact output of the Braking Resistor Unit.

- When using a Braking Resistor, be sure to set n092 (deceleration stall prevention selection) to “1” (without deceleration stall prevention).

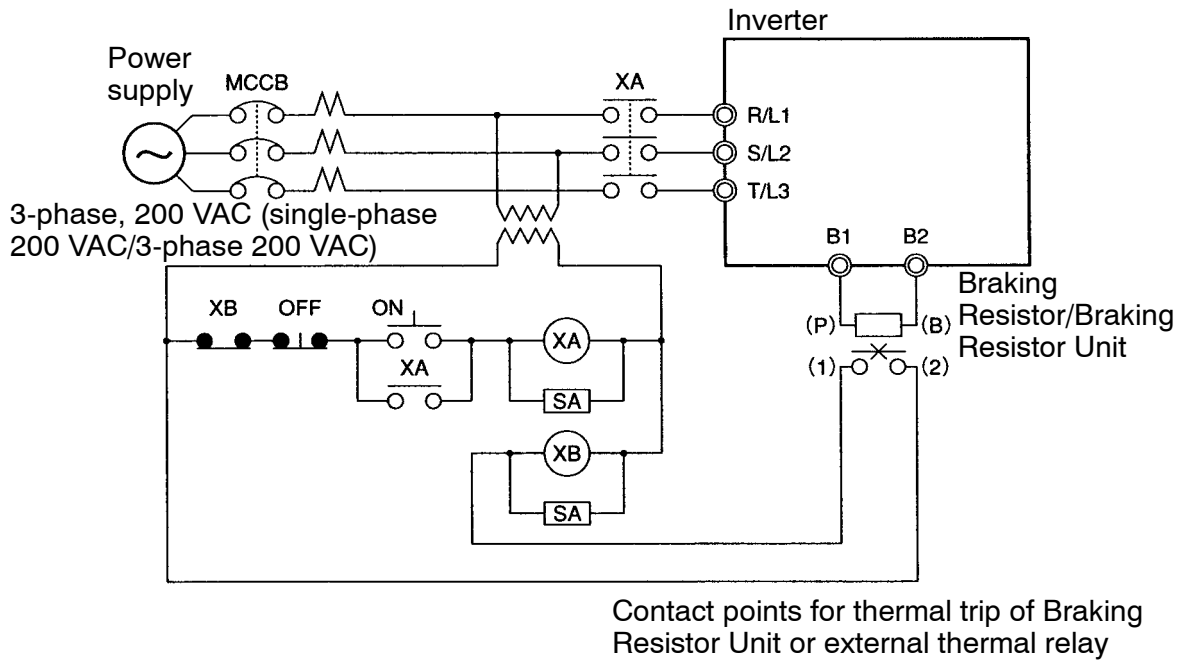

• Braking Resistors and Braking Resistor Units for 200-V-class Inverters

Inverter 3G3MV-	Braking Resistor (3% usage rate ED) 3G3IV-	Braking Resistor Unit (10% usage rate ED) 3G3IV-	Minimum connection resistance
A2001/AB001	PERF150WJ401 (400 Ω)	---	300 Ω
A2002/AB002			
A2004/AB004	PERF150WJ201 (200 Ω)	PLKEB20P7 (200 Ω, 70 W)	200 Ω
A2007/AB007			120 Ω
A2015/AB015	PERF150WJ101 (100 Ω)	PLKEB21P5 (100 Ω, 260 W)	60 Ω
A2022/AB022	PERF150WJ700 (70 Ω)	PLKEB22P2 (70 Ω, 260 W)	
A2040/AB040	PERF150WJ620 (62 Ω)	PLKEB23P7 (40 Ω, 390 W)	32 Ω
A2055	PERF500WJ360T (36 Ω)	PLKEB25P5 (30 Ω, 520 W)	9.6 Ω
A2075	PERF101WJ360T (36 Ω)	PLKEB27P5 (20 Ω, 780 W)	9.6 Ω

Note Do not use resistances less than than the minimum connection resistance value. Doing so may damage the Inverter.

Note The usage rate is shown as a percentage of the braking time in one cycle. If one cycle is 10 seconds, for example, one second of braking is possible using a Braking Resistor Unit (10% usage rate ED). If the usage rate is to be exceeded, a detailed regeneration energy calculation will be required.

● Braking Resistors and Braking Resistor Units for 400-V-class Inverters

Inverter 3G3MV-	Braking Resistor (3% usage rate ED) 3G3IV-	Braking Resistor Unit (10% usage rate ED) 3G3IV-	Minimum connection resistance
A4002	PERF150WJ751 (750 Ω)	PLKEB40P7 (750 Ω, 70 W)	750 Ω
A4004			510 Ω
A4007			
A4015	PERF150WJ401 (400 Ω)	PLKEB41P5 (400 Ω, 260 W)	240 Ω
A4022	PERF150WJ301 (300 Ω)	PLKEB42P2 (250 Ω, 260 W)	200 Ω
A4030	PERF150WJ401 (400 Ω) × 2	PLKEB43P7 (150 Ω, 390 W)	100 Ω
A4040	PERF150WJ401 (400 Ω) × 2	PLKEB43P7 (150 Ω, 390 W)	100 Ω
A4055	PERF500WJ360T (36 Ω)	PLKEB45P5 (100 Ω, 520 W)	32 Ω
A4075	PERF101WJ360T (36 Ω)	PLKEB47P5 (75 Ω, 780 W)	32 Ω

Note Do not use resistances less than than the minimum connection resistance value. Doing so may damage the Inverter.

Note The usage rate is shown as a percentage of the braking time in one cycle. If one cycle is 10 seconds, for example, one second of braking is possible using a Braking Resistor Unit (10% usage rate ED). If the usage rate is to be exceeded, a detailed regeneration energy calculation will be required.

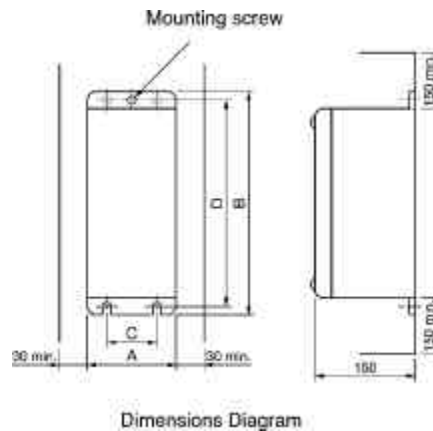

● The dimensions of a Braking Resistor Unit

Model No. 3G3IV-	Dimensions (mm)					Weight (kg)
	A	B	C	D	Mounting Screws	
PLKEB40P7	105	275	50	260	M5x3	3.0
PLKEB41P5	130	350	75	335	M5x4	4.5
PLKEB42P2	130	350	75	335	M5x4	4.5
PLKEB43P7	130	350	75	335	M5x4	5.0
PLKEB45P5	250	350	200	335	M6x4	7.5
PLKEB47P5	250	350	200	335	M6x4	8.5

2-2-4 Wiring Control Circuit Terminals

A control signal line must be 50 m maximum and separated from power lines.

The frequency reference must be input into the Inverter through shielded, twisted-pair wires.

■ Wiring Control I/O Terminals

Wire each control I/O terminal under the following conditions.

● Wires and Tightening Torque

Multi-function Contact Output (MA, MB, and MC)

Terminal screw size	Tightening torque N • m	Wire	Wire size mm ² (AWG)	Recommended wire size mm ² (AWG)	Cable
M3	0.5 to 0.6	Single wire	0.5 to 1.25 (20 to 16)	0.75 (18)	Cable with polyethylene sheath
		Stranded wire	0.5 to 1.25 (20 to 16)		

Sequential Input (S1 through S7 and SC), Multi-function Photocoupler Output (P1, P2, PC), RS-422/485 Communications (R+, R-, S+, S-) and Multi-function Analog Output (AM or AC), and Pulse Train Input (RP)

Terminal screw size	Tightening torque N • m	Wire	Wire size mm ² (AWG)	Recommended wire size mm ² (AWG)	Cable
M2	0.22 to 0.25	Single wire	0.5 to 1.25 (20 to 16)	0.75 (18)	Cable with polyethylene sheath
		Stranded wire	0.5 to 0.75 (20 to 18)		

Frequency Reference Input (FR, FS, and FC)

Terminal screw size	Tightening torque N • m	Wire	Wire size mm ² (AWG)	Recommended wire size mm ² (AWG)	Cable
M2	0.22 to 0.25	Single wire	0.5 to 1.25 (20 to 16)	0.75 (18)	Special cable with polyethylene sheath and shield for measurement use
		Stranded wire	0.5 to 0.75 (20 to 18)		

● **Solderless Terminals for Control Circuit Terminals**

The use of solderless terminals for the control circuit terminals is recommended because solderless terminals are easy to connect securely.

Note When using the following solderless terminal, make sure that the wire size is 0.5 mm².

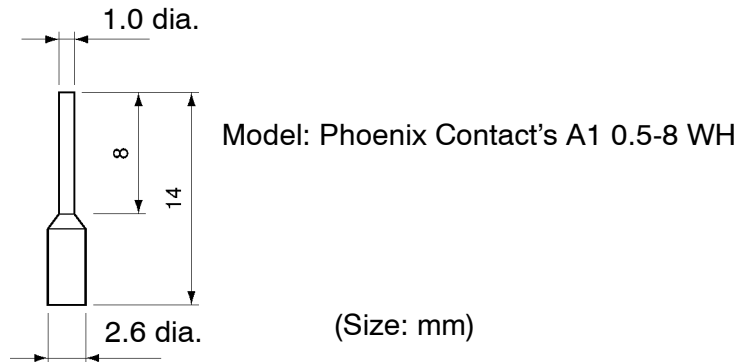

● **Wiring Method**

1. Loosen the terminal screws with a thin-slotted screwdriver.
2. Insert the wires from underneath the terminal block
3. Tighten the terminal screws firmly to a torque of 0.5 N•m.

Note 1. Always separate the control signal line from the main circuit cables and other power cables.

Note 2. Do not solder the wires to the control circuit terminals. The wires may not contact well with the control circuit terminals if the wires are soldered.

Note 3. The end of each wire connected to the control circuit terminals must be stripped for approximately 5.5 mm.

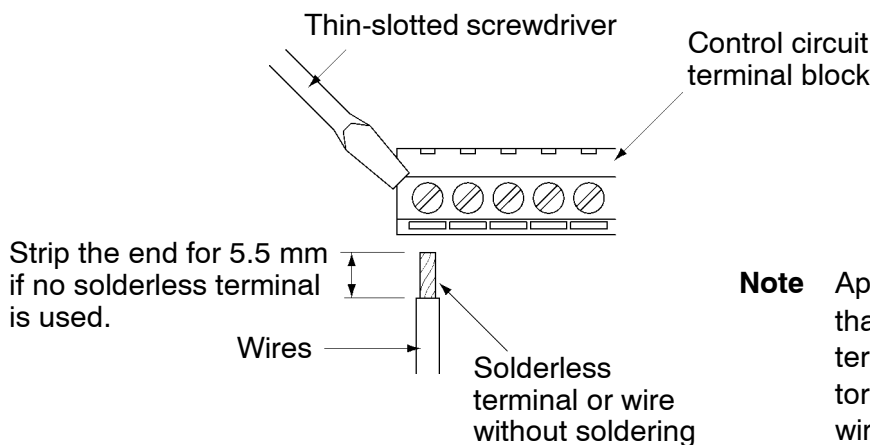

Note Applying a torque of greater than 0.5 N•m may damage the terminal block. If the tightening torque is insufficient, however, wires may be disconnected.

Note 4. Connect the shield to the ground terminal of the inverter. Do not ground the shield on control side.

Note 5. Cover the shield with tape so that the shield will not come into contact with other signal wires or machines.

■ Wiring Frequency Reference Input Terminals

Wire the frequency reference input terminals FR and FC as described below for executing frequency references with the D/A Unit for digital-to-analog data conversion or external power supply.

● Wires Used

Use shielded, twisted-pair wires for wiring in order to prevent the Inverter from malfunctioning due to noise.

Wire type	Wire size	Wire to be used
Single wire	0.5 to 1.25 mm ²	Polyethylene-shielded cable for measurement use
Stranded wire	0.5 to 0.75 mm ²	

● Solderless Terminals for Frequency Reference Input Terminals

The use of solderless terminals for the frequency reference input terminals is recommended because solderless terminals are easy to connect securely.

Note Make sure that the wire size is 0.5 mm² when using the following solderless terminal.

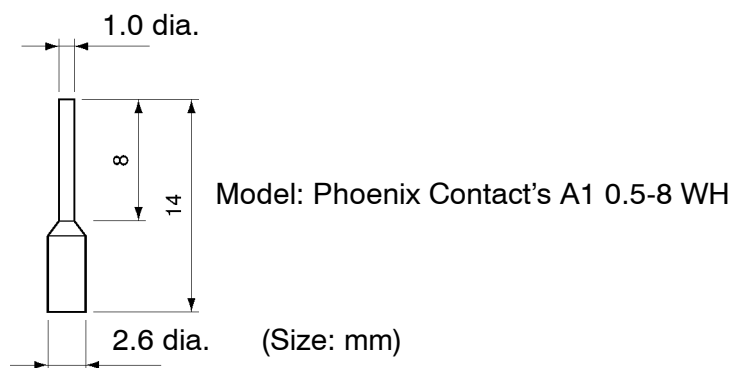

● Wiring Method

- The wiring method for the frequency reference input terminals is the same as that of the control I/O terminals.
- Always separate the control signal line from the main circuit cables and other power cables.
- Connect the shield to the ground terminal of the Inverter. Do not connect the shield to the load.
- Cover the shield with tape so that the shield will not come into contact with other signal wires or machines.

2-2-5 Conforming to EC Directive

The following description provides the wiring method of the Inverter to meet EC Directive requirements. If the following requirements are not satisfied, the whole equipment incorporating the Inverter will need further confirmation.

■ Standard Connection

● Main Circuit Terminals

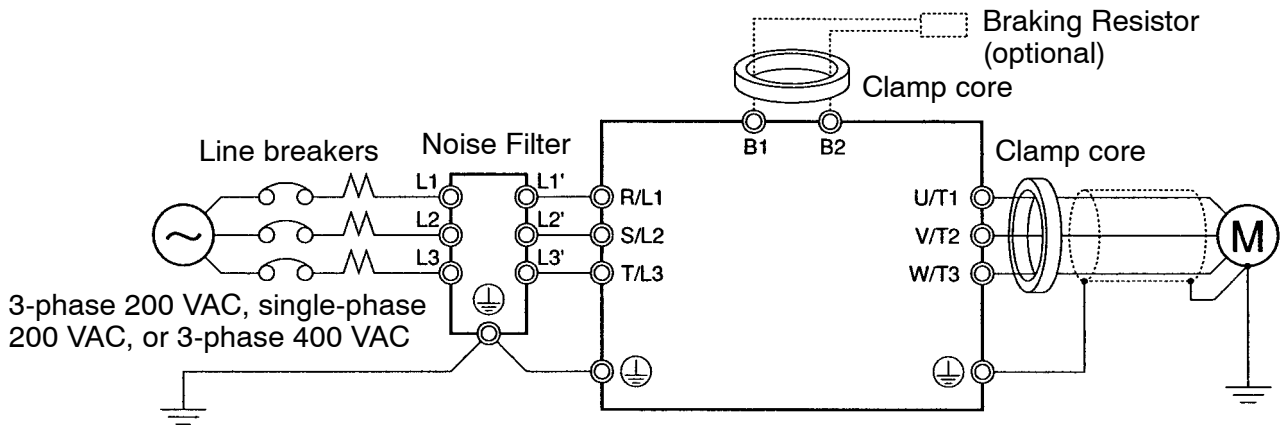

• Control Circuit Terminals

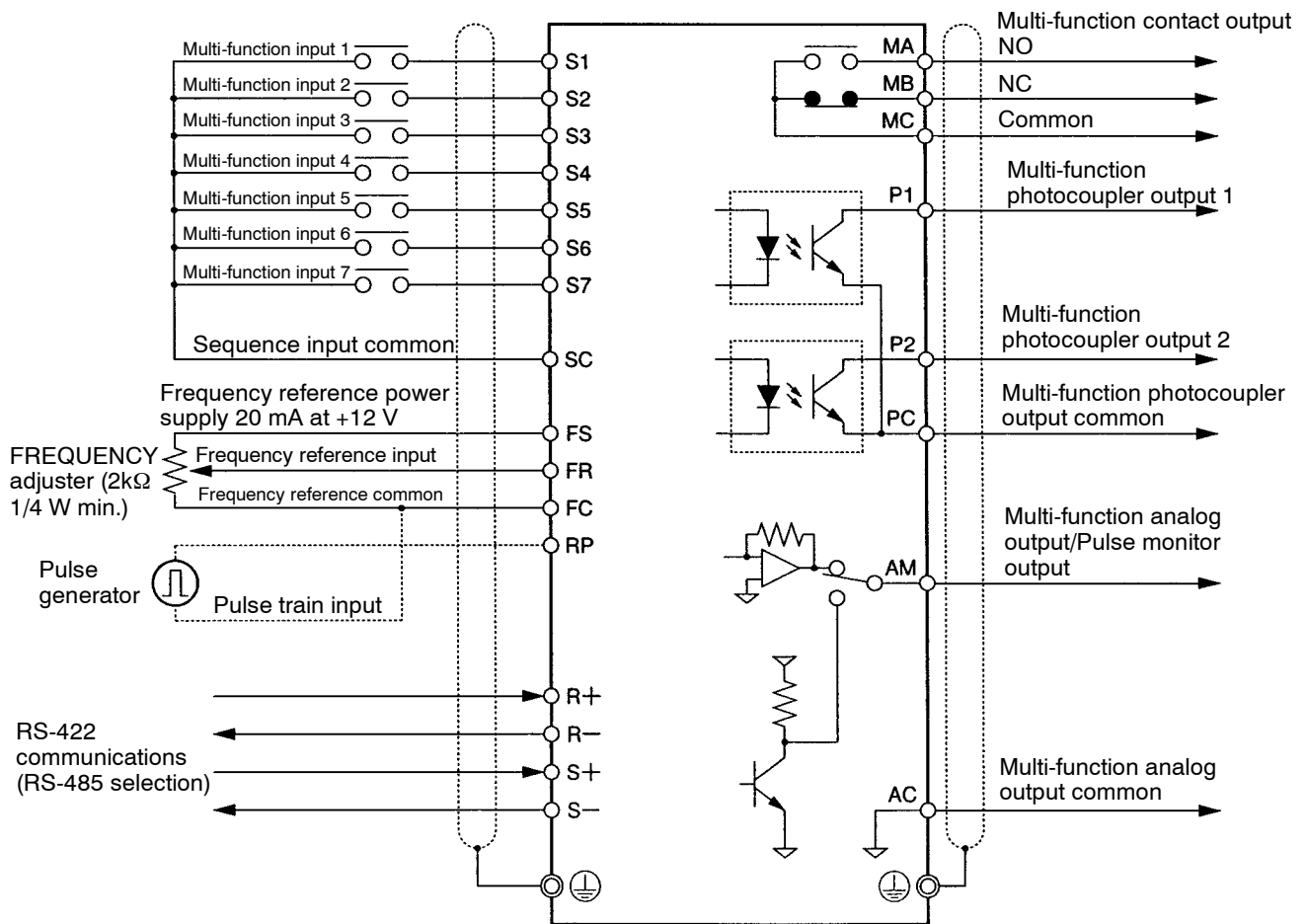

Note I/O signals can be connected to a single shielded cable.

■ **Conforming to EC Directives**

● **Wiring the Power Supply**

Make sure that the Inverter and Noise Filter are grounded together.

- Always connect the power input terminals (R/L1, S/L2, and T/L3) and power supply via a dedicated Noise Filter.
- Reduce the length of the ground wire as much as possible.
- Locate the Noise Filter as close as possible to the Inverter. Make sure that the cable length between the Noise Filter and the Inverter does not exceed 40 cm.
- The following Noise Filters are available (all footprint type).

3-phase 200-VAC Noise Filter

Inverter	3-phase 200-VAC Noise Filter	
Model 3G3MV-	Model 3G3MV-	Rated current (A)
A2001/A2002/A2004/A2007	PF12010-E	10
A2015/A2022	PF12020-E	16 to 20
A2040	PF12030-E	26 to 30
A2055/A2075	PF12050-E	50

Single-phase 200-VAC Noise Filter

Inverter	Single-phase 200-VAC Noise Filter	
Model 3G3MV-	Model 3G3MV-	Rated current (A)
AB001/AB002/AB004	PF11010-E	10
AB007/AB015	PF11020-E	20
AB022	PF11030-E	30
AB040	PF11040-E	40

3-phase 400-VAC Noise Filter

Inverter	3-phase 400-VAC Noise Filter	
Model 3G3MV-	Model 3G3MV-	Rated current (A)
A4002/A4004	PF13005-E	5
A4007/A4015/A4022	PF13010-E	10
A4030/A4040	PF13020-E	15 to 20
A4055/A4075	PF13030-E	30

● **Connecting a Motor to the Inverter**

- When connecting a motor to the Inverter, be sure to use a cable with a braided shield.
- Reduce the length of the cable as short as possible and ground the shield on the Inverter side as well as the motor side. Furthermore, it is recommended that a clamp core (Clamp Filter) be connected close to the output terminals of the Inverter.

Product	Model	Manufacturer
Clamp Filter	3G3IV-PFO OC2	RASMI

● **Wiring a Control Cable**

- Be sure to connect a cable with a braided shield to the control circuit terminals.
- Ground the shield on the Inverter side only.

● **Grounding the Shield**

In order to ground the shield securely, it is recommended that a cable clamp be directly connected to the ground plate as shown below.

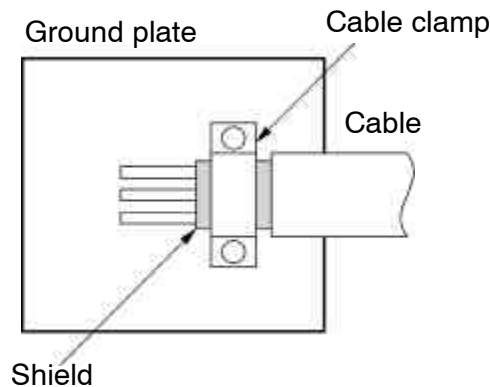

■ **Conforming to LVD**

- Always connect the Inverter and power supply via a molded case circuit breaker (MCCB) suitable to the Inverter for protecting the Inverter from damage that may result from short-circuiting.
- Use one MCCB per Inverter.
- Select a suitable MCCB from the following table.

200-V Models

Inverter Model 3G3MV-	MCCB (Mitsubishi Electric)	
	Type	Rated current (A)
A2001	NF30	5
A2002		5
A2004		5
A2007		10
A2015		20
A2022		20
A2040		30
A2055		50
A2075		60
AB001		NF30
AB002	5	
AB004	10	
AB007	20	
AB015	20	
AB022	40	
AB040	50	

400-V Models

Inverter Model 3G3MV-	MCCB (Mitsubishi Electric)	
	Type	Rated current (A)
A4002	NF30	5
A4004		5
A4007		5
A4015		10
A4022		10
A4030		20
A4040		20
A4055		30
A4075		30

Note To satisfy LVD requirements, the Inverter must be protected with a line breaker in case a short-circuiting accident occurs. When using a single line breaker to be shared with other Inverters or devices, make sure that the Inverters and devices will be fully protected if there is a one-point short-circuit, otherwise the Inverters and devices may be damaged.

The frequency reference power supply (FS) of the Inverter is of basic insulation construction. When connecting the Inverter to peripheral devices, be sure to increase the degree of insulation.

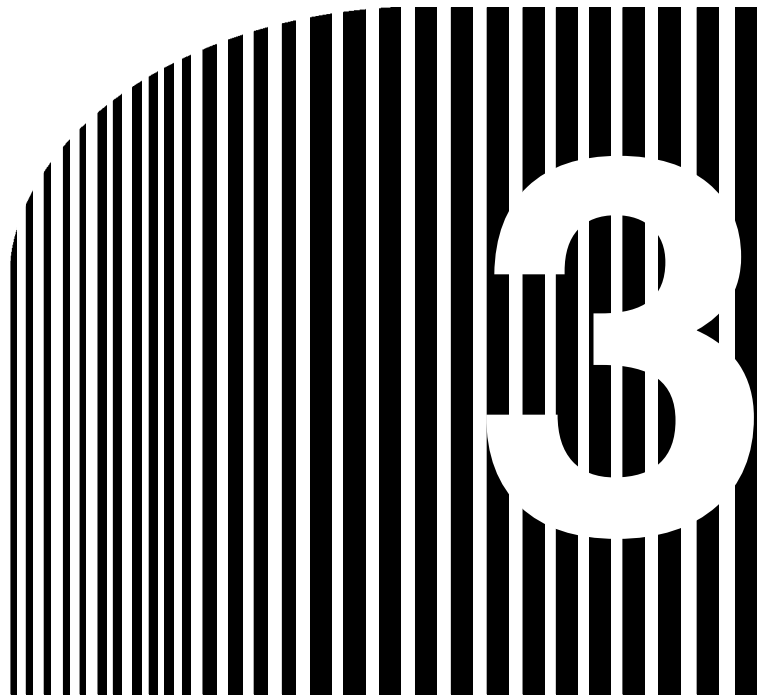

Chapter 3

- **Preparing for Operation and Monitoring** •

3-1 Nomenclature





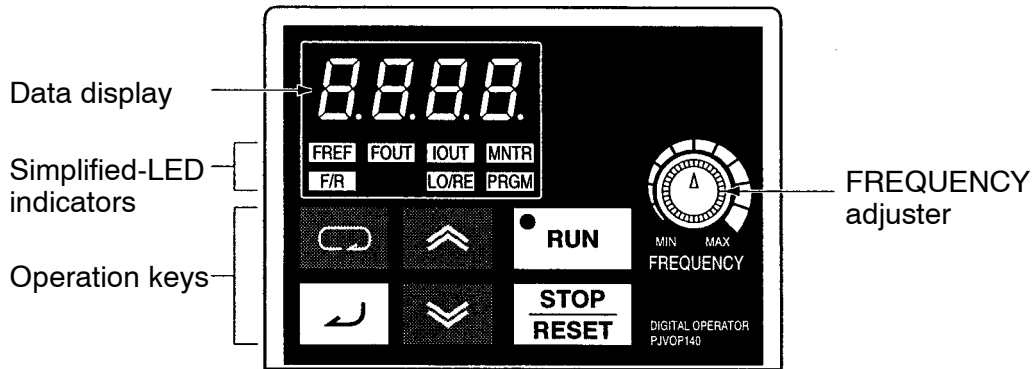

3-2 Parameter Copy and Verify Function

3-1 Nomenclature

3-1-1 Names of Parts and their Functions



Appearance	Name	Function
	Data display	Displays relevant data items, such as frequency reference, output frequency, and parameter set values.
	FREQ adjuster	Sets the frequency reference within a range between 0 Hz and the maximum output frequency.
	FREF indicator	The frequency reference can be monitored or set while this indicator is lit.
	FOUT indicator	The output frequency of the Inverter can be monitored while this indicator is lit.
	IOUT indicator	The output current of the Inverter can be monitored while this indicator is lit.
	MNTR indicator	The values set in U-01 through U-10 are monitored while this indicator is lit.
	F/R indicator	The direction of rotation can be selected while this indicator is lit, when operating the Inverter with the RUN Key.
	LO/RE indicator	The operation of the Inverter through the Digital Operator or according to the parameters set is selectable while this indicator is lit. Note This status of this indicator can be only monitored while the Inverter is in operation. Any RUN command input is ignored while this indicator is lit.

Appearance	Name	Function
	PRGM indicator	The parameters in n001 through n179 can be set or monitored while this indicator is lit. Note While the Inverter is in operation, the parameters can be only monitored and only some parameters can be changed. The RUN command input is ignored while this indicator is lit.
	Mode Key	Switches the simplified-LED (setting and monitor) item indicators in sequence. Parameter setting being made is canceled if this key is pressed before entering the setting.
	Increment Key	Increases multi-function monitor numbers, parameter numbers, and parameter set values.
	Decrement Key	Decreases multi-function monitor numbers, parameter numbers, and parameter set values.
	Enter Key	Enters multi-function monitor numbers, parameter numbers, and internal data values after they are set or changed.
	RUN Key	Starts the Inverter running when the 3G3MV is in operation with the Digital Operator.
	STOP/RESET Key	Stops the Inverter unless parameter n007 is set to disable the STOP Key. Functions as a Reset Key when an inverter error occurs (see note).

Note For safety reasons, the reset will not work while a RUN command (forward or reverse) is in effect. Wait until the RUN command is OFF before resetting the Inverter.

3-1-2 Outline of Operation

■ Selecting Indicators

Whenever the Mode Key is pressed, an indicator is lit in sequence beginning with the FREF indicator. The data display indicates the item corresponding to the indicator selected.

The FOUT or IOUT indicator will be lit by turning the Inverter ON again if the Inverter is turned OFF while the FOUT or IOUT indicator is lit. The FREF indicator will be lit by turning the Inverter ON again if the Inverter is turned OFF while an indicator other than the FOUT or IOUT indicator is lit.

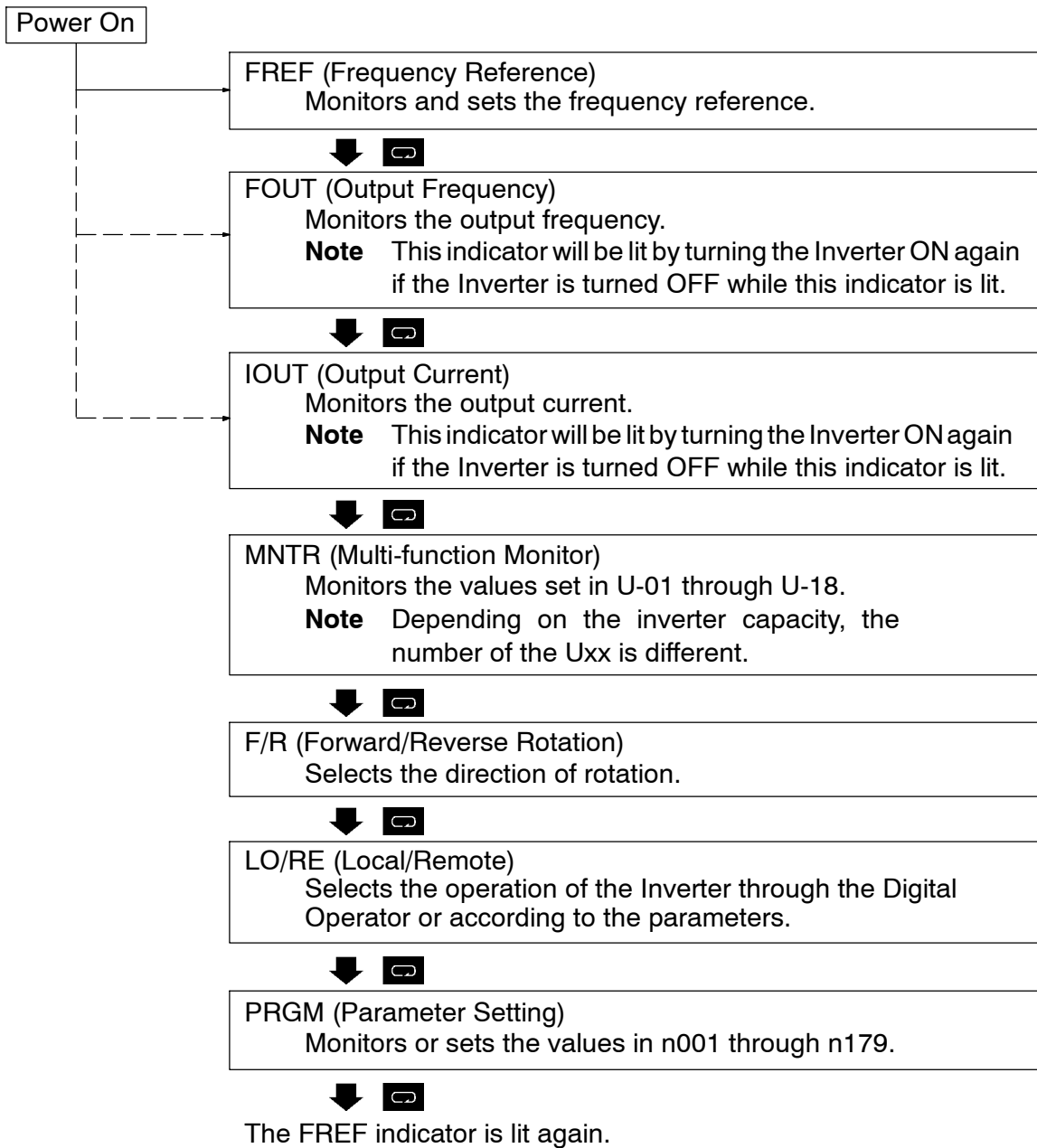

Note The setting unit of the frequency reference and output frequency is determined by the set value in n035. The default unit is Hz.

■ Example of Frequency Reference Settings



Key sequence	Indicator	Display example	Explanation
	FREF	6.0	Power On Note If the FREF indicator has not been lit, press the Mode Key repeatedly until the FREF indicator is lit.
▲ ▼	FREF	60.0 -----	Use the Increment or Decrement Key to set the frequency reference. The data display will flash while the frequency reference is set. (see note 1)
↵	FREF	60.0 _____	Press the Enter Key so that the set value will be entered and the data display will be lit. (see note 1)

Note 1. The Enter Key need not be pressed when n009 is 1. The frequency reference will change when the set value is changed with the Increment or Decrement Key while the data display is continuously lit.

Note 2. The frequency reference can be set in either of the following cases.

- Parameter n004 for frequency reference selection is set to 1 (i.e., frequency reference 1 is enabled) and the Inverter is in remote mode.
- Parameter n008 for frequency selection in local mode is set to 1 (i.e., the Digital Operator is enabled) and the Inverter is in local mode.
- Frequency references 2 through 8 are input for multi-step speed operation.

Note 3. The frequency reference can be changed, even during operation.

■ Example of Multi-function Display

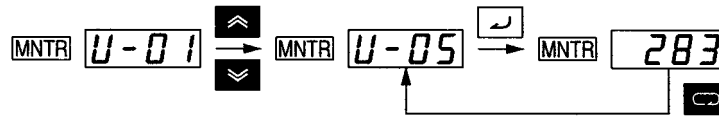

Key sequence	Indicator	Display	Explanation
	FREF	6.00	Power On
[Mode Key]	MNTR	U-01	Press the Mode Key repeatedly until the MNTR indicator is lit. U01 will be displayed.
[Up/Down Arrow]	MNTR	U-05	Use the Increment or Decrement Key to select the monitor item to be displayed.
[Enter Key]	MNTR	283	Press the Enter Key so that the data of the selected monitor item will be displayed.
[Mode Key]	MNTR	U-05	The monitor item will appear again by pressing the Mode Key.

● Status Monitor

Item	Display	Display unit	Function
U-01	Frequency reference	Hz (see note 1)	Monitors the frequency reference. (Same as FREF)
U-02	Output frequency	Hz (see note 1)	Monitors the output frequency. (Same as FOUT)
U-03	Output current	A	Monitors the output current. (Same as IOUT)
U-04	Output voltage	V	Monitors the internal output voltage reference value of the Inverter.
U-05	DC bus voltage	V	Monitors the DC voltage of the internal main circuit of the Inverter.
U-06	Input terminal status	---	Shows the ON/OFF status of inputs. <p>Terminal S1: Multi-function input 1 Terminal S2: Multi-function input 2 Terminal S3: Multi-function input 3 Terminal S4: Multi-function input 4 Terminal S5: Multi-function input 5 Terminal S6: Multi-function input 6 Terminal S7: Multi-function input 7</p>

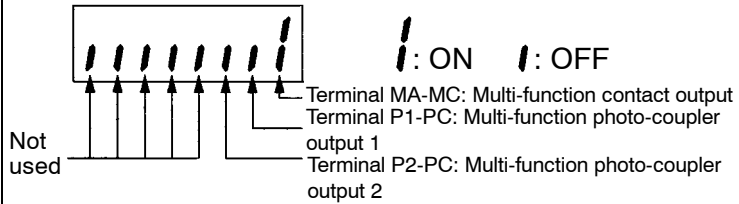
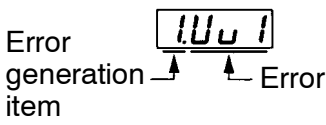
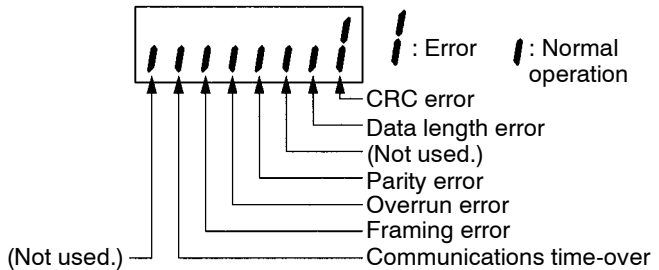
Item	Display	Display unit	Function
U-07	Output terminal status	---	Shows the ON/OFF status of outputs. 
U-08	Torque monitor	%	Displays the torque being currently output as a percentage of the rated motor torque. This display can only be made in vector control mode.
U-09	Error log (most recent one)	---	The four most recent errors can be checked.  <p>Note "1" means that the latest error is displayed. Press the Increment Key to display the second latest error. A maximum of four errors can be displayed.</p>
U-10	Software No.	---	OMRON use only.
U-11	Output power	W	Monitors the output power of the Inverter (see note 2).
U-13	Accumulated operating time	x10H	Monitor the accumulated operating time in 10-hour units. (See note 3.)
U-15	Communications error	---	Displays communications errors that occur during serial communications (RS-422/RS-485). The errors that are displayed have the same content as the serial communications error at register number 003D Hex. 
U-16	PID feedback	%	Monitors the PID control feedback (Max. frequency: 100%)
U-17	PID input	%	Monitors the PID control input (Max. frequency: 100%)
U-18	PID output	%	Monitors the PID output (Max. frequency: 100%)

Note 1. The setting unit of the frequency reference and output frequency is determined by the set value in n035. The default unit is Hz.

Note 2. The output power monitor is not displayed in vector control mode. '----' is displayed instead

Note 3. This function is provided for 200- and 400-V (5.5/7.5kW) inverters only.

■ Example of Forward/Reverse Selection Settings

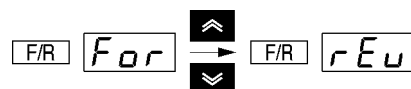

Key sequence	Indicator	Display example	Explanation
			Press the Mode Key repeatedly until the F/R indicator is lit. The present setting will be displayed. For: Forward; rEv: Reverse
			Use the Increment or Decrement Key to change the direction of motor rotation. The direction of motor rotation selected will be enabled when the display changes after the key is pressed.

Note The direction of motor rotation can be changed, even during operation.

■ Example of Local/Remote Selection Settings

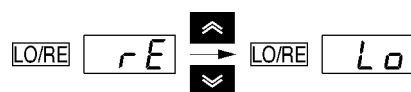

Key sequence	Indicator	Display example	Explanation
			Press the Mode Key repeatedly until the LO/RE indicator is lit. The present setting will be displayed. rE: Remote; Lo: Local
			Use the Increment or Decrement Key to set the Inverter to local or remote mode. The selection will be enabled when the display changes after the key is pressed.

Note 1. Local or remote selection is possible only when the Inverter is not in operation. The present setting can be monitored when the Inverter is in operation.

Note 2. Local or remote settings in multi-function input terminals can be changed through the multi-function input terminals only.

Note 3. Any RUN command input will be ignored while the LO/RE indicator is lit. To enable a RUN command, first turn OFF the RUN command and then press the Mode Key to display an item with the green indicator (FREF to MNTR). Finally, input the RUN command again.

■ Example of Parameter Settings

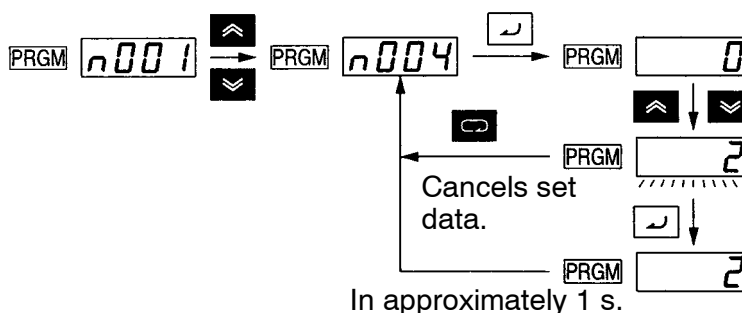

Key sequence	Indicator	Display example	Explanation
	FREF	000	Power On
[Mode Key]	PRGM	n001	Press the Mode Key repeatedly until the PRGM indicator is lit.
[Up] [Down]	PRGM	n004	Use the Increment or Decrement Key to set the parameter number.
[Enter]	PRGM	0	Press the Enter Key. The data of the selected parameter number will be displayed.
[Up] [Down]	PRGM	2	Use the Increment or Decrement Key to set the data. At that time the display will flash.
[Enter]	PRGM	2	Press the Enter Key so that the set value will be entered and the data display will be lit. (see note 1)
In approximately 1 s.	PRGM	n004	The parameter number will be displayed.

Note 1. To cancel the set value, press the Mode Key instead. The parameter number will be displayed.

Note 2. There are parameters that cannot be changed while the Inverter is in operation. Refer to the list of parameters. When attempting to change such parameters, the data display will not change by pressing the Increment or Decrement Key.

3-2 Parameter Copy and Verify Function

The Digital Operator of the 3G3MV Inverter has an EEPROM in which the set values in all the parameters and data on the capacity and software version of the Inverter can be stored.

By using the EEPROM, most parameter set values in the Inverter can be copied to another Inverter.

Note In the above case, however, the Inverters must have the same power supply specification and control mode (i.e., V/f or vector control mode). Some types of parameter set values cannot be copied.

3-2-1 Parameter for Copying and Verifying Set Values

• Use the following parameter to read, copy, and verify the set values.

Parameter	Register	Name	Description	Setting range	Unit of setting	Default setting	Changes during operation
n176	01B0	Parameter copy and verify function selection	The following items are selectable. rdy: Ready to accept the next command rEd: Reads the parameter CPy: Copies the parameter vFy: Verifies the parameter vA: Displays the capacity of the Inverter Sno: Displays the software version.	rdy to Sno	---	rdy	OK

Note No value can be copied or written while the Inverter is in operation.

■ Sequence of Display

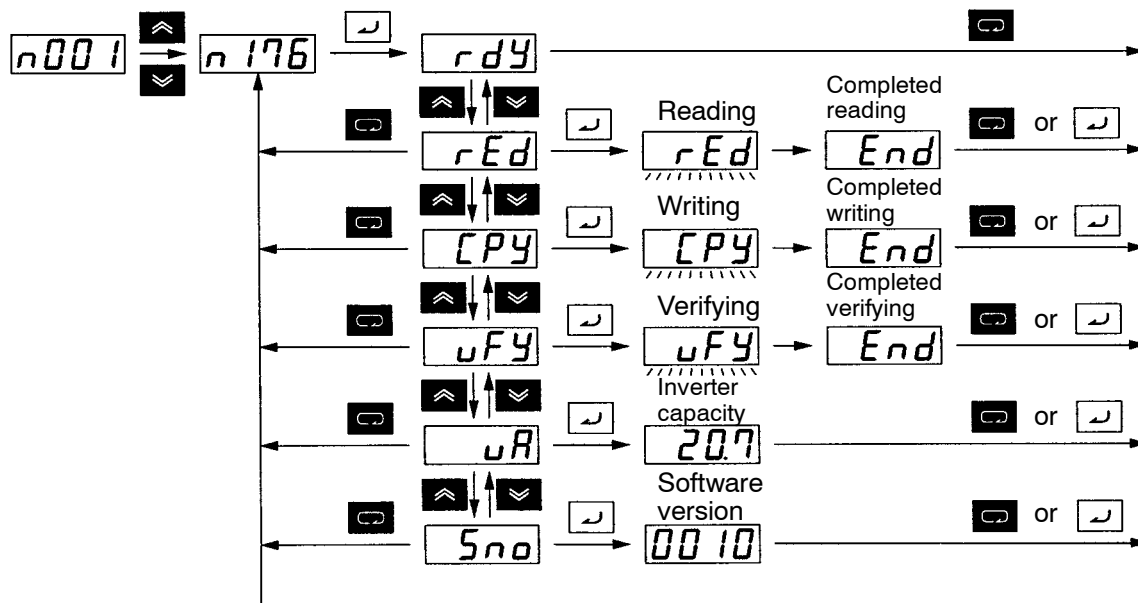

Note The following display is an example of the capacity displayed.

	20.7	
Voltage class		Max. applicable motor capacity
2: 3-phase 200 V		0.1: 0.1 kW
b: Single-phase 200 V		0.2: 0.25 kW/0.37 kW
4: Three-phase 400 V		0.4: 0.55 kW
		0.7: 1.1 kW
		1.5: 1.5 kW
		2.2: 2.2 kW
		3.0: 3.0 kW
		4.0: 4.0 kW
		5.5: 5.5 kW
		7.5: 7.5kW

3-2-2 Parameter Copying Procedure

- To copy parameter values to another Inverter, take the following steps.
 1. Set n001 for parameter write-prohibit selection/parameter initialization to 4.
 2. Set n177 for parameter read-prohibit selection to 1 so that the parameters can be read.
 3. Read the parameter set value with the EEPROM of the Digital Operator with the item rED selected.
 4. Turn OFF the Inverter and remove the Digital Operator.
 5. Mount the Digital Operator to the Inverter to which the parameters are to be copied. Then turn ON the Inverter.
 6. Copy the data in the EEPROM to the Inverter with the item CPY selected.
 7. Check that the data is written correctly with the item vFy selected.

- The above procedure is possible provided that the Inverters have the same power supply specification and control mode (i.e., V/f or vector control). It is not possible to copy parameters from a 200-V model to a 400-V model or from an Inverter that is in V/f control mode to another that is in vector control mode, for example.

Note 1. The following parameter set values or output frequency on hold cannot be copied.

- n176: Parameter copy function selection
- n177: Parameter read-prohibit selection
- n178: Error log
- n179: Software version

Note 2. The following parameter set values cannot be copied if the Inverters are different to each other in capacity.

- n011 to n017: V/f setting
- n036: Rated motor current
- n080: Carrier frequency
- n105: Torque compensation core loss
- n106: Rated motor slip
- n107: Motor wire-to-wire resistance
- n108: Motor leakage inductance
- n109: Torque compensation limit
- n110: Motor no-load current
- n140: Energy-saving control coefficient K2
- n158: Motor code

Note 3. Functions for 5.5/7.5kW Inverters cannot be copied to Inverters with different capacities.

■ **Setting n001 for Parameter Write-prohibit Selection/Parameter Initialization**

- No data can be written to n176 for parameter copy function selection unless the default setting is changed. To write data to this parameter, set n001 for parameter write-prohibit selection/parameter initialization to 4.

Parameter	Register	Name	Description	Setting range	Unit of setting	Default setting	Changes during operation
n001	0101	Parameter write-prohibit selection/parameter initialization	<p>Used to prohibit parameters to be written, sets parameters, or change the monitor range of parameters.</p> <p>Used to initialize parameters to default settings.</p> <p>0: Sets or monitor parameter n001. The parameters within a range from n002 to n179 can be monitored only.</p> <p>1: Sets or monitor the parameters within a range from n001 to n49 (i.e., function group 1 settings).</p> <p>2: Sets or monitor the parameters within a range from n001 to n79 (i.e., function groups 1 and 2 settings).</p> <p>3: Sets or monitor the parameters within a range from n001 to n119 (i.e., function groups 1 through 3 settings).</p> <p>4: Sets or monitor the parameters within a range from n001 to n179 (i.e., function groups 1 through 4 settings).</p> <p>5: Same operation as set to 4, but RUN command is expected in program mode.</p> <p>6: Clears the error log.</p> <p>8: Initializes parameters to default settings in 2-wire sequence.</p> <p>9: Initializes parameters in 3-wire sequence.</p> <p>10:For the USA, initializes parameter in 2-wire sequence.</p> <p>11:For the USA, initializes parameter in 3-wire sequence.</p>	0 to 9	1	1	No

● Parameter Settings in n001

Key sequence	Indicator	Display example	Explanation
	FREF	000	Power ON
	PRGM	n001	Press the Mode Key repeatedly until the PRGM indicator is lit. Check that “n001” is displayed.
	PRGM	1	Press the Enter Key. The data of the specified parameter number is displayed.
	PRGM	4	Press the Increment Key repeatedly to display the figure “4.” At that time the display flashes.
	PRGM	4	Press the Enter Key so that the set value will be entered and the data display will be lit.
In approximately 1 s.	PRGM	n001	The parameter number will be displayed again in approximately 1 s.

■ Reading the Parameter Set Value (rEd)

- To read the parameter set values in the Inverter with the EEPROM of the Digital Operator, set n176 for parameter copy function selection to rEd.

● Procedure to Read the Parameter Set Values

Key sequence	Indicator	Display example	Explanation
	FREF	n001	Check that the PRGM indicator is lit. If the PRGM is not lit, press the Mode Key repeatedly until the PRGM indicator is lit.
	PRGM	n176	Use the Increment or Decrement Key to display n176.
	PRGM	rdy	Press the Enter Key. Then “rdy” will be displayed.
	PRGM	rEd	Use the Increment Key to display “rEd.”
	PRGM	rEd	Press the Enter Key so that the parameter set values in the Inverter will be read by the EEPROM of the Digital Operator, during which the display flashes.
Completes	PRGM	End	When the set values have been all read, “End” will be displayed.
or	PRGM	n176	Press the Mode or Enter Key. The parameter number (n176) will be displayed again.

Note Be sure to set n177 for parameter read-prohibit selection to 1 so that the parameters can be read.

■ **Copying the Data in the EEPROM of the Digital Operator to another Inverter (CPy)**

- To copy the parameter set values to another Inverter from the EEPROM of the Digital Operator, set n176 for parameter copy function selection to CPy.
- When the parameter set values have been read, turn OFF the Inverter and remove the Digital Operator. Refer to 2-1-3 *Removing and Mounting the Covers* for details.
- Mount the Digital Operator to the Inverter to which the parameters are copied. Then turn ON the Inverter.
- Check that n001 for parameter write-prohibit selection/parameter initialization is set to 4 in the Inverter (i.e., values can be set in n001 through n179). If n001 is not set to 4, take the steps described above and set n002 to 4.

Note The above procedure is possible provided that the Inverters are the same in power supply specification and control mode (i.e., V/f or vector control).

● **Procedure to Copy the Parameter Set Values**

Key sequence	Indicator	Display example	Explanation
	FREF	000	Power ON
	PRGM	n001	Press the Mode Key repeatedly until the PRGM indicator is lit.
	PRGM	n176	Use the Increment or Decrement Key to display “n176.”
	PRGM	rdy	Press the Enter Key. Then “rdy” will be displayed.
	PRGM	CPy	Use the Increment Key to display “CPy.”
	PRGM	CPy ~~~~~	Press the Enter Key so that the parameter set values in the EEPROM of the Digital Operator will be copied to the Inverter, during which the display flashes.
Completes	PRGM	End	When the set values have been all copied, “End” will be displayed.
or	PRGM	n176	Press the Mode or Enter Key. The parameter number (n176) will be displayed again.

Note 1. Check and verify the set ranges and set values of the parameters written to the Inverter. If any error is found as a result, all the parameter set values will be prohibited and the previous values will be reset.

If a set range error results, the corresponding parameter number will flash. In the case of a verification error, “oP□” (□ is a figure) will flash.

Note 2. The following parameter set values or output frequency on hold cannot be copied.

- n176: Parameter copy function selection n178: Error log
- n177: Parameter read-prohibit selection n179: Software version

Note 3. The following parameter set values cannot be copied if the Inverters are different to each other in capacity.

- n011 to n017: V/f setting n108: Motor leakage inductance
- n036: Rated motor current n109: Torque compensation limit
- n080: Carrier frequency n110: Motor no-load current
- n105: Torque compensation core loss n140: Energy-saving control coefficient K2
- n106: Rated motor slip n158: Motor code
- n107: Motor wire-to-wire resistance

Note 4. Functions for 5.5/7.5kW Inverters cannot be copied to Inverters with different capacities.





■ **Verifying the Parameter Set Values (vFy)**

- In order to verify that the copied parameter set values in the Inverter coincide with those in the EEPROM of the Digital Operator, set n176 for parameter copy function selection to vFy.

Note The parameter set values can be verified provided that they are copied between the Inverters that are the same in power supply specification and control mode (i.e., V/f or vector control).

● **Procedure to Verify the Parameter Set Values**

Key sequence	Indicator	Display example	Explanation
	FREF	000	Power ON
	PRGM	n001	Press the Mode Key repeatedly until the PRGM indicator is lit.
	PRGM	n176	Use the Increment or Decrement Key to display “n176.”
	PRGM	rdy	Press the Enter Key. Then “rdy” will be displayed.
	PRGM	vFy	Use the Increment Key to display “vFy.”
	PRGM	vFy	Press the Enter Key so that the parameter set values are verified, during which the display flashes.

Key sequence	Indicator	Display example	Explanation
	PRGM	n011	If there is a parameter set value that does not coincide, the parameter number will flash.
	PRGM	600	Press the Enter Key so that the corresponding set value in the Inverter will flash.
	PRGM	500	Press the Enter Key again so that the corresponding set value in the EEPROM of the Digital Operator will flash.
	PRGM	uFy	Press the Increment Key so that verification will resume.
Completes	PRGM	End	When the set values have been all checked, "End" will be displayed.
 or 	PRGM	n176	Press the Mode or Enter Key. The parameter number (n176) will be displayed again.

Note 1. The above operation is interrupted when the STOP/RESET Key is pressed while the parameter number or parameter set value is flashing because the parameter set value does not coincide. "End" will be displayed. By pressing the Mode or Enter Key, the parameter number (n176) is displayed again.

Note 2. By attempting to verify the parameter set values in Inverters that are different in capacity, "vAE" flashes for a capacity error. Press the Enter Key to continue verifying the parameter set values. To cancel the operation, press the STOP/RESET Key.

3-2-3 Parameter Read-prohibit Selection (Prohibiting Data Written to the EEPROM of the Digital Operator)



- To store the parameter set values in the EEPROM of the Digital Operator, set n177 for parameter read-prohibit selection to 0. A protection error (PrE) will be detected by attempting to read the parameter set values in the Inverter with rEd set. This protects the parameter set values in the EEPROM from change. The PrE display is turned OFF by pressing the Mode Key.





Parameter	Register	Name	Description	Setting range	Unit of setting	Default setting	Changes during operation
n177	01B1	Parameter read-prohibit selection	Used to keep the data in the EEPROM of the Digital Operator on hold. 0: Parameter read-prohibit (No data can be written to the EEPROM) 1: Parameter read possible (Data can be written to the EEPROM)	0, 1	1	1	No

Note 1. No data can be written to n177 unless the default setting is changed. To write data to this parameter, set n001 for parameter write-prohibit selection/parameter initialization to 4.

Note 2. The parameter setting has an effect on the Digital Operator. If the Digital Operator with the data in the EEPROM protected is mounted to another Inverter, n117 will be set to 0 regardless of the n117 setting in the Inverter.

• Steps to Set Parameter Read-prohibit

Key sequence	Indicator	Display example	Explanation
	FREF	000	Power ON
	PRGM	n001	Press the Mode Key repeatedly until the PRGM indicator is lit.
	PRGM	n177	Use the Increment or Decrement Key to display "n177."
	PRGM	1	Press the Enter Key. The present set data will be displayed.

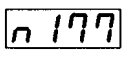
Key sequence	Indicator	Display example	Explanation
 	PRGM		Use the Increment or Decrement Key to display to set the data, during which the display flashes. 0: Parameter read-prohibit (No data can be written to the EEPROM) 1: Parameter read possible (Data can be written to the EEPROM)
	PRGM		Press the Enter Key so that the set value will be entered and the data display will be lit.
In approximately 1 s.	PRGM		The parameter number will be displayed again in approximately 1 s.

3-2-4 Parameter Copy or Verify Errors

- The following description provides information on errors that may result while the parameter set values are read, copied, or verified, and the remedies to be taken. The display flashes while displaying these errors.

Display	Name	Probable cause	Remedy
pre	Protection error	An attempt was made to read the parameter set values while n177 for parameter read-prohibit selection was set to 0.	Set n177 to 1 and retry after rechecking the necessity of reading the parameter set values.
rde	Read error	The parameter set values were not read correctly or a main-circuit low voltage was detected while the parameter set values were read.	Retry after checking that the voltage of the main circuit is normal.
cse	Checksum error	A checksum error resulted in the parameter set values in the EEPROM of the Digital Operator.	Read the parameter set values again and store them in the EEPROM.
nde	No data error	There are no parameter set values stored in the EEPROM of the Digital Operator.	Read the parameter set values and store them in the EEPROM.

Display	Name	Probable cause	Remedy
cpe	Copy error	An attempt was made to copy or verify the parameter set values while the Inverters are different to each other in voltage or control mode.	Check that the Inverters are the same in voltage and control mode. If either of them is different, no parameter set values can be either copied or verified. If the Inverters are different only in control mode, retry after changing the mode of the Inverter to which the parameter set values are to be written.
cye	Copy voltage error	Main-circuit low voltage is detected while the Inverter was copying the parameter set values.	Retry after checking that the voltage of the main circuit is normal.
uae	Capacity error	An attempt was made to verify the parameter set values while the Inverters were different to each other in capacity.	To continue verifying the parameter set values, press the Enter Key. To cancel the operation, press the STOP/RESET Key.
ife	Communications error	A communications error resulted between the Inverter and Digital Operator.	Retry after checking the connection between the Inverter and Digital Operator.

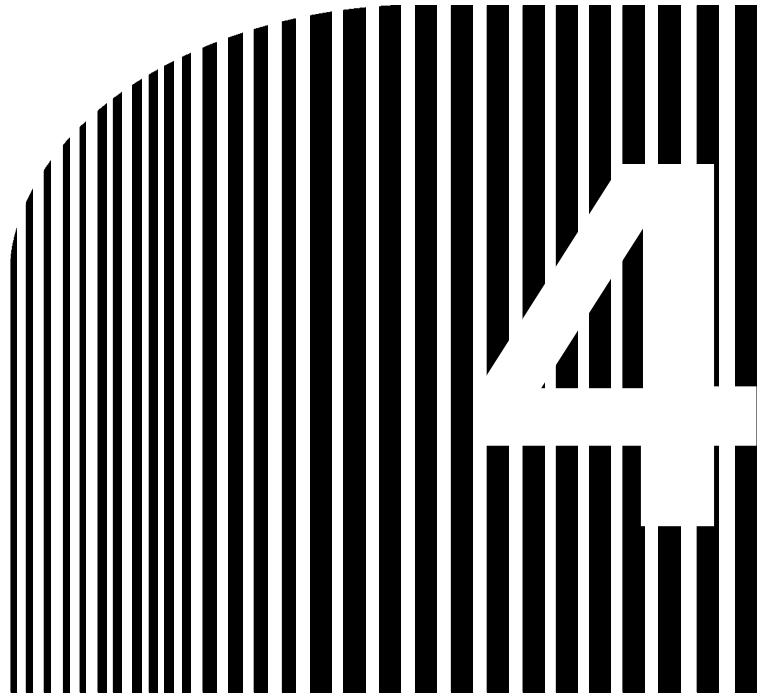











Chapter 4

• Test Run •

4-1 Procedure for Test Run

4-2 Operation Example

-  **WARNING** Turn ON the input power supply only after mounting the front cover, terminal covers, bottom cover, Operator, and optional items. Not doing so may result in electrical shock.
-  **WARNING** Do not remove the front cover, terminal covers, bottom cover, Operator, or optional items while the power is being supplied. Not doing so may result in electrical shock.
-  **WARNING** Do not operate the Operator or switches with wet hands. Doing so may result in electrical shock.
-  **WARNING** Do not touch the inside of the Inverter. Doing so may result in electrical shock.
-  **WARNING** Do not come close to the machine when using the error retry function because the machine may abruptly start when stopped by an alarm. Doing so may result in injury.
-  **WARNING** Do not come close to the machine immediately after resetting momentary power interruption to avoid an unexpected restart (if operation is set to be continued in the processing selection function after momentary power interruption is reset). Doing so may result in injury.
-  **WARNING** Provide a separate emergency stop switch because the STOP Key on the Operator is valid only when function settings are performed. Not doing so may result in injury.
-  **WARNING** Be sure confirm that the RUN signal is turned OFF before turning ON the power supply, resetting the alarm, or switching the LOCAL/REMOTE selector. Doing so while the RUN signal is turned ON may result in injury.
-  **Caution** Be sure to confirm permissible ranges of motors and machines before operation because the Inverter speed can be easily changed from low to high. Not doing so may result in damage to the product.
-  **Caution** Provide a separate holding brake when necessary. Not doing so may result in injury.

 **Caution**

Do not perform a signal check during operation. Doing so may result in injury or damage to the product.

4-1 Procedure for Test Run

1. Installation and Mounting

Install the Inverter according to the installation conditions. Refer to page 2-2. Ensure that the installation conditions are met.

2. Wiring and Connection

Connect to the power supply and peripheral devices. Refer to page 2-11. Select peripheral devices which meet the specifications and wire correctly.

3. Power Connection

Carry out the following pre-connection checks before turning ON the power supply.

- Always ensure that a power supply to the correct voltage is used and that the power input terminals (R/L1, S/L2, and T/L3) are wired correctly.

3G3MV-A2□: 3-phase 200 to 230 VAC

3G3MV-AB□: Single-phase 200 to 240 VAC (Wire R/L1 and S/L2)

3G3MV-A4□: 3-phase 380 to 460 VAC

- Make sure that the motor output terminals (U/T1, V/T2, and W/T3) are connected to the motor correctly.
- Ensure that the control circuit terminals and the control device are wired correctly. Make sure that all control terminals are turned OFF.
- Set the motor to no-load status (i.e., not connected to the mechanical system).
- Having conducted the above checks, connect the power supply.

4. Check the Display Status

Check to be sure that there are no faults in the Inverter.

- If the display at the time the power is connected is normal, it will read as follows:

RUN indicator: Flashes

ALARM indicator: OFF

Simplified-LED (setting/monitor) indicators: FREF, FOUT, or IOU is lit.

Data display: Displays the corresponding data of the indicator that is lit.

- When a fault has occurred, the details of the fault will be displayed. In that case, refer to *Chapter 8 Maintenance Operations* and take necessary remedies.

5. Initializing Parameters

Initialize the parameters.

- Set n001 to 8 for initialization in 2-wire sequence.

6. Setting Parameters

Set the parameters required for a test run.

- Perform the test run in V/f control mode. The control mode needs to be set to V/f control since it will not be initialized. Set the rated motor current in order to prevent the motor from burning due to overloading.

7. No-load Operation

Start the no-load motor using the Digital Operator.

- Set the frequency reference using the Digital Operator and start the motor using key sequences.

8. Actual Load Operation

Connect the mechanical system and operate using the Digital Operator.

- When there are no difficulties using the no-load operation, connect the mechanical system to the motor and operate using the Digital Operator.

9. Operation

Basic Operation:

Operation based on the basic settings required to start and stop the Inverter. Refer to page 5-1.

Advanced Operation:

Operation that uses PID control or other functions. Refer to page 6-1.

- For operation within standard parameters, refer to *Chapter 5 Basic Operation*.
- Refer to *Chapter 5 Basic Operation* and *Chapter 6 Advanced Operation* for the various advanced functions, such as energy-saving control, PID control, stall prevention, carrier frequency setting, overtorque detection, torque compensation, and slip compensation.

4-2 Operation Example

1	Power Connection
----------	-------------------------

■ Checkpoints before Connecting the Power Supply

- Check that the power supply is of the correct voltage and that the motor output terminals (R/L1, S/L2, and T/L3) are connected to the motor correctly.
 - 3G3MV-A2□: Three-phase 200 to 230 VAC
 - 3G3MV-AB□: Single-phase 200 to 240 VAC (Wire R/L1 and S/L2)
 - 3G3MV-A4□: Three-phase 380 to 460 VAC
- Make sure that the motor output terminals (U/T1, V/T2, and W/T3) are connected to the motor correctly.
- Ensure that the control circuit terminals and the control device are wired correctly. Make sure that all control terminals are turned OFF.
- Set the motor to no-load status (i.e., not connected to the mechanical system).

■ Connecting the Power Supply

- After conducting the above checks, connect the power supply.

2	Check the Display Status
----------	---------------------------------

- If the display is normal when the power is connected, it will read as follows:

Normal

RUN indicator: Flashes

ALARM indicator: Off

Simplified-LED (setting/monitor) indicators: FREF, FOUT, or IOU is lit.

Data display: Displays the corresponding data for the indicator that is lit.

- When a fault has occurred, the details of the fault will be displayed. In that case, refer to *Chapter 8 Maintenance Operations* and take necessary action.

Fault

RUN indicator: Flashes

ALARM indicator: Lit (fault detection) or flashes (alarm detection)

Simplified-LED (setting/monitor) indicators: FREF, FOUT, or IOU is lit.

Data display: The fault code, such as UV1, is displayed. The display will differ depending on the type of fault.

3	Initializing Parameters
----------	--------------------------------

- Initialize the parameters using the following procedure.
- To initialize the parameters, set n01 to 8.











Key sequence	Indicator	Display example	Explanation
	FREF		Power On
	PRGM		Press the Mode Key repeatedly until the PRGM indicator is lit.
	PRGM		Press the Enter Key. The data of n001 will be displayed.
	PRGM		Use the Increment or Decrement Key to set n01 to 8. The display will flash.
	PRGM		Press the Enter Key so that the set value will be entered and the data display will be lit.
---	PRGM		Parameter n001 will be initialized and reset to 1 from 8.
In approximately 1 s.	PRGM		The parameter number will be displayed.

4	Setting the Motor Current Parameter
----------	--

- Run the Inverter in V/f control mode for trial operation. The control mode is not initialized. Therefore, set n002 to 0 for V/f control. Set the motor current parameter in n036 in order to prevent the motor from burning due to overloading.

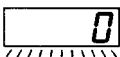
■ **Control Mode Setting**

Parameter	Register	Name	Description	Setting range	Unit of setting	Default setting	Changes during operation
n002	0102	Control mode selection	Sets the control mode for the Inverter. 0: V/f control mode 1: Vector control mode Note 1. The control mode is not initialized with n001 settings. Note 2. There are parameters that are changed according to the set value in n002. For details, refer to <i>5-1-2 Setting the Control Mode (n002)</i> .	0, 1	1	0	No

Key sequence	Indicator	Display example	Explanation
	PRGM		The parameter number is displayed.
	PRGM		Use the Increment or Decrement Key to display “n002.”
	PRGM		Press the Enter Key to display the set value in n002.
	PRGM		Use the Increment or Decrement key to set n002 to 0 unless the value is already set to 0, during which the display flashes.
	PRGM		Press the Enter Key so that the set value will be entered and the data display will be lit.
In approximately 1 s.	PRGM		The parameter number will be displayed again in approximately 1 s.

■ Setting the Rated Motor Current

Parameter	Register	Name	Description	Setting range	Unit of setting	Default setting	Changes during operation
n036	0124	Rated motor current	Used to set the rated motor current (A) used for the reference current of motor overload detection (OL1). Note 1. The default setting for the rated motor current is the standard rated current of the maximum applicable motor. Note 2. Motor overload detection (OL1) is disabled by setting the parameter to 0.0.	0.0% to 150% (A) of rated output current of the Inverter	0.1 A	See note 1 under "Description."	No















Key sequence	Indicator	Display example	Explanation
	PRGM	n002	The parameter number is displayed.
▲ ▼	PRGM	n036	Use the Increment or Decrement Key to display "n036."
↵	PRGM	19	Press the Enter Key to display the set value in n036.
▲ ▼	PRGM	18	Use the Increment or Decrement Key to set n036 to the rated motor current, during which the display flashes.
↵	PRGM	18	Press the Enter Key so that the set value will be entered and the data display will be lit.
In approximately 1 s.	PRGM	n036	The parameter number will be displayed again in approximately 1 s.

5	No-load Operation
----------	--------------------------

- Start the no-load motor (i.e., not connected to the mechanical system) using the Digital Operator.

Note Before operating the Digital Operator, check that the FREQ adjuster is set to MIN.

■ **Forward/Reverse Rotation with the Digital Operator**

Key sequence	Indicator	Display example	Explanation
			Monitors the frequency reference.
			Press the RUN Key. The RUN Indicator will be lit.
			Turn the FREQ adjuster clockwise slowly. The monitored frequency reference will be displayed. The motor will start rotating in the forward direction according to the frequency reference.
			Press the MODE Key to turn ON the F/R indicator. "For" will be displayed.
			Use the Increment or Decrement Key to change the direction of motor rotation. The direction of motor rotation selected will be enabled when the display is changed after the Key is pressed.

- After changing the frequency reference or the rotation direction, check that there is no vibration or abnormal sound from the motor.
- Check that no faults have occurred in the Inverter during operation.

■ **Stopping the Motor**

- On completion of operating the motor in the no-load state in the forward or reverse direction, press the STOP/RESET Key. The motor will stop. (The RUN indicator will flash until the motor stops.)

6	Actual Load Operation
----------	------------------------------

- After checking the operation with the motor in no-load status, connect the mechanical system and operate with an actual load.

Note Before operating the Digital Operator, check that the FREQ adjuster is set to MIN.

■ **Connecting the System**

- After confirming that the motor has stopped completely, connect the mechanical system.
- Be sure to tighten all the screws when fixing the motor axis in the mechanical system.

■ Operation Using the Digital Operator

- In case a fault occurs during operation, make sure the Stop Key on the Digital Operator is easily accessible.
- Use the Digital Operator in the same way as no-load operation.
- First set the frequency reference to a low speed of one tenth the normal operating speed.

■ Checking the Operating Status

- Having checked that the operating direction is correct and that the machine is operating smoothly at slow speed, increase the frequency reference.
- After changing the frequency reference or the rotation direction, check that there is no vibration or abnormal sound from the motor. Check the monitor display (IOUT or multi-function monitor U-03) to ensure that the output current is not becoming excessive.

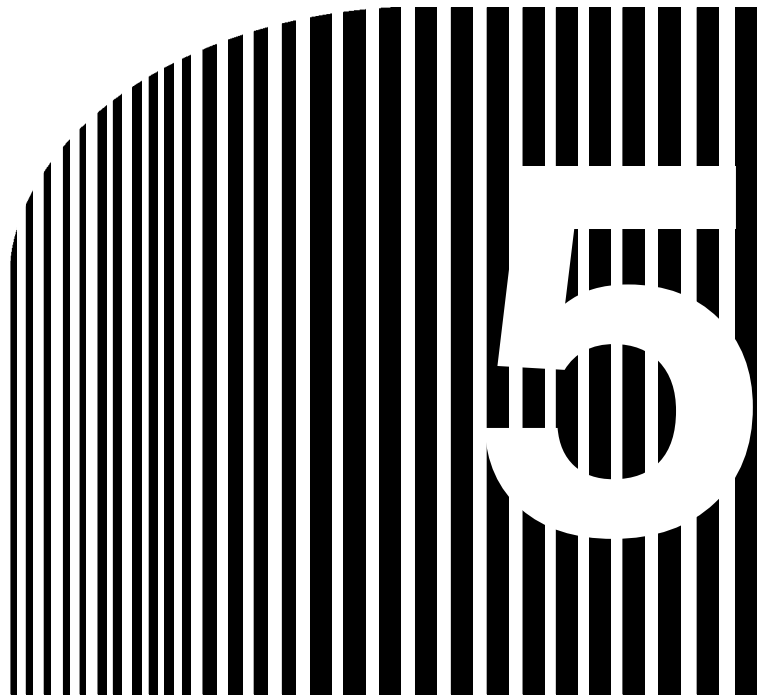

Chapter 5

• Basic Operation •

- 5-1 Initial Settings
- 5-2 Operation in Vector Control
- 5-3 Operation in V/f Control
- 5-4 Setting the Local/Remote Mode
- 5-5 Selecting the Operation Command
- 5-6 Setting the Frequency Reference
- 5-7 Setting the Acceleration/Deceleration Time
- 5-8 Selecting the Reverse Rotation-prohibit
- 5-9 Selecting the Stopping Mode
- 5-10 Multi-function I/O
- 5-11 Multi-function Analog Output and Pulse Monitor Output

This section explains the basic settings required to operate and stop the Inverter.

The settings of parameters described here will be sufficient for simple Inverter operations.

First, make these basic settings, then skip to the explanations of those special functions, even when your application requires special functions, such as energy-saving control, PID control, stall prevention, carrier frequency setting, overtorque detection, torque compensation, slip compensation. Refer to *Chapter 6 Advanced Operation*.

5-1 Initial Settings

- The following initial settings are required.

Parameter Write-prohibit Selection/Parameter Initialization (n001): Set n001 to 4 so that n001 through n179 can be set or displayed.

Control Mode Selection (n002): Set to V/f or vector control mode according to the application.

5-1-1 Setting the Parameter Write-prohibit Selection/Parameter Initialization (n001)

- Set n001 to 4 so that n001 through n179 can be set or displayed.

n001	Parameter Write-prohibit Selection/Parameter Initialization	Register	0101 Hex	Changes during operation	No
Setting range	0 to 9	Unit of setting	1	Default setting	1

Note This parameter makes it possible to write-prohibit parameters, change the parameter set or displayed range, or initialize all parameters to default values.

Set Values

Value	Description
0	Displays and sets n001. Parameters from n002 to n179 can be displayed only.
1	Sets or monitors parameters n001 through n049 (i.e., function group 1 settings).
2	Sets or monitors parameters n001 through n079 (i.e., function groups 1 and 2 settings).
3	Sets or monitors parameters n001 through n119 (i.e., function groups 1 through 3 settings).
4	Sets or monitors parameters n001 through n179 (i.e., function groups 1 through 4 settings).
5	Same operation as set to 4, but RUN command is accepted in program mode.
6	Clears the error log.
8	Initializes parameters to default settings in 2-wire sequence. (See note.)
9	Initializes parameters in 3-wire sequence. (See note.)
10	For the USA, initializes parameters in 2-wire sequence (See note)
11	For the USA, initializes parameters in 3-wire sequence (See note)

Note The set value in n002 is not initialized with n001 set to 8,9,10 or 11..

Each of the following parameters is initialized according to the preset control mode. The default value varies with the control mode. For details, refer to page 5-3.

n014 (middle output frequency), n015 (middle output frequency voltage), n016 (minimum output frequency), n017 (minimum output frequency voltage), n104 (torque compensation primary-delay time constant), n111 (slip compensation gain), n112 (slip compensation primary-delay time constant)

5-1-2 Setting the Control Mode (n002)

- The 3G3MV Inverter operates in vector or V/f control mode to be selected according to the application.
- These two modes have the following characteristics.

Vector Control Mode

The Inverter in vector control mode calculates the vector of the operating condition of the motor. Then the 150% rated output torque of the motor is provided at an output frequency of 1 Hz. Vector control provides more powerful motor control than V/f control and makes it possible to suppress speed fluctuation regardless of changes in loads. Normally set the Inverter to this mode.

V/f Control Mode

This mode, which is used by conventional general-purpose inverters, is convenient when replacing a conventional model with the 3G3MV Inverter because the Inverter in this mode can be operated without considering the constants of the motor. Furthermore, set the Inverter to this mode if the Inverter is connected to more than one motor or special motors such as high-speed motors.

n002	Control Mode Selection	Register	0102 Hex	Changes during operation	No
Setting range	0, 1	Unit of setting	1	Default setting	0

Note This parameter is used for selecting the control mode of the Inverter.

Set Values

Value	Description
0	V/f control mode
1	Vector control mode (open loop)

Note 1. This parameter is not initialized by setting n001 (parameter write-prohibit selection/parameter initialization) to 8 or 9 for parameter initialization.

Note 2. Each of the following parameters is initialized according to the control mode set in this parameter. The default value varies with the control mode. Therefore, be sure to set the following parameters after setting the control mode in n002.

Parameter	Name	Default value	
		V/f control (Set value: 0)	Vector control (Set value: 1)
n014	Middle output frequency	1.5 Hz	3.0 Hz
n015	Middle output frequency voltage	12.0 V (24.0 V) (see note 2)	11.0 V (22.0 V)
n016	Minimum output frequency	1.5 Hz	1.0 Hz
n017	Minimum output frequency voltage	12.0 V (24.0 V) (see note 2)	4.3 V (8.6 V)
n104	Torque compensation primary-delay time constant	0.3 s	0.2 s
n111	Slip compensation gain	0.0	1.0
n112	Slip compensation primary-delay time constant	2.0 s	0.2 s

Note 1. Values in parentheses are for 400-V models.

Note 2. For 5.5- and 7.5-kW Inverters, this value is set to 10.0 V for 200-V-class models and to 20.0 V for 400-V-class models.

5-2 Operation in Vector Control

The Inverter in vector control mode calculates the vector of the operating condition of the motor. Then the 150% rated output torque of the motor is provided at an output frequency of 1 Hz. Vector control provides more powerful motor control than V/f control and makes it possible to suppress speed fluctuation with changes in loads.

To operate the Inverter in vector control mode, be sure to set the following parameters.

n036 (rated motor current), n106 (rated motor slip), n107 (motor wire-to-wire resistance), n110 (motor no-load current)

■ Setting the Rated Motor Current (n036)

- Check the motor nameplate and set this parameter to the rated current.
- This parameter is used as a vector control constant. Be sure to set the parameter correctly. This set value is also used for determining the electronic thermal characteristics to protect the motor from overheating. The correct set value protects the motor from burning that may result from overloading.

n036	Rated Motor Current	Register	0124 Hex	Changes during operation	No
Setting range	0.0% to 150% (A) of rated output current of the Inverter	Unit of setting	0.1 A	Default setting	See note

Note The default setting for this parameter is the standard rated current of the maximum applicable motor.

■ Setting the Rated Motor Slip (n106)

- Set the rated motor slip in n106.
- This parameter is used as a vector control constant. Be sure to set the parameter correctly. This set value is used for slip compensation as well.
- Calculate the rated motor slip value from the rated frequency (Hz) and rpm on the motor nameplate by using the following formula.

$$\text{Rated slip value (Hz)} = \text{Rated frequency (Hz)} - \text{Rated rpm} \times \text{Number of poles} / 120$$

n106	Rated Motor Slip	Register	016A Hex	Changes during operation	Yes
Setting range	0.0 to 20.0 (Hz)	Unit of setting	0.1 Hz	Default setting	See note

Note The default setting for this parameter is the standard motor slip of the maximum applicable motor.

■ Setting the Motor Phase to neutral Resistance (n107)

- Set this parameter to 1/2 of the phase-to-phase resistance of the motor, or phase to neutral resistance.
- Contact the manufacturer of the motor for the above resistance.
- This parameter is used as a vector control constant. Be sure to set the parameter correctly.

n107	Motor Phase to neutral Resistance	Register	016B Hex	Changes during operation	No
Setting range	0.000 to 65.50 (Ω)	Unit of setting	See note 1	Default setting	See note 2

Note 1. The value will be set in 0.001- Ω increments if the resistance is less than 10 Ω and 0.01- Ω increments if the resistance is 10 Ω or over.

Note 2. The default setting for this parameter is the standard phase to neutral resistance of the maximum applicable motor.

■ Setting the Motor No-load Current (n110)

- Set the motor no-load current in percentage based on the rated current of the Inverter as 100%.
- Contact the manufacturer of the motor for the motor no-load current.
- This parameter is used as a vector control constant. Be sure to set the parameter correctly. This set value is used for slip compensation as well.

n110	Motor No-load Current	Register	016E Hex	Changes during operation	No
Setting range	0 to 99 (%)	Unit of setting	1%	Default setting	See note

Note The default setting for this parameter is the standard no-load current of the maximum applicable motor.

5-3 Operation in V/f Control

This mode, which is used by conventional general-purpose inverters, is convenient when replacing a conventional model with the 3G3MV Inverter because the Inverter in this mode can be operated without considering the constants of the motor. Furthermore, set the Inverter to this mode if the Inverter is connected to than two or more motors or special motors, such as high-speed motors.

To operate the Inverter in V/f control mode, be sure to set n036 for the rated motor current and n011 through n017 for the V/f pattern.

5-3-1 Setting the Rated Motor Current (n036)

- Check the motor nameplate and set this parameter to the rated current.
- This set value is used for determining the electronic thermal characteristics to protect the motor from overheating. The correct set value protects the motor from burning that may result from overloading.

n036	Rated Motor Current	Register	0124 Hex	Changes during operation	No
Setting range	0.0% to 150% (A) of rated output current of the Inverter	Unit of setting	0.1 A	Default setting	See note 1

Note 1. The default setting for this parameter is the standard rated current of the maximum applicable motor.

Note 2. Motor overload detection (OL1) is disabled by setting the parameter to 0.0.

5-3-2 Setting the V/f Patterns (n011 to n017)

- Set the V/f pattern so that the motor output torque is adjusted to the required load torque.
- The 3G3MV incorporates an automatic torque boost function. Therefore, a maximum of 150% torque can be output at 3 Hz without changing the default settings. Check the system in trial operation and leave the default settings as they are if no torque characteristic changes are required.

n011	Maximum Frequency (FMAX)	Register	010B Hex	Changes during operation	No
Setting range	50.0 to 400.0 (Hz)	Unit of setting	0.1 Hz	Default setting	60.0

n012	Maximum Voltage (VMAX)	Register	010C Hex	Changes during operation	No
Setting range	0.1 to 255.0 [0.1 to 510.0] (V)	Unit of setting	0.1 V	Default setting	200.0 [400.0]
n013	Maximum Voltage Frequency (FA)	Register	010D Hex	Changes during operation	No
Setting range	0.2 to 400.0 (Hz)	Unit of setting	0.1 Hz	Default setting	60.0
n014	Middle Output Frequency (FB)	Register	010E Hex	Changes during operation	No
Setting range	0.1 to 399.9 (Hz)	Unit of setting	0.1 Hz	Default setting	1.5
n015	Middle Output Frequency Voltage (VC)	Register	010F Hex	Changes during operation	No
Setting range	0.1 to 255.0 [0.1 to 510.0] (V)	Unit of setting	0.1 V	Default setting	12.0 [24.0] (seenote2)
n016	Minimum Output Frequency (FMIN)	Register	0110 Hex	Changes during operation	No
Setting range	0.1 to 10.0 (Hz)	Unit of setting	0.1 Hz	Default setting	1.5
n017	Minimum Output Frequency Voltage (VMIN)	Register	0111 Hex	Changes during operation	No
Setting range	0.1 to 50.0 [0.1 to 100.0] (V)	Unit of setting	0.1 V	Default setting	12.0 [24.0] (seenote2)

Note 1. [] values indicate those for 400-V-class Inverters.

Note 2. For 5.5- and 7.5-kW Inverters, this value is set to 10.0 V for 200-V-class models and to 20.0 V for 400-V-class models.

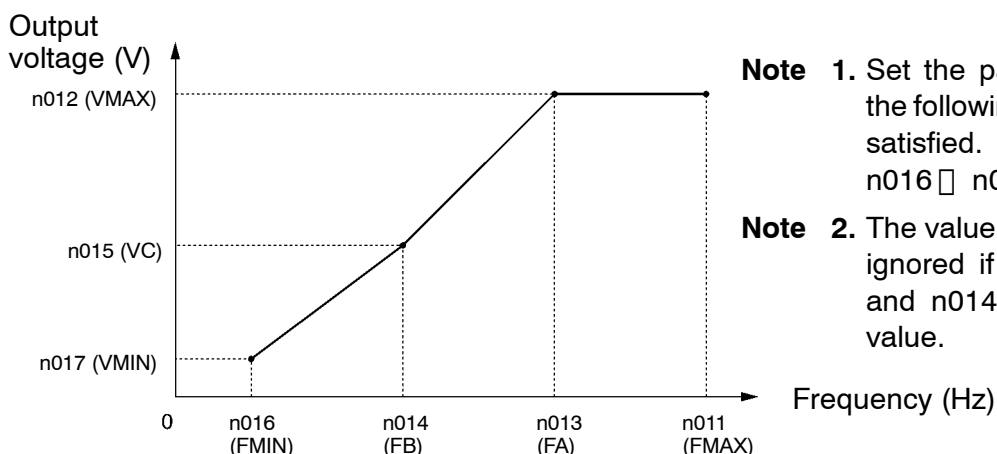

Note 1. Set the parameters so that the following condition will be satisfied.
 $n016 \leq n014 < n013 \leq n011$

Note 2. The value set in n015 will be ignored if parameters n016 and n014 are the same in value.

- Set the rated motor frequency as the maximum voltage frequency, and set the rated motor voltage as the maximum voltage.
- The vertical-axis load or the load with high viscous friction may require high torque at low speed. If the torque is insufficient at low speed, increase the voltage in the low-speed range by 1 V, provided that no overload (OL1 or OL2) is detected. If an overload is detected, decrease the set values or consider the use of an Inverter model with a higher capacity.
- The required torque of fan or pump control increases in proportion to the square of the speed. By setting a quadratic V/f pattern to increase the voltage in the low-speed range, the power consumption of the system will increase.

5-4 Setting the Local/Remote Mode

The 3G3MV operates in local or remote mode. The following description provides information on these modes and how to select them.

■ Basic Concept

Operation mode	Basic concept	Description
Local	The Inverter in a system operates independently in this mode so that the Inverter can be checked independently.	<p>Operation Command Starts with the RUN Key of the Digital Operator and stops with the STOP/RESET Key.</p> <p>Frequency Reference Set with the Digital Operator or the FREQ adjuster. Set with frequency reference selection in local mode in n007.</p>
Remote	The Inverter in a system operates according to the control signal of the host controller.	<p>Operation Command Selectable from four types and set in n003.</p> <p>Frequency Reference Selectable from ten types and set in n004.</p>

■ Local/Remote Selection Methods

- The following two selection methods are available to set the Inverter to local or remote mode. However, it is not possible to switch between local and remote modes during operation command input.
 - Select the mode with the LO/RE Key of the Digital Operator.
 - Set any one of multi-function inputs 1 through 7 (n050 through n056) to 17 to set the Inverter to local mode with control input turned ON.

Note If the above setting is made, mode selection will be possible only with multi-function input, and not with the Digital Operator.

- The inverter always goes into remote mode when the power is turned ON. To operate immediately after power-up, preset the RUN command and frequency reference settings in remote mode.

5-5 Selecting the Operation Command

The following description provides information on how to input operation commands to start or stop the Inverter or change the direction of rotation of the Inverter.

Two types of command input methods are available. Select either one of them according to the application.

■ Selecting the Operation Mode (n003)

- Select the method of operation mode input to start or stop the Inverter.
- The following method is enabled in remote mode only. The command can be input through key sequences on the Digital Operator.

n003	Operation Command Selection	Register	0103 Hex	Changes during operation	No
Setting range	0 to 3	Unit of setting	1	Default setting	0

Set Values

Value	Description
0	The RUN and STOP/RESET Keys of the Digital Operator are enabled.
1	Multi-function input in 2- or 3-wire sequence through the control circuit terminals is enabled.
2	MODBUS RS-422/485 communications are enabled.
3	Input from optional the CompoBus/D Communications Unit is enabled.

■ Selecting the STOP/RESET Key Function (n007)

- When parameter n003 is not set to 0, set whether or not to use the STOP/RESET Key of the Digital Operator to stop the Inverter in remote mode. The STOP/RESET Key is always enabled in local mode regardless of the setting in n003.

n007	STOP Key Function Selection	Register	0107 Hex	Changes during operation	No
Setting range	0, 1	Unit of setting	1	Default setting	0

Set Values

Value	Description
0	The STOP/RESET Key of the Digital Operator is enabled.
1	The STOP/RESET Key of the Digital Operator is disabled.

5-6 Setting the Frequency Reference

5-6-1 Selecting the Frequency Reference

The following description provides information on how to set the frequency reference in the Inverter. Select the method according to the operation mode.

Remote mode: Select and set one out of ten frequency references in n004.

Local mode: Select and set one out of two frequency references in n008.

■ Selecting the Frequency Reference (n004) in Remote Mode

- Select the input method of frequency references in remote mode.
- Ten frequency references are available in remote mode. Select one of them according to the application.

n004	Frequency Reference Selection	Register	0104 Hex	Changes during operation	No
Setting range	0 to 9	Unit of setting	1	Default setting	0

Set Values

Value	Description
0	The settings of the FREQUENCY adjuster in the Digital Operator are enabled. (see note 1)
1	Frequency reference 1 (n024) is enabled.
2	The frequency reference control terminal (for 0- to 10-V input) is enabled. (see note 2)
3	The frequency reference control terminal (for 4- to 20-mA current input) is enabled. (see note 3)
4	The frequency reference control terminal (for 0- to 20-mA current input) is enabled. (see note 3)
5	The pulse train command control input is enabled.
6	Frequency reference (0002 Hex) through MODBUS communications is enabled.
7	Multi-function analog voltage input (0 to 10 V) is enabled. This setting is not required unless two analog inputs are required in PID control.
8	Multi-function analog current input (4 to 20 mA) is enabled. This setting is not required unless two analog inputs are required in PID control.
9	Frequency reference input from the CompoBus/D Communications Unit is enabled.

Note 1. The maximum frequency (FMAX) is set when the FREQ adjuster is set to MAX.

Note 2. The maximum frequency (FMAX) is set with 10 V input.

Note 3. The maximum frequency (FMAX) is set with 20 mA input, provided that SW2 on the control PCB is switched from V to I.

Note 4. Set n149 for the pulse train input scale to the pulse train frequency that is equivalent to the maximum frequency (FMAX).

- The frequency reference set in n004 functions as frequency reference 1 when the Inverter is in multi-step speed operation. The set values in n025 through n031 and n120 through n127 for frequency references 2 through 16 are enabled.

■ Selecting the Frequency Reference (n008) in Local Mode

- Select the input method of frequency references in local mode.
- Two frequency references are available in local mode. Select one of them according to the application.

n008	Frequency Reference Selection in Local Mode	Register	0108 Hex	Changes during operation	No
Setting range	0, 1	Unit of setting	1	Default setting	0

Set Values

Value	Description
0	The settings of the FREQ adjuster in the Digital Operator are enabled. (see note 1)
1	Key sequences on the Digital Operator are enabled. (see note 2)

Note 1. The maximum frequency (FMAX) is set when the FREQ adjuster is set to MAX.

Note 2. The frequency reference can be set with key sequences while the FREF indicator is lit or with the set value in n024 for frequency reference 1. In either case, the value is set in n024.

5-6-2 Upper and Lower Frequency Reference Limits

Regardless of the methods of operation mode and frequency reference input, the upper and lower frequency reference limits can be set.

■ Setting the Upper and Lower Frequency Reference Limits (n033 and n034)

- Set the upper and lower frequency reference limits as percentage based on the maximum frequency as 100%.

n033	Upper Frequency Reference Limit	Register	0121 Hex	Changes during operation	No
Setting range	0% to 110% (Max. frequency = 100%)	Unit of setting	1%	Default setting	100
n034	Lower Frequency Reference Limit	Register	0122 Hex	Changes during operation	No
Setting range	0% to 110% (Max. frequency = 100%)	Unit of setting	1%	Default setting	0

Note If n034 is set to a value less than the minimum output frequency (FMIN), the Inverter will have no output when a frequency reference less than the minimum output frequency input is ON.

5-6-3 Frequency Referencing by Analog Input

This section explains the methods for referencing frequencies by analog input, adjusting input characteristics, and detecting input command errors. Either the frequency reference control terminal (voltage/current) or multi-function analog voltage/current input can be used for analog inputs. The gain, bias, and filter time parameters can be used for adjustments, or, alternatively, the adjustments can be made by external analog voltage (current), using the multi-function analog inputs.

■ Setting Frequency References by Analog Input

- Analog inputs can be set only in remote mode. Set parameter n004 (frequency reference selection) to any of the following: 2 to 4 (frequency reference control terminal), 7 (multi-function analog voltage input), or 8 (multi-function analog current input).

Note If the frequency reference control terminal is to be used for current inputs, the SW2 setting must be changed from V to I. Please also refer to page 2-17.

■ FR Terminal Adjustments for Frequency Reference Input

● Gain and Bias Settings (n060 and n061)

- Set the input characteristics of analog frequency references in n060 (for the frequency reference gain) and n061 (for the frequency reference bias).
- Set the frequency of maximum analog input (10 V or 20 mA) in n41 as percentage based on the maximum frequency as 100%.

Example: In order to obtain the maximum frequency at 5 V, set the value to 200% because 10-V input is 200% maximum frequency.

- Set the frequency of minimum analog input (0 V, 0 mA, or 4 mA) in n42 as percentage based on the maximum frequency as 100%.

Example: In order to obtain 50% maximum frequency output with 0 V input, set the value to 50%.

n060	Frequency Reference Gain	Register	013C Hex	Changes during operation	Yes
Setting range	0% to 255% (Max. frequency = 100%)	Unit of setting	1%	Default setting	100

n061	Frequency Reference Bias	Register	013D Hex	Changes during operation	Yes
Setting range	-99% to 99% (Max. frequency = 100%)	Unit of setting	1%	Default setting	0

● **Filter Time Constant Settings (n062)**

- A primary delay digital filter can be set for analog frequency references to be input.
- This setting is ideal if the analog input signal changes rapidly or the signal is subject to noise interference.
- The larger the set value is, the slower the response speed will be.

n062	Analog Frequency Reference Filter Time	Register	013E Hex	Changes during operation	No
Setting range	0.00 to 2.00 (s)	Unit of setting	0.01 s	Default setting	0.10

■ **Multi-function Analog Input**

An auxiliary analog input can be set for the Digital Operator’s multi-function analog voltage/current input. Select from the following functions.

n077	Multi-function Analog Input Terminal Function Selection	Register	014D Hex	Changes during operation	No
Setting range	0 to 4	Unit of setting	1	Default setting	0

n078	Multi-function Analog Input Terminal Selection	Register	014E Hex	Changes during operation	No
Setting range	0, 1	Unit of setting	1	Default setting	0

n079	Multi-function Analog Input Frequency Bias	Register	014F Hex	Changes during operation	No
Setting range	0 to 50	Unit of setting	1 %	Default setting	10

Note Please also refer to page 2-20.

- For n077, select from the following five functions allocated to the multi-function analog input terminal.

n077 Set Values

Value	Name	Description
0	Multi-function Analog Input Function Disable	Disables multi-function analog inputs. Set “0” when setting multi-function inputs with n004 (Frequency Reference Selection) or n164 (PID Feedback Input Block Selection). If this function is allocated for both, an error (err or oP6) will be generated.
1	Auxiliary Frequency Reference	Sets the terminal to be used as a second analog frequency reference terminal. The analog input from the multi-function analog input becomes the frequency reference in place of Frequency Reference 2. Toggle the two analog inputs with the multi-function input’s multi-step speed references. When this function is set, Frequency Reference 2 (n025) is ignored.
2	Frequency Gain (See note 1.)	Adjusts the gain for frequency references that are input to the frequency reference input (analog) terminal. 0 to 10 V (4 mA, or 0 mA to 20 mA): 0x to 2x (See note 2.)
3	Frequency Bias (See note 1.)	Adjusts the bias for frequency references that are input to the frequency reference input (analog) terminal. 0 to 10 V (4 mA, or 0 mA to 20 mA): -n079 SV to +n079 SV (See note 2.)
4	Output Voltage Bias	Adjusts the Inverter’s output voltage bias. The bias value that is input is added to the output voltage value for the normal V/f setting. 0 to 10 V (4 mA, or 0 mA to 20 mA): 0 V to +100 V (See note 2.)

Note 1. The frequency reference gain (n060) and frequency reference bias (n061) parameter settings are enabled. If “frequency gain” is set for the multi-function analog input, it is multiplied by n060; if “frequency bias” is set, it is added to n061.

Note 2. The relationship between the multi-function analog input’s input voltage and control variable is shown for when the frequency reference and multi-function analog input gain are 100%, and when the bias setting is 0%.

- For n078, select whether select whether voltage inputs or current inputs are to be used.

Value	Description
0	Enable multi-function analog voltage inputs. (Disable current inputs.)
1	Enable multi-function analog current inputs. (Disable voltage inputs.)

- When setting “3” (frequency bias) for the multi-function analog input terminal function selection (n077), set the standard value for the bias in n079. Make the setting as a percentage, with the maximum frequency (n011) as 100%.

■ Adjusting Multi-function Analog Input

● Setting the Gain and Bias of Multi-function Analog Voltage/Current Input (n068 to n072)

- Set the multi-function analog voltage input characteristics in n068 (multi-function analog voltage input gain) and n069 (multi-function analog voltage input bias). Set the multi-function analog current input characteristics in n071 (multi-function analog current input gain) and n072 (multi-function analog current input bias).
- For the gain, set the maximum analog input (10 V or 20 mA) frequency as a percentage with the maximum frequency as 100%.
- For the bias, set the minimum analog input (0 V or 4 mA) frequency as a percentage with the maximum frequency as 100%.

n068	Multi-function Analog Voltage Input Gain	Register	0144 Hex	Changes during operation	Yes
Setting range	-255(%) to 255(%) (Max. frequency: 100%)	Unit of setting	1%	Default setting	100

n069	Multi-function Analog Voltage Input Bias	Register	0145 Hex	Changes during operation	Yes
Setting range	-100(%) to 100(%) (Max. frequency: 100%)	Unit of setting	1%	Default setting	0

n071	Multi-function Analog Current Input Gain	Register	0147 Hex	Changes during operation	Yes
Setting range	-255(%) to 255(%) (Max. frequency: 100%)	Unit of setting	1%	Default setting	100

n072	Multi-function Analog Current Input Bias	Register	0148 Hex	Changes during operation	Yes
Setting range	-100(%) to 100(%) (Max. frequency: 100%)	Unit of setting	1%	Default setting	0

● Setting the Filter Time Constant of Multi-function Analog Voltage/Current Input (n070 and n073)

- These parameters can be used to set a primary-delay digital filter for multi-function analog voltage input. For voltage inputs, set the multi-function analog voltage input filter time constant (n070). For current inputs, set the multi-function analog current input filter time constant (n073).

- These parameter settings are effective for smooth operation of the Inverter if the analog input signal changes too rapidly or the signal is interfered with by noise.
- The larger the set value is, the slower the response will be.

n070	Multi-function Analog Voltage Input Filter Time Constant	Register	0146 Hex	Changes during operation	Yes
Setting range	0.00 to 2.00 (s)	Unit of setting	0.01 s	Default setting	0.10

n073	Multi-function Analog Current Input Filter Time Constant	Register	0149 Hex	Changes during operation	Yes
Setting range	0.00 to 2.00 (s)	Unit of setting	0.01 s	Default setting	0.10

■ **Frequency Reference Loss Detection (n064)**

This function is provided for 5.5- and 7.5-kW Inverters only. If the frequency reference from the control circuit drops by more than 90% within 400 ms, this function detects it and determines that the reference has been lost (e.g., from some cause such as disconnected wiring).

- When operating in remote mode, the setting for the frequency reference loss detection function is enabled when either an analog reference or a pulse train reference is selected for n004 (frequency reference selection).

Note 1. If “frequency reference agree” (set value: 2) is preset for multi-function outputs 1 to 3 (n057 to n059), the frequency reference loss status can be checked. When using this output, implement external error processing.

Note 2. When the frequency reference loss detection is enabled and a loss is detected, operation will continue at 80% of the frequency reference prior to the loss.

Note 3. If the frequency reference is restored during a frequency reference loss, and the frequency returned to at least the level of the continuing operation, the frequency reference loss detection will be cleared and the Inverter will return to normal operation.

Note 4. Frequency reference loss detection does not operate for multi-function analog inputs.

n064	Frequency Reference Loss Detection	Register	Changes during operation	0140 Hex	No
Setting range	0, 1	Unit of setting	1	Default setting	0

Value	Description
0	Loss detection disabled. (Operation according to frequency reference; frequency reference loss detection disabled.)
1	Loss detection enabled. (After loss detection, operation continues at 80% of the frequency reference prior to the loss; frequency reference loss detection enabled.)

5-6-4 Setting Frequency References through Key Sequences

The following description provides information on parameters related to frequency reference settings through key sequences on the Digital Operator

■ Frequency Reference Setting/Decimal Place Selection (n035)

- Set the unit of frequency reference and frequency-related values to be set or monitored in n035 through the Digital Operator.
- The frequency reference value will be set in 0.01-Hz increments if the frequency is less than 100 Hz and 0.1-Hz increments if the frequency is 100 Hz or over.

n035	Frequency Reference Setting/ Decimal Place Selection	Register	0123 Hex	Changes during operation	No
Setting range	0 to 3,999	Unit of setting	1	Default setting	0

Set Values

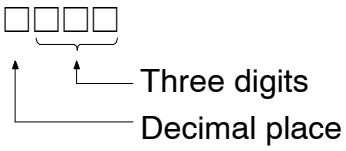
Value	Description
0	Less than 100 Hz: 0.01-Hz increments 100 Hz or over: 0.1-Hz increments
1	0.1% increments (Max. frequency: 100%)
2 to 39	1-rpm increments (number of motor poles)
40 to 3,999	Unit setting The value to be set or monitored at max. frequency  <p>Note To display 50.0 for example, set the value to 1500. (see note)</p>

Note The unit of setting of each parameter and monitor item below varies with the decimal place.

Parameters

n024 to n032: Frequency references 1 through 8 and inching frequency command
n120 through n127: Frequency references 9 through 16

Monitor Items

U-01: Frequency reference monitor
U-02: Output frequency monitor

■ Setting Frequency References 1 through 16 and the Inching Frequency Command (n024 through n031, n120 through n127)

Frequency references 1 through 16 and an inching frequency command can be set together in the Inverter (using registers n024 through n31, n120 through n127).

● Setting Frequency References 1 through 16 (n024 through n31, n120 through n127)

n024	Frequency Reference 1	Register	0118 Hex	Changes during operation	Yes
Setting range	0.00 to max. frequency	Unit of setting	0.01 Hz (see note 1)	Default setting	6.0

n025	Frequency Reference 2	Register	0119 Hex	Changes during operation	Yes
Setting range	0.00 to max. frequency	Unit of setting	0.01 Hz (see note 1)	Default setting	0.00

n026	Frequency Reference 3	Register	011A Hex	Changes during operation	Yes
Setting range	0.00 to max. frequency	Unit of setting	0.01 Hz (see note 1)	Default setting	0.00

n027	Frequency Reference 4	Register	011B Hex	Changes during operation	Yes
Setting range	0.00 to max. frequency	Unit of setting	0.01 Hz (see note 1)	Default setting	0.00

n028	Frequency Reference 5	Register	011C Hex	Changes during operation	Yes
Setting range	0.00 to max. frequency	Unit of setting	0.01 Hz (see note 1)	Default setting	0.00

n029	Frequency Reference 6	Register	011D Hex	Changes during operation	Yes
Setting range	0.00 to max. frequency	Unit of setting	0.01 Hz (see note 1)	Default setting	0.00

n030	Frequency Reference 7	Register	011E Hex	Changes during operation	Yes
Setting range	0.00 to max. frequency	Unit of setting	0.01 Hz (see note 1)	Default setting	0.00
n031	Frequency Reference 8	Register	011F Hex	Changes during operation	Yes
Setting range	0.00 to max. frequency	Unit of setting	0.01 Hz (see note 1)	Default setting	0.00
n120	Frequency Reference 9	Register	0178 Hex	Changes during operation	Yes
Setting range	0.00 to max. frequency	Unit of setting	0.01 Hz (see note 1)	Default setting	0.00
n121	Frequency Reference 10	Register	0179 Hex	Changes during operation	Yes
Setting range	0.00 to max. frequency	Unit of setting	0.01 Hz (see note 1)	Default setting	0.00
n122	Frequency Reference 11	Register	017A Hex	Changes during operation	Yes
Setting range	0.00 to max. frequency	Unit of setting	0.01 Hz (see note 1)	Default setting	0.00
n123	Frequency Reference 12	Register	017B Hex	Changes during operation	Yes
Setting range	0.00 to max. frequency	Unit of setting	0.01 Hz (see note 1)	Default setting	0.00
n124	Frequency Reference 13	Register	017C Hex	Changes during operation	Yes
Setting range	0.00 to max. frequency	Unit of setting	0.01 Hz (see note 1)	Default setting	0.00
n125	Frequency Reference 14	Register	017D Hex	Changes during operation	Yes
Setting range	0.00 to max. frequency	Unit of setting	0.01 Hz (see note 1)	Default setting	0.00

n126	Frequency Reference 15	Register	017E Hex	Changes during operation	Yes
Setting range	0.00 to max. frequency	Unit of setting	0.01 Hz (see note 1)	Default setting	0.00

n127	Frequency Reference 16	Register	017F Hex	Changes during operation	Yes
Setting range	0.00 to max. frequency	Unit of setting	0.01 Hz (see note 1)	Default setting	0.00

Note 1. The setting unit of frequency references 1 through 16 is changed with the set value in n035 for frequency reference setting and decimal place selection. Values will be set in 0.01-Hz increments if the frequency is less than 100 Hz and 0.1-Hz increments if the frequency is 100 Hz or over.

Note 2. Frequency reference 1 is enabled with n004 for frequency reference selection set to 1.

Note 3. Frequency references 2 through 16 are enabled by setting multi-step speed references 1 through 4 in n050 through n056 for multi-function input. Refer to the following table for the relationship between multi-step speed references 1 through 4 and frequency references 1 through 16.

Frequency reference	Multi-step speed reference 1 (Set value: 6)	Multi-step speed reference 2 (Set value: 7)	Multi-step speed reference 3 (Set value: 8)	Multi-step speed reference 4 (Set value: 9)
Frequency reference 1	OFF	OFF	OFF	OFF
Frequency reference 2	ON	OFF	OFF	OFF
Frequency reference 3	OFF	ON	OFF	OFF
Frequency reference 4	ON	ON	OFF	OFF
Frequency reference 5	OFF	OFF	ON	OFF
Frequency reference 6	ON	OFF	ON	OFF
Frequency reference 7	OFF	ON	ON	OFF
Frequency reference 8	ON	ON	ON	OFF
Frequency reference 9	OFF	OFF	OFF	ON
Frequency reference 10	ON	OFF	OFF	ON
Frequency reference 11	OFF	ON	OFF	ON
Frequency reference 12	ON	ON	OFF	ON
Frequency reference 13	OFF	OFF	ON	ON
Frequency reference 14	ON	OFF	ON	ON
Frequency reference 15	OFF	ON	ON	ON
Frequency reference 16	ON	ON	ON	ON

To change the frequency of frequency reference 2, for example, turn ON only the multi-function input terminal where multi-step speed reference 2 is set, and turn OFF any other multi-function input terminal.

For example, no settings for multi-step speed reference 3 or 4 will be required if only frequency references 1 through 4 are used. Any multi-step speed reference not set is regarded as turned-OFF input.

● Setting the Inching Frequency Command (n032)

- The inching frequency command must be set as multi-function input in order to use the inching frequency command.

n032	Inching Frequency Command	Register	0120 Hex	Changes during operation	Yes
Setting range	0.00 to max. frequency	Unit of setting	0.01 Hz (see note 1)	Default setting	6.0

Note 1. The setting unit of the inching frequency command is changed with the set value in n035 for frequency reference setting and decimal place selection. The value will be set in 0.01-Hz increments if the frequency is less than 100 Hz and 0.1-Hz increments if the frequency is 100 Hz or over.

Note 2. In order to use the inching frequency command, one of the n050 through n056 parameters for multi-function digital input must be set to 10 as an inching frequency command. Parameter n032 is selectable by turning ON the multi-function input set with the inching frequency command. The inching frequency command takes preference over the multi-step speed reference (i.e., when the inching frequency command is ON, all multi-step speed reference input will be ignored).

■ Setting the Frequency Reference with the FREF Indicator Lit

- The frequency reference can be set while the FREF indicator of the Digital Operator is lit in the following cases.
 - Parameter n004 for frequency reference selection is set to 1, which enables frequency reference 1, and the Inverter is in remote mode.
 - Parameter n008 for frequency selection in local mode is set to 1, which enables key sequences on the Digital Operator, and the Inverter is in local mode.
 - Frequency references 2 through 16 are set with multi-step speed reference input.
- The frequency reference can be changed, even during operation.

- When the frequency reference is changed while the FREF indicator is lit, the corresponding parameter is changed simultaneously. For example, if frequency reference 2 has been selected with multi-function input (a multi-step speed reference), the set value in n025 (for frequency reference 2) will be changed simultaneously when the frequency reference is changed while the FREF indicator is lit.
- Take the following default steps, for example, to change the frequency reference with the FREF indicator lit.



Key sequence	Indicator	Display example	Explanation
	FREF	6.00	Power On Note If the FREF indicator has not been lit, press the Mode Key repeatedly until the FREF indicator is lit.
▲ ▼	FREF	60.00 ~~~~~	Use the Increment or Decrement Key to set the frequency reference. The data display will flash while the frequency reference is set.
↵	FREF	60.00	Press the Enter Key so that the set value will be entered and the data display will be lit.

● **Setting the Key Sequential Frequency (n009)**

- The Enter Key need not be pressed when changing the setting in n009. In that case, the frequency reference will change when the set value is changed with the Increment or Decrement Key while the data display is continuously lit.

n009	Key Sequential Frequency Setting	Register	0109 Hex	Changes during operation	No
Setting range	0, 1	Unit of setting	1	Default setting	0

Set Values

Value	Description
0	Enter Key enabled (The set value is entered with the Enter Key pressed.)
1	Enter Key disabled (The set value set is entered immediately.)

5-6-5 Setting Frequency References by Pulse Train Input

By setting n004 for frequency reference selection to 5 for enabling the pulse train reference control terminal, frequency references can be executed by pulse train input through the PR terminal.

The following description provides information on the n149 parameter (pulse train input scale), which is used to execute frequency references by pulse train input.

■ Setting the Pulse Train Input Scale (n149)

- Set this parameter to the pulse train input scale so that frequency references can be executed by pulse train input.
- Set the maximum pulse train frequency in 10-Hz increments based on 10 Hz as 1. A proportional relationship is applied to frequencies less than the maximum frequency.

n149	Pulse Train Input Scale	Register	0195 Hex	Changes during operation	No
Setting range	100 to 3,300	Unit of setting	1 (10 Hz)	Default setting	2,500

Note 1. For example, to set the maximum frequency reference with pulse train frequency input at 10 kHz, set the parameter to 1000 from the following formula.
 $10,000 \text{ (Hz)} / 10 \text{ (Hz)} = 1,000$

Note 2. Input the pulse train into the frequency reference common (FC) and pulse train input (RP) terminals under the following conditions.

High level: 3.5 to 13.2 V

Low level: 0.8 V max.

The response frequency is within a range from 0 to 33 kHz (30% to 70% ED).
 ED = Operating Duty Cycle.

■ Setting the Pulse Train Frequency Reference Gain/Bias (n074/n075)

- Set the input characteristics of pulse train input.
- Gain: Set the gain in percentage based on the maximum frequency of the pulse train input scale in n149 as 100%.
- Bias: Set the bias in percentage for frequency reference input at 0-Hz pulse train input based on the maximum frequency as 100%.

n074	Pulse Train Frequency Reference Gain	Register	014A Hex	Changes during operation	Yes
Setting range	-255 to 255	Unit of setting	1%	Default setting	100
n075	Pulse Train Frequency Reference Bias	Register	014B Hex	Changes during operation	Yes
Setting range	-100 to 100	Unit of setting	1%	Default setting	0

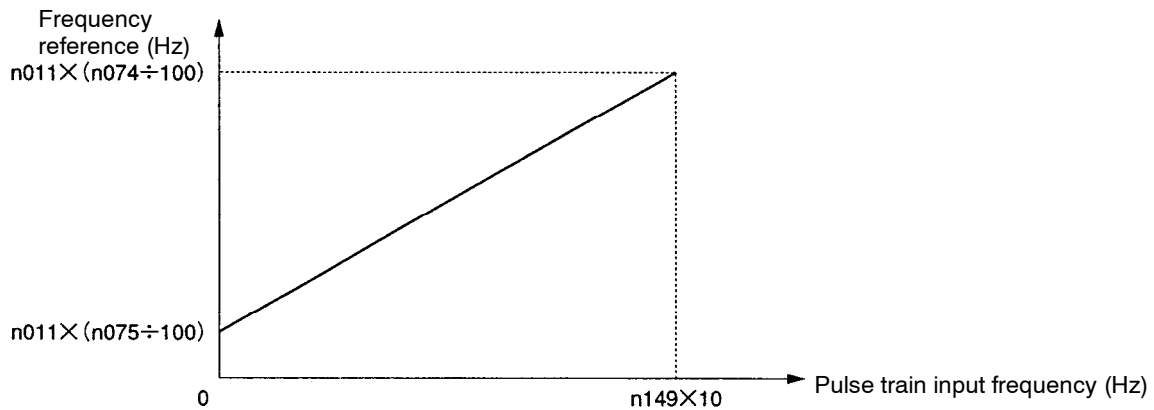

n011: Maximum frequency

■ **Pulse Train Frequency Reference Input Filter Constant (n076)**

- This parameter can be used to set a primary-delay digital filter for pulse train frequency reference input.
- This parameter setting is effective for smooth operation of the Inverter if the pulse train input signal changes too rapidly or the signal is interfered with by noise.
- The larger the set value is, the lower the response will be.

n076	Pulse Train Frequency Reference Input Filter Constant	Register	014C Hex	Changes during operation	No
Setting range	0.00 to 2.00	Unit of setting	0.01 s	Default setting	0.10

5-7 Setting the Acceleration/Deceleration Time

The following description provides information on parameters related to acceleration and deceleration time settings.

Trapezoidal and S-shape acceleration and deceleration are available. Using the S-shape characteristic function for acceleration and deceleration can reduce shock to the machinery when stopping or starting.

■ Acceleration/Deceleration Time Unit (n018)

- The acceleration and deceleration time of the Inverter can be set within a range from 0.0 to 6,000 s without changing the default setting. If a more precise unit of setting is required, this parameter can be set for 0.01-s increments. In this case, the setting range will be from 0.00 to 600.0 s.

n018	Acceleration/Deceleration Time Setting	Register	0112 Hex	Changes during operation	No
Setting range	0, 1	Unit of setting	1	Default setting	0

Set Values

Value	Description
0	Less than 1,000 s: 0.1-s increments 1,000 s or over: 1-s increments
1	Less than 100 s: 0.01-s increments 100 s or over: 0.1-s increments

■ Setting the Acceleration/Deceleration Time (n019 through n022)

- Two acceleration times and two deceleration times can be set.
- The acceleration time is the time required to go from 0% to 100% of the maximum frequency and the deceleration time is the time required to go from 100% to 0% of the maximum frequency. The actual acceleration or deceleration time is obtained from the following formula.

$$\text{Acceleration/Deceleration time} = (\text{Acceleration/Deceleration time set value}) \times (\text{Frequency reference value}) \div (\text{Max. frequency})$$

Acceleration time 2 and deceleration time 2 are enabled by setting 11 for acceleration/deceleration time selection in any of the n050 through n056 parameters for multi-function input.

Deceleration time 2 is also enabled by emergency-stop settings 19, 20, 21, and 22 in any of the parameters for parameters n050 through n056 for multi-function input with n005 for interruption mode selection set to 0 (i.e., deceleration stop).

n019	Acceleration Time 1	Register	0113 Hex	Changes during operation	Yes
Setting range	0.0 to 6,000 (s) (see note 1)	Unit of setting	0.1 s (see note 1)	Default setting	10.0

n020	Deceleration Time 1	Register	0114 Hex	Changes during operation	Yes
Setting range	0.0 to 6,000 (s) (see note 1)	Unit of setting	0.1 s (see note 1)	Default setting	10.0

n021	Acceleration Time 2	Register	0115 Hex	Changes during operation	Yes
Setting range	0.0 to 6,000 (s) (see note 1)	Unit of setting	0.1 s (see note 1)	Default setting	10.0

n022	Deceleration Time 2	Register	0116 Hex	Changes during operation	Yes
Setting range	0.0 to 6,000 (s) (see note 1)	Unit of setting	0.1 s (see note 1)	Default setting	10.0

Note 1. The setting unit of acceleration or deceleration time is determined by the set value in n018 (acceleration/deceleration time unit).

n018 set to 0: Setting range from 0.0 to 6,000 (0.0 through 999.9 s or 1,000 through 6,000 s)

n018 set to 1: Setting range from 0.00 to 600.0 (0.0 through 99.99 s or 100.0 through 600.0 s)

Note 2. When n018 is set to 1, the default value of acceleration or deceleration time will be set to 10.00.

■ S-shape Acceleration/Deceleration Characteristic (n023)

- Trapezoidal and S-shape acceleration and deceleration are available. Using the S-shape characteristic function for acceleration and deceleration can reduce shock to the machinery when stopping or starting.
- Any one of three S-shape acceleration/deceleration times (0.2, 0.5, and 1.0 s) is selectable.

n023	S-shape Acceleration/Deceleration Characteristic	Register	0117 Hex	Changes during operation	No
Setting range	0 to 3	Unit of setting	1	Default setting	0

Set Values

Value	Description
0	No S-shape acceleration/deceleration characteristic (Trapezoidal acceleration/deceleration)
1	S-shape acceleration/deceleration characteristic time is 0.2 s
2	S-shape acceleration/deceleration characteristic time is 0.5 s
3	S-shape acceleration/deceleration characteristic time is 1.0 s

Note When the S-shape acceleration/deceleration characteristic time is set, the acceleration and deceleration times will be lengthened according to the S-shape at the beginning and end of acceleration/deceleration.

5-8 Selecting the Reverse Rotation-prohibit

This parameter is used to specify whether to enable or disable the reverse rotation command sent to the Inverter from the control circuit terminals or Digital Operator.

The parameter should be set to “not accept” when the Inverter is applied to systems that prohibit the reverse rotation of the Inverter.

■ Selecting the Reverse Rotation-prohibit (n006)

n006	Reverse Rotation-prohibit Selection	Register	0106 Hex	Changes during operation	No
Setting range	0, 1	Unit of setting	1	Default setting	0

Set Values

Value	Description
0	Accept
1	Not accept

5-9 Selecting the Stopping Mode

This parameter is used to specify the stopping mode when the STOP command is input.

The Inverter either decelerates or coasts to a stop according to the stopping mode selection.

■ Selecting the Stopping Mode (n005)

n005	Stopping Mode Selection	Register	0105 Hex	Changes during operation	No
Setting range	0, 1	Unit of setting	1	Default setting	0

Set Values

Value	Description
0	Frequency deceleration stop (see note)
1	Free running

Note The Inverter will decelerate to stop according to the setting in n020 for deceleration time 1 if any of the n050 through n056 parameters for multi-function input is not set to 11 for acceleration/deceleration time selection. If any one of the n050 through n056 multi-function input parameters is set to acceleration/deceleration time selection, the Inverter will decelerate to stop according to the selected setting of deceleration time when the STOP command is input.

5-10 Multi-function I/O

5-10-1 Multi-function Input

The 3G3MV incorporates seven multi-function input terminals (S1 through S7). Inputs into these terminals have a variety of functions according to the application.

■ Multi-function digital Input (n050 through n056)

n050	Multi-function digital Input 1 (S1)	Register	0132 Hex	Changes during operation	No
Setting range	1 to 25 (for 26, see note)	Unit of setting	1	Default setting	1
n051	Multi-function digital Input 2 (S2)	Register	0133 Hex	Changes during operation	No
Setting range	1 to 25 (for 26, see note)	Unit of setting	1	Default setting	2
n052	Multi-function digital Input 3 (S3)	Register	0134 Hex	Changes during operation	No
Setting range	0 to 25 (for 26, see note)	Unit of setting	1	Default setting	3
n053	Multi-function digital Input 4 (S4)	Register	0135 Hex	Changes during operation	No
Setting range	1 to 25 (for 26, see note)	Unit of setting	1	Default setting	5
n054	Multi-function digital Input 5 (S5)	Register	0136 Hex	Changes during operation	No
Setting range	1 to 25 (for 26, see note)	Unit of setting	1	Default setting	6
n055	Multi-function digital Input 6 (S6)	Register	0137 Hex	Changes during operation	No
Setting range	1 to 25 (for 26, see note)	Unit of setting	1	Default setting	7
n056	Multi-function digital Input 7 (S7)	Register	0138 Hex	Changes during operation	No
Setting range	1 to 25, 34, and 35 (for 26, see note)	Unit of setting	1	Default setting	10

Note Set value 26 is available for 5.5kW and 7.5kW Inverters only.

Set Values

Value	Function	Description
0	Forward/Reverse rotation command	3-wire sequence (to be set in n052 only) By setting n052 to 0, the set values in n050 and n051 are ignored and the following settings are forcibly made. S1: RUN input (RUN when ON) S2: STOP input (STOP when OFF) S3: Forward/Reverse rotation command (OFF: Forward; ON: Reverse)
1	Forward/Stop	Forward rotation command in 2-wire sequence
2	Reverse/Stop	Reverse rotation command (2-wire sequence)
3	External fault (NO)	ON: External fault (EF□ detection: □ is a terminal number)
4	External fault (NC)	OFF: External fault (EF□ detection: □ is a terminal number)
5	Fault reset	ON: Fault reset (disabled while RUN command is input)
6	Multi-step speed reference 1	Signals to select frequency references 2 through 16. Note Refer to 5-6-4 <i>Setting the Frequency References through Key Sequences</i> for the relationship between multi-step speed references 1 through 4 and frequency references 1 through 16. Note Any multi-step speed reference not set is regarded as turned-OFF input.
7	Multi-step speed reference 2	
8	Multi-step speed reference 3	
9	Multi-step speed reference 4	
10	Inching frequency command	ON: Inching frequency command (taking preference over the multi-step speed reference)
11	Acceleration/Deceleration time selection	ON: Acceleration time 2 and deceleration time 2 are selected.
12	External base block command (NO)	ON: Output turned OFF (while motor coasting to a stop and "bb" flashing)
13	External base block command (NC)	OFF: Output turned OFF (with motor free running and "bb" flashing)
14	Search command (Searching starts from maximum frequency)	ON: Speed search (Searching starts from n011)
15	Search command (Searching starts from preset frequency)	ON: Speed search

Value	Function	Description
16	Acceleration/Deceleration-prohibit command	ON: Acceleration/Deceleration is on hold (running at parameter frequency)
17	Local or remote selection	ON: Local mode (operated with the Digital Operator) Note After this setting is made, mode selection with the Digital Operator is not possible.
18	Communications/Remote selection	ON: RS422/485 Communications input is enabled. Communications RUN command (0001 Hex) is enabled together with frequency reference (0002 Hex).
19	Emergency stop fault (NO)	<p>The Inverter stops according to the setting in n005 for interruption mode selection with the emergency stop input turned ON.</p> <p>n005 set to 0: Decelerates to stop at deceleration time 2 set in n022. n005 set to 1: Coasts to a stop.</p> <p>Note NO: Emergency stop with the digital input closed. NC: Emergency stop with the digital input opened.</p> <p>Note Fault: Fault output is ON and reset with RESET input. Alarm: Alarm output is ON and automatically restored when emergency stop input is cleared (no reset required).</p> <p>Note "STP" is displayed (lit with fault input ON and flashes with alarm input ON)</p>
20	Emergency stop alarm (NC)	
21	Emergency stop fault (NO)	
22	Emergency stop alarm (NC)	
23	PID control cancel	ON: PID control is disabled. PID control set is disabled and the Inverter is in normal operation according to the n003 and n004 settings.
24	PID control integral reset	ON: Integral value is reset (cleared). The integral value as a result of PID operation is cleared when the Inverter is in PID control. The input status of the Inverter continues with the integral function disabled.
25	PID control integral hold	ON: Integral value is kept on hold (fixed). The integral value as a result of PID operation is kept on hold with only the integral operation function disabled when the Inverter is in PID control.
26 (See note.)	Inverter overheating warning oH3	ON: oH3 display (at the Operator); Inverter overheating warning output ON (multi-function output). Operation continues during input. When the input turns OFF, the Operator display and multi-function output are cleared. Use for functions such as displaying the status of external thermal relays.

Note Set value 26 is available for 5.5- and 7.5-kW Inverters only.

Value	Function	Description															
34	Up or down command	<p>Up or down command (set in n056 only)</p> <p>By setting n056 to 34, the set value in n055 is ignored and the following settings are forcibly made.</p> <p>S6: Up command S7: Down command</p> <table border="1"> <thead> <tr> <th></th> <th>Acceleration</th> <th>Deceleration</th> <th>Hold</th> <th>Hold</th> </tr> </thead> <tbody> <tr> <td>S6 terminal (Up command)</td> <td>ON</td> <td>OFF</td> <td>OFF</td> <td>ON</td> </tr> <tr> <td>S7 terminal (Down command)</td> <td>OFF</td> <td>ON</td> <td>OFF</td> <td>ON</td> </tr> </tbody> </table> <p>Note It is impossible to set the up or down command and multi-step speed references 1 through 4 together.</p> <p>Note To keep the frequency reference that has been adjusted with the Up or Down command after the Inverter is turned OFF, set n100 (Up/Down frequency memory) to 1.</p>		Acceleration	Deceleration	Hold	Hold	S6 terminal (Up command)	ON	OFF	OFF	ON	S7 terminal (Down command)	OFF	ON	OFF	ON
	Acceleration	Deceleration	Hold	Hold													
S6 terminal (Up command)	ON	OFF	OFF	ON													
S7 terminal (Down command)	OFF	ON	OFF	ON													
35	Self-diagnostic test	<p>ON: RS-422/485 communications self-diagnostic test (set in n056 only)</p> <p>The communications function is tested by connecting the transmission and reception terminals together and checking that the data received is the same as the transmission data.</p>															

■ Operation in 2-wire Sequence (Set Value: 1, 2)

- The Inverter operates in 2-wire sequence by setting a multi-function input selection to 1 (forward/reverse) or 2 (reverse/stop).
- The following diagram shows a wiring example of the terminals in 2-wire sequence.

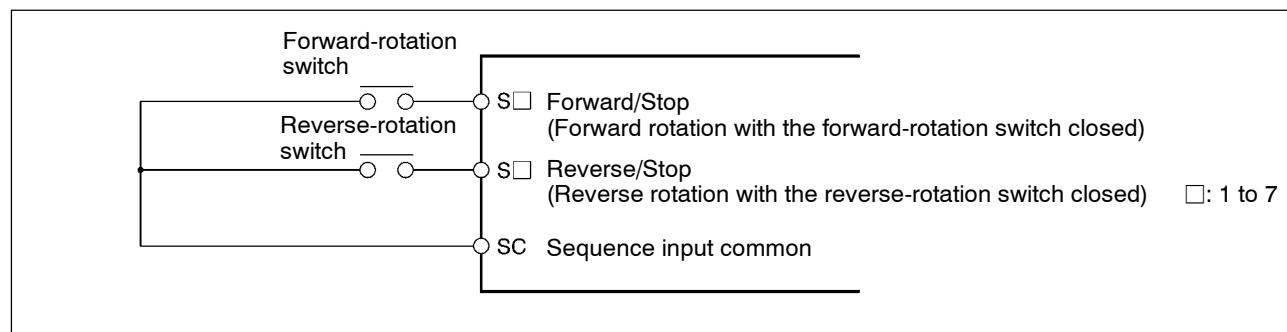

■ Operation in 3-wire Sequence (n052 = 0)

- The Inverter operates in 3-wire sequence by setting n052 for multi-function digital input 3 to 0.
- Only n052 can be set to 0 (3-wire sequence). By making this setting, the set values in n050 and n051 are ignored and the following settings are forcibly made.

S1: RUN input (RUN when ON)

S2: STOP input (STOP when OFF)

S3: Forward/Reverse rotation command (OFF: Forward; ON: Reverse)

- The following diagram shows a wiring example of the terminals in 3-wire sequence.

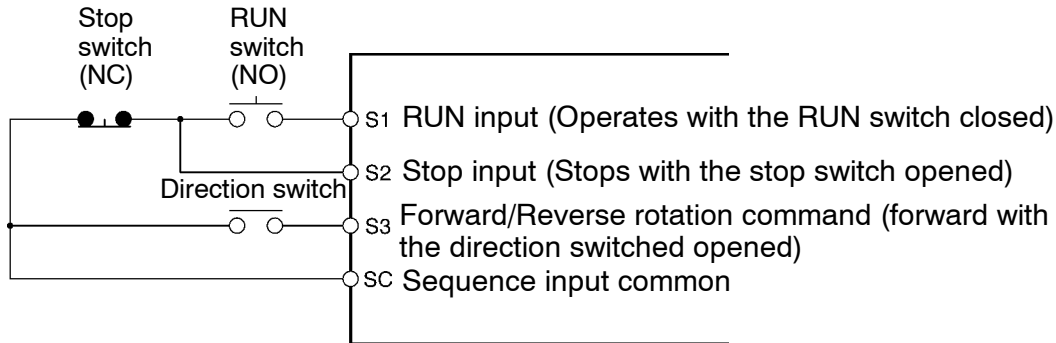

■ External Base Block Command (Set Value: 12, 13)

When an SPST-NO (set value: 12) or SPST-NC (set value: 13) input is received, Inverter outputs are shut OFF. Use these inputs in the following cases to stop Inverter outputs.

- For switching the motor to free running status when applying an external brake.
- For stopping Inverter outputs before disconnecting motor wiring when changing the motor from an Inverter to a commercial power supply.

Note The external base block only shuts Off the Inverter’s output frequency, and the Inverter’s internal frequency continues to be calculated as usual. Therefore, if the external base block is cleared when the frequency is not zero, the frequency calculated at that point will be output. Because of this, if the baseblock is cleared during deceleration while the motor is free running, a large discrepancy between the motor speed at that moment and the Inverter output frequency may result in a main circuit overvoltage (OV) or overcurrent (OC).

■ **Speed Search (Set Value: 14, 15)**

- The speed search function is provided for smooth restarting without stopping a free running motor. Use it when switching the motor from a commercial power supply operation to Inverter operation, when starting with the Inverter a motor turned by external force, and so on.
- The speed search function searches for the present motor speed, from high frequency to low. When the motor's rotation speed is detected, it is accelerated from that frequency to the frequency reference according to the acceleration/deceleration time setting.

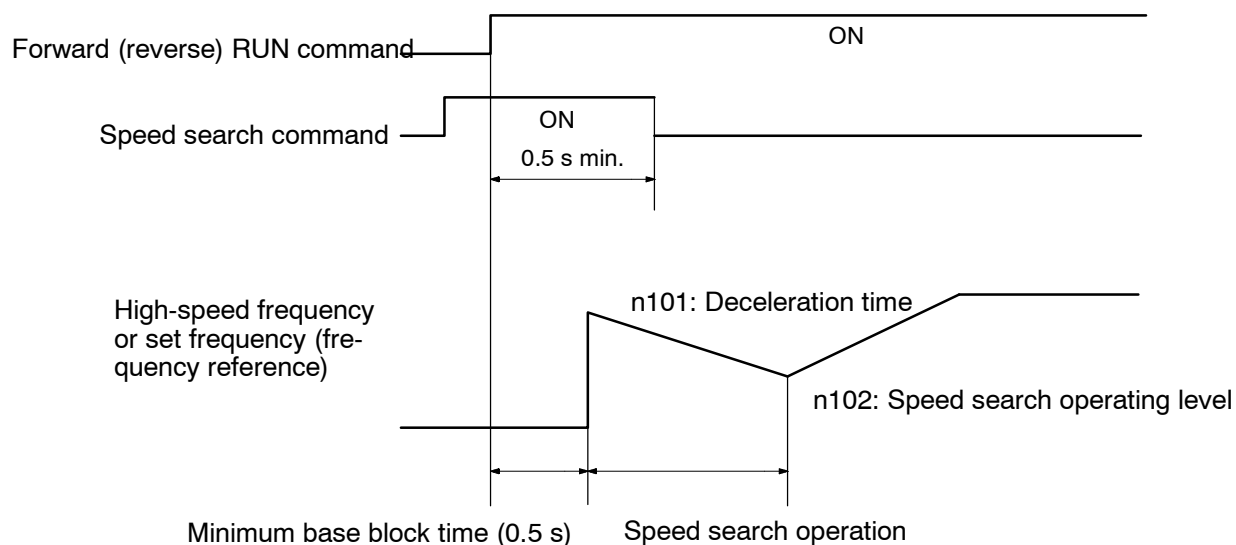

Note For 5.5- and 7.5-kW Inverters only, the speed search function can be adjusted by setting parameters n101 (speed search deceleration time) and n102 (speed search operating level). If the speed search cannot be executed properly using the default setting, lengthen the deceleration time or lower the operating level. To reduce the speed search time, check with the application while either shortening the deceleration time or raising the operating level.

n101	Speed Search Deceleration Time	Register	0165 Hex	Changes during operation	No
Setting range	0.0 to 10.0	Unit of setting	0.1 s	Default setting	2.0

n102	Speed Search Operating Level	Register	0166 Hex	Changes during operation	No
Setting range	0 to 200	Unit of setting	1 %	Default setting	150

- For n101, set the origin search deceleration time to the time required to go from 100% to 0% of the maximum frequency.
- If 0 is set for the origin search deceleration time, operation will be carried out at the default setting of 2.0 seconds.
- For n102, set the operating level as a percentage, with the Inverter's rated input taken as 100%. If the Inverter's output current drops below the level of the Inverter's output current, the speed search will be completed and acceleration will be resumed.

5-10-2 Multi-function digital Output

The 3G3MV incorporates three multi-function digital output terminals: one multi-function contact output (MA-MC) and two multi-function photocoupler outputs (P1 and P2).

Output from these terminals has a variety of functions according to the application.

■ Selecting the Multi-function digital Output (n050 through n056)

n057	Multi-function digital Output 1 (MA/MB and MC)	Register	0139 Hex	Changes during operation	No
Setting range	1 to 7, 10 to 21 (see note)	Unit of setting	1	Default setting	0
n058	Multi-function digital Output 2 (P1 and PC)	Register	013A Hex	Changes during operation	No
Setting range	1 to 7, 10 to 21 (see note)	Unit of setting	1	Default setting	1
n059	Multi-function digital Output 3 (P2 and PC)	Register	013B Hex	Changes during operation	No
Setting range	1 to 7, 10 to 21 (see note)	Unit of setting	1	Default setting	2

Note Set values 20 and 21 are available for 5.5- and 7.5-kW Inverters only.

Set Values

Value	Function	Description
0	Fault output	ON: Fault output (with protective function working)
1	Operation in progress	ON: Operation in progress (with RUN command input or inverter output)
2	Frequency detection	ON: Frequency detection (with frequency reference coinciding with output frequency)

Value	Function	Description
3	Zero speed	ON: Idling (at less than min. output frequency)
4	Frequency detection 1	ON: Output frequency \square frequency detection level (n095)
5	Frequency detection 2	ON: Output frequency \square frequency detection level (n095)
6	Overtorque being monitored (NO-contact output)	Output if any of the following parameter conditions is satisfied. <ul style="list-style-type: none"> • Overtorque detection function selection 1 (n096) • Overtorque detection function selection 2 (n097)
7	Overtorque being monitored (NC-contact output)	<ul style="list-style-type: none"> • Overtorque detection level (n098) • Overtorque detection time (n099) <p>Note NO contact: ON with overtorque being detected; NC contact: OFF with overtorque being detected</p>
8	Undertorque detection (NO)	Closed if undertorque is detected
9	Undertorque detection (NC)	Open if undertorque is detected
10	Alarm output	ON: Alarm being detected (Nonfatal error being detected)
11	Base block in progress	ON: Base block in progress (in operation with power output turned OFF)
12	RUN mode	ON: Local mode (with the Digital Operator)
13	Inverter ready	ON: Inverter ready to operate (with no fault detected)
14	Fault retry	ON: Fault retry (Inverter resetting with fault retry (n082) not set to 0)
15	UV in progress	ON: Undervoltage being monitored (main circuit undervoltage UV1 detected)
16	Rotating in reverse direction	ON: Rotating in reverse direction
17	Speed search in progress	ON: Speed search in progress
18	Communications output	ON: Communications output (turns ON/OFF according to 0009 Hex set from communications. Communications setting = ON)
19	PID feedback loss	ON: PID feedback being lost (set detection method in n136, n137, n138)
20	Frequency reference is missing	Closed if frequency reference is missing.
21	Inverter overheating pre-alarm OH3	Closed if inverter overheating pre-alarm is input. Digital operator display is "OH3" (blinking)

Note 1. Use “during RUN” (set value: 1) or “zero speed” (set value: 3) for the timing for stopping the motor using a brake. To specify a precise stop timing, set “frequency detection 1” (set value: 4) or “frequency detection 2” (set value: 5), and set the frequency detection level (n095).

Note 2. Set values 20 (frequency reference loss) and 21 (Inverter overheating warning oH3) are available for 5.5- and 7.5-kW Inverters only.

5-11 Multi-function Analog Output and Pulse Monitor Output

The 3G3MV Inverter incorporates a multi-function analog output terminal (AM-AC). A parameter setting makes it possible to output pulse monitor signals from these terminals. Make the necessary settings in these terminals according to the application.

5-11-1 Setting the Multi-function Analog Output (n065 through n067)

- By setting n065 for multi-function analog output type selection to 0 for analog voltage output, analog monitoring is possible through the multi-function analog output terminal.
- A monitoring item is set in n066 (multi-function analog output selection). Six items including the output frequency and current are available.
- Set the analog output characteristics in n067 (multi-function analog output gain).

n065	Multi-function Analog Output Type Selection	Register	0141 Hex	Changes during operation	No
Setting range	0, 1	Unit of setting	1	Default setting	0

Set Values

Value	Description
0	Analog voltage output (with monitoring item set in n066)
1	Pulse train output (according to output frequency set in n150)

n066	Multi-function Analog Output	Register	0142 Hex	Changes during operation	No
Setting range	0 to 5	Unit of setting	1	Default setting	0

Set Values

Value	Description
0	Output frequency (Reference: 10-V output at max. frequency)
1	Output current (Reference: 10-V output at rated inverter output current)
2	Main circuit DC voltage (Reference: 10-V output at 400 VDC for 200-V models and 800 VDC for 400-V models)
3	Vector operation torque monitor (Reference: 10-V output at rated motor torque)

Value	Description
4	Output power (Reference: 10-V output at power equivalent to max. applicable motor capacity and 0-V output during regenerative operation).
5	Output voltage (Reference: 10-V output at 200 VAC for 200-V models and 400 VAC for 400-V models)

Note Output power cannot be monitored in vector control mode

n067	Multi-function Analog Output Gain	Register	0143 Hex	Changes during operation	Yes
Setting range	0.00 to 2.00	Unit of setting	0.01	Default setting	1.00

Note 1. Refer to the above information on the set values in n066 and set the multiplication rate based on the reference value. For example, if 5-V output is desired at maximum output frequency (with n066 set to 0), set n067 to 0.50.

Note 2. The multi-function analog output terminals (AM and AC) have a maximum output of 10 V.

5-11-2 Setting the Pulse Monitor Output (n065 and n150)

- By setting n065 for multi-function analog output type selection to 1 for pulse train output, monitoring pulse output frequency signals is possible through the multi-function analog output terminals.
- The relationship between the output frequency and pulse train output frequency is set in n150 for multi-function analog output, pulse train frequency selection.

n065	Multi-function Analog Output Type Selection	Register	0141 Hex	Changes during operation	No
Setting range	0, 1	Unit of setting	1	Default setting	0

Set Values

Value	Description
0	Analog voltage output (with monitoring item set in n066)
1	Pulse train output (according to output frequency set in n150)

n150	Multi-function Analog Output, Pulse Train Frequency Selection	Register	0197 Hex	Changes during operation	No
Setting range	0, 1, 6, 12, 24, and 36	Unit of setting	1	Default setting	0

Set Values

Value	Description
0	1440 Hz at max. frequency (A proportional relationship is applied to frequencies less than the maximum frequency)
1	1x output frequency
6	6x output frequency
12	12x output frequency
24	24x output frequency
36	36x output frequency

Note The pulse train voltage is 10 V at high level and 0 V at low level at a duty rate of 50%.

Please also refer to page 2-16.

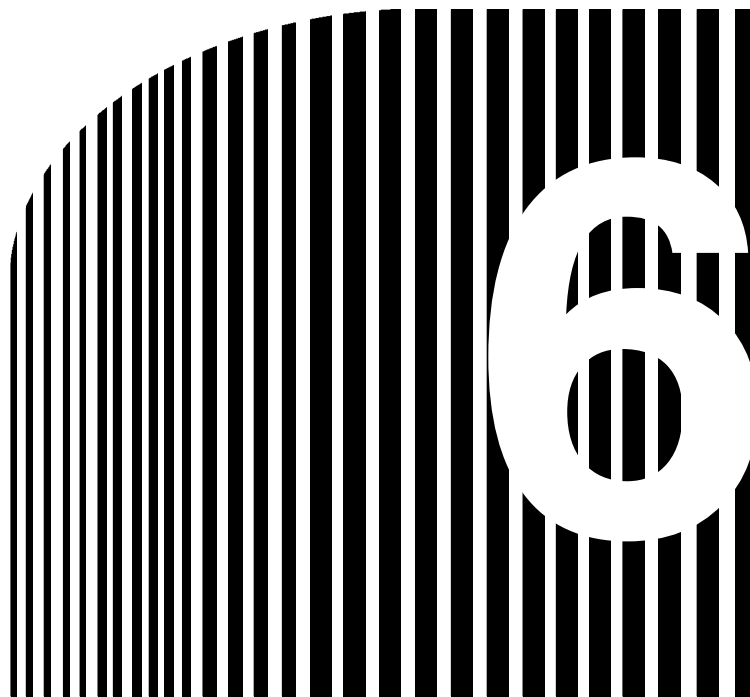

Chapter 6

• **Advanced Operation** •

- 6-1 Precise Vector Control Settings and Adjustments
- 6-2 Energy-saving Control
- 6-3 PID Control
- 6-4 Setting the Carrier Frequency
- 6-5 DC Injection Braking Function
- 6-6 Stall Prevention Function
- 6-7 Overtorque Detection Function
- 6-8 Torque Compensation Function
- 6-9 Slip Compensation Function
- 6-10 Other Functions

This chapter provides information on the use of advanced functions of the Inverter for operation.

Refer to this chapter to use the various advanced functions, such as precise vector control setting, energy-saving control, PID control, carrier frequency setting, DC injection braking, stall prevention, overtorque detection, torque compensation, and slip compensation.

6-1 Precise Vector Control Settings and Adjustments

6-1-1 Precise Vector Control Settings

- In addition to the settings described in *5-2 Operation in Vector Control*, check the motor test report and precise motor constants and make the following settings in order to make full use of the Inverter in vector control.

■ Setting the Motor Phase to neutral Resistance (n107)

- Set this parameter to 1/2 of the phase-to-phase resistance of the motor, or phase to neutral resistance at 50°C.
- Obtain from the manufacturer of each motor the test report of the motor or equivalent datasheet including precise specifications of the motor. Use the applicable formula from those listed in the following and calculate the phase to neutral resistance at 50°C from the insulation class and phase-to-phase resistance of the motor described in the test report.

Insulation class E: Phase-to-phase resistance at 75°C (Ω) \times 0.92 \times 1/2

Insulation class B: Phase-to-phase resistance at 75°C (Ω) \times 0.92 \times 1/2

Insulation class F: Phase-to-phase resistance at 115°C (Ω) \times 0.87 \times 1/2

n107	Motor Phase to neutral Resistance	Register	016B Hex	Changes during operation	No
Setting range	0.000 to 65.50 (Ω)	Unit of setting	See note 1	Default setting	See note 2

Note 1. The value will be set in 0.001- Ω increments if the resistance is less than 10 Ω and 0.01- Ω increments if the resistance is 10 Ω or over.

Note 2. The default setting for this parameter is the standard phase to neutral resistance of the maximum applicable motor.

■ Setting the Motor Leakage Inductance (n108)

- Set the motor leakage inductance in 1-mH increments.
- Motor leakage inductance is a magnetic field that is leaking externally or consumed as core loss, and is not used for torque generation.

- To insert an AC reactor for surge suppression into the output side of the Inverter, set this parameter to the motor leakage inductance added with the inductance of the AC reactor.
- The Inverter fully functions in vector control with the default setting for motor leakage inductance. Therefore, set this parameter only if the motor leakage inductance is known.

n108	Motor Leakage Inductance	Register	016C Hex	Changes during operation	No
Setting range	0.000 to 655.0 (mH)	Unit of setting	See note 1	Default setting	See note 2

Note 1. The value will be set in 0.01-mH increments if the inductance is less than 100 mH and 0.1-mH increments if the inductance is 100 mH or over.

Note 2. The default setting for this parameter is the standard leakage inductance of the maximum applicable motor.

6-1-2 Adjusting Output Torque in Vector Control

- The Inverter controls the output torque of the motor according to the required load torque in vector control. Normally, no special adjustments are required. Adjust the output torque if the maximum torque of the motor is unavailable or improvements are required in the output torque and response in a low-speed range.

■ Adjusting the Torque Compensation Limit (n109)

- Adjust the set value in n109 (torque compensation limit) if the maximum torque of the motor is insufficient or to limit the output torque to a certain degree while the motor is driven by the Inverter in vector control.
- Set the torque compensation limit in percentage based on the rated output current of the Inverter as 100%.

Compensating Torque Insufficiency

- Set n109 to a larger value if the maximum torque of the motor is insufficient.
- Set the value in 5% increments while checking the operation of the Inverter and motor.
- Check that no overload (OL1 or OL2) is detected. If an overload is detected, decrease the set values or consider the use of an Inverter model or motor with a higher capacity.

Limiting Output Torque

- Set n109 to a smaller value if the fluctuation of the output torque is large and heavy shock is imposed on the load, or excessive output torque is not required.
- Set the value according to the condition of the load.

n109	Torque Compensation Limit	Register	016D Hex	Changes during operation	No
Setting range	0 to 250 (%)	Unit of setting	1%	Default setting	150

Note 1. The Inverter in torque compensation control limits the torque at a current 1.5 times larger than the set value.

Note 2. This parameter is enabled only when the Inverter is in vector control.

■ Adjusting the Torque and Response through the V/f Pattern (n011 through n017)

- The Inverter in vector control uses the V/f pattern as the reference value of the output voltage. Therefore, by adjusting the V/f pattern the output torque and response are adjusted.
- If the application requires high torque, adjust the V/f pattern so that the output voltage at the required frequency will be high. Furthermore, energy-saving effects can be expected by decreasing the output voltage values in the frequency ranges where high torque is not required.

n011	Maximum Frequency (FMAX)	Register	010B Hex	Changes during operation	No
Setting range	50.0 to 400.0 (Hz)	Unit of setting	0.1 Hz	Default setting	60.0

n012	Maximum Voltage (VMAX)	Register	010C Hex	Changes during operation	No
Setting range	0.1 to 255.0 (0.1 to 510.0) (V)	Unit of setting	0.1 V	Default setting	200.0 (400.0)

n013	Maximum Voltage Frequency (FA)	Register	010D Hex	Changes during operation	No
Setting range	0.2 to 400.0 (Hz)	Unit of setting	0.1 Hz	Default setting	60.0

n014	Middle Output Frequency (FB)	Register	010E Hex	Changes during operation	No
Setting range	0.1 to 399.9 (Hz)	Unit of setting	0.1 Hz	Default setting	1.5

n015	Middle Output Frequency Voltage (VC)	Register	010F Hex	Changes during operation	No
Setting range	0.1 to 255.0 (0.1 to 510.0) (V)	Unit of setting	0.1 V	Default setting	11.0 (22.0)

n016	Minimum Output Frequency (FMIN)	Register	0110 Hex	Changes during operation	No
Setting range	0.1 to 10.0 (Hz)	Unit of setting	0.1 Hz	Default setting	1.5

n017	Minimum Output Voltage (VMIN)	Register	0111 Hex	Changes during operation	No
Setting range	0.1 to 50.0 (0.1 to 100.0) (V)	Unit of setting	0.1 V	Default setting	4.3 (8.6)

Note Figures in brackets are for 400-V Inverter models.

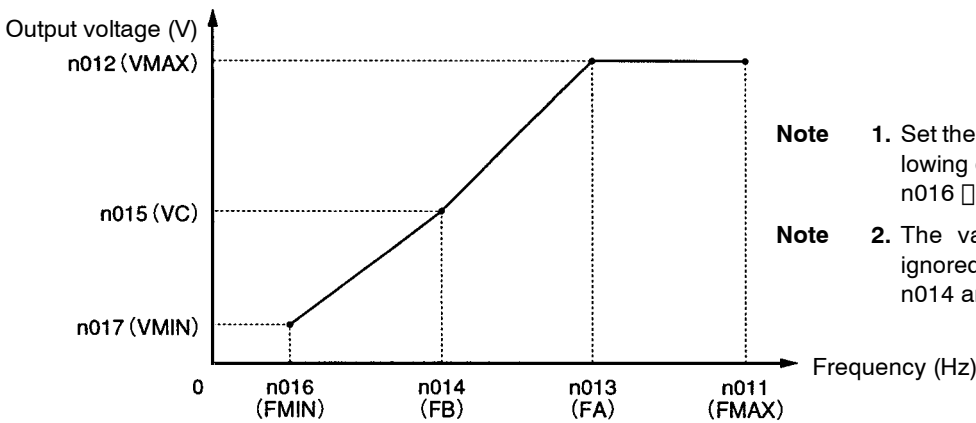

- The vertical-axis load or the load with high viscous friction may require high torque at low speed. If the torque is insufficient at low speed, increase the voltage in the low-speed range by 1 V, provided that no overload (OL1 or OL2) is detected. If an overload is detected, decrease the set values or consider the use of an Inverter model or motor with a higher capacity.
- The required torque of fan or pump control increases in proportion to the square of the speed. By setting a quadratic V/f pattern to increase the voltage in the low-speed range, the power consumption of the system will increase.

6-2 Energy-saving Control

The energy-saving control function automatically saves unnecessary power that is uselessly consumed while the load is light.

The Inverter in energy-saving control estimates the capacity of the load from the motor current and controls the output voltage of the Inverter when the load is light so that only the power required is provided to the motor.

Energy saving control is suitable for loads with little fluctuation. It is not suitable for control where responses of less than 50ms are required.

The longer the operation time of the Inverter in energy-saving control of a light load is, the more energy is saved. If the load exceeds 70% of the rated motor torque, only some energy may be saved.

This control is available to general-purpose Inverters and Inverter-dedicated motors but not applicable to special motors such as spindle motors or underwater motors.

Energy-saving control is possible in V/f control mode only and does not operate in vector control mode.

The following description provides details of the operation and adjustment of the Inverter in energy-saving control.

6-2-1 Energy-saving Control Operation

- The Inverter operates in energy-saving control as described below.

Acceleration

The Inverter accelerates normally and is not in energy-saving control.

Constant Speed

1. When the Inverter reaches the reference frequency, the Inverter operates in energy-saving control.
2. An ideal output voltage is calculated from the internal status of the Inverter and energy-saving control coefficient K2 in n140.
3. The Inverter changes the output voltage to the calculated voltage.
4. The Inverter goes into probe operation to find the point where output power is at the minimum.

Probe operation: A control method to find the point where the power is at the minimum while changing the voltage according to the probe operation control voltage step set in n145 and n146.

Deceleration

The Inverter decelerates normally and is not in energy-saving control.

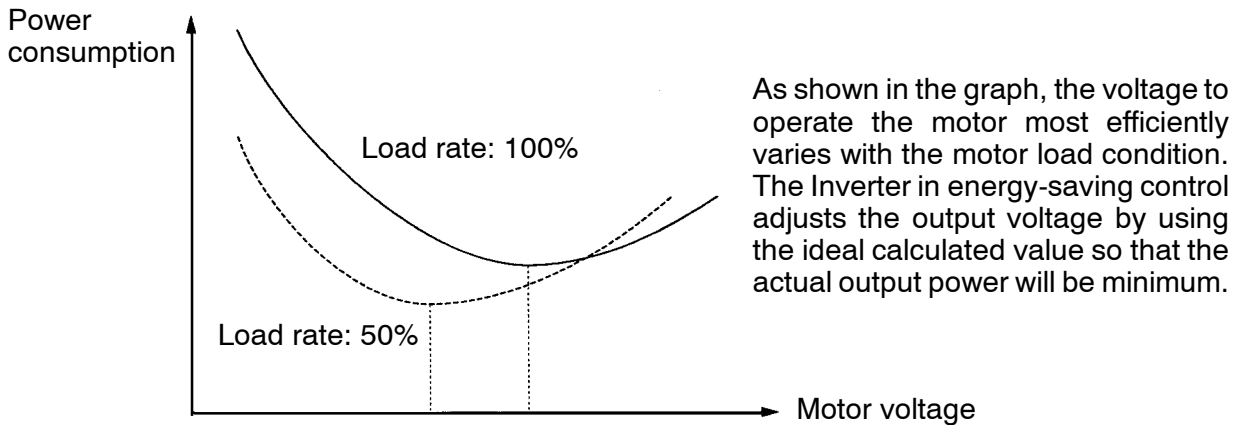

6-2-2 Performing Energy-saving Settings

n139	Energy-saving Control Selection	Register	018B Hex	Changes during operation	No
Setting range	0, 1	Unit of setting	1	Default setting	0

Set Values

Value	Description
0	Energy-saving control disabled
1	Energy-saving control enabled

Note 1. Set n139 to 1 to enable energy-saving control.

Note 2. Energy-saving control is enabled within a frequency range from 15 to 120 Hz and disabled if the frequency exceeds 120 Hz.

n158	Motor Code	Register	019E Hex	Changes during operation	No
Setting range	0 to 70	Unit of setting	1	Default setting	See note

Note The default setting varies with the capacity of the Inverter model.

Set Values

- The motor code is used for automatically setting the energy-saving constant in n140.
- By setting the motor code, the value in n140 (energy-saving control coefficient K2) will change automatically. To adjust energy-saving control coefficient K2, set the motor code in advance.

- Select the motor code from the following table based on the power supply voltage of the Inverter and the capacity of the motor.

Motor code	Power supply voltage	Motor capacity	Energy-saving control coefficient K2 (n140)
0	200 VAC	0.1 kW	481.7
1		0.2 kW	356.9
2		0.4 kW	288.2
3		0.75 kW	223.7
4		1.5 kW	169.4
5		2.2 kW	156.8
6		3.0 kW	156.8
8		4.0 kW	122.9
9		5.5 kW	94.8
10		7.5 kW	72.7
21		400 VAC	0.2 kW
22	0.4 kW		576.4
23	0.75 kW		447.4
24	1.5 kW		338.8
25	2.2 kW		313.6
26	3.0 kW		245.8
28	4.0 kW		245.8
29	5.5 kW		189.5
30	7.5 kW		145.4

n140	Energy-saving Control Coefficient K2	Register	018C Hex	Changes during operation	No
Setting range	0.0 to 6,550	Unit of setting	0.1	Default setting	See note 1

Note 1. The default setting varies with the capacity of the Inverter model.

Note 2. The constant automatically changes according to the motor code in n158. For the fine-tuning of this parameter, set the motor code in advance.

Set Values

- When the output frequency is constant for a certain period while the Inverter is in effective energy-saving control, the Inverter is set to the primary level of energy-saving control by this parameter.
- Motor constants vary with the motor manufacturer. Therefore, the fine-tuning of the parameter is required to find the ideal value. Fine-tune the parameter while the Inverter is operating at constant frequency so that the output power will be minimum.

n143	Power Averaging Time	Register	018F Hex	Changes during operation	No
Setting range	1 to 200	Unit of setting	1 (24 ms)	Default setting	1

Set Values

- Set n143 to the time required to calculate the average of power used in energy-saving control.

$$\text{Power averaging time (ms)} = \text{Set value in n143} \times 24 \text{ (ms)}$$

- Normally, the default setting does not need to be changed.
- The Inverter averages the power for the set time for energy-saving control.
- The value set in n143 is used for probe operation. The Inverter in probe operation changes the voltage at intervals set in this parameter.
- Increase the set value if the power fluctuates frequently and the Inverter cannot perform stable energy control.

n141	Energy-saving Voltage Lower Limit at 60-Hz Output	Register	018D Hex	Changes during operation	No
Setting range	0 to 120 (%)	Unit of setting	1%	Default setting	50

n142	Energy-saving Voltage Upper Limit at 6-Hz Output	Register	018E Hex	Changes during operation	No
Setting range	0 to 25 (%)	Unit of setting	1%	Default setting	12

Set Values

- When the output frequency is constant for a certain period while the Inverter is in effective energy-saving control, the Inverter is set to the primary level of energy-saving control by n140. Parameter n141 and parameter n142 prevent the output voltage of the Inverter from dropping excessively so that the motor will not stall or stop at that time.
- Set the lower limit of output voltage in percentage at each frequency based on the rated motor voltage as 100%.

- Normally, the default settings do not need to be changed. If the motor stalls or stops because the internal constants of the motor are special, increase the set values by approximately 5% to 10%.

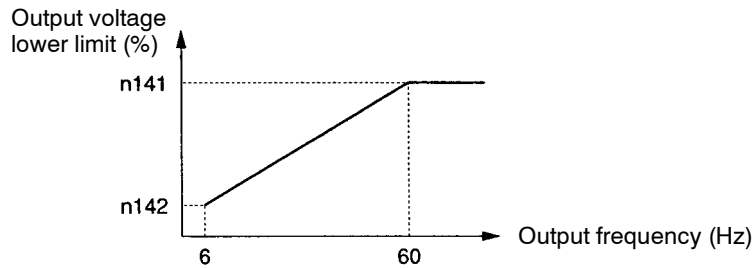

n159	Energy-saving Voltage Upper Limit at 60-Hz Output	Register	019F Hex	Changes during operation	No
Setting range	0 to 120 (%)	Unit of setting	1%	Default setting	120

n160	Energy-saving Lower Limit Voltage at 6-Hz Output	Register	01A0 Hex	Changes during operation	No
Setting range	0 to 25 (%)	Unit of setting	1%	Default setting	16

Set Values

- These parameters prevent the motor from over excitation due to voltage changes during energy-saving control.
- Set the upper limit of output voltage in percentage at each frequency based on the rated motor voltage as 100%.
- Normally, the default settings do not need to be changed.

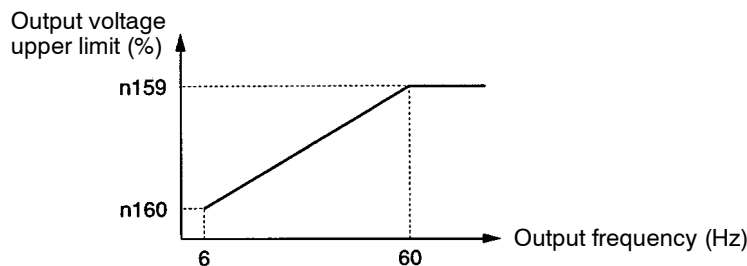

n144	Probe Operation Voltage Limit	Register	0190 Hex	Changes during operation	No
Setting range	0 to 100 (%)	Unit of setting	1%	Default setting	0

Set Values

- When the output frequency is constant for a certain period while the Inverter is in effective energy-saving control, the Inverter will be set to the primary level of energy-saving control by n140 (energy-saving constant K2). Then the Inverter will be set to the secondary level (i.e., probe operation) for more efficient, energy-saving control. Set the control voltage range of the Inverter in probe operation in parameter n144.
- Set the upper limit of probe operation voltage in percentage based on the rated motor voltage as 100%. Normally set the value to approximately 10%.
- No probe operation will be available if the value is set to 0.

n145	Probe Operation Control Voltage Step at 100%	Register	0191 Hex	Changes during operation	No
Setting range	0.1 to 10.0 (%)	Unit of setting	0.1%	Default setting	0.5
n146	Probe Operation Control Voltage Step at 5%	Register	0192 Hex	Changes during operation	No
Setting range	0.1 to 10.0 (%)	Unit of setting	0.1%	Default setting	0.2

Set Values

- Set the range of probe operation voltage in percentage based on the rated motor voltage as 100%.
- Normally, the default setting does not need to be changed.
- If the fluctuation of speed in probe operation is large, decrease the set value. If the response of the Inverter in probe operation is slow, increase the set value.

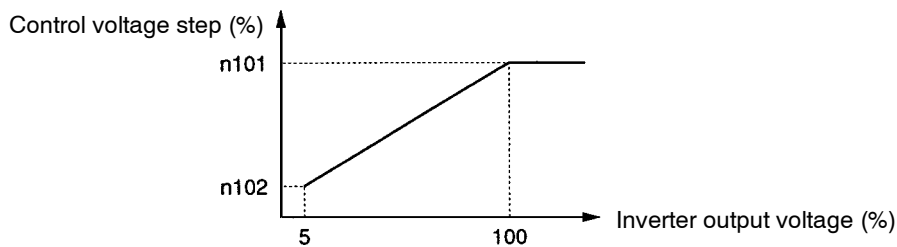

n161	Power Detection Width for Probe Operation Switching	Register	01A1 Hex	Changes during operation	No
Setting range	0 to 100 (%)	Unit of setting	1%	Default setting	10

Set Values

- Set this parameter to the detection width of power that sets the Inverter to probe operation. When the fluctuation of power is within the detection width, the Inverter will be in probe operation.

- Set the width in percentage based on the power to be detected as 100%.
- Normally, the default setting does not need to be changed.
- The Inverter will operate with a power detection width of 10% if the value is set to 0.

n162	Power Detection Filter Constant	Register	01A2 Hex	Changes during operation	No
Setting range	0 to 255	Unit of setting	1 (4 ms)	Default setting	5

Set Values

- Set this parameter to the filter time constant of the power detection block of the Inverter operating in probe operation.
Filter time constant (ms) = Set value in n162 x 4 (ms)
- Normally, the default setting does not need to be changed.
- The Inverter will operate with a time constant of 20 ms if the value is set to 0.

6-3 PID Control

Detected values of the Inverter in proportional, integral, and derivative (PID) control are fed back so that the values will coincide with preset target values.

Proportional control, integral control, and derivative control in combination are available to machinery systems involving redundancy time in control operation. The PID control function of the 3G3MV Inverter is not suitable to the control of systems that require a response of 50 ms or quicker, however.

The following description provides the applications and operation of PID control together with required parameter settings and adjustments.

6-3-1 PID Control Applications

- The following table provides application examples of the Inverter in PID control.

Application	Control	Sensor used (example)
Speed control	The speed data of the machinery system is fed back so that the operating speed of the machinery system will coincide with the target value. The speed data of another machinery system is input as a target value and the actual operating speed of the machinery is fed back for synchronous control.	Tacho generator
Pressure control	Data on pressure is fed back for constant pressure control.	Pressure sensor
Flow rate control	Data on the flow rate of liquid is fed back for precise flow control.	Flow sensor
Temperature control	Data on temperature is fed back for temperature control using fan operation.	Thermocouple Thermistor

6-3-2 PID Control Operation

- To simply explain the operation of proportional control, integral control, and derivative control, the following graph is used to show that the output frequency changes while the deviation (i.e., the difference between the target value and feedback value) is constant.

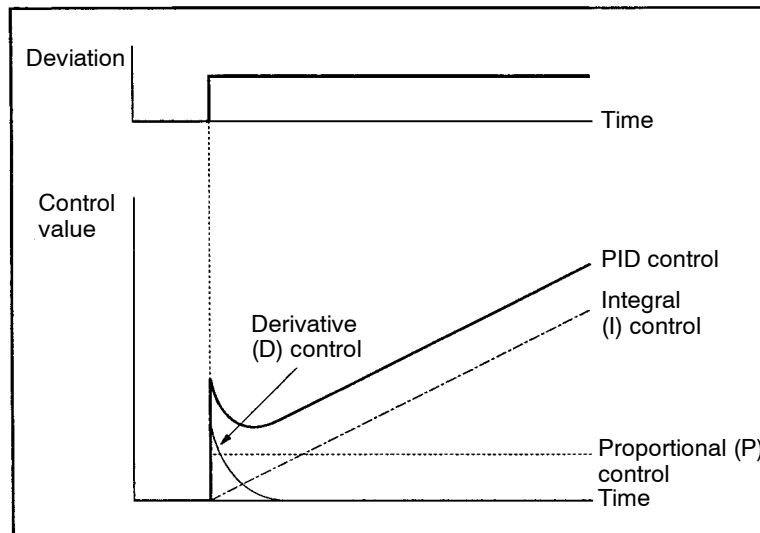

- **Proportional (P) Control:** The output is in proportion to the deviation. The deviation cannot be set to 0 with proportional control only.
- **Integral (I) Control:** The output is the integral value of the deviation. This control method makes the feedback value coincide with the target value effectively but cannot catch up with a rapid change in deviation.
- **Derivative (D) Control:** The output is the derivative value of the deviation. This control method quickly responds to a rapid change in deviation.
- **PID Control:** By combining the merits of the above control functions, ideal control is possible.

6-3-3 Types of PID Control

- Two types of PID control are available to the 3G3MV Inverter. Normally, feedback-value integral PID control is used.

• **Feedback-value Integral PID Control**

In this control, the feedback integral value is used. The Inverter normally uses this control method. The response will be comparatively slow if the target value changes because the feedback integral value is used. The stable control of the target is, however, possible.

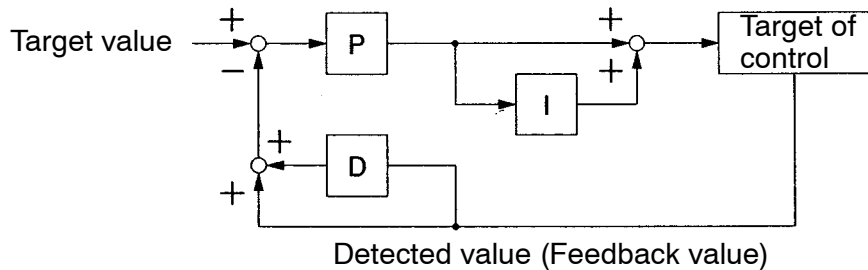

• **Basic PID Control**

This is the basic control method. The response will be quick if the target value changes because the deviation integral value is used. If the target value changes rapidly, however, the control value of the derivative control block will be large. As a result, overshooting or undershooting may result.

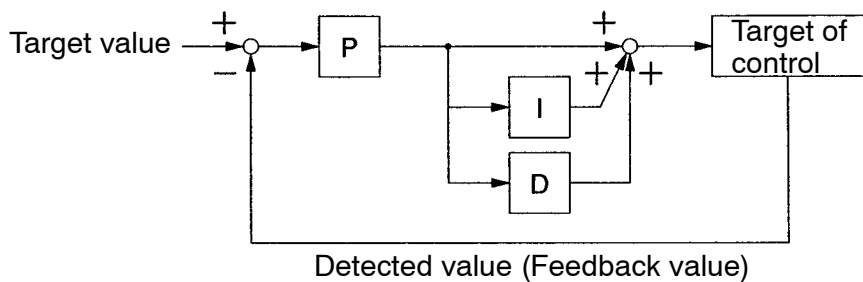

- Furthermore, 3G3MV Inverter can add the frequency reference to the operation result of the PID control block.

If the target of control is motor speed, by adding the frequency reference, motor speed control with high-speed response will be possible.

Do not add the frequency reference if the target of control is temperature or pressure.

6-3-4 Block Diagram of PID Control

• The following diagram shows the PID control block of the 3G3MV Inverter.

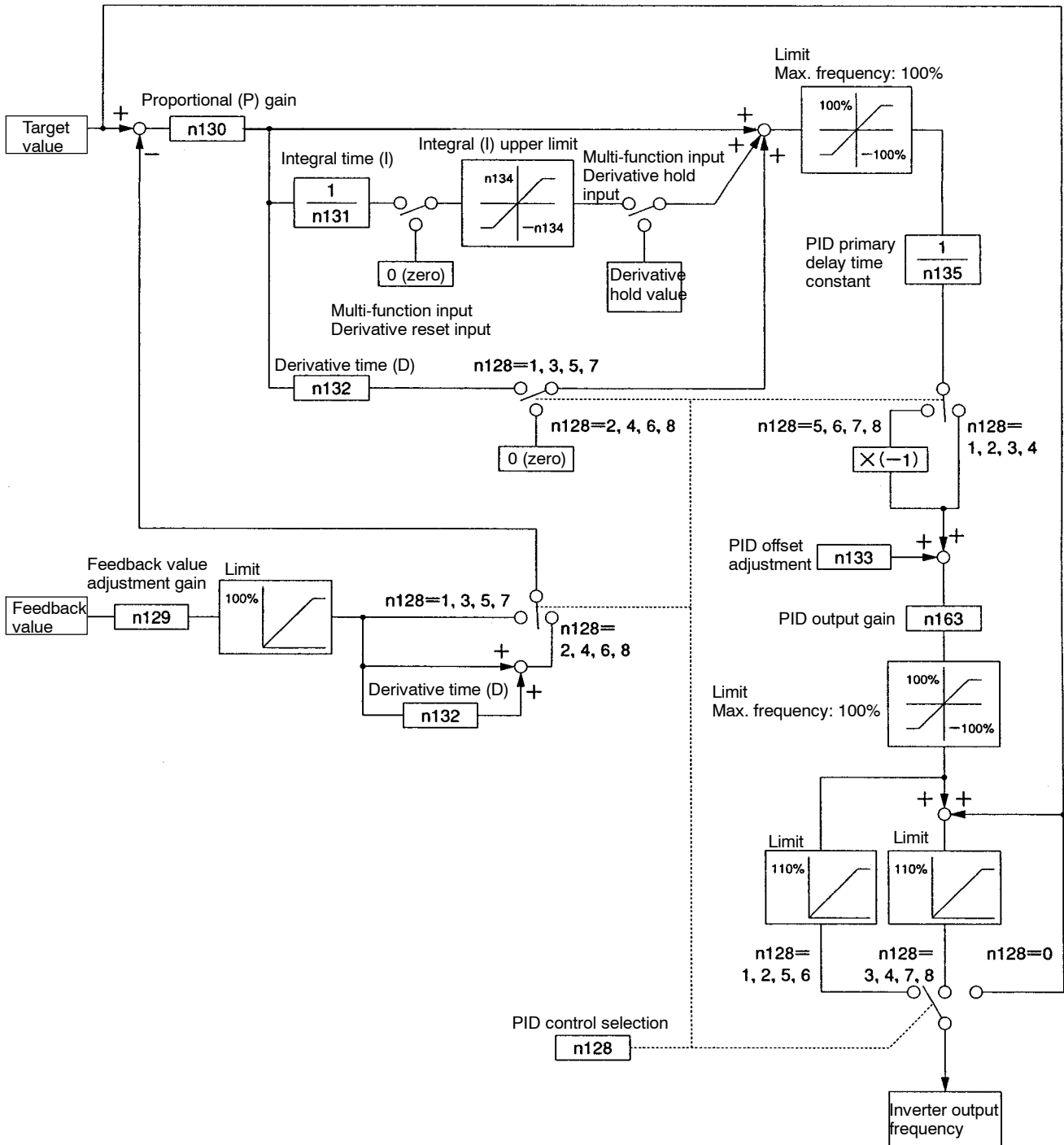

6-3-5 Input Selection of PID Control Target Value and Detection Value

- The target value and detected value (feedback value) of PID control are set according to n004 for frequency reference selection, n008 for local mode frequency reference selection, and n164 PID feedback input block selection as shown in the following diagram.

Make sure that the target value input and feedback value input do not overlap with each other. Setting details are provided from the next page onward.

Input Selection of PID Control Target Value

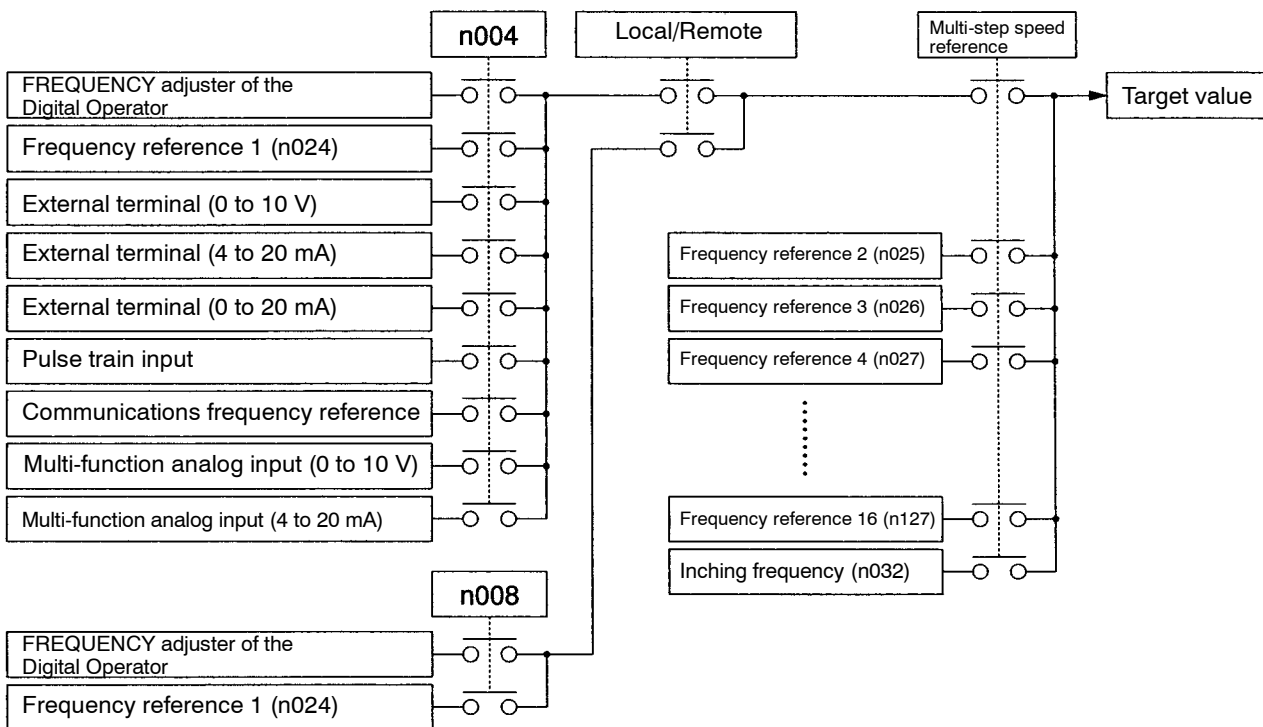

Input Selection of PID Control Detection Value

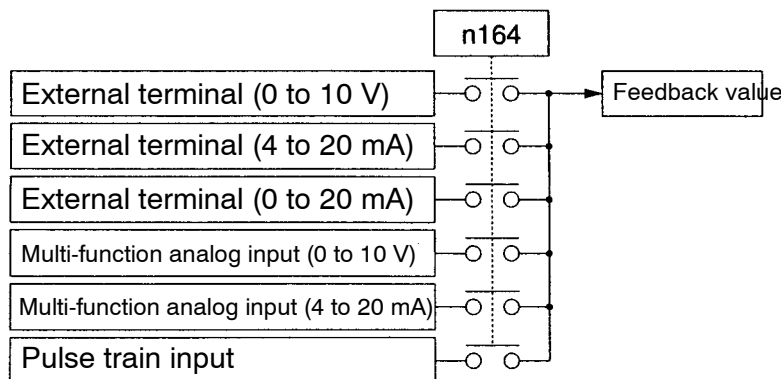

6-3-6 PID Control Settings

n128	PID Control Selection	Register	0180 Hex	Changes during operation	No
Setting range	0 to 8	Unit of setting	1	Default setting	0

Set Values

Value	Description			
	PID control	Derivative control method	Addition of frequency reference	Positive or negative characteristics
0	Disabled	---	---	---
1	Enabled	Deviation integrated	No	Positive
2	Enabled	Feedback value integrated	No	Positive
3	Enabled	Deviation integrated	Yes	Positive
4	Enabled	Feedback value integrated	Yes	Positive
5	Enabled	Deviation integrated	No	Negative
6	Enabled	Feedback value integrated	No	Negative
7	Enabled	Deviation integrated	Yes	Negative
8	Enabled	Feedback value integrated	Yes	Negative

Note 1. Normally select feedback-value integral PID control as the derivative control method.

Note 2. Add the frequency reference if the target of control is motor speed and do not add the frequency reference if the target of control is temperature or pressure.

Note 3. Set positive or negative characteristics according to the characteristics of the detector. If the feedback value is decreased with the output frequency increased, set negative characteristics.

n129	Feedback Value Adjustment Gain	Register	0181 Hex	Changes during operation	Yes
Setting range	0.00 to 10.00	Unit of setting	0.01	Default setting	1.00

Set Values

- Set the multiplication rate of the feedback value.

- This parameter adjusts the feedback value so that the input level of the input device, such as a sensor, will coincide with the input level of the target value.

For example, if the target value of 1,000 rpm is input as 10 V and the Feedback Value Adjustment Gain should be set to 2.

n130	Proportional (P) Gain	Register	0182 Hex	Changes during operation	Yes
Setting range	0.0 to 25.0	Unit of setting	0.1	Default setting	1.0

n131	Integral (I) Time	Register	0182 Hex	Changes during operation	Yes
Setting range	0.0 to 360.0 (s)	Unit of setting	0.1 s	Default setting	1.0

n132	Derivative (D) Time	Register	0182 Hex	Changes during operation	Yes
Setting range	0.0 to 2.50 (s)	Unit of setting	0.01 s	Default setting	0.00

Set Values

- While the mechanical load is in actual operation, adjust the values so that the best response will be returned from the load. Refer to *6-3-7 PID Adjustments*.
- If n130 (proportional gain) is set to 0.0, PID control will be disabled. Not only proportional control but also all PID control will be disabled.
- If n131 (integral time) is set to 0.0, integral control will be disabled.
- If n132 (derivative time) is set to 0.0, derivative control will be disabled.

n133	PID Offset Adjustment	Register	0185 Hex	Changes during operation	Yes
Setting range	-100 to 100 (%)	Unit of setting	1%	Default setting	0

Set Values

- This parameter is for the offset adjustment of all PID control.
- Adjust the parameter so that the output frequency of the Inverter will be 0 when the target value and feedback value are both set to 0.

n134	Integral (I) Upper Limit	Register	0186 Hex	Changes during operation	Yes
Setting range	0 to 100 (%)	Unit of setting	1%	Default setting	100

Set Values

- Set this parameter to the upper limit of integral control output.

- Set the value in percentage based on the maximum frequency as 100%.
- The integral upper limit is set so that the output frequency will not be excessively high when the deviation is large.

n135	PID Primary Delay Time	Register	0187 Hex	Changes during operation	Yes
Setting range	0.0 to 10.0 (s)	Unit of setting	0.1 s	Default setting	0.0

Set Values

- Set this parameter to the primary delay time constant for the frequency reference after PID control.
- Normally, the default setting does not need to be changed.
- If load is a mechanical one with high viscous friction or low rigidity, the load may resonate. If that happens, set a value larger than the resonant frequency of the load so that the load will not resonate, even though the response will be slower.

n136	Feedback Loss Detection Selection	Register	0188 Hex	Changes during operation	No
Setting range	0 to 2	Unit of setting	1	Default setting	0

Set Values

Value	Description
0	Feedback loss detection disabled
1	Feedback loss detection enabled (Nonfatal error: FbL warning)
2	Feedback loss detection enabled (Fatal error: FbL error)

Note 1. Set the method of detecting loss of the feedback as a detected value for PID control.

Note 2. If the detection level set in n137 or lower is detected for the set time in n138, the result will be determined as feedback loss.

n137	Feedback Loss Detection Level	Register	0189 Hex	Changes during operation	No
Setting range	0 to 100 (%)	Unit of setting	1%	Default setting	0

n138	Feedback Loss Detection Time	Register	018A Hex	Changes during operation	No
Setting range	0.0 to 25.5 (s)	Unit of setting	0.1 s	Default setting	1.0

Set Values

- These parameters are reference values for detecting loss of feedback for PID control.

- Set n137 to the feedback level in percentage based on the feedback level at maximum frequency as 100%.
- Set n138 in 0.1-s increments for the permissible continuous period of the feedback signal level that is the same as or less than the feedback level set in n137.

n163	PID Output Gain	Register	01A3 Hex	Changes during operation	No
Setting range	0.0 to 25.0	Unit of setting	0.1	Default setting	1.0

Set Values

- Set this parameter to a rate by which PID control value is multiplied for PID control.
- Normally, the default setting does not need to be changed.
- This parameter is used for the adjustment of the PID control value to be added with the frequency reference.

n164	PID Feedback Input Block Selection	Register	01A4 Hex	Changes during operation	No
Setting range	0 to 5	Unit of setting	1	Default setting	0

Set Values

Value	Description
0	Frequency reference control terminal for 0- to 10-V voltage input is enabled. (see note 1)
1	Frequency reference control terminal for 4- to 20-mA current input is enabled. (see note 2)
2	Frequency reference control terminal for 0- to 20-mA current input is enabled. (see note 2)
3	Multi-function analog voltage (0- to 10-V) input is enabled. Used only if two analog inputs are required in PID control.
4	Multi-function analog current (4- to 20-mA) input is enabled. Used only if two analog inputs are required in PID control.
5	Pulse train reference control terminal is enabled. (see note 3)

Note 1. The maximum frequency (FMAX) is reached with 10-V input.

Note 2. The maximum frequency (FMAX) is reached with 20-mA input, if the SW2 on the control PCB was changed from V (voltage) to I (current).

Note 3. Set n149 for the pulse train input scale to the pulse train frequency that is equivalent to the maximum frequency (FMAX).

Note 4. Make sure that the target value input and feedback value input do not overlap with each other.

6-3-7 PID Adjustments

■ PID Adjustments with Step Response Method

- The following describes how to adjust each parameter of PID control by monitoring the step response of the target of control.

1. Measurement of Step Response Waveform

Take the following steps to measure the step response waveform of the target of control.

- a) Connect the load in the same way as the connection of the load to the Inverter in normal operation.
- b) Set n128 to 0 so that the Inverter will not perform PID control.
- c) Minimize the acceleration time and input the step frequency reference.
- d) Measure the response waveform of the feedback.

Note Measure the response waveform so that the timing of the step input will be known.

2. Calculation of PID Parameters

- Draw a tangent line that comes into contact with the steepest inclination point of the response waveform.
- **Measurement of R**
Measure the gradient of the tangent line provided that the set point is 1.
- **Measurement of L**
Measure the required time (seconds) between the origin and the point of intersection of the tangent line and time axis.
- **Measurement of T**
Measure the required time (seconds) between the point of intersection of the tan-

gent line and time axis and the point of intersection of the tangent line and set point line.

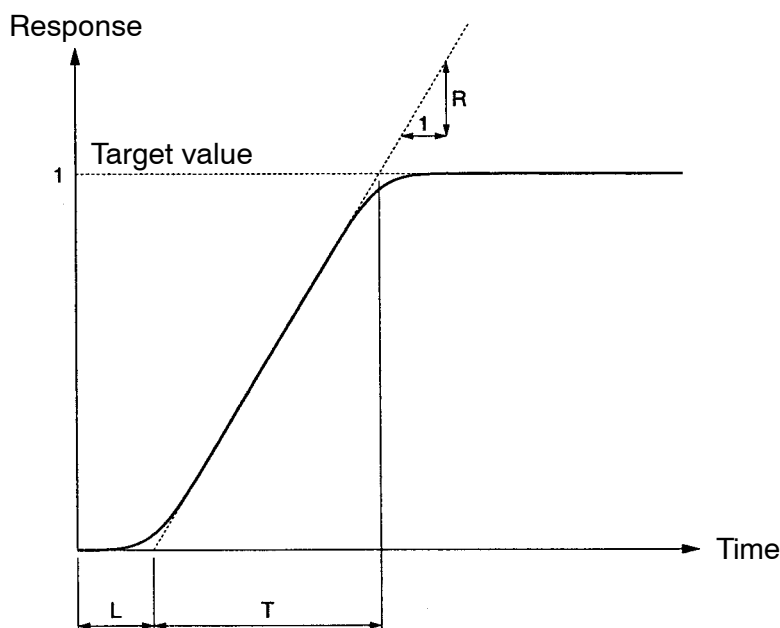

• **PID Parameter**

The following PID parameters are calculated from the R, L, and T of intersection of the tangent line and set point line as general rules.

Control	Proportional (P) gain (n130)	Integral (I) time (n131)	Derivative (D) time (n132)
P control	0.3/RL	---	---
PI control	0.35/RL	1.2T	---
PID control	0.6/RL	T	0.5L

Note 1. Obtain PID parameter values from the above method, set the PID parameters, and tune in the PID parameter values precisely.

Note 2. PID parameter values obtained from the above method may not be optimum if the friction factor of the mechanical system is large or the rigidity of the mechanical system is low.

■ **Manual PID Adjustments**

• Perform the following procedure to adjust the PID parameter values of the Inverter performing PID control by monitoring the response waveform.

1. Connect the load in the same way as the connection of the load to the Inverter in normal operation.
2. Set n128 so that the Inverter will perform PID control.
3. Increase the proportional (P) gain in n130 within a range causing no vibration.

- 4. Increase the integral (I) time in n131 within a range causing no vibration.
- 5. Increase the derivative (D) time in n132 within a range causing no vibration.

6-3-8 PID Fine Tuning

• Refer to the following to tune in PID parameters exactly.

• **Suppression of Overshooting**

Set the derivative (D) time to a smaller value and the integral (I) time to a larger value if overshooting results.

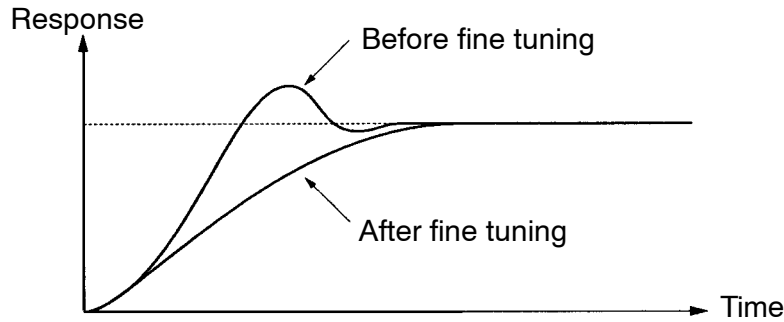

• **Prompt Stability**

Set the integral (I) time to a smaller value and the derivative (D) time to a large value for prompt stability control, even though overshooting results.

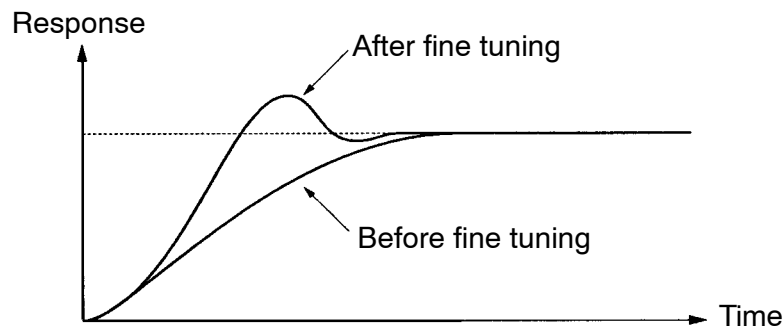

• **Suppression of Long-cycle Vibration**

Vibration with a wavelength longer than the integral (I) time results from excessive integral control. The vibration can be suppressed by setting the integral (I) time to a larger value.

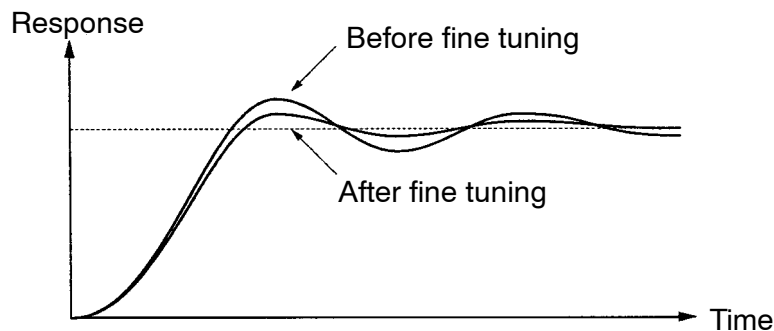

• **Suppression of Short-cycle Vibration**

Vibration with a wavelength almost as long as the differential time results from excessive derivative (D) control. The vibration can be suppressed by setting the derivative (D) time to a smaller value.

If the vibration cannot be suppressed after the differential time is set to 0.00, set the proportional gain to a smaller value or the PID primary delay time constant to a larger value.

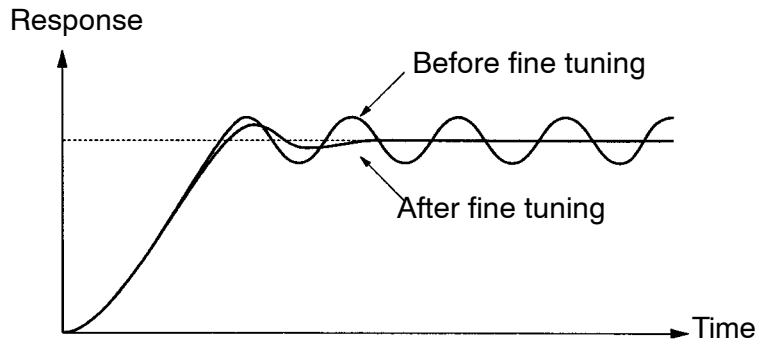

6-4 Setting the Carrier Frequency

The carrier frequency of the 3G3MV can be fixed or varied in proportion to the output frequency.

n080	Carrier Frequency Selection	Register	0150 Hex	Changes during operation	No
Setting range	1 to 4, 7 to 9	Unit of setting	1	Default setting	(see note)

Note The default setting varies with the capacity of the Inverter model.

Set Values

Value	Description
1	2.5 kHz
2	5.0 kHz
3	7.5 kHz
4	10.0 kHz
7	2.5 kHz (12×): 12 times as high as output frequency (from 1.0 to 2.5 kHz)
8	2.5 kHz (24×): 24 times as high as output frequency (from 1.0 to 2.5 kHz)
9	2.5 kHz (36×): 36 times as high as output frequency (from 1.0 to 2.5 kHz)

- The default setting does not need any changes in normal operation.
- Change the default setting in the following cases.

The wiring distance between the Inverter and motor is long:

Set the Inverter to a lower carrier frequency.

Reference carrier frequency:	Wiring distance ≤ 50 m:	10 kHz
	50 m < Wiring distance ≤ 100 m:	5 kHz
	Wiring distance > 100 m:	2.5 kHz

Note The carrier frequency changes as shown in the following graph with 7 through 9 set in n46.

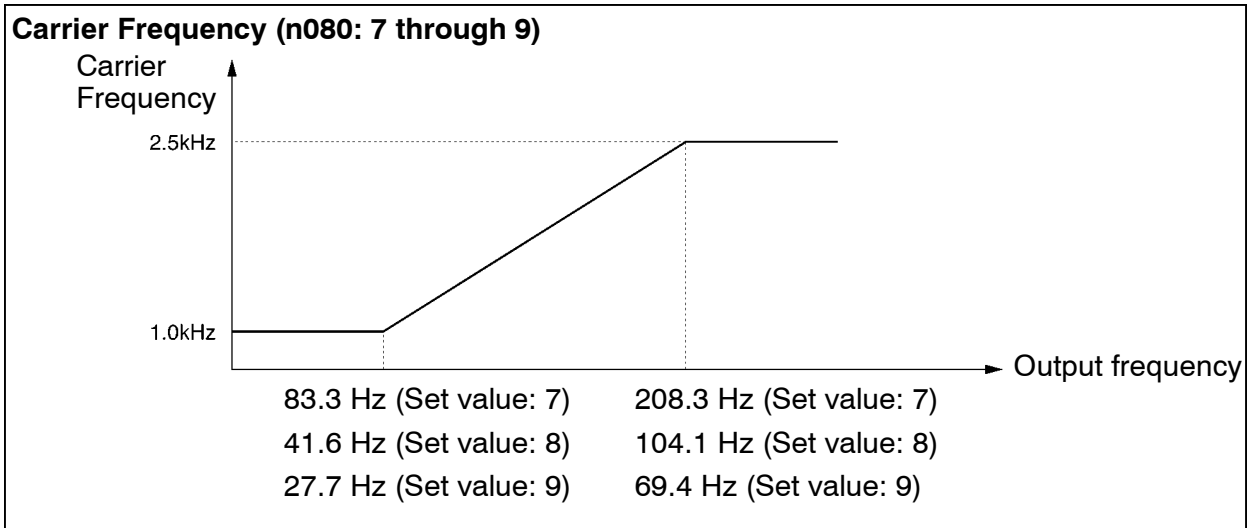

- The Inverter cannot maintain rated output current with the carrier frequency set to a value higher than the default one.

The following table shows the default settings and the reduced rated inverter output currents resulting from a higher setting for the carrier frequency for each Inverter model.

When the carrier frequency is set to a higher value than the default setting, use the Inverter at a current less than the reduced rated output current.

Voltage	Model 3G3MV-	Default setting	Rated output current (A)	Set to 3 Reduced rated output current (A)	Set to 4 Reduced rated output current (A)
3-phase 200 V	A2001	4 (10 kHz)	0.8	←	←
	A2002	4 (10 kHz)	1.6	←	←
	A2004	4 (10 kHz)	3.0	←	←
	A2007	4 (10 kHz)	5.0	←	←
	A2015	3 (7.5 kHz)	8.0	←	7.0
	A2022	3 (7.5 kHz)	11.0	←	10.0
	A2040	3 (7.5 kHz)	17.5	←	16.5
	A2055	3 (7.5 kHz)	25	←	23
	A2075	3 (7.5 kHz)	33	←	30

Voltage	Model 3G3MV-	Default setting	Rated output current (A)	Set to 3 Reduced rated output current (A)	Set to 4 Reduced rated output current (A)
Single-phase 200 V	AB001	4 (10 kHz)	0.8	←	←
	AB002	4 (10 kHz)	1.6	←	←
	AB004	4 (10 kHz)	3.0	←	←
	AB007	4 (10 kHz)	5.0	←	←
	AB015	3 (7.5 kHz)	8.0	←	7.0
	AB022	3 (7.5 kHz)	11.0	←	10.0
	AB040	3 (7.5 kHz)	17.5	←	16.5
3-phase 400 V	A4002	3 (7.5 kHz)	1.2	←	1.0
	A4004	3 (7.5 kHz)	1.8	←	1.6
	A4007	3 (7.5 kHz)	3.4	←	3.0
	A4015	3 (7.5 kHz)	4.8	←	4.0
	A4022	3 (7.5 kHz)	5.5	←	4.8
	A4030	3 (7.5 kHz)	7.2	←	6.3
	A4040	3 (7.5 kHz)	9.2	←	8.1
	A4055	3 (7.5 kHz)	14.8	←	←
	A4075	3 (7.5 kHz)	18	←	17

n175	Low Carrier Frequency at Low Speed	Register	01AF Hex	Changes during operation	No
Setting range	0, 1	Unit of setting	1	Default setting	0

Note For 5.5- and 7.5-kW Inverters, the default setting is “1” (enable).

Set Values

Value	Description
0	Low carrier frequency at low speed disabled.
1	Low carrier frequency at low speed enabled.

- Normally set n175 to 0 (except for 5.5 and 7.5kW Inverters).
- When the output frequency is 5 Hz or less and the output current rate is 110% or more, the carrier frequency will be automatically reduced to 2.5 kHz with n175 set to 1. If the load is heavy at low speed, the Inverter will withstand higher overcurrent by suppressing the heat radiation of the Inverter caused by the carrier frequency.
- This function is enabled with 2, 3, or 4 set in n080 for carrier frequency.

6-5 DC Injection Braking Function

The DC injection braking function applies DC on the induction motor for braking control.

Startup DC Injection Braking:

This braking is used for stopping and starting the motor rotating by inertia with no regenerative processing.

DC Injection Braking to Stop:

Adjust the stop DC injection braking time if the motor rotating does not decelerate to a stop in normal operation due to inertia from a heavy load. By increasing the DC injection braking time or DC injection braking current, the time required for stopping the motor is reduced.

n089	DC Injection Braking Current	Register	0159 Hex	Changes during operation	No
Setting range	0 to 100 (%)	Unit of setting	1%	Default setting	50
n090	DC Injection Braking-to-stop Time	Register	015A Hex	Changes during operation	No
Setting range	0.0 to 25.5 (s)	Unit of setting	0.1 s	Default setting	0.5
n091	Startup DC Injection Braking Time	Register	015B Hex	Changes during operation	No
Setting range	0.0 to 25.5 (s)	Unit of setting	0.1 s	Default setting	0.0

- Set the DC injection braking current as percentage based on the rated current of the Inverter as 100%.
- After the startup DC injection braking time is set, the Inverter starts up at minimum frequency on completion of the startup DC injection braking control of the Inverter.

- After the speed is reduced, the Inverter is switched to DC injection braking at minimum output frequency.

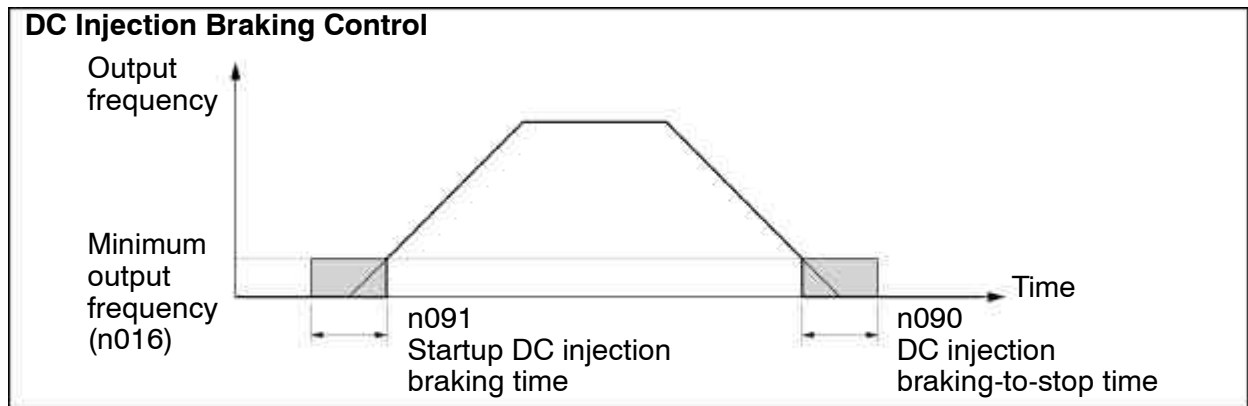

6-6 Stall Prevention Function

A stall will occur if the motor cannot keep up with the rotating magnetic field on the motor stator side when a large load is applied to the motor or a sudden acceleration/deceleration is performed.

In the 3G3MV, stall prevention functions can be set independently for accelerating, running, and decelerating conditions.

n092	Stall Prevention during Deceleration	Register	015C Hex	Changes during operation	No
Setting range	0, 1	Unit of setting	1	Default setting	0

Set Values

Value	Description
0	Stall prevention during deceleration
1	No stall prevention during deceleration

- If 1 is set, the motor will be decelerated according to the set deceleration time. If the deceleration time is too short, the main circuit may result in overvoltage.
- If 0 is set, the deceleration time will be automatically lengthened to prevent overvoltage.
- Be sure to set n092 to 1 to disable stall prevention during acceleration if the braking resistor or Braking Resistor Unit is in use. If n092 is set to 0, no deceleration time reduction will be possible because the braking resistor or Braking Resistor Unit connected is not used.

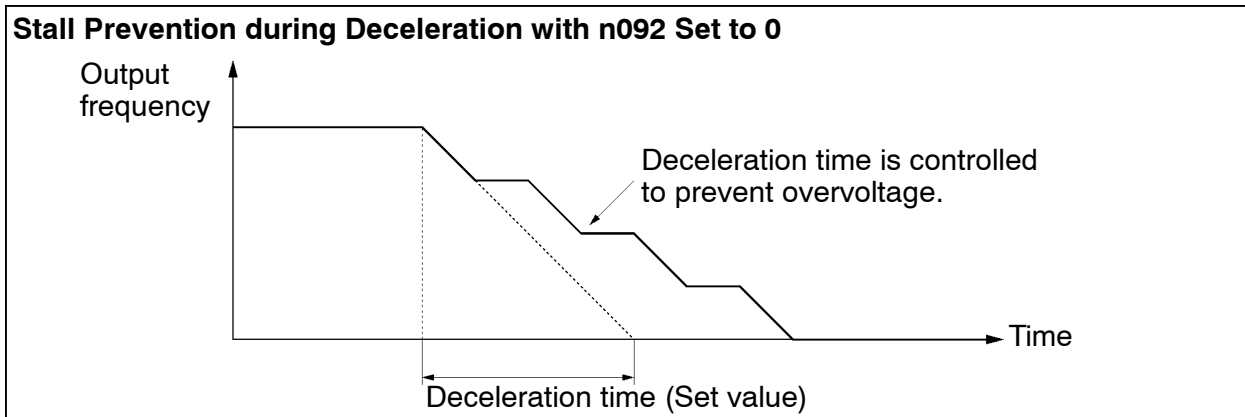

n093	Stall Prevention Level during Acceleration	Register	015D Hex	Changes during operation	No
Setting range	30 to 200 (%)	Unit of setting	1%	Set Values	170

Set Values

- This function is used to stop accelerating the load if the output current exceeds the set current value so that the Inverter will continue operating without stalling. The Inverter accelerates the load while the output current is the same as or less than the set value.
- Set the parameter as percentage based on the rated Inverter current as 100%.
- The default setting does not need any changes in normal operation.
- Decrease the set value if the capacity of the motor is smaller than that of the Inverter or the motor stalls with the default value.
The set value is normally 2 or 3 times higher than the rated current of the motor. Set this current as percentage based on the rated inverter current as 100%.

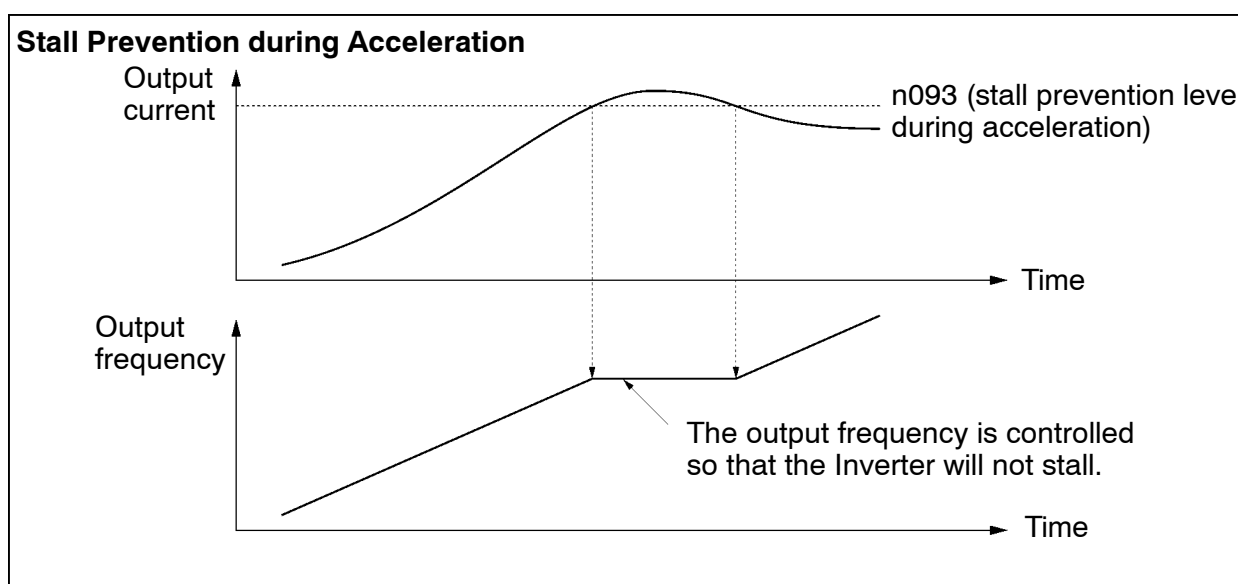

n094	Stall Prevention Level during Operation	Register	015E Hex	Changes during operation	No
Setting range	30 to 200 (%)	Unit of setting	1%	Default setting	160

Set Values

- This function will decrease the output frequency if the output current exceeds the set current value by a minimum of approximately 100 ms so that the Inverter will continue operating without stalling. The Inverter will increase the output frequency to return to the set frequency reference level when the output current is less than the set value.

- The Inverter accelerates or decelerates the output frequency according to the preset acceleration or deceleration time set in n116 (stall prevention acceleration/deceleration time setting).
- Set the parameter as percentage based on the rated Inverter current as 100%.
- The default setting does not need any changes in normal operation.
- Decrease the set value if the capacity of the motor is smaller than that of the Inverter or the motor stalls with the default value.
The set value is normally 2 or 3 times higher than the rated current of the motor. Set this current in percentage based on the rated Inverter current as 100%.

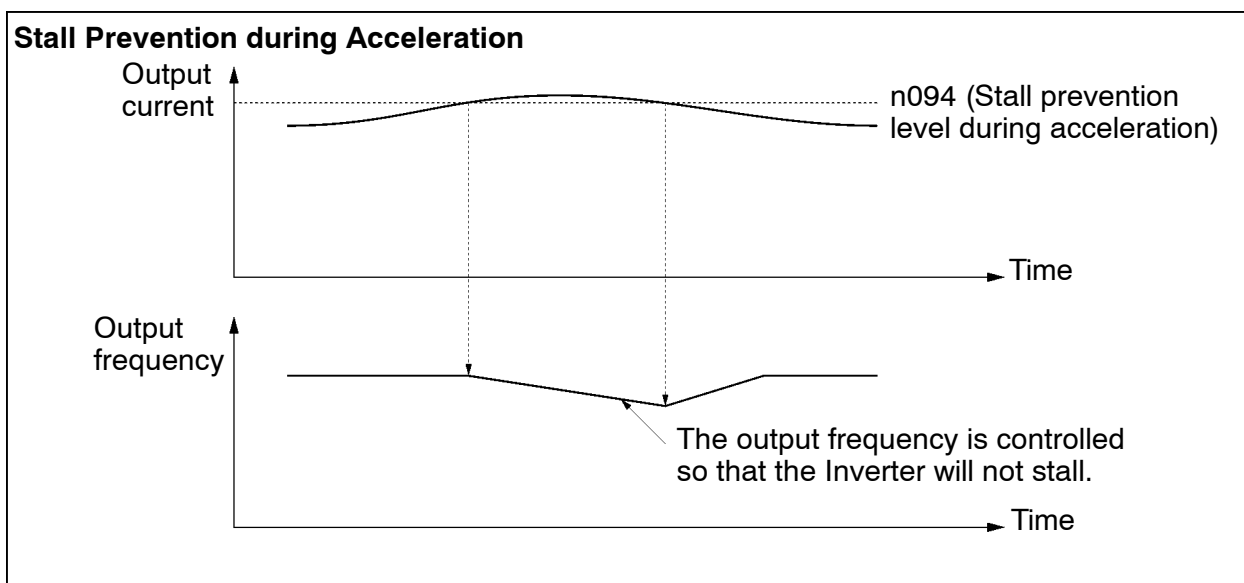

n115	Stall Prevention Level Automatic Suppression Selection	Register	0173 Hex	Changes during operation	No
Setting range	0, 1	Unit of setting	1	Set Values	0

Set Values

Value	Description
0	Disabled. The set value in n094 for stall prevention during operation is enabled in all the frequency range.
1	Enabled. The set value in n094 for stall prevention during operation is automatically decreased when the output frequency exceeds the maximum voltage frequency (n013).

- If n115 is set to 1, the stall prevention level will be suppressed as shown below. When using frequencies exceeding the maximum voltage frequency, set n 115 to 1.

Automatic Suppression of Stall Prevention Level (n115 Set to 1)

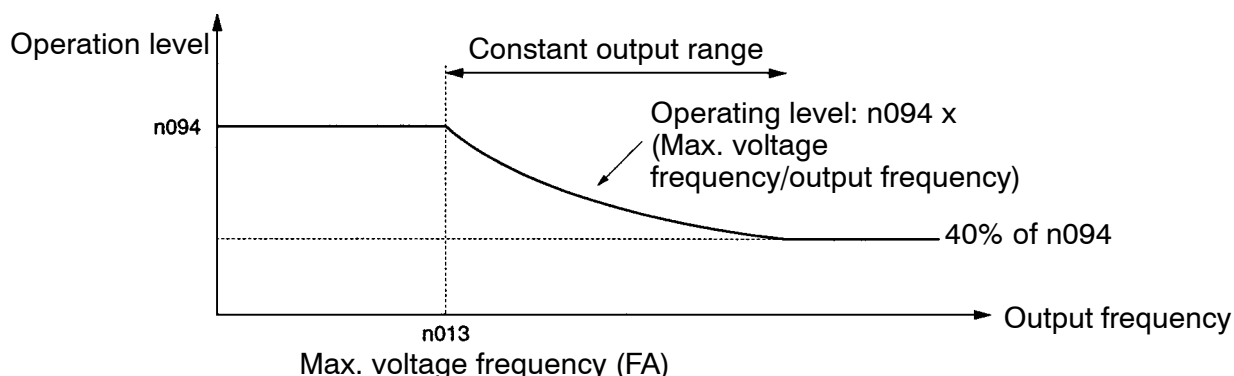

n116	Stall Prevention Acceleration/Deceleration Time Setting	Register	0174 Hex	Changes during operation	No
Setting range	0, 1	Unit of setting	1	Set Values	0

Set Values

Value	Description
0	Accelerates or decelerates at acceleration/deceleration time 1 or 2 presently selected.
1	Accelerates or decelerates at acceleration/deceleration time 2 set in n021 and n022.

- Select the acceleration/deceleration time with the stall prevention function operating function enabled.
- To accelerate or decelerate quicker or slower than normal, set 1 in n116 and the acceleration time in n021 (acceleration time 2) and deceleration time in n022 (deceleration time 2) for stall prevention use.

6-7 Overtorque Detection Function

When an excessive load is applied to the equipment, the Inverter detects the overtorque condition through an increase in the output current.

n096	Overtorque Detection Function Selection 1	Register	0160 Hex	Changes during operation	No
Setting range	0 to 4	Unit of setting	1	Default setting	0

Set Values

Value	Description
0	Inverter does not monitor overtorque.
1	Inverter monitors overtorque only when speed is matched. It continues operation (issues warning) even after overtorque is detected.
2	Inverter monitors overtorque only when speed is matched. It discontinues operation (through protective function) when overtorque is detected.
3	Inverter always monitors overtorque during operation. It continues operation (issues warning) even after overtorque is detected.
4	Inverter always monitors overtorque during operation. It discontinues operation (through protective function) when overtorque is detected.

- Set n097 (overtorque detection function selection 2), n098 (overtorque detection level) and n099 (overtorque detection time) to enable the overtorque detection function. The Inverter will detect overtorque when the current is the same as or higher than the detection level is output for the preset detection time.
- Set a multi-function output (n057 to n059) to either of the following so that external overtorque detection output will be ON.
 - Set Value: 6 for overtorque detection (NO)
 - Set Value: 7 for overtorque detection (NC)

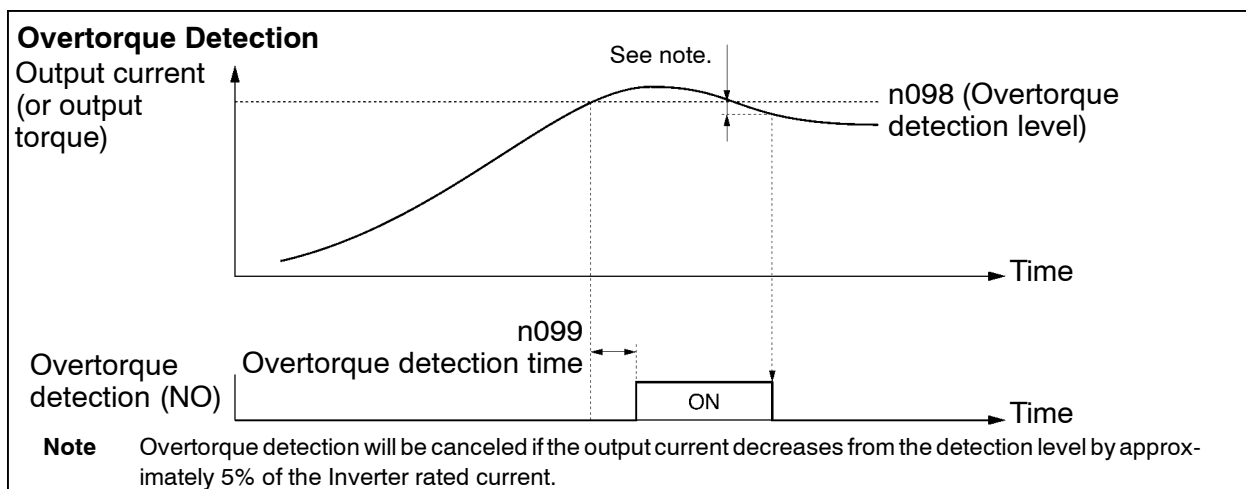

n097	Overtorque Detection Function Selection 2	Register	0161 Hex	Changes during operation	No
Setting range	0, 1	Unit of setting	1	Default setting	0

Set Values

Value	Description
0	Detects overtorque from output torque.
1	Detects overtorque from output current.

- Set n097 to the item used for overtorque detection.
- In V/f control mode, overtorque is detected through the output current of the Inverter regardless of the set value.

n098	Overtorque Detection Level	Register	0162 Hex	Changes during operation	No
Setting range	30 to 200 (%)	Unit of setting	1%	Default setting	160

Set Values

- Set n098 to the type of overtorque detection level.

To detect the level through the output torque, set the torque in percentage based on the rated motor torque as 100%.

To detect the level through the output current, set the current in percentage based on the rated current of the Inverter as 100%.

n099	Overtorque Detection Time	Register	0163 Hex	Changes during operation	No
Setting range	0.1 to 10.0 (s)	Unit of setting	0.1 s	Default setting	0.1

Set Values

- Set the overtorque detection time.
- The Inverter will detect overtorque when the current (or torque) the same as or higher than the detection level is output for the preset detection time.

6-8 Torque Compensation Function

This function increases the output torque of the Inverter by detecting an increase in the motor load.

n103	Torque Compensation Gain	Register	0167 Hex	Changes during operation	Yes
Setting range	0.0 to 2.5	Unit of setting	0.1	Default setting	1.0

Set Values

- The default setting does not need any changes in normal operation.
- Change the default setting in the following cases.
 - The wiring distance between the Inverter and motor is long:
Set the gain to a larger value.
 - The capacity of the motor is lower than the maximum applicable motor capacity of the Inverter:
Set the gain to a larger value.
 - The motor vibrates:
Set the gain to a smaller value.
- The torque compensation gain must be adjusted so that the output current at low speed will not exceed 50% of the rated output current of the Inverter, otherwise the Inverter may be damaged.

n104	Torque Compensation Primary Delay Time Constant	Register	0168 Hex	Changes during operation	No
Setting range	0.0 to 25.5 (s)	Unit of setting	0.1 s	Default setting	0.3 (see note)

Note The default value is 0.2 (s) with the Inverter set to vector control mode.

Set Values

- This parameter is used for adjusting the response of torque compensation.
- Normally, the default setting does not need to be changed.
- Adjust the parameter in the following cases.
 - The motor vibrates: Increase the set value.
 - The response of the motor is slow: Decrease the set value.

n105	Torque Compensation Core Loss	Register	0168 Hex	Changes during operation	No
Setting range	0.0 to 6,550 (W)	Unit of setting	0.1 W (see note 1)	Default setting	See note 2

Note 1. The value will be set in 0.1-W increments if the loss is less than 1,000 W and 1-W increments if the loss is 1,000 W or over.

Note 2. The default setting varies with the capacity of the Inverter model.

Set Values

- Set this value to the core loss of the motor in used.
- This parameter is valid in V/f control mode only.
- Normally, the default setting does not need to be changed.
- Set the value if the capacity of the motor does not coincide with the maximum applicable motor capacity of the Inverter.

6-9 Slip Compensation Function

The slip compensation function calculates the motor torque according to the output current, and sets gain to compensate for output frequency. This function is used to improve speed accuracy when operating with a load. It is mainly valid for V/f gain.

n106	Rated Motor Slip	Register	016A Hex	Changes during operation	Yes
Setting range	0.0 to 20.0 (Hz)	Unit of setting	0.1 Hz	Default setting	(see note)

Note The default setting varies with the capacity of the Inverter model.

Set Values

- Set the rated slip value of the motor in use.
- This parameter is used as a slip compensation constant.
- Calculate the rated motor slip value from the rated frequency (Hz) and rpm on the motor nameplate by using the following formula.

$$\text{Rated slip value (Hz)} = \text{Rated frequency (Hz)} - \frac{\text{Rated rpm} \times \text{Number of poles}}{120}$$

n111	Slip Compensation Gain	Register	016F Hex	Changes during operation	Yes
Setting range	0.0 to 2.5	Unit of setting	0.1	Default setting	0.0 (see note 1)

Note 1. If set to vector control mode, the default value will be 1.0.

Note 2. This parameter is disabled with the value set to 0.0.

Set Values

- Set the parameter to 1.0 first and check the operation of the Inverter. Then fine-tune the gain with 0.1-gain increments or decrements.

If the speed is lower than the target value, increase the set value.

If the speed is higher than the target value, decrease the set value.

n112	Slip Compensation Primary Delay Time	Register	0170 Hex	Changes during operation	No
Setting range	0.0 to 25.5 (s)	Unit of setting	0.1 s	Default setting	2.0 (see note)

Note If set to vector control mode, the default value will be 0.2.

Set Values

- This parameter is used for the response adjustment of the slip compensation function.
- The default setting does not need any changes in normal operation.
- Change the default setting in the following cases.

The motor vibrates: Set the value to a larger value.

The motor response is low: Set the value to a smaller value.

n113	Slip Compensation During Regeneration	Register	0171 Hex	Changes during operation	No
Setting range	0, 1	Unit of setting	1	Default setting	0

Set Values

Value	Description
0	Slip compensation function disabled during regeneration
1	Slip compensation function enabled during regeneration

- Select whether the slip compensation function is enabled or not, even during regeneration (i.e.: when regeneration energy is returning during deceleration, etc.).
- This parameter is only enabled in vector control mode. (In V/f control mode, the slip compensation function will be disabled during regeneration, regardless of the setting for this parameter.)

6-10 Other Functions

The following description provides information on the other functions and parameter settings of the Inverter.

Refer to *Section 7 Communications* for parameters used for communications.

6-10-1 Digital Operator Disconnection Error Detection

- This parameter setting is to select whether or not to detect Digital Operator connection errors.

n010	Operation Selection at Digital Operator Interruption	Register	010A Hex	Changes during operation	No
Setting range	0, 1	Unit of setting	1	Default setting	0

Set Values

Value	Description
0	The Digital Operator connection error is not detected (Nonfatal error)
1	The Digital Operator connection error is detected (Error output and the Inverter coasts to a stop)

6-10-2 Motor Protection Functions (n037 and n038)

- This parameter setting is for motor overload detection (OL1).

n037	Motor Protection Characteristics	Register	0125 Hex	Changes during operation	No
Setting range	0 to 2	Unit of setting	1	Default setting	0

Set Values

Value	Description
0	Protection characteristics for general-purpose induction motors
1	Protection characteristics for Inverter-dedicated motors
2	No protection

- This parameter is used to set the electric thermal characteristics of the motor to be connected.
- Set the parameter according to the motor.
- If a single Inverter is connected to more than one motor, set the parameter to 2 for no protection. The parameter is also disabled by setting n036 for rated motor current to 0.0. However, this is not recommended.

n038	Motor Protection Time	Register	0126 Hex	Changes during operation	No
Setting range	1 to 60 (min)	Unit of setting	1 min	Default setting	8

Set Values

- This parameter is used to set the electronic thermal protection constant of motor overload detection OL1.
- The default setting does not need any changes in normal operation.
- To set the parameter according to the characteristics of the motor, confirm the thermal time constant with the motor manufacturer and set the parameter with some margin. In other words, set the value a little shorter than the thermal time constant.
- To detect motor overloading more quickly, reduce the set value, provided that it does not cause any application problems.

6-10-3 Cooling Fan Operation Function (n039)

- This parameter is used to operate the cooling fan of the Inverter while the Inverter is turned ON or only while the Inverter is in operation.

n039	Cooling Fan Operation	Register	0127 Hex	Changes during operation	No
Setting range	0, 1	Unit of setting	1	Default setting	0

Set Values

Value	Description
0	The fan rotates only while the RUN command is input and for 1 minute after the Inverter stops operating.
1	The fan rotates while the Inverter is turned ON.

- This parameter is available only if the Inverter incorporates a cooling fan.
- If the operation frequency of the Inverter is low, the life of the fan can be prolonged by setting the parameter to 0.

6-10-4 Momentary Power Interruption Compensation (n081)

- The parameter specifies the processing that will be performed when a momentary power interruption occurs.

n081	Momentary Power Interruption Compensation	Register	0151 Hex	Changes during operation	No
Setting range	0 to 2	Unit of setting	1	Default setting	0

Set Values

Value	Description
0	Disabled. (An undervoltage fault will be detected when there is momentary power interruption for 15 ms or more.)
1	The Inverter will continue operating if power is restored within 0.5 s. (see note 1)
2	The Inverter will restart when power is restored. (see note 2)

Note 1. By setting n081 to 1, the Inverter will detect UV warning, turn OFF the output, and wait for power restoration for 0.5 s if a momentary power interruption occurs. If the power recovers within 0.5 s, the Inverter will restart after speed searching. If the momentary power interruption continues more than 0.5 s, the Inverter will detect UV1.

Note 2. By setting n081 to 2, the Inverter will detect UV warning, turn OFF the output, and wait for power restoration if a momentary power interruption occurs. When the power recovers, the Inverter will restart after speed searching.

6-10-5 Fault Retry (n082)

 **Caution** The Inverter may break if the fault retry function is used.

If the Inverter breaks, take the following measures:

Be sure to install a no-fuse breaker (NFB).

Provide the Inverter and peripheral machines with a sequence so that the machines will stop operating when the Inverter has an operational fault.

- The fault retry function automatically resets and restarts the Inverter in the case the Inverter has an overvoltage fault or an overcurrent fault during operation.
- In the case of any other fault, the protective function operates instantly and the fault retry function does not operate.
- This function is to be used only if the user does not want to interrupt the mechanical system, even if this function may damage the Inverter.
- Set a multi-function output (n057 to n059) to the following so that the fault retry signal will be output.

Set value: 14 for fault retries

n082	Number of Fault Retries	Register	0152 Hex	Changes during operation	No
Setting range	0 to 10	Unit of setting	1	Default setting	0

Set Values

- Set the number of fault retries required.
- The count of fault retries will be cleared in any of the following cases.
 - The Inverter is normal for 10 minutes continuously after the latest fault retry was made.
 - Power supply to the Inverter is interrupted.
 - A fault reset is input.

6-10-6 Frequency Jump Function (n083 to n086)

- The frequency jump function prevents the Inverter from generating frequencies that make the mechanical system resonate.
- The frequency jump function can be used effectively to set three dead bands of a frequency reference.

n083	Jump Frequency 1	Register	0153 Hex	Changes during operation	No
Setting range	0.00 to 400.0 (Hz)	Unit of setting	0.01 Hz	Default setting	0.00

n084	Jump Frequency 2	Register	0154 Hex	Changes during operation	No
Setting range	0.00 to 400.0 (Hz)	Unit of setting	0.01 Hz	Default setting	0.00

n085	Jump Frequency 3	Register	0155 Hex	Changes during operation	No
Setting range	0.00 to 400.0 (Hz)	Unit of setting	0.01 Hz	Default setting	0.00

n086	Jump Width	Register	0156 Hex	Changes during operation	No
Setting range	0.00 to 25.50 (Hz)	Unit of setting	0.01 Hz	Default setting	0.00

Set Values

- Set n083 through n085 for jump frequencies 1 through 3 to the central values of jumping frequencies.

- Values will be set in 0.01 -Hz increments if the frequency is less than 100 Hz and 0.1 -Hz increments if the frequency is 100 Hz or over.
- These values must satisfy the following condition.
 $n083 \geq n084 \geq n085$
- The value in n086 must be set for the jump width.
- This function is disabled with n086 set to 0.0.
- The operation of the Inverter within the dead bands is prohibited. While the Inverter is in acceleration or deceleration control, however, the Inverter does not jump the bands but changes the frequency smoothly.

Frequency Jump Function

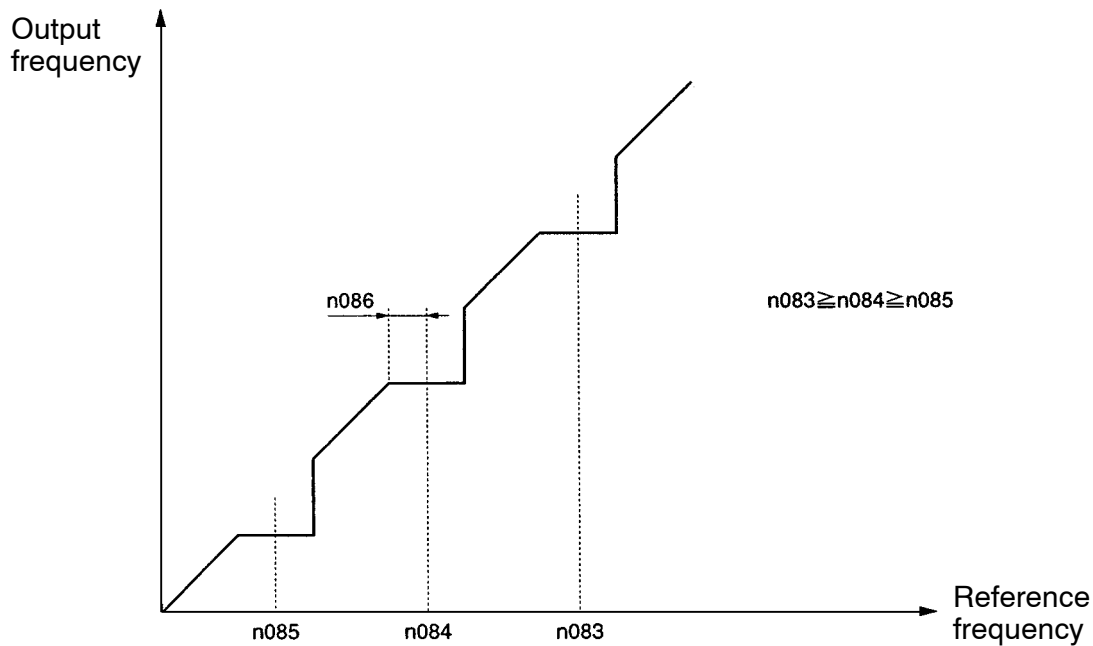

6-10-7 Accumulated Operating Time (n087, n088)

- The accumulated operating time function is provided for 5.5- and 7.5-kW Inverters only.
- This function calculates and stores in memory the Inverter’s accumulated operating time. The accumulated operating time that is saved can be checked (unit: 10h) by the “accumulated operating time” (U-13) of the multi-function monitor (MNTR indicator).
- Use this function in determining the maintenance schedule.

n087	Accumulated Operating Time	Register	0157 Hex	Changes during operation	No
Setting range	0, 1	Unit of setting	1	Default setting	0

Set Values

- Select the operation status to be accumulated.

Value	Description
0	Accumulate the Inverter's power-ON time (the time from when the power is turned ON until it is shut OFF).
1	Accumulate the Inverter's RUN time (the time that the RUN command is being input).

n088	Accumulated Operating Time Selection	Register	0158 Hex	Changes during operation	No
Setting range	0 to 6,550	Unit of setting	10 H	Default setting	0

- Set the initial value for the accumulated operating time with 10 hours set as 1. The accumulation will begin from the time that is set.

Note To clear (i.e., set to 0) the monitor value (U-13) for the accumulated operating time, set n088 to 0. The monitor value cannot be cleared by setting n001 (parameter write-prohibit selection/parameter initialization) to 8 or 9 (initialize).

6-10-8 Frequency Detection Function

- The 3G3MV has the following frequency detection functions.

Frequency Detection:

Detects that the frequency reference coincides with the output frequency.

Frequency Detection Levels 1 and 2:

Detects that the output frequency is the same as or higher or lower than the set value (frequency detection level) in n095.

- The multi-function outputs (n057 to n059) must be set for the frequency detection function.

■ Frequency Detection

- The multi-function outputs (n057 to n059) must be set to the following in order to issue an output indicating that the frequency reference and the output frequency agree.

Set value: 2 for frequency agree

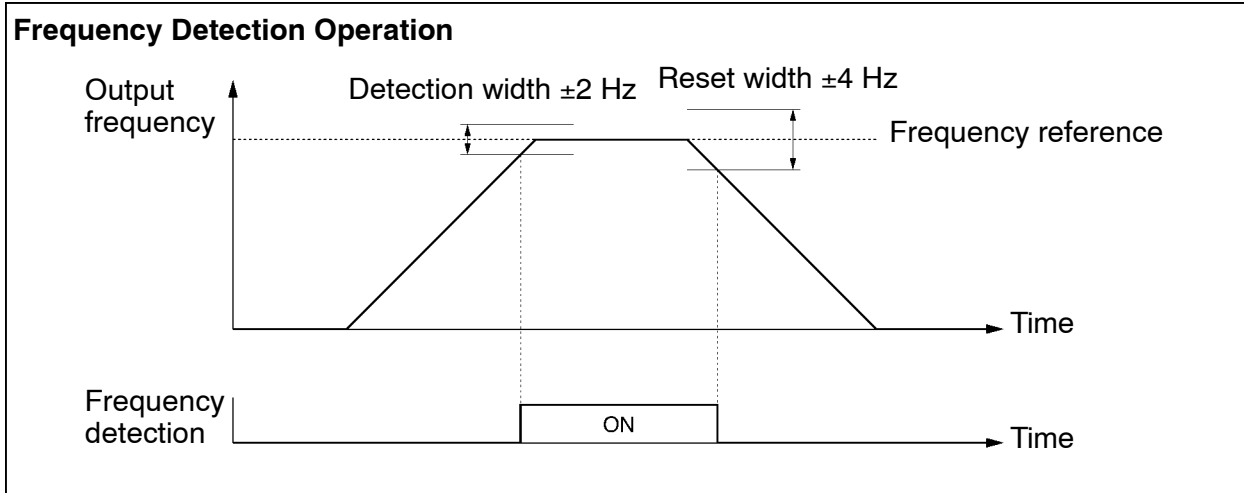

■ Frequency Detection Levels 1 and 2

- The parameters in n057 to n059 for multi-function output must be set for frequency detection output.

Set value: 4 for frequency detection level 1 (Output frequency □ n095)

Set value: 5 for frequency detection level 2 (Output frequency □ n095)

- Set the frequency detection level in n095.

n095	Frequency Detection Level	Register	015F Hex	Changes during operation	No
Setting range	0.00 to 400.0 (Hz)	Unit of setting	0.01 Hz	Default setting	0.00

Set Values

- Set the frequency to be detected.

- The value will be set in 0.01-Hz increments if the frequency is less than 100 Hz and 0.1-Hz increments if the frequency is 100 Hz or over.

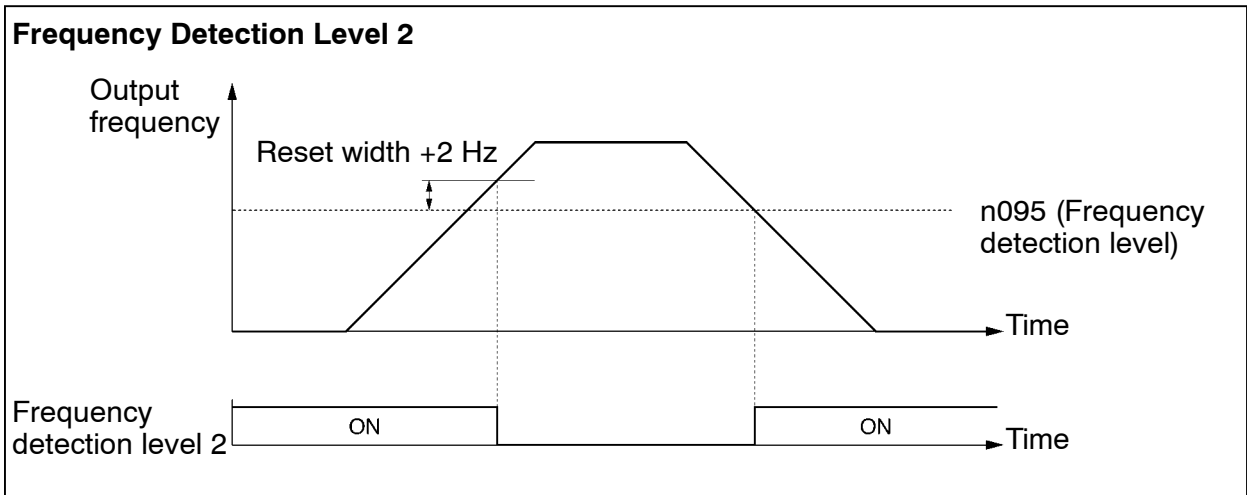
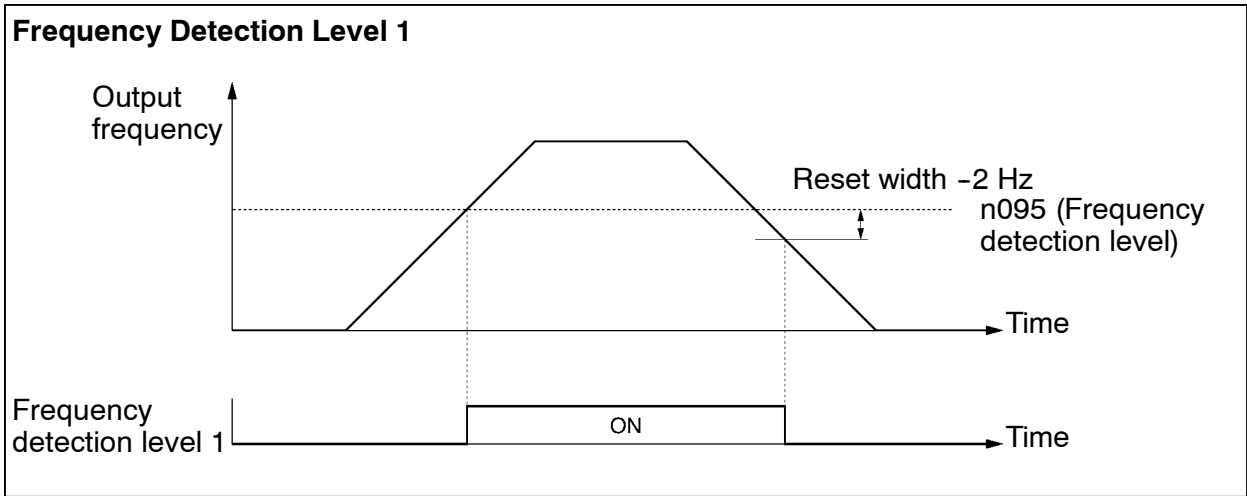

6-10-9 UP/DOWN Command Frequency Memory (n100)

- This function changes the reference frequency by turning the UP and DOWN commands ON and OFF.
- In order to use this function, set n056 for multi-function input 7 to 34. Then the multi-function input 6 (S6) and multi-function input 7 (S7) terminals are set as described below.
 - Multi-function input 6 (S6): UP command
 - Multi-function input 7 (S7): DOWN command
- The output frequency held by the UP/DOWN function will be stored in the memory if n100 for UP/DOWN frequency storage is set to 1.
- By setting n100 to 1, the frequency reference kept on hold for 5 s or more will be retained even after a power interruption, and operation will be restarted at this frequency the next time the RUN command is input.

- The stored output frequency will be cleared from the memory if n100 is set to 0. The retained frequency is initialized if n001 for parameter initialization is set to 8 or 9.

Note While this function is used, frequency references can only be used in remote mode with the UP/DOWN command or inching frequency command. All multi-step speed references are disabled.

n100	UP/DOWN Frequency Selection	Register	0164 Hex	Changes during operation	No
Setting range	0, 1	Unit of setting	1	Default setting	0

Set Values

Value	Description
0	The frequency on hold is not retained.
1	The frequency on hold for 5 s or more is retained.

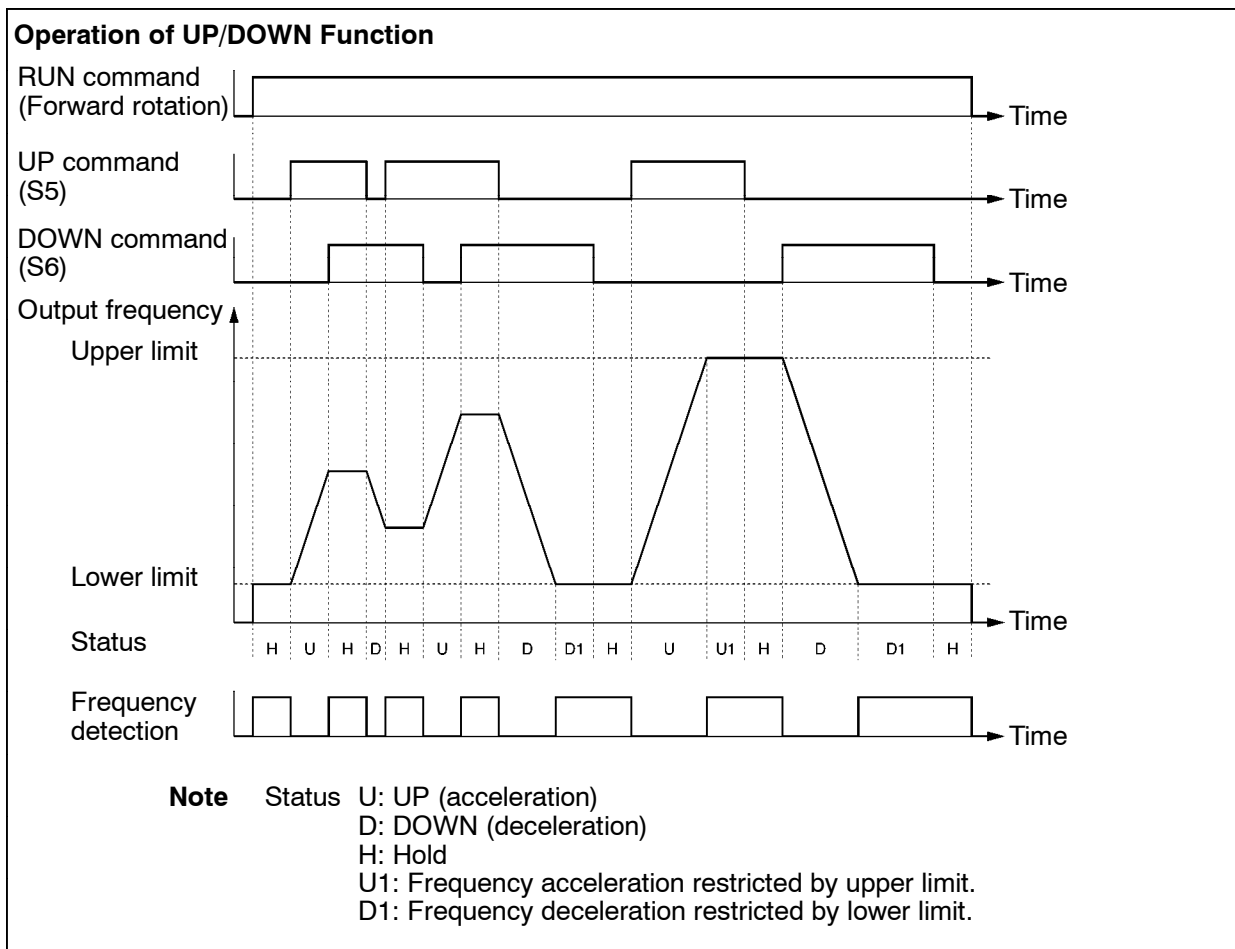

- The following ON/OFF combinations of UP and DOWN commands are possible.

Command	Acceleration	Deceleration	Hold	Hold
S6 (UP command)	ON	OFF	OFF	ON
S7 (DOWN command)	OFF	ON	OFF	ON

- With the UP/DOWN function used, the output frequency has the following restrictions for upper and lower limits.

Upper limit: The maximum frequency in n011 or the frequency reference upper limit in n033, whichever is smaller.

Lower limit: The minimum output frequency in n016 or frequency reference lower limit in n034, whichever is smaller.

- When the RUN command for forward or reverse rotation is input, the Inverter will start operating at the lower limit regardless of whether the UP/DOWN command is input or not.
- When the UP/DOWN function and inching frequency command are both assigned to multi-function inputs, an inching frequency command input will have the highest priority.
- If n100 for UP/DOWN frequency storage is set to 1, the output frequency held by the UP/DOWN function for 5 s or more will be stored in the memory. The output frequency will be held by the UP/DOWN function when both UP and DOWN commands are ON or OFF together.

6-10-10 Input Open-phase Detection (n166, n167)

- The input open-phase detection function is provided for 5.5- and 7.5-kW Inverters only.
- This function detects the occurrence of an input power supply open phase. The open phase is detected by means of fluctuations in the main circuit DC voltage, enabling detection of power supply voltage fluctuations and imbalances, decreasing values due to ageing of the main circuit capacitor, and so on, in the same way.
- If the fluctuations in the main circuit DC voltage exceed the input open-phase detection level (n166), and persist at this level for longer than the input open-phase detection time (n167), a main-circuit voltage fault (PF) will be detected.

n166	Input Open-phase Detection Level	Register	01A6 Hex	Changes during operation	No
Setting range	0 to 100	Unit of setting	1 %	Default setting	0
n167	Input Open-phase Detection Time	Register	01A7 Hex	Changes during operation	No
Setting range	0 to 255	Unit of setting	1 s	Default setting	0

Set Values

- For the input open-phase detection level (n166), set the main-circuit DC voltage fluctuation level for detecting an input open phase. Set the level as a percentage, as follows:
 - 200-V-class Inverters: Take 400 V as 100%.
 - 400-V-class Inverters: Take 800 V as 100%.
- For the input open-phase detection time (n167), set the time (in seconds) for detecting an input open phase.

Note 1. The following values are recommended for detecting an input open phase:
n166 = 7 (%); n167 = 10 (s)

Note 2. If either n166 or n167 is set to 0, the input open-phase detection function will be disabled.

6-10-11 Output Open-phase Detection (n168, n169)

- The output open-phase detection function is provided for 5.5-kW and 7.5-kW Inverters only.
- This function detects the occurrence of an output terminal open phase. The detection is performed at the current flowing at each output phase.
- If the current in any of the Inverter output phases becomes less than the output open-phase detection level (n168) and persists at this level for longer than the output open-phase detection time (n169), an output open-phase fault (LF) will be detected.

n168	Output Open-phase Detection Level	Register	01A8 Hex	Changes during operation	No
Setting range	0 to 100	Unit of setting	1 %	Default setting	0
n169	Output Open-phase Detection Time	Register	01A9 Hex	Changes during operation	No
Setting range	0.0 to 2.0	Unit of setting	0.1 s	Default setting	0.0

Set Values

- For the output open-phase detection level (n168), set the current for detecting an output open phase. Make the setting as a percentage, taking the Inverter’s rated output current as 100%.
- For the output open-phase detection time (n169), set the time in seconds for detecting an output open phase.

Note 1. The following values are recommended for detecting an output open phase:
n168 = 5 (%); n169 = 0.2 (s)

Note 2. If either n168 or n169 is set to 0, the output open-phase detection function will be disabled.

Note 3. If the applicable motor capacity is small in relation to the Inverter capacity, it may cause errors in the output open-phase detection. To prevent this from occurring, lower the output open-phase detection level to match the motor capacity.

6-10-12 Fault Log (n178)

- The 3G3MV stores information on the four most recent faults.
- The latest record is displayed. By pressing the Increment Key, the previous record is displayed. A maximum of four records can be checked.
- The details of the information are the same as that obtained from the multi-function monitor U-09.

n178	Fault Log	Register	01B2 Hex	Changes during operation	---
Setting range	---	Unit of setting	---	Default setting	---

Note The information is read only.

Display Example

- Fault display

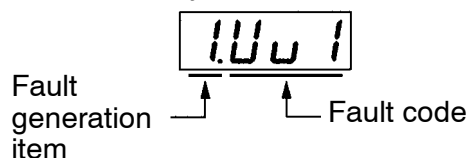

- No fault stored



- To clear the faultlog, set n001 for parameter write-prohibit selection/parameter initialization to 6.

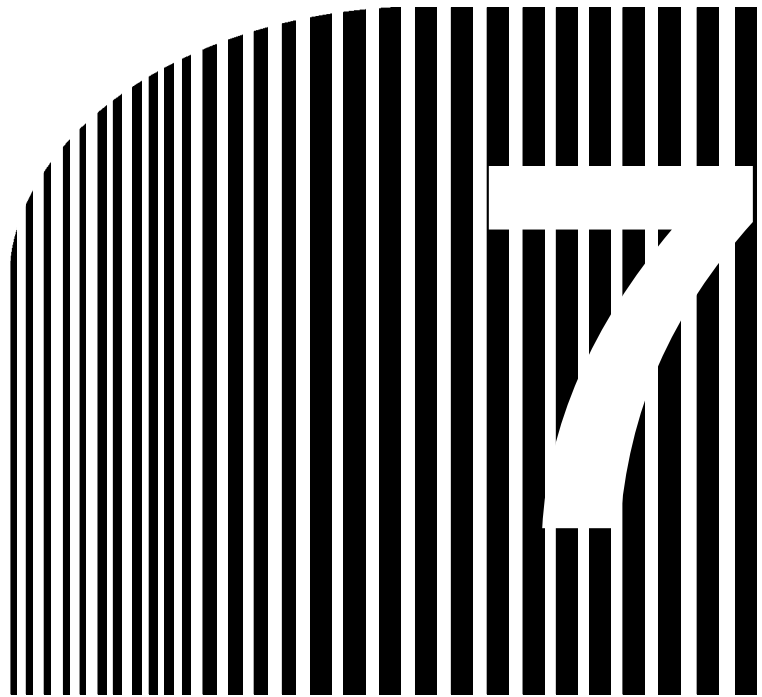

Chapter 7

• Communications •

- 7-1 Inverter Settings
- 7-2 Message Communications Basic Formats
- 7-3 DSR Message and Response
- 7-4 Enter Command
- 7-5 Setting the Communications Data
- 7-6 Register Number Allocations in Detail
- 7-7 Communications Error Codes
- 7-8 Self-diagnostic Test
- 7-9 Communications with Programmable Controller

The 3G3MV Inverter has standard RS-422/485 and optional CompoBus/D communications functions. This section provides information on how to communicate over RS-422/485. For CompoBus/D communications in detail, refer to the *3G3MV-PDRT1-SINV CompoBus/D Communications Unit User's Manual (I529)*.

It is possible to control the Inverter, give frequency references, monitor the Inverter status, and read and write parameters through communications. A maximum of 32 Inverter Units can be connected and used as a simple network system.

Note The RS-422/485 communications of the 3G3MV Inverter conform to the MODBUS Communications Protocol and this protocol cannot be used together with CompoBus/D communications protocol or any other communications protocol. Only 3G3MV-Series products can be connected as Slaves.

(The MODBUS Communications Protocol is a trademark of AEG Schneider Automation.)

7-1 Inverter Settings

7-1-1 Setting the Communications Conditions

■ Communications Time-over Detection Selection (n151)

- This parameter is used for monitoring the communications system.
- The set value in the parameter determines whether communications time-over detection will be performed with “CE” displayed if there is an interval of more than 2 s between normal communications. The method to process the detected communications time-over is also determined according to the set value in the parameter.
- When a control signal (the RUN command, forward/reverse rotation command, or an external fault signal) is input into the Inverter through communications, be sure to set n151 to 0, 1, or 2. Then the system will stop in the case of a time-over detection. If there is a communications failure, no control input will be operable. It will be, however, impossible to stop the Inverter if n151 is to 4 or 3. Use a host program that monitors how the Inverter handles all control input signals, for example, so that there will be no interval of more than 2 s between communications.

n151	RS-422/485 Communications Time-over Detection Selection	Register	0197 Hex	Changes during operation	No
Setting range	0 to 4	Unit of setting	1	Default setting	0

Set Values

Value	Description
0	Detects a time-over and fatal error and coasts to a stop (see note 1)
1	Detects a time-over and fatal error and decelerates to a stop in deceleration time 1 (see note 1)
2	Detects a time-over and fatal error and decelerates to a stop in deceleration time 2 (see note 1)
3	Detects a time-over and nonfatal error warning and continues operating. The warning is canceled when the communications return to normal. (see note 2)
4	No time-over is detected.

Note 1. The fatal error is canceled with error reset input.

Note 2. The nonfatal error warning is canceled when the communications returns to normal.

■ Communications Frequency Reference/Display Unit Selection (n152)

- Set this parameter to the unit of frequency reference and frequency-related values to be set or monitored through communications.
- This unit is for communications use only and independent from the units of setting made through the Digital Operator.

n152	RS-422/485 Communications Frequency Reference/Display Unit Selection	Register	0198 Hex	Changes during operation	No
Setting range	0 to 3	Unit of setting	1	Default setting	0

Set Values

Value	Description
0	0.1 Hz
1	0.01 Hz
2	Converted value based on 30,000 as max. frequency
3	0.1% (Max. frequency: 100%)

Note Communications data after the above conversion is hexadecimal.
 For example, if the frequency is 60 Hz and the unit of setting is 0.01 Hz, the converted value is obtained as follows:
 $60/0.01 = 6000 = 1770 \text{ Hex}$

■ **Slave Address (n153)**

- Set this parameter to the Slave address (Slave unit number) for communications.
- If more than one Inverter is connected as a Slave, make sure that there will be no Slave address duplication.

n153	RS-422/485 Communications Slave Address	Register	0199 Hex	Changes during operation	No
Setting range	00 to 32	Unit of setting	1	Default setting	00

Set Values

Value	Description
00	Only receives broadcast messages from the Master (see note)
01 to 32	Slave address

Note Address 00 is for broadcast purposes only. Do not set the Slave to this address, otherwise the Slave will not communicate.

■ **Communications Baud Rate and Parity Selection (n154 and n155)**

- Set the baud rate and parity according to the communications conditions of the Master.

n154	RS-422/485 Baud Rate Selection	Register	019A Hex	Changes during operation	No
Setting range	0 to 3	Unit of setting	1	Default setting	2

Set Values

Value	Description
0	2,400 bps
1	4,800 bps
2	9,600 bps
3	19,200 bps

n155	RS-422/485 Parity Selection	Register	019B Hex	Changes during operation	No
Setting range	0 to 2	Unit of setting	1	Default setting	0

Set Values

Value	Description
0	Even
1	Odd
2	No parity

In normal serial communications, data is configured in single bytes, and messages are created by stringing together multiple bytes of data. The parity check described here sets the check for each byte of data. Set the parity check method that is required by the Master.

Note The entire message is checked by a separate check code called “CRC-16,” so the communications data will be checked even if no special parity check is performed.

■ **Send Wait Time Setting (n156)**

- Set this parameter to an awaiting period for returning a response after the DSR (data-send-request) message is received from the Master.

n156	RS-422/485 Send Wait Time	Register	019C Hex	Changes during operation	No
Setting range	10 to 65 (ms)	Unit of setting	1 ms	Default setting	10

Set Values

- When the DSR message is received from the Master, the Inverter must wait for a communications time of 24-bit length plus the set value in n156 before returning a response.

Set this value according to the response time of the Master.

■ **RTS Control Selection (n157)**

- Select whether or not to enable the RTS (request-to-send) communications control function.

- This function can be disabled (i.e., set to “1”) only when a 1-to-1 Master/Slave configuration is used in RS-422 communications. When multiple Slaves are used for RS-422, or whenever RS-485 communications are used, it is necessary to set “0” (enable RTS control).

n157	RS-422/485 RTS Control Selection	Register	019D Hex	Changes during operation	No
Setting range	0, 1	Unit of setting	1	Default setting	0

Set Values

Value	Description
0	RTS control disabled
1	RTS control enabled (available to 1-to-1 RS-422 communications only)

7-1-2 RUN Command Selection (n003)

- Select the method to input the RUN or STOP command into the Inverter.
- This parameter is enabled in remote mode only. The Inverter in local mode accepts the RUN command only through key sequences on the Digital Operator.

n003	Operation Command Selection	Register	0103 Hex	Changes during operation	No
Setting range	0 to 3	Unit of setting	1	Default setting	0

Set Values

Value	Description
0	The RUN Key and STOP/RESET Key on the Digital Operator are enabled.
1	Multi-function input terminals are enabled in 2- or 3-wire sequence.
2	RS-422/485 communications are enabled.
3	Input from the optional CompoBus/D Communications Unit is enabled.

Note 1. To input the RUN command through RS-422/485 communications, set this parameter to 2. Then the RUN command only through RS-422/485 communications will be enabled.

Note 2. The RUN command can be input through RS-422/485 with multi-function input settings as well. For details, refer to 7-1-4 *Setting the Multi-function Inputs*.

7-1-3 Frequency Reference Input Selection (n004)

- Select the method to input the frequency reference into the Inverter in remote mode.

- Ten methods can be used to input the frequency reference in remote mode. Select the ideal method according to the application.

n004	Frequency Reference Selection	Register	0104 Hex	Changes during operation	No
Setting range	0 to 8	Unit of setting	1	Default setting	0

Set Values

Value	Description
0	The FREQUENCY adjuster on the Digital Operator is enabled.
1	Frequency reference 1 (024) is enabled.
2	Frequency reference control terminal for 0- to 10-V voltage input is enabled.
3	Frequency reference control terminal for 4- to 20-mA current input is enabled.
4	Frequency reference control terminal for 0- to 20-mA current input is enabled.
5	Pulse train reference control terminal is enabled.
6	Frequency reference through communications is enabled.
7	Multi-function analog voltage for 0- to 10-V input is enabled. Used only if two analog inputs are required in PID control.
8	Multi-function analog current for 4- to 20-mA input is enabled. Used only if two analog inputs are required in PID control.
9	Frequency reference through option (CompoBus/D communications) is enabled.

Note 1. To input the frequency reference through RS-422/485 communications, set this parameter to 6. Then the frequency reference only through RS-422/485 communications will be enabled.

Note 2. The frequency reference can be input through RS-422/485 with multi-function input settings as well. For details, refer to *7-1-4 Setting the Multi-function Inputs*.

7-1-4 Setting the Multi-function Inputs (n050 to n056)

- In addition to the methods described above, the RUN command and frequency reference can be input through RS-422/485 communications by setting the value 18 in any one of the parameters from n050 to n056 (multi-function input).
- Subsequently, the following operations are selectable in remote mode.

When the function-set input terminal is OFF, the RUN command will be executed according to the setting in n003 (RUN command selection) and the frequency reference will be executed according to the setting in n004 (frequency reference selection).

When the function-set input terminal is ON, the Inverter will operate according to the RUN command and frequency reference through RS-422/485 communications.

n050	Multi-function input 1 (S1)	Register	0132 Hex	Changes during operation	No
Setting range	1 to 25	Unit of setting	1	Default setting	1
n051	Multi-function input 2 (S2)	Register	0133 Hex	Changes during operation	No
Setting range	1 to 25	Unit of setting	1	Default setting	2
n052	Multi-function input 3 (S3)	Register	0134 Hex	Changes during operation	No
Setting range	1 to 25	Unit of setting	1	Default setting	3
n053	Multi-function input 4 (S4)	Register	0135 Hex	Changes during operation	No
Setting range	1 to 25	Unit of setting	1	Default setting	5
n054	Multi-function input 5 (S5)	Register	0136 Hex	Changes during operation	No
Setting range	1 to 25	Unit of setting	1	Default setting	6
n055	Multi-function input 6 (S6)	Register	0137 Hex	Changes during operation	No
Setting range	1 to 25	Unit of setting	1	Default setting	7
n056	Multi-function input 7 (S7)	Register	0138 Hex	Changes during operation	No
Setting range	1 to 25, 34, and 35	Unit of setting	1	Default setting	10

Using input signals (n050 to n056)

Multi-function input terminals

Setting	Name	Description
18	Communication/control circuit terminal selection (Comm/Terminal change over)	Run command from communication - from serial comm. card if it is connected¹⁾ , otherwise MEMOBUS comm. - and frequency reference (n004= 0 to 8) are effective if multi-function inout terminal for this setting is "1" (register no. 0001H, 0002H). Run command in LOCAL/REMOTE mode (n003=0,1) and frequency reference (n004=0 to 8) are effective if "0". ¹⁾ new from s/w 010024
26	Inverter overheating pre-alarm OH3	"OH3" is displayed (blinking) on the digital operator by signal input.
27	Accel/Decel time select 2	2 Multi-func. inputs (two from n050 to n056) are to set as "11" (Accel./Decel time select 1) and "27" to switch among 4 accel./decel. times. (n019 to n022; n041 to n044)

7-2 Message Communications Basic Formats

The following description provides information on the format of message data (DSR and response data).

Message communications of the Inverter conform to the MODBUS Communications Protocol, which does not require message start and end processing.

(The MODBUS Communications Protocol is a trademark of AEG Schneider Automation.)

■ Communications Format

- The following format is used for message data communications.
- Message data consists of a Slave address, function code, communications data, and error check block.

Message data (DSR message and response)

Slave address 1 byte	Function code 1 byte	Communications data	Error check block 2 bytes
-------------------------	-------------------------	---------------------	------------------------------

■ Message Interval

- When the Inverter receives a DSR message from the Master, the Inverter waits for a period that is equivalent to 24 bits in length and a Send Wait Time set in n156. Then the Inverter will return a response. Set n156 according to the Master's processing time or the timing adjustment.
- When the Master issues the next message after receiving the response from the Inverter, the Master must wait for a 24-bit period plus another period of at least 10 ms.

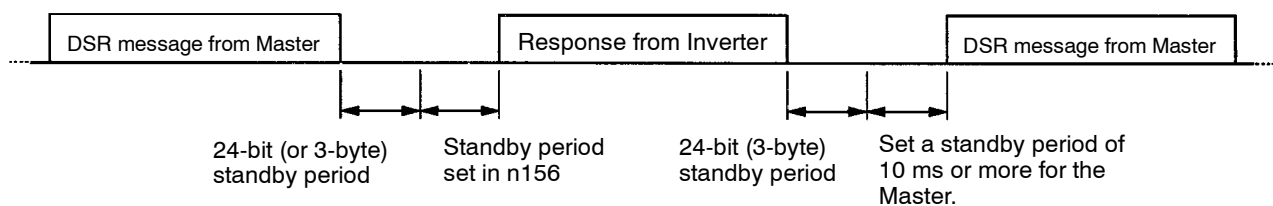

■ **Message Data Configuration**

- The communications message is configured entirely of hexadecimal data. (ASCII and FINS are not used.)
- Communications data is divided into the four areas shown in the following table.

Data name	Description
Slave address	Set the Slave address (the set value in n153) of the Inverter, to which the DSR message is sent. The Slave address must be within a range from 00 to 32 (00 to 20 Hex).
Function code	A command giving instructions of the details of processing to the Inverter. Example: Data read (03 Hex) and data write (10 Hex)
Communications data	Data attached to the command. Example: The register number of read start data and the number of registers of read data
Error check	CRC-16 check code for checking the reliability of the message data.

Note In the above communications, the default is -1 (65535) and the LSB (least-significant byte) is converted as MSB (most-significant byte) (in the opposite direction). The CRC-16 check is automatically performed by using the protocol macro function of OMRON’s SYSMAC CS1-series or C200HX/HG/HE Programmable Controllers.

■ **Slave Address**

- The Master can communicate with a maximum of 32 Slaves over RS-422/485. A unique Slave address is allocated to each Slave (Inverter) for communications.
- Slave addresses are within a range from 00 to 32 (00 through 20 Hex). If a DSR message is issued to Slave address 00, the message will be a broadcast message.

Note The broadcast message is addressed to all Slaves. Only the RUN command (register 0001 Hex) and frequency command (register 0002 Hex) can be written to the message. The Inverter receiving this message does not return a response regardless of whether or not the message is received properly. Therefore, for measures against communications errors, the monitor function of the Inverter should be used for checking the reception of broadcast messages.

■ **Function Code**

- The function code is a command giving instructions of the details of processing to the Inverter.

- The following three functions codes are available.

Function code	Command name	Description
03 Hex	Data read	Reads the data of the specified register number. Consecutive data of a maximum of 16 words (32 bytes) can be read.
08 Hex	Loop-back test	The DSR message is returned as a response. This command is used for checking the status of communications.
10 Hex	Data write	The attached data in the format is written to the specified register number. Consecutive data of a maximum of 16 words (32 bytes) can be written.

Note 1. Do not use any code other than the above, otherwise the Inverter will detect a communications error and return an error message.

Note 2. The Inverter uses the same function code for the response. If an error occurs, however, the MSB of the function code will be set to 1. For example, if an error occurs in a DSR message with function code 03, the function code of the response will be 83.

■ Communications Data

- Communications data is attached to the command. The contents and its arrangement of communications data vary with the function code. For details, refer to 7-3 DSR Message and Response.

■ Error Check

- The CRC-16 check code is the remainder (16 bits) when all of the message blocks from the Slave address to the final communications data are connected in series, as shown in the following diagram, and this data is divided by a fixed 17-digit binary number (1 1000 0000 0000 0101).

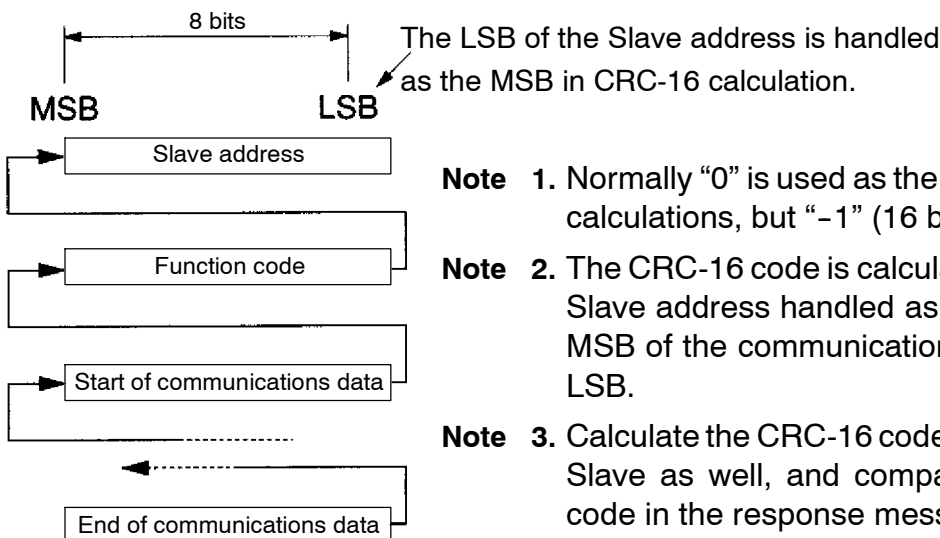

Note 1. Normally “0” is used as the initial value for CRC-16 calculations, but “-1” (16 bits all “1”) is used here.

Note 2. The CRC-16 code is calculated with the LSB of the Slave address handled as the MSB, and the final MSB of the communications data handled as the LSB.

Note 3. Calculate the CRC-16 code for responses from the Slave as well, and compare it with the CRC-16 code in the response message.

7-3 DSR Message and Response

The following description provides information on how to set DSR messages and what details are returned as responses. Each DSR message or response is divided into 8-bit blocks. Therefore, data must be set in 8-bit blocks for communications.

7-3-1 Data Read (Function Code: 03 Hex)

■ Settings and Response

- To read data (such as control I/O status data, monitor item data, or parameter set value data) from the Inverter, issue the following DSR message.
- Data read is a maximum of 16 words in length (i.e., data of 32 bytes from 16 registers) per DSR message.
- The register number is allocated to each function item, such as control I/O, monitor item, and parameter functions. The register number of each parameter is indicated wherever the parameter is explained in this manual and in *Section 10 List of Parameters*. For register numbers other than those of parameters, refer to *7-6 Register Number Allocations in Details*.

Note 1. A parameter corresponds to one register (one word), so the “number of registers of read data” indicates the number of parameters to be read (i.e., the number of consecutive registers beginning with the first register number).

Note 2. The “number of bytes of attached data” indicates the number of bytes of data read from the registers attached from that point onwards. The number of registers must equal the number of bytes divided by two.

● DSR Message

Byte No.	Data
1	Slave address
2	Function code (03 Hex)
3	Register No. of read start data
4	
5	No. of registers of read data (max. 16)
6	
7	CRC-16 check
8	

● Response

Normal

Byte No.	Data	
1	Slave address	
2	Function code (03 Hex)	
3	No. of bytes of attached data	
4	Data of start register	MS B
5		LSB
6	Data of next register	MSB
7		LSB
8	Data of next register	MSB
9		LSB
:	:	:
n-1	CRC-16 check	
n		

Error

Byte No.	Data	
1	Slave address	
2	Function code (83 Hex)	
3	Error code	
4	CRC-16 check	
5		

Note When an error occurs, the MSB of the function code will be set to 1.

■ Example of Data Read

- In the following example, four-register data (status signal data) is read from register 0020 Hex of the Inverter with a Slave address of 02.

● DSR Message

Byte No.	Data	Data example (Hex)
1	Slave address	02
2	Function code	03
3	Register No. of read start data	00
4		20
5	No. of registers of read data	00
6		04
7	CRC-16 check	45
8		F0

● Response

Normal

Byte No.	Data	Data example (Hex)	
1	Slave address	02	
2	Function code	03	
3	No. of bytes of attached data	08	
4	Data in register No. 0020	MS B	00
5		LSB	65
6	Data in register No. 0021	MSB	00
7		LSB	00
8	Data in register No. 0022	MSB	00
9		LSB	00
10	Data in register No. 0023	MSB	01
11		LSB	F4
12	CRC-16 check		AF
13			82

Error

Byte No.	Data	Data example (Hex)
1	Slave address	02
2	Function code	83
3	Error code	03
4	CRC-16 check	F1
5		31

7-3-2 Data Write/Broadcast Data Write (Function Code: 10 Hex)

■ Settings and Response

- To write data to the Inverter, such as control I/O and parameter set value data, issue the following DSR message.
- Consecutive data of a maximum of 16 words (32 bytes for 16 registers) can be written per DSR message.
- The register number is allocated to each function item, such as control I/O and parameter functions. The register number of each parameter is indicated wherever the parameter is explained in this manual and in *Section 10 List of Parameters*. For register numbers other than those of parameters, refer to *7-6 Register Number Allocations in Details*.

● DSR Message

Byte No.	Data	
1	Slave address	
2	Function code (10 Hex)	
3	Register No. of write start data	
4		
5	No. of registers of write data (max. 16)	
6		
7	Data of start register	
8	Data of next register	MSB
9		LSB
10	Data of next register	MSB
11		LSB
12	Data of next register	MSB
13		LSB
:	:	:
n-1	CRC-16 check	
n		

● Response

Normal

Byte No.	Data	
1	Slave address	
2	Function code (10 Hex)	
3	Register No. of write start data	MS B
4		LSB
5	No. of registers of write data	MSB
6		LSB
7	CRC-16 check	
8		

Error

Byte No.	Data	
1	Slave address	
2	Function code (90 Hex)	
3	Error code	
4	CRC-16 check	
5		

Note 1. When an error occurs, the MSB of the function code will be set to 1.

Note 2. A broadcast message uses the same DSR message format. The Slave address is, however, always set to 00 and only register 0001 Hex (the RUN command) and register number 0002 Hex (the frequency reference) can be written.

■ Example of Data Read

• In the following example, two-register data (the RUN command) is written from register 0002 Hex of the Inverter with a Slave address of 01.

● DSR Message

Byte No.	Data	Data example (Hex)
1	Slave address	01
2	Function code	10
3	Register No. of write start data	00
4		01
5	No. of registers of write data	00
6		02

Byte No.	Data	Data example (Hex)
7	Data of start register	04
8	Data in register No. 0001	MSB
9		LSB
10	Data in register No. 0002	MSB
11		LSB
12	CRC-16 check	63
13		39

● Response

Normal

Byte No.	Data	Data example (Hex)
1	Slave address	01
2	Function code	10
3	Register No. of write start data	00
4		01
5	No. of registers of write data	00
6		02
7	CRC-16 check	10
8		08

Error

Byte No.	Data	Data example (Hex)
1	Slave address	01
2	Function code	90
3	Error code	02
4	CRC-16 check	DC
5		C1

7-3-3 Loop-back Test (Function Code: 08 Hex)

■ Settings and Response

- The DSR message from the Master is returned as a response. The Inverter does not retrieve or process this data.

- The DSR message or normal response for loop-back test use is divided into 8-byte blocks as shown below. Any data can be set as test data 1 or 2 provided that the number of data items remains changed.
- This command is used for checking the status of communications or for dummy communications without detecting any communications time-over.

• DSR Message

Byte No.	Data
1	Slave address
2	Function code (08 Hex)
3	Test data 1
4	
5	Test data 2
6	
7	CRC-16 check
8	

• Response

Normal

Byte No.	Data
1	Slave address
2	Function code (08 Hex)
3	Test data 1
4	
5	Test data 2
6	
7	CRC-16 check
8	

Error

Byte No.	Data
1	Slave address
2	Function code (88 Hex)
3	Error code
4	CRC-16 check
5	

Note When an error occurs, the MSB of the function code will be set to 1.

■ **Example of Loop-back Test**

- In the following example, a loop-back test is conducted on the Inverter with a Slave address of 01.

● **DSR Message**

Byte No.	Data	Data example (Hex)
1	Slave address	01
2	Function code	08
3	Test data 1	00
4		00
5	Test data 2	A5
6		37
7	CRC-16 check	DA
8		8D

● **Response**

Normal

Byte No.	Data	Data example (Hex)
1	Slave address	01
2	Function code	08
3	Test data 1	00
4		00
5	Test data 2	A5
6		37
7	CRC-16 check	DA
8		8D

Error

Byte No.	Data	Data example (Hex)
1	Slave address	01
2	Function code	88
3	Error code	01
4	CRC-16 check	86
5		50

7-4 Enter Command

The Enter command is used for copying parameter set values that have been written through communications in and after register 0101 Hex of the RAM area to the EEPROM of the Inverter. This is done so that the EEPROM can maintain the parameter set values.

By issuing a DSR message to write data, the data is written to the RAM area of the Inverter. This data will be lost when the Inverter is turned OFF. Issue the Enter command to store in the EEPROM of the Inverter the parameter set value that has been written through communications.

Note The Enter command is not accepted while the Inverter is running. Be sure to issue the Enter command while the Inverter is not running.

■ DSR Message of Enter Command

- The Enter command is issued in response to the DSR message (with a function code of 10 Hex) to write data.
- By writing data 0000 Hex to be sent to register 0900 Hex, the Inverter copies to the EEPROM all parameter set values that the Inverter has received.

Note 1. Only the parameter constants (in and after register 0101 Hex) are stored in the EEPROM with the Enter command.

The RUN command (in register No. 0001 Hex) is in the RAM area. The frequency reference (in register 0002 Hex) or any other data in registers with a number up to 003D Hex is also in the RAM area. Therefore, the EEPROM does not store these parameters.

Note 2. Data can be written to the EEPROM a maximum of approximately 100,000 times. Therefore, be sure to reduce the number of Enter commands sent as much as possible.

7-5 Setting the Communications Data

The following description provides information on how to convert the register data (such as monitor value or parameter set value data) in the communications data block of the message data (such as DSR and response data).

■ Converting the Register Data

- The data in each register is sent as 2-byte data.
- The data in each register is processed under the following rules and sent in hexadecimal.
- **The data is converted to a hexadecimal value based on the minimum unit of setting of each register as 1.**

If the frequency reference is 60 Hz and the minimum unit of setting will be 0.01 Hz, the data will be converted as follows:

$$60 \text{ (Hz)} / 0.01 \text{ (Hz)} = 6000 = 1770 \text{ Hex}$$

Note 1. The minimum unit of setting of each parameter is indicated whenever the parameter is explained in this manual and in *Section 10 List of Parameters*. For registers other than those of parameters, refer to *7-6 Register Number Allocations in Details*.

Note 2. The minimum unit of setting of frequency reference data or frequency monitor data is determined by n152 (register 0198 Hex: RS-422/485 communications frequency reference/monitor unit selection). The unit of setting of each of the three registers below is determined by the set value in n152. For the units of setting of these constants, refer to the *List of Parameters*. The set value in n152 has nothing to do with frequency data items set as parameter constants (e.g., frequency references 1 through 16, inching frequency reference, maximum frequency, minimum output frequency, jump frequency).

• Monitor Items

Register 0023: Frequency reference monitor

Register 0024: Output frequency monitor

• Communications-dedicated Register

Register 0002: Frequency reference

In spite of the set value in n152, however, set the maximum frequency to 3000 when the frequency reference is executed with a broadcast message. In this case, the Inverter rounds off any value less than 0.01 Hz.

Note 3. There are parameters that make setting unit changes when the values are increased with the Digital Operator. The smaller units are, however, used for communications in such cases. For example, the value in n083 (register 0153 Hex: jump frequency 1) will be set in 0.01-Hz increments if the frequency is less than 100 Hz and 0.1-Hz increments if the frequency is 100 Hz or over. The value 0.01 Hz is always 1 Hex for communications.

If the jump frequency is 100.0 Hz, the minimum unit of setting will be 0.01 Hz and the data will be converted as follows:

$$100.0 \text{ (Hz)} / 0.01 \text{ (Hz)} = 10000 = 2710 \text{ Hex}$$

● **Negative Values Expressed in 2's Complements**

If the frequency reference bias in n061 is -100%, the minimum unit of setting will be 1% and the data will be converted as follows:

$$100 \text{ (\%)} / 1 \text{ (\%)} = 100 = 0064 \text{ Hex}$$

→ 2's complement: FF9C Hex

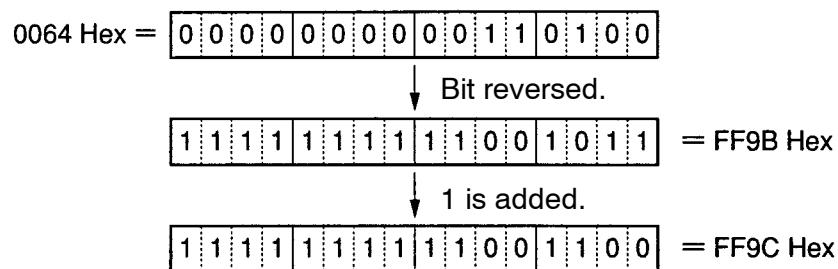

Note Whether the data is positive or negative is determined by the parameter set value.

The MSB of negative-value data is always set to 1. Data with its MSB set to 1 is not, however, always negative-value data.

For example, the setting range of the n083 parameter (register 0153 Hex: jump frequency 1) is within a range from 0.00 to 400.00 Hz. If the jump frequency is 400.0 Hz, the data is obtained from the following formula and its MSB will be 1. $400.0 \text{ (Hz)} / 0.001 \text{ (Hz)} = 4000 = 9C40 \text{ Hex}$

● **Setting All Unused Bits to 0**

- Bits 11 through 15 of the RUN command (register 0001 Hex) are unused. When writing the data, be sure to set all of these bits to 0. These bits when read are set to 0.

● **No Data Settings in Unused Registers**

- Registers described “not used” may be used for internal processing. Do not write any data to such registers.

7-6 Register Number Allocations in Detail

The following description provides information on register numbers allocated to the Inverter and the meanings of the registers. As for the register numbers of the parameters (n001 through n179), refer to *Section 10 List of Parameters* and the description of each of these parameters wherever explained in this manual.

7-6-1 I/O Function

■ Communications with a Single Slave with Addresses 01 to 32 (01 to 20 Hex) Read/Write

Register No. (Hex)	Function	Description
0000	Not used	---
0001	RUN command	Refer to the table below.
0002	Frequency reference	Set the frequency reference in the unit according to the set value in n152.
0003	V/f gain	Set on condition that 100% is 1000 within a range from 2.0 to 200.0% (20 to 2000). (see note 1)
0004 to 0008	Not used	---
0009	Inverter output	Refer to the table below.
000A to 000F	Not used	---

Note 1. The V/f gain is a rate to be multiplied by the output voltage obtained from V/f operation. If 1000 (03E8 Hex) is set, the multiplication rate will be 1.

Note 2. When the above registers are read, values that are set through communications will be read. For example, when the RUN command (register 0001) is read, the control input in the register that was previously set through communications will be returned. This is not a value monitored through the input signal terminal.

● **RUN Command (Register 0001 Hex)**

Bit No.	Function
0	RUN command (1: RUN)
1	Forward/Reverse (1: Reverse)
2	External fault (External fault EF0)
3	Fault reset (1: Fault reset)
4	Multi-function input 1 (1: ON)
5	Multi-function input 2 (1: ON)
6	Multi-function input 3 (1: ON)
7	Multi-function input 4 (1: ON)
8	Multi-function input 5 (1: ON)
9	Multi-function input 6 (1: ON)
10	Multi-function input 7 (1: ON)
11 to 15	Not used

Note There is an OR relationship between input from the control terminals and input through communications. Therefore, if multi-function inputs of this register are set to forward/stop and reverse/stop, it is possible to execute the RUN command through the multi-function inputs. These settings are not, however, recommended because these settings establish two command lines.

● **Inverter Output (Register 0009 Hex)**

Bit No.	Function
0	Multi-function contact output (1: ON)
1	Multi-function output 1 (1: ON)
2	Multi-function output 2 (1: ON)
3 to 15	Not used

Note The settings will be enabled if multi-function outputs 1 through 3 in n057 through n059 are set to 18 for communications output. Then the corresponding output terminal will be turned ON and OFF through communications.

■ **Broadcast Message with Slave Address: 00 (00 Hex)** **Write**

Register No. (Hex)	Function	Description
0000	Not used	---
0001	RUN command	Refer to the table below.
0002	Frequency reference	Set the frequency reference based on the maximum frequency as 30,000.
0003 to 000F	Not used	---

Note 1. Data can be written to registers 0001 and 0002 only.

Note 2. No data can be written to multi-function input.

Note 3. The unit of setting of the broadcast message is different from that in the DSR message to communicate with a single Slave.

● **RUN Command (Register 0001 Hex)**

Bit No.	Function
0	RUN command (1: RUN)
1	Forward/Reverse (1: Reverse)
2	External fault (1: External fault EF0)
3	Fault reset (1: Fault reset)
4 to 15	Not used

7-6-2 Monitor Functions

Register No. (Hex)	Function	Description
0020	Status signal	Refer to the following corresponding table.
0021	Fault status 1	Refer to the following corresponding table.
0022	Data link status	Refer to the following corresponding table.
0023	Frequency reference	According to the set value in n152.
0024	Output frequency	According to the set value in n152.
0025 to 0026	Not used	---
0027	Output current	Read based on 1 A as 10.
0028	Output voltage	Read based on 1 V as 1.
0029	Fault status (see note 2)	Refer to the following corresponding table.
002A	Warning (see note 2)	Refer to the following corresponding table.
002B	Input terminal status	Refer to the following corresponding table.
002C	Inverter status	Refer to the following corresponding table.
002D	Output terminal status	Refer to the following corresponding table.
002E		Refer to the following corresponding table.
002F to 0030	not used	---
0031	Main circuit DC voltage	Read based on 1 V as 1.
0032	Torque reference	Read based on $\pm 1\%$ as ± 1 and the rated motor torque is 100%.
0033 to 0034	Not used	---
0035		Read based on 1 [h] as 1
0036	Not used	---
0037	Output power	Read based on ± 1 kW as ± 100 .
0038	PID feedback	Read based on 1% as 10 and a value equivalent to the maximum frequency as 100%.

Register No. (Hex)	Function	Description
0039	PID input	Read based on $\pm 1\%$ as ± 10 and a value equivalent to the maximum frequency as 100%.
003A	PID output	Read based on $\pm 1\%$ as ± 10 and a value equivalent to the maximum frequency as 100%.
003B to 003C	Not used	---
003D	Communications error	Refer to the following corresponding table.
003E to 00FF	Not used	---

Note The fault status 2, warning status, Inverter status 2, and accumulated operating time functions are provided for 5.5kW and 7.5kW Inverters only.

● **Status Signal (Register 0020 Hex)**

Bit No.	Function
0	During RUN (1: During RUN)
1	Forward/reverse operation (1: Reverse operation)
2	Inverter ready (1: Ready)
3	Fault (1: Fault)
4	Data setting error (1: Error)
5	Multi-function output 1 (1: ON)
6	Multi-function output 2 (1: ON)
7	Multi-function output 3 (1: ON)
8 to 15	Not used

● **Fault Status 1 (Register 0021 Hex)**

Bit No.	Function	Bit No.	Function
0	OC	8	F□
1	OV	9	OL1
2	OL2	10	OL3
3	OH	11	Not used
4	Not used	12	UV1
5	Not used	13	UV2
6	FBL	14	CE
7	EF□, STP	15	OPR

Note When a fault results, the corresponding bit will be set to 1.

● **Data Link Status (Register 0022 Hex)**

Bit No.	Function
0	Data writing (1: Writing)
1 to 2	Not used
3	Upper and lower limit error (1: Error): Outside set range
4	Verify fault (1: Error): Same as OPE□.
5 to 15	Not used

● **Fault Status 2 (Register 0029 Hex)**

Bit No.	Function
0	SC
1	GF
2	PF
3	LF
4	RH
5	RR
6 to 15	Not used.

● **Warning Status (Register 002A Hex)**

Bit No.	Function
0	STP (Emergency stop)
1	SER
2	EF
3	BB
4	OL3
5	OH
6	OV
7	UV
8	FAN
9 to 11	Not used.
12	OH3
13	FBL
14	STP (Emergency stop)
15	Not used.

● **Input Terminal Status (Register 002B Hex)**

Bit No.	Function
0	Multi-function input terminal 1 (S1) (1: ON)
1	Multi-function input terminal 2 (S2) (1: ON)
2	Multi-function input terminal 3 (S3) (1: ON)
3	Multi-function input terminal 4 (S1) (4: ON)
4	Multi-function input terminal 5 (S5) (1: ON)
5	Multi-function input terminal 6 (S6) (1: ON)
6	Multi-function input terminal 7 (S7) (1: ON)
7 to 15	Not used

● **Inverter Status 1 (Register 002C Hex)**

Bit No.	Function
0	During RUN (1: During RUN)
1	Zero speed (1: Zero speed)
2	Frequency agree (1: Frequency agree)
3	Alarm (Nonfatal error) (1: Warning)
4	Frequency detection 1 (1: Output frequency □ n095)
5	Frequency detection 2 (1: Output frequency □ n095)
6	Inverter ready (1: Ready)
7	UV (1: UV)
8	Base block (1: Base block)
9	Frequency reference mode (1: Other than communications)
10	RUN command mode (1: Other than communications)
11	Overtorque detection (1: Overtorque detection)
12	Not used
13	Fault retry (1: Fault retry)
14	Fault (1: Fault)
15	Communications time-over: No normal communications for 2 s or more (1: Communications time-over detecting)

● **Output Terminal Status (Register 002D Hex)**

Bit No.	Function
0	Multi-function contact output terminal MA (1: ON)
1	Multi-function photocoupler output terminal 1 (P1) (1: ON)
2	Multi-function photocoupler output terminal 2 (P2) (1: ON)
3 to 15	Not used

● **Inverter Status 2 (Register 002E Hex)**

Bit No.	Function
0	Frequency reference loss
1 to 15	Not used.

● **Communications Error (Register 003D Hex)**

Bit No.	Function
0	CRC error (1: Error)
1	Data length error (1: Error)
2	Not used
3	Parity error (1: Error)
4	Overrun error (1: Error)
5	Framing error (1: Error)
6	Communications time-over (1: Error)
7 to 15	Not used

7-7 Communications Error Codes

The Inverter will detect a communications error if normal communications fail or a message data error occurs.

The Inverter returns a response that consists of the Slave address, function code with the MSB set to 1, error code, and CRC-16 check block when the communications error is detected.

When the Master receives an error code, refer to the following table for troubleshooting and remedying the error.

■ Errors and Remedies

Error code	Name	Probable cause	Remedy
01 Hex	Function code error	The function code is set to a code other than 03, 08, or 10 Hex.	Check and correct the function code.
02 Hex	Register number error	The specified register number has not been registered.	Check and correct the register number.
		An attempt was made to read the register of the Enter command.	
03 Hex	Data number error	The number of write or read registers is not within a range from 1 to 16 (0001 and 0010 Hex).	Check and correct the number of registers or the number of bytes.
		The number of registers of the DSR message multiplied by two does not coincide with the number of bytes of the attached data.	
21 Hex	Data setting error	The write data is not within the permissible range.	Check the display on the Digital Operator and correct the data.
		The data set is illegal and causes an OPE (OPE1 through OPE9) error.	

Error code	Name	Probable cause	Remedy
22 Hex	Write mode error	The Inverter in operation received a DSR message to write data to a parameter that prohibits any data to be written while the Inverter is running.	Write the data after stopping the Inverter.
		The Enter command was received while the Inverter is running.	
		The Inverter detecting UV received a DSR message to write data.	Write the data after restoring the UV (main circuit undervoltage) status.
		The Inverter detecting UV received the Enter command.	
		The Inverter detecting F04 for an initialization memory fault received a DSR message other than that for parameter initialization (with n001 set to 8 or 9).	Turn the Inverter OFF and ON after parameter initialization with n001 set to 8 or 9.
		The Inverter processing data written received a DSR message to write data.	Wait for an elapse period equivalent to 24 bits plus a minimum of 10 ms to issue the message after a response is received from the Inverter.
		A DSR message to a read-only register was received.	Check and correct the register number.

7-8 Self-diagnostic Test

The Inverter incorporates a self-diagnostic test function that checks whether RS-422/485 communications are functioning.

If the Inverter has a communications failure, take the steps provided below to check whether the communications function of the Inverter is normal.

■ Self-diagnostic Test Steps

1. Set the Parameter

- Set n056 for multi-function input 7 (S7) to 35 through the Digital Operator.

2. Turn OFF the Inverter and Wire the Terminal

- Turn OFF the Inverter and wire the following control terminals. At this time, make sure that all other circuit terminals are open.

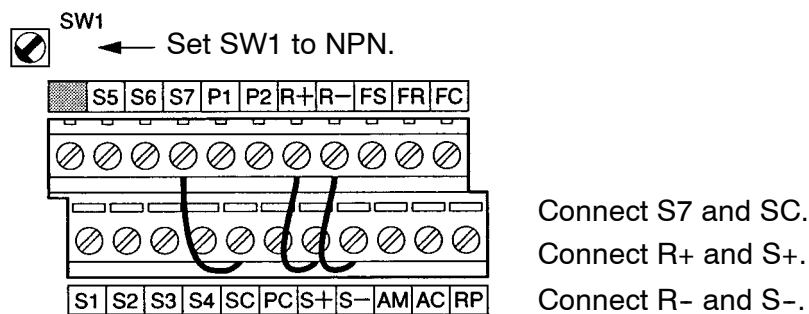

3. Turn ON the Inverter and Check the Display

- Turn ON the Inverter.
- Check the display on the Digital Operator.

Normal

The display is normal with no error code displayed.

Fault

The display shows “CE” (communications time-over) or “CAL” (communications standby). In either case, the communications circuit of the Inverter is broken. Replace the Inverter.

7-9 Communications with Programmable Controller

The Communications Board can be mounted to OMRON's SYSMAC CS1-series or C200HX/HG/HE CPU Unit. The Inverter can then be controlled by the Communications Board through its RS-422/485 port.

The communications protocol can be set by using the protocol macro function. Therefore, there is no need to write a ladder program for the communications protocol when the function is used.

The following description provides information on how to control the Inverter through communications with the SYSMAC CS1-series or C200HX/HG/HE Communications Board by using the protocol macro function.

The RS-422/485 communications of the 3G3MV Inverter conform to the MODBUS Communications Protocol and this protocol cannot be used together with CompoBus/D communications protocol or any other communications protocol. Only 3G3MV-series Units can be connected as Slaves. (The MODBUS Communications Protocol is a trademark of AEG Schneider Automation.)

7-9-1 Available Programmable Controller and Peripheral Device

■ OMRON's SYSMAC CS1-series or C200HX/HG/HE Programmable Controller

- The Communications Board can be mounted to the following SYSMAC CS1-series or C200HX/HG/HE CPU Unit.

Series	CPU model
SYSMAC CS1 Series	High-speed models: CS1H-CPU67-E, CS1H-CPU66-E, CS1H-CPU65-E, CS1H-CPU64-E, and CS1H-CPU63-E Low-speed models: CS1G-CPU45-E, CS1G-CPU44-E, CS1G-CPU43-E, and CS1G-CPU42-E
SYSMAC C200HX/HG/HE	C200HX-CPU34-E/44-E/54-E/64-E/34-ZE/44-ZE/54-ZE/64-ZE/65-ZE/85-ZE C200HG-CPU33-E/43-E/53-E/63-E/33-ZE/43-ZE/53-ZE/63-ZE C200HE-CPU32-E/42-E/32-ZE/42-ZE

■ **Communications Board**

- The following Communications Boards are available.

Note The RS-232C port can be used if an RS-422/485 conversion adapter is installed. For ease of wiring, however, it is recommended that the RS-422/485 port be used. The following information is for the RS-422/485 port.

Series	Communications Board model	Mounting method	Specifications
SYSMAC CS1 Series	CS1W-SCB41	As an inner board of the CPU Unit	<ul style="list-style-type: none"> • One RS-232C port • One RS-422/485 port • Protocol macro function
SYSMAC C200HX/HG/HE	C200HW-COM06-EV1 Note Make sure that the model number has the suffix "EV1," otherwise the CRC-16 check code cannot be used.	Mounted to an optional slot of the CPU Unit	<ul style="list-style-type: none"> • One RS-232C port • One RS-422/485 port • Protocol macro function

■ **Peripheral Devices**

- The following peripheral devices are required to use the protocol macro function.

Name	Model	Specification	
CX-Protocol	WS02-PSTC1-E	The following peripheral devices support the protocol macro function of the SYSMAC CS1 Series.	
		Personal computer environment	
		Personal computer	IBM PC/AT or compatible computer
		CPU	Minimum requirement: Pentium 90 MHz Recommended: Pentium 166 MHz or faster
		OS	Microsoft Windows 95 or Windows 98
		Memory	Minimum: 16 MB Recommended: 24 MB min.
		Hard disk	Minimum: Available space of 24 MB Recommended: Available space of 50 MB
		Monitor	SVGA or better
		Drive	FDD: 1 or more CD-ROM drive: 1 or more

Name	Model	Specification	
Protocol Support Tool	WS01-PSTF1-E	The following peripheral devices support the protocol macro function of the SYSMAC C200HX/HG/HE.	
		Personal computer environment	
		Personal computer	IBM PC/AT or compatible computer
		CPU	Minimum requirement: Pentium 90 MHz Recommended: Pentium 166 MHz or faster
		OS	Microsoft Windows 95 or Windows 98
		Memory	Minimum: 16 MB Recommended: 24 MB min.
		Hard disk	Minimum: Available space of 24 MB Recommended: Available space of 50 MB
		Monitor	SVGA or better
		Drive	FDD: 1 or more CD-ROM drive: 1 or more

■ **Manuals**

- Refer to the following manuals for the peripheral devices and support software in detail.

Product	Catalog No.
SYSMAC CS1-series Programmable Controllers	Operation Manual: W339 Programming Manual: W340
SYSMAC C200HX/HG/HE Programmable Controllers	Installation Manual: W302 Operation Manual: W303
CS1W-SCB41 Serial Communications Board	W336
C200HW-COM06-EV1 Communications Board	W304
WS02-PSTC1-E CX-Protocol	W344
WS01-PSTF1-E Protocol Support Tool	W319

7-9-2 Wiring the Communications Line

■ Connector Pin Arrangements of CS1W-SCB41 and C200HW-COM06-EV1

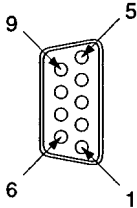

Pin No.	Code	Signal name	I/O
1	SDA	Send data (-)	Output
2	SDB	Send data (+)	Output
3	NC	---	---
4	NC	---	---
5	NC	---	---
6	RDA	Recv data (-)	Input
7	NC	---	---
8	RDB	Recv data (+)	Input
9	NC	---	---
Frame	FG	FG	---

■ Standard Connection Diagram

● RS-485 (2-wire)

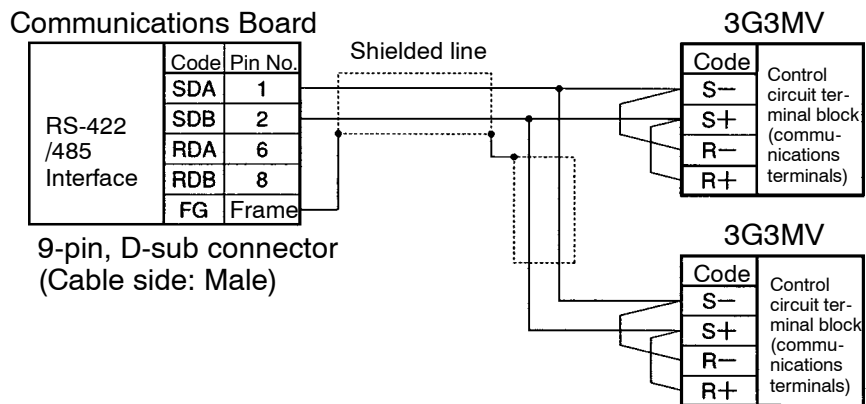

Note Be sure to set the terminal resistance of only the Inverter at each end to ON and that any other Inverter to OFF. Refer to page 2-18, *Selecting RS-422/485 Termination Resistance* for details.

● RS-422 (4-wire)

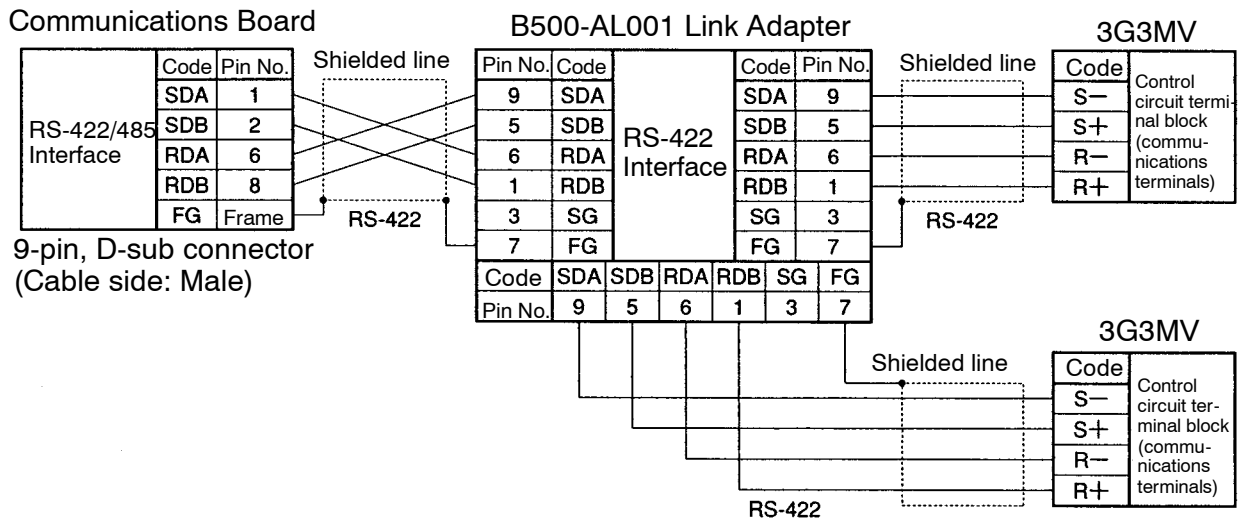

Note Turn the terminal resistance of all the Inverters to ON for RS-422 communications. Refer to page 2-18, *Selecting RS-422/485 Termination Resistance* for details.

7-9-3 Outline of Protocol Macro Function

■ Protocol Macro Function

- The protocol macro function makes it possible to customize a communications protocol in order to create a macro according to the specifications of the serial communications port of the general-purpose peripheral device.
- The protocol macro function is mainly used for the following jobs.
 - Creation of message communications frame.
 - Creation of Send & Recv procedures for message communications frame.

Note This manual uses the terms “message, DSR message, and response” to express the communications data exchanged.

- Message: A DSR message or response.
- DSR Message: A message sent by the Master for instructions to the Inverter.
- Response: A message that the Inverter returns in compliance with a DSR message from the Master.

● Creating a Message

- The message can be created according to the communications specifications of the general-purpose peripheral device (Inverter) as a counterpart.

- A DSR message can include variables to set data in the I/O memory (such as data memory) of the CPU Unit or write response data to the I/O memory.
- Each component of a message is in the memory of the Communications Board. Therefore, the CPU Unit can just execute the PMCR instruction to send or receive the data. Therefore, there is no need to write ladder programs for the communications protocol.

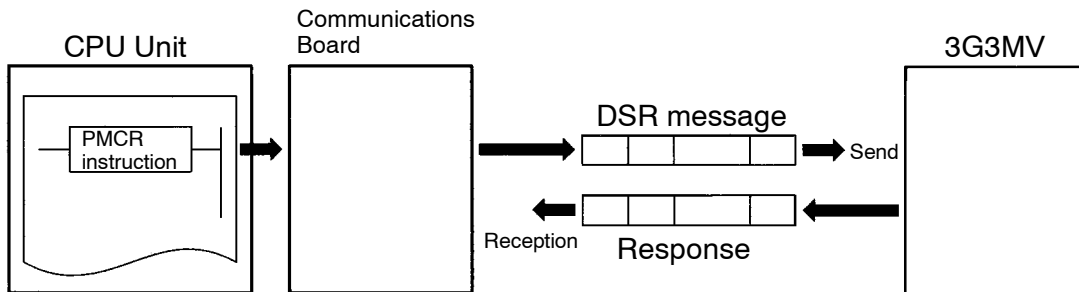

● **Step to Send and Receive Messages**

- Sending and receiving messages as a single step includes step-type commands, such as Send, Recv, Send & Recv, and Wait commands.
- The step can be finished or switched to another step according to the result of the step.

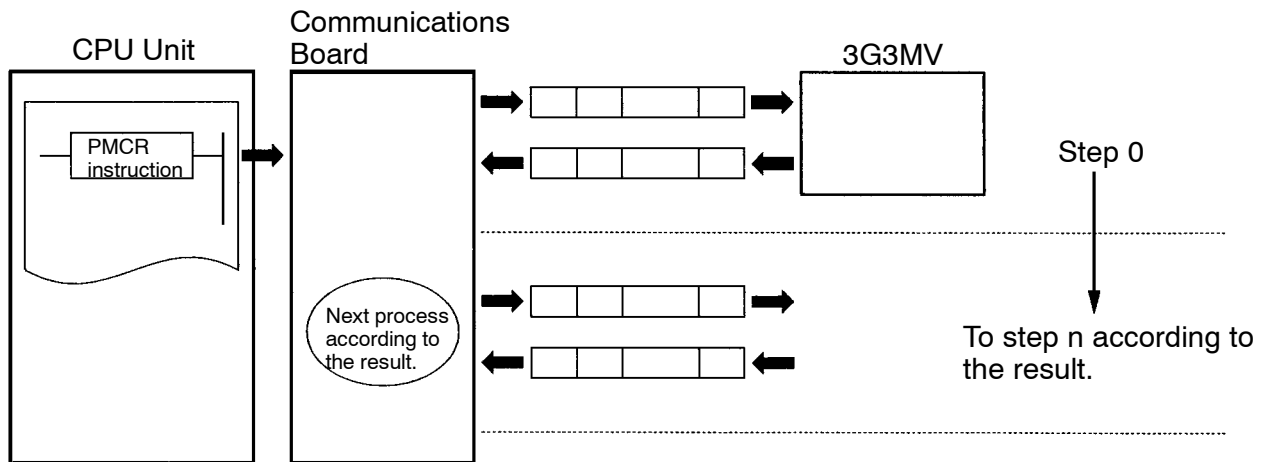

■ **Configuration of Protocol Macro Function**

- The protocol consists of one or more sequences.
A sequence is an independent set of actions to perform together with a general-purpose peripheral device, such as an Inverter. The RUN command and the frequency reference are given to the Inverter and the status of the Inverter is read in a single sequence, for example.
- A sequence consists of one or more steps.

● **Sequence**

- When repeating actions to give the RUN command and frequency reference to the Inverter and read the status of the Inverter, for example, the actions can be registered as one sequence, or more than one if necessary. In 7-9-4 *Creating a Project File*, an example is shown with all actions registered as a single sequence.
- A sequence may include the following parameters.

Parameter	Description
Transmission control parameter	Set the method of control, such as flow control. Note Select only model control for communications with the 3G3MV.
Link word	Set the area for sharing the data between the Programmable Controller and Communications Board. Note In 7-9-4 <i>Creating a Project File</i> , an example is shown without such an area set.
Monitor time	Set the periods to monitor the transmission and reception steps with timers Tr, Tfr, and Tfs. Note Set a period of approximately 0.5 s each for communications with the 3G3MV.
Response notify method	A method to write reception data to the I/O memory of the Programmable Controller. Note Select “notify by scan” for communications with the 3G3MV.

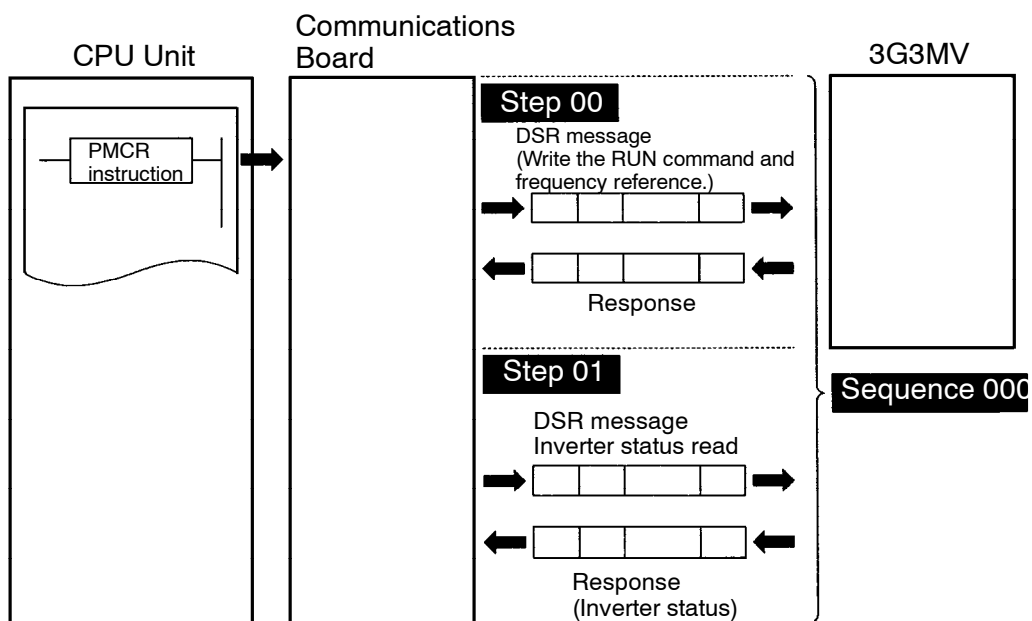

● **Step**

- In a single step, a DSR message is sent and a response for the DSR message is received. A step may not include a response if it is a broadcast message.

- In the case of repetitive actions to issue the RUN command and frequency reference to the Inverter and read the status of the Inverter, for example, the actions to give the RUN command and frequency reference is one step. The reason is that these register numbers are consecutive and can be sent with a single DSR message. The action to read the status of the Inverter is another step.
- A step includes a command and a maximum of two messages.
The above example uses the Send & Recv command. The DSR message and response are both messages.
- A step may include the following parameters.

Parameter		Description
Command		The Send, Send & Recv, Wait, Flush, Open (ER-ON), or Close (ER-OFF) command is set. Note In 7-9-4 <i>Creating a Project File</i> , an example is shown with the Send & Recv command used. The Send command is used for a broadcast message.
Message	Send message	A DSR message is set for the Send command used.
	Recv message	A response is set for the Recv command.
	Send & Recv message	A DSR message and response are set for the Send & Recv command.
	Recv matrix	If there are two or more responses for the Send or Send & Recv command, the next process is selected per response.
Repeat counter		The number (N) of times to repeat the step is set within a range from 0 to 255. It is possible to change messages by making use of the number (N). Note In 7-9-4 <i>Creating a Project File</i> , an example is shown with this function used for enabling three Slaves to repeat the same process.
No. of retries		The number of times to retry the command can be set within a range from 0 to 9 only when the Send & Recv command is used. Note It is recommended that the number be set to 3 or larger.
Send Wait Time		The waiting time until data is sent with the Send or Send & Recv command executed.
Response Write (with operand specified)		Determines whether or not to write the reception data in the response. Note In 7-9-4 <i>Creating a Project File</i> , an example is shown with this function used for writing the Inverter status to the memory.

Parameter	Description
Next process	Determines which step is to be processed next or finishes the operation after the step is finished normally.
Error processing	Determines which step is to be processed next or finishes the operation, if the step has an error.

■ Data Created by Protocol Support Tool

- A project file is used by the Protocol Support Tool to create and control data. A project file consists of the following data.

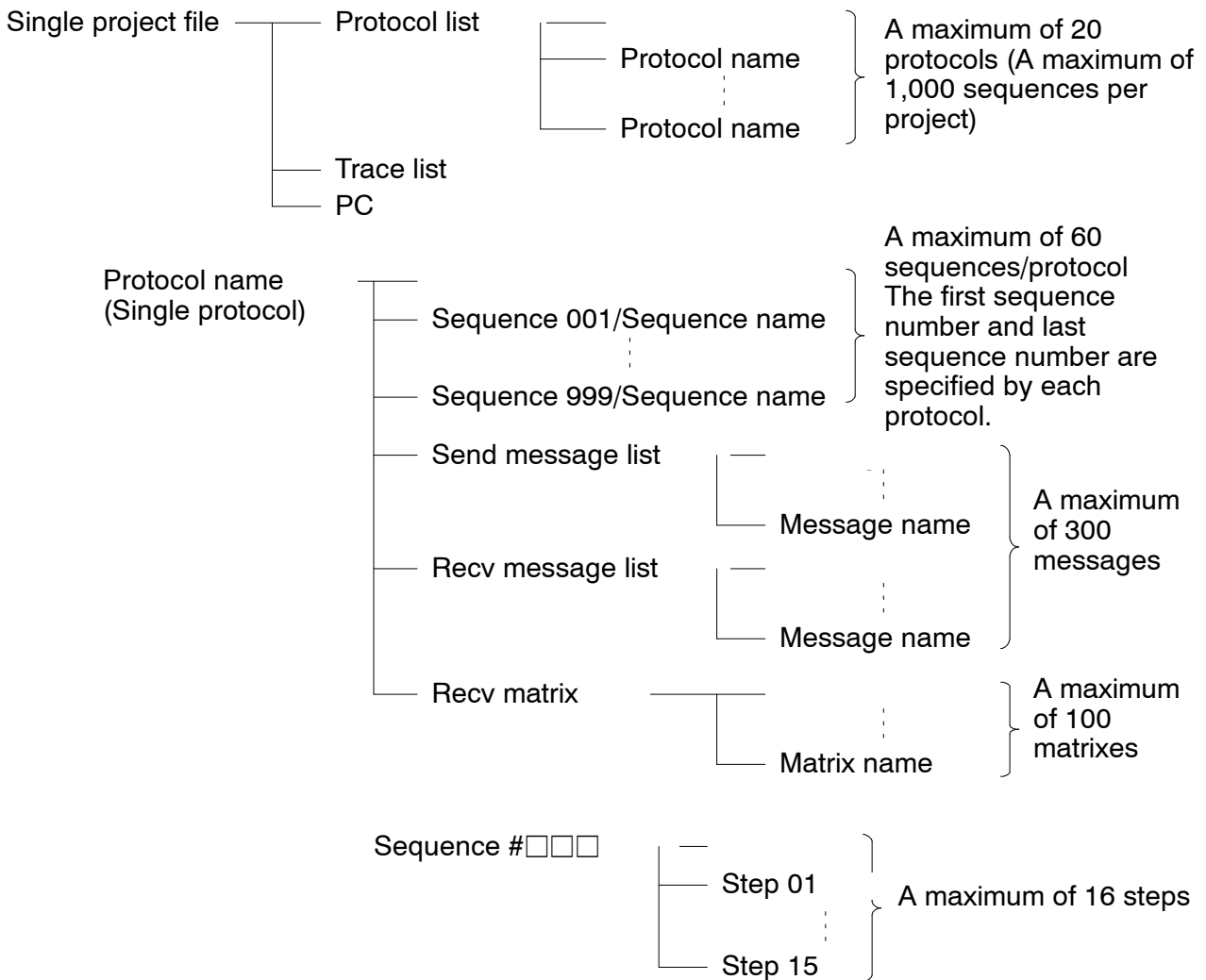

Note The standard system protocol incorporated by the Communications Board cannot be edited or transferred. To make use of the standard system protocol, copy it to the project file and edit it.

In 7-9-4 *Creating a Project File*, an example to create a new project file is shown without making use of the standard system protocol.

7-9-4 Creating a Project File

- The following description provides information about how to create a project file to issue the RUN command and frequency reference and read the Inverter status.

■ Design

- Select from I/O items, monitor items, and parameters the data to be exchanged according to the application. Then consider what sequence is required by using the protocol macro function.

Example: Writes control input items (such as the RUN command and multi-function input) of the Inverter and frequency reference, monitors the control output (such as error output and RUN output) of the Inverter, and monitors the Inverter status.

Three Inverters with Slave addresses from 01 to 03 are installed for communications.

● Checking the Register Numbers

- In the above example, the following three registers are required.

Control Input:	Register 0001 Hex for RUN command
Frequency Reference:	Register 0002 Hex
Control Output:	Register 002C Hex for Inverter status

● Memory Allocations

- The PMCR instruction sends each Slave the data in consecutive words specified by the operand and beginning with the first word (S), and writes in the memory area beginning with the first word (D) the data received.

- The following memory allocations are made in the above example.

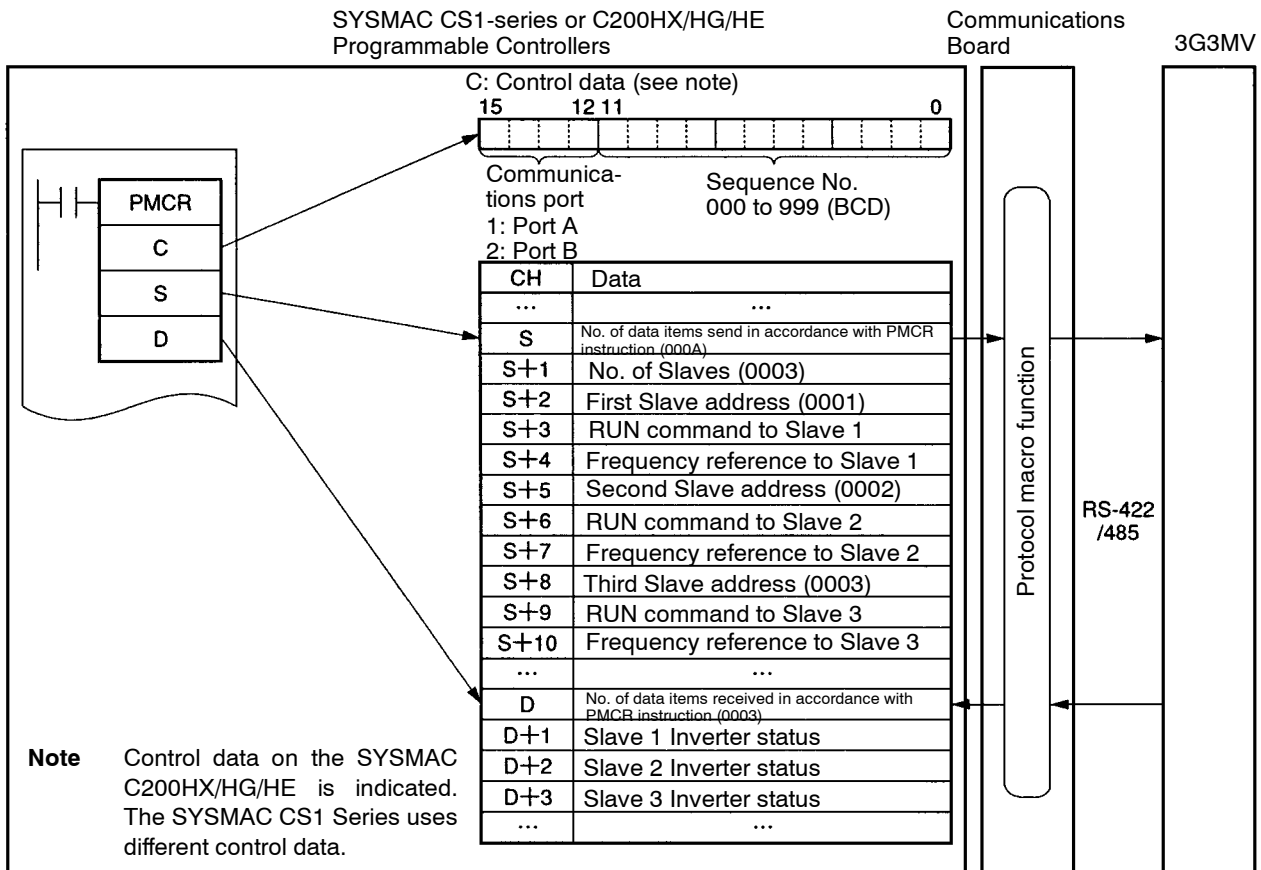

■ Creating a New Project and Protocol

1. Select **New** from the **File** in the Menu Bar or click on the **New** icon with the left button of the mouse to create a new project.
2. If CX-Protocol is used, set the PC name, PC model, and network type according to the actual conditions.

Note 1. The network type refers to the type of the network connected to the Support Software and it does not refer to the communications configuration between the Programmable Controller and the 3G3MV Inverter.

Note 2. The above settings will not be displayed if the Protocol Support Tool is used.

3. Double-click on **New Project** with the left button of the mouse to display **List of Protocols**.
4. Click on **List of Protocols** with the left button of the mouse and click on a blank space with the right button of the mouse.
5. Select **New Protocol**.

■ Creating a Sequence

1. Click on **New Protocol** with the left button of the mouse. Then click on a blank space with the right button of the mouse.
2. Select **New Send & Recv Sequence**.

The following table will appear. Set the parameters related to the sequence in the table.

*	#	Send & Recv sequence	Link word	Transmission control parameter	Response	Timer Tr	Timer Tfr	Timer Tfs
	000	Inverter I/O Send & Recv	---	Set (Setting required)	Scan	0.5	0.5	0.5

#

Sequence number. The sequence number is automatically set.

Send & Recv Sequence

The label (name) of the sequence. Input an appropriate, easy-to-distinguish name.

Link Word

Set the area for sharing the data between the Programmable Controller and Communications Board.

Note In this example, the link word is specified by the operand of the PMCR instruction. Therefore, no link word is set here.

Transmission Control Parameter

Set the control method, such as flow control.

Note Select only model control for communications with the 3G3MV.

Response

A method to write reception data to the I/O memory of the Programmable Controller.

Note Select “notify by scan” for communications with the 3G3MV.

Timer Tr
Timer Tfr
Timer Tfs

Set the periods to monitor the transmission and reception steps with timers Tr, Tfr, and Tfs. The following timing chart shows the meaning of each monitor.

Be sure to set the periods according to the application.

The step will be retried if the step is not completed within the monitor periods. An error will occur if the step is not completed within the monitor time again.

Note Set a period of approximately 0.5 s each for communications with the 3G3MV.

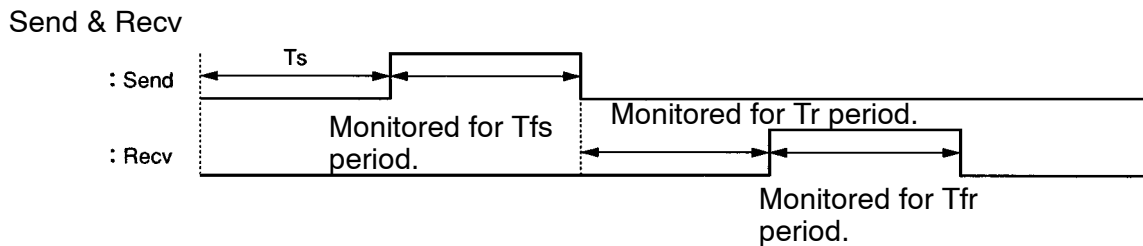

T_s : Send wait time set per step. Nothing is sent during this period.

T_{fs} : Monitors the completion of the data sent. If the data transmission is not finished within this period, the data will be re-transmitted.

T_r : Monitors the response to be received. If the response is not returned within this period, the response will be re-transmitted.

T_{fr} : Monitors the reception completion of the response. If the response transmission is not finished within this period, the response will be re-transmitted.

Note If the T_r period is too long, the time required to detect a communications error will be longer, during which the Inverter cannot be controlled. Therefore, be sure to set an appropriate period.

■ **Creating a Step**

1. Double-click on **Protocol** with the left button of the mouse.
2. Click on **Sequence** with the left button of the mouse and click on a blank space with the right button of the mouse.
3. Select **New Step**.

The following table will appear. Set the parameters related to the step in the table.

*	Step	Repeat counter	Command	No. of retries	Send wait time	Send message	Recv message	Response write	Next process	Error process
<input type="checkbox"/>	00	Reset/R (1)	Send & Recv	3	---	Input send	Input response	Yes	Next	Abort
<input type="checkbox"/>	01	Reset/R (1)	Send & Recv	3	---	Status	Read response	Yes	End	Abort
<input type="checkbox"/>										

Step

Step number. The step number is automatically set.

Repeat Counter

The number (N) of times to repeat the step is set within a range from 0 to 255.

It is possible to change messages by making use of the number (N).

Note In this example, the same message is sent to three Slaves with addresses different to each other. Therefore, the number is set to 3 in word S + 1. The number of Slaves is specified by the operand. Therefore, select **Word**, use the Edit command to set **Data Address** to **Operand**, and set $0N + 1$ in order to select word S + 1.

In the above table, "Reset" means that the repeat counter must be reset first in the step.

Command

Set the commands, such as Send, Recv, and Send & Recv.

Note Only the Send & Recv command is used for communications with the 3G3MV except for sending broadcast messages, in which case the Send & Recv command is used.

No. of Retries

Set the number of times to retry the command within a range from 0 to 9.

Note It is recommended that the number be set to 3 or larger. If a transmission error occurs due to noise, the transmission of the command will be retried. If the number is set to 3, an error will be detected if the transmission fails three times.

Send Wait Time

The waiting time until the data is sent.

Note For communications with the 3G3MV, if data is repeatedly transmitted to the same Slave, set the waiting time to 10 ms or more.

In this example, the DSR message is sent to Slaves 1, 2, and 3 one by one. Therefore, no send wait time is set.

Send Message and Recv Message

Set the labels of the DSR message and response to be used.

Note Make these settings after deciding the labels in **Send Message Detail Settings** and **Recv Message Detail Settings**.

Response Write

Determine whether or not to write the reception data in the response.

Note Always set this parameter to Yes for communications with 3G3MV.

Next Process

Determine which step is to be processed next or finish the operation after the step finishes normally.

Note In this example, step 00 is set to Next and step 01 is set to END because the sequence completes by executing steps 00 and 01.

Error Processing

If the step has an error, determine which step is to be processed next or finish the operation.

Note In this example, the parameter will be set to Abort to interrupt the sequence if an error occurs.

*	Message	Header (h)	Terminator	Check code (c)	Length (l)	Address (a)	Data
→ <input type="checkbox"/>	Input send			*CRC-16 (65535) (2Byte BIN)	(0) (1Byte BIN)	(R (3N+2), 1)	<a> + [10] + [00] + [01] + [00] + [02] + <l> (R (3N + 3), 4) + <c>
→ <input type="checkbox"/>	Status			*CRC-16 (65535) (2Byte BIN)		(R (3N+2), 1)	<a> + [03] + [00] + [2C] + [00] + [01] + <c>
→ <input type="checkbox"/>							

Message

The label (name) of the sequence. Input an appropriate, easy-to-distinguish name.

Note Set the label in the send message box in the table shown under *Creating a Step*.

**Header (h)
Terminator (t)**

Set the header and terminator.

Note No header or terminator is used for communications with the 3G3MV. Therefore, set both to **No**.

Check Code (c)

Set the check code.

Note The CRC-16 check code is used for communications with the 3G3MV. Select the CRC-16 check code and set the initial value to 65535. Select **Reverse** for the conversion method. Then select **BIN**.

Length (l)

Set the length of the data.

Note All communications with the 3G3MV are performed in byte units. Select **1 Byte** and **BIN**. Select **No** for reading data because there is no data to be read.

Address (a)

Set the addresses of the Slaves.

Note In this example, the Slave addresses are set in S + 2, S + 5, and S + 8. Therefore, retrieve the data from those locations.

The address is set in the LSB of each word. To read the byte, select **Variable (Reverse)**, otherwise the data is read from the LSB. Then click on **Execute Address** with the left button of the mouse.

Select **Read R ()** and set **Data/Address** to the operand (3N + 2) using the number (N) of times to repeat the step.

Set **Data Size** to 1 byte as a default. If the default value has been changed, set it to 0N + 1.

Data

Set the DSR message in details.

• **DSR Message Requesting that the RUN Command and Frequency Reference be Written**

The DSR message to write data to two registers from register 0001 Hex (the RUN command) consists of the following items.

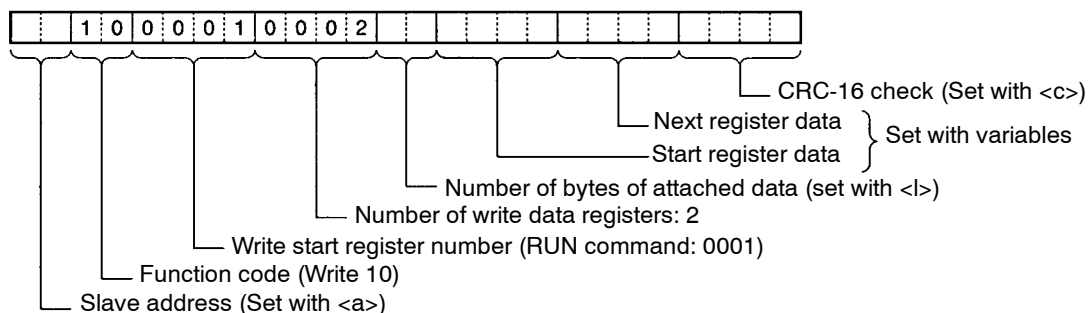

Set data: <a> + [10] + [00] + [01] + [00] + [02] + <l> + (R (3N + 3), 4) + <c>
<a>

The Slave address is set in the address box. Insert the address with the **Insert** icon.

[10] + [00] + [01] + [00] + [02]

Set the constants contained in the DSR message.

Use **Set Constant** and set the constants in Hex.

<l>

The length is set in the length box. Insert the length by using the **Insert** icon. The length is the number of bytes of the succeeding data (R(3N + 3), 4). The length is automatically set by the CX-Protocol.

(R(3N+3), 4)

The Inverter's actual data to be sent. This example selects **Variable** and **Read R()** and sets the operand. Set **Data** to 3N + 3 because the RUN command data uses four bytes each from S + 3, S + 6, and S + 9.

Set **Data Size** to 0N + 4 so that it will be set to four bytes.

<c>

The check code is set in the check code box. Insert the check code by using the **Insert** icon. All the data including the address data before the check code is operated. Mark all the items if the Protocol Support Tool is used. The check code is automatically set by the CX-Protocol.

• **DSR Message to Read the Inverter Status**

The DSR message to read the Inverter status from register 002C Hex consists of the following items.

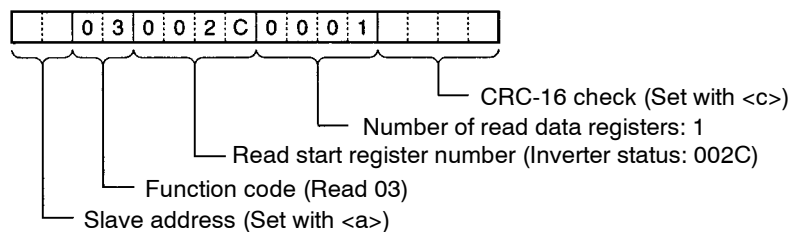

Set data: <a> + [03] + [00] + [2C] + [00] + [01] + <c>

Set the address data, constant data, and check code data.

■ **Recv Message Detail Settings**

1. With the left button of the mouse, click on **List of Recv Messages**. Then click on a blank space with the right button of the mouse.
2. Select **New** and **Recv Message**.
The following table will appear. Set the send message in the table.

*	Message	Header (h)	Terminator	Check code (c)	Length (l)	Address (a)	Data
→ <input type="checkbox"/>	Input response			*CRC-16 (65535) (2Byte BIN)		(R (3N+2), 1)	<a> + [10] + [00] + [01] + [00] + [02] + <c>
→ <input type="checkbox"/>	Read response			*CRC-16 (65535) (2Byte BIN)	(0) (1Byte BIN)	(R (3N+2), 1)	<a> + [03] + <l> + (W (1N + 1), 2) + <c>
→ <input type="checkbox"/>							

Message

The label (name) of the response. Input an appropriate, easy-to-distinguish name.

Note Set the label in the Recv message box in the table shown under *Creating a Step*.

**Header (h)
Terminator (t)**

Set the header and terminator.

Note No header or terminator is used for communications with the 3G3MV. Therefore, set both to **No**.

Check Code (c)

Set the check code.

Note The CRC-16 check code is used for communications with the 3G3MV. Select the CRC-16 check code and set the initial value to 65535. Select **Reverse** for the conversion method. Then select **BIN**.

Length (l)

Set the length of the data.

Note All communications with the 3G3MV are performed in byte units. Select **1 Byte** and **BIN**. Select **No** for reading data because there is no data to be read.

Address (a)

Set the addresses of the Slaves.

Note In this example, the Slave addresses are set in S + 2, S + 5, and S + 8. Therefore, retrieve the data from those locations.

The address is set in the LSB of each word. To read the byte, select **Variable (Reverse)**, otherwise the data will be read from the LSB. Then click on **Execute Address** with the left button of the mouse.

Select **Read R ()** and set **Data/Address** to the operand (3N + 2) using the number

(N) of times to repeat the step.

Set **Data Size** to 1 byte as a default. If the default value has been changed, set it to $0N + 1$.

Data

Set the expected response in details.

• **Response to the RUN Command and Frequency Reference**

The response to the DSR message written consists of the following items.

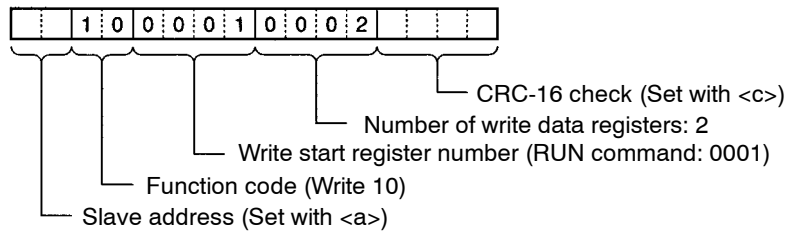

Set data: <a> + [10] + [00] + [01] + [00] + [02] + <c>

<a>

The Slave address is set in the address box. Insert the address with the **Insert** icon.

[10] + [00] + [01] + [00] + [02]

Set the constants contained in the response.

Use **Set Constant** and set the constants in Hex.

<c>

The check code is set in the check code box. Insert the check code by using the **Insert** icon. All the data including the address data before the check code is used. Mark all the items if the Protocol Support Tool is used. The check code is automatically set by the CX-Protocol.

• **Response to the Inverter Status Read**

The response to the DSR message to request the Inverter status in register 002C Hex consists of the following items.

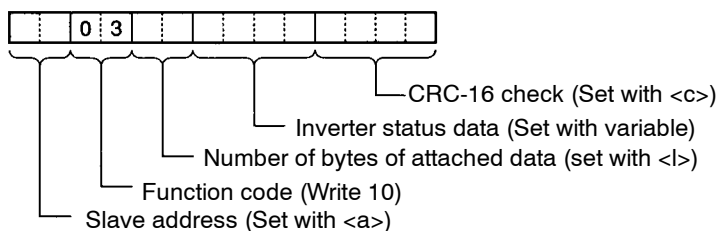

Set data: <a> + [03] + <l> + (W (1N + 1), 2) + <c>

<a.>, [03], <c>

The address data, constant data, and check code data are the same as the above.

<l>

The length is set in the length box. Insert the length by using the **Insert** icon. The length

is the number of bytes of the succeeding data ($W(1N + 1), 2$). The length is automatically set by the CX-Protocol.

$(W(1N + 1), 2)$

The Inverter's actual data is to be sent. This example selects **Variable** and **Read R()** and sets the operand. Set **Data** to $1N + 1$ because the RUN command data uses four bytes each from $D + 3$, $D + 6$, and $D + 9$.

Set **Data Size** to $0N + 2$ so that it will be set to two bytes.

7-9-5 Ladder Program

- Transfer the created protocol to the Communications Board.
- The following example describes how to control the Inverter with this protocol.
- Before using this program in your system, be sure to check the word and data memory allocations and change them if necessary so that there will be no word or data memory duplication.
- This program will stop all communications if a communications error or fault occurs. Be sure to set n151 for communications time-over detection selection to 0 through 2 so that the system will stop with time-over detection.

■ Memory Allocations

● Starting Communications and Status Signals

Word	Functions common to all Slaves
00000	Inverter control communications (continued when set to ON)
00001	Communications error output (on hold when a communications error or fault occurs)
00002	Communications fault reset

● Inverter Control Input (Register 0001 RUN Command)

Word	Slave 1 function	Word	Slave 2 function	Word	Slave 3 function
00100	RUN command	00200	RUN command	00300	RUN command
00101	Forward/Reverse	00201	Forward/Reverse	00301	Forward/Reverse
00102	External fault	00202	External fault	00302	External fault
00103	Fault reset	00203	Fault reset	00303	Fault reset
00104	Multi-function input 1	00204	Multi-function input 1	00304	Multi-function input 1
00105	Multi-function input 2	00205	Multi-function input 2	00305	Multi-function input 2
00106	Multi-function input 3	00206	Multi-function input 3	00306	Multi-function input 3
00107	Multi-function input 4	00207	Multi-function input 4	00307	Multi-function input 4
00108	Multi-function input 5	00208	Multi-function input 5	00308	Multi-function input 5
00109	Multi-function input 6	00209	Multi-function input 6	00309	Multi-function input 6
00110	Multi-function input 7	00210	Multi-function input 7	00310	Multi-function input 7
00111	Always set to 0.	00211	Always set to 0.	00311	Always set to 0.
00112	Always set to 0.	00212	Always set to 0.	00312	Always set to 0.
00113	Always set to 0.	00213	Always set to 0.	00313	Always set to 0.
00114	Always set to 0.	00214	Always set to 0.	00314	Always set to 0.
00115	Always set to 0.	00215	Always set to 0.	00315	Always set to 0.

● Frequency Reference of Inverter (Register 0002 Frequency Reference)

DM	Function
D0001	Slave 1 frequency reference
D0002	Slave 2 frequency reference
D0003	Slave 3 frequency reference

● Inverter Control Output (Register 002C Inverter Status)

Word	Slave 1 function	Word	Slave 2 function	Word	Slave 3 function
01100	RUN	01200	RUN	01300	RUN
01101	Stop	01201	Stop	01301	Stop
01102	Frequency coincide	01202	Frequency coincide	01302	Frequency coincide
01103	Alarm (Nonfatal error)	01203	Alarm (Nonfatal error)	01303	Alarm (Nonfatal error)
01104	Frequency detection 1	01204	Frequency detection 1	01304	Frequency detection 1
01105	Frequency detection 2	01205	Frequency detection 2	01305	Frequency detection 2
01106	Inverter ready	01206	Inverter ready	01306	Inverter ready
01107	UV	01207	UV	01307	UV
01108	Base block	01208	Base block	01308	Base block
01109	Frequency reference mode	01209	Frequency reference mode	01309	Frequency reference mode
01110	RUN command mode	01210	RUN command mode	01310	RUN command mode
01111	Overtorque detection	01211	Overtorque detection	01311	Overtorque detection
01112	0 (Not used)	01212	0 (Not used)	01312	0 (Not used)
01113	Fault retry	01213	Fault retry	01313	Fault retry
01114	Fault	01214	Fault	01314	Fault
01115	Communications time-over	01215	Communications time-over	01315	Communications time-over

● Area Used by Operand of PMCR Instruction

• Control Data: C

DM	Area
D0100	0 0 0 1 0 0 0 0 0 0 0 0 0 0 0 0

Communications port A selected Sequence 000 set

Note Control data on the SYSMAC C200HX/HG/HE is indicated. The SYSMAC CS1 Series uses different control data.

• Send Data: S

DM	Area
D1000	000A (No. of send data items: 10) (see note 1)
D1001	0003 (No. of Slaves)
D1002	0001 (Slave 1 address)
D1003	RUN command to Slave 1
D1004	Frequency reference to Slave 1
D1005	0002 (Slave 2 address)
D1006	RUN command to Slave 2
D1007	Frequency reference to Slave 2
D1008	0003 (Slave 3 address)
D1009	RUN command to Slave 3
D1010	Frequency reference to Slave 3

• Recv data: D

DM	Area
D2000	0003 (No. of Recv data items: 3) (see note 2)
D2001	Slave 1 Inverter status
D2002	Slave 2 Inverter status
D2003	Slave 3 Inverter status

Note 1. Set the number of send data items in Hex to the number of words of D10001 through D1010 (10).

Note 2. The number of words of D2001 through D2003 (3) is written in Hex the number of Recv data items.

■ Ladder Program

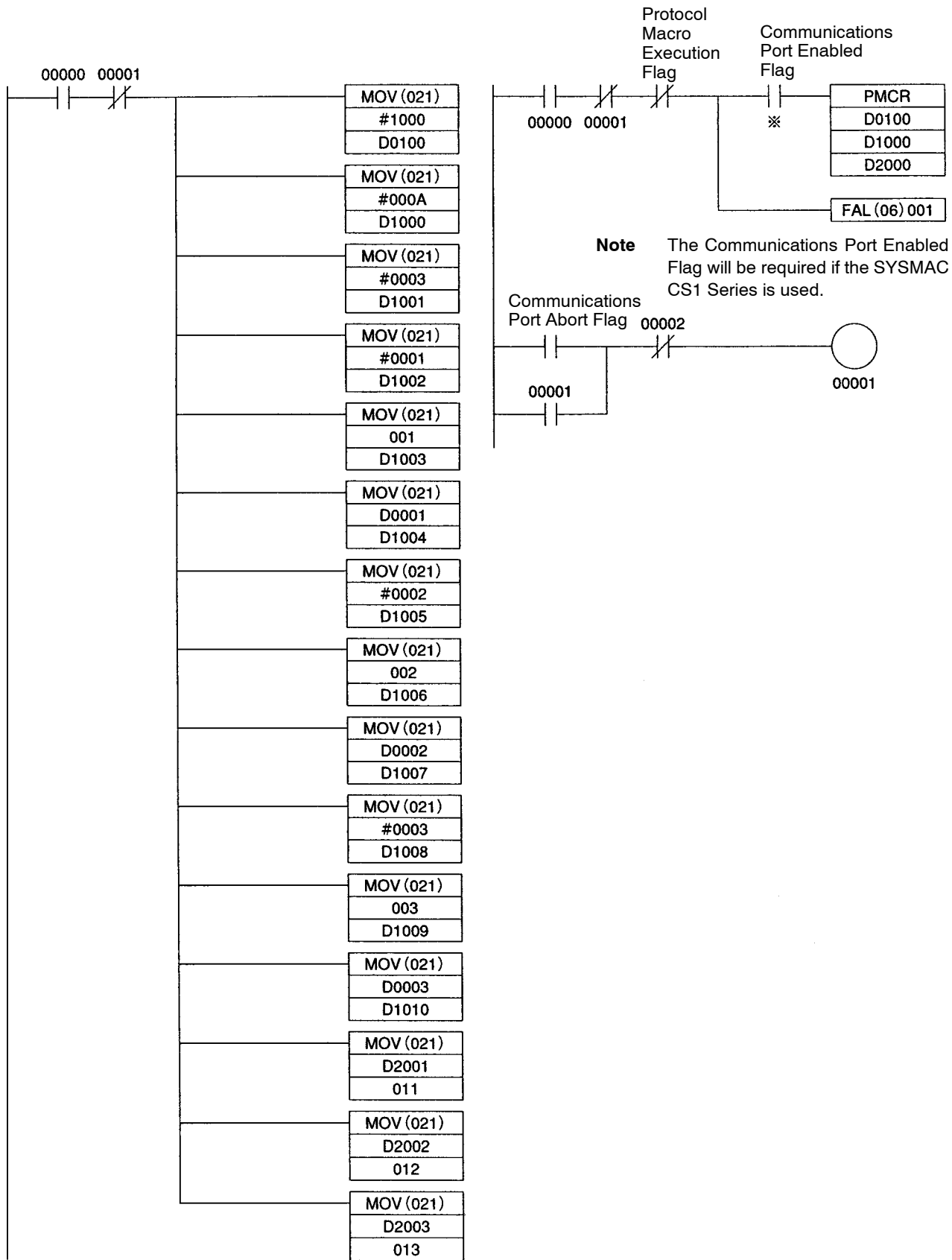

7-9-6 Communications Response Time

The communications response times for communications with an Inverter via the RS-422/485 port of an OMRON-made Communications Board are detailed below. Use this information as a reference when deciding the number of Slaves to be connected to one network, and when considering the timing of input and output signals.

■ Communications Time for One Message

- A wide variety of programs for RS-422/485 communications can be created using the protocol macro function. The communications times will vary according to the contents of the program.
- In general, the communications time for one message can be calculated using the following formula.

Communications time = [No. of bytes in DSR message × 10 (see note 1) × (1/ baud rate) × 1,000 (ms)] + [No. of bytes in response × 10 × (1/ baud rate) × 1,000 (ms)] + [24 × (1/ baud rate) × 1,000 (ms)] + send wait time setting n156 (ms) + protocol macro waiting time (see note 2) (ms)

Note 1. The reason that the number of bytes in the DSR message and response is multiplied by 10 is because both the start bit and the stop bit require one bit each. (1 byte = 8 bits) + (start bit: 1 bit) + (stop bit: 1 bit) = 10 bits

Note 2. With RS-422/485 communications, set at least 20 ms as the protocol macro waiting time.

● Calculation Example

The communications time required for one Slave in the protocol macro created in 7-9-7 *Creating a Project File*, can be calculated according to the following formula. (Baud rate = 19,200 bps.)

Communications time = [(DSR message to write data (13 bytes) + DSR message to read (8 bytes)) × 10 × (1/19,200) × 1,000 (ms)] + [(write response (8 bytes) + read response (7 bytes)) × 10 × (1/19,200) × 1,000 (ms)] + [24 × (1/19,200) × 1,000 (ms) × 2] + [10 (ms) × 2] + [20 (ms) × 2] = 81.2 (ms)

Note If there are N Slaves, the total communications time will be N × 81.2 ms. Consequently, the more Slaves that are used, the longer the communications time will be. If the number of Slaves is too high, it is possible that the detection time of 2 s for communications time-over will be exceeded. In this case, either disable the time-over detection function and use a different sequence to detect communications errors, or increase the number of Masters thereby decreasing the number of Slaves per Master.

■ I/O Response Time

- The communications processing times for the Inverter are as follows.
 - Inverter communications input scan: 8 ms
 - Inverter communications output scan: 8 ms
 - Internal processing time for the Inverter: Approx. 20 ms
- The I/O response times for the Inverter are illustrated in the following diagram.

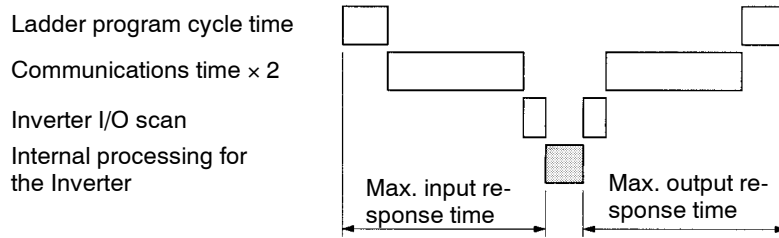

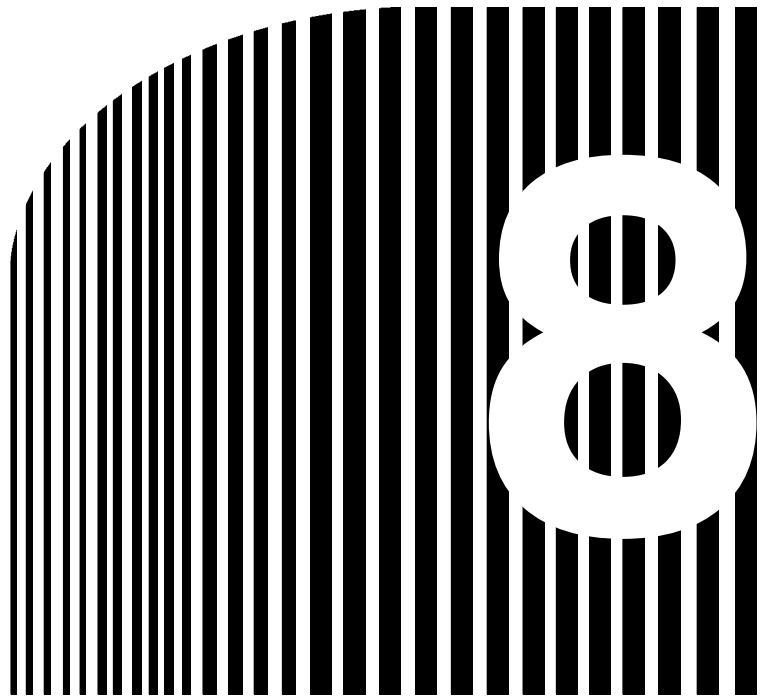

Chapter 8

• **Maintenance Operations** •

8-1 Protective and Diagnostic Functions

8-2 Troubleshooting

8-3 Maintenance and Inspection

8-1 Protective and Diagnostic Functions

8-1-1 Fault Detection (Fatal Error)

The Inverter will detect the following faults if the Inverter or motor burns or the internal circuitry of the Inverter malfunctions. When the Inverter detects a fault, the fault code will be displayed on the Digital Operator, the fault contact output will operate, and the Inverter output will be shut off causing the motor to coast to a stop. The stopping method can be selected for some faults, and the selected stopping method will be used with these faults. If a fault has occurred, refer to the following table to identify and correct the cause of the fault. Use one of the following methods to reset the fault after restarting the Inverter.

- Turn ON the fault reset signal. A multi-function input (n050 to n056) must be set to 5 (Fault Reset).
 - Press the STOP/RESET Key on the Digital Operator.
 - Turn the main circuit power supply OFF and then ON again.

■ Fault Displays and Processing

Fault display	Fault name and meaning	Probable cause and remedy
OC	<p>Overcurrent (OC) The Inverter output current is as high as or higher than 250% of the rated output current.</p>	<ul style="list-style-type: none"> • A short-circuit or ground fault has occurred and at the Inverter output. <ul style="list-style-type: none"> → Check and correct the motor power cable. • The V/f setting is incorrect. <ul style="list-style-type: none"> → Reduce the V/f set voltage. • The motor capacity is too large for the Inverter. <ul style="list-style-type: none"> → Reduce the motor capacity to the maximum permissible motor capacity. • The magnetic contactor on the output side of the Inverter has been opened and closed. <ul style="list-style-type: none"> → Rearrange the sequence so that the magnetic contactor will not open or close while the Inverter has current output. • The output circuit of the Inverter is damaged. <ul style="list-style-type: none"> → Replace the Inverter.

Fault display	Fault name and meaning	Probable cause and remedy
OU	<p>Overvoltage (OV) The main circuit DC voltage has reached the overvoltage detection level (410 VDC for 200-V Inverters, 820 VDC for 400-V Inverters)</p>	<ul style="list-style-type: none"> • There is excessive regenerative energy with no braking resistor or Braking Resistor Unit connected. <ul style="list-style-type: none"> → Connect the Braking Resistor Unit or a braking resistor. → Increase the deceleration time. • The regenerative energy has not been processed though a braking resistor or Braking Resistor Unit. <ul style="list-style-type: none"> → Set n092 for stall prevention during deceleration to 1 (disable) • The braking resistor or Braking Resistor Unit is not wired properly. <ul style="list-style-type: none"> → Check and correct the wiring. • The power supply voltage is too high. <ul style="list-style-type: none"> → Decrease the voltage so it will be within specifications. • There is excessive regenerative energy due to overshooting at the time of acceleration. <ul style="list-style-type: none"> → Suppress the overshooting as much as possible. • The braking transistor is damaged. <ul style="list-style-type: none"> → Change the Inverter.
uU1	<p>Main circuit undervoltage (UV1) The main circuit DC voltage has reached the undervoltage detection level (200 VDC for the 3G3MV-A2□, 160 VDC for the 3G3MV-AB□, and 400 VDC for the 3G3MV-A4□).</p>	<ul style="list-style-type: none"> • Power supply to the Inverter has phase loss, power input terminal screws are loose, or the power cable is disconnected. <ul style="list-style-type: none"> → Check the above and take necessary countermeasures. • Incorrect power supply voltage <ul style="list-style-type: none"> → Make sure that the power supply voltage is within specifications. • Momentary power interruption has occurred. <ul style="list-style-type: none"> → Use the momentary power interruption compensation (Set n081 so that the Inverter restarts after power is restored) → Improve the power supply. • The internal circuitry of the Inverter is damaged. <ul style="list-style-type: none"> → Change the Inverter.

Fault display	Fault name and meaning	Probable cause and remedy
uU2	<p>Control power supply undervoltage (UV2) The control power supply voltage has reached the undervoltage detection level.</p>	<ul style="list-style-type: none"> • Internal circuit fault. <ul style="list-style-type: none"> → Turn the Inverter OFF and ON. → Change the Inverter if the same fault occurs again.
OH	<p>Radiation fin overheated (OH) The temperature of the radiation fins of the Inverter has reached $110^{\circ}\text{C} \pm 10^{\circ}\text{C}$.</p>	<ul style="list-style-type: none"> • The ambient temperature is too high. <ul style="list-style-type: none"> → Ventilate the Inverter or install a cooling unit. • The load is excessive. <ul style="list-style-type: none"> → Reduce the load. → Decrease the Inverter capacity. • The V/f setting is incorrect. <ul style="list-style-type: none"> → Reduce the V/f set voltage. • The acceleration/deceleration time is too short. <ul style="list-style-type: none"> → Increase the acceleration/deceleration time. • The ventilation is obstructed. <ul style="list-style-type: none"> → Change the location of the Inverter to meet the installation conditions. • The cooling fan of the Inverter does not work. <ul style="list-style-type: none"> → Replace the cooling fan.

Fault display	Fault name and meaning	Probable cause and remedy
OL1	<p>Motor overload (OL1) The electric thermal relay actuated the motor overload protective function. Calculate the heat radiation of the motor from the output current of the Inverter based on the rated motor current (n036), motor protection characteristics (n037), and motor protective time setting (n038).</p>	<ul style="list-style-type: none"> • The load is excessive. → Reduce the load. → Increase the motor capacity. • The V/f setting is incorrect. → Reduce the V/f set voltage. • The value in n11 for maximum voltage frequency is low. → Check the motor nameplate and set n11 to the rated frequency. • The acceleration/deceleration time is too short. → Increase the acceleration/deceleration time. • The value in n036 for rated motor current is incorrect. → Check the motor nameplate and set n036 to the rated current. • The Inverter is driving more than one motor. → Disable the motor overload detection function and install an electronic thermal relay for each of the motors. The motor overload detection function is disabled by setting n036 to 0.0 or n037 to 2. • The motor protective time setting in n038 is short. → Set n038 to 8 (the default value).
OL2	<p>Inverter overload (OL2) The electronic thermal relay has actuated the Inverter overload protective function.</p>	<ul style="list-style-type: none"> • The load is excessive. → Reduce the load. • The V/f setting is incorrect. → Reduce the V/f set voltage. • The acceleration/deceleration time is too short. → Increase the acceleration/deceleration time. • The Inverter capacity is insufficient. → Use an Inverter model with a higher capacity.

Fault display	Fault name and meaning	Probable cause and remedy
OL3	<p>Overtorque detection (OL3) There has been a current or torque the same as or greater than the setting in n098 for overtorque detection level and that in n099 for overtorque detection time. A fault has been detected with n096 for overtorque detection function selection set to 2 or 4.</p>	<ul style="list-style-type: none"> • The mechanical system is locked or has a failure. → Check the mechanical system and correct the cause of overtorque. • The parameter settings were incorrect. → Adjust the n098 and n099 parameters according to the mechanical system. Increase the set values in n098 and n099.
ef□	<p>External fault □ (EF□) An external fault has been input from a multi-function input. A multi-function input 1 to 7 set to 3 or 4 has operated. The EF number indicates the number of the corresponding input (S1 to S7).</p>	<ul style="list-style-type: none"> • An external fault was input from a multi-function input. → Remove the cause of the external fault. • The sequence is incorrect. → Check and change the external fault input sequence including the input timing and NO or NC contact.
f00	<p>Digital Operator transmission fault 1 (F00) No communications were possible with the Digital Operator for 5 s or more after the Inverter had been turned ON.</p>	<ul style="list-style-type: none"> • The Digital Operator may not be mounted properly. → Turn OFF the Inverter, dismount and mount the Digital Operator, and turn ON the Inverter. • The Digital Operator has a failure. → Change the Digital Operator. • The Inverter has a failure. → Change the Inverter.
f01	<p>Digital Operator transmission fault 2 (F01) A transmission fault continued for 5 s or more after communications with the Digital Operator had failed.</p>	<ul style="list-style-type: none"> • The Digital Operator may not be mounted properly. → Turn OFF the Inverter, dismount and mount the Digital Operator, and turn ON the Inverter. • The Digital Operator has a failure. → Change the Digital Operator. • The Inverter has a failure. → Change the Inverter.

Fault display	Fault name and meaning	Probable cause and remedy
f04	<p>Initial memory fault (F04) An error in the built-in EEPROM of the Inverter has been detected.</p>	<ul style="list-style-type: none"> • The internal circuitry of the Inverter has a fault. <ul style="list-style-type: none"> → Initialize the Inverter with n001 set to 8 or 9 and turn the Inverter OFF and ON. → Replace the Inverter if the same fault occurs again.
f05	<p>Analog-to-digital converter fault (F05) An analog-to-digital converter fault has been detected.</p>	<ul style="list-style-type: none"> • The internal circuitry of the Inverter has a fault. <ul style="list-style-type: none"> → Turn the Inverter OFF and ON. → Replace the Inverter if the same fault occurs again.
f06	<p>Option Card fault (F06) An Option Card fault was detected. The Inverter will detect this error if the output or verify signal of the Card has a fault.</p>	<ul style="list-style-type: none"> • The Option Card may not be connected properly. <ul style="list-style-type: none"> → Turn OFF the Inverter, dismount and mount the Option Card or attachment, and turn ON the Inverter. • The Option Card has a failure. <ul style="list-style-type: none"> → Change the Option Card. • The attachment has a failure. <ul style="list-style-type: none"> → Change the attachment.
f07	<p>Digital Operator fault (F07) An error in the built-in control circuit of the Digital Operator has been detected. The EEPROM of the Digital Operator or the analog-to-digital converter has a failure.</p>	<ul style="list-style-type: none"> • The internal circuitry of the Digital Operator has a fault. <ul style="list-style-type: none"> → Turn the Digital Operator OFF and ON. → Replace the Digital Operator if the same fault occurs again.
OPR	<p>Digital Operator connection error (OPR) The Inverter will detect this error if n010 for Digital Operator connection error processing selection is set to 1.</p>	<ul style="list-style-type: none"> • The Digital Operator may not be mounted properly. <ul style="list-style-type: none"> → Turn OFF the Inverter, dismount and mount the Digital Operator, and turn ON the Inverter.

Fault display	Fault name and meaning	Probable cause and remedy
ce	<p>Communications time-over (CE) Normal RS-422/485 communications were not established within 2 s. The Inverter will detect this error if n151 for RS-422/485 communications time over detection selection is set to 0, 1, or 2.</p>	<ul style="list-style-type: none"> • A short-circuit, ground fault, or disconnection has occurred on the communications line. → Check and correct the line. • The termination resistance setting is incorrect. → In the case of RS-422 communications, set pin 1 of SW2 of all Inverters to ON. In the case of RS-485 communications, set pin 1 of SW2 of only the Inverter located at each end of the network to ON. • Noise influence. → Do not wire the communications line along with power lines in the same conduit. → Use the twisted-pair shielded wire for the communications line. • Master's program error. → Check and correct the program so that communications will be performed more than once every 2-s period. • Communications circuit damage. → If the same error is detected as a result of a self-diagnostic test, change the Inverter.
STP	<p>Emergency stop (STP) An emergency stop alarm is input to a multi-function input. (A multi-function input from 1 to 7 that was set to 19 or 21 has operated.)</p>	<ul style="list-style-type: none"> • An emergency stop alarm is input. → Remove the cause of the fault. • The sequence is incorrect. → Check and change the external fault input sequence including the input timing and NO or NC contact.
OFF	<p>Power supply error Control power supply voltage is insufficient.</p>	<ul style="list-style-type: none"> • No power supply is provided. → Check and correct the power supply wire and voltage. • Terminal screws are loose. → Check and tighten the terminal screws. • Operator connectors are faulty. → If only the Operator indicator is not lit, (i.e., if the RUN and ALARM indicators are lit), check and correct the Operator's connectors. • The Inverter is damaged. → Replace the Inverter.

<p>FbL</p>	<p>Feedback loss fault (FbL) A feedback input was interrupted during PID control execution. (This fault is detected when an input level below the feedback loss detection level set in n137 persists for longer than the feedback loss detection time set in n138.)</p>	<ul style="list-style-type: none"> • Feedback wiring error. → Check for and correct any cable disconnection or faulty wiring. • Feedback sensor error → Check sensor status and replace any defective sensors. • PID target value input error or feedback loss detection setting error → Correct the target value input so that it is outside of the feedback loss detection range. Correct the feedback loss detection parameter settings (n137, n138). • Feedback input circuit error → Replace the Inverter.
<p>PF (See note.)</p>	<p>Main circuit voltage fault (PF) The main circuit DC voltage has oscillated erroneously when regeneration was not being performed. This fault is detected when a voltage fluctuation greater than the input open-phase detection level set in n166 persists for longer than the input open-phase detection time set in n167.</p>	<ul style="list-style-type: none"> • Momentary power failure. → Either apply countermeasures against momentary power failures or disable the input open-phase detection. • Input power supply open phase. → Check for and correct any main circuit power supply disconnections or faulty wiring. • Excessive input power supply voltage fluctuation or bad line voltage balance. → Check the power supply voltage. Apply measures to stabilize the power supply, or disable the input open-phase detection. • Main circuit capacitor failure. → If this fault is occurring frequently and there is no error at the power supply, replace the Inverter or disable the input open-phase detection. (Also check the usage time with the accumulated operating time function.)
<p>LF (See note.)</p>	<p>Output open-phase fault (LF) An open phase has occurred at the Inverter's output. This fault is detected when a current in any of the Inverter output phases less than the output open-phase detection level set in n168 persists for longer than the output open-phase detection time set in n169.</p>	<ul style="list-style-type: none"> • Output cable is disconnected. → Check for and correct any output cable disconnections or faulty wiring. • Motor winding disconnected. → Check the motor's line resistance. If winding is broken, replace the motor. • Output terminal screws are loose. → Check and tighten the output terminal screws. • Inverter output transistor open breakdown. → Replace the Inverter.

<p>GF (See note.)</p>	<p>Ground fault (GF) The ground current at the Inverter has exceeded approximately 50% of the Inverter's rated output current.</p>	<ul style="list-style-type: none"> • Motor burnout or insulation damage. → Check the motor's insulation resistance. If conducting, replace the motor. • Cable is damaged. → Check the resistance between the cable and FG. If conducting, replace the cable. • Cable and FG floating capacity → If the cable is longer than 100 m, lower the carrier frequency. → Apply measures to reduce the floating capacity. Don't use metal ducts, use a separate cable for each phase, include an AC reactor in the output side, etc.
<p>SC (See note.)</p>	<p>Load short circuit (SC) The Inverter output or load is short-circuited.</p>	<ul style="list-style-type: none"> • Motor burnout or insulation damage. → Check the resistance between the motor phases. If abnormal, replace the Inverter. • Cable is damaged. → Check the resistance between the cables. If conducting, replace the cable.
<p>BUS</p>	<p>Communications error (Option Unit) A communications error occurred at the Option Unit.</p>	<ul style="list-style-type: none"> • Communications cable wired incorrectly, short-circuited, or disconnected. → Check and correct the communications cable wiring. • Data destroyed by noise. → Change to a dedicated communications cable or to shielded cable, and mask the shield or ground it at the power supply. → Use a dedicated communications power supply, and connect a noise filter to the power supply input side. • Option Unit is damaged. → If communications errors frequently occur and there is no problem with the wiring, replace the Option Unit.

Note This fault is displayed for 200 and 400-V, 5.5-/7.5-kW Inverters only.

8-1-2 Warning Detection (Nonfatal Error)

The warning detection is a type of Inverter protective function that does not operate the fault contact output and returns the Inverter to its original status once the cause of the error has been removed. The Digital Operator flashes and display the detail of the error. If a warning occurs, take appropriate countermeasures according to the table below.

Note Some warnings or some cases stop the operation of the Inverter as described in the table.

■ Warning Displays and Processing

Fault display	Fault name and Meaning	Probable cause and remedy
uU (flashing)	Main circuit undervoltage (UV) The main circuit DC voltage has reached the undervoltage detection level (200 VDC for the 3G3MV-A2□, 160 VDC for the 3G3MV-AB□, and 400 VDC for the 3G3MV-A4□).	<ul style="list-style-type: none"> Power supply to the Inverter has phase loss, power input terminal screws are loose, or the power line is disconnected. → Check the above and take necessary countermeasures. Incorrect power supply voltage → Make sure that the power supply voltage is within specifications.
OU (flashing)	Main circuit overvoltage The main circuit DC voltage has reached the overvoltage detection level (410 VDC for 200-V Inverters, 820 VDC for 400-V Inverters).	<ul style="list-style-type: none"> The power supply voltage is too high. → Decrease the voltage so it will be within specifications.
OH (flashing)	Radiation fin overheated (OH) The temperature of the radiation fins of the Inverter has reached $110^{\circ}\text{C} \pm 10^{\circ}\text{C}$.	<ul style="list-style-type: none"> The ambient temperature is too high. → Ventilate the Inverter or install a cooling unit.
OH3 (flashing)	Warning/Fault contacts do not change state. OH3 (Inverter overheating pre-alarm) OH3 signal is input.	<ul style="list-style-type: none"> Release the input of inverter overheating pre-alarm signal.

Fault display	Fault name and Meaning	Probable cause and remedy
cal (flashing)	<p>Communications standby (CAL)</p> <p>No normal DSR message has been received during RS-422/4895 communications. The Inverter detects this alarm only when RUN command selection (n003) is set to 2 or frequency reference selection (n004) is set to 6. Until the alarm is reset, no input other than communications input will be ignored.</p>	<ul style="list-style-type: none"> • A short-circuit, ground fault, or disconnection has occurred on the communications line. <ul style="list-style-type: none"> → Check and correct the line. • The termination resistance setting is incorrect. <ul style="list-style-type: none"> → In the case of RS-422 communications, set pin 1 of SW2 of all Inverters to ON. In the case of RS-485 communications, set pin 1 of SW2 of only the Inverter located at each end of the network to ON. • Master's program error. <ul style="list-style-type: none"> → Check the start of communications and correct the program. • Communications circuit damage. <ul style="list-style-type: none"> → If the same error is detected as a result of a self-diagnostic test, change the Inverter.

Fault display	Fault name and Meaning	Probable cause and remedy
OP1 (flashing)	Operation error (OP□) (Parameter setting error)	<ul style="list-style-type: none"> The values in n050 through n056 for multi-function inputs 1 through 7 have been duplicated. → Check and correct the values.
OP2 (flashing)		<ul style="list-style-type: none"> The V/f pattern settings do not satisfy the following condition. $n016 \square n014 < n013 \square n011$ → Check and correct the set value.
OP3 (flashing)		<ul style="list-style-type: none"> The rated motor current set in n036 exceeds 150% of the rated output current of the Inverter. → Check and correct the set value.
OP4 (flashing)		<ul style="list-style-type: none"> The frequency reference upper limit set in n036 and the frequency reference lower limit set in n034 do not satisfy the following condition. $n033 \square n034$ → Check and correct the set values.
OP5 (flashing)		<ul style="list-style-type: none"> The jump frequencies set in n083 to n085 do not satisfy the following condition. $n083 \square n084 \square n085$ → Check and correct the set values.
OP9 (flashing)		<ul style="list-style-type: none"> The carrier frequency set in n080 is incorrect. An attempt was made to set a value that is not within a permissible range. → Check and correct the set value.
OL3 (flashing)	Overtorque detection (OL3) There has been a current or torque the same as or greater than the setting in n098 for overtorque detection level and that in n099 for overtorque detection time. A fault has been detected with n096 for overtorque detection function selection set to 1 or 3.	<ul style="list-style-type: none"> The mechanical system is locked or has a failure. → Check the mechanical system and correct the cause of overtorque. The parameter settings were incorrect. → Adjust the n098 and n099 parameters according to the mechanical system. Increase the set values in n98 and n099.

Fault display	Fault name and Meaning	Probable cause and remedy
UL3 (flashing)	<p>ON: Warning UL3 (Undertorque detection) Flashing: fault contacts do not change state. V/f mode: Inverter output current fell below the preset value in constant n118. Vector mode: Motor current or torque fell below the preset value in constants n097 and n118.</p>	<ul style="list-style-type: none"> • Load (output current or output torque) is too low. → Check the driven machine and correct the cause of the fault, or decrease the value of constant n118 up to the lowest value allowed for the machine.
UL3	<p>OFF: Protective operation ON: Output is shut OFF and motor coasts to a stop. When undertorque is detected, inverter performs operation according to the preset setting of constant n117.</p>	
ser (flashing)	<p>Sequence error (SER) A sequence change has been input while the Inverter is in operation. Local or remote selection is input while the Inverter is in operation. Note The Inverter coasts to a stop.</p>	<ul style="list-style-type: none"> • A sequence error has occurred. → Check and correct the sequence.
bb (flashing)	<p>External base block (bb) The external base block command has been input. Note The Inverter coasts to a stop.</p>	<ul style="list-style-type: none"> • The external base block command has been input. → Remove the cause of external base block input. • The sequence is incorrect. → Check and change the external fault input sequence including the input timing and NO or NC contact.

Fault display	Fault name and Meaning	Probable cause and remedy
ef (flashing)	Forward- and reverse-rotation input (EF) The forward and reverse commands are input to the control circuit terminals simultaneously for 0.5 s or more. Note The Inverter stops according to the method set in n04.	• A sequence error has occurred. → Check and adjust the local or remote selection sequence.

Fault display	Fault name and Meaning	Probable cause and remedy
<p>SfP (flashing)</p>	<p>Emergency stop (STP) The Digital Operator stops operating. The STOP/RESET Key on the Digital Operator is pressed while the Inverter is operating according to the forward or reverse command through the control circuit terminals. Note The Inverter stops according to the method set in n04. The emergency stop alarm signal is input as multi-function input. A multi-function input 1 to 7 set to 20 or 22 has been used. Note The Inverter stops according to the method set in n005. The Inverter decelerates to a stop in deceleration time 2 with n005 set to 0.</p>	<ul style="list-style-type: none"> • The parameter setting was incorrect. → Check that the n007 parameter setting for STOP/RESET Key function selection is correct. • An emergency stop alarm is input to a multi-function input. → Remove the cause of the fault or correct the input sequence.
<p>FAn (flashing)</p>	<p>Cooling fan fault (FAN) The cooling fan has been locked.</p>	<ul style="list-style-type: none"> • The cooling fan wiring has a fault. → Turn OFF the Inverter, dismount the fan, and check and repair the wiring. • The cooling fan is not in good condition. → Check and remove the foreign material or dust on the fan. • The cooling fan is beyond repair. → Replace the fan.

Fault display	Fault name and Meaning	Probable cause and remedy
FbL (flashing)	<p>Feedback loss fault (FbL) A feedback input was interrupted during PID control execution. (This fault is detected when an input level below the feedback loss detection level set in n137 persists for longer than the feedback loss detection time set in n138.)</p>	<ul style="list-style-type: none"> • Feedback wiring error. → Check for and correct any cable disconnection or faulty wiring. • Feedback sensor error → Check sensor status and replace any defective sensors. • PID target value input error or feedback loss detection setting error → Correct the target value input so that it is outside of the feedback loss detection range. Correct the feedback loss detection parameter settings (n137, n138). • Feedback input circuit error → Replace the Inverter.
oH3	<p>Inverter overheating warning (oH3) An Inverter overheating warning signal was input from an external control terminal set to multi-function input.</p>	<ul style="list-style-type: none"> • Clear the Inverter overheating warning signal. • Eliminate the cause of the warning signal input.
CE	<p>Communications time over (CE) RS-422 or RS-485 communications were not properly carried out within 2 s. (Detected when n151 is set to "3.")</p>	<ul style="list-style-type: none"> • A short-circuit, ground fault, or disconnection has occurred on the communications line. → Check and correct the line. • The termination resistance setting is incorrect. → In the case of RS-422 communications, set pin 1 of SW2 of all Inverters to ON. In the case of RS-485 communications, set pin 1 of SW2 of only the Inverter located at each end of the network to ON. • Noise influence. → Do not wire the communications line along with power lines in the same conduit. → Use the twisted-pair shielded wire for the communications line, and ground it at the Master. • Master's program error. → Check and correct the program so that communications will be performed more than once every 2-s period. • Communications circuit damage. → If the same error is detected as a result of a self-diagnostic test, change the Inverter.

8-2 Troubleshooting

Due to parameter setting errors, faulty wiring, and so on, the Inverter and motor may not operate as expected when the system is started up. If that should occur, use this section as a reference and apply the appropriate measures.

Refer to *8-1 Protective and Diagnostic Functions*, if the contents of the fault are displayed,

8-2-1 Parameters Fail Set

■ The display does not change when the Increment or Decrement Key is pressed.

- Parameter write-prohibit is input.

This occurs when n001 for parameter write-prohibit selection/parameter initialization is set to 0. Set n001 to an appropriate value according to the parameter to be set.

- The Inverter is operating.

There are some parameters that cannot be set during operation. Refer to the list of parameters. Turn the Inverter OFF and then make the settings.

■ “OP□” is displayed.

A parameter setting error has occurred. Refer to *8-1-2 Warning Detection (Nonfatal Error)* and make the necessary corrections.

■ Nothing is displayed on the Digital Operator or “OPR” is displayed.

A connection error has occurred in the Digital Operator.

Turn OFF the Inverter and dismount the Digital Operator. After checking that the connector is free of any foreign material remount the Digital Operator.

8-2-2 Motor Fails to Operate

■ The motor does not operate with input through the control circuit terminals even though the frequency reference is correct.

- The operation method setting is incorrect.

If parameter n003 for operation mode selection is not set to 1 to enable the control circuit terminals, the RUN command cannot be executed through the control circuit terminals.

Check and correct the setting in n003.

- Input in 2-wire sequence while 3-wire sequence is in effect and vice-versa.

The Inverter will operate in 3-wire sequence according to the RUN, stop, and forward/stop commands if n052 for multi-function input 3 is set to 0. At that time, the Inverter will not operate if input in 2-wire sequence is ON. On the other hand, the Inverter in 2-wire sequence will only rotate in the reverse direction if input in 3-wire sequence is ON.

Check and correct the setting in n052 or change the input method of the RUN command.

- The Inverter is not in RUN mode.

When the PRGM or LO/RE indicator (red indicator) of the Digital Operator is lit, the Inverter does not start.

Cancel the RUN command, and by pressing the Mode Key, turn ON the green indicator before restarting the Inverter.

- The value of the frequency reference is too low.

The Inverter will have no output if the frequency reference is below the minimum output frequency in n016.

Set the frequency reference to exceed the minimum output frequency.

- The Inverter is in local mode.

The RUN command can be given to the Inverter in local mode only with the RUN Key of the Digital Operator. Check the LO/RE indicator. If “Lo” is displayed, the Inverter is in local mode. Press the Increment Key so that “rE” will be displayed.

If the above operation is not possible, multi-function input will be set to local/remote selection. In that case, the mode can be switched only through the corresponding multi-function input terminal. Set the input terminal to OFF so that the Inverter will be in remote mode.

- The input wiring of the control circuit terminals of the Inverter is incorrect.

The Inverter cannot check the input signal if the input line of the control circuit terminals is incorrectly wired. Use the Digital Operator and check the setting in multi-function monitor U-96 for the input terminal status.

The default setting for Inverter input is to NPN sequence input, which can be changed to PNP sequence input. Refer to *2-2-1 Terminal Block* and check that the SW1 settings conform with the actual wiring.

■ The motor does not turn with input through the control terminals. (The frequency reference is set to zero or different from the set value.)

- The setting of the frequency reference is incorrect.

The frequency reference through analog input will be ignored if the Digital Operator has been selected for frequency reference settings. The frequency reference through digital input will be ignored if the Digital Operator has not been selected.

Check that the set value in n004 for frequency reference selection matches the actual method used.

When using analog input, refer to *2-2-1 Terminal Block* and check that the SW2 settings conform with the actual input (voltage or current).

- The Inverter is in local mode.

The frequency reference can be given to the Inverter in local mode only with the FREQUENCY adjuster or through a key sequence on the Digital Operator.

Check the LO/RE indicator. If “Lo” is displayed, the Inverter is in local mode. Press the Increment Key so that “rE” will be displayed.

If the above operation is not possible, multi-function input will be set to local/remote selection. In that case, the mode can be switched only through the corresponding multi-function input terminal. Set the input terminal to OFF so that the Inverter will be in remote mode.

- The gain and bias settings of the analog input are incorrect.

Check that the frequency reference gain in n060 and the frequency reference bias in n061 conform with the actual analog input characteristics.

- The auxiliary frequency reference and frequency gain are not input by the multi-function analog inputs.

If frequency reference 2 is selected when an auxiliary frequency reference is set for a multi-function analog input, the analog value of the multi-function analog input will become the frequency reference. Also, if the frequency gain is set, the specified frequency will be multiplied by a factor proportional to the analog value of the multi-function input. In either case, if no analog voltage is input by the multi-function analog input, the Inverter will not operate. Check the multi-function analog input terminal parameters (n077, n078) and the wiring.

■ The motor stops during acceleration or when a load is connected.

- The load may be too big.

The 3G3MV has a stall prevention function and automatic torque boost function, but the motor responsiveness limit may be exceeded if acceleration is too rapid or if the load is too big.

Lengthen the acceleration time or reduce the load. Also consider increasing the motor capacity.

■ **The motor only rotates in one direction.**

- Reverse rotation-prohibit is selected.

If n006 for reverse rotation-prohibit selection is set to 1 (reverse run prohibited), the Inverter will not accept reverse-rotation commands.

To use both forward and reverse rotation, set n05 to 0.

8-2-3 Motor Rotates in the Wrong Direction

- The output wiring of the motor is faulty.

When the U, V, and W terminals of the Inverter are properly connected to the U, V and W terminals of the motor, the motor will operate in a forward direction when a forward rotation command is executed. The forward direction depends on the manufacturer and the motor type. Therefore, be sure to check the specifications.

Switching two wires among the U, V, and W will reverse the direction of rotation.

8-2-4 Motor Outputs No Torque or Acceleration is Slow

- The Inverter in vector control is restricted by the torque compensation limit.

If the torque compensation limit in n109 is set to a value that is too small, the motor torque will be limited to a low value and sufficient torque will not be available.

If no torque restriction is required, set the parameter to a range from 150% (default setting) to 200%.

- The stall prevention level during running is too low.

If the value in n093 for stall prevention level during operation is too low, the speed will drop before torque output is turned ON.

Check to be sure that the set value is suitable.

- The stall prevention level during acceleration is too low.

If the value in n094 for stall prevention level during acceleration is too slow, the acceleration time will be too long.

Check to be sure that the set value is suitable.

- V/f Control Limit

Unlike vector control, the output torque of the Inverter in V/f control is low at low frequencies. Consider the use of vector control if higher output torque at low frequencies is required.

8-2-5 Speed Accuracy of the Inverter Rotating at High Speed in Vector Control is Low

- The rated motor voltage is high.

The maximum output voltage of the Inverter is determined by the voltage of input into the Inverter. If the input is at 200 VAC, for example, the maximum output voltage will be 200 VAC. The speed precision of the Inverter will drop if the output voltage designated by vector control has exceeded the maximum output voltage of the Inverter.

Use a motor with a lower rated voltage (e.g., a dedicated motor for vector control use).

8-2-6 Motor Deceleration Rate is Low

- Stall prevention during deceleration is set.

When connecting the Braking Resistor Unit or a braking resistor as a braking option, set n092 for Stall prevention during deceleration to 1 so that stall prevention will be disabled. If n092 is set to 0 (default setting), the Braking Resistor Unit or a braking resistor connected will not be used. Therefore, there will be no reduction in the deceleration time.

- The deceleration time setting is too long.

Check the deceleration time settings in n020 and n022.

- Motor torque is insufficient.

If the parameter constants are correct and there is no overvoltage fault, the power the motor will be limited.

Consider increasing the motor capacity.

- The Inverter in vector control is restricted by the torque compensation limit.

If the torque compensation limit in n109 is set to a value that is too small, the motor torque will be limited to a low value and sufficient torque will not be available.

If no torque restriction is required, set the parameter to a range from 150% (default setting) to 200%.

8-2-7 Vertical-axis Load Drops when Brakes are Applied

- The sequence is incorrect.

The Inverter goes into DC braking status for 0.5 s after deceleration is completed. This is the default setting.

Check the sequence to make sure that the brake is applied with DC braking status or adjust the value n090 for DC injection control time.

- The DC injection braking is insufficient.
If the DC braking power is insufficient, adjust the value in n089 for DC injection control current.
- An inappropriate brake is being used.
Use a brake intended for braking rather than holding.

8-2-8 Motor Burns

- The load is too big.
If the load of the motor is too big and the motor is used with the effective torque exceeding the rated torque of the motor, the motor will burn out. For example, the rated torque of the motor and capacity may be limited to eight hours of use if the inscription on the motor states that the motor is rated for eight hours. If the 8-hour rated torque is used for normal operation, it may cause the motor to burn out.
Reduce the load amount by either reducing the load or lengthening the acceleration/ deceleration time. Also consider increasing the motor capacity.
- The ambient temperature is too high.
The rating of the motor is determined within a particular ambient operating temperature range. The motor will burn out if it runs continuously at the rated torque in an environment in which the maximum ambient operating temperature is exceeded.
Lower the ambient temperature of the motor to within the acceptable ambient operating temperature range.
- The withstand voltage between the phases of the motor is insufficient.
When the motor is connected to the output of the Inverter, a surge will be generated between the switching of the Inverter and the coil of the motor.
Normally, the maximum surge voltage is approximately three times the input power supply voltage of the Inverter (i.e., approximately 600 V for 200-V Inverters, 1,200 V for 400-V Inverters).
Therefore, the dielectric strength of the motor to be used must be higher than the maximum surge voltage.
In particular, use a dedicated motor for 400-V Inverters.

8-2-9 Controller or AM Radio Receives Noise when Inverter is Started

- Noise derives from Inverter switching.

Take the following actions to prevent noise.

- Lower the carrier frequency of the Inverter in n080.

The number of internal switching times is reduced, so noise can be reduced to some extent.

- Install an Input Noise Filter.

Install an Input Noise Filter on the power input area of the Inverter.

- Install an Output Noise Filter.

Install an Output Noise Filter on the output area of the Inverter.

- Use metal tubing.

Electric waves can be shielded by metal. Therefore, enclose the Inverter with a metal tube.

8-2-10 Ground Fault Interrupter is Actuated when Inverter is Started

- Leakage current flows through the Inverter.

The Inverter performs internal switching. Therefore, a leakage current flows through the Inverter. This leakage current may actuate the ground fault interrupter, shutting the power OFF.

Use a ground fault interrupter with a high leakage-current detection value (sensitivity amperage of 200 mA or more, operating time of 0.1 s or more) or one with high-frequency countermeasures for Inverter use.

Reducing the carrier frequency value in n080 is also effective.

In addition, remember that a leakage current increases in proportion to the cable length. Normally, approximately 5 mA of leakage current is generated for each meter of cable.

8-2-11 Mechanical Vibration

■ Mechanical system makes unusual noise.

- Resonance between the characteristic frequency of the mechanical system and the carrier frequency.

There may be resonance between the characteristic frequency of the mechanical system and the carrier frequency. If the motor is running with no problems and the machinery system is vibrating with a high-pitched whine, it may indicate that this is occurring. To prevent this type of resonance, adjust the carrier frequency value in n080.

- Resonance between the characteristic frequency of a machine and the output frequency of the Inverter.

There may be resonance between the characteristic frequency of a machine and the output frequency of the Inverter. To prevent this from occurring, use the frequency jump function with the constants set in n083 through n086 to change the output frequency or install vibration-proof rubber on the motor base to prevent the resonance of the mechanical system.

■ Vibration and hunting are occurring.

- Influence by the torque compensation function or the slip compensation function.

The torque compensation function or the slip compensation function of the Inverter may influence the characteristic frequency of the mechanical system, causing vibration or hunting. In that case, increase the time constants in n104 for torque compensation and in n112 for slip compensation. The larger these time constants are, however, the slower the response speed of the torque compensation function and slip compensation function will be.

■ Motor vibrates excessively and does not rotate normally.

- Motor Phase Interruption

If one or two of the three phases of the motor are open, the motor will vibrate excessively and will not rotate. Check that the motor is wired correctly without any disconnection. The same phenomenon will occur if the output transistor of the Inverter is open and damaged. Check the balance of the Inverter's output voltage as well.

8-2-12 Stable PID Control is Not Possible or Control Fails

■ PID control is not possible with vibration or hunting.

- PID control gain adjustment is insufficient.

Check the frequency of vibration and adjust the proportional (P) control, integral (I) control, and derivative (D) control of the Inverter. Refer to *6-3-7 PID Adjustments*.

■ PID control diverges.

- No feedback is input.

If the detected value is 0 with no feedback input, the PID control function will not operate. As a result, the output of the Inverter will diverge and the motor will increase its speed up to the maximum frequency.

Check that the set value in n164 for PID feedback input block selection conforms with the actual input and that the PID constants are set properly. Refer to *6-3-6 PID Control Settings*.

- Level adjustments of the target and detected values are imperfect.

The Inverter in PID control adjusts the deviation between the target and detected values so that the deviation will be zero. Therefore, the target and detected values must be adjusted so that they will have the same input level. Set the detected value gain in n129 after making the proper level adjustments.

- The relationship between the output frequency and detected value of the Inverter is opposite.

PID control will result in diversion if the detected value decreases when the output frequency of the Inverter increases. If that happens, set n128 for PID control selection to negative characteristics (e.g., if 1 has been set, change it to 5).

8-2-13 Inverter Vibrates in Energy-saving Control

- The energy-saving settings are incorrect.

Check the frequency of vibration.

If the frequency coincides with the power averaging time in n143, the Inverter is not in smooth probe operation. Set the probe operation voltage limit to 0 in n144 to disable the probe operation of the Inverter or reduce the set values of n145 (100% probe-control voltage step) and n146 (5% probe-control voltage step) so that the voltage change range will be narrower.

8-2-14 Motor Rotates after Output of Inverter is Turned OFF

- Insufficient DC Control

If the motor continues operating at low speed, without completely stopping, and after a deceleration stop has been executed, it means that the DC braking is not decelerating enough.

In such cases, adjust the DC control as described below.

- Increase the parameter in n089 for DC injection control current.
- Increase the parameter in n090 for DC injection control time.

8-2-15 Detects 0 V and Stalls when Motor Starts

- Insufficient DC control at startup

Generation of 0 V and stalling can occur if the motor is turning when it is started.

This can be prevented by slowing the rotation of the motor by DC braking before starting the motor.

Increase the parameter in n091 for startup DC injection control time.

8-2-16 Output Frequency Does Not Reach Frequency Reference

- The frequency reference is within the jump frequency range.

If the jump function is used, the output frequency stays within the jump frequency range.

Make sure that the jump width settings in n083 through n085 for jump frequencies 1 through 3 and jump width in n086 are appropriate.

- The preset output frequency exceeds the upper-limit frequency.

The upper-limit frequency can be obtained from the following formula.

Maximum frequency in n011 × frequency reference upper limit in n033/100

Make sure that the parameters in n011 and n033 are correct.

8-2-17 Inverter Does Not Run Because EF (Simultaneous Inputs of Forward and Reverse Commands) is Detected, Or Motor Rotates Momentarily When Control Device Power is Turned OFF

■ Sequence Error





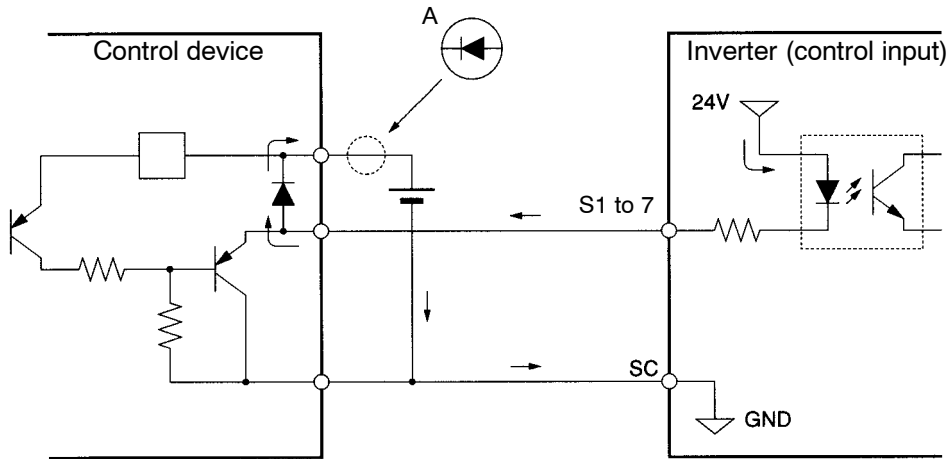

An EF will be detected if a forward command and a reverse command are input simultaneously for 0.5 seconds or longer. Correct the sequence.

■ Malfunction Due to Unwanted Current Path

Inverter inputs may remain ON due to an unwanted current path for the controller outputs. With the wiring shown in the following table, if the controller output power supply is less than 24 V DC or if the power is OFF, the current indicated by the arrow will flow and the Inverter inputs will operate. If that occurs, insert a diode as shown in the diagram at point A.



8-3 Maintenance and Inspection

-  **WARNING** Do not touch the Inverter terminals while the power is being supplied.
-  **WARNING** Maintenance or inspection must be performed only after turning OFF the power supply, confirming that the CHARGE indicator (or status indicators) is turned OFF, and after waiting for the time specified on the front cover. Not doing so may result in electrical shock.
-  **WARNING** Maintenance, inspection, or parts replacement must be performed by authorized personnel. Not doing so may result in electrical shock or injury.
-  **WARNING** Do not attempt to take the Unit apart or repair. Doing either of these may result in electrical shock or injury.
-  **Caution** Carefully handle the Inverter because it uses semiconductor elements. Careless handling may result in malfunction.
-  **Caution** Do not change wiring, disconnect connectors or Operator, or replace fans while power is being supplied. Doing so may result in injury or malfunction.

■ Daily Inspection

Check the following items with the system in operation.

- The motor should not be vibrating or making unusual noises.
- There should be no abnormal heat generation.
- The output current value shown on the monitor display should not be higher than normal.
- The cooling fan on the bottom of the Inverter should be operating normally, if the Inverter model has the cooling fan.

■ Periodic Inspection

Check the following items during periodic maintenance.

Before beginning inspection, be sure to turn OFF the power supply. Confirm that all the indicators on the front panel have turned OFF, and then wait until at least 1 minute has elapsed before beginning the inspection.

Be sure not to touch the terminals right after the power has been turned OFF. Otherwise, an electric shock may occur.

- The terminal screws of the Inverter should not be loose.
- There should be no conductive dust or oil mist on the terminal block or inside the Inverter.
- The mounting screws of the Inverter should not be loose.
- No dirt or dust should be accumulating on the radiation fin.
- No dust should be accumulating on the vents of the Inverter.
- There should be no abnormalities in the outward appearance of the Inverter.
- There should be no unusual noises or vibration and the accumulated operating time should not exceed the specifications.

■ Periodic Maintenance Parts

Periodic inspection standards vary with the installation environment and usage conditions of the Inverter.

The maintenance periods of the Inverter are described below. Keep them as reference.

Maintenance Periods (Reference)

- Cooling fan: 2 to 3 years
- Electrolytic capacitor: 5 years
- Fuse: 10 years

The usage conditions are as follows:

- Ambient temperature: 40°C
- Load factor: 80%
- Operation: 8 hours per day
- Installation: According to instructions in manual

It is recommended that the ambient temperature and power-on time be reduced as much as possible to extend the life of the Inverter.

Note For details regarding maintenance, consult your OMRON representative.

■ Replacement of Cooling Fan

If the FAN fault is displayed or the cooling fan needs replacement, take the following steps to replace it.

● Cooling Fan Models

	Inverter	Cooling Fan
3-phase 200-VAC	3G3MV-A2007	3G3IV-PFAN2007
	3G3MV-A2015	3G3IV-PFAN2015M
	3G3MV-A2022	3G3IV-PFAN2022
	3G3MV-A2040	3G3IV-PFAN2037
	3G3MV-A2055/-A2075	3G3IV-PFAN2037 (2 parts)
Single-phase 200-VAC	3G3MV-AB015	3G3IV-PFAN2015M
	3G3MV-AB022	3G3IV-PFAN2037
	3G3MV-AB040	3G3IV-PFAN2037 (2 parts)
3-phase 400-VAC	3G3MV-A4015/-A4022	3G3IV-PFAN2015M
	3G3MV-A4030/-A4040	3G3IV-PFAN2037
	3G3MV-A4055/-A4075	3G3IV-PFAN2037 (2 parts)

● Replacing Cooling Fan of 68-mm-wide Inverter Model

1. Press the left and right sides of the fan cover located on the lower part of the radiation fin in the arrow 1 directions. Then lift the bottom of the Fan in the arrow 2 direction to remove the Fan as shown in the following illustration.

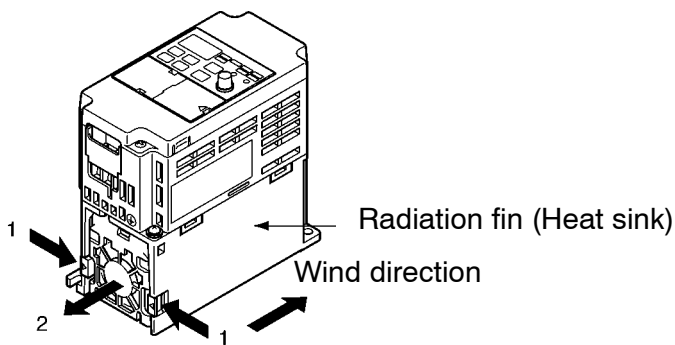

2. Hold the fan wire and pull the protective tube of the cover in the arrow 3 direction.

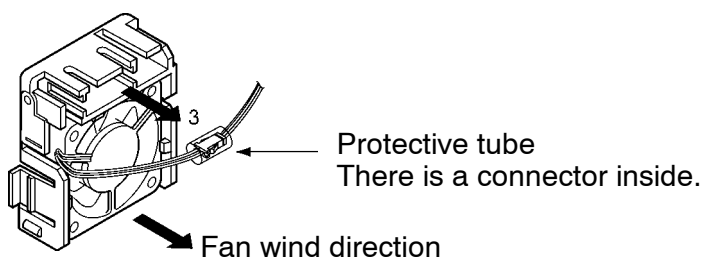

3. Slide the protective tube and remove the internal connector.

4. Remove the Fan from the fan cover.
5. Mount the new Fan on the fan cover. At this time, make sure that the wind direction of the Fan will be in the direction of the heat radiation fin.
6. Attach the connector, cover the connector with the protective tube, and insert the connector into the cover.
7. Mount the fan cover with the new Fan to the lower part of the heat radiation fin. Make sure that the fan cover snaps on securely with the heat radiation fin.

● **Replacing Cooling Fan of 108-mm-wide Inverter Model**

1. Dismount the front cover, bottom cover, and fan connector CN4.

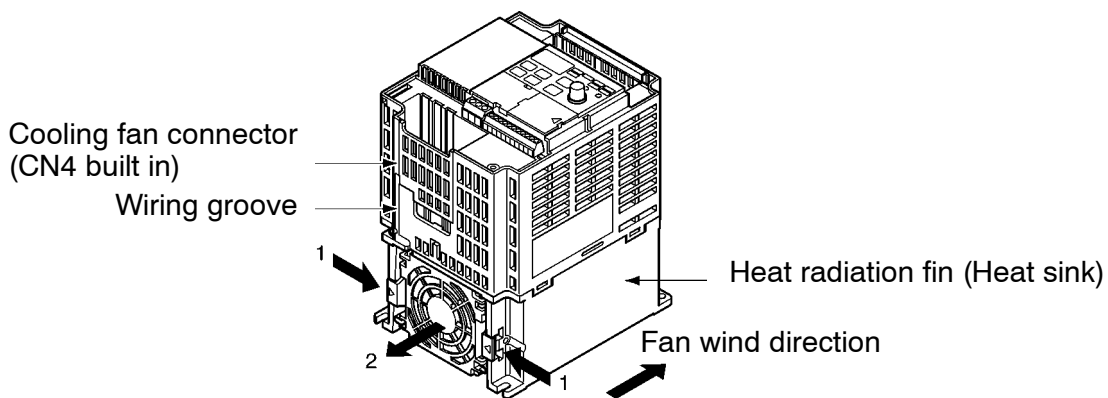

2. Press the left and right sides of the fan cover located on the lower part of the radiation fin in the arrow 1 directions. Then lift the bottom of the Fan in the arrow 2 direction to remove the fan as shown in the following illustration.
Disconnect the wire from the electrical inlet on the bottom of the plastic casing.
3. Remove the Fan from the fan cover.
4. Mount the new Fan on the fan cover. At this time, make sure that the wind direction of the fan will be in the direction of the heat radiation fin.
5. Mount the fan cover with the new Fan to the lower part of the heat radiation fin. Make sure that the fan cover snaps on securely with the heat radiation fin.
6. Wire the power line through the electrical inlet on the bottom of the plastic casing and the wiring groove into the internal circuitry of the Inverter.
7. Attach the wire to connector CN10 and attach the bottom cover and front cover.

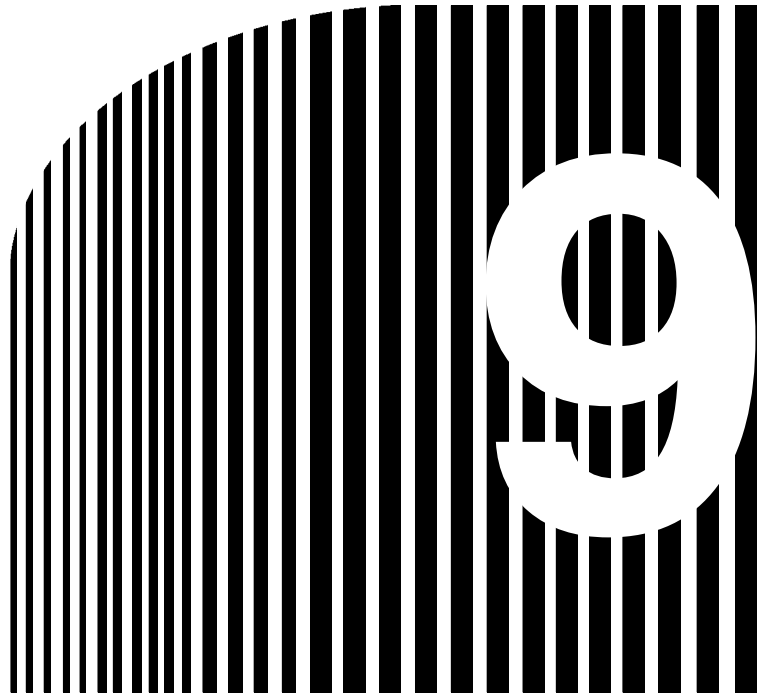

Chapter 9

• Specifications •

9-1 Inverter Specifications

9-2 Option Specifications

9-1 Inverter Specifications

■ 200-V-class Inverters

3-phase 200-VAC models	Model 3G3MV-		A2001	A2002	A2004	A2007	A2015	A2022	A2040	A2055	A2075	
	Power supply	Rated voltage and frequency	3-phase 200 to 230 VAC at 50/60 Hz									
		Allowable voltage fluctuation	-15% to 10%									
		Allowable frequency fluctuation	±5%									
		Input power supply capacity	0.4	0.9	1.6	2.7	4.3	5.9	9.3	13.3	17.6	
	Heat radiation (W) (see note 2)		13.0	18.0	28.1	45.1	72.8	94.8	149.1	249.8	318.1	
	Weight (kg)		0.6	0.6	0.9	1.1	1.4	1.5	2.1	4.6	4.8	
	Cooling method		Natural cooling				Cooling fan					

Single-phase 200-VAC models	Model 3G3MV-		AB001	AB002	AB004	AB007	AB015	AB022	AB040	---	---	
	Power supply	Rated voltage and frequency	Single-phase 200 to 240 VAC at 50/60 Hz									
		Allowable voltage fluctuation	-15% to 10%									
		Allowable frequency fluctuation	±5%									
		Input power supply capacity	0.5	0.9	1.6	2.7	4.3	5.9	9.3	---	---	
	Heat radiation (W) (see note 2)		14.1	20.0	31.9	51.4	82.8	113.6	176.4	---	---	
	Weight (kg)		0.6	0.7	1.0	1.5	1.5	2.2	2.9	---	---	
	Cooling method		Natural cooling				Cooling fan					

Max. applicable motor capacity (kW)		0.1	0.25	0.55	1.1	1.5	2.2	4.0	---	---	
Output specifications	Rated output capacity (kVA)	0.3	0.6	1.1	1.9	3.0	4.2	6.7	9.5	13	
	Rated output current (A)	0.8	1.6	3.0	5.0	8.0	11.0	17.5	25	33	
	Rated output voltage (V)	3-phase 200 to 240 VAC (according to the input voltage)									
	Max. output frequency	400 Hz parameter setting									

Control characteristics	Harmonic-current countermeasures	DC reactor (option) connection possible
	Control method	Sine wave PWM (V/f control)
	Carrier frequency	2.5 to 10.0 kHz (in vector control)
	Frequency control range	0.1 to 400 Hz
	Frequency precision (temperature characteristics)	Digital commands: $\pm 0.01\%$ (-10°C to 50°C) Analog commands: $\pm 0.5\%$ ($25^{\circ}\text{C} \pm 10^{\circ}\text{C}$)
	Frequency setting resolution	Digital commands: 0.1 Hz (less than 100 Hz) and 1 Hz (100 Hz or over) Analog commands: 0.06 Hz/60 Hz (equivalent to 1/1000)
	Output frequency resolution	0.01 Hz
	Overload capacity	150% of rated output current for 1 min
	External frequency set signal	Selectable with FREQ adjuster: 0 to 10 VDC (20 k Ω), 4 to 20 mA (250 Ω), and 0 to 20 mA (250 Ω)
	Acceleration/deceleration time	0.01 to 6,000 s (Independent acceleration and deceleration time settings: 2 types)
	Braking torque	Approx. 20% (125 to 150% possible with braking resistor)
	Voltage/frequency characteristics	Set voltage vector control/user V/f pattern
Protective functions	Motor protection	Protection by electronic thermal
	Instantaneous overcurrent protection	Stops at approx. 250% of rated output current
	Overload protection	Stops in 1 min at approximately 150% of rated output current
	Overvoltage protection	Stops when main-circuit DC voltage is approximately 410 V
	Undervoltage protection	Stops when main-circuit DC voltage is approximately 200 V (160 V for single-phase 200-VAC model)
	Momentary power interruption compensation (selection)	Stops for 15 ms or more. By setting the Inverter to momentary power interruption mode, operation can be continued if power is restored within approximately 0.5 s.
	Cooling fan overheating	Detects at $110^{\circ}\text{C} \pm 10^{\circ}\text{C}$
	Grounding protection	Protection at overcurrent detection level
	Charge indicator (RUN indicator)	Lit when the main circuit DC voltage is approximately 50 V or less.

Environment	Location	Indoors (with no corrosive gas, oil spray, or metallic dust)	
	Ambient storage temperature	-20°C to 60°C	
	Ambient humidity	Operating: 90% max. (with no condensation)	
	Ambient operating temperature	Panel-mounting: -10°C to 50°C	Closed wall-mounting: -10°C to 40°C
	Altitude	1,000 m max.	
	Insulation resistance	5 MΩ min. (Do not carry out any insulation resistance or withstand voltage tests)	
	Vibration resistance	9.8 m/s ² {1G} max. between 10 to 20 Hz 2.0 m/s ² {0.2G} max. between 20 and 50 Hz	
Degree of protection	Panel-mounting models: Conforms to IP20	See note 3	

Note 1. The power supply capacity is the capacity for the Inverter’s rated output. It will vary depending on the impedance at the input power supply. (This is due to fluctuations in the power factor. The power factor can be improved by inserting an AC reactor.) There will also be variations in the ratio between the rated current of the motor that is used and the rated output current of the Inverter.

Note 2. The heat radiation is the electric power consumed in the Inverter at the Inverter’s rated output.

Note 3. The 5.5- and 7.5-kW Inverters are closed wall-mounting models (NEMA1/IP20) as a standard, but they can be converted to panel-mounting (IP00) by removing the top and bottom covers.

■ 400-V-class Inverters

3-phase 400-VAC models	Model 3G3MV-	A4002	A4004	A4007	A4015	A4022	A4030	A4040	A4055	A4075
	Power supply	Rated voltage and frequency	3-phase 380 to 460 VAC at 50/60 Hz							
	Allowable voltage fluctuation	-15% to 10%								
	Allowable frequency fluctuation	±5%								
	Input power supply capacity (see note 1)	1.3	1.9	3.6	5.1	5.9		9.1	15.8	19.2
	Heat radiation (W) (see note 2)	23.1	30.1	54.9	75.7	83.0	95.8	129.1	256.5	308.9
	Weight (kg)	1.0	1.1	1.5	1.5	1.5	2.1	2.1	4.8	4.8
	Cooling method	Natural cooling			Cooling fan					

Max. applicable motor capacity (kW)		0.37	0.55	1.1	1.5	2.2	3.0	4.0	5.5	7.5
Output specifications	Rated output capacity (kVA)	0.9	1.4	2.6	3.7	4.2	5.5	7.0	11	14
	Rated output current (A)	1.2	1.8	3.4	4.8	5.5	7.2	9.2	14.8	18
	Rated output voltage (V)	3-phase 380 to 460 VAC (according to the input voltage)								
	Max. output frequency	400 Hz parameter setting								
Control characteristics	Harmonic-current countermeasures	DC reactor (option) connection possible								
	Control method	Sine wave PWM (V/f control)								
	Carrier frequency	2.5 to 10.0 kHz (in vector control)								
	Frequency control range	0.1 to 400 Hz								
	Frequency precision (temperature characteristics)	Digital commands: $\pm 0.01\%$ (-10°C to 50°C) Analog commands: $\pm 0.5\%$ ($25^{\circ}\text{C} \pm 10^{\circ}\text{C}$)								
	Frequency setting resolution	Digital commands: 0.1 Hz (less than 100 Hz) and 1 Hz (100 Hz or over) Analog commands: 0.06 Hz/60 Hz (equivalent to 1/1000)								
	Output frequency resolution	0.01 Hz								
	Overload capacity	150% of rated output current for 1 min								
	External frequency set signal	Selectable with FREQ adjuster: 0 to 10 VDC (20 k Ω), 4 to 20 mA (250 Ω), and 0 to 20 mA (250 Ω)								
	Acceleration/deceleration time	0.01 to 6,000 s (Independent acceleration and deceleration time settings)								
	Braking torque	Approx. 20% (125 to 150% possible with braking resistor: 2 types)								
Voltage/frequency characteristics	Set voltage vector control/user V/f pattern									

Protective functions	Motor protection	Protection by electronic thermal	
	Instantaneous overcurrent protection	Stops at approx. 250% of rated output current	
	Overload protection	Stops in 1 min at approximately 150% of rated output current	
	Overvoltage protection	Stops when main-circuit DC voltage is approximately 820 V	
	Undervoltage protection	Stops when main-circuit DC voltage is approximately 400 V	
	Momentary power interruption compensation (selection)	Stops for 15 ms or more. By setting the Inverter to momentary power interruption mode, operation can be continued if power is restored within approximately 0.5 s.	
	Cooling fin overheating	Detects at 110°C ± 10°C	
	Grounding protection	Protection at overcurrent detection level	
	Charge indicator (RUN indicator)	Lit when the main circuit DC voltage is approximately 50 V or less.	
Environment	Location	Indoors (with no corrosive gas, oil spray, or metallic dust)	
	Ambient operating temperature	Panel-mounting: -10°C to 50°C	Closed wall-mounting: -10°C to 40°C
	Ambient humidity	Operating: 90% max. (with no condensation)	
	Ambient storage temperature	-20°C to 60°C	
	Altitude	1,000 m max.	
	Insulation resistance	5 MΩ min. (Do not carry out any insulation resistance or withstand voltage tests)	
	Vibration resistance	9.8 m/s ² {1G} max. between 10 to 20 Hz 2.0 m/s ² {0.2G} max. between 20 and 50 Hz	
Degree of protection	Panel-mounting models: Conforms to IP20	See note 3	

Note 1. The power supply capacity is the capacity for the Inverter’s rated output. It will vary depending on the impedance at the input power supply. (This is due to fluctuations in the power factor. The power factor can be improved by inserting an AC reactor.) There will also be variations in the ratio between the rated current of the motor that is used and the rated output current of the Inverter.

Note 2. The heat radiation is the electric power consumed in the Inverter at the Inverter’s rated output.

Note 3. The 5.5- and 7.5-kW Inverters are closed wall-mounting models (NEMA1/IP20) as a standard, but they can be converted to panel-mounting (IP00) by removing the top and bottom covers.

Initial settings, depending on inverter capacity

■ 200V class 3-phase

No.	Name	Unit									
-	Inverter capacity	kW	0.1kW	0.25kW	0.55 kW	1.1 kW	1.5kW	2.2kW	4.0kW	5.5kW	7.5kW
n036	Motor rated current	A	0.6	1.1	1.9	3.3	6.2	8.5	19	19.6	26.6
n105	Torque compensation iron loss	W	1.7	3.4	4.2	6.5	11.1	11.8	19	28.8	43.9
n106	Motor rated slip	Hz	2.5	2.6	2.9	2.5	2.6	2.9	3.3	1.5	1.3
n107	Motor phase to neutral*	Ω	17.99	10.28	4.573	2.575	1.233	0.8	0.385	0.199	0.111
n108	Motor leak inductance	MH	110.4	56.08	42.21	19.07	13.4	9.81	6.34	4.22	2.65
n110	Motor no-load current	%	72	73	62	55	45	35	32	26	30

■ 200V class single-phase

No.	Name	Unit								
-	Inverter capacity	kW	0.1kW	0.25kW	0.55 kW	1.1 kW	1.5kW	2.2kW	-	4.0kW
n036	Motor rated current	A	0.6	1.1	1.9	3.3	6.2	8.5	-	19
n105	Torque compensation iron loss	W	1.7	3.4	4.2	6.5	11.1	11.8	-	19
n106	Motor rated slip	Hz	2.5	2.6	2.9	2.5	2.6	2.9	-	3.3
n107	Motor phase to neutral*	Ω	17.99	10.28	4.573	2.575	1.233	0.8	-	0.385
n108	Motor leak inductance	MH	110.4	56.08	42.21	19.07	13.4	9.81	-	6.34
n110	Motor no-load current	%	72	73	62	55	45	35	-	32

■ 400V class 3-phase

No.	Name	Unit									
-	Inverter capacity	kW	0.37kW	0.55 kW	1.1 kW	1.5kW	2.2kW	3.0kW	4.0kW	5.5kW	7.5kW
n036	Motor rated current	A	0.6	1.0	1.6	3.1	4.2	5.5	7.0	9.8	13.3
n105	Torque compensation iron loss	W	3.4	4.0	6.1	11.0	11.7	19.3	19.3	28.8	43.9
n106	Motor rated slip	Hz	2.5	2.7	2.6	2.5	3.0	3.2	3.2	1.5	1.3
n107	Motor phase to neutral*	Ω	41.97	19.08	11.22	5.044	3.244	1.514	1.514	0.797	0.443
n108	Motor leak inductance	MH	224.3	168.8	80.76	53.25	40.03	24.84	24.84	16.87	10.59
n110	Motor no-load current	%	73	63	52	45	35	33	33	26	30

* Values of motor phase to neutral are set to half of the standard value

9-2 Option Specifications

9-2-1 EMC-compatible Noise Filter

- Be sure to select an optimum Noise Filter from the following so that the Inverter will satisfy EMC directive requirements of the EC Directives.
- Connect the Noise Filter between the power supply and the input terminals (R/L1, S/L2, and T/L3) of the Inverter.
- The Inverter can be mounted to the upper side of the Noise Filter because the upper side of the Noise Filter incorporates mounting holes for the Inverter.

■ Standard Specifications

3-phase 200-VAC Noise Filter

Inverter	3-phase 200-VAC Noise Filter	
Model 3G3MV-	Model 3G3MV-	Rated current (A)
A2001/A2002/A2004/A2007	PFI2010-E	10
A2015/A2022	PFI2020-E	16 to 20
A2040	PFI2030-E	26 to 30
A2055/A2075	PFI2050-E	50

Single-phase 200-VAC Noise Filter

Inverter	Single-phase 200-V Noise Filter	
Model 3G3MV-	Model 3G3MV-	Rated current (A)
AB001/AB002/AB004	PFI1010-E	10
AB007/AB015	PFI1020-E	20
AB022	PFI1030-E	30
AB040	PFI1040-E	40

3-phase 400-VAC Noise Filter

Inverter	3-phase 400-VAC Noise Filter	
Model 3G3MV-	Model 3G3MV-	Rated current (A)
A4002/A4004	PFI3005-E	5
A4007/A4015/A4022	PFI3010-E	10
A4030/A4040	PFI3020-E	15 to 20
A4055/A4075	PFI3030-E	30

■ Connection Example

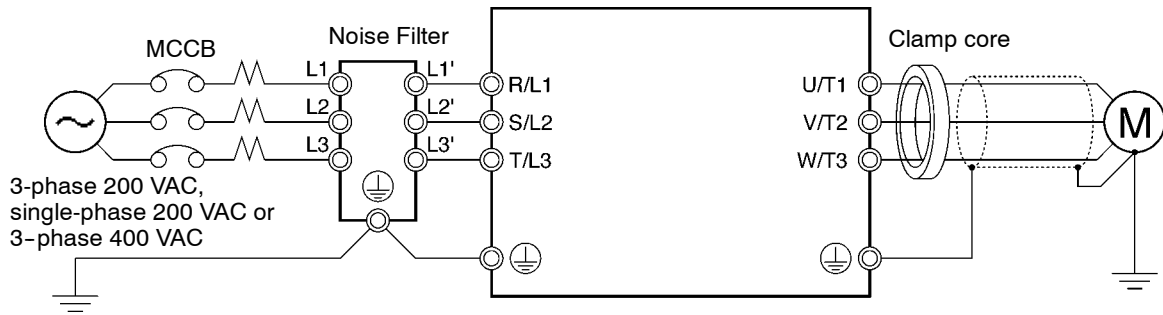

■ External Dimensions

Noise Filters for Single-phase 200-VAC Models

● 3G3MV-PFI1010-E

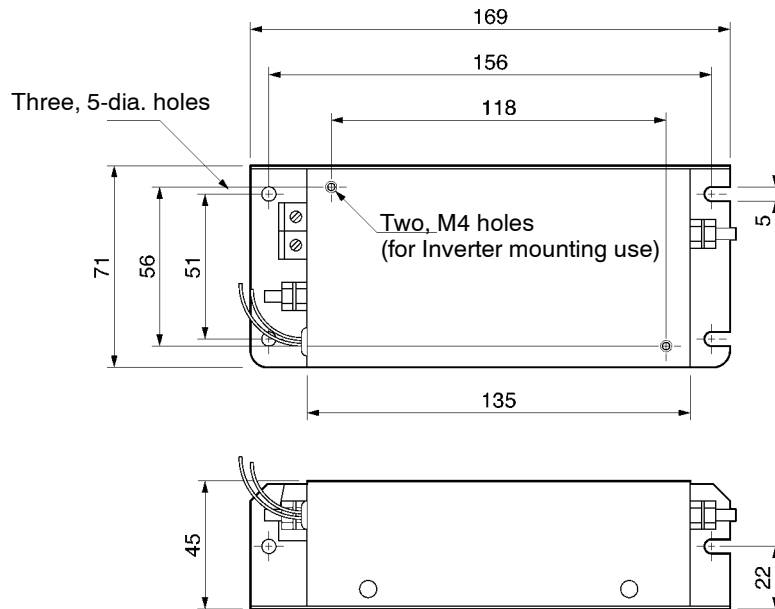

● 3G3MV-PFI1020-E

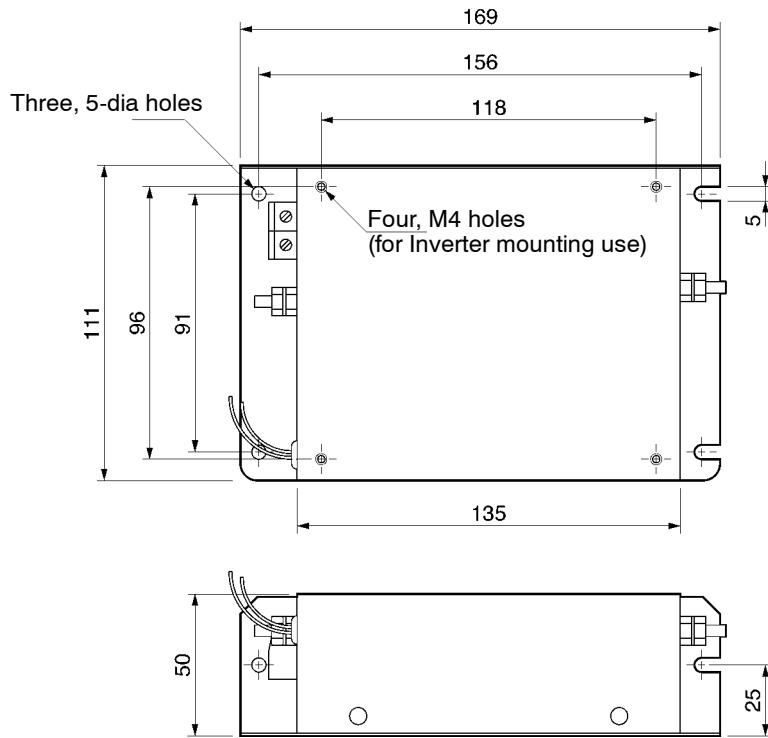

● 3G3MV-PFI1030-E

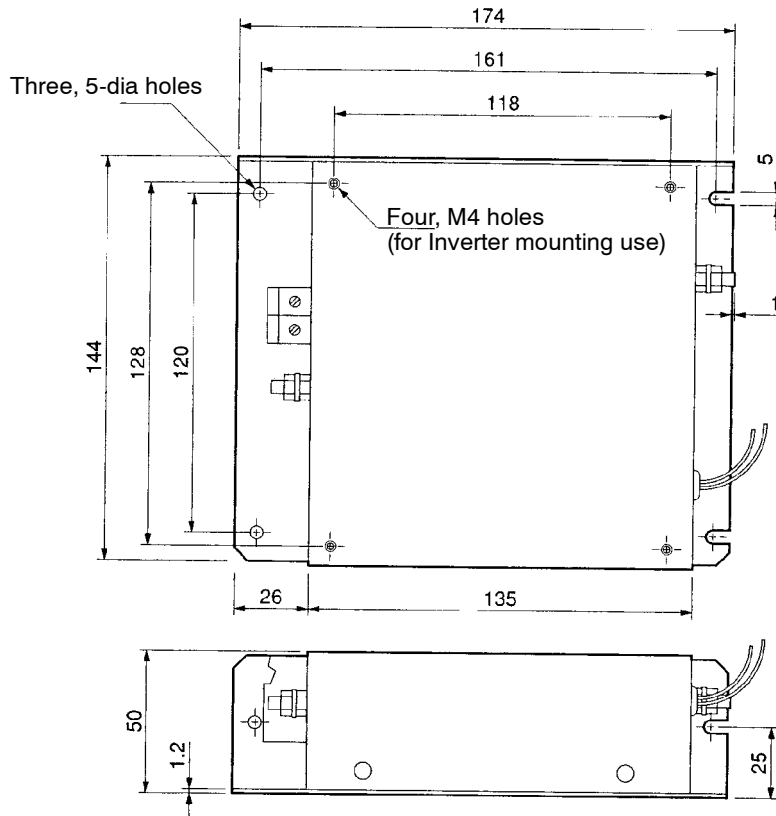

● 3G3MV-PFI1040-E

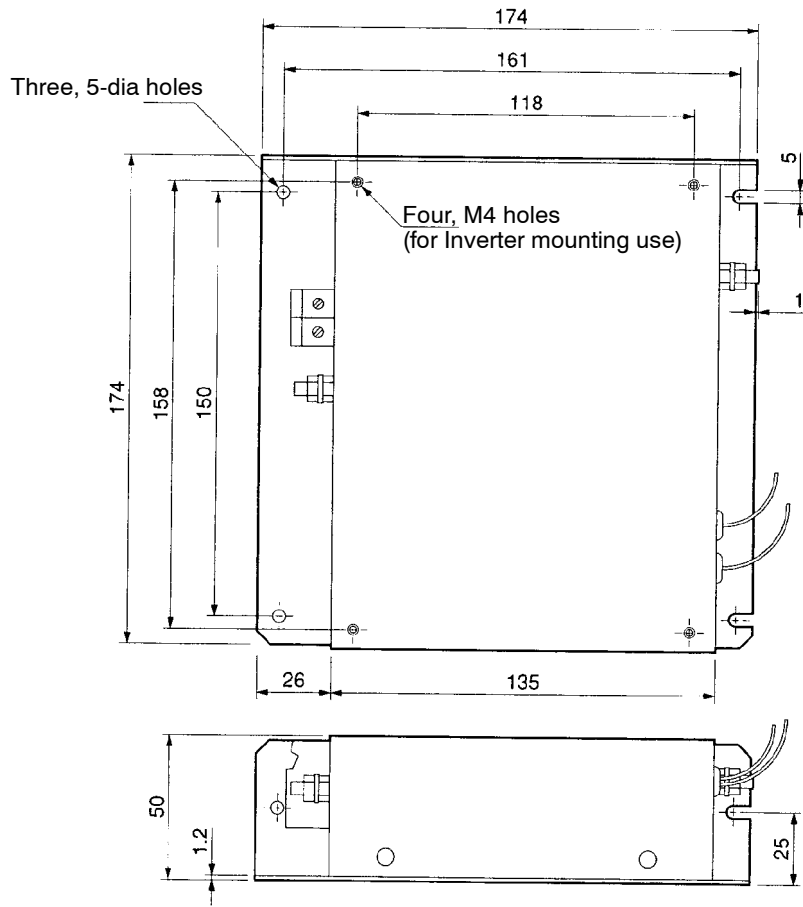

Noise Filters for 3-phase 200-VAC Inverter Models

● 3G3MV-PFI2010-E

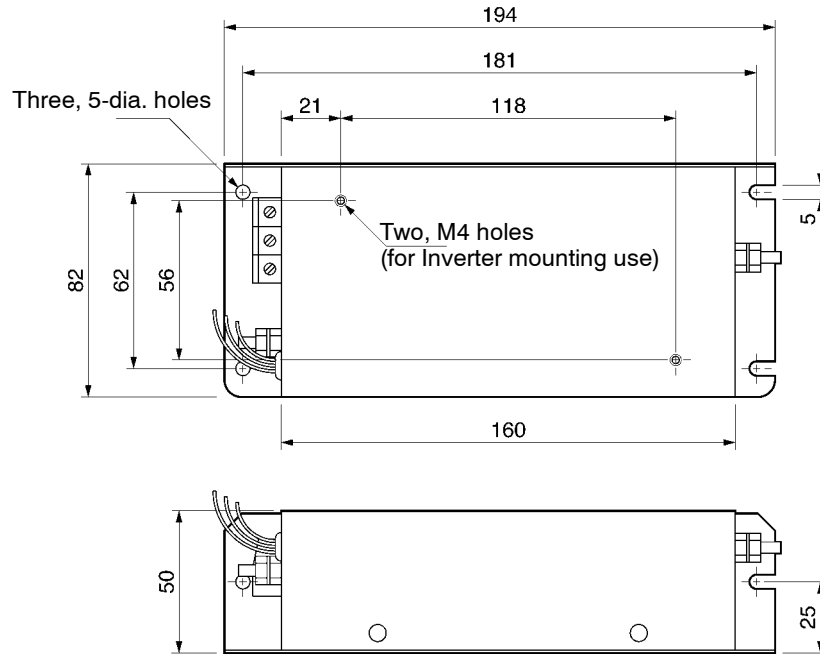

● 3G3MV-PFI2020-E

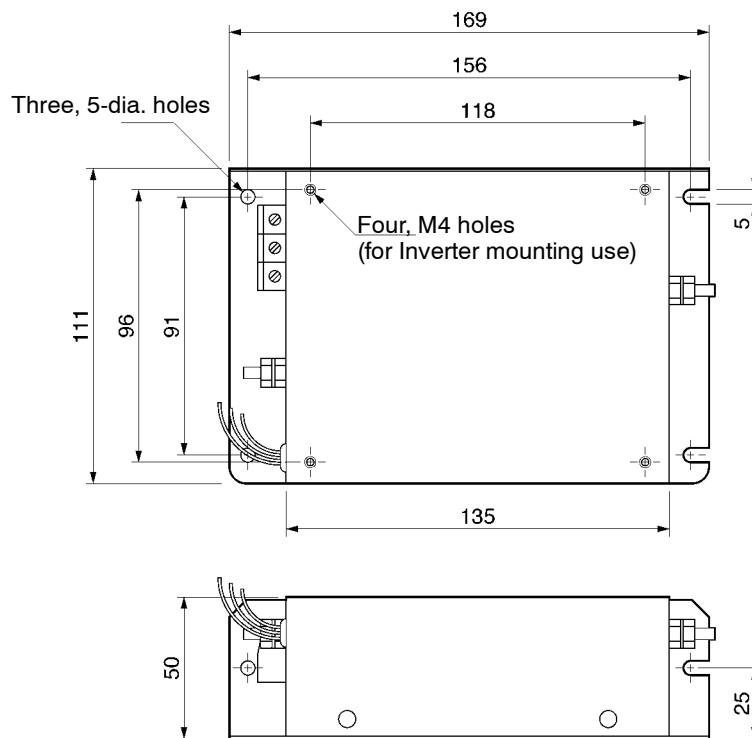

● 3G3MV-PFI2030-E

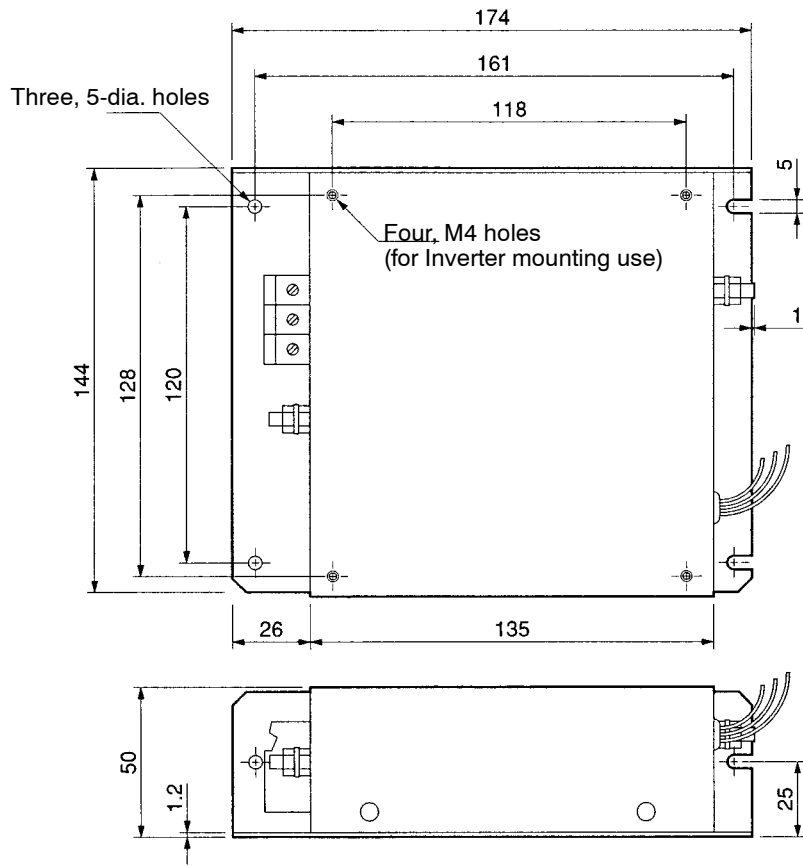

• 3G3MV-PFI2050-E

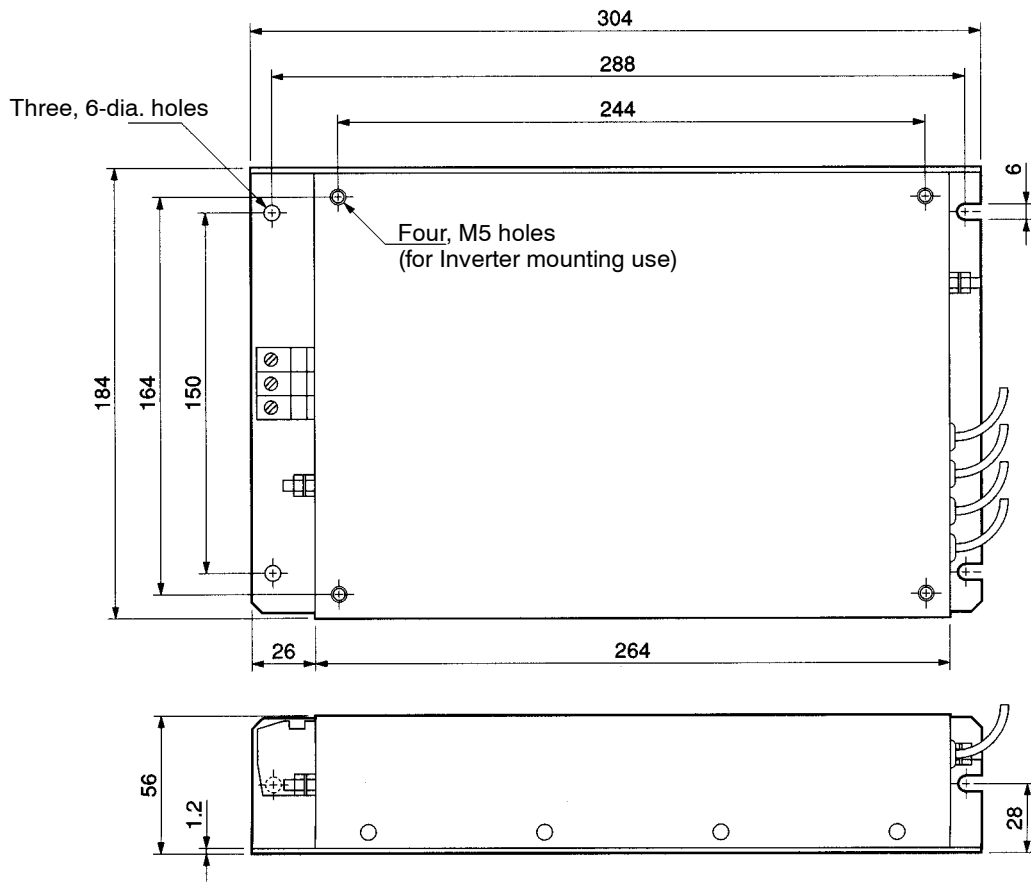

Noise Filters for 3-phase 400-VAC Models

● 3G3MV-PFI3005-E, 3G3MV-PFI3010-E

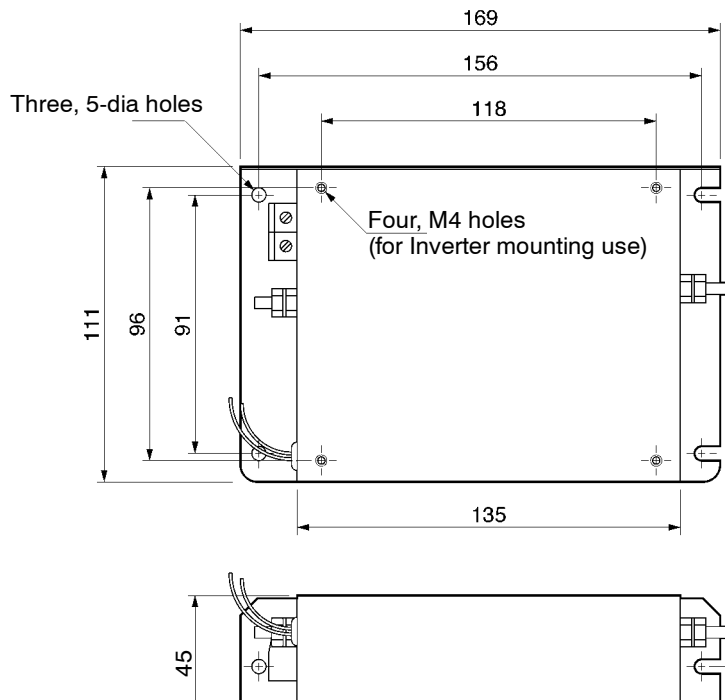

● 3G3MV-PFI3020-E

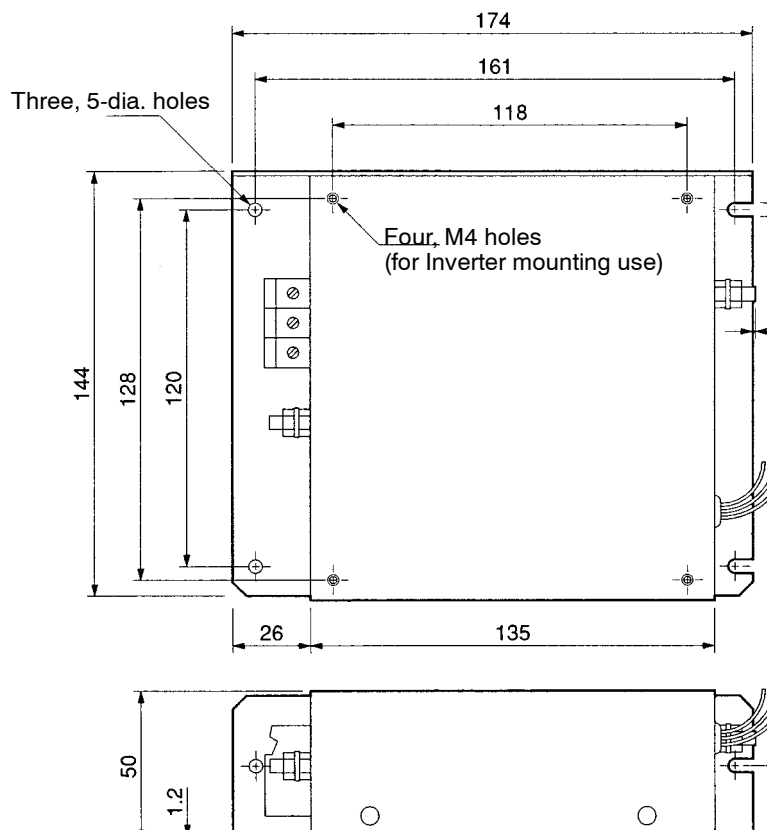

• 3G3MV-PRS3030V

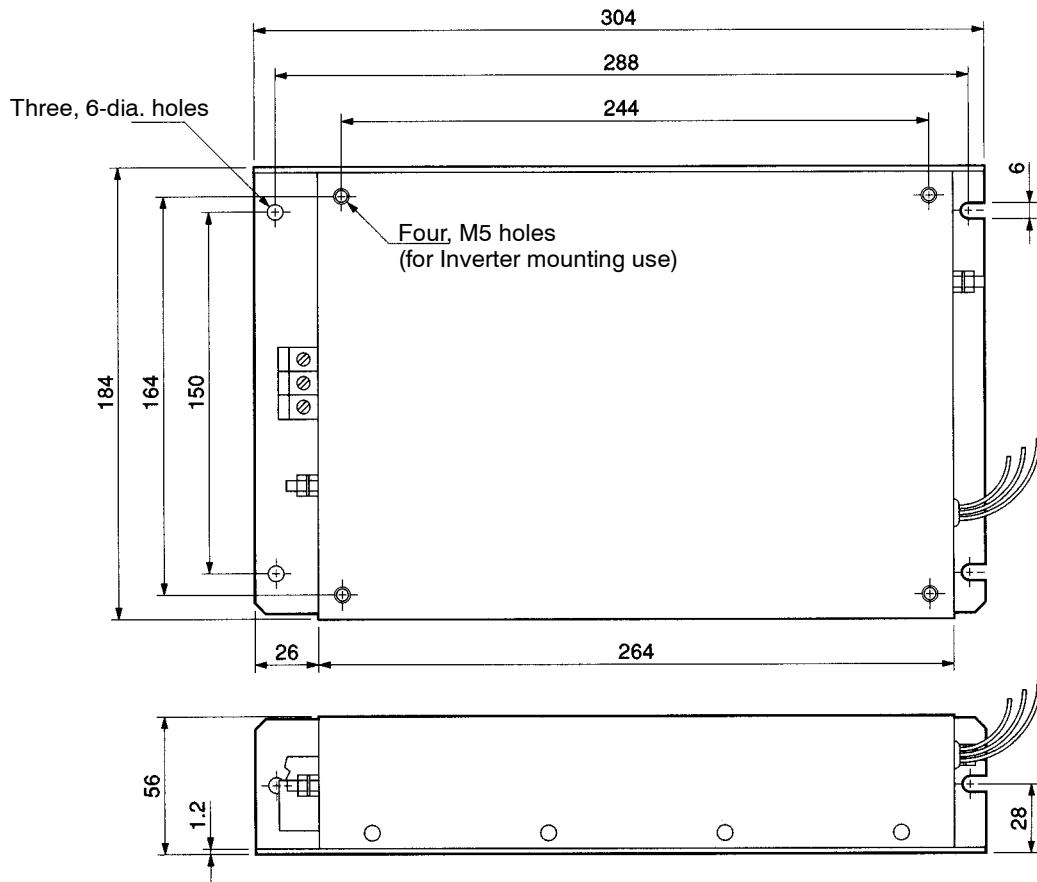

9-2-2 DIN Track Mounting Bracket

■ 3G3IV-PZZ08122□

An adapter making it possible to easily mount the Inverter to DIN tracks.

■ Applicable Models

Inverter		DIN Track Mounting Bracket
3-phase 200 V AC	3G3MV-A2001/-A2002/-A2004/-A2007	3G3IV-PZZ08122A
	3G3MV-A2015/-A2022	3G3IV-PZZ08122B
	3G3MV-A2040	3G3IV-PZZ08122C
Single-phase 200 V AC	3G3MV-AB001/-AB002/-AB004	3G3IV-PZZ08122A
	3G3MV-AB007/-AB015	3G3IV-PZZ08122B
	3G3MV-AB022	3G3IV-PZZ08122C
	3G3MV-AB040	3G3IV-PZZ08122D
3-phase 400 V AC	3G3MV-A4002/-A4004/-A4007/-A4015/-A4022	3G3IV-PZZ08122B
	3G3MV-A4030/A4040	3G3IV-PZZ08122C

External Dimensions (mm)

3G3IV-PZZ08122A

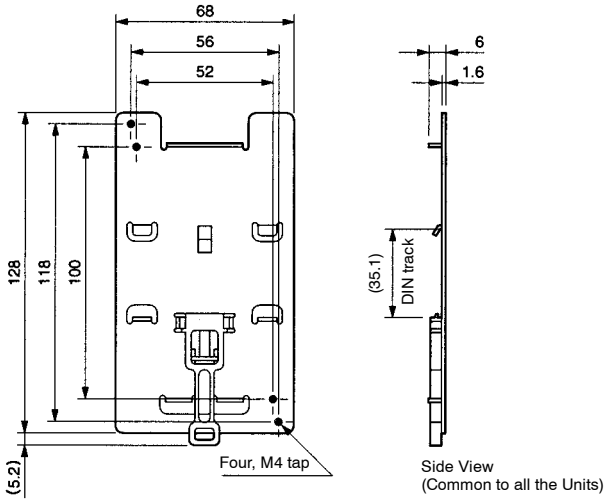

3G3IV-PZZ08122B

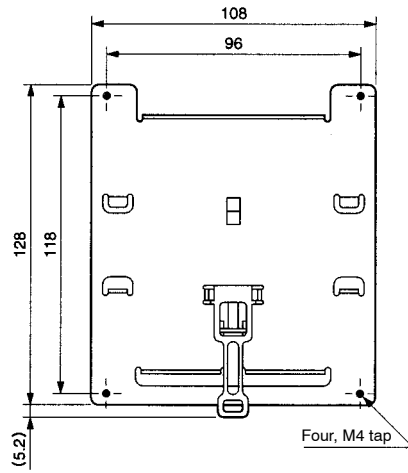

3G3IV-PZZ08122C

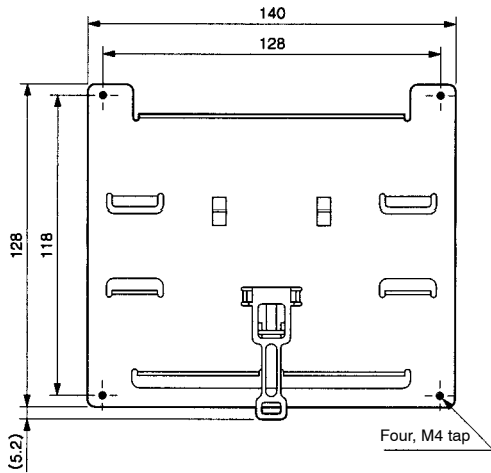

3G3IV-PZZ08122D

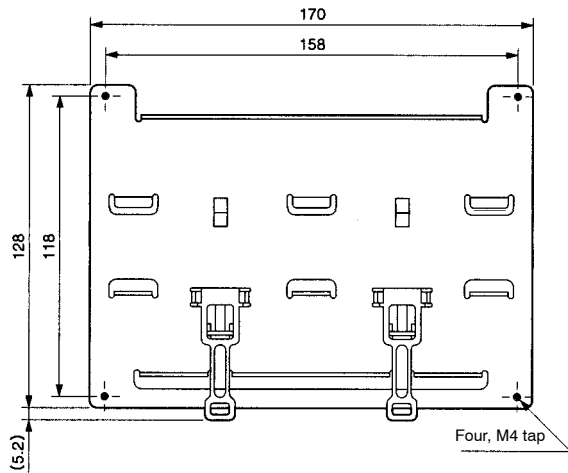

9-2-3 DC Reactor

■ 3G3HV-PUZDAB □

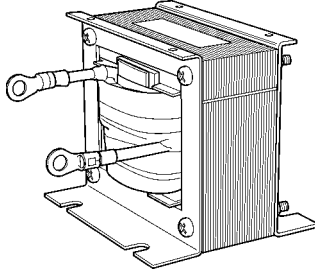

The DC Reactor suppresses harmonic current generated from the Inverter and improves the power factor of the Inverter. The DC Reactor suppresses harmonic current more effectively than the AC Reactor. Furthermore, the DC Reactor can be used in combination with the AC Reactor.

■ Applicable Models

Inverter		DC Reactor				
Voltage class	Max. applicable motor capacity (kW)	Model 3G3HV-	Rated voltage (V)	Rated current (A)	Inductance (mH)	Loss (W)
200 V	0.1 to 0.75	PUZDAB5.4A8MH	800 VDC	5.4	8	8
	1.5 to 4.0	PUZDAB18A3MH		18	3	18
	5.5 to 7.5	PUZDAB36A1MH		36	1	22
400 V	0.2 to 0.75	PUZDAB3.2A28MH	800 VDC	3.2	28	9
	1.5 to 2.2	PUZDAB5.7A11MH		5.7	11	11
	3.0 to 4.0	PUZDAB12A6.3MH		12	6.3	16
	5.5 to 7.5	PUZDAB23A3.6MH		23	3.6	27

■ External Dimensions (mm)

External Dimension 1

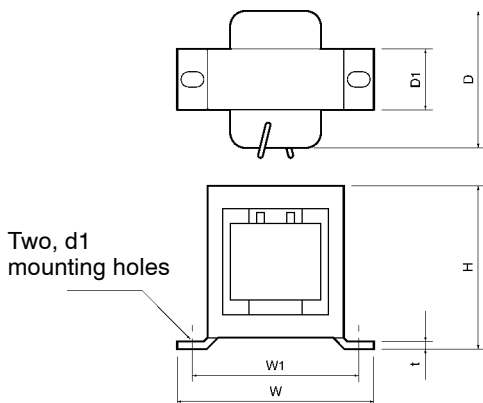

External Dimension 2

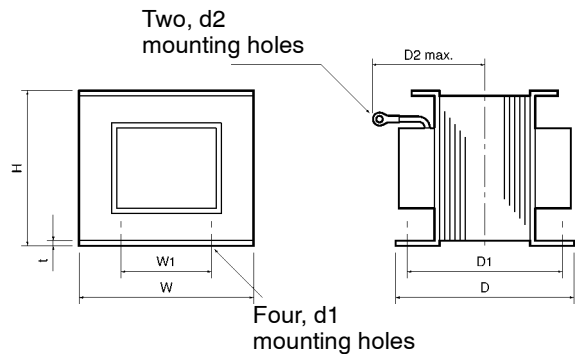

Model 3G3HV- PUZDAB□	External dimen- sion	Dimension (mm)									Weight (kg)
		H	W	W1	D	D1	D2	t	d1	d2	
5.4A8MH	1	53	85	74	60	32	---	0.8	M4	---	0.8
18A3MH	2	76	86	60	72	55	80	1.2	M4	M5	2.0
36A1MH	2	93	105	64	92	80	90	1.6	M6	M6	3.2
3.2A28MH	1	53	85	74	60	32	---	0.8	M4	---	0.8
5.7A11MH	1	60	90	80	60	32	---	0.8	M4	---	1.0
12A6.3MH	2	76	86	60	72	55	80	1.2	M4	M5	2.0
23A3.6MH	2	93	105	64	92	80	90	1.6	M6	M5	3.2

9-2-4 AC Reactor

■ 3G3IV-PUZBAB□

The AC Reactor suppresses harmonic current generated from the Inverter and improves the power factor of the Inverter. Connect the AC Reactor to the Inverter if the capacity of the power supply is much larger than that of the Inverter. Select the AC Reactor model from the following table according to the motor capacity.

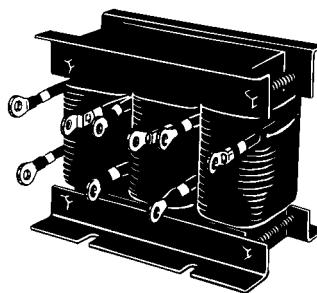

■ Connection Example

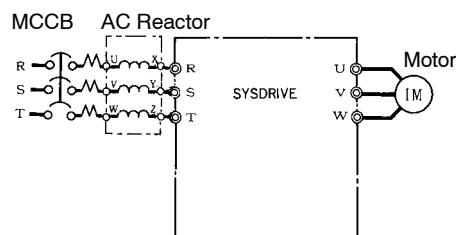

■ Applicable Range

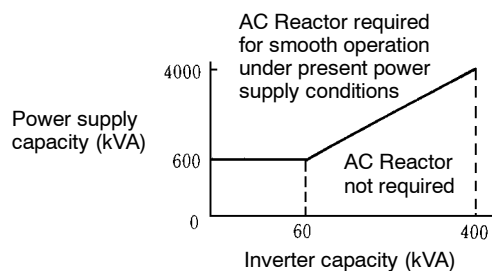

■ Applicable Models and Dimensions

● 200-V Class

Max. applicable motor capacity (kW)	Model 3G3IV-PUZBAB□	Current (A)	Inductance (mH)	Loss (W)	Weight (kg)
0.1 to 0.2	2A7.0MH	2	7.0	8	2.5
0.4	2.5A4.2MH	2.5	4.2	15	2.5
0.75	5A2.1MH	5	2.1	15	2.5
1.5	10A1.1MH	10	1.1	25	3
2.2	15A0.71MH	15	0.71	30	3
4.0	20A0.53MH	20	0.53	35	3
5.5	30A0.35MH	30	0.35	45	3
7.5	40A0.265MH	40	0.265	50	4

Model 3G3IV-PUZBAB□	Dimension (mm)											
	A	B	B1	C	D	E	F	H	J	K	L	M
2A7.0MH	120	71	---	115	40	50	105	20	M6	10.5	7	M4
2.5A4.2MH	120	71	---	120	40	50	105	20	M6	10.5	7	M4
5A2.1MH	120	71	---	120	40	50	105	20	M6	10.5	7	M4
10A1.1MH	130	88	---	130	50	65	130	22	M6	11.5	7	M4
15A0.71MH	130	88	---	130	50	65	130	22	M6	11.5	7	M4
20A0.53MH	130	88	114	105	50	65	130	22	M6	11.5	7	M5
30A0.35MH	130	88	119	105	50	70	130	22	M6	9	7	M5
40A0.265MH	130	98	139	105	50	75	130	22	M6	11.5	7	M6

● 400-V Class

Max. applicable motor capacity (kW)	Model 3G3IV-PUZBAB□	Current (A)	Inductance (mH)	Loss (W)	Weight (kg)
0.2 to 0.4	1.3A18.0MH	1.3	18.0	15	2.5
0.75	2.5A8.4MH	2.5	8.4	15	2.5
1.5	5A4.2MH	5	4.2	25	3
2.2	7.5A3.6MH	7.5	3.6	35	3
3.0 to 4.0	10A2.2MH	10	2.2	43	3
5.5	15A1.42MH	15	1.42	50	4
7.5	20A1.06MH	20	1.06	50	5

Model 3G3IV-PUZBAB□	Dimension (mm)											
	A	B	B1	C	D	E	F	H	J	K	L	M
1.3A18.0MH	120	71	---	120	40	50	105	20	M6	10.5	7	M4
2.5A8.4MH	120	71	---	120	40	50	105	20	M6	10.5	7	M4
5A4.2MH	130	88	---	130	50	70	130	22	M6	9	7	M4
7.5A3.6MH	130	88	---	130	50	70	130	22	M6	9	7	M4
10A2.2MH	130	88	---	130	50	65	130	22	M6	11.5	7	M4
15A1.42MH	130	98	---	130	50	75	130	22	M6	11.5	7	M4
20A1.06MH	160	90	115	130	75	70	160	25	M6	10	7	M5

Dimensions

All models except: 3G3IV-PUZBAB20A0.53MH
 3G3IV-PUZBAB30A0.53MH
 3G3IV-PUZBAB40A0.265MH
 3G3IV-PUZBAB20A1.06MH

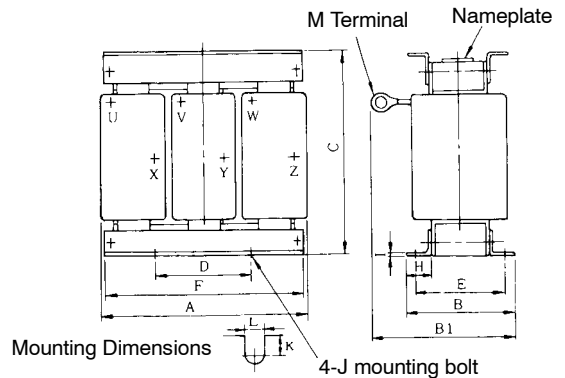
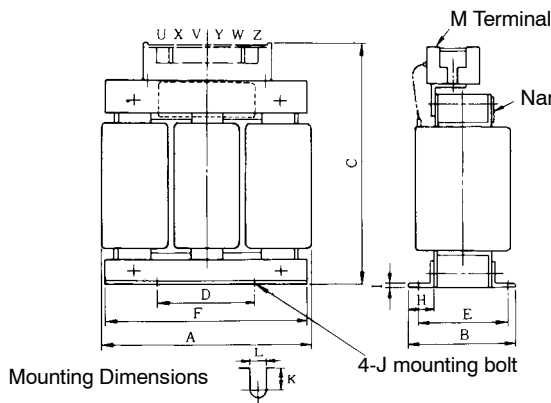

9-2-5 Output Noise Filter

■ 3G3IV-PLF□ (Tokin)

The Output Noise Filter suppresses the generated noise of the Inverter from being transmitted to the output line. Connect the Output Noise Filter to the output side of the Inverter.

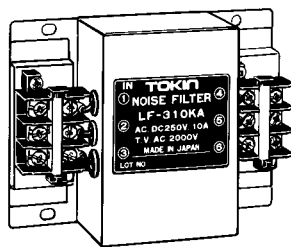

■ Connection Example

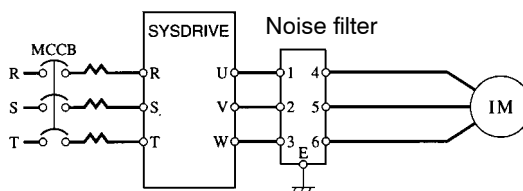

■ Application Models

Inverter			Output Noise Filter	
Voltage class	Max. applicable motor capacity (kW)	Inverter capacity (kVA)	Model	Rated current (A)
200-V class	0.1	0.3	3G3IV-PLF310KA	10
	0.2	0.6		
	0.4	1.4		
	0.75	2.1		
	1.5	2.7		
	2.2	4.1		
	3.7	6.9		
400-V class	0.2	0.9	3G3IV-PLF310KB	10
	0.4	1.4		
	0.75	2.1		
	1.5	2.7		
	2.2	4.1		
	4.0	6.9		

■ Dimensions

External Dimensions

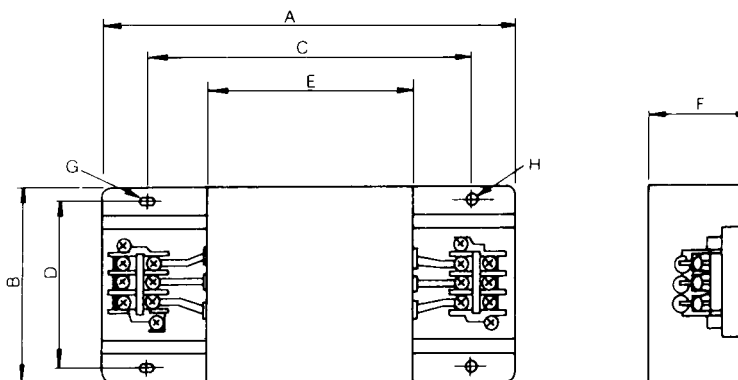

Model 3G3IV-	Dimension (mm)									Weight (kg)
	Terminal board	A	B	C	D	E	F	G	H	
PLF310KA	TE-K5.5 M4	140	100	100	90	70	45	7 × 4.5 dia.	4.5 dia.	0.5
PLF320KA										0.6
PLF310KB										0.5

9-2-6 CompoBus/D Communications Unit

■ 3G3MV-PDRT1-SINV

This Unit is required when controlling the Inverter from CompoBus/D. Remote I/O functions and message functions can be used to suit the application.

Note Only CompoBus/D Communications Units manufactured after January 1st, 2000 can be connected to 5.5-kW and 7.5-kW Inverters. Earlier products are not compatible with these Inverters.

■ External Dimensions (mm)

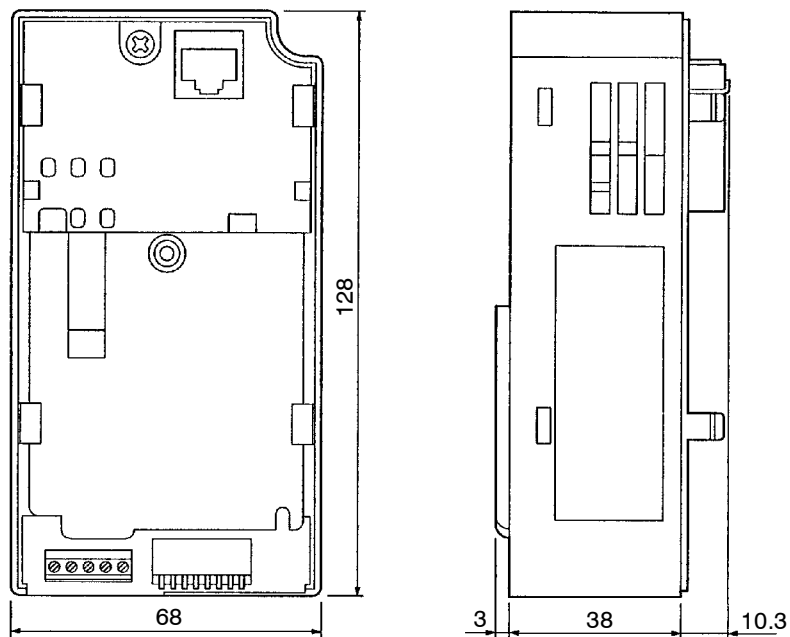

■ Connection Example

C200HW-DRM21-V1 or CVM1-DRM21-V1 Master Unit

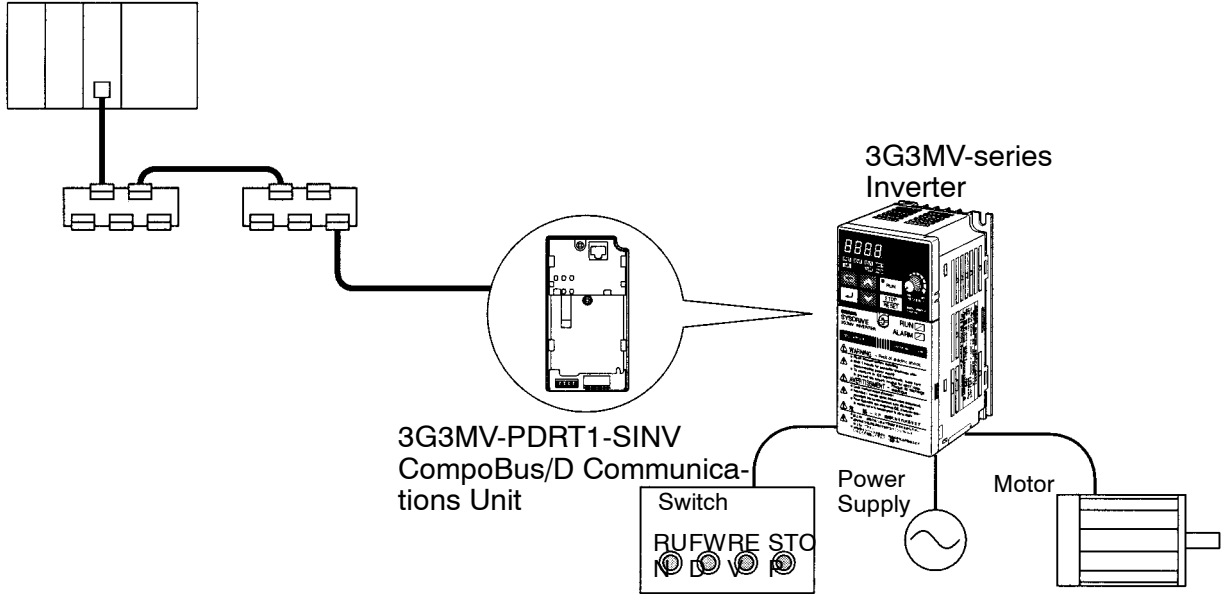

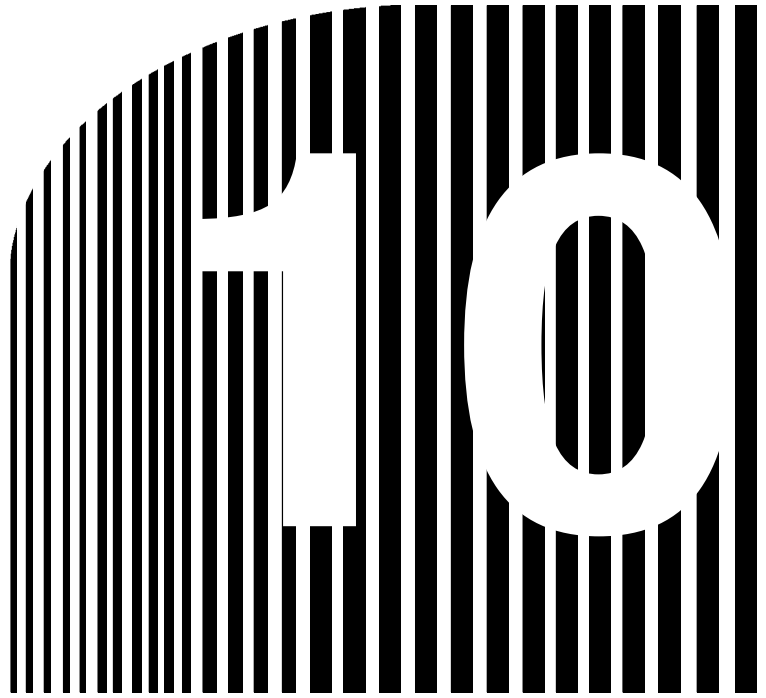

Chapter 10

• List of Parameters •

■ Function Group 1 (n001 through n049)

Parameter No.	Register No.	Name	Description	Setting range	Unit of setting	Default setting	Changes during operation	Reference page
n001	0101	Parameter write-prohibit selection/parameter initialization	<p>Used to prohibit parameters to be written, sets parameters, or change the monitor range of parameters.</p> <p>Used to initialize parameters to default settings.</p> <p>0: Parameter n001 is set or displayed. Parameters from n002 to n079 can be displayed only.</p> <p>1: Parameters from n001 to n049 (function group 1) are set or displayed.</p> <p>2: Parameters from n001 to n079 (function groups 1 and 2) are set or displayed.</p> <p>3: Parameters from n001 to n119 (function groups 1 through 3) are set or displayed.</p> <p>4: Parameters from n001 to n179 (function groups 1 through 4) are set or displayed.</p> <p>5: Same as set to 4, but run command excepted in program mode.</p> <p>6: Clears the error log.</p> <p>8: Initializes parameters to default settings in 2-wire sequence.</p> <p>9: Initializes parameters to default settings in 3-wire sequence.</p> <p>10: For the USA, initializes parameter in 2-wire sequence.</p> <p>11: For the USA, Initializes parameters in 3-wire sequence.</p>	0 to 11	1	1	No	3-13 5-2

Parameter No.	Register No.	Name	Description	Setting range	Unit of setting	Default setting	Changes during operation	Reference page
n002	0102	Control mode selection	<p>Used to select the control mode of the Inverter.</p> <p>0: V/f control mode 1: Vector control mode (open loop)</p> <p>Note The set value in n002 is not initialized with n001 set to 8 or 9.</p> <p>Note Each of the following parameters is initialized according to the preset control mode. The default setting varies with the control mode.</p> <p>n014: Middle output frequency n015: Middle output frequency voltage n016: Minimum output frequency n017: Minimum output frequency voltage n104: Torque compensation primary delay time constant n111: Slip compensation gain n112: Slip compensation primary delay time constant</p> <p>See the reference pages for details.</p>	0, 1	1	0	No	5-3
n003	0103	Operation command selection	<p>Used to select the input method for the RUN and STOP commands in remote mode.</p> <p>0: The STOP/RESET Key on the digital Operator is enabled. 1: Multi-function input is enabled through the control circuit terminals in 2- or 3-wire sequence. 2: RS-422/485 communications are enabled. 3: Input is enabled from the optional CompoBus/D Communications Unit.</p> <p>Note The RUN command only through key sequences on the Digital Operator is acceptable in local mode.</p>	0 to 3	1	0	No	5-11

Parameter No.	Register No.	Name	Description	Setting range	Unit of setting	Default setting	Changes during operation	Reference page
n004	0104	Frequency reference selection	Used to set the input method for the frequency reference in remote mode. 0: Digital Operator 1: Frequency reference 1 (n024) 2: Frequency reference control terminal (0 to 10 V) 3: Frequency reference control terminal (4 to 20 mA) 4: Frequency reference control terminal (0 to 20 mA) 5: Pulse train reference control terminal is enabled. 6: Frequency reference input through RS44/RS485 is enabled. 7: Multi-function analog voltage input (0 to 10 V) is enabled. 8: Multi-function analog current input (4 to 20 mA) is enabled. 9: Frequency reference input through CompoBus/D communications is enabled.	0 to 9	1	0	No	5-12
n005	0105	Stopping method selection	Used to set the stopping method for use when the STOP command is input. 0: Decelerates to stop in preset time. 1: Coasts to stop (with output turned OFF by the STOP command)	0, 1	1	0	No	5-31
n006	0106	Reverse rotation-prohibit selection	Used to select the operation with the reverse command input. 0: Reverse enabled (accept). 1: Reverse disabled (not accept).	0, 1	1	0	No	5-30
n007	0106	STOP Key function selection	Used to enable/disable the STOP Key in remote mode with n003 for operation mode selection not set to 0. 0: STOP Key of the Digital Operator enabled. 1: STOP Key of the Digital Operator disabled.	0, 1	1	0	No	5-11
n008	0108	Frequency reference selection in local mode	Used to set the input method for the frequency reference in local mode. 0: The FREQ adjuster of the Digital Operator enabled. 1: Key sequences on the Digital Operator enabled. (Set in n024.)	0, 1	1	0	No	5-13
n009	0109	Operator frequency setting method selection	Used to enable the Enter Key for setting the frequency reference with the Increment and Decrement Keys. 0: The value is entered with the Enter Key pressed. 1: The value is enabled when the value is input.	0, 1	1	0	No	5-24

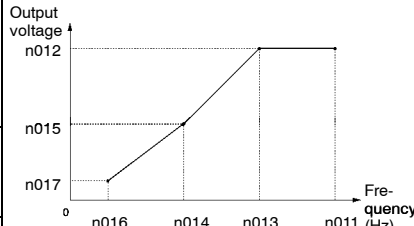
Parameter No.	Register No.	Name	Description	Setting range	Unit of setting	Default setting	Changes during operation	Reference page	
n010	010A	Operation selection at Digital Operator interruption	Select whether or not to detect the OPR error (Digital Operator connection error). 0: No (The Inverter continues operating.) 1: Yes (Error output turns ON and the Inverter coasts to a stop)	0, 1	1	0	No	6-41	
n011	010B	Maximum frequency (FMAX)	Used to set the V/f pattern as the basic characteristic of the Inverter. V/f control mode: set output voltage per frequency Vector control mode: set for torque adjustment	50.0 to 400.0	0.1 Hz	60.0	No	5-7	
n012	010C	Maximum voltage (VMAX)	 <p>The graph shows a linear increase in output voltage from parameter n017 at frequency 0 to parameter n013 at frequency n011. The voltage then remains constant at n013 up to frequency n011. Parameters n016 and n014 are marked on the frequency axis between n017 and n013.</p>	0.1 to 255.0 (0.1 to 510.0)	0.1 V	200.0 (400.0) (see note 1)	No	5-7	
n013	010D	Maximum voltage frequency (FA)		0.2 to 400.0	0.1 Hz	60.0	No	5-7	
n014	010E	Middle output frequency (FB)		<p>Note Set the parameters so that the following condition will be satisfied. n016 \square n014 < n013 \square n011</p> <p>Note The value set in n015 will be ignored if parameters n016 and n014 have the same value.</p>	0.1 to 399.9	0.1 Hz	1.5	No	5-7
n015	010F	Middle output frequency voltage (VC)			0.1 to 255.0 (0.1 to 510.0)	0.1 V	12.0 (24.0) (see note 2)	No	5-7
n016	0110	Minimum output frequency (FMIN)		0.1 to 10.0	0.1 Hz	1.5	No	5-7	
n017	0111	Minimum output frequency voltage (VMIN)		0.1 to 50.0 (0.1 to 100.0)	0.1 V	12.0 (24.0) (see note 2)	No	5-7	
n018	0112	Acceleration/Deceleration time setting (n018)		Select the acceleration or deceleration time of the Inverter. 0: 0.1 s (Less than 1,000 s: 0.1-s increments; 1,000 s or over: 1-s increments) 1: 0.01 s (Less than 100 s: 0.01-s increments; 100 s or over: 0.1-s increments)	0, 1	1	0	No	5-27

Note 1. The values in brackets are those for 400-V-class Inverters.

Note 2. The values in brackets are those for 400-V-class Inverters.

Parameter No.	Register No.	Name	Description	Setting range	Unit of setting	Default setting	Changes during operation	Reference page
n019	0113	Acceleration time 1	Acceleration time: The time required to go from 0% to 100% of the maximum frequency.	0.0 to 6,000	0.1 s (change in n018)	10.0	Yes	5-27
n020	0114	Deceleration time 1	Deceleration time: The time required to go from 100% to 0% of the maximum frequency. Note The actual acceleration or deceleration time is obtained from the following formula. Acceleration/Deceleration time = (Acceleration/Deceleration time set value) × (Frequency reference value) ÷ (Max. frequency)			10.0	Yes	5-27
n021	0115	Acceleration time 2				10.0	Yes	5-27
n022	0116	Deceleration time 2				10.0	Yes	5-27
n023	0117	S-shape acceleration/deceleration characteristic	Used to set S-shape acceleration/deceleration characteristics. 0: No S-shape acceleration/deceleration (trapezoidal acceleration/deceleration) 1: S-shape acceleration/deceleration characteristic time 0.2 s 2: S-shape acceleration/deceleration characteristic time 0.5 s 3: S-shape acceleration/deceleration characteristic time 1.0 s Note When the S-shape acceleration/deceleration characteristic time is set, the acceleration and deceleration times will be lengthened according to the S-shape at the beginning and end of acceleration/deceleration.	0 to 3	1	0	No	5-28

Parameter No.	Register No.	Name	Description	Setting range	Unit of setting	Default setting	Changes during operation	Reference page		
n024	0118	Frequency reference 1	Used to set internal frequency references.	0.0 to max. frequency	0.01 Hz (change in n035)	6.00	Yes	5-20		
n025	0119	Frequency reference 2	Note Frequency reference 1 is enabled in remote mode with n004 for frequency reference selection set to 1.			0.00	Yes	5-20		
n026	011A	Frequency reference 3	Note These frequency references are selected with multi-step speed references (multi-function input). See the reference pages for the relationship between multi-step speed references and frequency references.			0.00	Yes	5-20		
n027	011B	Frequency reference 4				0.00	Yes	5-20		
n028	011C	Frequency reference 5				0.00	Yes	5-20		
n029	011D	Frequency reference 6				0.00	Yes	5-20		
n030	011E	Frequency reference 7				0.00	Yes	5-20		
n031	011F	Frequency reference 8				0.00	Yes	5-20		
n032	0120	Inching frequency command	Used to set the inching frequency command. Note The inching frequency command is selected with the inching command (multi-function input). The inching frequency command takes precedence over the multi-step speed reference.					6.00	Yes	5-23
n033	0121	Upper frequency reference limit	Used to set the upper and lower frequency reference limits in percentage based on the maximum frequency as 100%. Note If n034 is set to a value less than the minimum output frequency (n14), the Inverter will have no output when a frequency reference less than the minimum output frequency input is input.			0 to 110	1%	100	No	5-13
n034	0122	Lower frequency reference limit		0 to 110	1%	0	No	5-13		

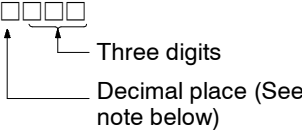
Parameter No.	Register No.	Name	Description	Setting range	Unit of setting	Default setting	Changes during operation	Reference page
n035	0123	Frequency reference setting/decimal place selection	<p>Set the unit of frequency reference and frequency-related values to be set or monitored through the Digital Operator.</p> <p>0: 0.01 Hz 1: 0.1% 2 to 39: rpm (number of motor poles) 40 to 39,899: The value to be set or monitored at max. frequency. Set the value as shown below.</p>  <p>Note To display 50.0, for example, set the value to 1500. The setting unit of each parameter or monitor item below varies with the decimal place.</p> <ul style="list-style-type: none"> Parameters: n024 through n032 and n120 through n127 Monitor Items: U-01 and U-02 	0 to 3,999	1	0	No	5-19
n036	0124	Rated motor current	<p>Used to set the rated motor current for motor overload detection (OL1) based on the rated motor current.</p> <p>Note In vector control mode, this parameter is used as a constant for vector control operation.</p> <p>Note Motor overload detection (OL1) is disabled by setting the parameter to 0.0.</p> <p>Note The rated motor current is default to the standard rated current of the maximum applicable motor.</p>	0.0 to 150% of rated output current of the Inverter	0.1 A	Varies with the capacity	No	5-5 5-7
n037	0125	Motor protection characteristics	<p>Used to set the motor overload detection (OL1) for the electronic thermal characteristics of the motor.</p> <p>0: Protection characteristics for general-purpose induction motors 1: Protection characteristics for inverter-dedicated motors 2: No protection</p> <p>Note If a single Inverter is connected to more than one motor, set the parameter to 2 for no protection. The parameter is also disabled by setting n036 for rated motor to 0.0.</p>	0 to 2	1	0	No	6-41

Parameter No.	Register No.	Name	Description	Setting range	Unit of setting	Default setting	Changes during operation	Reference page
n038	0126	Motor protective time	<p>Used to set the electric thermal characteristics of the motor to be connected in 1-minute increments.</p> <p>Note The default setting does not require any changes in normal operation.</p> <p>Note To set the parameter according to the characteristics of the motor, check with the motor manufacturer the thermal time constant and set the parameter with some margin. In other words, set the value slightly shorter than the thermal time constant.</p> <p>Note To detect motor overloading quicker, reduce the set value, provided that it does not cause any application problems.</p>	1 to 60	1 min	8	No	6-41
n039	0127	Cooling fan operation	<p>Used to operate the Cooling Fan of the Inverter while the Inverter is turned ON or only while the Inverter is in operation.</p> <p>0: Rotates only while RUN command is input and for 1 minute after Inverter stops operating</p> <p>1: Rotates while Inverter is turned ON</p> <p>Note This parameter is available only if the Inverter incorporates a Cooling Fan.</p> <p>Note If the operation frequency of the Inverter is low, the life of the fan can be prolonged by setting the parameter to 0.</p>	0, 1	1	0	No	6-42
n040	0128	Direction for motor rotation	<p>0: CCW 1: CW</p> <p>The motor output shaft rotates in the counterclockwise ('0') or in the clockwise ('1') direction with a forward inverter reference.</p> <p>Note Applicable for software version No. 010024 or later.</p>	0, 1	1	0		

Parameter No.	Register No.	Name	Description	Setting range	Unit of setting	Default setting	Changes during operation	Reference page												
n041	0129	Acceleration time 3	4 acceleration/deceleration times can be set if Multi-func. Inputs (two from n050 to n056) are set to "11" (Accel/decel time select 1) and to "27" (Accel/decel time select 2). The following table shows which acceleration and deceleration times are selected by each possible combination of Accel/decel time select 1 and 2. The accel. and decel. times can be changed while the inverter is operating.	0.00 to 6000 sec	Depend on n018 setting	10.0 sec														
n042	012A	Deceleration time 3		0.00 to 6000 sec	Depend on n018 setting	10.0 sec														
			<table border="1"> <thead> <tr> <th>Accel/decel time select 1</th> <th>Accel/decel time select 2</th> <th>Acceleration time</th> <th>Deceleration time</th> </tr> </thead> <tbody> <tr> <td>OFF or not set</td> <td>OFF or not set</td> <td>Acceleration time 1 n019</td> <td>Deceleration time 1 n020</td> </tr> <tr> <td>ON</td> <td>OFF or not set</td> <td>Acceleration time 2 n021</td> <td>Deceleration time 2 n022</td> </tr> </tbody> </table>	Accel/decel time select 1	Accel/decel time select 2	Acceleration time	Deceleration time	OFF or not set	OFF or not set	Acceleration time 1 n019	Deceleration time 1 n020	ON	OFF or not set	Acceleration time 2 n021	Deceleration time 2 n022					
Accel/decel time select 1	Accel/decel time select 2	Acceleration time	Deceleration time																	
OFF or not set	OFF or not set	Acceleration time 1 n019	Deceleration time 1 n020																	
ON	OFF or not set	Acceleration time 2 n021	Deceleration time 2 n022																	
n043	012B	Acceleration time 4		0.00 to 6000 sec	Depend on n018 setting	10.0 sec														
n044	012C	Deceleration time 4		0.00 to 6000 sec	Depend on n018 setting	10.0 sec														
			<table border="1"> <thead> <tr> <th>OFF or not set</th> <th>ON</th> <th>Acceleration time 3 n041</th> <th>Deceleration time 3 n042</th> </tr> <tr> <th>ON</th> <th>ON</th> <th>Acceleration time 4 n043</th> <th>Deceleration time 4 n044</th> </tr> </thead> <tbody> <tr> <td colspan="4">Note Applicable for software version No. 010024 or later</td> </tr> </tbody> </table>	OFF or not set	ON	Acceleration time 3 n041	Deceleration time 3 n042	ON	ON	Acceleration time 4 n043	Deceleration time 4 n044	Note Applicable for software version No. 010024 or later								
OFF or not set	ON	Acceleration time 3 n041	Deceleration time 3 n042																	
ON	ON	Acceleration time 4 n043	Deceleration time 4 n044																	
Note Applicable for software version No. 010024 or later																				
n045 to n049	---	Not used	---	---	---	---	---	---												

■ Function Group 2 (n050 through n079)

Parameter No.	Register No.	Name	Description			Setting range	Unit of setting	Default setting	Changes during operation	Reference page
n050	0132	Multi-function input 1 (Input terminal S1)	Used to select the functions of multi-function input terminals S1 through S7.			1 to 25 (26 see note)	1	1	No	5-32
			Set value	Function	Description					
n051	0133	Multi-function input 2 (Input terminal S2)	0	Forward/Reverse rotation command	3-wire sequence (to be set in n052 only) By setting to 0, the set values in n050 and n051 are ignored and the following settings are forcibly made. S1: RUN input (RUN when ON) S2: STOP input (STOP when OFF) S3: Forward/Reverse rotation command (OFF: Forward; ON: Reverse)	1 to 25 (26 see note)	1	2	No	5-32
n052	0134	Multi-function input 3 (Input terminal S3)				0 to 25 (26 see note)	1	3	No	5-32
n053	0135	Multi-function input 4 (Input terminal S4)	1	Forward/Stop	Forward rotation command in 2-wire sequence. (Forward rotation with the signal turned ON)	1 to 25 (26 see note)	1	5	No	5-32
n054	0136	Multi-function input 5 (Input terminal S5)	2	Reverse/Stop	Reverse rotation command in 2-wire sequence (Reversed with the terminal turned ON)	1 to 25 (26 see note)	1	6	No	5-32
n055	0137	Multi-function input 6 (Input terminal S6)	3	External fault (NO)	ON: External fault (EF□ detection: □ is a terminal number)	1 to 25 (26 see note)	1	7	No	5-32
			4	External fault (NC)	OFF: External fault (EF□ detection: □ is a terminal number)					
n056	0138	Multi-function input 7 (Input terminal S7)	5	Fault reset	ON: Fault reset (disabled while RUN command is input)	1 to 25, (26 see note) 34, 35	1	10	No	5-32

Note Inverter overheating warning (setting value: 26) can be set for 5.5kW and 7.5kW Inverters only.

			6	Multi-step speed reference 1	Signals to select frequency references 1 through 16. Refer to <i>5-6-4 Setting Frequency References through Key Sequences</i> for the relationship between multi-step speed references and frequency references.					
			7	Multi-step speed reference 2						
			8	Multi-step speed reference 3						
			9	Multi-step speed reference 4						
			10	Inching frequency command	ON: Inching frequency command (taking precedence over the multi-step speed reference)					
			11	Acceleration/Deceleration time changeover	ON: Acceleration time 2 and deceleration time 2 are selected.					
			12	External base block command (NO)	ON: Output turned OFF					
			13	External base block command (NC)	OFF: Output turned OFF					
			14	Search command (Searching starts from maximum frequency)	ON: Speed search (Searching starts from n09)					
			15	Search command (Searching starts from preset frequency)	ON: Speed search					
			16	Acceleration/Deceleration-prohibit command	ON: Acceleration/Deceleration is on hold (running at parameter frequency)					
			17	Local or remote selection	ON: Local mode (operated with the Digital Operator)					
			18	Communications/remote selection	ON: Communications input is enabled.					

			19	Emergency stop fault (NO)	<p>The Inverter stops according to the setting in n005 for interruption mode selection with the emergency stop input turned ON.</p> <p>NO: Emergency stop with the contact closed. NC: Emergency stop with the contact opened.</p> <p>Fault: Fault output is ON and reset with RESET input. Alarm output is ON (no reset required).</p> <p>“STP” is displayed (lit with fault input ON and flashes with alarm input ON)</p> <p>ON: PID control disabled.</p> <p>ON: Integral value reset.</p> <p>ON: Keeps integral value on hold.</p> <p>ON: Displays inverter overheating warning (oH3)</p> <p>Up or down command (set in n56 only)</p> <p>By setting n56 to 34, the set value in n55 is ignored and the following setting are forcibly made. S6: Up command S7: Down command</p> <p>ON: RS-422/485 communications self-diagnostic test (set in n056 only)</p>					
			20	Emergency stop alarm (NO)						
			21	Emergency stop fault (NC)						
			22	Emergency stop alarm (NC)						
			23	PID control cancel						
			24	PID control integral reset						
			25	PID control integral hold						
			26 (see note)	Inverter overheating warning						
			34	Up or down command						
			35	Self-diagnostic test						

Note Available for 5.5kW and 7.5kW Inverters only.

Parameter No.	Register No.	Name	Description	Setting range	Unit of setting	Default setting	Changes during operation	Reference page		
n057	0139	Multi-function output 1 (MA/MB and MC output terminals)	Used to select the functions of multi-function output terminals.		0 to 7, 10 to 19 (21 see note)	1	0	No	5-38	
			Set value	Function						Description
n058	013A	Multi-function output 2 (P1-PC output terminals)	1	Operation in progress	ON: Operation in progress	0 to 7, 10 to 19 (21 see note)	1	1	No	5-38
			2	Frequency detection	ON: Frequency detection (with frequency reference coinciding with output frequency)					
			3	Zero speed	ON: Zero speed (at less than min. output frequency)					
n059	013B	Multi-function output 3 (P2-PC output terminals)	4	Frequency detection 1	ON: Output frequency <input type="checkbox"/> frequency detection level (n095)	0 to 7, 10 to 19 (21 see note)	1	2	No	5-38
			5	Frequency detection 2	ON: Output frequency <input type="checkbox"/> frequency detection level (n095)					
			6	Overtorque being monitored (NO-contact output)	Output if any of the following parameter conditions is satisfied. n096: Overtorque detection function selection 1 n097: Overtorque detection function selection 2					
			7	Overtorque being monitored (NC-contact output)	n098: Overtorque detection level n099: Overtorque detection time NO contact: ON with overtorque being detected NC contact: OFF with overtorque being detected					
			8	Not used	---					
			9							
			10	Alarm output	ON: Alarm being detected (Nonfatal error being detected)					
			11	Base block in progress	Base block in progress (in operation with output turned OFF)					
12	RUN mode	ON: Local mode (with the Digital Operator)								

Parameter No.	Register No.	Name	Description	Setting range	Unit of setting	Default setting	Changes during operation	Reference page																											
			<table border="1"> <tr> <td>13</td> <td>Inverter ready</td> <td>ON: Inverter ready to operate (with no fault detected)</td> </tr> <tr> <td>14</td> <td>Fault retry</td> <td>ON: Fault retry</td> </tr> <tr> <td>15</td> <td>UV in progress</td> <td>ON: Undervoltage being monitored</td> </tr> <tr> <td>16</td> <td>Rotating in reverse direction</td> <td>ON: Rotating in reverse direction</td> </tr> <tr> <td>17</td> <td>Speed search in progress</td> <td>ON: Speed search in progress</td> </tr> <tr> <td>18</td> <td>Communications output</td> <td>ON: Turns communications output 1 ON.</td> </tr> <tr> <td>19</td> <td>PID feedback loss</td> <td>ON: PID feedback loss enabled.</td> </tr> <tr> <td>20 (see note)</td> <td>Frequency reference loss</td> <td>ON: Frequency reference lost (when frequency reference loss detection in n064 is enabled, and either analog input or pulse train input is set for frequency reference selection in n004)</td> </tr> <tr> <td>21 (see note)</td> <td>Inverter overheating warning oH3</td> <td>ON: Inverter overheating warning (ON when the multi-function input Inverter overheating warning signal is being input, i.e., when OH3 is flashing.)</td> </tr> </table>	13	Inverter ready	ON: Inverter ready to operate (with no fault detected)	14	Fault retry	ON: Fault retry	15	UV in progress	ON: Undervoltage being monitored	16	Rotating in reverse direction	ON: Rotating in reverse direction	17	Speed search in progress	ON: Speed search in progress	18	Communications output	ON: Turns communications output 1 ON.	19	PID feedback loss	ON: PID feedback loss enabled.	20 (see note)	Frequency reference loss	ON: Frequency reference lost (when frequency reference loss detection in n064 is enabled, and either analog input or pulse train input is set for frequency reference selection in n004)	21 (see note)	Inverter overheating warning oH3	ON: Inverter overheating warning (ON when the multi-function input Inverter overheating warning signal is being input, i.e., when OH3 is flashing.)					
13	Inverter ready	ON: Inverter ready to operate (with no fault detected)																																	
14	Fault retry	ON: Fault retry																																	
15	UV in progress	ON: Undervoltage being monitored																																	
16	Rotating in reverse direction	ON: Rotating in reverse direction																																	
17	Speed search in progress	ON: Speed search in progress																																	
18	Communications output	ON: Turns communications output 1 ON.																																	
19	PID feedback loss	ON: PID feedback loss enabled.																																	
20 (see note)	Frequency reference loss	ON: Frequency reference lost (when frequency reference loss detection in n064 is enabled, and either analog input or pulse train input is set for frequency reference selection in n004)																																	
21 (see note)	Inverter overheating warning oH3	ON: Inverter overheating warning (ON when the multi-function input Inverter overheating warning signal is being input, i.e., when OH3 is flashing.)																																	
n060	013C	Frequency reference gain	Used to the input characteristics of analog frequency references. Gain: The frequency of maximum analog input (10 V or 20 mA) in percentage based on the maximum frequency as 100%.	0 to 255	1%	100	Yes	5-14																											
n061	013D	Frequency reference bias	Bias: The frequency of minimum analog input (0 V or 0 or 4 mA) in percentage based on the maximum frequency as 100%.	-100 to 100	1%	0	Yes	5-14																											
n062	013E	Analog frequency reference filter time	Used to set the digital filter with a first-order lag for analog frequency references to be input.	0.00 to 2.00	0.01 s	0.10	No	5-15																											
n063	---	Not used	---	---	---	---	---	---																											

Note Frequency reference loss (setting value: 20) and inverter overheating warning (setting value: 21) can be set for 5.5-kW and 7.5-kW Inverters only.

Parameter No.	Register No.	Name	Description	Setting range	Unit of setting	Default setting	Changes during operation	Reference page
n064	0140	Frequency reference loss detection (see note)	Selects the frequency loss detection function for when the frequency reference from the control circuit terminal suddenly drops.0: Disable (Operate according to frequency reference.)1: Enable (Continue operation at 80% of frequency reference prior to loss.)Note: Frequency reference loss: Frequency reference voltage drop of 90% within 400 ms. Note Applicable for software version No. 010024 or later	0,1	1	0	No	5-18
n065	0141	Multi-function analog output type selection	Select the multi-function analog output type. 0: Analog voltage output (functions set in n066) 1: Pulse train output (functions set in n150)	0, 1	1	0	No	5-41
n066	0142	Multi-function analog output	Selects the monitor item with n065 set to 0. 0: Output frequency (with 10-V output at max. frequency) 1: Output current (with 10-V output with Inverter rated output current) 2: Main circuit DC voltage (with 10-V output at 400 [800] VDC) 3: Vector operation torque monitor (with 10-V output at rated motor torque) 4: Output power (with 10-V output at power equivalent to max. applicable motor capacity) 5: Output voltage (with 10-V output at 200 [200] VAC) Note Values in () apply with n067 set to 1.00. Note Values in [] are for 400-V models.	0 to 5	1	0	No	5-41
n067	0143	Multi-function analog output gain	Used to set the output characteristics of multi-function analog output.	0.00 to 2.00	0.01	1.00	Yes	5-42
n068	0144	Multi-function analog voltage input gain	Set the input characteristics of multi-function analog voltage input. Gain: Set the frequency of maximum analog input (10 V) in percentage based on the maximum frequency as 100%.	-255 to 255	1%	100	Yes	5-17
n069	0145	Multi-function analog voltage input bias	Bias: Set the frequency of minimum analog input (0 V) in percentage based on the maximum frequency as 100%.	-100 to 100	1%	0	Yes	5-17
n070	0146	Multi-function analog voltage input filter time constant	Set a primary delay digital filter for multi-function analog voltage input.	0.00 to 2.00	0.01 s	0.10	Yes	5-17

Note Frequency reference loss (setting value: 20) can be set for 5.5-kW and 7.5-kW Inverters only.

Parameter No.	Register No.	Name	Description	Setting range	Unit of setting	Default setting	Changes during operation	Reference page
n071	0147	Multi-function analog current input gain	Set the input characteristics of multi-function analog current input. Gain: Set the frequency of maximum analog input (20 mA) in percentage based on the maximum frequency as 100%.	-255 to 255	1%	100	Yes	NO TAG
n072	0148	Multi-function analog current input bias	Bias: Set the frequency of minimum analog input (0 V) in percentage based on the maximum frequency as 100%.	-100 to 100	1%	0	Yes	NO TAG
n073	0149	Multi-function analog current input filter time constant	Set a primary delay digital filter for multi-function analog current input. 0.00 to 2.00	0.00 to 2.00	0.01 s	0.10	Yes	NO TAG
n074	014A	Pulse train frequency reference gain	Set the input characteristics of pulse train input. Gain: Set the gain in percentage based on the maximum frequency of the pulse train input scale in n149 as 100%.	-255 to 255	1%	100	Yes	5-25
n075	014B	Pulse train frequency reference bias	Bias: Set the bias in percentage for frequency reference input at 0-Hz pulse train input based on the maximum frequency as 100%.	-100 to 100	1%	0	Yes	5-24
n076	014C	Pulse train frequency reference input filter time constant	Sets the pulse train input's primary-delay digital filter for frequency reference.	0.00 to 2.00	0.01 s	0.10	Yes	5-25
n077	014D	Multi-function analog input terminal function selection	Selects the function allocated to the multi-function analog input terminal. 0: Disable multi-function analog input function. 1: Auxiliary frequency reference 2: Frequency gain 3: Frequency bias 4: Output voltage bias Note: When setting "3," also set the standard value for the bias in n079.	0 to 4	1	0	No	5-15
n078	014E	Multi-function analog input terminal selection	Selects whether voltage input or current input is to be used. 0: Enable multi-function analog voltage input (and disable current input). 1: Enable multi-function analog current input (and disable voltage input).	0,1	1	0	No	5-15
n079	014F	Multi-function input frequency bias	When "3" is set for n077, set the standard value for the bias as a percentage, taking the maximum frequency as 100%.	0 to 50	1%	10	No	5-15

■ Function Group 3 (n080 through n0119)

Parameter No.	Register No.	Name	Description	Setting range	Unit of setting	Default setting	Changes during operation	Reference page	
n080	0150	Carrier frequency selection	Used to set the carrier frequency. Note The default setting does not need any changes in normal operation. Note Refer to 6-4 <i>Setting the Carrier Frequency</i> for details.	1 to 4, 7 to 9	1	Varies with the capacity.	No	6-26	
n081	0151	Momentary power interruption compensation	Used to specify the processing that is performed when a momentary power interruption occurs. 0: Inverter stops operating 1: Inverter continues operating if power interruption is 0.5 s or less. 2: Inverter restarts when power is restored.	0 to 2	1	0	No	6-42	
n082	0152	Number of fault retries	Used set the number of times that reset and restart are automatically attempted for the Inverter when the Inverter has an overvoltage fault or overcurrent fault.	0 to 10	1	0	No	6-43	
n083	0153	Jump frequency 1		0.0 to 400	0.01 Hz	0.00	No	6-44	
n084	0154	Jump frequency 2		0.0 to 400	0.01 Hz	0.00	No	6-44	
n085	0155	Jump frequency 3		0.0 to 400	0.01 Hz	0.00	No	6-44	
n086	0156	Jump width		Note Set n083 to n085 to satisfy the following condition. $n083 \leq n084 \leq n085$	0.0 to 25.5	0.01 Hz	0.00	No	6-44
n087	0157	Accumulated operating time function selection (See note.)		Selects the operating status to be accumulated. 0: Accumulate the time that the Inverter power is ON (i.e., the time from when the power is turned ON until it is shut OFF). 1: Accumulate Inverter execution time (i.e., the time that forward or reverse signals are being input).	0,1	1	0	No	6-45
n088	0158	Accumulated operating time (See note.)	Sets the initial value for the accumulated operating time, with 10 h as 1. The accumulation begins from the set time. The accumulated operating time's monitor value (U-13) can be cleared to 0 by setting "0" here.	0 to 6550	1 = 10H	0	No	6-46	

Note Accumulated operating time can be selected with 5.5kW and 7.5kW Inverters only.

Parameter No.	Register No.	Name	Description	Setting range	Unit of setting	Default setting	Changes during operation	Reference page
n089	0159	DC injection braking current	Used to impose DC on the induction motor for braking control. Set the DC braking current in percentage based on the rated current of the Inverter as 100%.	0 to 100	1%	50	No	6-29
n090	015A	DC injection braking-to-stop time		0.0 to 25.5	0.1 s	0.5	No	6-29
n091	015B	Startup DC injection braking time		0.0 to 25.5	0.1 s	0.0	No	6-29
n092	015C	Stall prevention during deceleration	Used to select a function to change the deceleration time of the motor automatically so that there will be no overvoltage imposed on the motor during deceleration. 0: Stall prevention during deceleration enabled 1: Stall prevention during deceleration disabled Note Be sure to set the parameter to 1 when the Braking Resistor Unit or a braking resistor is used as an option.	0, 1	1	0	No	6-31
n093	015D	Stall prevention level during acceleration	Used to select a function to stop the acceleration of the motor automatically for stall prevention during acceleration. Set the level in percentage based on the rated current of the Inverter as 100%.	30 to 200	1%	170	No	6-32
n094	015E	Stall prevention level during operation	Used to select a function to reduce the output frequency of the Inverter automatically for stall prevention during operation. Set the level in percentage based on the rated current of the Inverter as 100%.	30 to 200	1%	160	No	6-32
n095	015F	Frequency detection level	Used to set the frequency to be detected. Note The parameter n57, n58 and n59 for multi-function output must be set for the output of frequency detection levels 1 and 2.	0.00 to 400.0	0.01 Hz	0.00	No	6-47
n096	0160	Overtorque detection function selection 1	Used to enable or disable overtorque detection and select the processing method after overtorque detection. 0: Overtorque detection disabled 1: Overtorque detection only when speed coincides and operation continues (issues alarm) 2: Overtorque detection only when speed coincides and output turned OFF (for protection) 3: Overtorque always detected and operation continues (issues alarm) 4: Overtorque always detected and output turned OFF (for protection)	0 to 4	1	0	No	6-35
n097	0161	Overtorque detection function selection 2	Select the item to detect overtorque. 0: Detected from output torque. 1: Detected from output current.	0, 1	1	0	No	6-36

Parameter No.	Register No.	Name	Description	Setting range	Unit of setting	Default setting	Changes during operation	Reference page
n098	0162	Overtorque detection level	Used to set overtorque detection level. Detection from output torque: Set in percentage based on the rated motor torque as 100%. Detection from output current: Set in percentage based on the rated Inverter output current as 100%.	30 to 200	1%	160	No	6-36
n099	0163	Overtorque detection time	Used to set the detection time of overtorque.	0.1 to 10.0	0.1 s	0.1	No	6-36
n100	0164	UP/DOWN frequency selection	Used to store the adjusted frequency reference with the UP/DOWN function. 0: Frequency not stored 1: Frequency stored The frequency must be on hold for 5 s or more.	0, 1	1	0	No	6-48
n101	0165	Speed search deceleration time	Note Only applicable for 200/400V, 5.5/7.5kW models Note Applicable for software version No. 010024 or later	0.0 to 10.0	0.1s	2.0	No	---
n102	0166	Speed search operation level	Note Only applicable for 200/400V, 5.5/7.5kW models Note Applicable for software version No. 010024 or later	0 to 200	1%	150	No	---
n103	0167	Torque compensation gain	Used to set the gain of the torque compensation function. Note The default setting does not need any changes in normal operation.	0.0 to 2.5	0.1	1.0	Yes	6-37
n104	0168	Torque compensation primary delay time constant	Set the response speed of the torque compensation function. Note Normally, the default setting does not need to be changed.	0.0 to 25.5	0.1 s	0.3	No	6-37
n105	0169	Torque compensation core loss	Set the core loss of the motor in use. Note Normally, the default setting does not need to be changed. Note This parameter is enabled in V/f control mode only.	0.0 to 6,550	0.1 W	Varies with the capacity.	No	6-38
n106	016A	Rated motor slip	Used to set the rated slip value of the motor in use. Note Used as the constant of the slip compensation function.	0.0 to 20.0	0.1 Hz	Varies with the capacity.	Yes	6-39
n107	016B	Motor phase to neutral resistance	Set this parameter to 1/2 of the phase to neutral resistance or phase-to-phase resistance of the motor. Note This parameter is used as a vector control constant.	0.000 to 65.50	0.001 Ω	Varies with the capacity	No	5-6 6-2

Parameter No.	Register No.	Name	Description	Setting range	Unit of setting	Default setting	Changes during operation	Reference page
n108	016C	Motor leakage inductance	Set the leakage inductance of the motor in use. Note This parameter is used as a vector control constant. Note The Inverter with the default setting in this parameter fully functions in vector control.	0.00 to 655.0	0.01 mH	Varies with the capacity.	No	6-2
n109	016D	Torque compensation limit	Set a limit on the torque compensation function in vector control mode. Note Normally, the default setting does not need to be changed. Note The Inverter in torque compensation control limits the torque at a current 1.5 times larger than the set value.	0 to 250	1%	150	No	6-3
n110	016E	Motor no-load current	Used to set the no-load current of the motor in use based on the rated motor current as 100%. Note Used as the constant of vector control and the slip compensation function.	0 to 99	1%	Varies with the capacity	No	5-6
n111	016F	Slip compensation gain	Used to set the gain of the slip compensation function. Note The default is set to 1.0 in vector control mode. Note The slip compensation function is disabled with n66 set to 0.0.	0.0 to 2.5	0.1	0.0	Yes	6-39
n112	0170	Slip compensation primary delay time	Used for the response speed of the slip compensation function. Note The default is set to 0.2 in vector control mode. Note The default setting does not need any changes in normal operation.	0.0 to 25.5	0.1 s	2.0	No	6-39
n113	0164	Slip compensation during regeneration	Selects the slip compensation function in regenerative operation. 0: Disabled 1: Enabled Note This parameter is valid only in vector control mode.	0, 1	1	0	No	6-40
n114		Not used	---	---	---	---	---	---

Parameter No.	Register No.	Name	Description	Setting range	Unit of setting	Default setting	Changes during operation	Reference page
n115	0173	Stall prevention level automatic suppression selection	<p>Selects whether or not to automatically decrease the level for stall prevention during operation if the frequency lies in a constant output range exceeding the frequency set in n013 for max. voltage frequency (a range greater than the rated motor frequency).</p> <p>0: Automatic suppression function disabled (the value of n094 is valid for any frequency)</p> <p>1: Automatic suppression function enabled.</p> <p>Note The operation level is decreased by $n094 \times (\text{max. voltage frequency/output frequency})$.</p> <p>Note The stall prevention function during operation operates according to the acceleration/deceleration time set in n116.</p>	0, 1	1	0	No	6-33
n116	0174	Stall prevention acceleration/deceleration time setting	<p>Sets the acceleration/deceleration time for the stall prevention function during operation.</p> <p>0: Accelerates or decelerates according to acceleration/deceleration time 1 or 2, whichever is selected.</p> <p>1: Accelerates or decelerates according to acceleration/deceleration time 2. (n021/n022).</p> <p>Note When a faster (or slower) acceleration/deceleration time is desired, set this parameter to "1" and set the desired acceleration/deceleration time for stall prevention operation in acceleration/deceleration time 2.</p>	0, 1	1	0	No	6-34
n117	0175	Undertorque detection selection	<p>0: Undertorque detection not provided</p> <p>1: Detected during constant-speed running. Operation continues after detection.</p> <p>2: Detected during constant-speed running. Operation stops during detection.</p> <p>3: Detected during running. Operation continues after detection.</p> <p>4: Detected during running. Operation stops during detection.</p> <p>(1) To detect undertorque at accel/decel, set to 3 or 4.</p> <p>(2) To continue the operation after undertorque detection, set to 1 or 3.</p> <p>(3) To stop the inverter by a fault at undertorque detection, set 2 or 4.</p> <p>Note Applicable for software version No. 010024 or later.</p>	0,1	1	0		

Parameter No.	Register No.	Name	Description	Setting range	Unit of setting	Default setting	Changes during operation	Reference page
n118	0176	Undertorque detection level	Sets undertorque detection current level. (Inverter rated current=100%) If detection by torque is selected (n097), motor rated torque becomes 100%. Overtorque detection function selection 2 (n097) is used both for overtorque and undertorque detection. Note Applicable for software version No. 010024 or later.	0 to 200%	1%	10%		
n119	0177	Undertorque detection time	If time in which motor current falls below the undertorque detection level (n118) is longer than undertorque detection time, the undertorque detection function operates. Note Applicable for software version No. 010024 or later.	0.1 to 10.0 sec	0.1 sec	0.1 sec		

■ Function Group 4 (n120 through n179)

Parameter No.	Register No.	Name	Description	Setting range	Unit of setting	Default setting	Changes during operation	Reference page
n120	0178	Frequency reference 9	Set the internal frequency references. Note These frequency references are selected with multi-step speed references (multi-function inputs). See the reference pages for the relationship between multi-step frequency references and frequency references.	0.00 Hz to max.	0.01 Hz (Changeable with n035 settings)	0.00	Yes	5-20
n121	0179	Frequency reference 10				0.00	Yes	5-20
n122	017A	Frequency reference 11				0.00	Yes	5-20
n123	017B	Frequency reference 12				0.00	Yes	5-20
n124	017C	Frequency reference 13				0.00	Yes	5-20
n125	017D	Frequency reference 14				0.00	Yes	5-20
n126	017E	Frequency reference 15				0.00	Yes	5-20
n127	017F	Frequency reference 16				0.00	Yes	5-20
n128	0180	PID control selection	Selects the PID control method. 0: PID control disabled. 1 to 8: PID control enabled. Note The derivative control method (i.e., the derivative control of the deviation or detected value), the addition of the frequency reference, and the positive or negative characteristics of PID control are selectable.	0 to 8	1	0	No	6-18

Parameter No.	Register No.	Name	Description	Setting range	Unit of setting	Default setting	Changes during operation	Reference page
n129	0181	Feedback value adjustment gain	Set the value by which the feedback value is multiplied. Note This parameter is used for adjusting the target and detected values so that they will have the same input level.	0.00 to 10.00	0.01	1.00	Yes	6-18
n130	0182	Proportional (P) gain	Set the proportional (P) gain for PID control. Note PID control is disabled with this parameter set to 0.0.	0.0 to 25.0	0.1	1.0	Yes	6-19
n131	0183	Integral (I) time	Set the integral (I) time for PID control. Note Integral control is disabled with this parameter set to 0.0.	0.0 to 360.0	0.1 s	1.0	Yes	6-19
n132	0184	Derivative (D) time	Set the derivative (D) time for PID control. Note Derivative control is disabled with this parameter set to 0.0.	0.00 to 2.50	0.01 s	0.00	Yes	6-19
n133	0185	PID offset adjustment	This parameter is for the offset adjustment of all PID control. Set the parameter in percentage based on the maximum frequency as 100%.	-100 to 100	1%	0	Yes	6-19
n134	0186	Integral (I) upper limit	Set the upper limit value of integral control output. Set the parameter in percentage based on the maximum frequency as 100%.	0 to 100	1%	100	Yes	6-19
n135	0187	PID primary delay time	Set this parameter to the primary delay time constant for the frequency reference after PID control. Note Normally, the default setting does not need to be changed.	0.0 to 10.0	0.1 s	0.0	Yes	6-20
n136	0188	Feedback loss detection selection	Set the detection method of feedback loss in PID control. 0: Feedback loss detection disabled. 1: Feedback loss detection enabled (Nonfatal error: FbL warning) 2: Feedback loss detection enabled (Fatal error: FbL error)	0 to 2	1	0	No	6-20
n137	0189	Feedback loss detection level	Sets the detection level of feedback loss. Set the parameter in percentage based on the feedback value equivalent to the maximum frequency as 100%.	0 to 100	1%	0	No	6-20
n138	018A	Feedback loss detection time	Set the detection time of feedback loss. Note If the detection level set in n137 or lower is detected for the set time in n138, the result will be determined as feedback loss.	0.0 to 25.5	0.1 s	1.0	No	6-20

Parameter No.	Register No.	Name	Description	Setting range	Unit of setting	Default setting	Changes during operation	Reference page
n139	018B	Energy-saving control selection	Select the energy-saving control function. 0: Disabled 1: Enabled Note This parameter is enabled in V/f control mode only.	0, 1	1	0	No	6-7
n140	018C	Energy-saving control coefficient K2	Set the coefficient for the primary level of energy-saving control. Note The constant automatically changes according to the motor code in n158. Make fine adjustments of the contact if necessary after setting the motor code in n158.	0.0 to 6.550	0.1	Varies with the capacity	No	6-8
n141	018D	Energy-saving voltage lower limit at 60-Hz output	These parameters prevent the output voltage of the Inverter from dropping excessively so that the motor will not stall or come to a stop at the primary level of energy-saving control.	0 to 120	1%	50	No	6-9
n142	018E	Energy-saving voltage upper limit at 6-Hz output	Set the lower limit of output voltage in percentage at each frequency based on the rated motor voltage as 100%. Note Normally, the default settings do not need to be changed.	0 to 25	1%	12	No	6-9
n143	018F	Power averaging time	Set the time required to calculate the average of power used in energy-saving control. Power averaging time (ms) = Set value x 24 (ms) Note Normally, the default setting does not need to be changed.	1 to 200	1 (24 ms)	1	No	6-9
n144	0190	Probe operation voltage limit	Set the range of voltage control for the secondary level of energy-saving control. Set the parameter in percentage based on the rated motor voltage as 100%. Note No probe operation is available with the parameter set to 0.	0 to 100	1%	0	No	6-10
n145	0191	Probe operation control voltage step at 100%	Set the range of probe operation voltage in percentage based on the rated motor voltage as 100%. Note Normally, the default setting does not need to be changed.	0.1 to 10.0	0.1%	0.5	No	6-11
n146	0192	Probe operation control voltage step at 5%		0.1 to 10.0	0.1%	0.2	No	6-11
n147	---	Not used	---	---	---	---	---	---
n148								

Parameter No.	Register No.	Name	Description	Setting range	Unit of setting	Default setting	Changes during operation	Reference page
n149	0195	Pulse train input scale	<p>Set this parameter to the pulse train input scale so that frequency references can be executed by pulse train input.</p> <p>Set the maximum pulse train frequency in 10-Hz increments based on 10 Hz as 1.</p> <p>Note This parameter is enabled with n004 for frequency reference selection set to 5.</p>	100 to 3,300	1 (10 Hz)	2,500	No	5-25
n150	0196	Multi-function analog output, pulse train frequency selection.	<p>Select the relationship between the pulse train output frequency and output frequency.</p> <p>0: 1,440 Hz at max. frequency (A proportional relationship is applied to frequencies less than the maximum frequency)</p> <p>1: 1x output frequency</p> <p>6: 6x output frequency</p> <p>12: 12x output frequency</p> <p>24: 24x output frequency</p> <p>36: 36x output frequency</p> <p>Note This parameter is enabled with n065 set to 1.</p>	0, 1, 6, 12, 24, 36	1	0	No	5-42
n151	0197	RS-422/485 communications time-over detection selection	<p>The set value in the parameter determines whether communications time-over detection will be performed with "CE" displayed if there is an interval of more than 2 s between normal communications and how the detected communications time-over will be processed.</p> <p>0: Detects time-over, fatal error, and the Inverter coasts to a stop.</p> <p>1: Detects time-over, detects fatal error, and the Inverter decelerates to a stop in deceleration time 1.</p> <p>2: Detects time-over, detects fatal error, and the Inverter decelerates to a stop in deceleration time 2.</p> <p>3: Detects time-over, detects nonfatal error warning, and the Inverter continues operating.</p> <p>4: No time-over is detected.</p>	0 to 4	1	0	No	7-2

Parameter No.	Register No.	Name	Description	Setting range	Unit of setting	Default setting	Changes during operation	Reference page
n152	0198	RS-422/485 communications frequency reference/display unit selection	Set the unit of frequency reference and frequency-related values to be set or monitored through communications. 0: 0.1 Hz 1: 0.01 Hz 2: Converted value based on 30,000 as max. frequency 3: 0.1% (Max. frequency: 100%)	0 to 3	1	0	No	7-3
n153	0199	RS-422/485 communications Slave address	Set this parameter to the Slave address (Slave unit number) for communications. 00: Broadcast message (with the communications function disabled) 01 to 32: Slave address	00 to 32	1	00	No	7-4
n154	019A	RS-422/485 baud rate selection	Select the communications baud rate. 0: 2,400 bps 1: 4,800 bps 2: 9,600 bps 3: 19,200 bps	0 to 3	1	2	No	7-4
n155	019B	RS-422/485 parity selection	Select the parity check function for communications data. 0: Even 1: Odd 2: No parity	0 to 2	1	0	No	7-4
n156	019C	RS-422/485 send wait time	Set the time to wait for a response after the DSR (data-send-request) message is received from the Master.	10 to 65	1 ms	10	No	7-5
n157	019D	RS-422/485 RTS control selection	Select whether or not to enable the RTS (request-to-send) communications control function. 0: RTS control disabled 1: RTS control enabled (available to 1-to-1 RS-422 communications only)	0, 1	1	0	No	7-5
n158	019E	Motor code	Set the code to automatically set the constants for energy-saving control. 0 to 8: 200-VAC, 0.1- to 4.0-kW motor 20 to 28: 400-VAC, 0.1- to 4.0-kW motor	0 to 70	1	Varies with the capacity.	No	6-7
n159	019F	Energy-saving voltage upper limit at 60-Hz output	These parameters prevent the motor from over excitation due to voltage changes during energy-saving control.	0 to 120	1%	120	No	6-10
n160	01A0	Energy-saving lower limit voltage at 6-Hz output	Set the upper limit of output voltage in percentage at each frequency based on the rated motor voltage as 100%. Note Normally, the default settings do not need to be changed.	0 to 25	1%	16	No	6-10

Parameter No.	Register No.	Name	Description	Setting range	Unit of setting	Default setting	Changes during operation	Reference page
n161	01A1	Power detection width for probe operation switching	Set the detection width of power that sets the Inverter into probe operation. Set the width in percentage based on the power to be detected as 100%. Note Normally, the default setting does not need to be changed. Note The Inverter will operate with a power detection width of 10% if the value is set to 0.	0 to 100	1%	10	No	6-11
n162	01A2	Power detection filter constant	Set the filter time constant of the power detection block of the Inverter operating in probe operation. Filter time constant (ms) = Set value in n162 x 4 (ms) Note Normally, the default setting does not need to be changed. Note The Inverter will operate with a time constant of 20 ms if the value is set to 0.	0 to 255	1 (4 ms)	5	No	6-12
n163	01A3	PID output gain	Set the rate by which PID control value is multiplied for PID control. Note Normally, the default setting does not need to be changed.	0.0 to 25.0	0.1	1.0	No	6-21
n164	01A4	PID feedback input block selection	Set the feedback input block for PID control detection. 0: Frequency reference control terminal for voltage input (0 to 10 V) is enabled. 1: Frequency reference control terminal for current input (4 to 20 mA) is enabled. 2: Frequency reference control terminal for current input (0 to 20 mA) is enabled. 3: Multi-function analog voltage input (0 to 10 V) is enabled. 4: Multi-function analog current input (0 to 20 mA) is enabled. 5: Pulse train reference control terminal is enabled. Note Make sure that the target value input and feedback value input do not overlap with each other.	0 to 5	1	0	No	6-21
n165	01A5	Installed braking resistor overheating protection (see note 1)	0: Overheating protection disabled 1: Overheating protection enabled	0,1	1	0	No	---

Parameter No.	Register No.	Name	Description	Setting range	Unit of setting	Default setting	Changes during operation	Reference page
n166	01A6	Input open-phase detection level (see note 1)	Sets the main circuit DC voltage fluctuation level, as a percentage, for detecting an input open phase. 200-V-class Inverters: Set 400 V as 100%. 400-V-class Inverters: Set 800 V as 100%. If "0" is set, the input open-phase detection function will be disabled. Recommended setting: 7 (%) Note Applicable for software version No. 010024 or later.	0 to 100	1%	0	No	6-50
n167	01A7	Input open-phase detection time (see note 1)	Sets the input open-phase detection time in units of seconds. If "0" is set, the input open-phase detection function will be disabled. Recommended setting: 10 (s) Note Applicable for software version No. 010024 or later.	0 to 255	1s	0	No	6-50
n168	01A8	Output open-phase detection level (see note 1)	Sets as a percentage the current for detecting an output open phase, taking the Inverter's rated output current as 100%. If "0" is set, the output open-phase detection function will be disabled. Recommended setting: 5 (%) Note Applicable for software version No. 010024 or later.	0 to 100	1%	0	No	6-51
n169	01A9	Output open-phase detection time (see note 1)	Sets the output open-phase detection time in units of seconds. If "0" is set, the output open-phase detection function will be disabled. Recommended setting: 0.2 (s) Note Applicable for software version No. 010024 or later.	0.0 to 2.0	0.1s	0.0	No	6-51
n170 to n172	---	Not used	---	---	---	---	---	---
n173	01AD	DC injection P gain	Adjust the response of the DC injection with the proportional gain (P). Note Applicable for software version No. 010024 or later.	1 to 999	1 (=0.001)	83 (=0.083)		
n174	01AE	DC injection I time	Adjust the response of the DC injection with the integral time (I). Note Applicable for software version No. 010024 or later.	1 to 250	1 (=4ms)	25 (=100ms)		

Parameter No.	Register No.	Name	Description	Setting range	Unit of setting	Default setting	Changes during operation	Reference page
n175	01AF	Low carrier frequency at low speed	<p>This function automatically reduces the carrier frequency to 2.5 kHz if the output frequency is 5 kHz or less, and the output current is 110% or greater than the rated Inverter current. Normally this setting is not necessary. This function improves the overload capacity at low frequencies.</p> <p>0: Low carrier frequency at low speed disabled.</p> <p>1: Low carrier frequency at low speed enabled.</p> <p>Note Normally, it is not necessary to change the default setting.</p> <p>Note This function is enabled if n080 (carrier frequency) is set to 2, 3, or 4.</p>	0, 1	1	0 (see note 2)	No	6-28
n176	01B0	Parameter copy and verify function selection	<p>Select the function to read, copy, and verify the parameter between the memory of the Inverter and that of the Digital Operator.</p> <p>rdy: Ready to accept the next command.</p> <p>rEd: Reads the Inverter parameter.</p> <p>Cpy: Copies the parameter to the Inverter.</p> <p>vFy: Verifies the Inverter parameter.</p> <p>vA: Checks the Inverter capacity display.</p> <p>Sno: Checks the software number.</p> <p>Note No parameters can be copied to the Inverter in RUN operation.</p>	rdy to Sno	---	rdy	Yes	3-10
n177	01B1	Parameter read prohibit selection	<p>Select the copy-prohibit function.</p> <p>Set this parameter to store the data in the EEPROM of the Digital Operator.</p> <p>0: Read prohibited for Inverter parameters (data cannot be stored in EEPROM).</p> <p>1: Read possible for Inverter parameters (data can be stored in EEPROM).</p>	0, 1	1	0	Yes	3-17

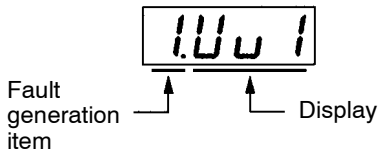
Parameter No.	Register No.	Name	Description	Setting range	Unit of setting	Default setting	Changes during operation	Reference page
n178	01B2	Fault log	<p>Used to display the four most recent faults recorded.</p>  <p>Note This parameter is monitored only.</p>	---	---	---	---	6-52
n179	01B3	Software number	<p>Used to display the software number of the Inverter for OMRON's control reference use.</p> <p>Note This parameter is monitored only.</p>	---	---	---	---	---

Note 1. Available for 5.5-kW and 7.5-kW Inverters only.

Note 2. The default setting for 5.5-kW and 7.5-kW Inverters is "1."

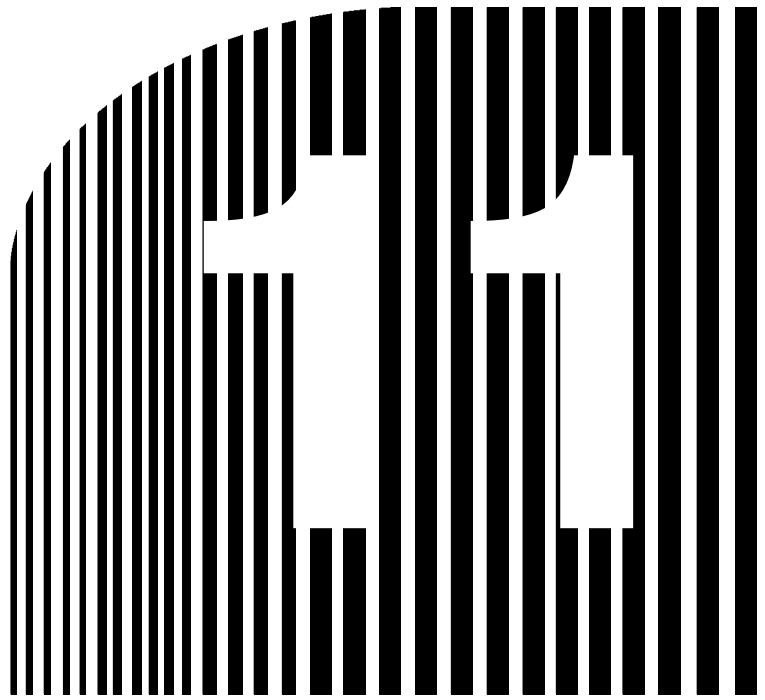

Chapter 11

- **Using the Inverter for a Motor •**

■ Using Inverter for Existing Standard Motor

When a standard motor is operated with the Inverter, a power loss is lightly higher than when operated with a commercial power supply.

In addition, cooling effects also decline the low-speed range, resulting in an increase in the motor temperature. Therefore, motor torque should be reduced in the low speed range.

The following figure shows allowable load characteristics of a standard motor.

If 100% torque is continuously required in the low-speed range, use a special motor for use with Inverters.

Allowable Load Characteristics of Standard Motor

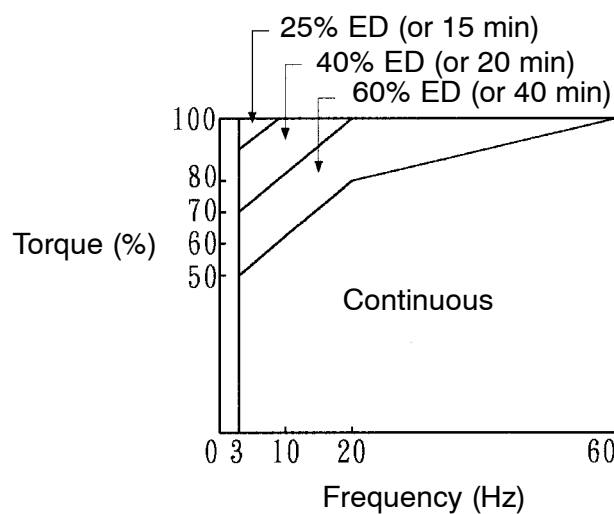

● High-speed Operation

When using the motor at high-speed (above the motor rated frequency), problems may arise in dynamic balance and bearing durability.

● Torque Characteristics

The motor may require more acceleration torque when the motor is operated with the Inverter than when operated with a commercial power supply. Check the load torque characteristics of the machine to be used with the motor to set a proper V/f pattern.

● **Vibration**

The 3G3MV Series employs high carrier PWM control to reduce motor vibration. When the motor is operated with the Inverter, motor vibration is almost the same as when operated with a commercial power supply.

Motor vibration may, however, become greater in the following cases.

- Resonance with the natural frequency of the mechanical system

Take special care when a machine that has been operated at a constant speed is to be operated in variable speed mode.

If resonance occurs, install vibration-proof rubber on the motor base.

- Imbalance rotor

Take special care when the motor is operated at a high speed (50 Hz or more).

● **Noise**

Noise is almost the same as when the motor is operated with a commercial power supply. Motor noise, however, becomes louder when the motor is operated at a speed higher than the rated speed (50 Hz).

■ **Using Inverter for Special Motors**

● **Pole-changing Motor**

The rated input current of pole-changing motors differs from that of standard motors. Select, therefore, an appropriate Inverter according to the maximum input current of the motor to be used.

Before changing the number of poles, always make sure that the motor has stopped.

Otherwise, the overvoltage protective or overcurrent protective mechanism will be actuated, resulting in an error.

● **Submersible Motor**

The rated input current of submersible motors is higher than that of standard motors. Therefore, always select an Inverter by checking its rated output current.

When the distance between the motor and Inverter is long, use a cable thick enough to connect the motor and Inverter to prevent motor torque reduction.

● **Explosion-proof Motor**

When an explosion-proof motor or increased safety-type motor is to be used, it must be subject to an explosion-proof test in conjunction with the Inverter. This is also applicable when an existing explosion-proof motor is to be operated with the Inverter.

● **Gearmotor**

The speed range for continuous operation differs according to the lubrication method and motor manufacturer. In particular, the continuous operation of an oil-lubricated motor in the low speed range may result in burning. If the motor is to be operated at a speed higher than 60 Hz, consult with the manufacturer.

● **Synchronous Motor**

A synchronous motor is not suitable for Inverter control.

If a group of synchronous motors is individually turned on and off, synchronism may be lost.

● **Single-phase Motor**

Do not use the Inverter for a single-phase motor.

The motor should be replaced with a 3-phase motor.

■ **Power Transmission Mechanism (Speed Reducers, Belts, and Chains)**

If an oil-lubricated gear box or speed reducer is used in the power transmission mechanism, oil lubrication will be affected when the motor operates only in the low speed range. The power transmission mechanism will make noise and experience problems with service life and durability if the motor is operated at a speed higher than 50 Hz.

■ **Motor Burnout Caused by Insufficient Dielectric Strength of Each Phase of Motor**

Surge occurs among the phases of the motor when the output voltage is switched.

If the dielectric strength of each phase of the motor is insufficient, the motor may burn out.

The dielectric strength of each phase of the motor must be higher than the maximum surge voltage. Normally, the maximum surge voltage is approximately three times the power voltage imposed on the Inverter.

Be sure to connect Inverter-dedicated motors if the Inverter is a 400-V-class model. Standard motors do not have sufficient dielectric strength and may burn out.

Revision History

A manual revision code appears as a suffix to the catalog number on the front cover of the manual.

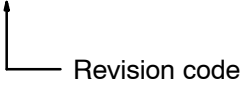
Cat. No. I527-E2-02

The following table outlines the changes made to the manual during each revision. Page numbers refer to the previous version.

Revision code	Date	Revised content
1 (I527-E1-1)	May 1999	Original production
01	April 2000	<p>European version</p> <p>New Inverters with different capacities added: 3G3MV-A2055/A2075/A4055/A4075. New functions added for with 5.5-/7.5-kW Inverters, new 3G3IV-PFN□ Input-side Noise Filter added, and general revisions and corrections made. Specific changes are as follows:</p> <p>Preliminary: Information added on installation types.</p> <p>Page 1-2: Information added on enclosure ratings and motor capacity.</p> <p>Page 1-7, 3-3: Information added on Reset Key. Note added after table.</p> <p>Pages 1-8: Summary of new features added.</p> <p>Page 2-4: Information added on dimensions and weight of new models.</p> <p>Page 2-5: "Caution" notices changed to "Warning" notices.</p> <p>Page 2-6: Information added on ambient operating temperatures, Inverter weights, and installing Inverters in control panels.</p> <p>Page 2-8: Description changed.</p> <p>Page 2-9: Information added on removing the terminal cover and bottom cover.</p> <p>Page 2-12, 2-19, 2-20: Information added for new models.</p> <p>Page 2-14, 2-34, 3-7, 5-4, 5-8, 5-30, 5-35, 5-32, 7-27, 9-2, 9-4, 9-7, 10-4, 6-27 to 6-28, 10-12, 10-14, 10-16, 10-17, 10-19, 10-26: Information added to tables. Notes added after tables.</p> <p>Page 2-22: Information added on circuit breaker installation.</p> <p>Page 2-23: Information added on magnetic contactors.</p> <p>Page 2-24: Information added on noise filters.</p> <p>Page 2-27: Information added on cable length.</p> <p>Page 2-34: Information added on Braking Resistor and Braking Resistor Unit.</p> <p>Page 2-35: Information added to wiring diagram and table. Note added after table.</p> <p>Page 2-39, 2-41, 6-8, 8-5, 8-8, 7-28, 8-9 to 8-13, 8-26, 9-10, 9-12, 9-14, 9-18, 9-19, 9-28: Information added to table.</p> <p>Page 3-8, 3-9, 5-30: Notes added after table.</p> <p>Page 3-11: Information added on motor capacities.</p> <p>Page 3-12, 3-16, 7-12, 7-15: Notes added.</p>

Revision History

Revision code	Date	Revised content
		<p>Page 5-10: Information added on remote/local selection methods.</p> <p>Page 5-14: Information added on frequency referencing by analog inputs.</p> <p>Page 5-15: Information added on multi-function analog inputs.</p> <p>Page 5-16: Information added on multi-function analog inputs and frequency reference loss detection.</p> <p>Page 5-24: Information added on pulse train frequency reference input filter time constant.</p> <p>Page 5-34: Information added on external base block command and speed search. Information added to table. Note added after table.</p> <p>Page 6-4, 6-5, 6-20, 7-27: Changes made in table.</p> <p>Page 6-6: Information added on energy-saving control.</p> <p>Page 6-45: Information added on accumulated operating time.</p> <p>Page 6-50: Information added on input and output open-phase detection.</p> <p>Page 7-5: Correction made to section heading. Information added on baud rate, parity, and RTS control selection.</p> <p>Page 7-9: Information added on message intervals.</p> <p>Page 7-10: Information added on message data configuration.</p> <p>Page 7-11: Information added on error checks.</p> <p>Page 7-22: Bit status changed.</p> <p>Page 7-26, 7-27, 9-27, 8-26: Correction made to heading.</p> <p>Page 8-16: Information added on multi-function inputs.</p> <p>Page 8-23: Information added on sequence errors and unwanted current paths. Diagram added.</p> <p>Page 9-7, 9-15: Model number changed.</p> <p>Page 9-21, 9-24: Diagram added</p> <p>Page 9-25: Information added to table. Diagram added.</p> <p>Page 9-26: Information on input noise filters deleted.</p>
02	October 2001	<p>Preliminary: Information about Software option removed.</p> <p>Page 1-3: Terminology changed.</p> <p>Page 1-6: Information on MNTR indicator changed.</p> <p>Page 1-8: Information added on Overheating Warning Input.</p> <p>Page 1-9: Information about New Features removed.</p> <p>Page 2-6: Information about inverter's capacity changed.</p> <p>Page 2-11: Terminology changed.</p> <p>Page 2-12: Illustration of Main Circuit Terminals modified.</p> <p>Page 2-15: Information on CN2 indicator added.</p> <p>Page 2-18: Switch number corrected.</p> <p>Page 2-19: Information about default setting changed.</p> <p>Page 2-26: Information on Installing an AC Reactor changed.</p> <p>Page 2-27: Information on usage of noise filters added. Information on connecting the Terminal Block to the Load added.</p> <p>Page 2-28: Illustration modified. Note added after illustration.</p> <p>Page 2-34: Information on AC and DC Reactors added.</p> <p>Page 2-37: Information about Braking Resistor type changed. Illustration and dimensions of the Braking Resistor Unit added.</p> <p>Page 2-43: Information about rated current changed.</p> <p>Page 3-2: Terminology changed.</p>

Revision History

Revision code	Date	Revised content
		<p>Page 3-4: Indicators name corrected. Value set corrected. Note added after table.</p> <p>Page 3-7: Terminal information changed. Accumulated operating time corrected.</p> <p>Page 3-15: Terminology changed.</p> <p>Page 3-18: Parameter corrected.</p> <p>Page 5-3: Terminology changed.</p> <p>Page 5-4: Information in Note 1 changed.</p> <p>Page 5-6: Terminology changed.</p> <p>Page 5-10: Parameter changed in "Basic Concept" table.</p> <p>Page 5-12: Number of frequency references changed.</p> <p>Page 5-14: Information added to note.</p> <p>Page 5-15: Note added at the end of the page.</p> <p>Page 5-17: Information about Minimum analog input changed.</p> <p>Page 5-23: Terminology changed.</p> <p>Page 5-25: Explanation of ED added.</p> <p>Page 5-31: Terminology changed.</p> <p>Page 5-35: Setting corrected.</p> <p>Page 5-31: Terminology changed.</p> <p>Page 5-38: Information about Multi-function digital Outputs changed.</p> <p>Page 5-39: Terminology changed.</p> <p>Page 5-41: Information about Multi-function digital Outputs changed.</p> <p>Page 5-43: Value "0" description changed.</p> <p>Page 6-2: Class information changed.</p> <p>Page 6-19: Terminology changed.</p> <p>Page 6-21: Information added.</p> <p>Page 6-28: Terminology changed.</p> <p>Page 6-33: Parameter changed.</p> <p>Page 6-34: Added description to the illustration.</p> <p>Page 6-34: Information added.</p> <p>Page 7-8: Software information changed.</p> <p>Page 9-8: Rated current information changed.</p> <p>Page 11-2: Terminology changed.</p> <p>Page 11-3: Information on vibration and noise changed.</p> <p>Page 11-4: Information on Power Transmission Mechanism changed.</p>

Revision History

OMRON

Regional Headquarters

OMRON EUROPE B.V.

Wegalaan 67-69

NL - 2132 JD Hoofddorp

The Netherlands

Tel.: +31 (0)23 56 81 300

Fax: +31 (0)23 56 81 388

Website: www.eu.omron.com

Authorized Distributor: