



YASKAWA

# YASKAWA AC Drive-Option Card PROFIBUS-DP Installation Manual

Type SI-P3

To properly use the product, read this manual thoroughly and retain for easy reference, inspection, and maintenance. Ensure the end user receives this manual.

## 安川インバータ オプションカード PROFIBUS-DP通信 取扱説明書

形式 SI-P3

製品を安全にお使い頂くために、この取扱説明書を必ずお読みください。  
また、本書をお手元に保管していただくとともに、最終的に本製品をご使用になるユーザー様のお手元に確実に届けられるよう、お取り計らい願います。

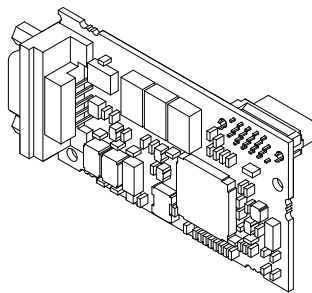

**This Page Intentionally Blank**



# Table of Contents

---

<b>1 PREFACE AND SAFETY .....</b>	<b>5</b>
<b>2 PRODUCT OVERVIEW .....</b>	<b>9</b>
<b>3 RECEIVING .....</b>	<b>10</b>
<b>4 PROFIBUS-DP OPTION COMPONENTS .....</b>	<b>11</b>
<b>5 INSTALLATION PROCEDURE .....</b>	<b>15</b>
<b>6 PROFIBUS-DP OPTION DRIVE PARAMETERS .....</b>	<b>23</b>
<b>7 PROFIBUS-DP OPTION DATA AND I/O MAPS .....</b>	<b>25</b>
<b>8 TROUBLESHOOTING .....</b>	<b>30</b>
<b>9 SPECIFICATIONS .....</b>	<b>34</b>

---

## **Copyright © 2008 YASKAWA ELECTRIC CORPORATION**

All rights reserved. No part of this publication may be reproduced, stored in a retrieval system, or transmitted, in any form or by any means, mechanical, electronic, photocopying, recording, or otherwise, without the prior written permission of Yaskawa. No patent liability is assumed with respect to the use of the information contained herein. Moreover, because Yaskawa is constantly striving to improve its high-quality products, the information contained in this manual is subject to change without notice. Every precaution has been taken in the preparation of this manual. Yaskawa assumes no responsibility for errors or omissions. Neither is any liability assumed for damages resulting from the use of the information contained in this publication.

# 1 Preface and Safety

Yaskawa manufactures products used as components in a wide variety of industrial systems and equipment. The selection and application of Yaskawa products remain the responsibility of the equipment manufacturer or end user. Yaskawa accepts no responsibility for the way its products are incorporated into the final system design. Under no circumstances should any Yaskawa product be incorporated into any product or design as the exclusive or sole safety control. Without exception, all controls should be designed to detect faults dynamically and fail safely under all circumstances. All systems or equipment designed to incorporate a product manufactured by Yaskawa must be supplied to the end user with appropriate warnings and instructions as to the safe use and operation of that part. Any warnings provided by Yaskawa must be promptly provided to the end user. Yaskawa offers an express warranty only as to the quality of its products in conforming to standards and specifications published in the Yaskawa manual. **NO OTHER WARRANTY, EXPRESS OR IMPLIED, IS OFFERED.** Yaskawa assumes no liability for any personal injury, property damage, losses, or claims arising from misapplication of its products.

## ◆ Applicable Documentation

The following manuals are available for the PROFIBUS-DP option card:

### Option Card

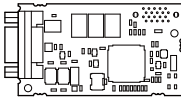
	<p><b>Yaskawa AC Drive-Option Card PROFIBUS-DP Installation Manual (This book)</b>  <b>Manual No.: TOBPC73060042</b></p>
	<p>Read this manual first.          The installation manual is packaged with the PROFIBUS-DP Option and contains a basic overview of wiring, settings, functions, and fault diagnoses.</p>
	<p><b>Yaskawa AC Drive-Option Card PROFIBUS-DP Technical Manual</b>  <b>Manual No.: SIEPC73060042</b></p>
	<p>The technical manual contains detailed information and command registers.          To obtain the technical manual access these sites:          Europe: <a href="http://www.yaskawa.eu.com">http://www.yaskawa.eu.com</a>          Japan: <a href="http://www.e-mechatronics.com">http://www.e-mechatronics.com</a>          Other areas: contact a Yaskawa representative.</p>

### Yaskawa Drive

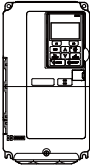
	<p>Refer to the manual of the drive this option card is being used with.          The instruction manual for the drive covers basic installation, wiring, operation procedures, functions, troubleshooting, and maintenance information.          It also includes important information on parameter settings and how to tune the drive.          A Quick Start Guide is included with the drive. For the more detailed Technical Manual, visit Yaskawa's homepage, <a href="http://www.e-mechatronics.com">http://www.e-mechatronics.com</a>.</p>
---	---

# 1 Preface and Safety

---

## ◆ Terms

**Note:** Indicates a supplement or precaution that does not cause drive damage.

**PROFIBUS Option:** Yaskawa AC Drive PROFIBUS-DP option card

---

## ◆ Registered Trademarks

- PROFIBUS-DP is a registered trademark of PROFIBUS International.
  - Other company names and product names listed in this manual are registered trademarks of those companies.
- 

## ◆ Supplemental Safety Information

Read and understand this manual before installing, operating, or servicing this option card. The option card must be installed according to this manual and local codes.

The following conventions are used to indicate safety messages in this manual. Failure to heed these messages could result in serious or possibly even fatal injury or damage to the products or to related equipment and systems.

### **DANGER**

Indicates a hazardous situation, which, if not avoided, will result in death or serious injury.

### **WARNING**

Indicates a hazardous situation, which, if not avoided, could result in death or serious injury.

### **CAUTION**

Indicates a hazardous situation, which, if not avoided, could result in minor or moderate injury.

## NOTICE

Indicates an equipment damage message.

### ■ General Safety

#### General Precautions

- The diagrams in this section may include option cards and drives without covers or safety shields to illustrate details. Be sure to reinstall covers or shields before operating any devices. The option board should be used according to the instructions described in this manual.
- Any illustrations, photographs, or examples used in this manual are provided as examples only and may not apply to all products to which this manual is applicable.
- The products and specifications described in this manual or the content and presentation of the manual may be changed without notice to improve the product and/or the manual.
- When ordering a new copy of the manual due to damage or loss, contact your Yaskawa representative or the nearest Yaskawa sales office and provide the manual number shown on the front cover.

## DANGER

**Heed the safety messages in this manual.**

Failure to comply will result in death or serious injury.

The operating company is responsible for any injuries or equipment damage resulting from failure to heed the warnings in this manual.

### NOTICE

**Do not expose the drive to halogen group disinfectants.**

Failure to comply may cause damage to the electrical components in the option card.

Do not pack the drive in wooden materials that have been fumigated or sterilized.

Do not sterilize the entire package after the product is packed.

**Do not modify the drive circuitry.**

Failure to comply could result in damage to the drive and will void warranty.

YASKAWA is not responsible for any modification of the product made by the user. This product must not be modified.



# 2 Product Overview

### ◆ About This Product

PROFIBUS option card (Model: SI-P3) is an open digital communication system supporting a wide range of fast, time-critical applications.

PROFIBUS-DP (Decentral Periphery) is one of the three PROFIBUS variants. DP is dedicated to fast data communication between systems and peripherals at a field level. This PROFIBUS-DP Option connects a drive to a field network using the PROFIBUS-DP protocol.

PROFIBUS-DP is included into the European Fieldbus Standard EN 50170.

The network is primarily used in process and factory automation.

By installing the PROFIBUS-DP Option to a drive, it is possible to do the following from a PROFIBUS-DP master device:

- operate the drive
- monitor the operation status of the drive
- change parameter settings

## 3 Receiving





### 3 Receiving

Please perform the following tasks after receiving the PROFIBUS-DP Option:

- Inspect the PROFIBUS-DP Option for damage.  
If the PROFIBUS-DP Option appears damaged upon receipt, contact the shipper immediately.
- Verify receipt of the correct model by checking the information on the PCB (see [Figure 1](#)).
- If you have received the wrong model or the PROFIBUS-DP Option does not function properly, contact your supplier.

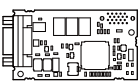
#### ◆ Contents and Packaging

Table 1 Contents of Package

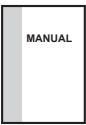
Description:	Option Card	Ground Cable	Screws (M3)	LED Label	Installation Manual (This Book)
					
Quantity:	1	1	3	1	1

#### ◆ Tool Requirements

A Phillips screwdriver (M3) metric or (#1, #2) U.S. standard size is required to install the PROFIBUS-DP Option.

**Note:** Tools required to prepare PROFIBUS cables for wiring are not listed in this manual.

## 4 PROFIBUS-DP Option Components

### ◆ PROFIBUS-DP Option

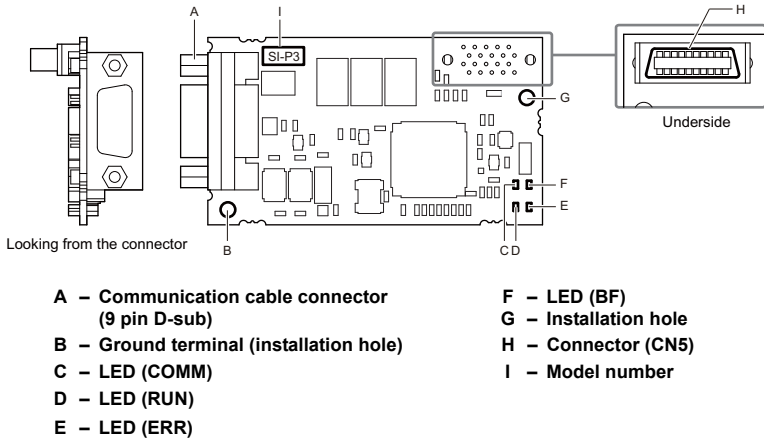

**Figure 1 Option Card**

**Note:** For details on the LEDs, Refer to [PROFIBUS-DP Option LED Display on page 12](#).

## 4 PROFIBUS-DP Option Components

### ◆ Communication connector

The drive has a 9 pin D-sub connector for installing the option card. Once installed, the drive can connect to a PROFIBUS network.

**Table 2 Communication connector (9-pin D-SUB)**

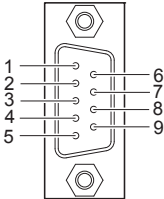
PROFIBUS Connector	Pin	Signal	Description
Bottom View 	1	Shield	Connected to the metal-shell (no direct FG-connection)
	2	–	–
	3	RxD/TxD-P	Receive/Transmit data; line B (red)
	4	CNTR-P	Control signal for repeaters (direction control)
	5	DGND	Data ground (reference voltage to VP)
	6	VP	Power supply output for bus termination (for terminal resistor)
	7	–	–
	8	RxD/TxD-N	Receive/Transmit data; line A (green)
	9	–	–

### ◆ PROFIBUS-DP Option LED Display

**Table 3 LED Display**

LED	Display		Communication Status	Meaning
	Color	Status		
RUN (Power)	Green	ON	Power is on	Power is being properly supplied to SI-P3, and SI-P3 has completed its hardware self-diagnostics check
		OFF	Power is off	<ul style="list-style-type: none"> <li>The drive has no power supply</li> <li>SI-P3 and drive are not connected properly and/or there is no power supplied to the SI-P3</li> <li>An internal, self-diagnostic error occurred in SI-P3.</li> </ul>
ERR (Option Error)	Red	ON	SI-P3 error	Self-diagnostics error occurred in the SI-P3
		Flashing	Drive connection error	Connection error between SI-P3 and drive. This includes node address setting errors to parameter F6-30 on the drive side
		OFF	Normal operation	Drive and SI-P3 are properly connected.

## 4 PROFIBUS-DP Option Components

LED	Display		Communication Status	Meaning
	Color	Status		
COMM (Communication Status)	Green	ON	Communication connected	Normal send/receive between SI-P3 and PROFIBUS-DP master
		OFF	No data exchange	There is a problem establishing communication between SI-P3 and the PROFIBUS-DP master
BF (PROFIBUS-DP Error)	Red	ON	Waiting for communication procedure setting	Communication-related parameters are being set or initialized by the PROFIBUS-DP master.
		Flashing	Communication setting error	Communication parameter error from PROFIBUS-DP master
		OFF	Normal operation	LED shuts off once the PROFIBUS-DP master is finished setting communication-related parameters.

**Table 4 Understanding LED Display**

LED				Communication Status	Possible Cause	Solution
RUN	ERR	COMM	BF			
×	×	×	×	No power.	<ul style="list-style-type: none"> <li>The drive has no power.</li> <li>SI-P3 is not properly connected to the drive, and therefore is not receiving enough power.</li> </ul>	<ul style="list-style-type: none"> <li>Check all wiring to the drive, then turn the power on.</li> <li>Shut the drive off and see if the PROFIBUS-DP Option is connected properly. Turn the power back on again.</li> </ul>
○	×	×	×	<ul style="list-style-type: none"> <li>Checking connection with the drive</li> <li>Waiting for data from the master.</li> </ul>	<ul style="list-style-type: none"> <li>SI-P3 is reading the node address or parameter configuration</li> <li>Waiting for initial input data from master device.</li> </ul>	–
×	○	×	×	SI-P3 Self-diagnostics error	The PROFIBUS-DP Option is damaged.	<ul style="list-style-type: none"> <li>Cycle power to the drive. If the LED status does not change, replace the PROFIBUS-DP Option.</li> </ul>

## 4 PROFIBUS-DP Option Components

LED				Communication Status	Possible Cause	Solution
RUN	ERR	COMM	BF			
×	□	×	×	Problem connecting to the drive.	<ul style="list-style-type: none"> <li>• Problem initializing the drive and SI-P3</li> <li>• Incorrect node address.</li> </ul>	<ul style="list-style-type: none"> <li>• Cycle power to the drive. If the LED status does not change, replace the PROFIBUS-DP Option</li> <li>• Check the node address setting in the drive (parameter F6-10).</li> </ul>
○	×	×	○	Waiting for data from the master device.	Waiting for data from the master device (Set_Param_Message or Chk_Cfg_Message).	<ul style="list-style-type: none"> <li>• Check the network settings in the master</li> <li>• Make sure the master device is operating normally</li> <li>• Check the terminal resistance settings on the data line</li> <li>• Look for any problems with the data line, or if the connector</li> <li>• See if the data line connected properly to the drive's main circuit.</li> </ul>
○	×	×	□	Data is incorrect or PROFIBUS-DP Option timed out waiting for data.	The communication procedure in the master is set incorrectly.	<ul style="list-style-type: none"> <li>• Check the communication procedure settings in the master.</li> </ul>
○	×	○	×	Sending or receiving data.	–	–

○: On / □: Flashing / ×: Off

### ◆ Setting Node Address

Set drive parameter F6-30 to a node address (Range 0 to 125) unique to the network.

## 5 Installation Procedure

### ◆ Section Safety

#### DANGER

##### **Electrical Shock Hazard**

**Power to the drive must be shut off when installing this option card.**

Even though the power has been shut off, voltage still remains in the drive's DC bus. Wait before removing the front cover once the drive has been turned off.

The CHARGE light on the drive will go out after voltage in the DC bus drops below 50 V, at which point it is safe to remove the front cover.

Due to the risk of electric shock, be sure that all LEDs have gone out and that the DC bus voltage has reached a safe level prior to performing any work on the drive.

#### WARNING

##### **Electrical Shock Hazard**

**Do not remove the front cover of the drive while the power is on.**

Failure to comply could result in death or serious injury.

The diagrams in this section may include option cards and drives without covers or safety shields to show details. Be sure to reinstall covers or shields before operating any devices. The option board should be used according to the instructions described in this manual.

**Do not allow unqualified personnel to use equipment.**

Failure to comply could result in death or serious injury.

Maintenance, inspection, and replacement of parts must be performed only by authorized personnel familiar with installation, adjustment, and maintenance of this product.

## 5 Installation Procedure

---

### **WARNING**

**Do not touch the option card while there is power flowing through the drive.**

Failure to comply could result in death or serious injury.

**Do not use damaged wires, place excessive stress on wiring, or damage the wire insulation.**

Failure to comply could result in death or serious injury.

### **NOTICE**

#### **Damage to Equipment**

**Observe proper electrostatic discharge procedures (ESD) when handling the option card, drive, and circuit boards.**

Failure to comply may result in ESD damage to circuitry.

**Never shut the power off while the drive is outputting voltage.**

Failure to comply may cause the application to operate incorrectly or damage the drive.

**Do not operate damaged equipment.**

Failure to comply may cause further damage to the equipment.

Do not connect or operate any equipment with visible damage or missing parts.

**Tighten all terminal screws to the specified tightening torque.**

Loose electrical connections could result in death or serious injury by fire due to overheating of electrical connections.

**Do not use unshielded cable for control wiring.**

Failure to comply may cause electrical interference resulting in poor system performance.

Use shielded twisted-pair wires and ground the shield to the ground terminal of the drive.



### NOTICE

**Properly connect all pins and connectors.**

Failure to comply may prevent proper operation and possibly damage equipment.

**Check wiring to ensure that all connections are correct after installing the option card and connecting any other devices.**

Failure to comply may result in damage to the option card.

### ◆ Connection Diagram

The PROFIBUS-DP Option must be connected to the network using a 9 pin D-sub connector like shown in [Figure 2](#).

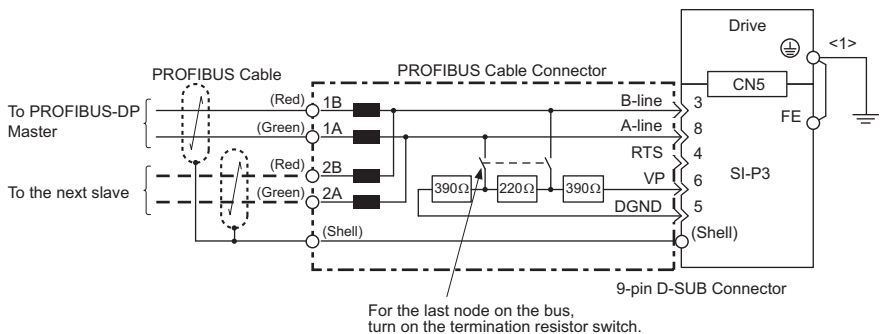

<1> The FE terminal on the PROFIBUS-DP Option is fitted with a ground cable that should be connected to the ground terminal on the drive.

**Figure 2 Connection Diagram**

## 5 Installation Procedure

### ■ PROFIBUS-DP Termination

Because the option card does not have a terminal resistor, terminal resistance must be set using a switch on the 9 pin D-sub connector. Make sure that only the D-sub connector for the final drive in the network is set for terminal resistance. If any other drive on the network is set for terminal resistance, communication problems may occur.

Most 9 pin D-sub connectors have a function for disconnecting the output side of the cable. Use only the input side cable entry when connecting both ends of the network. If the connector is reversed, then communication will not be possible between devices. Most connectors have arrows indicating the input and output sides.

Terminating resistors without inductors as shown in [Figure 3](#) can only be used for baud rates below 1.5 Mbps. 1.5 Mbps and higher baud rates require termination with resistors and inductors like shown in.

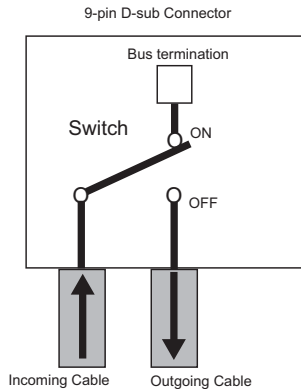

**Figure 3 PROFIBUS Cable Connection with Termination Resistors**

<b>Bus termination ON</b> = incoming and outgoing cables not connected.
<b>Bus termination OFF</b> = incoming and outgoing cables connected.

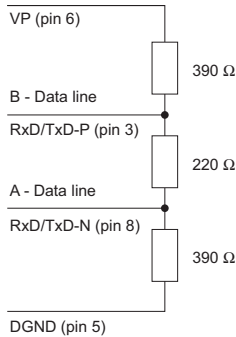

**Figure 4 Cable Termination of the PROFIBUS-DP Option Cable to EN50170  
(pin numbers for a 9-pin D-sub connector)**

### ◆ Prior to Installing the Option Card

Prior to installing the PROFIBUS-DP Option, wire the drive and make necessary connections to the drive terminals. For more information on wiring and connecting the drive, refer to the installation manual for the drive the PROFIBUS-DP option card is connected to. Verify that the drive runs normally without the option installed.

## 5 Installation Procedure

### ◆ Installing the Option Card

Insert the option card in the CN5-A connectors located on the drive's control board. See the drive manual for directions on removing the front cover.

1. Shut off power to the drive, wait the appropriate amount of time for voltage to dissipate, then remove the operator and front cover.
2. Insert the CN5 connector on the option card into the matching CN5 connector on the drive, then fasten it into place using one of the screws included with the option card. Connect one of the lead lines using one of the screws to the ground terminal. Three separate lead lines have been included with the option card to connect to three separate ports. Use the lead line with the length appropriate for the distance of the port.

**Note:** There are only two screw holes on the drive for ground terminals. If three option cards are connected, two of the lead lines will need to share the same ground terminal.

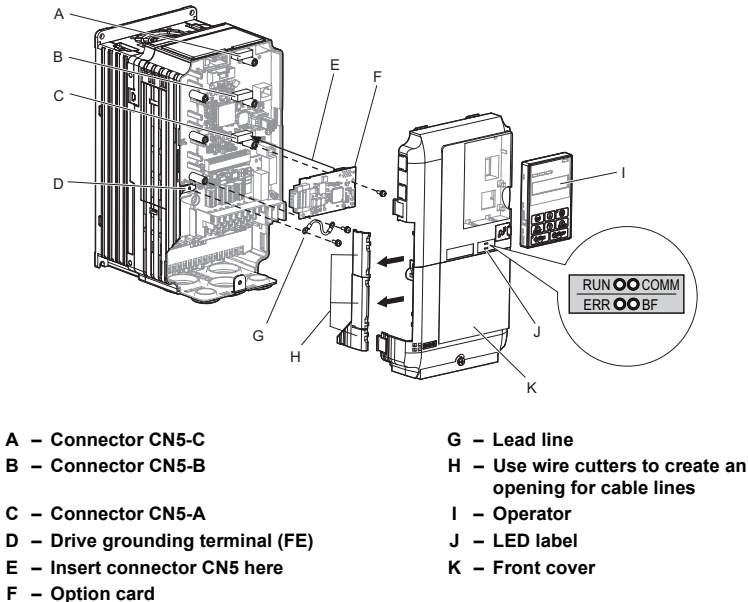
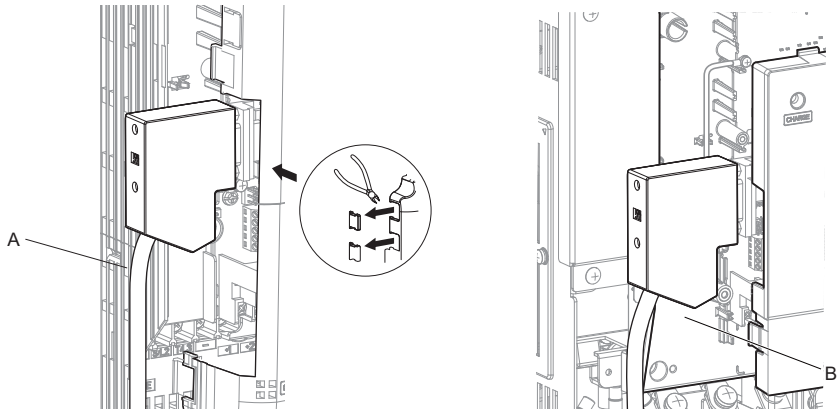

Figure 5 Installing the Option Card

3. Wire the option card to the communication cable connector on the option card.  
For exposed cables in drives 2A004 to 0069, 4A0002 to 0044, use a pair of wire cutters to create an opening on the left side of the front cover that allows wiring to pass through. Sharp edges along the opening that was created should be smoothed down with a file or sand paper so prevent any damage to the wires.  
Drives 2A0081 to 0021, 4A0058 to 0165 have enough space to keep all wiring inside the unit.



**A – Opening for cable lines  
(2A0004 to 0069, 4A0002 to 0044)**

**B – Space for wiring  
(2A0081 to 0211, 4A0058 to 0165)**

**Figure 6 Wiring space**

4. Place the front cover back onto the drive as it was before.

**Note:** 1. Take care when wiring the option card so that the front cover easily fits back onto the drive.  
2. Install Cable Cover option to maintain the drive Enclosure Type.

5. Attach the LED label packaged with the option card as shown in [Figure 5](#).

## 5 Installation Procedure

---

### ◆ Communication Cable Specifications

To ensure proper performance, Yaskawa recommends using PROFIBUS-DP-dedicated cables that fulfill the specifications in [Table 5](#). For more information on cables, refer to the PROFIBUS-DP website at <http://www.profibus.com>.

#### ■ Cable Requirements

**Table 5 Communication Cable Requirements**

Condition	Specifications
Impedance	135 to 165 $\Omega$ at a frequency of (3 to 20 MHz)
Capacity	30 pF/m maximum
Loop Resistance	110 $\Omega$ /km maximum
Core Cross-Section	0.34 mm <sup>2</sup> minimum
Core Diameter	0.64 mm minimum

#### ■ Cable Length

Communication speed determines maximum permissible cable length. [Table 6](#) shows the specifications for Type A bus cables.

**Table 6 Cable Length**

Communication speed (kbps)	Distance per segment (m)	Communication speed (kbps)	Distance per segment (m)
9.6	1200	500	400
19.2	1200	1500	200
45.45	1200	3000	100
93.75	1200	6000	100
187.5	1000	12000	100

### ◆ GSD Files

For easy network implementation of drives equipped with an SI-P3, a GSD file can be obtained from:

U.S.: <http://www.yaskawa.com>

Europe: <http://www.yaskawa.eu.com>

Japan: <http://www.e-mechatronics.com>

Other areas: contact a Yaskawa representative

## 6 PROFIBUS-DP Option Drive Parameters

Confirm the proper setting of all parameters in *Table 7* before starting network parameters.

**Table 7 Parameter Settings**

No.	Name	Description	Default
b1-01 </>	Frequency Reference Selection	Selects the frequency reference input source 0: Operator - Digital preset speed d1-01 to d1-17 1: Terminals - Analog input terminal A1 or A2 2: MEMOBUS/Modbus communications 3: Option card 4: Pulse Input (Terminal RP)	1
b1-02 </>	Run Command Selection	Selects the run command input source 0: Digital Operator - RUN and STOP keys 1: Digital input terminals S1 to S7 2: MEMOBUS/Modbus communications 3: Option card	1
F6-01	Operation Selection after Communications Error	Determines drive response when a bUS error is detected during communications with the PROFIBUS-DP Option 0: Ramp to Stop 1: Coast to Stop 2: Fast-Stop 3: Alarm Only </>	1
F6-02	External Fault Detection Conditions (EF0)	Sets the condition for external fault detection (EF0) 0: Always detected 1: Detected only during operation	0
F6-03	Stopping Method for External Fault from Communication Option Board	Determines drive response for external fault input (EF0) detection during PROFIBUS communication 0: Ramp to Stop 1: Coast to Stop 2: Fast-Stop 3: Alarm Only </>	1
F6-06 </>	Torque Reference/Torque Limit selection from Communications Option	0: Torque reference/torque limit via network communications are disabled. 1: Torque reference/torque limit via network communications are enabled. </>	0
F6-07	NetRef/ComRef Selection Function	0: Multi-step speed reference disabled (F7 mode) 1: Multi-step speed reference allowed (V7 mode)	1

## 6 PROFIBUS-DP Option Drive Parameters

No.	Name	Description	Default
F6-08	Reset Communication Related Parameters	Determines which communication-related parameters are set back to their original default values when the drive is initialized. 0: Do not reset F6-□□ and F7-□□ parameters when the drive is initialized using parameter A1-03. 1: Rest F6-□□ and F7-□□ parameters when the drive is initialized using parameter A1-03. <b>Note:</b> Setting this parameter does not affect communication-related parameters. Setting this parameter only determines if communication-related parameters (F6-□□ and F7-□□) are also reset when A1-03 is used to initialize the drive.	0
F6-30 <> <>	Node Address	0 to 125	0
F6-31	Clear Mode Selection	Selects the action to take when a "Clear Mode" command is received 0: Resets back to 0 1: Maintains the previous value	0
F6-32 <>	PROFIBUS Map Selection	0: PPO Type 1: Conventional	0
F6-33 <>	IND Data Size Selection	0: word 1: byte	0

- <1> To start and stop the drive through the PROFIBUS-DP network, set b1-02 to "3". To control the frequency reference of the drive via the PROFIBUS-DP network, set b1-01 to "3".
- <2> If F6-03 is set to 3, then the drive will continue to operate when an EF0 fault is detected. Take proper safety measures, such as installing an emergency stop switch.
- <3> Enabled in CLV, AOLV/PM, and CLV/PM control modes (A1-02 = 3, 6, or 7). When enabled, d5-01 determines whether the value is read as the torque limit value (d5-01 = 0) or read as the torque reference value (d5-01 = 1). In Closed Loop Vector for PM motors, this value is read as the torque limit.
- <4> Default setting specifies that the torque reference or torque limit is to be provided via network communications (F6-06 = 1). The motor may not rotate if no torque reference or torque limit is supplied from the PLC.
- <5> All node addresses must be unique. Node addresses 0, 1, and 2 are typically reserved for control, maintenance, and diagnostic equipment. The ERR light will illuminate when 0 or greater than 125 is entered.
- <6> Power must be cycled in order for any setting changes to take affect.



## 7 PROFIBUS-DP Option Data and I/O Maps

### ◆ Conventional Formats

The configuration tool of PROFIBUS-DP master sets the input and output data length of SI-P3 from Extended Data 1 (32 bytes), Extended Data 2 (12 bytes), and Basic Data (6 bytes).

Conventional formats have two message types: High-speed I/O Data and MEMOBUS/Modbus message.

Set parameter F6-32 to “1” to use conventional formats.

### ■ High-Speed I/O Data

High-speed I/O data is directly transferred to or from the drive and can control the drive. For example, when the drive is set for PROFIBUS-DP communications, the drive Run/Stop and Frequency Reference commands are typically transferred to the drive within 2 ms after being received by the option.

### ■ MEMOBUS/Modbus Message

MEMOBUS/Modbus message data is transferred to the drive using MEMOBUS/Modbus messages. All drive parameters and data can be accessed through MEMOBUS/Modbus. Because the data in this message type is transferred to the drive after the SI-P3 receives and edits it, more time is required to return the data to the master. The master must synchronize the timing of sending and receiving the data by handshaking.

### ■ Memory Maps

The following memory maps show the I/O data bytes.

### ■ Basic and Extended Register Maps

	Basic Data (6 bytes)	Extended Data 1 (32 bytes)	Extended Data 2 (12 bytes)
High-speed I/O Data	Bytes 0 to 5	Bytes 0 to 15	Bytes 0 to 3
MEMOBUS/Modbus Data	–	Bytes 16 to 31	Bytes 4 to 11

## 7 PROFIBUS-DP Option Data and I/O Maps

**Table 8 Basic Data Register Map Detail**

Output (Master Device → Drive)		Input (Drive → Master Device)	
Byte	Description	Byte	Description
0	Operation Command High Byte	0	Drive Status High Byte
1	Operation Command Low Byte	1	Drive Status Low Byte
2	Frequency Reference High Byte	2	Motor Speed High Byte <3>
3	Frequency Reference Low Byte	3	Motor Speed Low Byte <3>
4	Torque Reference/Torque Limit High Byte <1> <2>	4	Output Current High Byte <4>
5	Torque Reference/Torque Limit Low Byte <1> <2>	5	Output Current High Byte <4>

- <1> Enabled in CLV, AOLV/PM, and CLV/PM control modes (A1-02 = 3, 6, or 7).
- <2> Set when network communication is designated as the source of the torque limit and torque reference (F6-06 = 1). When enabled, d5-01 determines whether the value is read as the torque limit value (d5-01 = 0) or read as the torque reference value (d5-01 = 1). In Closed Loop Vector for PM motors, this value is read as the torque limit.
- <3> Unit depends on the setting of o1-03 (Digital Operator Display Scaling). When the drive is operating in the V/f Control mode or Open loop vector for PM mode, the drive's output frequency becomes the input data.
- <4> Data is displayed in units of either 0.01 A for drives 7.5 kW and smaller, or in units of 0.1 A for drives 11 kW and larger. This is the same regardless of whether the drive is set for Normal Duty or Heavy Duty operation.

**Table 9 Extended Data 1 Register Map**

Output (Master Device → Drive)		Input (Drive → Master Device)	
Byte	Description	Byte	Description
0	Operation Command High Byte	0	Drive Status High Byte
1	Operation Command Low Byte	1	Drive Status Low Byte
2	Frequency Reference High Byte	2	Motor Speed High Byte <5>
3	Frequency Reference Low Byte	3	Motor Speed Low Byte <5>
4	Torque Reference High Byte <1> <2>	4	Torque Reference Monitor High Byte <6>
5	Torque Reference Low Byte <1> <2>	5	Torque Reference Monitor Low Byte <6>
6	Torque Compensation High Byte <1>	6	Speed Detection PG Pulse Count 1 High Byte
7	Torque Compensation Low Byte <1>	7	Speed Detection PG Pulse Count 1 Low Byte
8	Reserved	8	Frequency Reference High Byte
9		9	Frequency Reference Low Byte
10	Analog Output Channel 1 High Byte <3>	10	Output Frequency High Byte
11	Analog Output Channel 1 Low Byte <3>	11	Output Frequency Low Byte
12	Analog Output Channel 2 High Byte <3>	12	Output Current High Byte <7>
13	Analog Output Channel 2 Low Byte <3>	13	Output Current Low Byte <7>

## 7 PROFIBUS-DP Option Data and I/O Maps

Output (Master Device → Drive)		Input (Drive → Master Device)	
Byte	Description	Byte	Description
14	Digital Output High Byte <4>	14	Analog Input Channel 1 High Byte
15	Digital Output Low Byte <4>	15	Analog Input Channel 1 Low Byte
16	MEMOBUS/Modbus Function Code	16	MEMOBUS/Modbus Function Code
17	MEMOBUS/Modbus Starting Register Address High Byte	17	MEMOBUS/Modbus Starting Register Address High Byte
18	MEMOBUS/Modbus Starting Register Address Low Byte	18	MEMOBUS/Modbus Starting Register Address Low Byte
19	MEMOBUS/Modbus Number of Data	19	MEMOBUS/Modbus Number of Data
20	MEMOBUS/Modbus Data 1 High Byte	20	MEMOBUS/Modbus Data 1 High Byte
21	MEMOBUS/Modbus Data 1 Low Byte	21	MEMOBUS/Modbus Data 1 Low Byte
22	MEMOBUS/Modbus Data 2 High Byte	22	MEMOBUS/Modbus Data 2 High Byte
23	MEMOBUS/Modbus Data 2 Low Byte	23	MEMOBUS/Modbus Data 2 Low Byte
24	MEMOBUS/Modbus Data 3 High Byte	24	MEMOBUS/Modbus Data 3 High Byte
25	MEMOBUS/Modbus Data 3 Low Byte	25	MEMOBUS/Modbus Data 3 Low Byte
26	MEMOBUS/Modbus Data 4 High Byte	26	MEMOBUS/Modbus Data 4 High Byte
27	MEMOBUS/Modbus Data 4 Low Byte	27	MEMOBUS/Modbus Data 4 Low Byte
28	Reserved	28	Reserved
29		29	
30		30	
31	Handshaking Register	31	Handshake Register

- <1> Enabled in CLV, AOLV/PM, and CLV/PM control modes (A1-02 = 3, 6, or 7).
- <2> Set when network communication is designated as the source of the torque limit and torque reference (F6-06 = 1). When enabled, d5-01 determines whether the value is read as the torque limit value (d5-01 = 0) or read as the torque reference value (d5-01 = 1). In Closed Loop Vector for PM motors, this value is read as the torque limit.
- <3> To select drive analog output channel for communications, set H4-01 (Multi-Function Analog Output Terminal FM) and H4-04 (Multi-Function Analog Output Terminal AM) to 000 (through-mode).
- <4> Drive digital output ON/OFF during communications, set H2-01 (Terminal M1, M2 and MC Function Selection (relay)), H2-02 (Terminal P1 Function Selection (open-collector)), and H2-03 (Terminal P2 Function Selection (open-collector)) to F (through-mode).
- <5> Unit depends on the setting of o1-03 (Digital Operator Display Scaling). Input data is 0 when the drive is set for V/f Control or Open loop vector for PM mode.
- <6> Not possible when using V/f control, V/f with PG, or Open loop vector for PM motors (A1-02 = 0, 1, or 5).
- <7> Data is displayed in units of either 0.01 A for drives 7.5 kW and smaller, or in units of 0.1 A for drives 11 kW and larger. This is the same regardless of whether the drive is set for Normal Duty or Heavy Duty operation.

**Table 10 Extended Data 2 Register Map**

Output (Master Device → Drive)		Input (Drive → Master Device)	
Byte	Description	Byte	Description
0	Operation Command High Byte	0	Drive Status High Byte
1	Operation Command Low Byte	1	Drive Status Low Byte
2	Frequency Reference High Byte	2	Motor Speed High Byte </>
3	Frequency Reference Low Byte	3	Motor Speed Low Byte </>
4	MEMOBUS/Modbus Function Code	4	MEMOBUS/Modbus Function Code
5	MEMOBUS/Modbus Starting Register Address High Byte	5	MEMOBUS/Modbus Starting Register Address High Byte
6	MEMOBUS/Modbus Starting Register Address Low Byte	6	MEMOBUS/Modbus Starting Register Address Low Byte
7	MEMOBUS/Modbus Data Length	7	MEMOBUS/Modbus Data Length
8	MEMOBUS/Modbus Data 1 High Byte	8	MEMOBUS/Modbus Data 1 High Byte
9	MEMOBUS/Modbus Data 1 Low Byte	9	MEMOBUS/Modbus Data 1 Low Byte
10	Reserved	10	Reserved
11	Handshaking Register	11	Handshake Register

</> Unit depends on the setting of o1-03 (Digital Operator Display Scaling). When the drive is operating in the V/f Control mode or Open loop vector for PM mode, the drive's output frequency becomes the input data.

### ◆ Supported Parameter Process Data Object (PPO) Type Formats

Set drive parameter F6-32 = “0” to use PPO type formats. The PPO is defined for cyclic data transfer, allowing the master and the slave to exchange process data (PZD) and parameters. Refer to the PROFIBUS specification for more information on PPO types 1~5.

SI-P3 supports five possible PPO type formats:

PPO type 1 (8 octets PKW + 4 octets PZD)
PPO type 2 (8 octets PKW + 12 octets PZD)
PPO type 3 (4 octets PZD)
PPO type 4 (12 octets PZD)
PPO type 5 (8 octets PKW + 20 octets PZD)

All PPO Types have the registers STW, ZSW, HSW, and HIW. These registers are not mapped directly to drive registers.



# 8 Troubleshooting

### ◆ Drive-Side Error Codes

Drive-side error codes appear on the drive operator. Causes of the errors and corrective actions are listed in [Table 11](#). For additional error codes that may appear on the operator screen, refer to the Technical Manual for the drive.

#### ■ Faults

bUS (PROFIBUS-DP Option Communication Error) and EF0 (External Fault Input from the PROFIBUS-DP Option) may appear as an alarm or a fault. When a fault occurs, the operator remains lit. When an alarm occurs, the operator flashes and the “ALM” light illuminates

If communication stops while the drive is running, check the following items to resolve the fault:

- Is the PROFIBUS-DP Option properly installed?
- Is the communication line properly connected to the PROFIBUS-DP Option? Is it loose?
- Is the controller program working? Has the controller CPU stopped?
- Did a momentary power loss interrupt communications?

**Table 11 Fault Display and Possible Solutions**

Operator Display		Fault Name
<i>bUS</i>	bUS	PROFIBUS-DP Option Communication Error
		After establishing initial communication, the connection was lost. Only detected when the run command or frequency reference is assigned to the option (b1-03 = 3 or b1-02 = 3).
Cause		Possible Solution
Master controller (PLC) has stopped communicating.		Check for faulty wiring. <ul style="list-style-type: none"> <li>• Correct any wiring problems.</li> </ul>
Communication cable is not connected properly.		
A data error occurred due to noise.		Check the various options available to minimize the effects of noise. <ul style="list-style-type: none"> <li>• Take steps to counteract noise in the control circuit wiring, main circuit lines, and ground wiring.</li> <li>• If a magnetic contactor is identified as a source of noise, install a surge absorber to the contactor coil.</li> <li>• Use cables recommended by Yaskawa, or another type of shielded line. Ground the shield on the controller side and on the PROFIBUS-DP Option side.</li> </ul>
PROFIBUS-DP Option is damaged.		<ul style="list-style-type: none"> <li>• If there are no problems with the wiring and the error continues to occur, replace the PROFIBUS-DP Option.</li> </ul>

Operator Display		Fault Name
	EF0	External Fault Input from PROFIBUS-DP Option
		The alarm function for an external device has been triggered.
Cause		Possible Solution
An external fault is being sent from the upper controller (PLC).		<ul style="list-style-type: none"> <li>Remove the cause of the external fault.</li> <li>Reset the external fault input from the upper controller (PLC) device.</li> </ul>
Problem with the upper controller (PLC) program.		<ul style="list-style-type: none"> <li>Check the program used by the upper controller (PLC) and make the appropriate corrections.</li> </ul>

Operator Display		Fault Name
	oFA00	PROFIBUS-DP Option Fault (Port A)
		PROFIBUS-DP Option is not properly connected.
Cause		Possible Solution
Non-compatible option connected to the drive.		<ul style="list-style-type: none"> <li>Connect an option that is compatible with the drive.</li> </ul>

Operator Display		Fault Name
	oFA01	PROFIBUS-DP Option Fault (Port A)
		PROFIBUS-DP Option is not properly connected.
Cause		Possible Solution
Problem with the connectors between the drive and PROFIBUS-DP Option.		<ul style="list-style-type: none"> <li>Turn the power off and check the connectors between the drive and PROFIBUS-DP Option.</li> </ul>

Operator Display		Fault Name
	oFA30 to oFA43	PROFIBUS-DP Option Fault (port A)
		Communication ID error
Cause		Possible Solution
PROFIBUS-DP Option hardware fault		⇒ Replace the PROFIBUS-DP Option. Contact Yaskawa for assistance.

## 8 Troubleshooting

Operator Display		Fault Name
oFb00	oFb00	PROFIBUS-DP Option Fault (CN5-B)
		Non-compatible option card is connected.
Cause		Possible Solution
Non-compatible option connected to the drive.		⇒ Connect the correct option card to CN5-A.

Operator Display		Fault Name
oFb02	oFb02	PROFIBUS-DP Option Fault (CN5-B)
		Two of the same option cards are connected at the same time.
Cause		Possible Solution
Option cards AI-A3 or DI-A3 were connected to the CN5-B port while an option card was already connected to CN5-A.		⇒ Only one type of option input card AI-A3 or DI-A3 can be connected to the drive. Only this option card for PROFIBUS-DP can be connected to CN5-A.

Operator Display		Fault Name
oFc00	oFc00	PROFIBUS-DP Option Fault (CN5-C)
		Non-compatible option card is connected.
Cause		Possible Solution
Non-compatible option connected to the drive.		⇒ Connect the correct option card to CN5-A.

Operator Display		Fault Name
oFc02	oFc02	PROFIBUS-DP Option Fault (CN5-C)
		Two of the same option cards are connected at the same time.
Cause		Possible Solution
Option cards AI-A3 or DI-A3 were connected to the CN5-C port while an option card was already connected to CN5-A.		⇒ Only one type of option input card AI-A3 or DI-A3 can be connected to the drive. Only this option card for PROFIBUS-DP can be connected to CN5-A.



### ■ Minor Faults and Alarms

**Table 12 Alarm Display**

Operator Display		Minor Fault Name	
$\overline{bb}$	bb	Baseblock	
		Data format and setting contents do not match.	
Cause		Possible Solution	Minor Fault (H2-□□ = 10)
The drive output is disabled. "bb" will be displayed on the operator when the drive is set for control by PROFIBUS-DP and: <ul style="list-style-type: none"> <li>• a conventional data format is used and the operation command bit F is set to 1.</li> <li>• a PPO type data format is used the the control word (STW) bit 3 is set to 0.</li> </ul>		Set either of the bits depending on which data format is used.	No output

Operator Display		Minor Fault Name	
$\overline{CALL}$	CALL	Serial Communication Transmission Error	
		Communication has not yet been established.	
Cause		Possible Solution	Minor Fault (H2-□□ = 10)
Communication wiring is faulty, there is a short circuit, or something is not connected properly.		Check for wiring errors. ⇒ Correct the wiring. ⇒ Remove and ground shorts and reconnect loose wires.	YES
Programming error on the master side		⇒ Check communications at start-up and correct programming errors.	
Communication circuitry is damaged.		Perform a self-diagnostics check. ⇒ Replace the drive if the fault continues to occur.	

# 9 Specifications

### ◆ Specifications

**Table 13 Option Card Specifications**

Items	Specifications
Model	SI-P3
PROFIBUS-DP Data	PROFIBUS DP-V0, V1 PPO TYPE: 1~5 (No. 3.072, Profile for Variable Speed Drives) Extended data 1 High-speed I/O data (inputs: 16 bytes, outputs: 16 bytes) MEMOBUS/Modbus message (inputs: 16 bytes, outputs: 16 bytes) Extended data 2 High-speed I/O data (inputs: 4 bytes, outputs: 4 bytes) MEMOBUS/Modbus message (inputs: 8 bytes, outputs: 8 bytes) Basic data High-speed I/O data (inputs: 6 bytes, outputs: 6 bytes)
Connector	9-pin D-sub connector (#4/40 UNC thread)
Communications Speed	9.6 kbps to 12 Mbps
Ambient Temperature	-10 °C to +50 °C
Humidity	up to 95% RH (no condensation)
Storage Temperature	-20 °C to +60 °C (allowed for short-term transport of the product)
Area of Use	Indoor (free of corrosive gas, airborne particles, etc.)
Altitude	up to 1000 m

### ◆ Revision History

The revision dates and the numbers of the revised manuals appear on the bottom of the back cover.

MANUAL NO. TOBP C730600 42A

Published in Japan August 2008 08-8

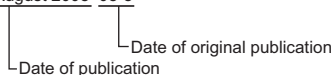

Date of Printing	Revision Number	Section	Revised Content
August 2008	—	—	First Edition

# YASKAWA AC Drive-Option Card

# PROFIBUS-DP

## Installation Manual

---

### **IRUMA BUSINESS CENTER (SOLUTION CENTER)**

480, Kamifuji-sawa, Iruma, Saitama 358-8555, Japan  
Phone 81-4-2962-5696 Fax 81-4-2962-6138

### **YASKAWA ELECTRIC AMERICA, INC.**

2121 Norman Drive South, Waukegan, IL 60085, U.S.A.  
Phone 1-847-887-7000 Fax 1-847-887-7370

### **YASKAWA ELÉTRICO DO BRASIL LTDA.**

Avenida Fagundes Filho, 620 São Paulo-SP CEP 04304-000, Brazil  
Phone 55-11-3585-1100 Fax 55-11-5581-8795

### **YASKAWA ELECTRIC EUROPE GmbH**

Hauptstraße 185, 65760 Eschborn, Germany  
Phone 49-6196-569-300 Fax 49-6196-569-398

### **YASKAWA ELECTRIC UK LTD.**

1 Hunt Hill Orchardton Woods Cumbernauld, G68 9LF, United Kingdom  
Phone 44-1236-735000 Fax 44-1236-458182

### **YASKAWA ELECTRIC KOREA CORPORATION**

7F, Doore Bldg. 24, Yeoido-dong, Youngdungpo-Ku, Seoul 150-877, Korea  
Phone 82-2-784-7844 Fax 82-2-784-8495

### **YASKAWA ELECTRIC (SINGAPORE) PTE. LTD.**

151 Lorong Chuan, #04-01, New Tech Park 556741, Singapore  
Phone 65-6282-3003 Fax 65-6289-3003

### **YASKAWA ELECTRIC (SHANGHAI) CO., LTD.**

No.18 Xizang Zhong Road, Room 1702-1707, Harbour Ring Plaza Shanghai 200001, China  
Phone 86-21-5385-2200 Fax 86-21-5385-3299

### **YASKAWA ELECTRIC (SHANGHAI) CO., LTD. BEIJING OFFICE**

Room 1011A, Tower W3 Oriental Plaza, No.1 East Chang An Ave.,  
Dong Cheng District, Beijing 100738, China  
Phone 86-10-8518-4086 Fax 86-10-8518-4082

### **YASKAWA ELECTRIC TAIWAN CORPORATION**

9F, 16, Nanking E. Rd., Sec. 3, Taipei, Taiwan  
Phone 886-2-2502-5003 Fax 886-2-2505-1280



YASKAWA

YASKAWA ELECTRIC CORPORATION

In the event that the end user of this product is to be the military and said product is to be employed in any weapons systems or the manufacture thereof, the export will fall under the relevant regulations as stipulated in the Foreign Exchange and Foreign Trade Regulations. Therefore, be sure to follow all procedures and submit all relevant documentation according to any and all rules, regulations and laws that may apply. Specifications are subject to change without notice for ongoing product modifications and improvements.

© 2008 YASKAWA ELECTRIC CORPORATION. All rights reserved.

MANUAL NO. TOBP C730600 42A  
Published in Japan August 2008 08-8  
08-5-3