

AC SERVOMOTORS/SERVO DRIVES

G5-series WITH BUILT-IN EtherCAT® COMMUNICATIONS

User's Manual

R88M-K□ (AC Servomotors)

R88D-KN□-ECT (AC Servo Drives)



© **OMRON, 2011**

All rights reserved. No part of this publication may be reproduced, stored in a retrieval system, or transmitted, in any form, or by any means, mechanical, electronic, photocopying, recording, or otherwise, without the prior written permission of OMRON.

No patent liability is assumed with respect to the use of the information contained herein. Moreover, because OMRON is constantly striving to improve its high-quality products, the information contained in this manual is subject to change without notice. Every precaution has been taken in the preparation of this manual. Nevertheless, OMRON assumes no responsibility for errors or omissions. Neither is any liability assumed for damages resulting from the use of the information contained in this publication.

Trademarks

- EtherCAT® is registered trademark and patented technology, licensed by Bechhoff Automation GmbH, Germany.
- ODVA, CIP, CompoNet, DeviceNet, and EtherNet/IP are trademarks of ODVA.

Other company names and product names in this document are the trademarks or registered trademarks of their respective companies.

Introduction

Thank you for purchasing a G5-series Servo Drive. This manual explains how to install and wire the Servo Drive, set parameters needed to operate the Servo Drive, and remedies to be taken and inspection methods to be used should problems occur.

Intended Readers

This manual is intended for the following individuals.

Those having electrical knowledge (certified electricians or individuals having equivalent knowledge) and also being qualified for one of the following:

- Introducing FA equipment
- Designing FA systems
- Managing FA sites

Notice

This manual contains information you need to know to correctly use the Servo Drive and peripheral equipment. Before using the Servo Drive, read this manual and gain a full understanding of the information provided herein.

After you finished reading this manual, keep it in a convenient place so that it can be referenced at any time.

Make sure this manual is delivered to the end user.

Terms and Conditions Agreement

Warranty, Limitations of Liability

Warranties

● Exclusive Warranty

Omron's exclusive warranty is that the Products will be free from defects in materials and workmanship for a period of twelve months from the date of sale by Omron (or such other period expressed in writing by Omron). Omron disclaims all other warranties, express or implied.

● Limitations

OMRON MAKES NO WARRANTY OR REPRESENTATION, EXPRESS OR IMPLIED, ABOUT NON-INFRINGEMENT, MERCHANTABILITY OR FITNESS FOR A PARTICULAR PURPOSE OF THE PRODUCTS. BUYER ACKNOWLEDGES THAT IT ALONE HAS DETERMINED THAT THE PRODUCTS WILL SUITABLY MEET THE REQUIREMENTS OF THEIR INTENDED USE.

Omron further disclaims all warranties and responsibility of any type for claims or expenses based on infringement by the Products or otherwise of any intellectual property right.

● Buyer Remedy

Omron's sole obligation hereunder shall be, at Omron's election, to (i) replace (in the form originally shipped with Buyer responsible for labor charges for removal or replacement thereof) the non-complying Product, (ii) repair the non-complying Product, or (iii) repay or credit Buyer an amount equal to the purchase price of the non-complying Product; provided that in no event shall Omron be responsible for warranty, repair, indemnity or any other claims or expenses regarding the Products unless Omron's analysis confirms that the Products were properly handled, stored, installed and maintained and not subject to contamination, abuse, misuse or inappropriate modification. Return of any Products by Buyer must be approved in writing by Omron before shipment. Omron Companies shall not be liable for the suitability or unsuitability or the results from the use of Products in combination with any electrical or electronic components, circuits, system assemblies or any other materials or substances or environments. Any advice, recommendations or information given orally or in writing, are not to be construed as an amendment or addition to the above warranty.

See <http://www.omron.com/global/> or contact your Omron representative for published information.

Limitation on Liability; Etc

OMRON COMPANIES SHALL NOT BE LIABLE FOR SPECIAL, INDIRECT, INCIDENTAL, OR CONSEQUENTIAL DAMAGES, LOSS OF PROFITS OR PRODUCTION OR COMMERCIAL LOSS IN ANY WAY CONNECTED WITH THE PRODUCTS, WHETHER SUCH CLAIM IS BASED IN CONTRACT, WARRANTY, NEGLIGENCE OR STRICT LIABILITY.

Further, in no event shall liability of Omron Companies exceed the individual price of the Product on which liability is asserted.

Application Considerations

Suitability of Use

Omron Companies shall not be responsible for conformity with any standards, codes or regulations which apply to the combination of the Product in the Buyer's application or use of the Product. At Buyer's request, Omron will provide applicable third party certification documents identifying ratings and limitations of use which apply to the Product. This information by itself is not sufficient for a complete determination of the suitability of the Product in combination with the end product, machine, system, or other application or use. Buyer shall be solely responsible for determining appropriateness of the particular Product with respect to Buyer's application, product or system. Buyer shall take application responsibility in all cases.

NEVER USE THE PRODUCT FOR AN APPLICATION INVOLVING SERIOUS RISK TO LIFE OR PROPERTY WITHOUT ENSURING THAT THE SYSTEM AS A WHOLE HAS BEEN DESIGNED TO ADDRESS THE RISKS, AND THAT THE OMRON PRODUCT(S) IS PROPERLY RATED AND INSTALLED FOR THE INTENDED USE WITHIN THE OVERALL EQUIPMENT OR SYSTEM.

Programmable Products

Omron Companies shall not be responsible for the user's programming of a programmable Product, or any consequence thereof.

Disclaimers

Performance Data

Data presented in Omron Company websites, catalogs and other materials is provided as a guide for the user in determining suitability and does not constitute a warranty. It may represent the result of Omron's test conditions, and the user must correlate it to actual application requirements. Actual performance is subject to the Omron's Warranty and Limitations of Liability.

Change in Specifications

Product specifications and accessories may be changed at any time based on improvements and other reasons. It is our practice to change part numbers when published ratings or features are changed, or when significant construction changes are made. However, some specifications of the Product may be changed without any notice. When in doubt, special part numbers may be assigned to fix or establish key specifications for your application. Please consult with your Omron's representative at any time to confirm actual specifications of purchased Product.

Errors and Omissions



Information presented by Omron Companies has been checked and is believed to be accurate; however, no responsibility is assumed for clerical, typographical or proofreading errors or omissions.

Safety Precautions

- To ensure that the G5-series Servomotor and Servo Drive as well as peripheral equipment are used safely and correctly, be sure to read this Safety Precautions section and the main text before using the product in order to learn items you should know regarding the equipment as well as required safety information and precautions.
- Make an arrangement so that this manual also gets to the end user of this product.
- After reading this manual, keep it in a convenient place so that it can be referenced at any time.

Definition of Precautionary Information

- The precautions explained in this section describe important information regarding safety and must be followed without fail.
- The display of precautions in this manual and their meanings are explained below.

 DANGER	Indicates an imminently hazardous situation which, if not avoided, will result in death or serious injury. Additionally, there may be severe property damage.
 Caution	Indicates a potentially hazardous situation which, if not avoided, may result in minor or moderate injury, or property damage.

Even those items denoted by the caution symbol may lead to a serious outcome depending on the situation. Accordingly, be sure to observe all safety precautions.



Precautions for Safe Use

Indicates precautions on what to do and what not to do to ensure using the product safely.



Precautions for Correct Use



Indicates precautions on what to do and what not to do to ensure proper operation and performance.



Additional Information

Indicates an item that helps deepen your understanding of the product or other useful tip.

Explanation of Symbols

Example of symbols	
	<p>△ This symbol indicates danger and caution.</p> <p>The specific instruction is indicated using an illustration or text inside or near △. The symbol shown to the left indicates “beware of electric shock.”</p>
	<p>⊘ This symbol indicates a prohibited item (an item you must not do).</p> <p>The specific instruction is indicated using an illustration or text inside or near ⊘. The symbol shown to the left indicates “disassembly prohibited,”</p>
	<p>● This symbol indicates a compulsory item (an item that must be done).</p> <p>The specific instruction is indicated using an illustration or text inside or near ●. The symbol shown to the left indicates “grounding required,”</p>

Precautions for Safe Use of This Product

- Illustrations contained in this manual sometimes depict conditions without covers and safety shields for the purpose of showing the details. When using this product, be sure to install the covers and shields as specified and use the product according to this manual.
- If the product has been stored for an extended period of time, contact your OMRON sales representative.



DANGER



Always connect the frame ground terminals of a 100 V or 200 V type drive and motor to a type-D or higher ground. Always connect the ground terminals of a 400 V type to a type-C or higher ground. Improper grounding may result in electrical shock.



Never touch the parts inside the Servo Drive.
Electric shock may result.



While the power is supplied, do not remove the front cover, terminal covers, cables, and options.
Electric shock may result.



Installation, operation, and maintenance or inspection by unauthorized personnel is prohibited.
Electric shock or injury may result.



Before carrying out wiring or inspection, turn OFF the main circuit power and wait for at least 15 minutes.
Electric shock may result.



Do not damage, pull, stress strongly, or pinch the cables or place heavy articles on them.
Electric shock, stopping of Servo Drive operation, or burn damage may result.



Never touch the rotating part of the Servomotor during operation.
Injury may result.



Never modify the Servo Drive.
Injury or equipment damage may result.

DANGER



Install a stopping device on the machine to ensure safety.
 * The holding brake is not a stopping device to ensure safety.
 Injury may result.



Install an immediate stop device externally to the machine so that the operation can be stopped and the power supply cut off immediately.
 Injury may result.



When the power is restored after a momentary power interruption, the machine may restart suddenly. Never come close to the machine when restoring power.
 * Implement measures to ensure safety of people nearby even when the machine is restarted.
 Injury may result.



After an earthquake, be sure to conduct safety checks.
 Electric shock, injury, or fire may result.



Never drive the Servomotor using an external drive source.
 Fire may result.



Do not place flammable materials near the Servomotor, Servo Drive, or Regeneration Resistor.
 Fire may result.



Install the Servomotor, Servo Drive, and Regeneration Resistor on non-flammable materials such as metals.
 Fire may result.



When you perform a system configuration using the safety function, be sure to fully understand the relevant safety standards and the information in the operation manual, and apply them to the system design.
 Injury or damage may result.



Do not use the cable when it is laying in oil or water.
 Electric shock, injury, or fire may result.



Never connect a commercial power supply directly to the Servomotor.
 Fire or failure may result.



Do not perform wiring or any operation with wet hands.
 Electric shock, injury, or fire may result.



Do not touch the key grooves with bare hands if a Servomotor with shaft-end key grooves is being used.
 Injury may result.



Caution



Use the Servomotor and Servo Drive in a specified combination.
Fire or equipment damage may result.



Do not store or install the Servo Drive in the following locations:

- Location subject to direct sunlight
- Location where the ambient temperature exceeds the specified level
- Location where the relative humidity exceeds the specified level
- Location subject to condensation due to rapid temperature changes
- Location subject to corrosive or flammable gases
- Location subject to high levels of dust, salt content, or iron dust
- Location subject to splashes of water, oil, chemicals, etc.
- Location where the Servo Drive may receive vibration or impact directly

Installing or storing the Servo Drive in any of these locations may result in fire, electric shock, or equipment damage.



The Servo Drive radiator, Regeneration Resistor, Servomotor, etc., may become hot while the power is supplied or remain hot for a while even after the power supply is cut off. Never touch these components.
A burn injury may result.

Storage and Transportation



Caution



When transporting the Servo Drive, do not hold it by the cables or Servomotor shaft.
Injury or failure may result.



Do not overload the Servo Drive or Servomotor. (Follow the instructions on the product label.)
Injury or failure may result.



Use the Servomotor eye-bolts only when transporting the Servomotor.
Do not use them to transport the machine.
Injury or failure may result.



When lifting a 15 kW or higher Servo Drive during moving or installation, always have two people lift the product by grasping a metal part. Do not grasp a plastic part.
Risk of injury or product damage.

Installation and Wiring



Caution



Do not step on the Servo Drive or place heavy articles on it.
Injury may result.



Do not block the intake or exhaust openings. Do not allow foreign objects to enter the Servo Drive.
Fire may result.



Be sure to observe the mounting direction.
Failure may result.



Provide the specified clearance between the Servo Drive and the inner surface of the control panel or other equipment.
Fire or failure may result.



Do not apply strong impact on the Servomotor shaft or Servo Drive.
Failure may result.



Wire the cables correctly and securely.
Runaway Servomotor, injury, or failure may result.



Securely tighten the mounting screws, terminal block screws, and cable screws.
Failure may result.



Use crimp terminals for wiring.
If simple twisted wires are connected directly to the protective ground terminal, fire may result.



Only use the power supply voltage specified in this manual.
Burn damage may result.



In locations where the power supply infrastructure is poor, make sure the rated voltage can be supplied.
Equipment damage may result.



Provide safety measures, such as a breaker, to protect against short circuiting of external wiring.
Fire may result.



If the Servo Drive is used in the following locations, provide sufficient shielding measures.

- Location subject to noise e.g., due to static electricity
- Location subject to a strong electric or magnetic field
- Location where exposure to radioactivity may occur
- Location near power supply lines

Using the Servo Drive in any of these locations may result in equipment damage.



Connect an immediate stop relay in series with the brake control relay.
Injury or failure may result.



When connecting the battery, make sure the polarity is correct.
Battery damage or explosion may result.

Operation and Adjustment



Caution



Conduct a test operation after confirming that the equipment is not affected.
Equipment damage may result.



Before operating the Servo Drive in an actual environment, check if it operates correctly based on the parameters you have set.
Equipment damage may result.



Never adjust or set parameters to extreme values, because it will make the operation unstable.
Injury may result.



Separate the Servomotor from the mechanical system and check its operation before installing the Servomotor to the machine.
Injury may result.



If an error occurs, remove the cause of the error and ensure safety, and then reset the alarm and restart the operation.
Injury may result.



Do not use the built-in brake of the Servomotor for normal braking operation.
Failure may result.



Do not operate the Servomotor connected to an excessive load inertia.
Failure may result.



Install safety devices to prevent idling or locking of the electromagnetic brake or the gear head, or leakage of grease from the gear head.
Injury, damage, or taint damage result.



If the Servo Drive fails, cut off the power supply to the Servo Drive at the power supply.
Fire may result.



Do not turn ON and OFF the main Servo Drive power supply frequently.
Failure may result.

Maintenance and Inspection



Caution



After replacing the Servo Drive, transfer to the new Servo Drive all data needed to resume operation, before restarting operation.
Equipment damage may result.



Never repair the Servo Drive by disassembling it.
Electric shock or injury may result.



Be sure to turn OFF the power supply when the Servo Drive is not going to be used for a prolonged period of time.
Injury may result.

Location of Warning Label

The Servo Drive bears a warning label at the following location to provide handling warnings. When handling the Servo Drive, be sure to observe the instructions provided on this label.

Warning label display location

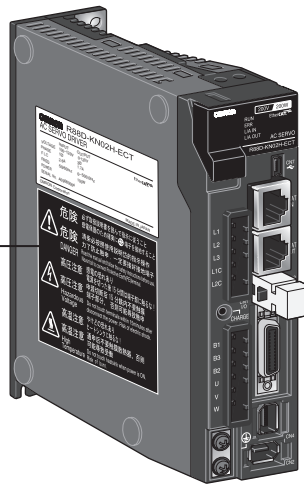

(R88D-KN02H-ECT)

Instructions on Warning Label

	危険 危険 DANGER	必ず取扱説明書を読んで指示に従うこと 感電保護のため確実に⊕端子を接地すること 请务必按照使用说明书的指示操作 为了防止触电，一定要接好接地端子 Read the manual and follow the safety instructions before use. Never fail to connect Protective Earth(PE) terminal.
	高圧注意 高圧注意 Hazardous Voltage	感電の恐れあり 電源を切った後15分間は端子部に触るな! 电源切断后15分钟内不要触摸 端子部分，否则可能导致触电 Do not touch terminals within 15 minutes after disconnect the power. Risk of electric shock.
	高温注意 高温注意 High Temperature	やけどの恐れあり ヒートシンクに触るな! 通电后不要触摸散热器，否则 可能导致受伤 Do not touch heatsink when power is ON. Risk of burn.

Disposal

- When disposing of the battery, insulate it using tape, and dispose of it by following the applicable ordinances of your local government.
- Dispose of the Servo Drive as industrial waste.

Items to Check after Unpacking

After unpacking, check the following items.

- Is this the model you ordered?
- Was there any damage sustained during shipment?

Accessories

Safety Precautions document x 1 copy

- Connectors, mounting screws, mounting brackets, and other accessories other than those in the table below are not supplied. They must be prepared by the customer.
- If any item is missing or a problem is found such as Servo Drive damage, contact the OMRON dealer or sales office where you purchased your product.

Specifications		Connector for main circuit power supply terminals and control circuit power supply terminals	Connector for External Regeneration Resistor connection terminals and Motor connection terminals	Safety bypass connector	Mounting Brackets		
Single-phase 100 VAC	50 W	Included		Included	-		
	100 W						
	200 W						
	400 W						
Single-phase/3-phase 200 VAC	100 W	-		-	-		
	200 W						
	400 W						
	750 W						
	1 kW						
	1.5 kW						
3-phase 200 VAC	2 kW	-		-	Included		
	3 kW						
	5 kW						
	7.5 kW						
	15 kW						
3-phase 400 VAC	600 W	Included		-	-		
	1 kW						
	1.5 kW						
	2 kW						
	3 kW	-			-	Included	
							5 kW
							7.5 kW
							15 kW

Revision History

The manual revision code is a number appended to the end of the catalog number found in the bottom left-hand corner of the front or back cover.

Example

Cat. No. I576-E1-03

↑
Revision code

Revision code	Revision Date	Revised content
01	January 2011	Original production
02	July 2011	Add description on functions associated with unit version 2.1 and correct errors in writing on Rev.01.
03	March 2015	Added information and made corrections.

Structure of This Document

This manual consists of the following chapters.

Read the necessary chapter or chapters referring the following table.

		Outline
Chapter 1	Features and System Configuration	This chapter explains the features of the Servo Drive, name of each part, and applicable EC Directives and UL standards.
Chapter 2	Models and External Dimensions	This chapter explains the models of Servo Drives, Servomotors, and peripheral equipment, and provides the external dimensions and mounting dimensions.
Chapter 3	Specifications	This chapter provides the general specifications, characteristics, connector specifications, and I/O circuits of the Servo Drives as well as the general specifications, characteristics, encoder specifications of the Servomotors and other peripheral devices.
Chapter 4	System Design	This chapter explains the installation conditions for the Servo Drive, Servomotor, and Decelerator, wiring methods including wiring conforming to EMC Directives and regenerative energy calculation methods as well as the performance of External Regeneration Resistors.
Chapter 5	EtherCAT Communications	This chapter describes EtherCAT communications under the assumption that the G5-series Servo Drive is connected to a Machine Automation Controller NJ-series (Model: NJ501-1□00) or Position Control Unit (CJ1W-NC281/NC481/NC881/NCF81/NC482/NC882).
Chapter 6	Basic Control Functions	This chapter describes the profile that is used to control the Servo Drive.
Chapter 7	Applied Functions	This chapter outlines the applied functions such as the electronic gear, gain switching and soft start, and explains the settings.
Chapter 8	Safety Function	This chapter gives an outline of application functions, such as electronic gears, gain switching, and soft start, and explains the settings.
Chapter 9	Details on Servo Parameter Objects	This chapter explains the set values and contents of each object.
Chapter 10	Operation	This chapter gives the operating procedures and explains how to operate in each mode.
Chapter 11	Adjustment Functions	This chapter explains the functions, setting methods, and items to note regarding various gain adjustments.
Chapter 12	Troubleshooting and Maintenance	This chapter explains the items to check when problems occur, error diagnosis using the error display and measures, error diagnosis based on the operating condition and measures, and periodic maintenance.
Appendices		The appendix provides explanation for the profile that is used to control the Servo Drive, lists of objects, Sysmac Error Status codes, and other information.

Contents

Introduction	1
Terms and Conditions Agreement.....	2
Safety Precautions	4
Items to Check after Unpacking.....	12
Revision History	13
Structure of This Document.....	14
Contents	16

Section 1 Features and System Configuration

1-1 Outline	1-2
1-1-1 Features of G5-series Servo Drives.....	1-2
1-1-2 What Is EtherCAT?.....	1-3
1-1-3 Object Dictionary.....	1-3
1-2 System Configuration	1-4
1-3 Names and Functions	1-5
1-3-1 Servo Drive Part Names	1-5
1-3-2 Servo Drive Functions.....	1-6
1-4 System Block Diagram.....	1-7
1-5 Applicable Standards	1-16
1-5-1 EC Directives	1-16
1-5-2 UL and cUL Standards.....	1-16
1-5-3 Korean Radio Regulations (KC).....	1-17
1-5-4 SEMI F47	1-17
1-6 Unit Versions.....	1-18
1-6-1 Confirmation Method.....	1-18
1-6-2 Unit Versions	1-18

Section 2 Models and External Dimensions

2-1 Servo System Configuration	2-2
2-2 How to Read Model Numbers	2-4
2-2-1 Servo Drive	2-4
2-2-2 Servomotors.....	2-5
2-2-3 Reduction Gear (3 Arcminutes Max.).....	2-6
2-2-4 Reduction Gear (15 Arcminutes Max.).....	2-7
2-3 Model Tables	2-8
2-3-1 Servo Drive Model Table	2-8
2-3-2 Servomotor Model Tables	2-9
2-3-3 Servo Drive and Servomotor Combination Tables	2-14
2-3-4 Reduction Gear Model Tables.....	2-16
2-3-5 Cable and Peripheral Device Model Tables.....	2-20

2-4	External and Mounting Dimensions	2-28
2-4-1	Servo Drive Dimensions	2-28
2-4-2	Servomotor Dimensions	2-44
2-4-3	Combinations of Servomotors and Reduction Gears	2-70
2-4-4	Reduction Gear Dimensions.....	2-72
2-4-5	External Regeneration Resistor Dimensions	2-86
2-4-6	Reactor Dimensions	2-87
2-4-7	Mounting Bracket (L-brackets for Rack Mounting) Dimensions	2-91

Section 3 Specifications

3-1	Servo Drive Specifications	3-2
3-1-1	General Specifications.....	3-2
3-1-2	Characteristics	3-3
3-1-3	EtherCAT Communications Specifications	3-7
3-1-4	Main Circuit and Motor Connections.....	3-8
3-1-5	EtherCAT Communications Connector Specifications (RJ45).....	3-17
3-1-6	Control I/O Connector Specifications (CN1).....	3-18
3-1-7	Control Input Circuits	3-21
3-1-8	Control Input Details	3-21
3-1-9	Control Output Circuits	3-23
3-1-10	Control Output Details	3-24
3-1-11	Encoder Connector Specifications (CN2).....	3-28
3-1-12	External Encoder Connector Specifications (CN4).....	3-28
3-1-13	Analog Monitor Connector Specifications (CN5)	3-31
3-1-14	USB Connector Specifications (CN7).....	3-32
3-1-15	Safety Connector Specifications (CN8)	3-33
3-2	Overload Characteristics (Electronic Thermal Function)	3-35
3-2-1	Overload Characteristics Graphs.....	3-35
3-3	Servomotor Specifications	3-36
3-3-1	General Specifications.....	3-36
3-3-2	Characteristics.....	3-37
3-3-3	Encoder Specifications	3-59
3-4	Reduction Gear Specifications	3-60
3-4-1	Models and Specifications	3-60
3-5	Cable and Connector Specifications	3-67
3-5-1	Bend Radius of Robot Cable	3-67
3-5-2	Encoder Cable Specifications.....	3-69
3-5-3	Absolute Encoder Battery Cable Specifications	3-74
3-5-4	Motor Power Cable Specifications	3-75
3-5-5	Connector Specifications.....	3-91
3-5-6	EtherCAT Communications Cable Specifications	3-94
3-5-7	Analog Monitor Cable Specifications	3-97
3-5-8	Control Cable Specifications.....	3-99
3-6	External Regeneration Resistor Specifications.....	3-104
3-6-1	External Regeneration Resistor Specifications	3-104
3-7	Reactor Specifications.....	3-106
3-7-1	Specifications.....	3-106

Section 4 System Design

4-1	Installation Conditions.....	4-2
4-1-1	Servo Drive Installation Conditions.....	4-2
4-1-2	Servomotor Installation Conditions	4-3
4-1-3	Decelerator Installation Conditions	4-6

4-2	Wiring	4-10
4-2-1	Power Cables for 1,500-r/min Servomotors	4-10
4-2-2	Peripheral Equipment Connection Examples	4-11
4-2-3	Main Circuit and Motor Connections	4-21
4-3	Wiring Conforming to EMC Directives	4-35
4-3-1	Wiring Method	4-35
4-3-2	Selecting Connection Component.....	4-44
4-4	Regenerative Energy Absorption	4-56
4-4-1	Calculating the Regenerative Energy	4-56
4-4-2	Servo Drive Regeneration Absorption Capacity	4-58
4-4-3	Regenerative Energy Absorption with an External Regeneration Resistor	4-59
4-4-4	Connecting an External Regeneration Resistor	4-60
4-5	Using DC Power Input	4-63
4-5-1	Connection Example for Using DC power Input.....	4-64

Section 5 EtherCAT Communications

5-1	Display Area and Settings	5-2
5-1-1	Node Address Setting	5-2
5-1-2	Status Indicators	5-3
5-2	Structure of the CAN Application Protocol over EtherCAT	5-4
5-3	EtherCAT State Machine	5-5
5-4	Process Data Objects (PDOs)	5-6
5-4-1	PDO Mapping Settings.....	5-6
5-4-2	Sync Manager PDO Assignment Settings	5-7
5-4-3	Fixed PDO Mapping	5-7
5-4-4	Variable PDO Mapping.....	5-9
5-4-5	Multiple PDO Mapping	5-10
5-5	Service Data Objects (SDOs)	5-12
5-5-1	Abort Codes	5-12
5-6	Synchronization with Distributed Clocks	5-13
5-6-1	Communications Cycle (DC Cycle).....	5-13
5-7	Emergency Messages	5-14
5-8	Sysmac Device Features	5-15

Section 6 Basic Control Functions

6-1	Cyclic Synchronous Position Mode	6-2
6-1-1	Related Objects.....	6-3
6-1-2	Block Diagram for Position Control Mode.....	6-4
6-2	Cyclic Synchronous Velocity Mode	6-5
6-2-1	Related Objects.....	6-6
6-2-2	Objects Requiring Settings	6-6
6-2-3	Related Functions	6-6
6-2-4	Block Diagram for Speed Control Mode.....	6-7
6-3	Cyclic Synchronous Torque Mode	6-8
6-3-1	Related Objects.....	6-9
6-3-2	Objects Requiring Settings	6-9
6-3-3	Related Functions	6-9
6-3-4	Block Diagram for Torque Control Mode	6-10

6-4	Profile Position Mode	6-11
6-4-1	Related Objects	6-12
6-4-2	Description of Function	6-13
6-4-3	Controlword (6040 hex) in Profile Position Mode.....	6-14
6-4-4	Statusword (6041 hex) in Profile Position Mode	6-14
6-5	Homing Mode	6-15
6-6	Fully-closed Control	6-16
6-6-1	Outline of Operation.....	6-16
6-6-2	Objects Requiring Settings	6-17
6-6-3	Block Diagram for Fully-closed Control Mode.....	6-22
6-7	Connecting with OMRON Controllers	6-23

Section 7 Applied Functions

7-1	Sequence I/O Signals	7-2
7-1-1	Input Signals	7-2
7-1-2	Output Signals	7-5
7-2	Forward and Reverse Drive Prohibition Functions	7-8
7-2-1	Objects Requiring Settings	7-8
7-3	Overrun Protection	7-11
7-3-1	Operating Conditions	7-11
7-3-2	Objects Requiring Settings	7-11
7-3-3	Operation Example	7-12
7-4	Backlash Compensation	7-13
7-4-1	Objects Requiring Settings	7-13
7-5	Brake Interlock	7-15
7-5-1	Objects Requiring Settings	7-15
7-5-2	Operation Timing	7-16
7-6	Electronic Gear Function	7-21
7-6-1	Objects Requiring Settings	7-21
7-6-2	Operation Example	7-22
7-7	Torque Limit Switching	7-24
7-7-1	Operating Conditions	7-24
7-7-2	Objects Requiring Settings	7-24
7-8	Soft Start	7-26
7-8-1	Objects Requiring Settings	7-26
7-8-2	Soft Start Acceleration or Deceleration Time	7-26
7-8-3	S-curve Acceleration or Deceleration Time	7-27
7-9	Gain Switching Function	7-28
7-9-1	Objects Requiring Settings	7-29
7-9-2	Gain Switching Based on the Control Mode	7-30
7-9-3	Diagrams of Gain Switching Setting	7-35
7-9-4	Position Gain Switching Time (3119 Hex)	7-37
7-10	Gain Switching 3 Function	7-38
7-10-1	Operating Conditions	7-38
7-10-2	Objects Requiring Settings	7-38
7-10-3	Operation Example	7-38
7-11	Touch Probe Function (Latch Function)	7-40
7-11-1	Related Objects	7-40
7-11-2	Trigger Signal Settings.....	7-40
7-11-3	Operation Sequences	7-41

Section 8 Safety Function

8-1 Safe Torque OFF Function	8-2
8-1-1 I/O Signal Specifications	8-3
8-2 Operation Example	8-5
8-3 Connection Examples	8-7

Section 9 Details on Servo Parameter Objects

9-1 Basic Settings	9-2
9-2 Gain Settings	9-7
9-3 Vibration Suppression Settings	9-20
9-4 Analog Control Objects	9-26
9-5 Interface Monitor Settings	9-31
9-6 Extended Objects	9-41
9-7 Special Objects	9-47

Section 10 Operation

10-1 Operational Procedure	10-2
10-2 Preparing for Operation	10-3
10-2-1 Items to Check Before Turning ON the Power Supply	10-3
10-2-2 Turning ON the Power Supply	10-4
10-2-3 Checking the Displays	10-5
10-2-4 Absolute Encoder Setup	10-7
10-2-5 Setting Up an Absolute Encoder from the CX-Drive	10-7
10-3 Trial Operation	10-8
10-3-1 Preparations for Trial Operation	10-8
10-3-2 Test Operation via USB Communications from the CX-Drive	10-9

Section 11 Adjustment Functions

11-1 Analog Monitor	11-2
11-1-1 Objects Requiring Settings	11-2
11-2 Gain Adjustment	11-5
11-2-1 Purpose of the Gain Adjustment	11-5
11-2-2 Gain Adjustment Methods	11-5
11-2-3 Gain Adjustment Procedure	11-6
11-3 Realtime Autotuning	11-7
11-3-1 Objects Requiring Settings	11-8
11-3-2 Setting Realtime Autotuning	11-8
11-3-3 Setting Machine Rigidity	11-9
11-4 Manual Tuning	11-15
11-4-1 Basic Settings	11-15
11-5 Damping Control	11-17
11-5-1 Objects Requiring Settings	11-17
11-5-2 Operating Procedure	11-18
11-6 Adaptive Filter	11-20
11-6-1 Objects Requiring Settings	11-21
11-6-2 Operating Procedure	11-22

11-7 Notch Filters	11-23
11-7-1 Objects Requiring Settings	11-24
11-7-2 Notch Filter Width and Depth.....	11-24
11-8 Disturbance Observer Function	11-26
11-8-1 Operating Conditions	11-26
11-8-2 Objects Requiring Settings	11-27
11-8-3 Operating Procedure	11-27
11-9 Friction Torque Compensation Function	11-28
11-9-1 Operating Conditions	11-28
11-9-2 Objects Requiring Settings	11-28
11-9-3 Operation Example	11-29
11-10 Hybrid Vibration Suppression Function	11-30
11-10-1 Operating Conditions	11-30
11-10-2 Objects Requiring Settings	11-30
11-10-3 Operating Procedure	11-30
11-11 Feed-forward Function	11-31
11-11-1 Objects Requiring Settings	11-31
11-11-2 Operating Procedure	11-32
11-12 Instantaneous Speed Observer Function	11-34
11-12-1 Operating Conditions	11-34
11-12-2 Objects Requiring Settings	11-34
11-12-3 Operating Procedure	11-35

Section 12 Troubleshooting and Maintenance

12-1 Troubleshooting	12-2
12-1-1 Preliminary Checks When a Problem Occurs.....	12-2
12-1-2 Precautions When a Problem Occurs.....	12-3
12-1-3 Replacing the Servomotor or Servo Drive	12-3
12-2 Warnings	12-5
12-2-1 Related Objects	12-5
12-2-2 Warning List.....	12-6
12-3 Errors	12-9
12-3-1 Error List	12-9
12-3-2 Immediate Stop Operation at Errors	12-12
12-4 Troubleshooting	12-14
12-4-1 Troubleshooting with Error Displays.....	12-14
12-4-2 Troubleshooting with the AL Status Code.....	12-29
12-4-3 Troubleshooting Using the Operation State	12-30
12-5 Periodic Maintenance	12-36
12-5-1 Servomotor Life Expectancy.....	12-36
12-5-2 Servo Drive Life Expectancy.....	12-37
12-5-3 Replacing the Absolute Encoder Battery	12-38

Appendices

A-1	CiA402 Drive Profile	A-2
A-1-1	Controlling the State Machine of the Servo Drive	A-2
A-1-2	Modes of Operation.....	A-4
A-1-3	Communications Cycles and Corresponding Modes of Operation	A-5
A-1-4	Modes of Operation and Applied Functions	A-6
A-1-5	Changing the Mode of Operation	A-7
A-1-6	Homing Mode Specifications.....	A-15
A-1-7	Object Dictionary.....	A-22
A-1-8	Communication Objects	A-24
A-1-9	PDO Mapping Objects	A-31
A-1-10	Sync Manager Communication Objects.....	A-44
A-1-11	Manufacturer Specific Objects	A-49
A-1-12	Servo Drive Profile Object.....	A-55
A-2	Object List	A-77
A-3	Sysmac Error Status Codes	A-94
A-3-1	Error Table.....	A-94
A-3-2	Error Description	A-108
A-4	EtherCAT Terminology	A-168
A-5	Functional Differences among Unit Versions	A-169

Index

1

Features and System Configuration

This chapter explains the features of the Servo Drive, name of each part, and applicable EC Directives and UL standards.

1-1	Outline	1-2
1-1-1	Features of G5-series Servo Drives	1-2
1-1-2	What Is EtherCAT?	1-3
1-1-3	Object Dictionary	1-3
1-2	System Configuration	1-4
1-3	Names and Functions	1-5
1-3-1	Servo Drive Part Names	1-5
1-3-2	Servo Drive Functions	1-6
1-4	System Block Diagram	1-7
1-5	Applicable Standards	1-16
1-5-1	EC Directives	1-16
1-5-2	UL and cUL Standards	1-16
1-5-3	Korean Radio Regulations (KC)	1-17
1-5-4	SEMI F47	1-17
1-6	Unit Versions	1-18
1-6-1	Confirmation Method	1-18
1-6-2	Unit Versions	1-18

1-1 Outline

The G5-series Servo Drives with Built-in EtherCAT Communications support 100-Mbps EtherCAT.

When you use the G5-series Servo Drive with a Machine Automation Controller NJ-series (Model: NJ501-1□00) or CJ1W-NC□8□ EtherCAT-compatible Position Control Unit, you can construct a sophisticated positioning control system. Also, you need only one communications cable to connect the Servo Drive and the Controller. Therefore, you can realize a position control system easily with reduced wiring effort.

With real time autotuning, adaptive filter, notch filter, and damping control, you can set up a system that provides stable operation by suppressing vibration in low-rigidity machines.

1-1-1 Features of G5-series Servo Drives

G5-series Servo Drives have the following features.

Optimal Functionality and Operability by Standardizing Specifications

As a Sysmac Device, you can use the G5-series AC Servo Drive (with Built-in EtherCAT Communications) together with the NJ-series Machine Automation Controller and the Sysmac Studio Automation Software to achieve optimum functionality and ease of operation.

* Sysmac Device is a generic term for OMRON control devices such as an EtherCAT Slave, designed with unified communications specifications and user interface specifications.

Data Transmission Using EtherCAT Communications

Combining the G5-series Servo Drive with a Machine Automation Controller NJ-series (Model: NJ501-1□00) or CJ1W-NC□8□ EtherCAT-compatible Position Control Unit enables you to exchange all position information with the controller in high-speed data communications.

Since the various control commands are transmitted via data communications, Servomotor's operational performance is maximized without being limited by interface specifications such as the response frequency of the encoder feedback pulses.

You can use the Servo Drive's various control parameters and monitor data on a host controller, and unify the system data for management.

Achievement of Accurate Positioning by Fully-closed Control

Feedback from the external encoder connected to the motor is used to accurately control positioning. Position control is not affected by deviations caused by ball screws or temperature changes.

Wide Range of Power Supplies to Meet Any Need

The G5 Series now has models supporting 400 V for use with large equipment, at overseas facilities and in wide-ranging applications and environment. Since the utilization ratio of facility equipment also increases, the TCO (total cost of ownership) will come down.

Safe Torque OFF (STO) Function to Ensure Safety

You can cut off the motor current to stop the motor based on a signal from an emergency stop button or other safety equipment. This can be used for an emergency stop circuit that is compliant with safety standards without using an external contactor. Even during the torque OFF status, the present position of the motor is monitored by the control circuits to eliminate the need to perform an origin search when restarting.

Suppressing Vibration of Low-rigidity Mechanisms during Acceleration/Deceleration

The damping control function suppresses vibration of low-rigidity mechanisms or devices whose tips tend to vibrate.

Two damping filters are provided to enable switching the damping frequency automatically according to the rotation direction and also via an external signal. In addition, the settings can be made easily by setting the damping frequency and filter values.

1-1-2 What Is EtherCAT?

EtherCAT is an open high-speed industrial network system that conforms to Ethernet (IEEE 802.3). Each node achieves a short cycle time by transmitting Ethernet frames at high speed. A mechanism that allows sharing clock information enables high-precision synchronization control with low communications jitter.

EtherCAT is a registered trademark of Beckhoff Automation GmbH (Germany). EtherCAT technology is protected by patents.

1-1-3 Object Dictionary

G5-series Servo Drives with Built-in EtherCAT Communications use the object dictionary for CAN application protocol over EtherCAT (CoE) as a base for communications.

An object is a special data structure inside a device that consists of data, parameters, and methods.

An object dictionary is a data structure that describes the data type objects, communications objects, and application objects.

All objects are assigned four-digit hexadecimal numbers in the areas shown in the following table.

Indexes	Area	Contents
0000 to 0FFF hex	Data Type Area	Definitions of data types.
1000 to 1FFF hex	CoE Communications Area	Definitions of variables that can be used by all servers for designated communications.
2000 to 2FFF hex	Manufacturer Specific Area 1	Variables with common definitions for all OMRON products.
3000 to 5FFF hex	Manufacturer Specific Area 2	Variables with common definitions for all G5-series Servo Drives (servo parameters). ^{*1}
6000 to 9FFF hex	Device Profile Area	Variables defined in the Servo Drive's CiA402 drive profile.
A000 to FFFF hex	Reserved Area	Area reserved for future use.

*1 G5-series Servo Drive parameters (Pn□□□) are allocated to objects 3000 to 3999 hex. Indexes 3□□□ hex correspond to G5-series Servo Drive parameters Pn□□□. For example, object 3504 hex is the same as parameter Pn504.

Pn□□□ uses decimal numbers but object 3□□□ is a hexadecimal number.

For details on servo parameters, refer to *Chapter 9 Details on Servo Parameter Objects*.

1-2 System Configuration

The system configuration for a G5-Series AC Servo Drive with Built-in EtherCAT Communications is shown below.

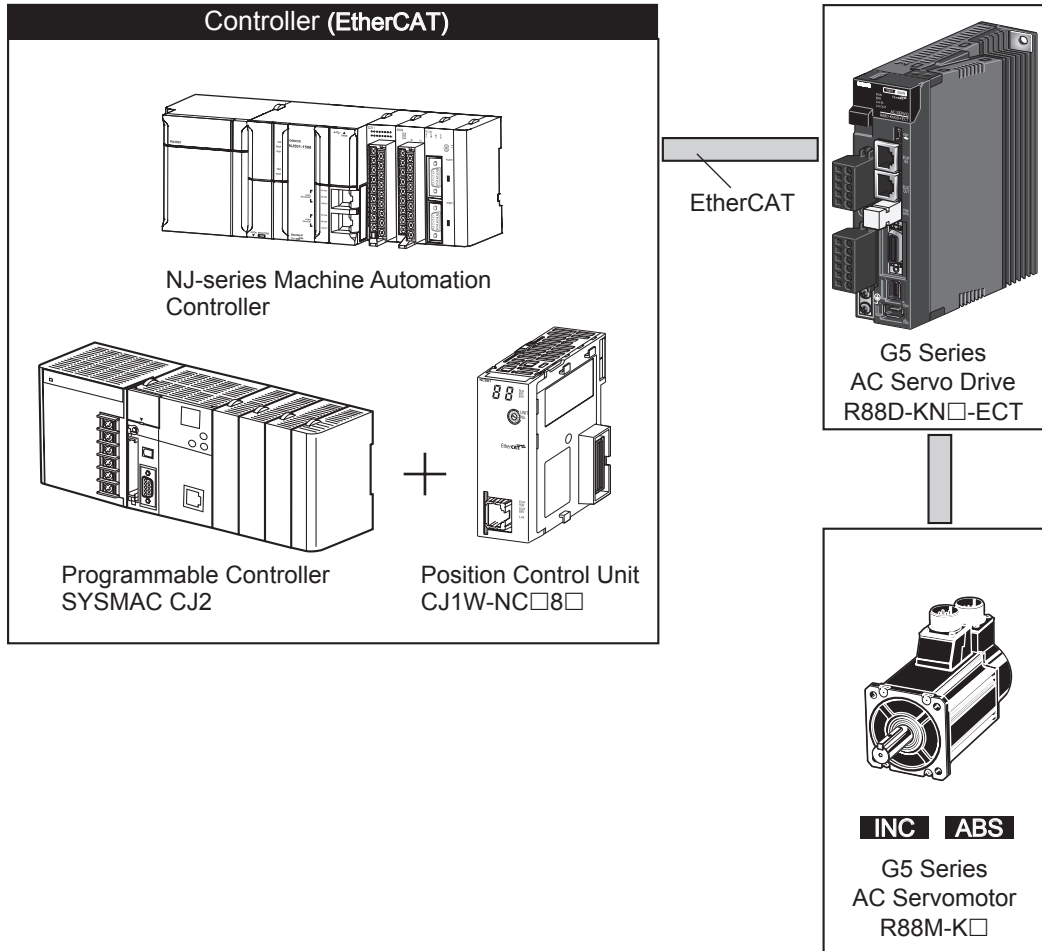

1-3 Names and Functions

This section describes the names and functions of Servo Drive parts.

1-3-1 Servo Drive Part Names

The Servo Drive part names are given below.

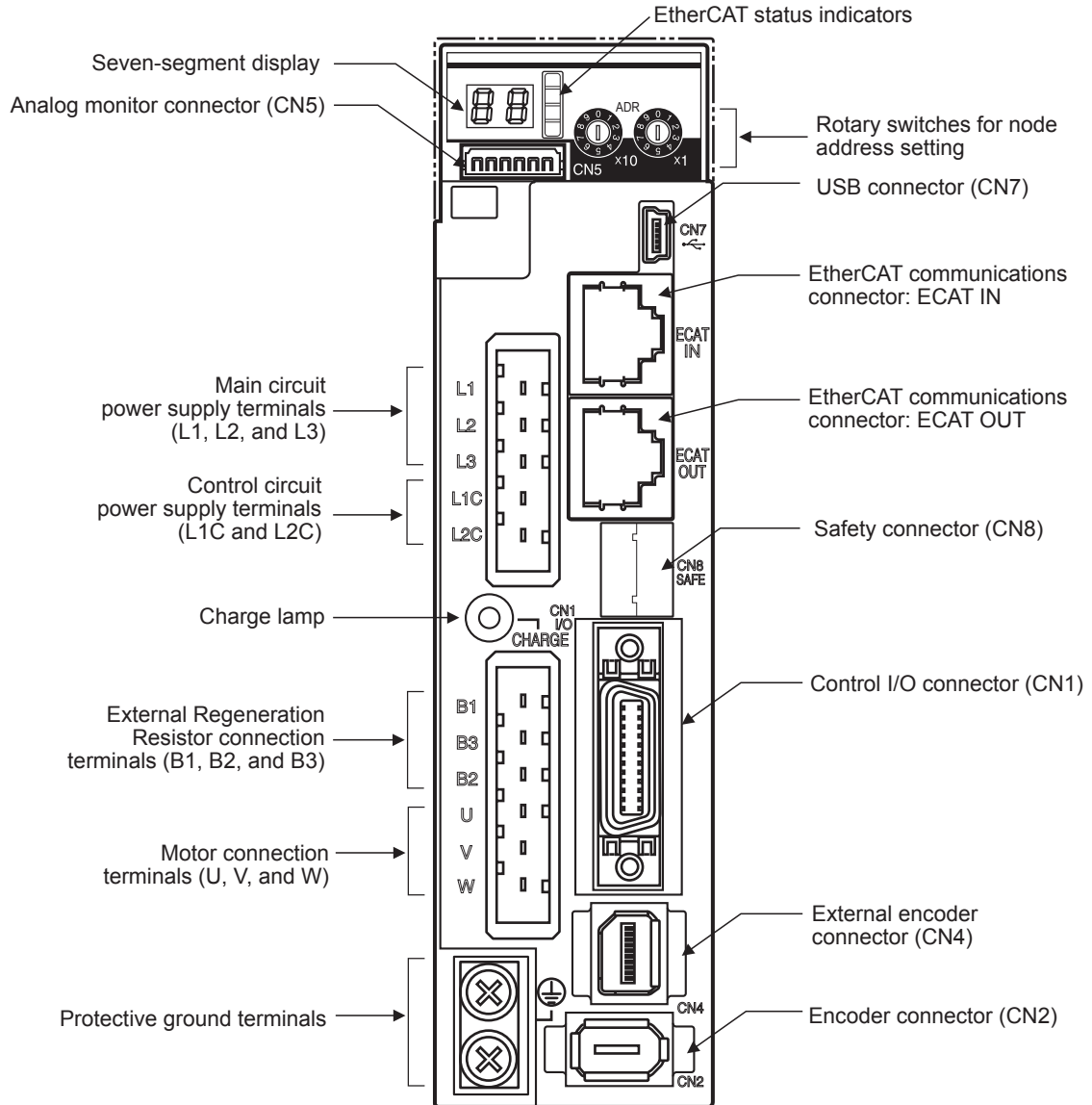

1-3-2 Servo Drive Functions

The functions of each part are described below.

Display

A 2-digit 7-segment display shows the node address, error codes, and other Servo Drive status.

Charge Lamp

Lights when the main circuit power supply is turned ON.

EtherCAT Status Indicators

These indicators show the status of EtherCAT communications.

For details, refer to *Status Indicators* on page 5-3.

Control I/O Connector (CN1)

Used for command input signals and I/O signals.

Encoder Connector (CN2)

Connector for the encoder installed in the Servomotor.

External Encoder Connector (CN4)

Connector for an encoder signal used during fully-closed control.

EtherCAT Communications Connectors (ECAT IN and ECAT OUT)

These connectors are for EtherCAT communications.

Analog Monitor Connector (CN5)

You can use a special cable to monitor values, such as the motor rotation speed, torque command value, etc.

USB Connector (CN7)

Communications connector for the computer.

Safety Connector (CN8)

Connector for safety devices.

If no safety devices are used, keep the factory-set safety bypass connector installed.

1-4 System Block Diagram

This is the block diagram of the G5-series AC Servo Drive with Built-in EtherCAT Communications.

R88D-KNA5L-ECT/-KN01L-ECT/-KN02L-ECT/-KN04L-ECT/
-KN01H-ECT/-KN02H-ECT/-KN04H-ECT/-KN08H-ECT

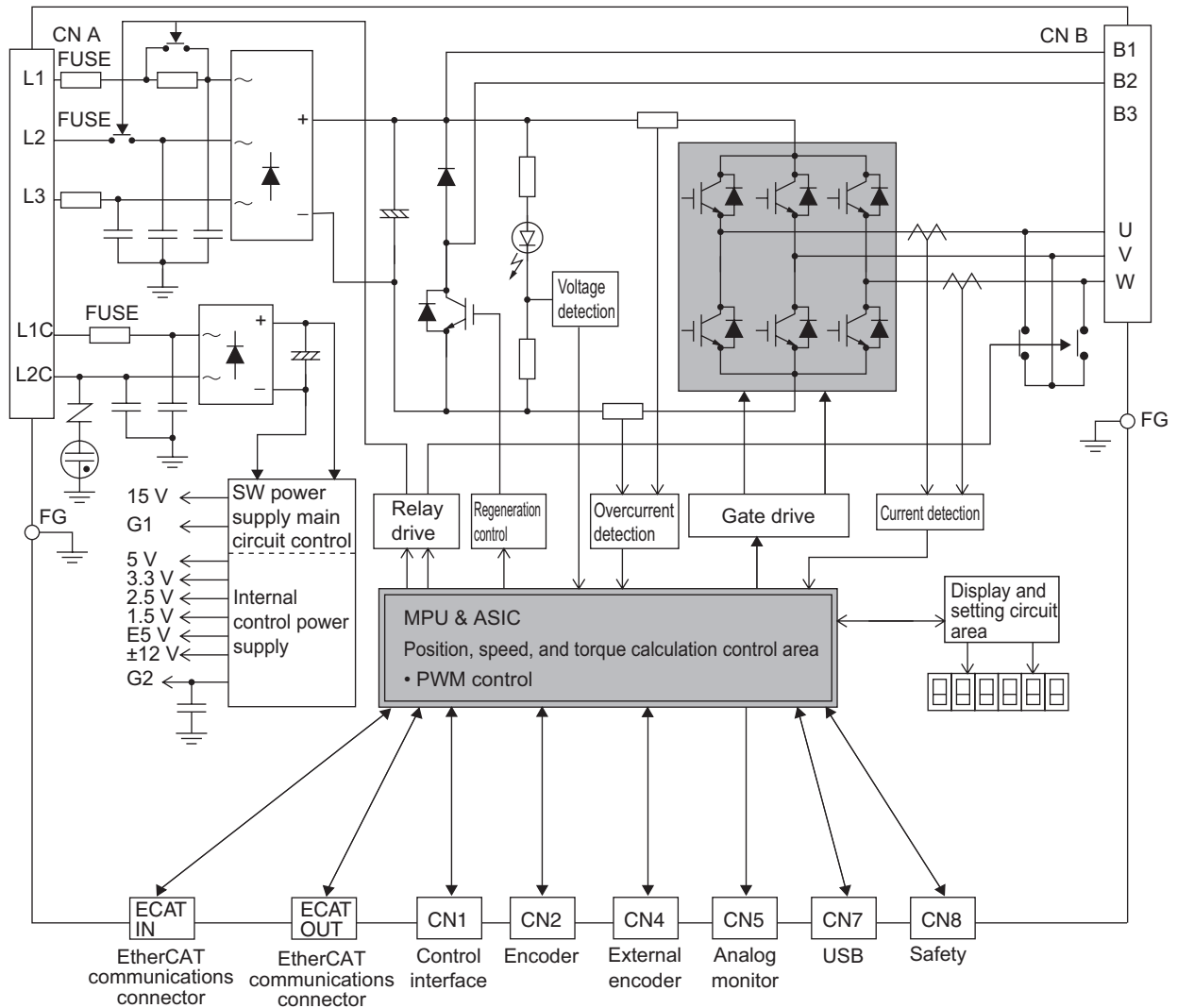

R88D-KN10H-ECT/-KN15H-ECT/-KN20H-ECT

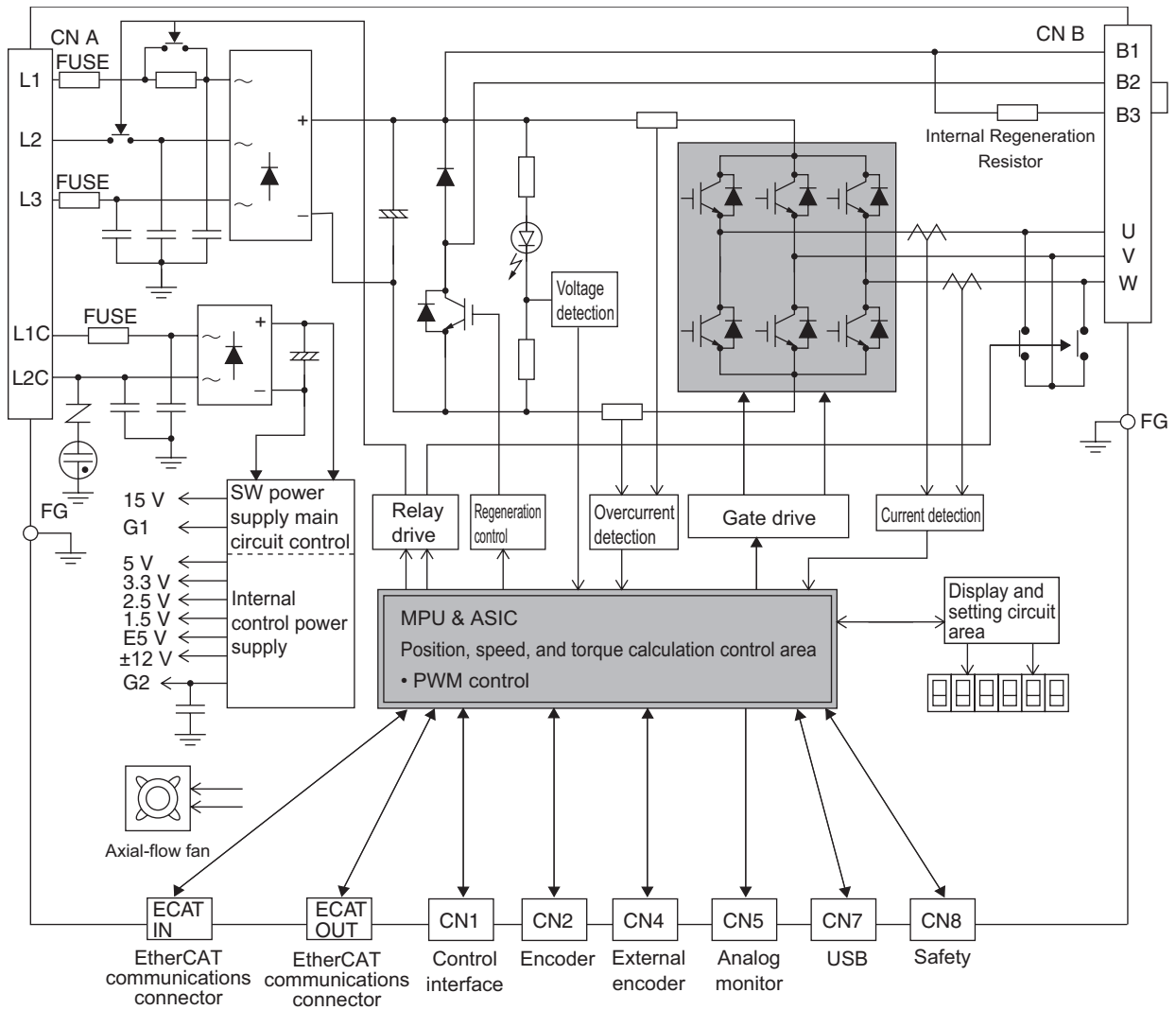

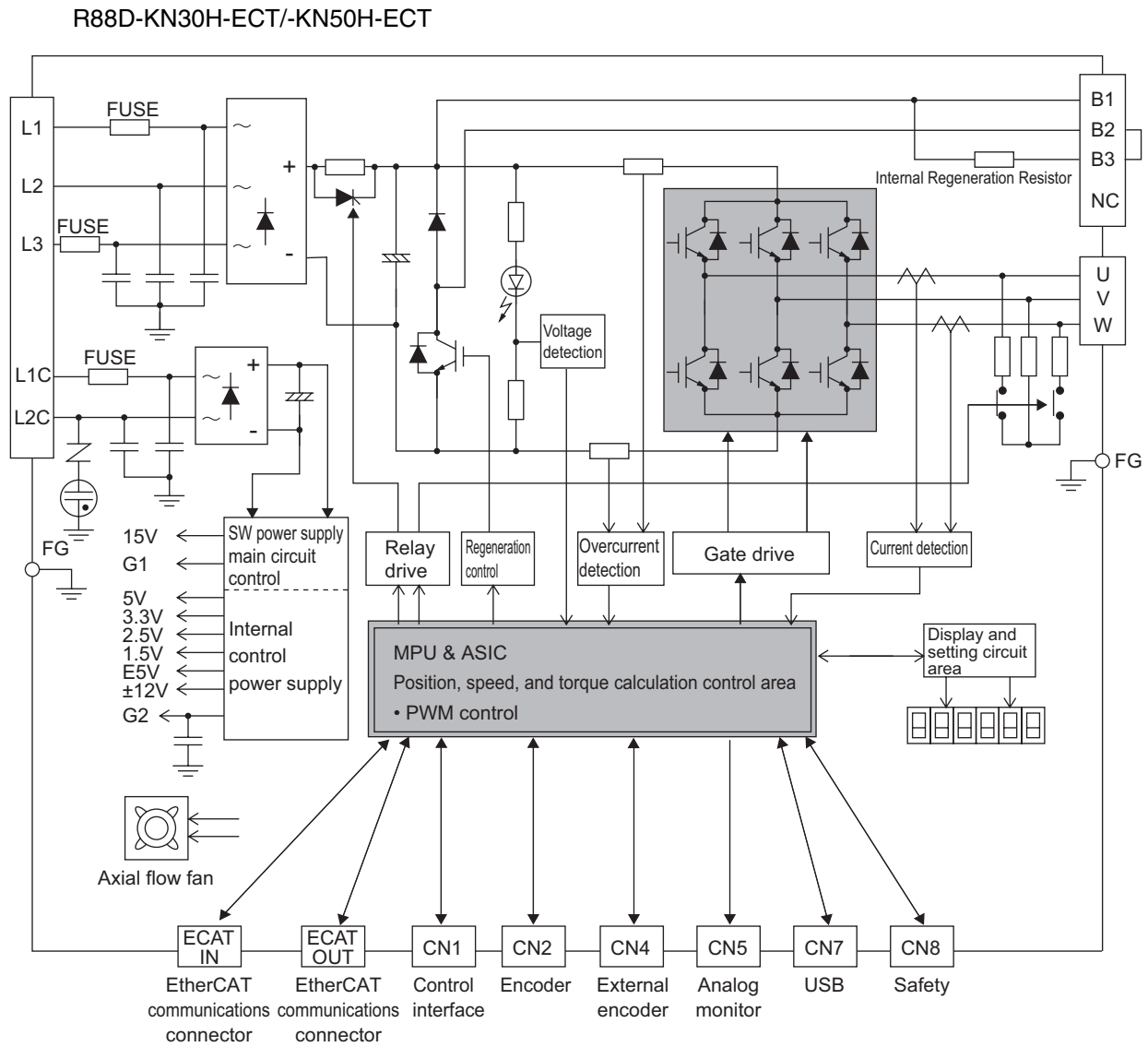

R88D-KN75H-ECT

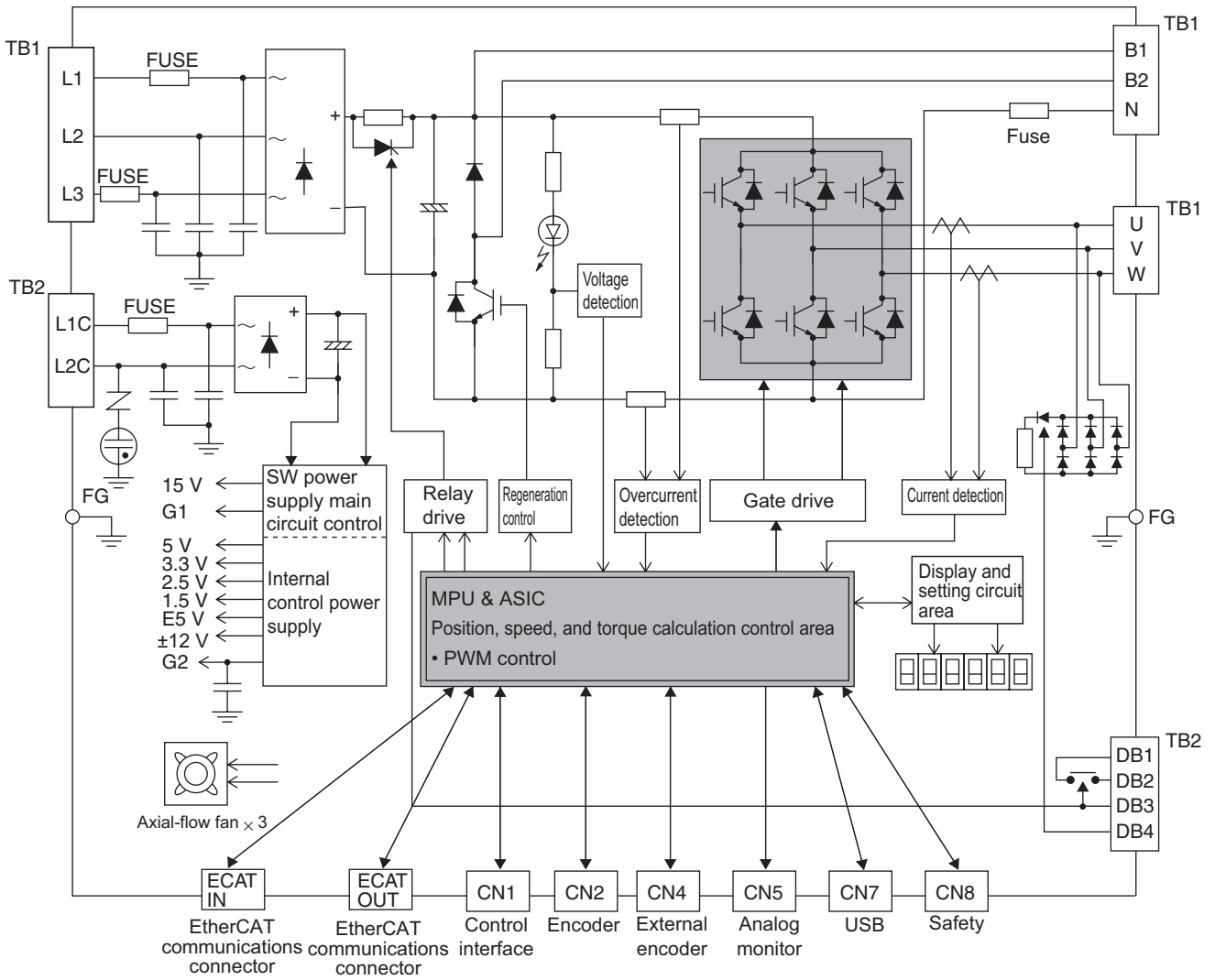

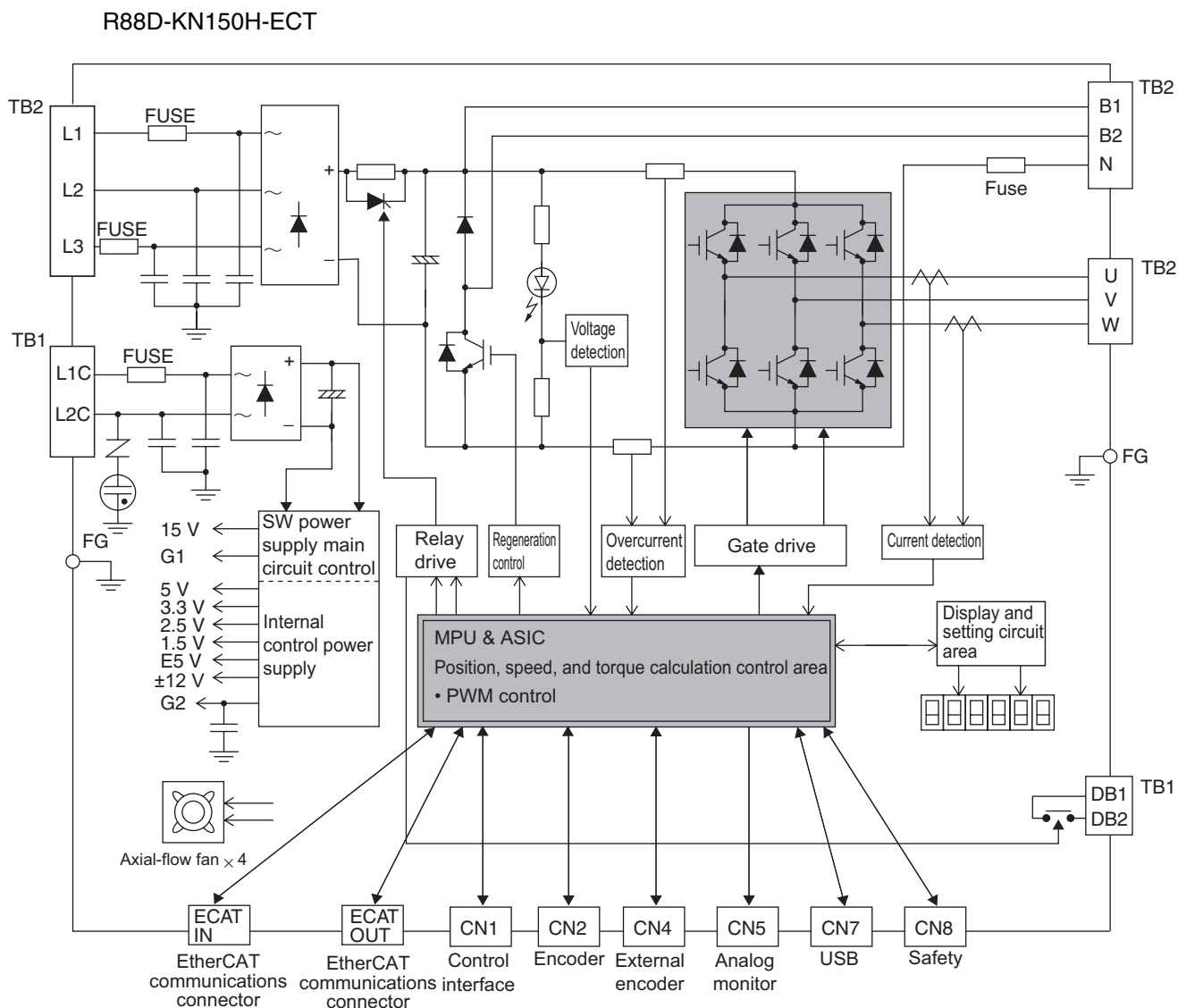

R88D-KN06F-ECT/-KN10F-ECT/-KN15F-ECT/-KN20F-ECT

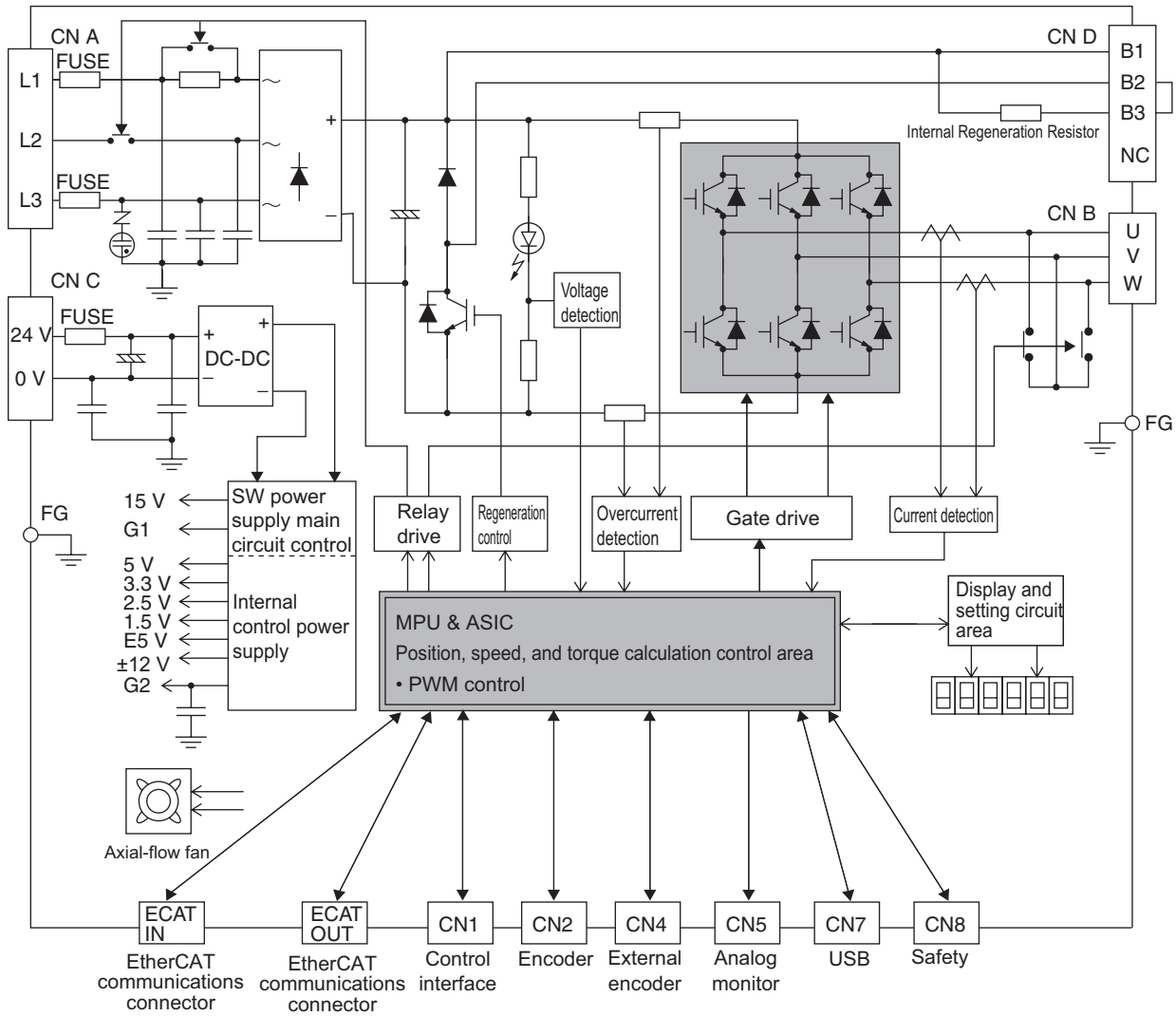

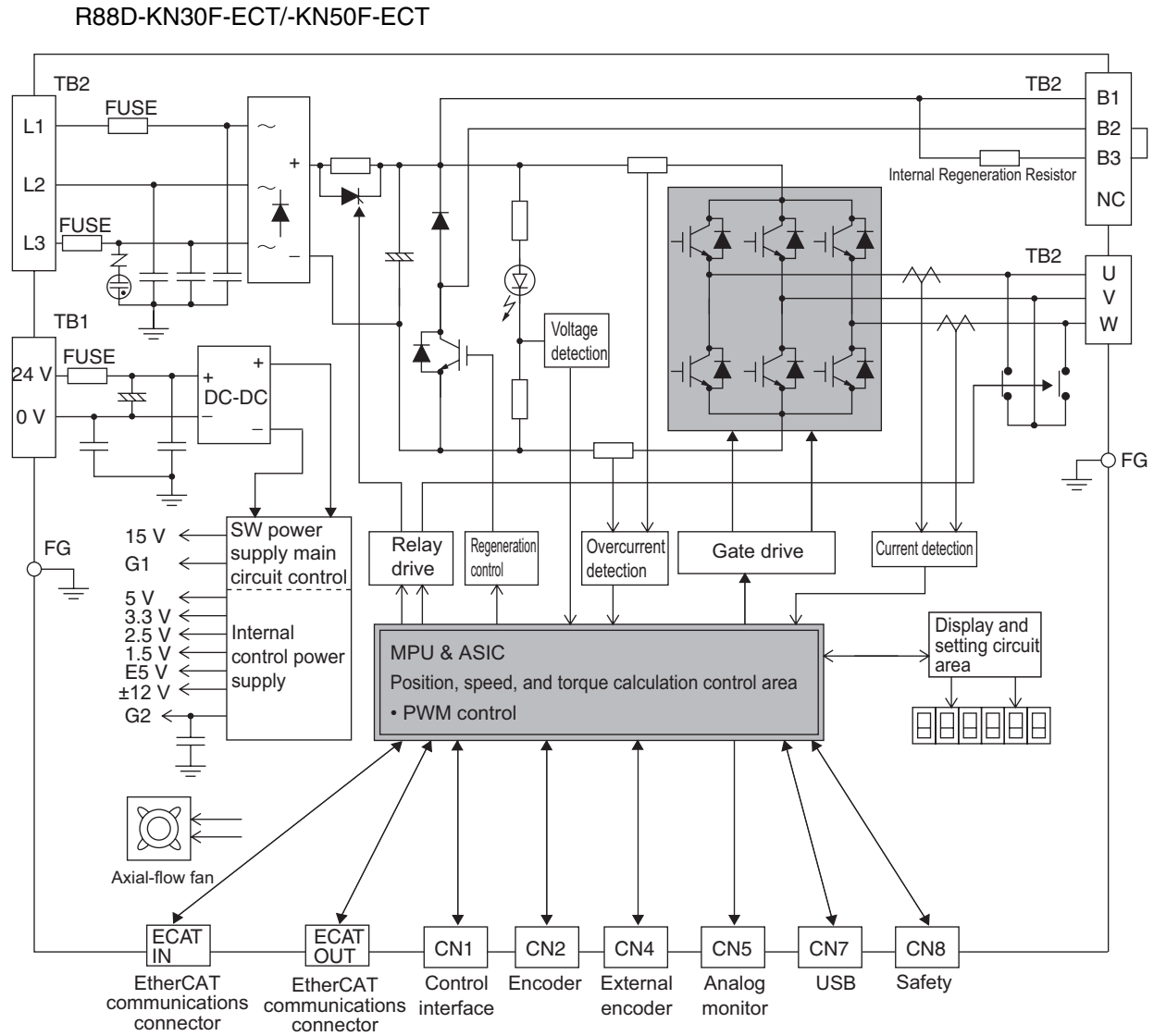

R88D-KN75F-ECT

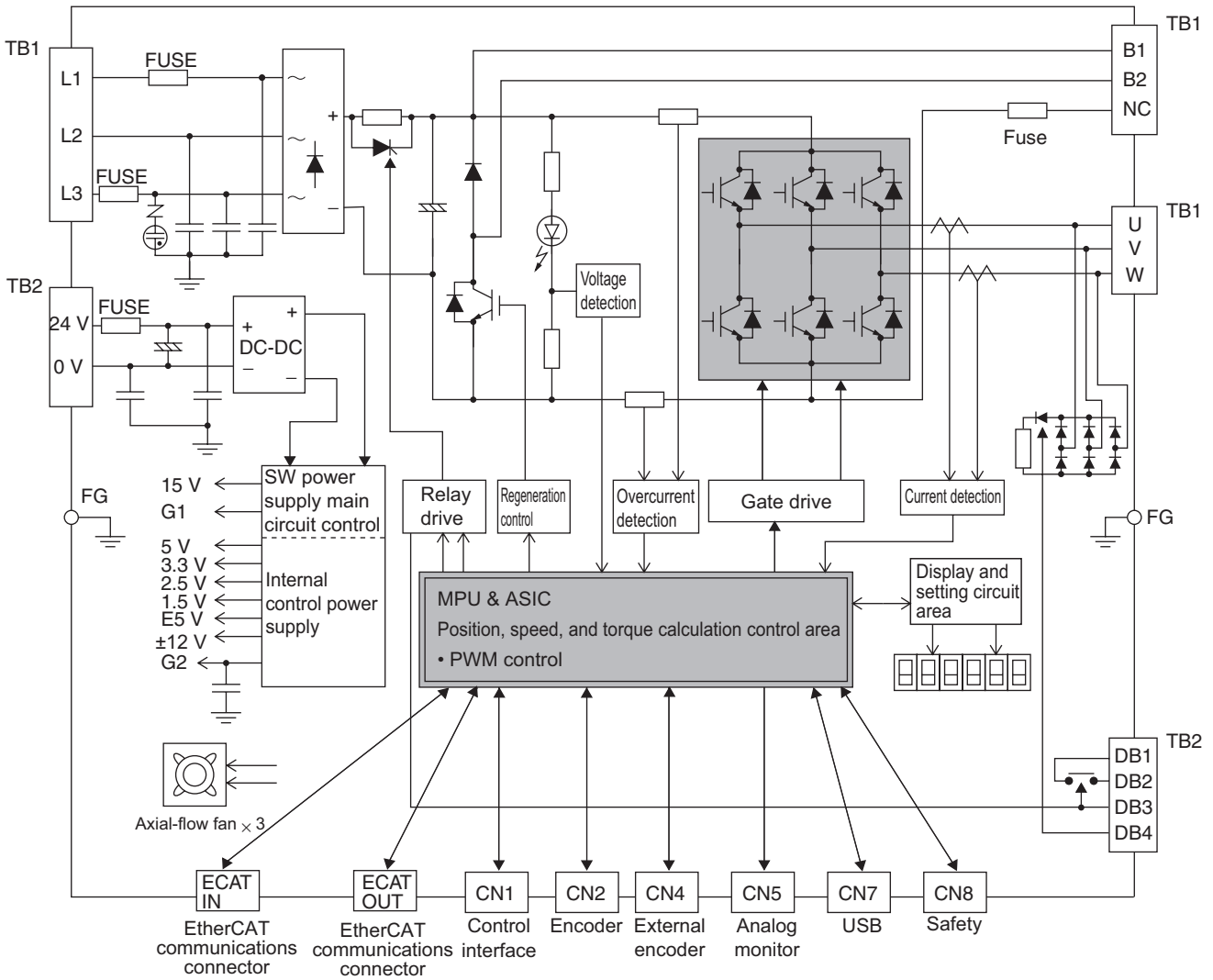

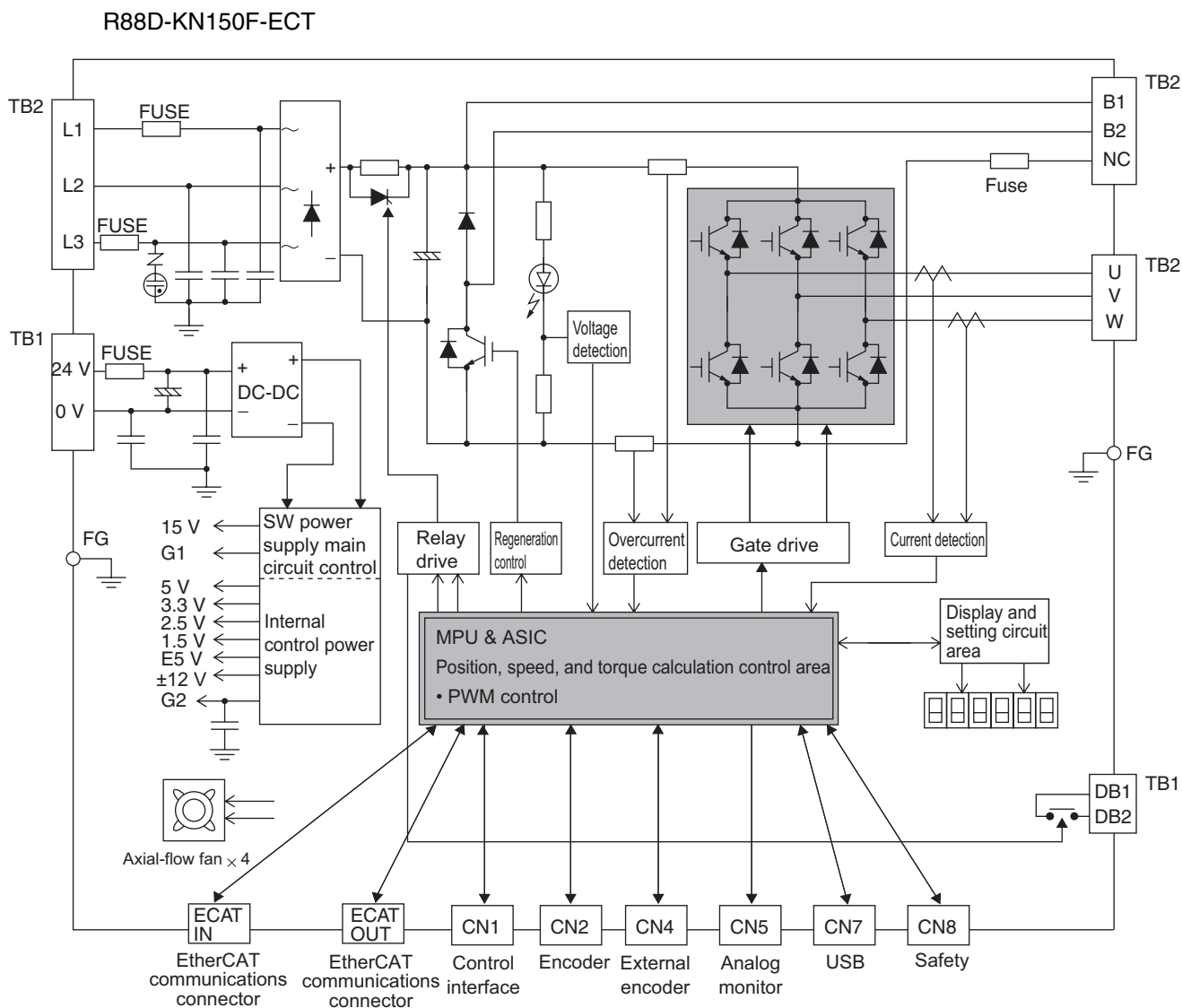

1-5 Applicable Standards

This section describes applicable EMC Directives.

1-5-1 EC Directives

EC Directive	Product	Applicable standards
Low Voltage Directive	AC Servo Drives	EN 61800-5-1
	AC Servomotors	EN 60034-1/-5
EMC Directive	AC Servo Drives	EN 55011 class A group 1
		IEC 61800-3
		EN 61000-6-2
Machinery Directive	AC Servo Drives	EN 954-1 (Category 3) EN ISO 13849-1: 2008 (Category 3) (PLc, d) ISO 13849-1: 2006 (Category 3) (PLc, d) EN 61508 (SIL 2) EN 62061 (SIL 2) EN 61800-5-2 (STO) IEC 61326-3-1 (SIL 2)

Note To conform to EMC Directives, the Servomotor and Servo Drive must be installed under the conditions described in *4-3 Wiring Conforming to EMC Directives* on page 4-35.

1-5-2 UL and cUL Standards

Standard	Product	Applicable standards	File number
UL standards	AC Servo Drives	UL 508C	E179149
	AC Servomotors	UL 1004-1	E331224
		UL 1004-1, UL 1004-6	E331224* ¹
CSA standards	AC Servo Drives	CSA 22.2 No. 14	E179149
	AC Servomotors	CSA 22.2 No. 100	E331224
		CSA 22.2 No. 100	E331224* ¹

*1 Applies to 1,500-r/min Servomotors of 7.5 to 15 kW and 1,000-r/min Servomotors of 4.5 to 6 kW.

The Servo Drives and Servomotors comply with UL 508C (file No. E179149) as long as the following installation conditions 1 and 2 are met.

- (1) Use the Servo Drive in a pollution degree 1 or 2 environment as defined in IEC 60664-1 (example: installation in an IP54 control panel).
- (2) Be sure to connect a circuit breaker or fuse, which is a UL-listed product with LISTED and  mark, between the power supply and noise filter. Refer to the following table for the rated current of the circuit breaker or fuse. Use copper wiring with a temperature rating of 75°C or higher.

Servo Drive model	Rated current of circuit breaker (A)
R88D-KNA5L-ECT	10
R88D-KN01L-ECT	10
R88D-KN02L-ECT	10
R88D-KN04L-ECT	10
R88D-KN01H-ECT	10
R88D-KN02H-ECT	10
R88D-KN04H-ECT	10
R88D-KN08H-ECT	15
R88D-KN10H-ECT	15
R88D-KN15H-ECT	20
R88D-KN20H-ECT	30
R88D-KN30H-ECT	50
R88D-KN50H-ECT	50
R88D-KN75H-ECT	60
R88D-KN150H-ECT	100/125 * ¹
R88D-KN06F-ECT	15
R88D-KN10F-ECT	15
R88D-KN15F-ECT	15
R88D-KN20F-ECT	20
R88D-KN30F-ECT	30
R88D-KN50F-ECT	30
R88D-KN75F-ECT	30
R88D-KN150F-ECT	50/60 * ²

*1 For the use in combination with the Servomotor (Model: R88M-K11K015T-□, the rated current is 100 A, and for R88M-K15K015T-□, it is 125 A.

*2 For the use in combination with the Servomotor (Model: R88M-K11K015C-□), the rated current is 50 A and for R88M-K15K015C-□, it is 60 A.

1-5-3 Korean Radio Regulations (KC)

- G5-series Servo Drives comply with the Korean Radio Regulations (KC).
- G5-series Servomotors is exempt from the Korean Radio Regulations (KC).

1-5-4 SEMI F47

- Some Servo Drives conform to the SEMI F47 standard for momentary power interruptions (voltage sag immunity) for no-load or light-load operation.
- This standard applies to semiconductor manufacturing equipment.

Note 1 It does not apply to Servo Drivers with single-phase 100-V specifications or with 24-VDC specifications for the control power input.

2 Always perform evaluation testing for SEMI F47 compliance in the actual system.

1-6 Unit Versions

The G5-series Servo Drive uses unit versions. Unit versions are used to manage differences in supported functions when product upgrades are made.

1-6-1 Confirmation Method

The unit version of a G5-series Servo Drive is given on the product's nameplate as shown below.

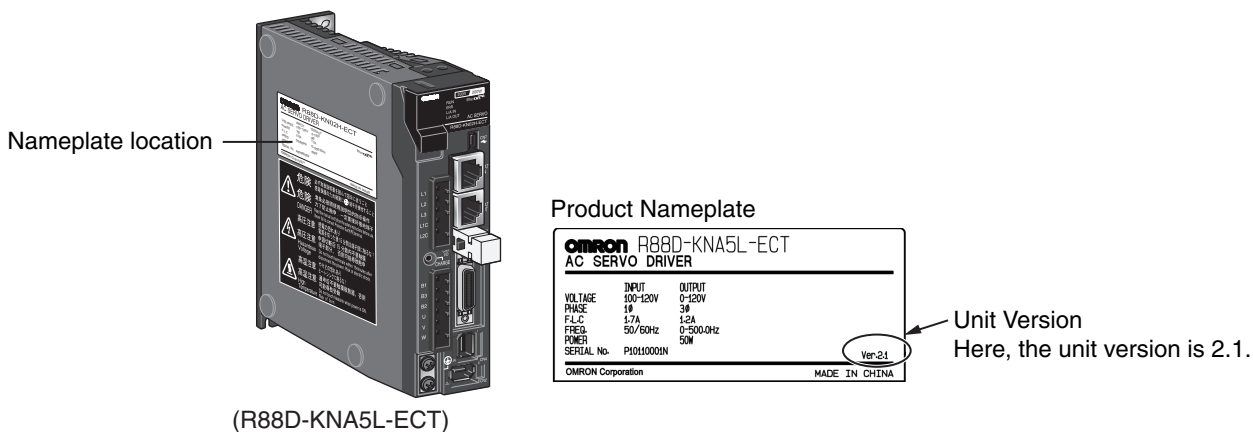

1-6-2 Unit Versions

Unit version	Upgraded content*1	Supported CX-Drive versions
Ver. 1.0	New release	Ver. 1.92 or higher
Ver. 2.0	Function added, including support for csv, cst, and hm modes.	Ver. 2.20 or higher
Ver. 2.1	Functions added to support operation as a Sysmac device and for pp mode.	Ver. 2.40 or higher

*1 Refer to A-5 Functional Differences among Unit Versions on page A-169 for details.

2

Models and External Dimensions

This chapter explains the models of Servo Drive, Servomotor, and peripheral devices, and provides the external dimensions and mounting dimensions.

2-1	Servo System Configuration	2-2
2-2	How to Read Model Numbers	2-4
2-2-1	Servo Drive	2-4
2-2-2	Servomotors	2-5
2-2-3	Reduction Gear (3 Arcminutes Max.)	2-6
2-2-4	Reduction Gear (15 Arcminutes Max.)	2-7
2-3	Model Tables	2-8
2-3-1	Servo Drive Model Table	2-8
2-3-2	Servomotor Model Tables	2-9
2-3-3	Servo Drive and Servomotor Combination Tables	2-14
2-3-4	Reduction Gear Model Tables	2-16
2-3-5	Cable and Peripheral Device Model Tables	2-20
2-4	External and Mounting Dimensions	2-28
2-4-1	Servo Drive Dimensions	2-28
2-4-2	Servomotor Dimensions	2-44
2-4-3	Combinations of Servomotors and Reduction Gears	2-70
2-4-4	Reduction Gear Dimensions	2-72
2-4-5	External Regeneration Resistor Dimensions	2-86
2-4-6	Reactor Dimensions	2-87

2-1 Servo System Configuration

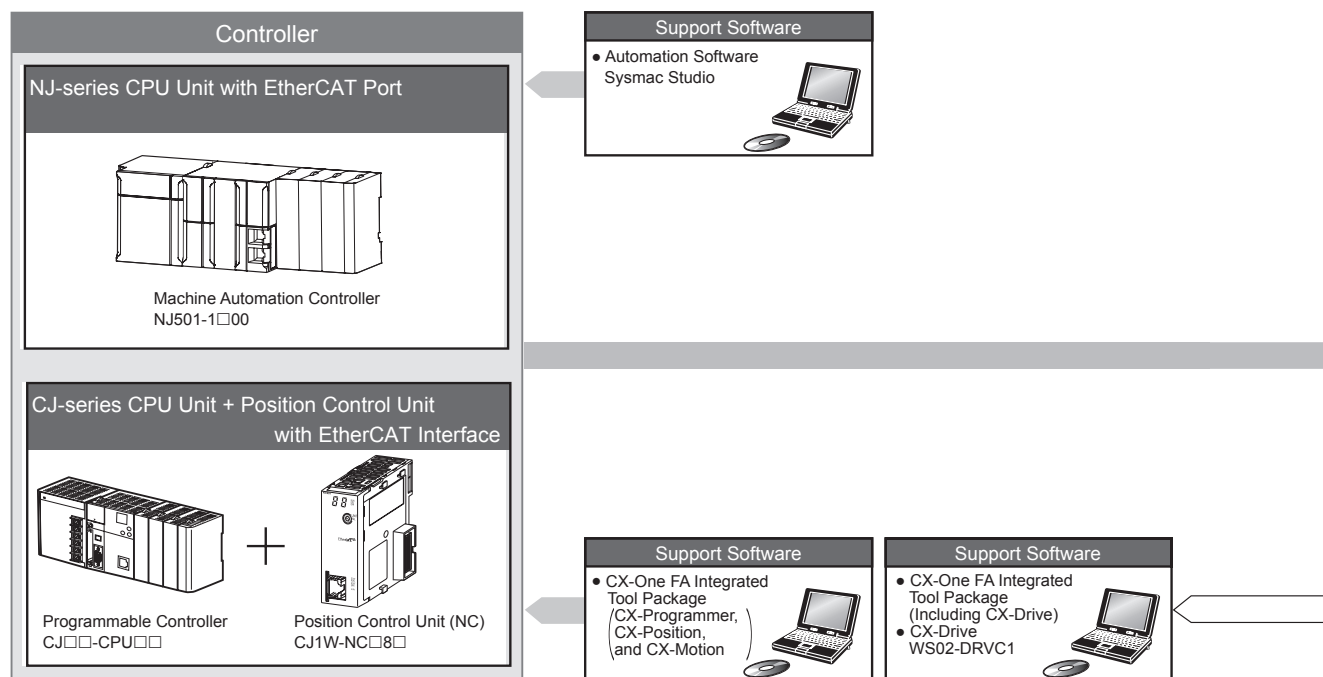

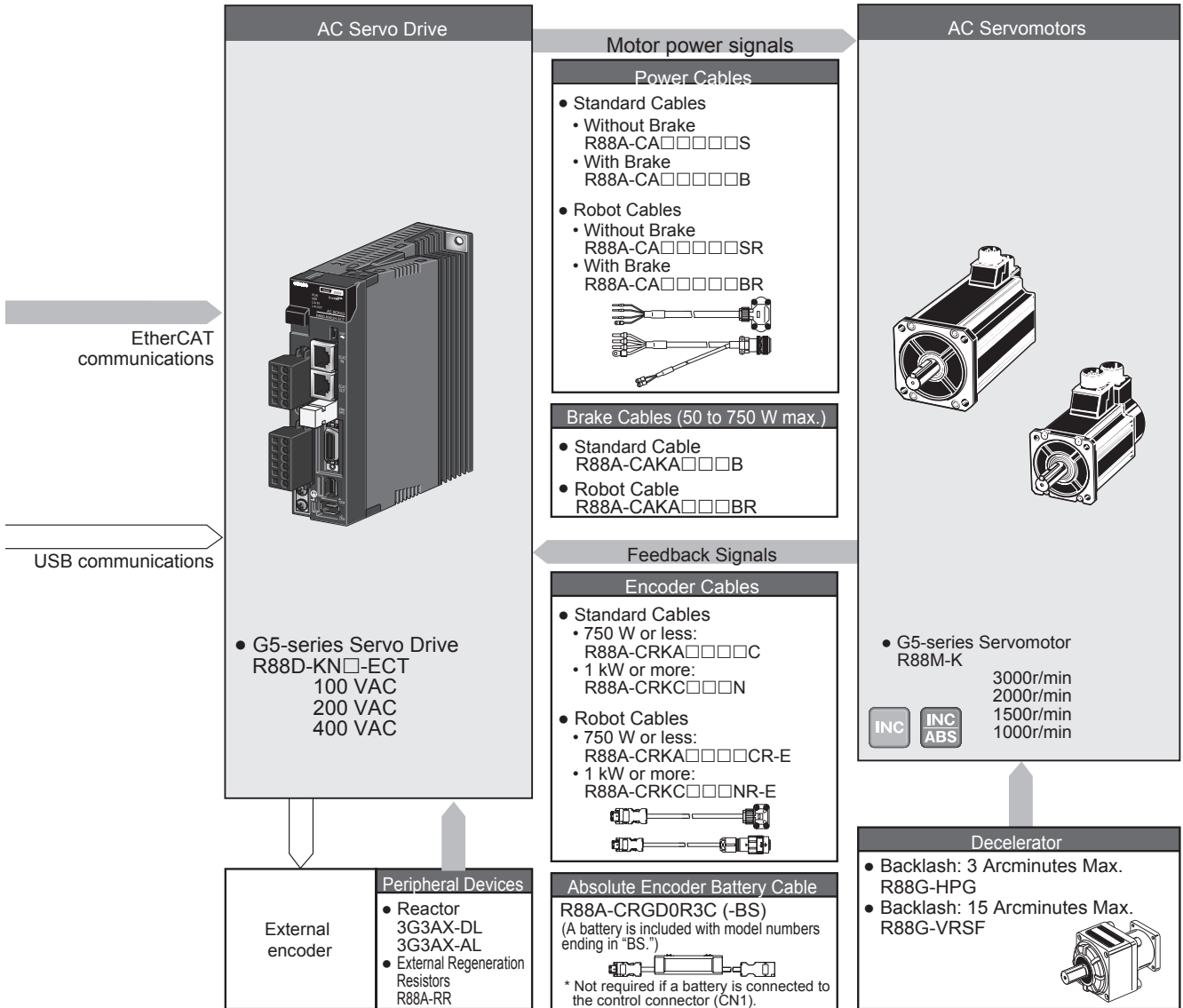

2-2 How to Read Model Numbers

This section describes how to read and understand the model numbers of Servo Drives and Servomotors.

2-2-1 Servo Drive

The Servo Drive model number tells the Servo Drive type, applicable Servomotor capacity, power supply voltage, etc.

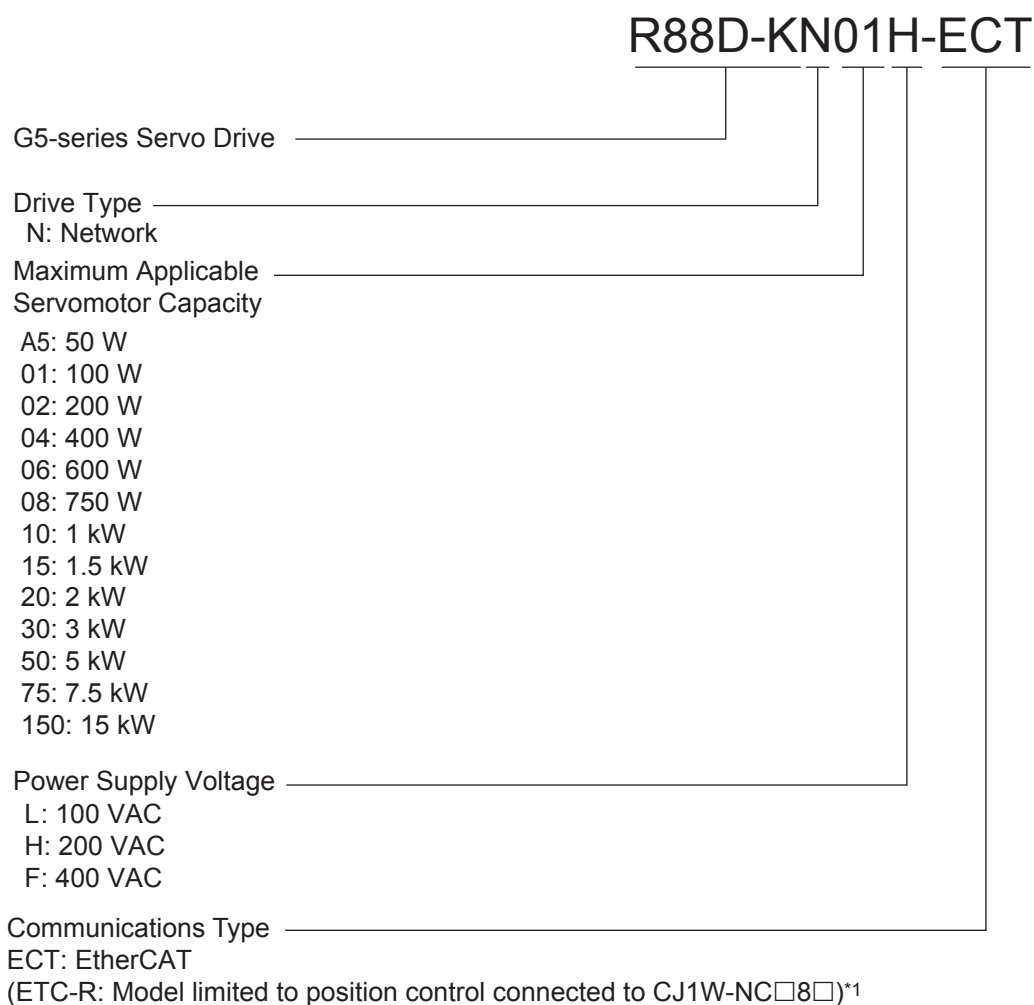

*1 This manual is for the R88D-KN□□□-ECT Servo Drives.
For details on the R88D-KN□□□-ECT-R Servo Drives, refer to *G5 Series AC Servomotors/Servo Drives with Built-in EtherCAT Communications* (Cat. No. I573).

2-2-2 Servomotors

The model number provides information such as the Servomotor type, motor capacity, rated rotation speed, and power supply voltage.

R88M-KP10030H-BOS2

G5-series Servomotor

Motor Type

Blank: Cylinder type

Servomotor Capacity

- 050: 50 W
- 100: 100 W
- 200: 200 W
- 400: 400 W
- 600: 600 W
- 750: 750 W
- 900: 900 W
- 1K0: 1 kW
- 1K5: 1.5 kW
- 2K0: 2 kW
- 3K0: 3 kW
- 4K0: 4 kW
- 4K5: 4.5 kW
- 5K0: 5 kW
- 6K0: 6 kW
- 7K5: 7.5 kW
- 11K0: 11 kW
- 15K0: 15 kW

Rated Rotation Speed

- 10: 1,000 r/min
- 15: 1,500 r/min
- 20: 2,000 r/min
- 30: 3,000 r/min

Applied Voltage

- F: 400 VAC (incremental encoder)
- H: 200 VAC (incremental encoder)
- L: 100 VAC (incremental encoder)
- C: 400 VAC (absolute encoder)
- T: 200 VAC (absolute encoder)
- S: 100 VAC (absolute encoder)

Options

- No: Straight shaft
- B: With brake
- O: With oil seal
- S2: With key and tap

2-2-3 Reduction Gear (3 Arcminutes Max.)

The model number provides information such as the reduction gear, flange size number, reduction ratio, applicable Servomotor, Servomotor type, and backlash.

R88G-HPG14A05100SBJ

For G5-series Servomotor

Reduction Gear

3 Arcminutes Max.

Flange Size Number

11B: □40

14A: □60

20A: □90

32A: □120

50A: □170

65A: □230

Reduction Ratio

05: 1/5

09: 1/9 (only for 11B flange)

11: 1/11 (except for 65A flange)

12: 1/12 (only for 65A flange)

20: 1/20 (only for 65A flange)

21: 1/21 (except for 65A flange)

25: 1/25 (only for 65A flange)

33: 1/33

45: 1/45

Applicable Servomotor Capacity

050: 50 W

100: 100 W

200: 200 W

400: 400 W

750: 750 W

900: 900 W

1K0: 1k W

1K5: 1.5 kW

2K0: 2 kW

3K0: 3 kW

4K0: 4 kW

4K5: 4.5 kW

5K0: 5 kW

Servomotor Type

No: Cylinder type (3,000 r/min)

S: 1500r/min Servomotors, 2000r/min Servomotors

T: 1000r/min Servomotors

Backlash

B: 3 Arcminutes Max.

Options

No: Straight shaft

J: With key

2-2-4 Reduction Gear (15 Arcminutes Max.)

The model number provides information such as the reduction gear, flange size number, reduction ratio, applicable Servomotor, Servomotor type, and backlash.

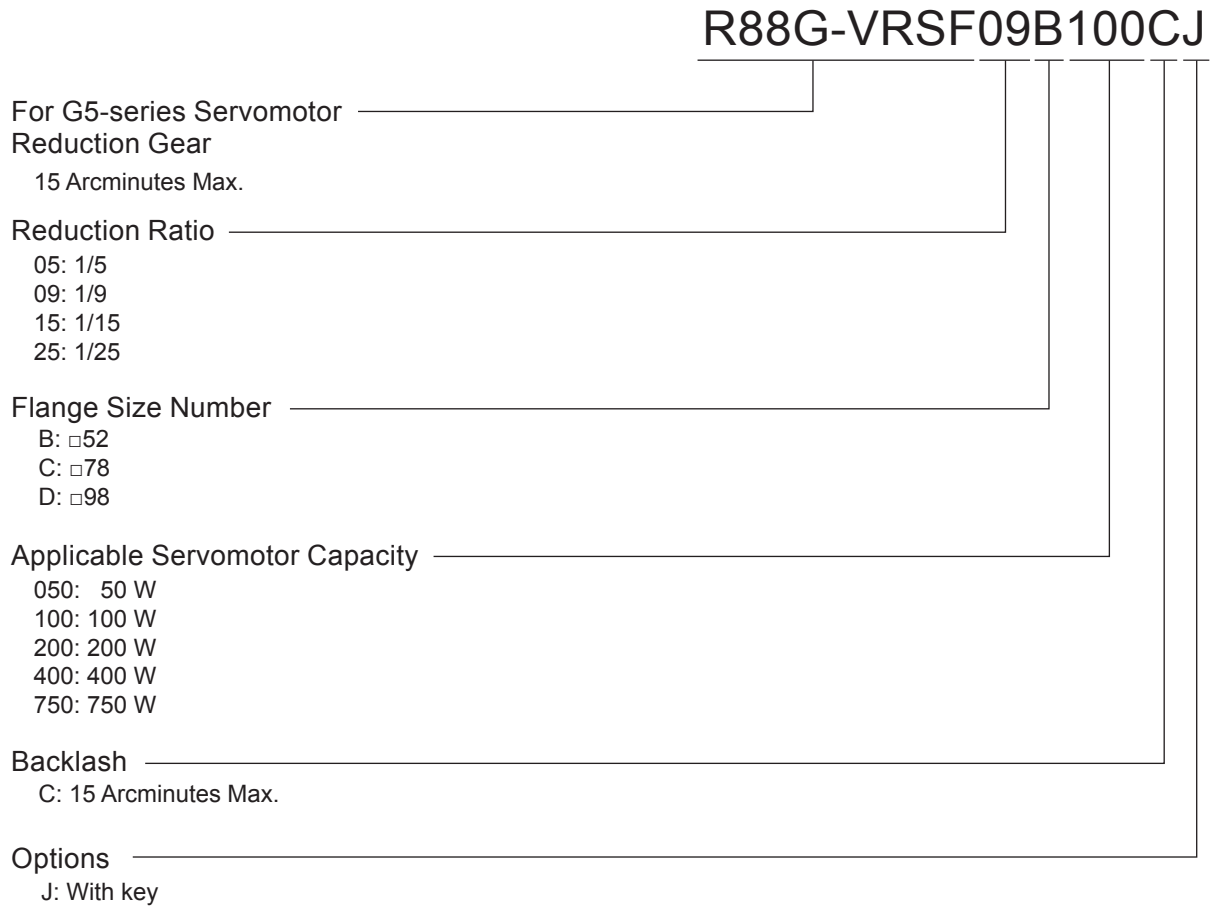

2-3 Model Tables

This section lists the standard models of Servo Drives, Servomotors, Cables, Connectors, and peripheral equipment.

2-3-1 Servo Drive Model Table

The table below lists the Servo Drive models.

Specifications		Model
Single-phase 100 VAC	50 W	R88D-KNA5L-ECT
	100 W	R88D-KN01L-ECT
	200 W	R88D-KN02L-ECT
	400 W	R88D-KN04L-ECT
Single-phase/3-phase 200 VAC	100 W	R88D-KN01H-ECT
	200 W	R88D-KN02H-ECT
	400 W	R88D-KN04H-ECT
	750 W	R88D-KN08H-ECT
	1 kW	R88D-KN10H-ECT
	1.5 kW	R88D-KN15H-ECT
3-phase 200 VAC	2 kW	R88D-KN20H-ECT
	3 kW	R88D-KN30H-ECT
	5 kW	R88D-KN50H-ECT
	7.5 kW	R88D-KN75H-ECT
	15 kW	R88D-KN150H-ECT
3-phase 400 VAC	600 W	R88D-KN06F-ECT
	1 kW	R88D-KN10F-ECT
	1.5 kW	R88D-KN15F-ECT
	2 kW	R88D-KN20F-ECT
	3 kW	R88D-KN30F-ECT
	5 kW	R88D-KN50F-ECT
	7.5 kW	R88D-KN75F-ECT
	15 kW	R88D-KN150F-ECT

2-3-2 Servomotor Model Tables

The following tables list the Servomotor models by the rated motor speed.

3,000-r/min Servomotors

Specifications		Model				
		With incremental encoder		With absolute encoder		
		Straight shaft without key	Straight shaft with key and tap	Straight shaft without key	Straight shaft with key and tap	
Without brakes	100 V	50 W	R88M-K05030H	R88M-K05030H-S2	R88M-K05030T	R88M-K05030T-S2
		100 W	R88M-K10030L	R88M-K10030L-S2	R88M-K10030S	R88M-K10030S-S2
		200 W	R88M-K20030L	R88M-K20030L-S2	R88M-K20030S	R88M-K20030S-S2
		400 W	R88M-K40030L	R88M-K40030L-S2	R88M-K40030S	R88M-K40030S-S2
	200 V	50 W	R88M-K05030H	R88M-K05030H-S2	R88M-K05030T	R88M-K05030T-S2
		100 W	R88M-K10030H	R88M-K10030H-S2	R88M-K10030T	R88M-K10030T-S2
		200 W	R88M-K20030H	R88M-K20030H-S2	R88M-K20030T	R88M-K20030T-S2
		400 W	R88M-K40030H	R88M-K40030H-S2	R88M-K40030T	R88M-K40030T-S2
		750 W	R88M-K75030H	R88M-K75030H-S2	R88M-K75030T	R88M-K75030T-S2
		1 kW	R88M-K1K030H	R88M-K1K030H-S2	R88M-K1K030T	R88M-K1K030T-S2
		1.5 kW	R88M-K1K530H	R88M-K1K530H-S2	R88M-K1K530T	R88M-K1K530T-S2
		2 kW	R88M-K2K030H	R88M-K2K030H-S2	R88M-K2K030T	R88M-K2K030T-S2
		3 kW	R88M-K3K030H	R88M-K3K030H-S2	R88M-K3K030T	R88M-K3K030T-S2
		4 kW	R88M-K4K030H	R88M-K4K030H-S2	R88M-K4K030T	R88M-K4K030T-S2
	5 kW	R88M-K5K030H	R88M-K5K030H-S2	R88M-K5K030T	R88M-K5K030T-S2	
	400 V	750 W	R88M-K75030F	R88M-K75030F-S2	R88M-K75030C	R88M-K75030C-S2
		1 kW	R88M-K1K030F	R88M-K1K030F-S2	R88M-K1K030C	R88M-K1K030C-S2
		1.5 kW	R88M-K1K530F	R88M-K1K530F-S2	R88M-K1K530C	R88M-K1K530C-S2
		2 kW	R88M-K2K030F	R88M-K2K030F-S2	R88M-K2K030C	R88M-K2K030C-S2
		3 kW	R88M-K3K030F	R88M-K3K030F-S2	R88M-K3K030C	R88M-K3K030C-S2
		4 kW	R88M-K4K030F	R88M-K4K030F-S2	R88M-K4K030C	R88M-K4K030C-S2
	5 kW	R88M-K5K030F	R88M-K5K030F-S2	R88M-K5K030C	R88M-K5K030C-S2	

Note Models with oil seals are also available.

Specifications		Model				
		With incremental encoder		With absolute encoder		
		Straight shaft without key	Straight shaft with key and tap	Straight shaft without key	Straight shaft with key and tap	
With brakes	100 V	50 W	R88M-K05030H-B	R88M-K05030H-BS2	R88M-K05030T-B	R88M-K05030T-BS2
		100 W	R88M-K10030L-B	R88M-K10030L-BS2	R88M-K10030S-B	R88M-K10030S-BS2
		200 W	R88M-K20030L-B	R88M-K20030L-BS2	R88M-K20030S-B	R88M-K20030S-BS2
		400 W	R88M-K40030L-B	R88M-K40030L-BS2	R88M-K40030S-B	R88M-K40030S-BS2
	200 V	50 W	R88M-K05030H-B	R88M-K05030H-BS2	R88M-K05030T-B	R88M-K05030T-BS2
		100 W	R88M-K10030H-B	R88M-K10030H-BS2	R88M-K10030T-B	R88M-K10030T-BS2
		200 W	R88M-K20030H-B	R88M-K20030H-BS2	R88M-K20030T-B	R88M-K20030T-BS2
		400 W	R88M-K40030H-B	R88M-K40030H-BS2	R88M-K40030T-B	R88M-K40030T-BS2
		750 W	R88M-K75030H-B	R88M-K75030H-BS2	R88M-K75030T-B	R88M-K75030T-BS2
		1 kW	R88M-K1K030H-B	R88M-K1K030H-BS2	R88M-K1K030T-B	R88M-K1K030T-BS2
		1.5 kW	R88M-K1K530H-B	R88M-K1K530H-BS2	R88M-K1K530T-B	R88M-K1K530T-BS2
		2 kW	R88M-K2K030H-B	R88M-K2K030H-BS2	R88M-K2K030T-B	R88M-K2K030T-BS2
		3 kW	R88M-K3K030H-B	R88M-K3K030H-BS2	R88M-K3K030T-B	R88M-K3K030T-BS2
		4 kW	R88M-K4K030H-B	R88M-K4K030H-BS2	R88M-K4K030T-B	R88M-K4K030T-BS2
		5 kW	R88M-K5K030H-B	R88M-K5K030H-BS2	R88M-K5K030T-B	R88M-K5K030T-BS2
	400 V	750 W	R88M-K75030F-B	R88M-K75030F-BS2	R88M-K75030C-B	R88M-K75030C-BS2
		1 kW	R88M-K1K030F-B	R88M-K1K030F-BS2	R88M-K1K030C-B	R88M-K1K030C-BS2
		1.5 kW	R88M-K1K530F-B	R88M-K1K530F-BS2	R88M-K1K530C-B	R88M-K1K530C-BS2
		2 kW	R88M-K2K030F-B	R88M-K2K030F-BS2	R88M-K2K030C-B	R88M-K2K030C-BS2
		3 kW	R88M-K3K030F-B	R88M-K3K030F-BS2	R88M-K3K030C-B	R88M-K3K030C-BS2
		5 kW	R88M-K5K030F-B	R88M-K5K030F-BS2	R88M-K5K030C-B	R88M-K5K030C-BS2

Note Models with oil seals are also available.

1,500-r/min and 2,000-r/min Servomotors

Specifications		Model				
		With incremental encoder		With absolute encoder		
		Straight shaft without key	Straight shaft with key and tap	Straight shaft without key	Straight shaft with key and tap	
Without brakes	200 V	1 kW	R88M-K1K020H	R88M-K1K020H-S2	R88M-K1K020T	R88M-K1K020T-S2
		1.5 kW	R88M-K1K520H	R88M-K1K520H-S2	R88M-K1K520T	R88M-K1K520T-S2
		2 kW	R88M-K2K020H	R88M-K2K020H-S2	R88M-K2K020T	R88M-K2K020T-S2
		3 kW	R88M-K3K020H	R88M-K3K020H-S2	R88M-K3K020T	R88M-K3K020T-S2
		4 kW	R88M-K4K020H	R88M-K4K020H-S2	R88M-K4K020T	R88M-K4K020T-S2
		5 kW	R88M-K5K020H	R88M-K5K020H-S2	R88M-K5K020T	R88M-K5K020T-S2
		7.5 kW	–	–	R88M-K7K515T	R88M-K7K515T-S2
		11 kW	–	–	R88M-K11K015T	R88M-K11K015T-S2
		15 kW	–	–	R88M-K15K015T	R88M-K15K015T-S2
	400 V	400 W	R88M-K40020F	R88M-K40020F-S2	R88M-K40020C	R88M-K40020C-BS2
		600 W	R88M-K60020F	R88M-K60020F-S2	R88M-K60020C	R88M-K60020C-BS2
		1 kW	R88M-K1K020F	R88M-K1K020F-S2	R88M-K1K020C	R88M-K1K020C-S2
		1.5 kW	R88M-K1K520F	R88M-K1K520F-S2	R88M-K1K520C	R88M-K1K520C-S2
		2 kW	R88M-K2K020F	R88M-K2K020F-S2	R88M-K2K020C	R88M-K2K020C-S2
		3 kW	R88M-K3K020F	R88M-K3K020F-S2	R88M-K3K020C	R88M-K3K020C-S2
		4 kW	R88M-K4K020F	R88M-K4K020F-S2	R88M-K4K020C	R88M-K4K020C-S2
		5 kW	R88M-K5K020F	R88M-K5K020F-S2	R88M-K5K020C	R88M-K5K020C-S2
		7.5 kW	–	–	R88M-K7K515C	R88M-K7K515C-S2
		11 kW	–	–	R88M-K11K015C	R88M-K11K015C-S2
		15 kW	–	–	R88M-K15K015C	R88M-K15K015C-S2

Note 1 Models with oil seals are also available.

2 The rated rotation speed of Servomotors of 7.5 to 15 kW is 1,500 r/min.

Specifications		Model				
		With incremental encoder		With absolute encoder		
		Straight shaft without key	Straight shaft with key and tap	Straight shaft without key	Straight shaft with key and tap	
With brakes	200 V	1 kW	R88M-K1K020H-B	R88M-K1K020H-BS2	R88M-K1K020T-B	R88M-K1K020T-BS2
		1.5 kW	R88M-K1K520H-B	R88M-K1K520H-BS2	R88M-K1K520T-B	R88M-K1K520T-BS2
		2 kW	R88M-K2K020H-B	R88M-K2K020H-BS2	R88M-K2K020T-B	R88M-K2K020T-BS2
		3 kW	R88M-K3K020H-B	R88M-K3K020H-BS2	R88M-K3K020T-B	R88M-K3K020T-BS2
		4 kW	R88M-K4K020H-B	R88M-K4K020H-BS2	R88M-K4K020T-B	R88M-K4K020T-BS2
		5 kW	R88M-K5K020H-B	R88M-K5K020H-BS2	R88M-K5K020T-B	R88M-K5K020T-BS2
		7.5 kW	–	–	R88M-K7K515T-B	R88M-K7K515T-BS2
		11 kW	–	–	R88M-K11K015T-B	R88M-K11K015T-BS2
	15 kW	–	–	R88M-K15K015T-B	R88M-K15K015T-BS2	
	400 V	400 W	R88M-K40020F-B	R88M-K40020F-BS2	R88M-K40020C-B	R88M-K40020C-BS2
		600 W	R88M-K60020F-B	R88M-K60020F-BS2	R88M-K60020C-B	R88M-K60020C-BS2
		1 kW	R88M-K1K020F-B	R88M-K1K020F-BS2	R88M-K1K020C-B	R88M-K1K020C-BS2
		1.5 kW	R88M-K1K520F-B	R88M-K1K520F-BS2	R88M-K1K520C-B	R88M-K1K520C-BS2
		2 kW	R88M-K2K020F-B	R88M-K2K020F-BS2	R88M-K2K020C-B	R88M-K2K020C-BS2
		3 kW	R88M-K3K020F-B	R88M-K3K020F-BS2	R88M-K3K020C-B	R88M-K3K020C-BS2
		4 kW	R88M-K4K020F-B	R88M-K4K020F-BS2	R88M-K4K020C-B	R88M-K4K020C-BS2
		5 kW	R88M-K5K020F-B	R88M-K5K020F-BS2	R88M-K5K020C-B	R88M-K5K020C-BS2
		7.5 kW	–	–	R88M-K7K515C-B	R88M-K7K515C-BS2
		11 kW	–	–	R88M-K11K015C-B	R88M-K11K015C-BS2
15 kW		–	–	R88M-K15K015C-B	R88M-K15K015C-BS2	

Note 1 Models with oil seals are also available.

2 The rated rotation speed of Servomotors of 7.5 to 15 kW is 1,500 r/min.

1,000-r/min Servomotors

Specifications		Model				
		With incremental encoder		With absolute encoder		
		Straight shaft without key	Straight shaft with key and tap	Straight shaft without key	Straight shaft with key and tap	
Without brakes	200 V	900 kW	R88M-K90010H	R88M-K90010H-S2	R88M-K90010T	R88M-K90010T-S2
		2 kW	R88M-K2K010H	R88M-K2K010H-S2	R88M-K2K010T	R88M-K2K010T-S2
		3 kW	R88M-K3K010H	R88M-K3K010H-S2	R88M-K3K010T	R88M-K3K010T-S2
		4.5 kW	–	–	R88M-K4K510T	R88M-K4K510T-S2
		6 kW	–	–	R88M-K6K010T	R88M-K6K010T-S2
	400 V	900 kW	R88M-K90010F	R88M-K90010F-S2	R88M-K90010C	R88M-K90010C-S2
		2 kW	R88M-K2K010F	R88M-K2K010F-S2	R88M-K2K010C	R88M-K2K010C-S2
		3 kW	R88M-K3K010F	R88M-K3K010F-S2	R88M-K3K010C	R88M-K3K010C-S2
		4.5 kW	–	–	R88M-K4K510C	R88M-K4K510C-S2
		6 kW	–	–	R88M-K6K010C	R88M-K6K010C-S2
With brakes	200 V	900 kW	R88M-K90010H-B	R88M-K90010H-BS2	R88M-K90010T-B	R88M-K90010T-BS2
		2 kW	R88M-K2K010H-B	R88M-K2K010H-BS2	R88M-K2K010T-B	R88M-K2K010T-BS2
		3 kW	R88M-K3K010H-B	R88M-K3K010H-BS2	R88M-K3K010T-B	R88M-K3K010T-BS2
		4.5 kW	–	–	R88M-K4K510T-B	R88M-K4K510T-BS2
		6 kW	–	–	R88M-K6K010T-B	R88M-K6K010T-BS2
	400 V	900 kW	R88M-K90010F-B	R88M-K90010F-BS2	R88M-K90010C-B	R88M-K90010C-BS2
		2 kW	R88M-K2K010F-B	R88M-K2K010F-BS2	R88M-K2K010C-B	R88M-K2K010C-BS2
		3 kW	R88M-K3K010F-B	R88M-K3K010F-BS2	R88M-K3K010C-B	R88M-K3K010C-BS2
		4.5 kW	–	–	R88M-K4K510C-B	R88M-K4K510C-BS2
		6 kW	–	–	R88M-K6K010C-B	R88M-K6K010C-BS2

Note Models with oil seals are also available.

2-3-3 Servo Drive and Servomotor Combination Tables

The tables in this section show the possible combinations of G5-series Servo Drives and Servomotors. The Servomotors and Servo Drives can only be used in the listed combinations.

“□” at the end of the motor model number is for options, such as the shaft type, brake, oil seal and key.

3,000-r/min Servomotors and Servo Drives

Voltage	Servomotor			Servo Drive
	Rated output	With incremental encoder	With absolute encoder	
Single-phase 100 V	50 W	R88M-K05030H-□	R88M-K05030T-□	R88D-KNA5L-ECT
	100 W	R88M-K10030L-□	R88M-K10030S-□	R88D-KN01L-ECT
Single-phase/ 3-phase 100 V	200 W	R88M-K20030L-□	R88M-K20030S-□	R88D-KN02L-ECT
	400 W	R88M-K40030L-□	R88M-K40030S-□	R88D-KN04L-ECT
Single-phase/ 3-phase 200 V	*50 W	R88M-K05030H-□	R88M-K05030T-□	R88D-KN01H-ECT
	100 W	R88M-K10030H-□	R88M-K10030T-□	R88D-KN01H-ECT
	200 W	R88M-K20030H-□	R88M-K20030T-□	R88D-KN02H-ECT
	400 W	R88M-K40030H-□	R88M-K40030T-□	R88D-KN04H-ECT
	750 W	R88M-K75030H-□	R88M-K75030T-□	R88D-KN08H-ECT
	*1 kW	R88M-K1K030H-□	R88M-K1K030T-□	R88D-KN15H-ECT
	1.5 kW	R88M-K1K530H-□	R88M-K1K530T-□	R88D-KN15H-ECT
3-phase 200 V	2 kW	R88M-K2K030H-□	R88M-K2K030T-□	R88D-KN20H-ECT
	3 kW	R88M-K3K030H-□	R88M-K3K030T-□	R88D-KN30H-ECT
	*4 kW	R88M-K4K030H-□	R88M-K4K030T-□	R88D-KN50H-ECT
	5 kW	R88M-K5K030H-□	R88M-K5K030T-□	R88D-KN50H-ECT
3-phase 400 V	*750 W	R88M-K75030F-□	R88M-K75030C-□	R88D-KN10F-ECT
	*1 kW	R88M-K1K030F-□	R88M-K1K030C-□	R88D-KN15F-ECT
	1.5 kW	R88M-K1K530F-□	R88M-K1K530C-□	R88D-KN15F-ECT
	2 kW	R88M-K2K030F-□	R88M-K2K030C-□	R88D-KN20F-ECT
	3 kW	R88M-K3K030F-□	R88M-K3K030C-□	R88D-KN30F-ECT
	*4 kW	R88M-K4K030F-□	R88M-K4K030C-□	R88D-KN50F-ECT
	5 kW	R88M-K5K030F-□	R88M-K5K030C-□	R88D-KN50F-ECT

* Use these combination with caution because the Servo Drive and Servomotor have different capacities.

1,500-r/min and 2,000-r/min Servomotors and Servo Drives

Voltage	Servomotor			Servo Drive
	Rated output	With incremental encoder	With absolute encoder	
Single-phase/ 3-phase 200 V	1 kW	R88M-K1K020H-□	R88M-K1K020T-□	R88D-KN10H-ECT
	1.5 kW	R88M-K1K520H-□	R88M-K1K520T-□	R88D-KN15H-ECT
3-phase 200 V	2 kW	R88M-K2K020H-□	R88M-K2K020T-□	R88D-KN20H-ECT
	3 kW	R88M-K3K020H-□	R88M-K3K020T-□	R88D-KN30H-ECT
	*4 kW	R88M-K4K020H-□	R88M-K4K020T-□	R88D-KN50H-ECT
	5 kW	R88M-K5K020H-□	R88M-K5K020T-□	R88D-KN50H-ECT
	7.5 kW	–	R88M-K7K515T-□	R88D-KN75H-ECT
	*11 kW	–	R88M-K11K015T-□	R88D-KN150H-ECT
	15 kW	–	R88M-K15K015T-□	R88D-KN150H-ECT
	3-phase 400 V	*400 W	R88M-K40020F-□	R88M-K40020C-□
	600 W	R88M-K60020F-□	R88M-K60020C-□	R88D-KN06F-ECT
	1 kW	R88M-K1K020F-□	R88M-K1K020C-□	R88D-KN10F-ECT
	1.5 kW	R88M-K1K520F-□	R88M-K1K520C-□	R88D-KN15F-ECT
	2 kW	R88M-K2K020F-□	R88M-K2K020C-□	R88D-KN20F-ECT
	3 kW	R88M-K3K020F-□	R88M-K3K020C-□	R88D-KN30F-ECT
	*4 kW	R88M-K4K020F-□	R88M-K4K020C-□	R88D-KN50F-ECT
	5 kW	R88M-K5K020F-□	R88M-K5K020C-□	R88D-KN50F-ECT
	7.5 kW	–	R88M-K7K515C-□	R88D-KN75F-ECT
	*11 kW	–	R88M-K11K015C-□	R88D-KN150F-ECT
	15 kW	–	R88M-K15K015C-□	R88D-KN150F-ECT

* Use these combination with caution because the Servo Drive and Servomotor have different capacities.

1,000-r/min Servomotors and Servo Drives

Voltage	Servomotor			Servo Drive
	Rated output	With incremental encoder	With absolute encoder	
Single-phase/ 3-phase 200 V	*900 W	R88M-K90010H-□	R88M-K90010T-□	R88D-KN15H-ECT
3-phase 200 V	*2 kW	R88M-K2K010H-□	R88M-K2K010T-□	R88D-KN30H-ECT
	*3 kW	R88M-K3K010H-□	R88M-K3K010T-□	R88D-KN50H-ECT
	*4.5 kW	–	R88M-K4K510T-□	R88D-KN50H-ECT
	*6 kW	–	R88M-K6K010T-□	R88D-KN75H-ECT
3-phase 400 V	*900 W	R88M-K90010F-□	R88M-K90010C-□	R88D-KN15F-ECT
	*2 kW	R88M-K2K010F-□	R88M-K2K010C-□	R88D-KN30F-ECT
	*3 kW	R88M-K3K010F-□	R88M-K3K010C-□	R88D-KN50F-ECT
	*4.5 kW	–	R88M-K4K510C-□	R88D-KN50F-ECT
	*6 kW	–	R88M-K6K010C-□	R88D-KN75F-ECT

* Use these combination with caution because the Servo Drive and Servomotor have different capacities.

2-3-4 Reduction Gear Model Tables

The following tables list the Reduction Gear models for G5-series Servomotor. Select the model by the Servomotor capacity.

3 Arcminutes Max.

● For 3,000-r/min Servomotors

Specifications		Model
Servomotor capacity	Reduction Ratio	
50 W	1/5	R88G-HPG11B05100B□
	1/9	R88G-HPG11B09050B□
	1/21	R88G-HPG14A21100B□
	1/33	R88G-HPG14A33050B□
	1/45	R88G-HPG14A45050B□
100 W	1/5	R88G-HPG11B05100B□
	1/11	R88G-HPG14A11100B□
	1/21	R88G-HPG14A21100B□
	1/33	R88G-HPG20A33100B□
	1/45	R88G-HPG20A45100B□
200 W	1/5	R88G-HPG14A05200B□
	1/11	R88G-HPG14A11200B□
	1/21	R88G-HPG20A21200B□
	1/33	R88G-HPG20A33200B□
	1/45	R88G-HPG20A45200B□

Specifications		Model
Servomotor capacity	Reduction Ratio	
400 W	1/5	R88G-HPG14A05400B□
	1/11	R88G-HPG20A11400B□
	1/21	R88G-HPG20A21400B□
	1/33	R88G-HPG32A33400B□
	1/45	R88G-HPG32A45400B□
750 W (200 V)	1/5	R88G-HPG20A05750B□
	1/11	R88G-HPG20A11750B□
	1/21	R88G-HPG32A21750B□
	1/33	R88G-HPG32A33750B□
	1/45	R88G-HPG32A45750B□
750 W (400 V)	1/5	R88G-HPG32A052K0B□
	1/11	R88G-HPG32A112K0B□
	1/21	R88G-HPG32A211K5B□
	1/33	R88G-HPG32A33600SB□
	1/45	R88G-HPG50A451K5B□
1 kW	1/5	R88G-HPG32A052K0B□
	1/11	R88G-HPG32A112K0B□
	1/21	R88G-HPG32A211K5B□
	1/33	R88G-HPG50A332K0B□
	1/45	R88G-HPG50A451K5B□
1.5 kW	1/5	R88G-HPG32A052K0B□
	1/11	R88G-HPG32A112K0B□
	1/21	R88G-HPG32A211K5B□
	1/33	R88G-HPG50A332K0B□
	1/45	R88G-HPG50A451K5B□
2 kW	1/5	R88G-HPG32A052K0B□
	1/11	R88G-HPG32A112K0B□
	1/21	R88G-HPG50A212K0B□
	1/33	R88G-HPG50A332K0B□
3 kW	1/5	R88G-HPG32A053K0B□
	1/11	R88G-HPG50A113K0B□
	1/21	R88G-HPG50A213K0B□
4 kW	1/5	R88G-HPG32A054K0B□
	1/11	R88G-HPG50A115K0B□
5 kW	1/5	R88G-HPG50A055K0B□
	1/11	R88G-HPG50A115K0B□

Note 1 The standard shaft type is a straight shaft.

2 A model with a key and tap is indicated by adding "J" to the end of the model number (the suffix shown in the box).

(Example: R88G-HPG11B05100BJ)

● For 2,000-r/min Servomotors

Specifications		Model
Servomotor capacity	Reduction Ratio	
400 W	1/5	R88G-HPG32A052K0B□
	1/11	R88G-HPG32A112K0B□
	1/21	R88G-HPG32A211K5B□
	1/33	R88G-HPG32A33600SB□
	1/45	R88G-HPG32A45400SB□
600 W	1/5	R88G-HPG32A052K0B□
	1/11	R88G-HPG32A112K0B□
	1/21	R88G-HPG32A211K5B□
	1/33	R88G-HPG32A33600SB□
	1/45	R88G-HPG50A451K5B□
1 kW	1/5	R88G-HPG32A053K0B□
	1/11	R88G-HPG32A112K0SB□
	1/21	R88G-HPG32A211K0SB□
	1/33	R88G-HPG50A332K0SB□
	1/45	R88G-HPG50A451K0SB□
1.5 kW	1/5	R88G-HPG32A053K0B□
	1/11	R88G-HPG32A112K0SB□
	1/21	R88G-HPG50A213K0B□
	1/33	R88G-HPG50A332K0SB□
2 kW	1/5	R88G-HPG32A053K0B□
	1/11	R88G-HPG32A112K0SB□
	1/21	R88G-HPG50A213K0B□
	1/33	R88G-HPG50A332K0SB□
3 kW	1/5	R88G-HPG32A054K0B□
	1/11	R88G-HPG50A115K0B□
	1/21	R88G-HPG50A213K0SB□
	1/25	R88G-HPG65A253K0SB□
4 kW	1/5	R88G-HPG50A055K0SB□
	1/11	R88G-HPG50A115K0SB□
	1/20	R88G-HPG65A205K0SB□
	1/25	R88G-HPG65A255K0SB□
5 kW	1/5	R88G-HPG50A055K0SB□
	1/11	R88G-HPG50A115K0SB□
	1/20	R88G-HPG65A205K0SB□
	1/25	R88G-HPG65A255K0SB□

Note 1 The standard shaft type is a straight shaft.

2 A model with a key and tap is indicated by adding "J" to the end of the model number (the suffix shown in the box).

(Example: R88G-HPG32A053K0BJ)

● For 1,000-r/min Servomotors

Specifications		Model
Servomotor capacity	Reduction Ratio	
900 W	1/5	R88G-HPG32A05900TB□
	1/11	R88G-HPG32A11900TB□
	1/21	R88G-HPG50A21900TB□
	1/33	R88G-HPG50A33900TB□
2 kW	1/5	R88G-HPG32A052K0TB□
	1/11	R88G-HPG50A112K0TB□
	1/21	R88G-HPG50A212K0TB□
	1/25	R88G-HPG65A255K0SB□
3 kW	1/5	R88G-HPG50A055K0SB□
	1/11	R88G-HPG50A115K0SB□
	1/20	R88G-HPG65A205K0SB□
	1/25	R88G-HPG65A255K0SB□

Note 1 The standard shaft type is a straight shaft.

2 A model with a key and tap is indicated by adding “J” to the end of the model number (the suffix shown in the box).

(Example: R88G-HPG32A05900TBJ)

15 Arcminutes Max.

● For 3,000-r/min Servomotors (Straight Shaft with Key)

Specifications		Model
Servomotor capacity	Reduction Ratio	
50 W	1/5	R88G-VRSF05B100CJ
	1/9	R88G-VRSF09B100CJ
	1/15	R88G-VRSF15B100CJ
	1/25	R88G-VRSF25B100CJ
100 W	1/5	R88G-VRSF05B100CJ
	1/9	R88G-VRSF09B100CJ
	1/15	R88G-VRSF15B100CJ
	1/25	R88G-VRSF25B100CJ
200 W	1/5	R88G-VRSF05B200CJ
	1/9	R88G-VRSF09C200CJ
	1/15	R88G-VRSF15C200CJ
	1/25	R88G-VRSF25C200CJ
400 W	1/5	R88G-VRSF05C400CJ
	1/9	R88G-VRSF09C400CJ
	1/15	R88G-VRSF15C400CJ
	1/25	R88G-VRSF25C400CJ
750 W	1/5	R88G-VRSF05C750CJ
	1/9	R88G-VRSF09D750CJ
	1/15	R88G-VRSF15D750CJ
	1/25	R88G-VRSF25D750CJ

2-3-5 Cable and Peripheral Device Model Tables

The following tables list the models of cables and peripheral devices. The cables include motor power cables, brake cables, encoder cables, EtherCAT communications cables, and absolute encoder battery cables. The peripheral devices include Connectors, External Regeneration Resistors, and Mounting Brackets.

Encoder Cables (Standard Cable)

Specifications		Model
[100 V and 200 V] For 3,000-r/min Servomotors of 50 to 750 W (for both absolute encoders and incremental encoders)	3 m	R88A-CRKA003C
	5 m	R88A-CRKA005C
	10 m	R88A-CRKA010C
	15 m	R88A-CRKA015C
	20 m	R88A-CRKA020C
	30 m	R88A-CRKA030C
	40 m	R88A-CRKA040C
	50 m	R88A-CRKA050C
	[100 V and 200 V] 3,000-r/min Servomotors of 1.0 kW or more For 2,000-r/min Servomotors For 1,500-r/min Servomotors For 1,000-r/min Servomotors	3 m
5 m		R88A-CRKC005N
10 m		R88A-CRKC010N
15 m		R88A-CRKC015N
20 m		R88A-CRKC020N
30 m		R88A-CRKC030N
40 m		R88A-CRKC040N
[400 V] For 3,000-r/min Servomotors For 2,000-r/min Servomotors For 1,500-r/min Servomotors For 1,000-r/min Servomotors	50 m	R88A-CRKC050N

Motor Power Cables (Standard Cable)

Specifications	Model		
		For motor without brake	For motor with brake
[100 V and 200 V] For 3,000-r/min Servomotors of 50 to 750 W	3 m	R88A-CAKA003S	(See note 1.)
	5 m	R88A-CAKA005S	
	10 m	R88A-CAKA010S	
	15 m	R88A-CAKA015S	
	20 m	R88A-CAKA020S	
	30 m	R88A-CAKA030S	
	40 m	R88A-CAKA040S	
	50 m	R88A-CAKA050S	
[200 V] For 3,000-r/min Servomotors of 1 to 2 kW For 2,000-r/min Servomotors of 1 to 2 kW For 1,000-r/min Servomotors of 900 W	3 m	R88A-CAGB003S	R88A-CAGB003B
	5 m	R88A-CAGB005S	R88A-CAGB005B
	10 m	R88A-CAGB010S	R88A-CAGB010B
	15 m	R88A-CAGB015S	R88A-CAGB015B
	20 m	R88A-CAGB020S	R88A-CAGB020B
	30 m	R88A-CAGB030S	R88A-CAGB030B
	40 m	R88A-CAGB040S	R88A-CAGB040B
	50 m	R88A-CAGB050S	R88A-CAGB050B
[400 V] For 3,000-r/min Servomotors of 750 W to 2 kW For 2,000-r/min Servomotors of 400 W to 2 kW For 1,000-r/min Servomotors of 900 W	3 m	R88A-CAGB003S	R88A-CAKF003B
	5 m	R88A-CAGB005S	R88A-CAKF005B
	10 m	R88A-CAGB010S	R88A-CAKF010B
	15 m	R88A-CAGB015S	R88A-CAKF015B
	20 m	R88A-CAGB020S	R88A-CAKF020B
	30 m	R88A-CAGB030S	R88A-CAKF030B
	40 m	R88A-CAGB040S	R88A-CAKF040B
	50 m	R88A-CAGB050S	R88A-CAKF050B
For 3,000-r/min Servomotors of 3 to 5 kW For 2,000-r/min Servomotors of 3 to 5 kW For 1,000-r/min Servomotors of 2 to 4.5 kW	3 m	R88A-CAGD003S	R88A-CAGD003B
	5 m	R88A-CAGD005S	R88A-CAGD005B
	10 m	R88A-CAGD010S	R88A-CAGD010B
	15 m	R88A-CAGD015S	R88A-CAGD015B
	20 m	R88A-CAGD020S	R88A-CAGD020B
	30 m	R88A-CAGD030S	R88A-CAGD030B
	40 m	R88A-CAGD040S	R88A-CAGD040B
	50 m	R88A-CAGD050S	R88A-CAGD050B
For 2,000-r/min Servomotors of 7.5 kW For 1,000-r/min Servomotors of 6 kW	3 m	R88A-CAGE003S	–
	5 m	R88A-CAGE005S	–
	10 m	R88A-CAGE010S	–
	15 m	R88A-CAGE015S	–
	20 m	R88A-CAGE020S	–
	30 m	R88A-CAGE030S	–
	40 m	R88A-CAGE040S	–
	50 m	R88A-CAGE050S	–

- Note 1** Different connectors are used for the motor power and the brake on 100-V and 200-V, 3,000-r/min Servomotors of 50 to 750 W and Servomotors of 6 to 15 kW. When using a Servomotor with a brake, two cables are required: a Power Cable without Brake and a Brake Cable.
- 2** For flexible power cables for Servomotors of 11 to 15 kW, refer to 4-2 Wiring (page 4-10) and make your own cable.

Brake Cables (Standard Cable)

Specifications	Model	
[100 V and 200 V] For 3,000-r/min Servomotors of 50 to 750 W	3 m	R88A-CAKA003B
	5 m	R88A-CAKA005B
	10 m	R88A-CAKA010B
	15 m	R88A-CAKA015B
	20 m	R88A-CAKA020B
	30 m	R88A-CAKA030B
	40 m	R88A-CAKA040B
	50 m	R88A-CAKA050B
For 1,500-r/min Servomotors of 7.5 to 15 kW For 1,000-r/min Servomotors of 6 kW	3 m	R88A-CAGE003B
	5 m	R88A-CAGE005B
	10 m	R88A-CAGE010B
	15 m	R88A-CAGE015B
	20 m	R88A-CAGE020B
	30 m	R88A-CAGE030B
	40 m	R88A-CAGE040B
	50 m	R88A-CAGE050B

Encoder Cables (Robot Cable)

Specifications		Model
[100 V and 200 V] For 3,000-r/min Servomotors of 50 to 750 W (for both absolute encoders and incremental encoders)	3 m	R88A-CRKA003CR
	5 m	R88A-CRKA005CR
	10 m	R88A-CRKA010CR
	15 m	R88A-CRKA015CR
	20 m	R88A-CRKA020CR
	30 m	R88A-CRKA030CR
	40 m	R88A-CRKA040CR
	50 m	R88A-CRKA050CR
[100 V and 200 V] 3,000-r/min Servomotors of 1.0 kW or more For 2,000-r/min Servomotors For 1,000-r/min Servomotors	3 m	R88A-CRKC003NR
	5 m	R88A-CRKC005NR
	10 m	R88A-CRKC010NR
	15 m	R88A-CRKC015NR
	20 m	R88A-CRKC020NR
[400 V] For 3,000-r/min Servomotors For 2,000-r/min Servomotors For 1,500-r/min Servomotors For 1,000-r/min Servomotors	30 m	R88A-CRKC030NR
	40 m	R88A-CRKC040NR
	50 m	R88A-CRKC050NR

Motor Power Cables (Robot Cable)

Specifications		Model	
		For motor without brake	For motor with brake
[100 V and 200 V] For 3,000-r/min Servomotors of 50 to 750 W	3 m	R88A-CAKA003SR	–
	5 m	R88A-CAKA005SR	–
	10 m	R88A-CAKA010SR	–
	15 m	R88A-CAKA015SR	–
	20 m	R88A-CAKA020SR	–
	30 m	R88A-CAKA030SR	–
	40 m	R88A-CAKA040SR	–
	50 m	R88A-CAKA050SR	–
[200 V] For 3,000-r/min Servomotors of 1 to 2 kW For 2,000-r/min Servomotors of 1 to 2 kW For 1,000-r/min Servomotors of 900 W	3 m	R88A-CAGB003SR	R88A-CAGB003BR
	5 m	R88A-CAGB005SR	R88A-CAGB005BR
	10 m	R88A-CAGB010SR	R88A-CAGB010BR
	15 m	R88A-CAGB015SR	R88A-CAGB015BR
	20 m	R88A-CAGB020SR	R88A-CAGB020BR
	30 m	R88A-CAGB030SR	R88A-CAGB030BR
	40 m	R88A-CAGB040SR	R88A-CAGB040BR
	50 m	R88A-CAGB050SR	R88A-CAGB050BR
[400 V] For 3,000-r/min Servomotors of 750 W to 2 kW For 2,000-r/min Servomotors of 400 W to 2 kW For 1,000-r/min Servomotors of 900 W	3 m	R88A-CAGB003SR	R88A-CAKF003BR
	5 m	R88A-CAGB005SR	R88A-CAKF005BR
	10 m	R88A-CAGB010SR	R88A-CAKF010BR
	15 m	R88A-CAGB015SR	R88A-CAKF015BR
	20 m	R88A-CAGB020SR	R88A-CAKF020BR
	30 m	R88A-CAGB030SR	R88A-CAKF030BR
	40 m	R88A-CAGB040SR	R88A-CAKF040BR
	50 m	R88A-CAGB050SR	R88A-CAKF050BR
For 3,000-r/min Servomotors of 3 to 5 kW For 2,000-r/min Servomotors of 3 to 5 kW For 1,000-r/min Servomotors of 2 to 4.5 kW	3 m	R88A-CAGD003SR	R88A-CAGD003BR
	5 m	R88A-CAGD005SR	R88A-CAGD005BR
	10 m	R88A-CAGD010SR	R88A-CAGD010BR
	15 m	R88A-CAGD015SR	R88A-CAGD015BR
	20 m	R88A-CAGD020SR	R88A-CAGD020BR
	30 m	R88A-CAGD030SR	R88A-CAGD030BR
	40 m	R88A-CAGD040SR	R88A-CAGD040BR
	50 m	R88A-CAGD050SR	R88A-CAGD050BR

- Note 1** Different connectors are used for the motor power and the brake on 100-V and 200-V, 3,000-r/min Servomotors of 50 to 750 W and Servomotors of 6 to 15 kW. When using a Servomotor with a brake, two cables are required: a Power Cable without Brake and a Brake Cable.
- 2** For flexible power cables for Servomotors of 11 to 15 kW, refer to *4-2 Wiring* on page 4-10 and make your own cable.
For flexible power cables for Servomotors of 6 to 7.5 kW, refer to *3-5-1 Bend Radius of Robot Cable* on page 3-67 and *3-5-4 Motor Power Cable Specifications* on page 3-75 and make your own power cable.

Brake Cables (Robot Cable)

Specifications		Model
[100 V and 200 V] For 3,000-r/min Servomotors of 50 to 750 W	3 m	R88A-CAKA003BR
	5 m	R88A-CAKA005BR
	10 m	R88A-CAKA010BR
	15 m	R88A-CAKA015BR
	20 m	R88A-CAKA020BR
	30 m	R88A-CAKA030BR
	40 m	R88A-CAKA040BR
	50 m	R88A-CAKA050BR

Note For flexible brake cables for Servomotors of 6 to 15 kW, refer to *3-5 Cable and Connector Specifications* and make your own brake cable.

EtherCAT Communications Cable (Recommended)

Size x Number of cable cores (pairs)	Recommended manufacturer	Model
AWG24 x 4P	Tonichi kyosan Cable, Ltd.	NETSTAR-C5E SAB 0.5 × 4P
	Kuramo Electric Co.	KETH-SB
	SWCC Showa Cable Systems Co.	FAE-5004
AWG22 x 2P	Kuramo Electric Co.	KETH-PSB-OMR

Ethernet Category 5 (100BASE-TX) or higher (twisted-pair cable with double, aluminum tape and braided shielding) is recommended.

Absolute Encoder Battery Cables

Name		Model
Absolute Encoder Battery Cable (battery not supplied)	0.3 m	R88A-CRGD0R3C
Absolute Encoder Battery Cable (R88A-BAT01G battery × 1 supplied)	0.3 m	R88A-CRGD0R3C-BS

Absolute Encoder Backup Battery

Name	Model
Absolute Encoder Backup Battery	R88A-BAT01G

Analog Monitor Cable

Name		Model
Analog Monitor Cable	1 m	R88A-CMK001S

Connectors

Name and applications		Model
Motor Connector for Encoder Cable	[100 V and 200 V] For 3,000-r/min of 50 to 750 W	R88A-CNK02R
	[100 V and 200 V] For 3,000-r/min of 1 to 5 kW For 2,000 r/min, 1,000 r/min [400 V] For 3,000 r/min, 2,000 r/min and 1,000 r/min	R88A-CNK04R
Control I/O Connector (CN1)		R88A-CNW01C
Encoder Connector (CN2)		R88A-CNW01R
External Encoder Connector (CN4)		R88A-CNK41L
Safety Connector (CN8)		R88A-CNK81S
Power Cable Connector (for 750 W max.)		R88A-CNK11A
Brake Cable Connector (for 750 W max.)		R88A-CNK11B

Control Cables

Name		Model
Connector-terminal Block Cables	1 m	XW2Z-100J-B34
	2 m	XW2Z-200J-B34
Connector-terminal Block	M3 screws	XW2B-20G4
	M3.5 screws	XW2B-20G5
	M3 screws	XW2D-20G6

External Regeneration Resistors

Specifications	Model
Regeneration process capacity: 20 W, 50 Ω (with 150°C thermal sensor)	R88A-RR08050S
Regeneration process capacity: 20 W, 100 Ω (with 150°C thermal sensor)	R88A-RR080100S
Regeneration process capacity: 70 W, 47 Ω (with 150°C thermal sensor)	R88A-RR22047S1
Regeneration process capacity: 180 W, 20 Ω (with 200°C thermal sensor)	R88A-RR50020S

Reactor

Servo Drive		Reactor
Model	Number of power phases	Model
R88D-KNA5L-ECT	Single-phase	3G3AX-DL2002
R88D-KN01L-ECT		3G3AX-DL2004
R88D-KN02L-ECT		3G3AX-DL2007
R88D-KN04L-ECT		3G3AX-DL2015
R88D-KN01H-ECT	Single-phase	3G3AX-DL2002
	Three-phase	3G3AX-AL2025
R88D-KN02H-ECT	Single-phase	3G3AX-DL2004
	Three-phase	3G3AX-AL2025
R88D-KN04H-ECT	Single-phase	3G3AX-DL2007
	Three-phase	3G3AX-AL2025
R88D-KN08H-ECT	Single-phase	3G3AX-DL2015
	Three-phase	3G3AX-AL2025
R88D-KN10H-ECT	Single-phase	3G3AX-DL2015
	Three-phase	3G3AX-AL2025
R88D-KN15H-ECT	Single-phase	3G3AX-DL2022
	Three-phase	3G3AX-AL2025
R88D-KN20H-ECT	Three-phase	3G3AX-AL2055
R88D-KN30H-ECT		
R88D-KN50H-ECT		3G3AX-AL2110
R88D-KN75H-ECT		3G3AX-AL2220
R88D-KN150H-ECT		
R88D-KN06F-ECT		3G3AX-AL4025
R88D-KN10F-ECT		
R88D-KN15F-ECT		
R88D-KN20F-ECT		3G3AX-AL4055
R88D-KN30F-ECT		
R88D-KN50F-ECT		3G3AX-AL4110
R88D-KN75F-ECT		3G3AX-AL4220
R88D-KN150F-ECT		

Mounting Brackets (L-brackets for Rack Mounting)

Applicable Servo Drives	Model
R88D-KNA5L-ECT/-KN01L-ECT/-KN01H-ECT/-KN02H-ECT	R88A-TK01K
R88D-KN02L-ECT/-KN04H-ECT	R88A-TK02K
R88D-KN04L-ECT/-KN08H-ECT	R88A-TK03K
R88D-KN10H-ECT/-KN15H-ECT/-KN06F-ECT/-KN10F-ECT/-KN15F-ECT	R88A-TK04K

2-4 External and Mounting Dimensions

This section describes the external dimensions and the mounting dimensions of Servo Drives, Servomotors, and peripheral devices.

2-4-1 Servo Drive Dimensions

The dimensional description starts with a Servo Drive of the smallest motor capacity, which is followed by the next smallest, and so on.

Single-phase 100 VAC: R88D-KNA5L-ECT/-KN01L-ECT (50 to 100 W)
Single-phase/3-phase 200 VAC: R88D-KN01H-ECT/-KN02H-ECT
(100 to 200 W)

- Wall Mounting

External dimensions

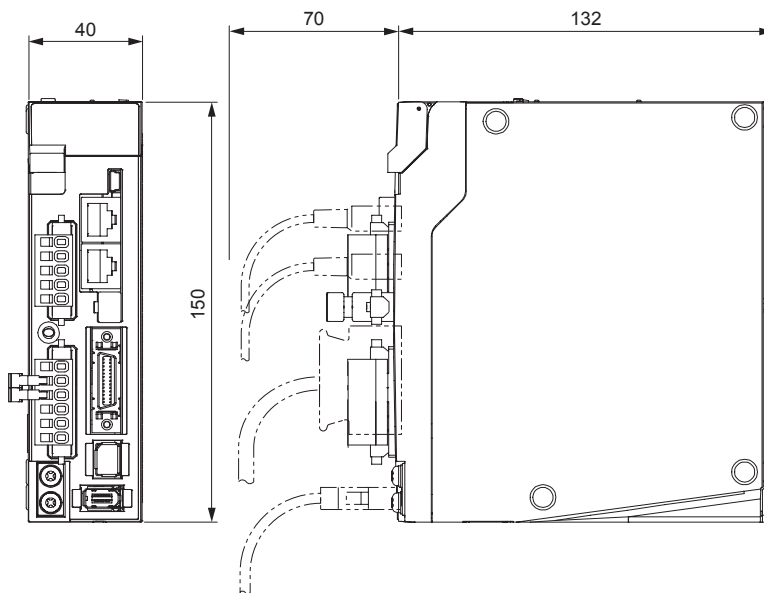

Mounting dimensions

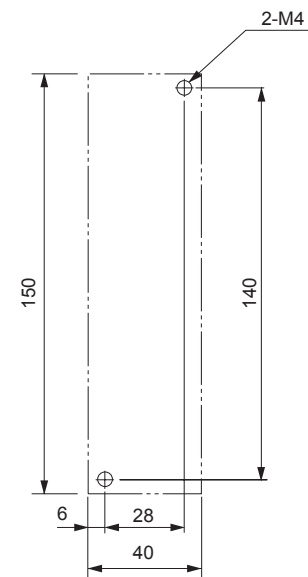

● Front Mounting (Using Front Mounting Brackets)

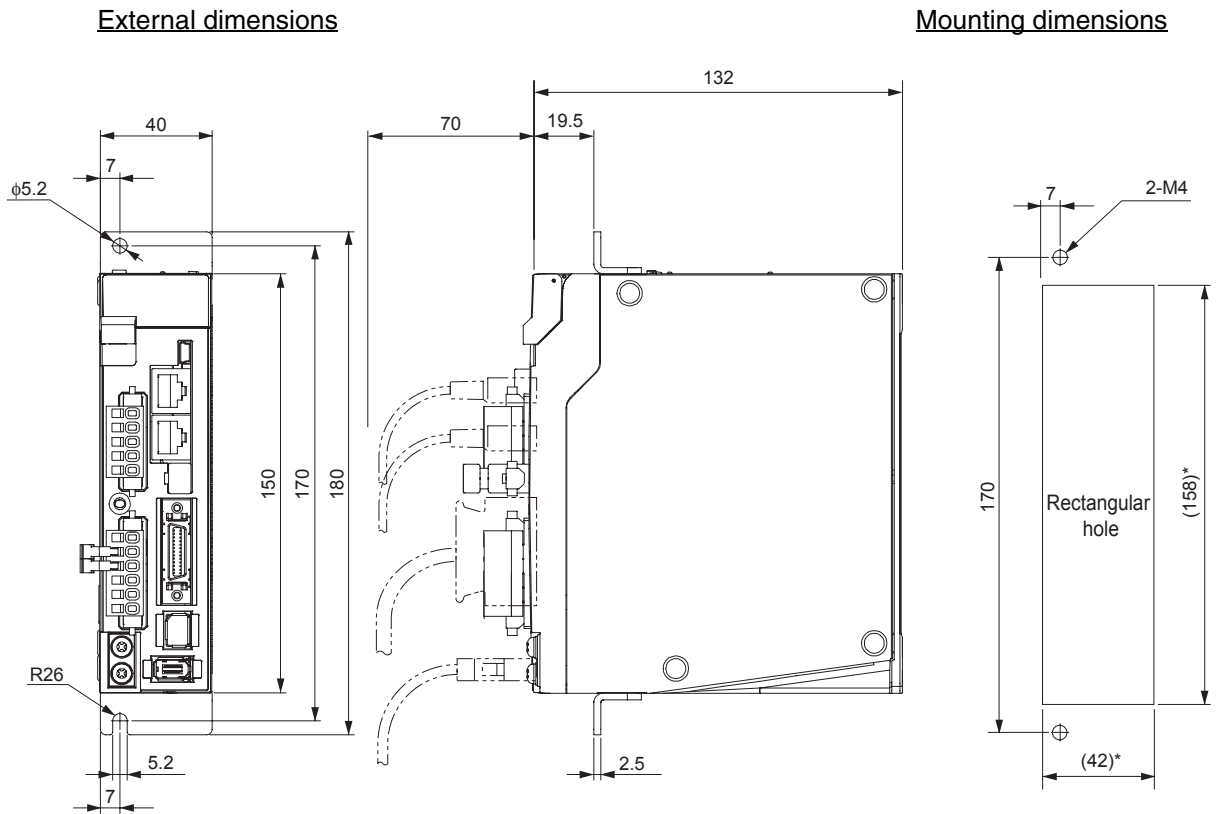

* Rectangular hole dimensions are reference values.

Single-phase/3-phase 100 VAC: R88D-KN02L-ECT (200 W)
Single-phase/3-phase 200 VAC: R88D-KN04H-ECT (400 W)

● **Wall Mounting**

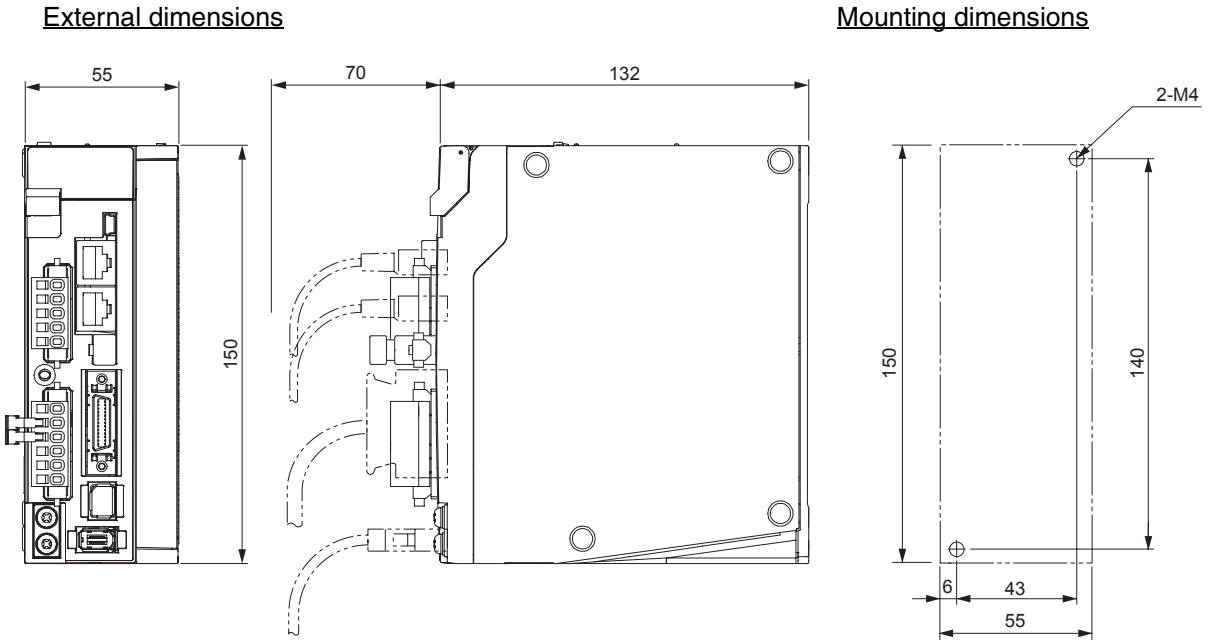

● **Front Mounting (Using Front Mounting Brackets)**

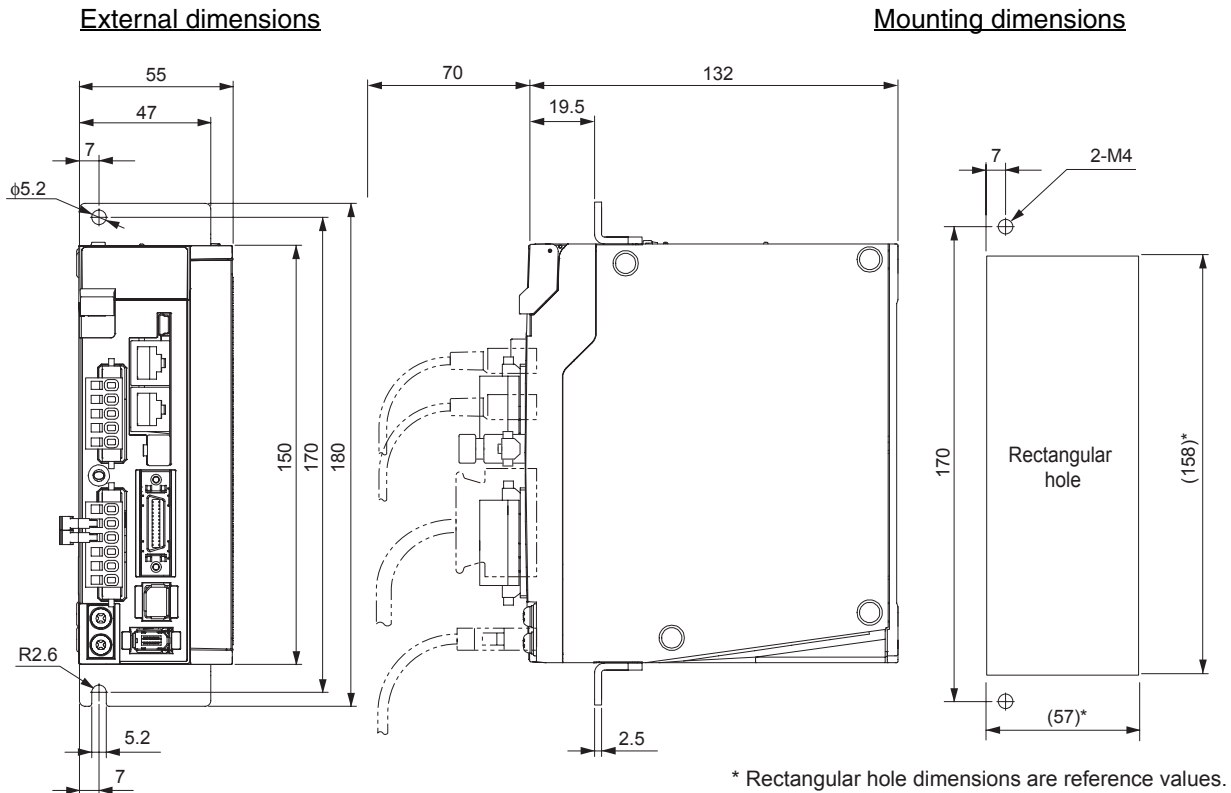

Single-phase/3-phase 100 VAC: R88D-KN04L-ECT (400 W)
Single-phase/3-phase 200 VAC: R88D-KN08H-ECT (750 W)

● **Wall Mounting**

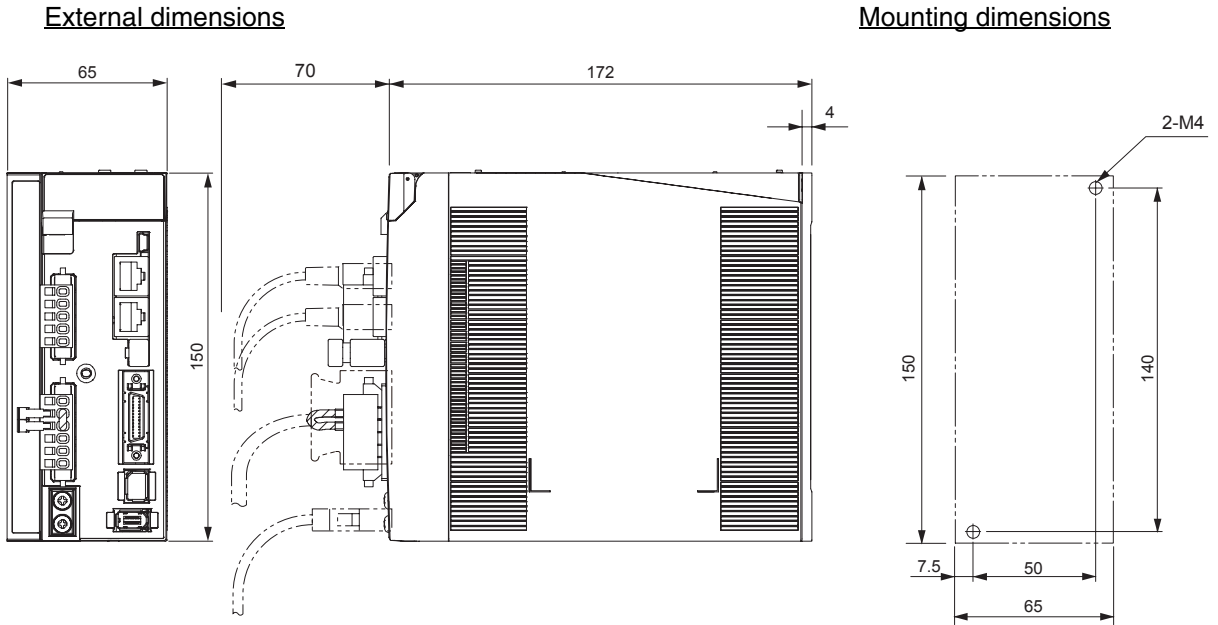

● **Front Mounting (Using Front Mounting Brackets)**

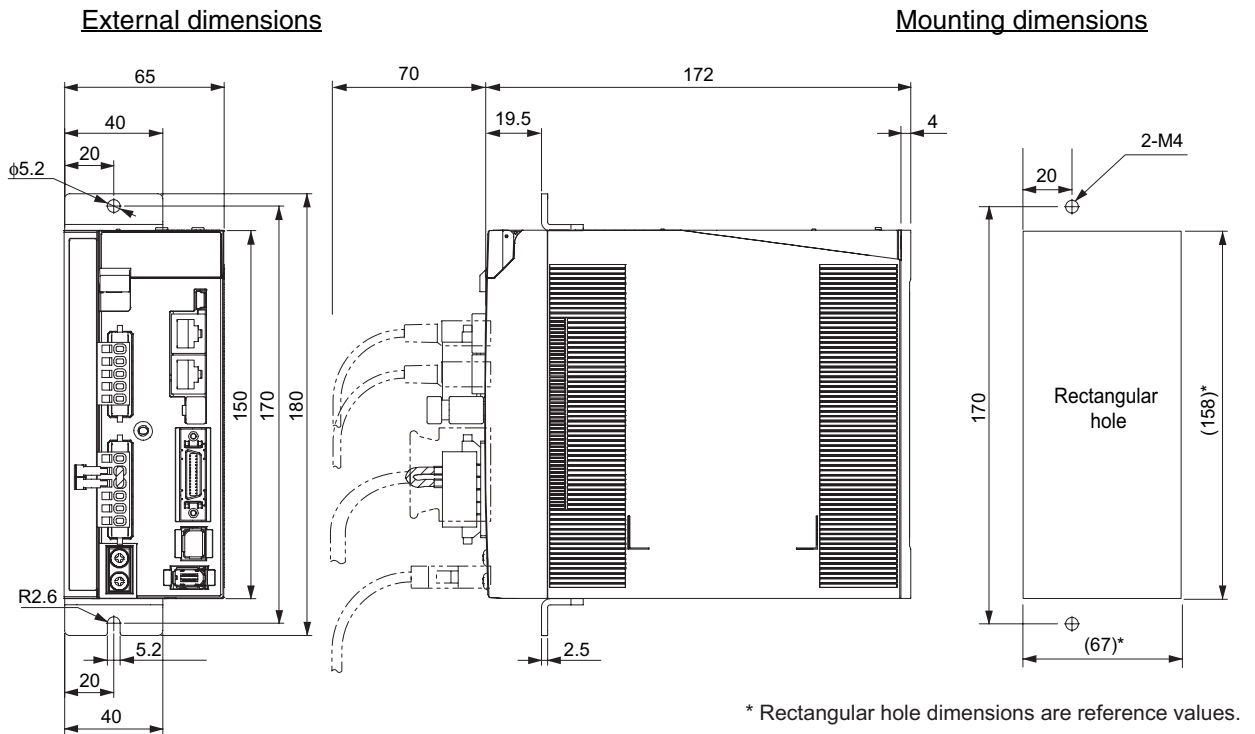

**Single-phase/3-phase 200 VAC: R88D-KN10H-ECT/-KN15H-ECT
(900 W to 1.5 kW)**

● **Wall Mounting**

External dimensions

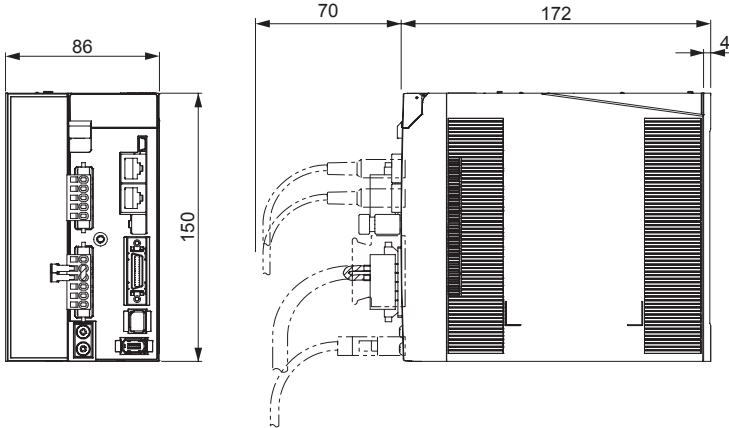

Mounting dimensions

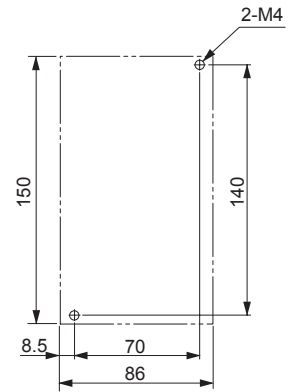

● **Front Mounting (Using Front Mounting Brackets)**

External dimensions

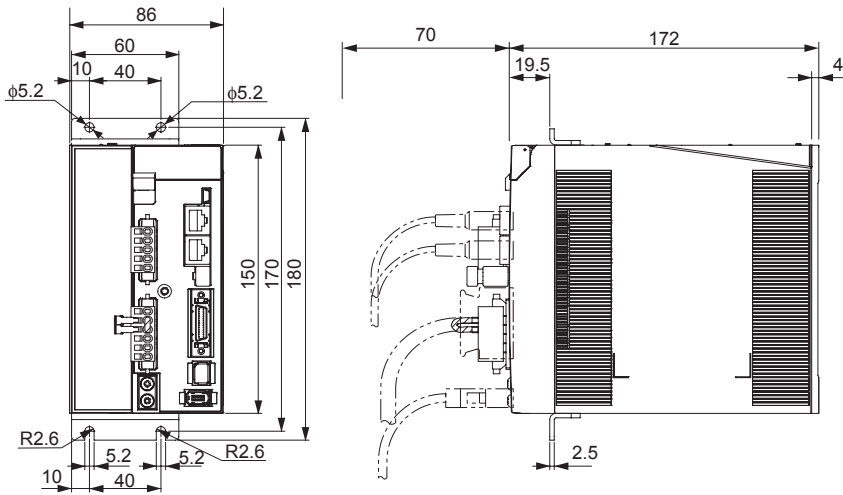

Mounting dimensions

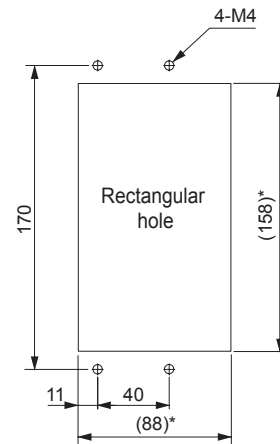

* Rectangular hole dimensions are reference values.

3-phase 200 VAC: R88D-KN20H-ECT (2 kW)

● Wall Mounting

External dimensions

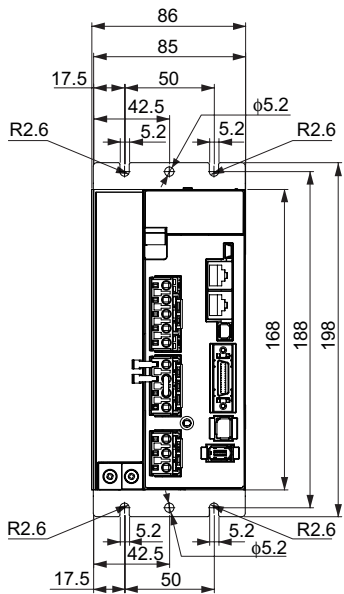

Mounting dimensions

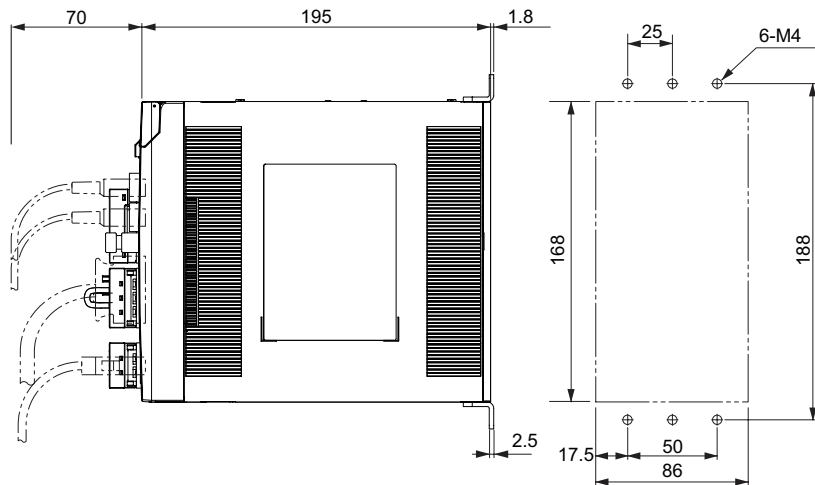

● Front Mounting (Using Front Mounting Brackets)

External dimensions

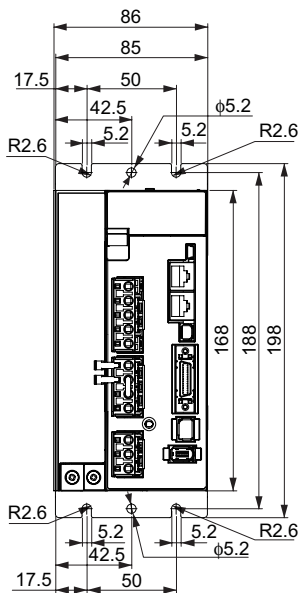

Mounting dimensions

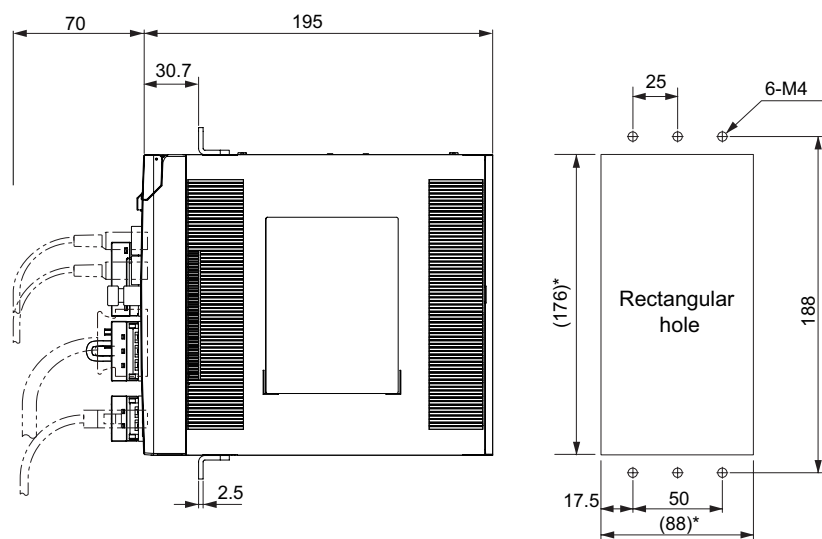

* Rectangular hole dimensions are reference values.

3-phase 200 VAC: R88D-KN30H-ECT/-KN50H-ECT (3 to 5 kW)

● **Wall Mounting**

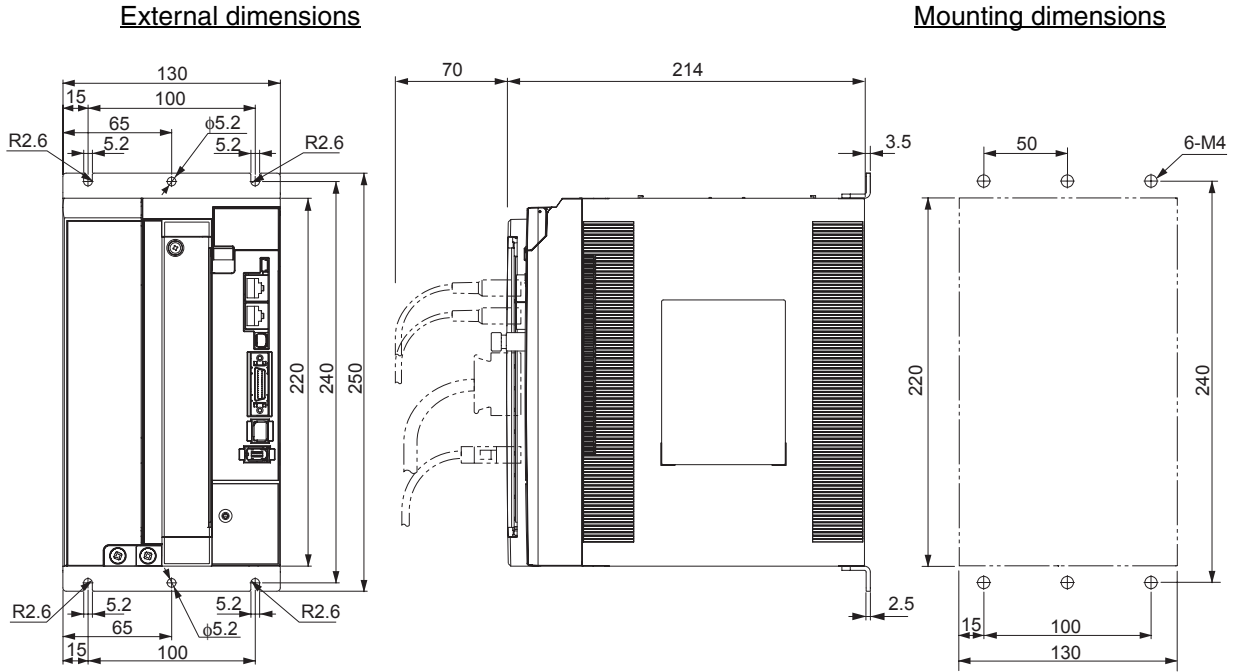

● **Front Mounting (Using Front Mounting Brackets)**

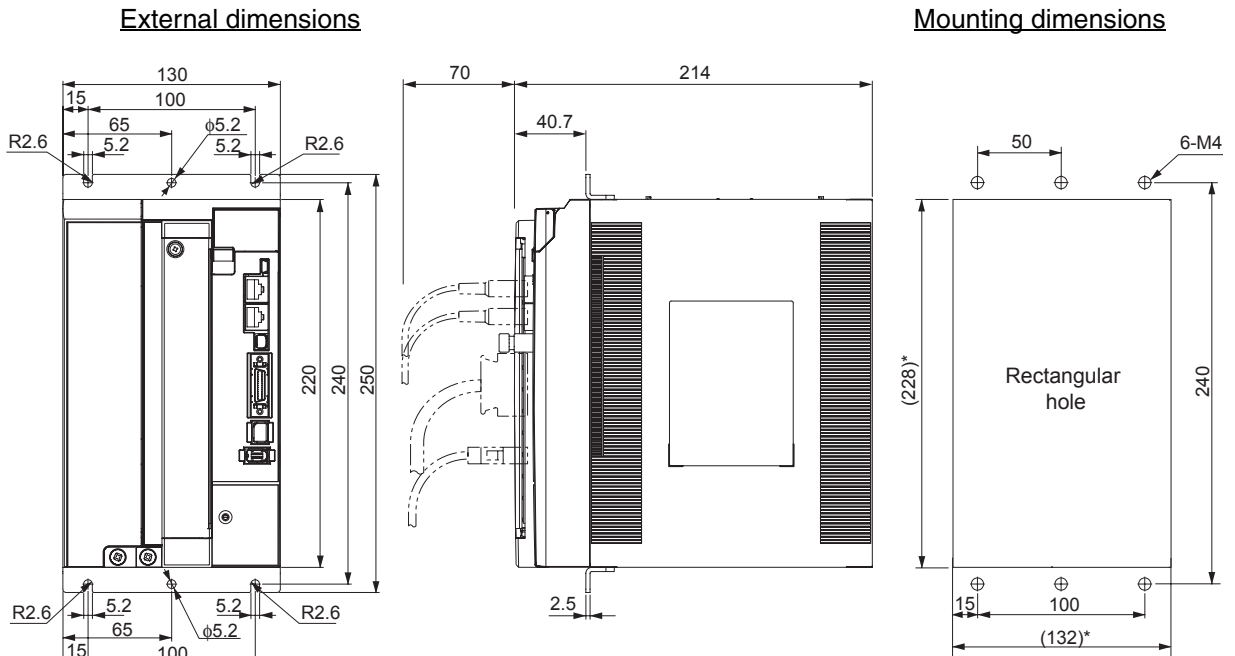

* Rectangular hole dimensions are reference values.

3-phase 200 VAC: R88D-KN75H-ECT (7.5 kW)

● Wall Mounting

External dimensions

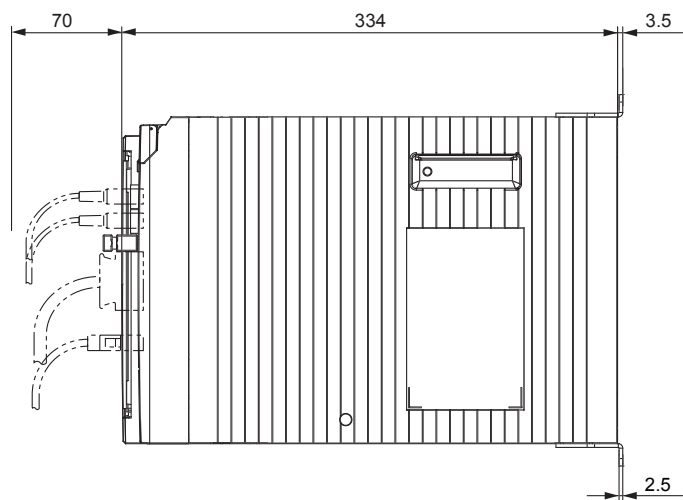
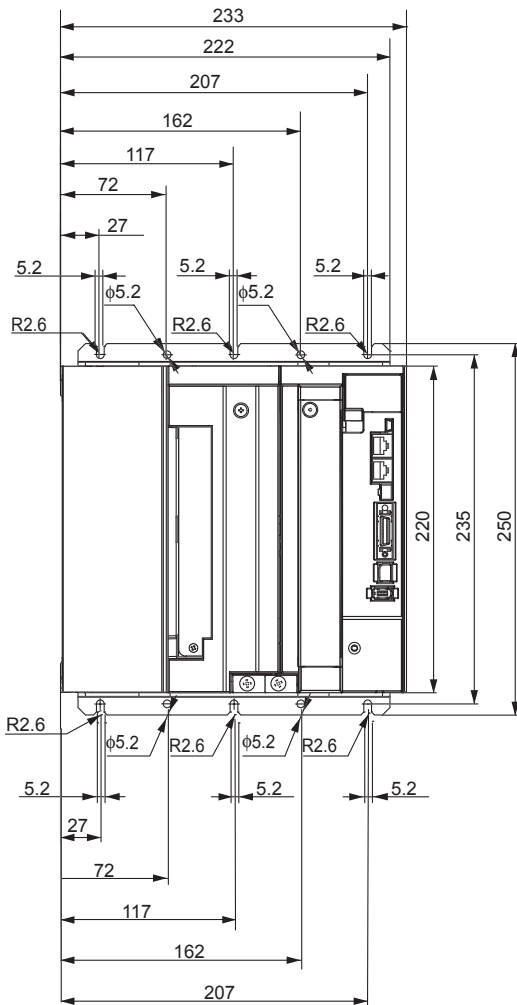

Mounting dimensions

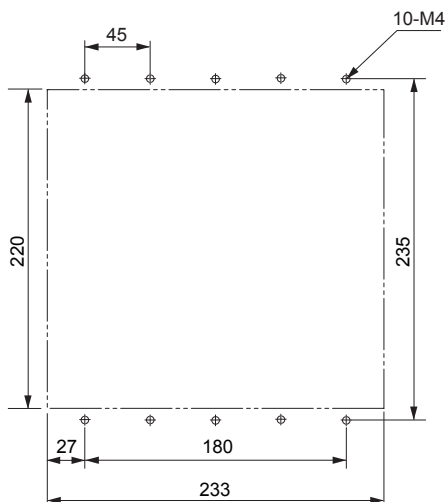

● **Front Mounting (Using Front Mounting Brackets)**

External dimensions

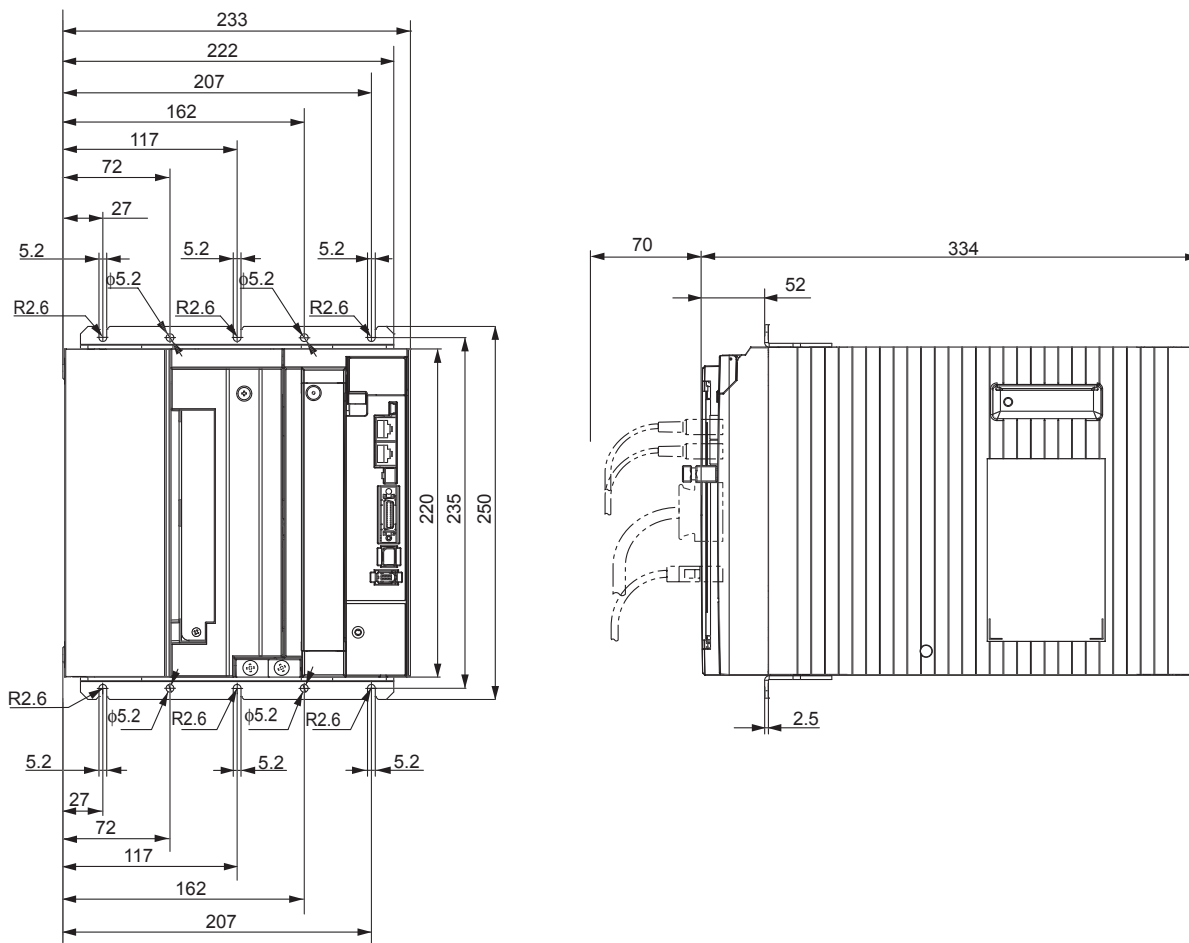

Mounting dimensions

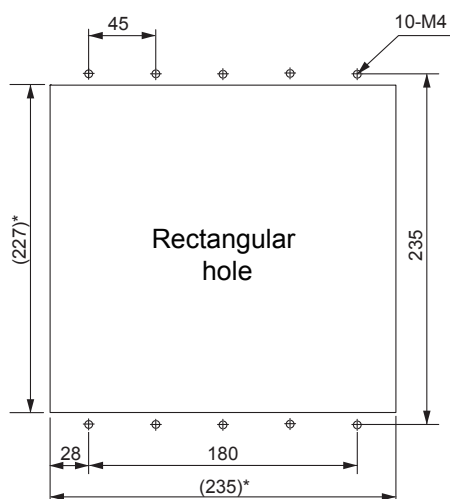

* Rectangular hole dimensions are reference values.

3-phase 200 VAC: R88D-KN150H-ECT (15 kW)

● Wall Mounting

External dimensions

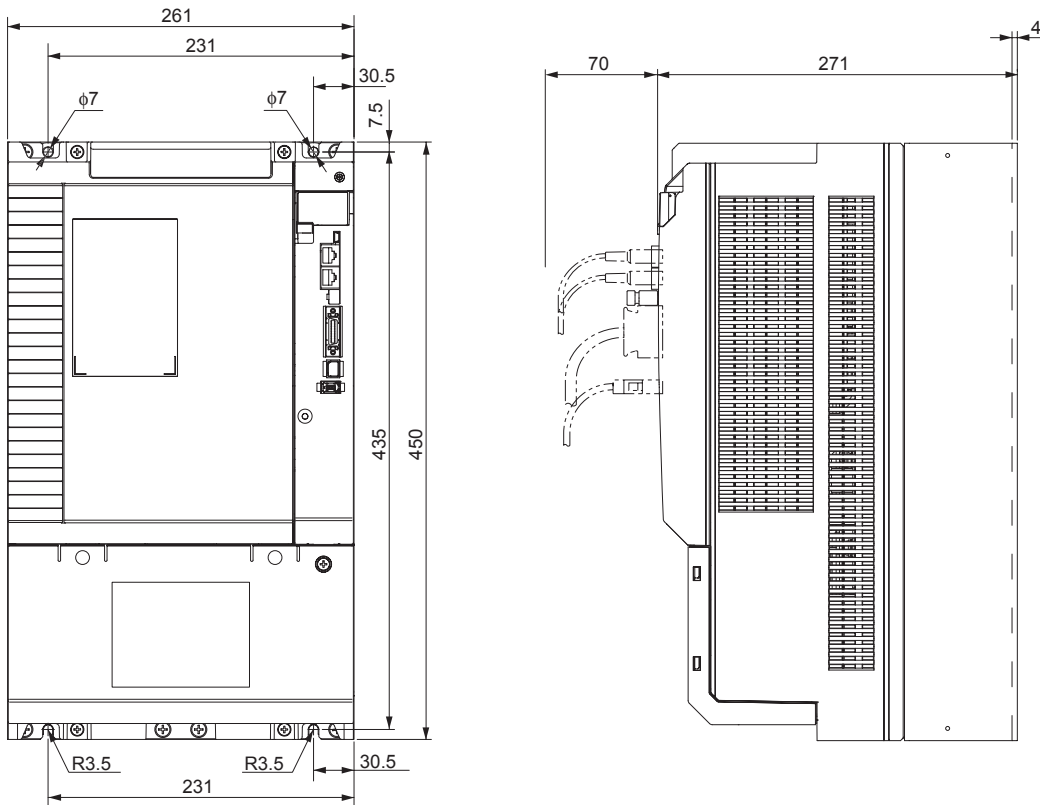

Mounting dimensions

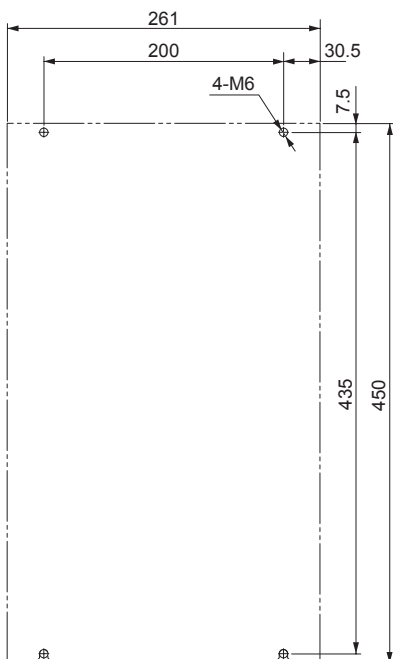

3-phase 400 VAC: R88D-KN06F-ECT/-KN10F-ECT (600 W to 1.0 kW)
3-phase 400 VAC: R88D-KN15F-ECT (1.5 kW)

● **Wall Mounting**

External dimensions

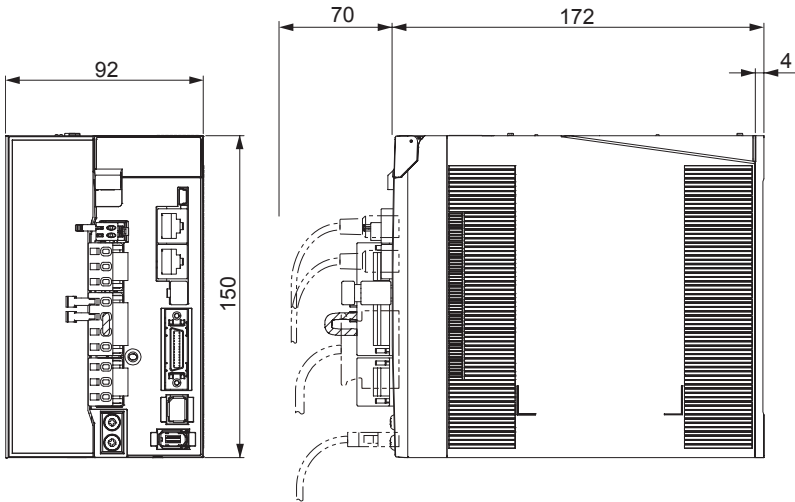

Mounting dimensions

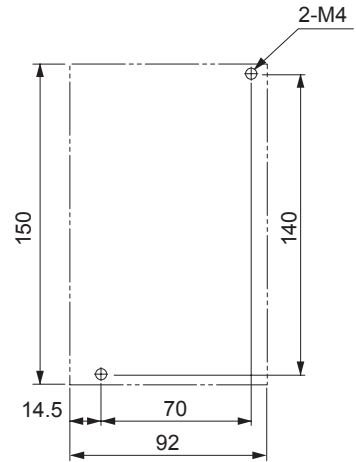

● **Front Mounting (Using Front Mounting Brackets)**

External dimensions

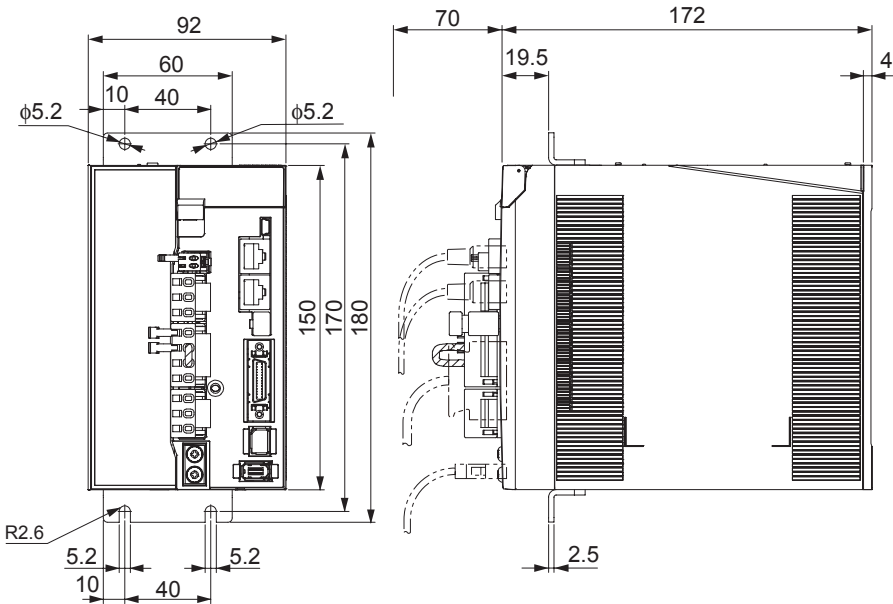

Mounting dimensions

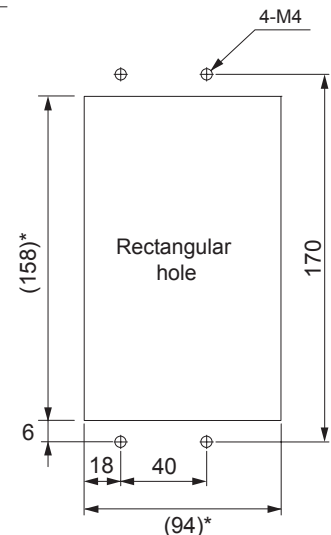

* Rectangular hole dimensions are reference values.

3-phase 400 VAC: R88D-KN20F-ECT (2 kW)

● Wall Mounting

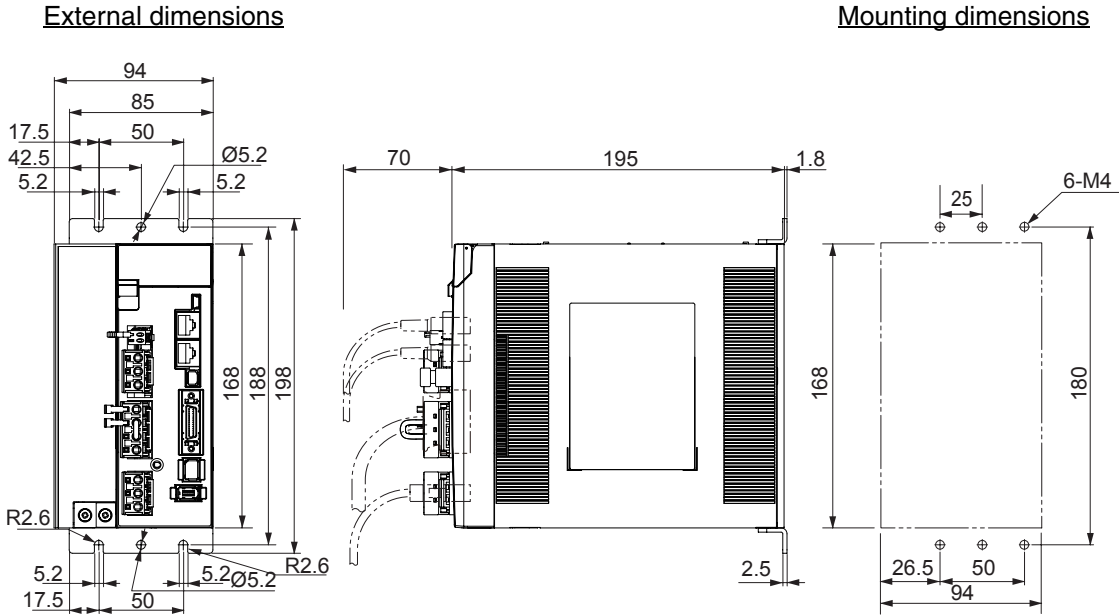

● Front Mounting (Using Front Mounting Brackets)

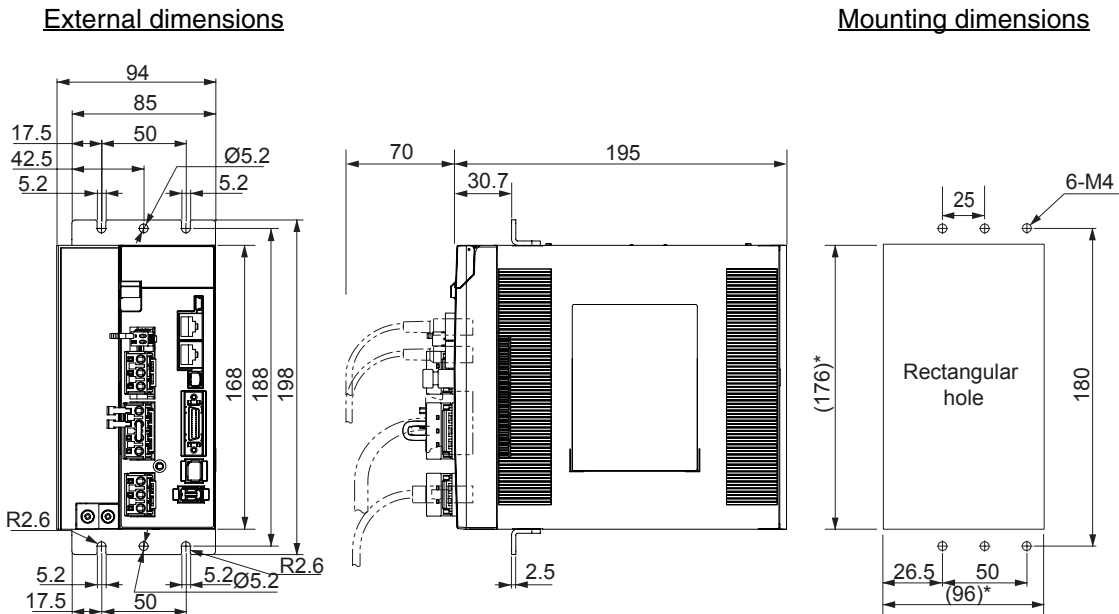

* Rectangular hole dimensions are reference values.

3-phase 400 VAC: R88D-KN30F-ECT/-KN50F-ECT (3 to 5 kW)

● Wall Mounting

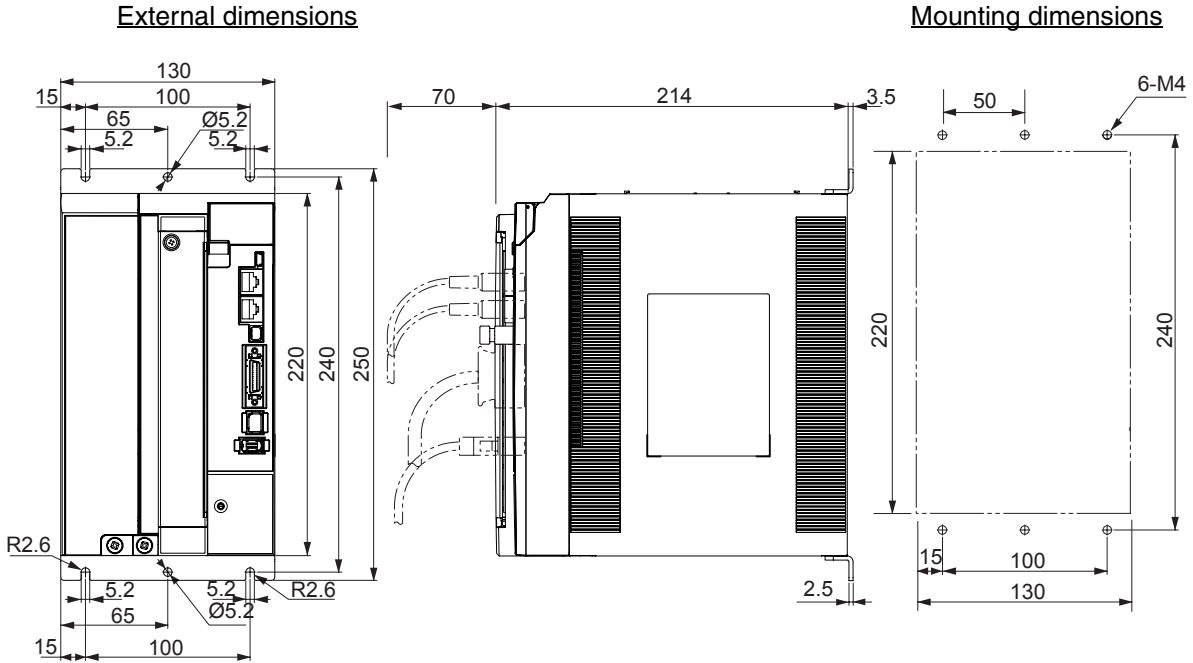

● Front Mounting (Using Front Mounting Brackets)

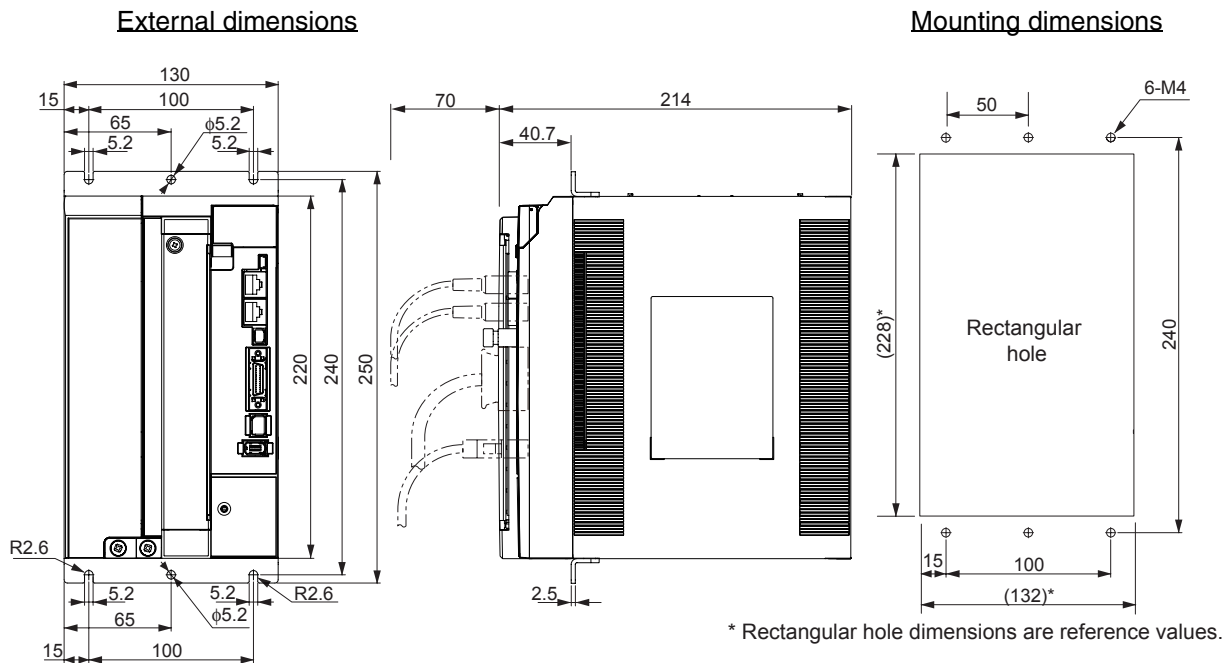

3-phase 400 VAC: R88D-KN75F-ECT (7.5 kW)

● Wall Mounting

External dimensions

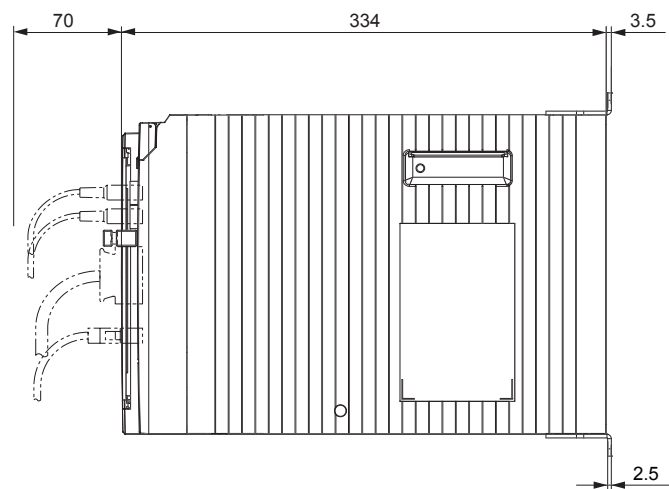
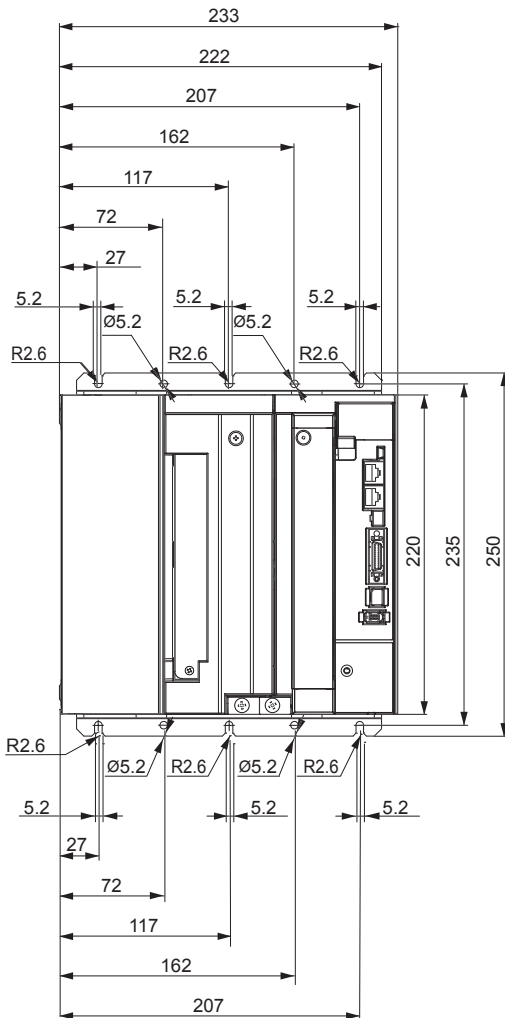

Mounting dimensions

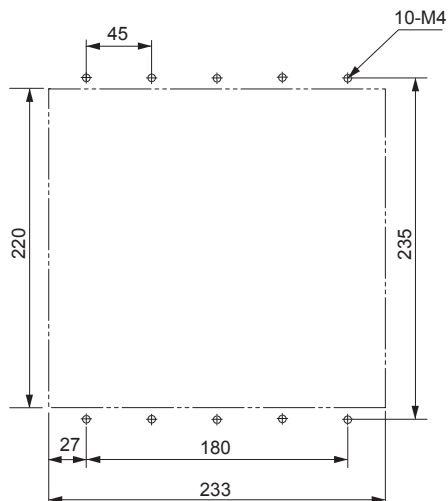

● Front Mounting (Using Front Mounting Brackets)

External dimensions

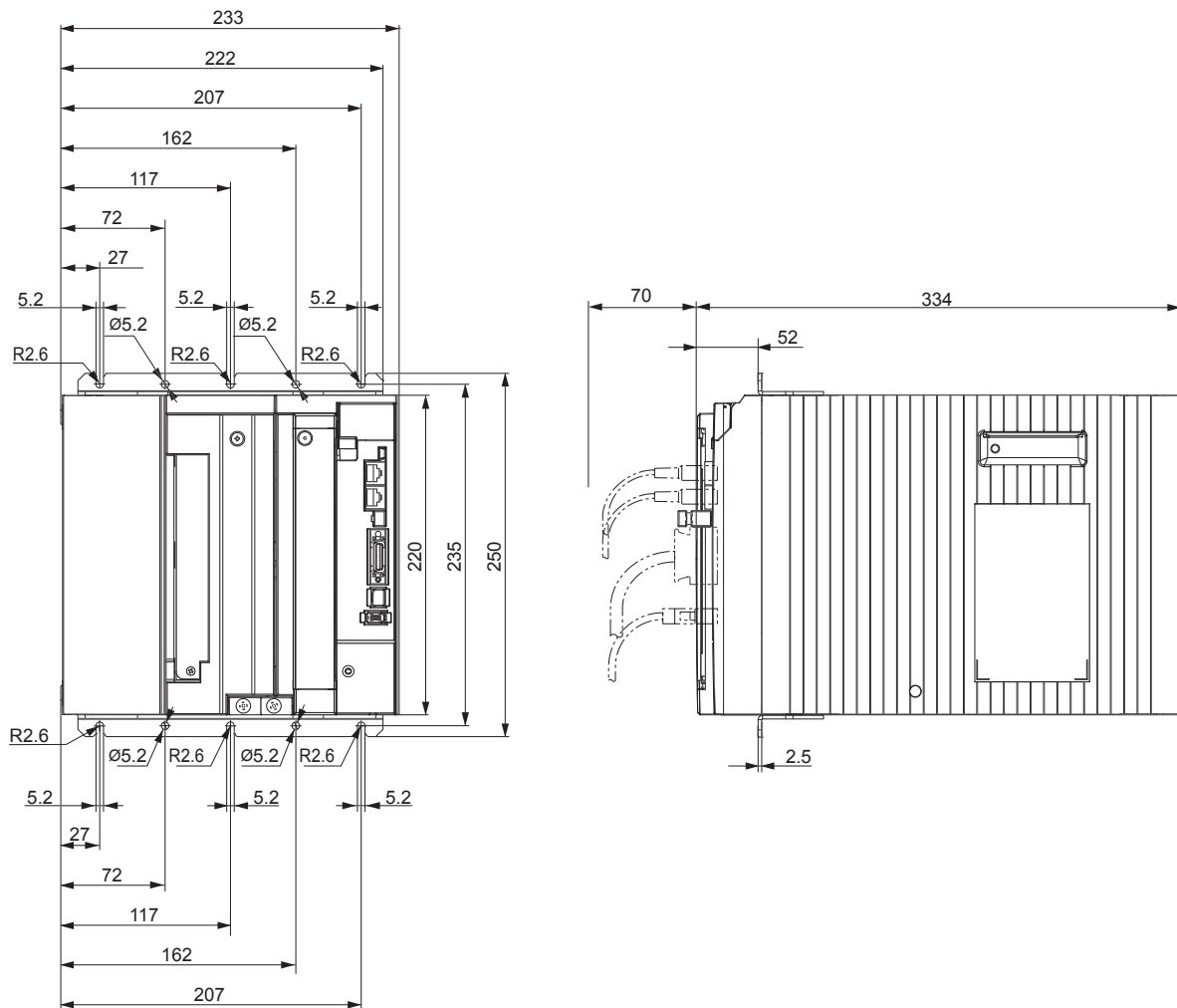

Mounting dimensions

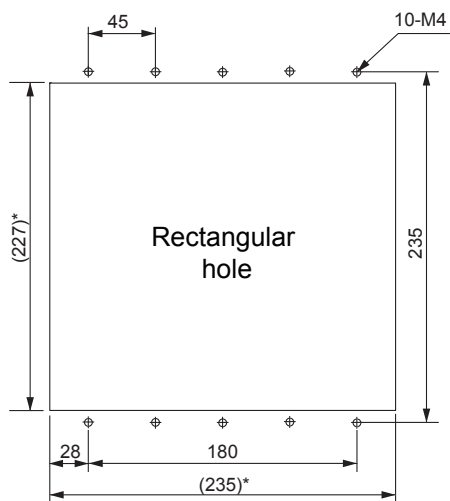

* Rectangular hole dimensions are reference values.

3-phase 400 VAC: R88D-KN150F-ECT (15 kW)

● Wall Mounting

External dimensions

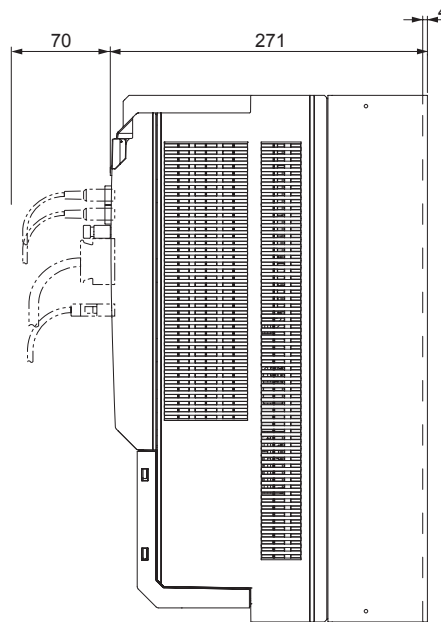
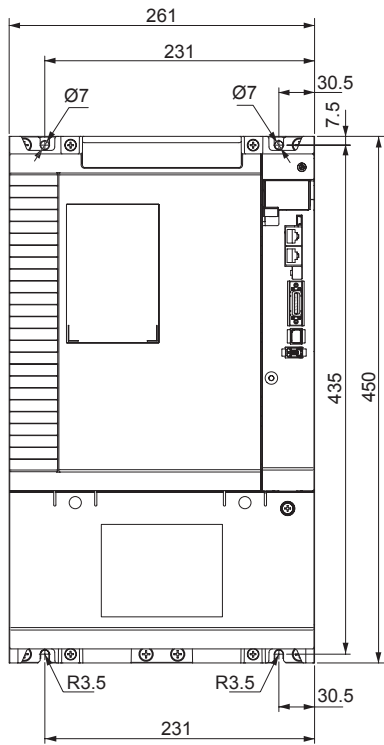

Mounting dimensions

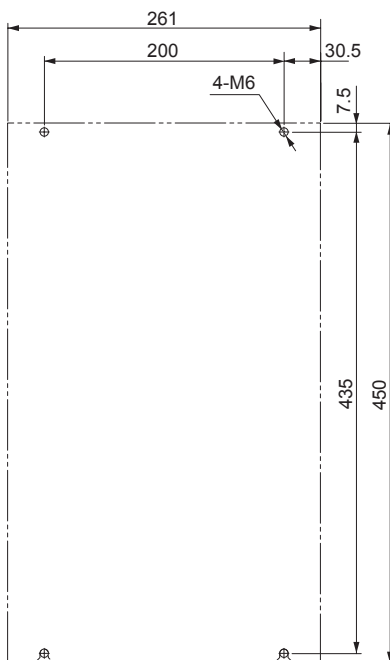

2-4-2 Servomotor Dimensions

In this description, the Servomotors are grouped by rated rotation speed. The description starts with a Servomotor of the smallest capacity, which is followed by the next smallest, and so on.

3,000-r/min Servomotors (100 V and 200 V)

● 50 W/100 W (without Brake)

R88M-K05030H (-S2)/-K10030□ (-S2) **INC**

R88M-K05030T (-S2)/-K10030□ (-S2) **ABS**

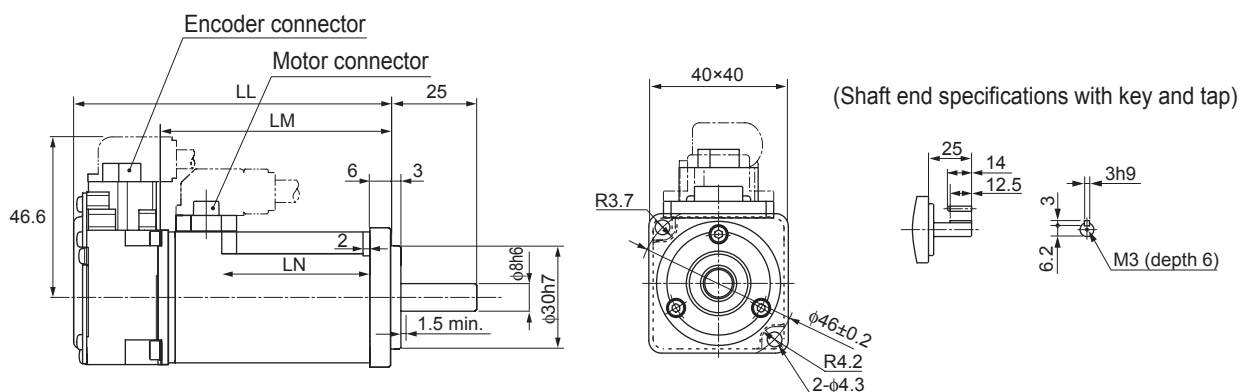

Model	Dimensions (mm)		
	LL	LM	LN
R88M-K05030□	72	48	23
R88M-K10030□	92	68	43

Note The standard models have a straight shaft. Models with a key and tap are indicated with S2 at the end of the model number.
 Models with an oil seal are indicated with O at the end of the model number. The motor dimensions do not change.

● 50 W/100 W (with Brake)

R88M-K05030H-B (S2)/-K10030□-B (S2) **INC**

R88M-K05030T-B (S2)/-K10030□-B (S2) **ABS**

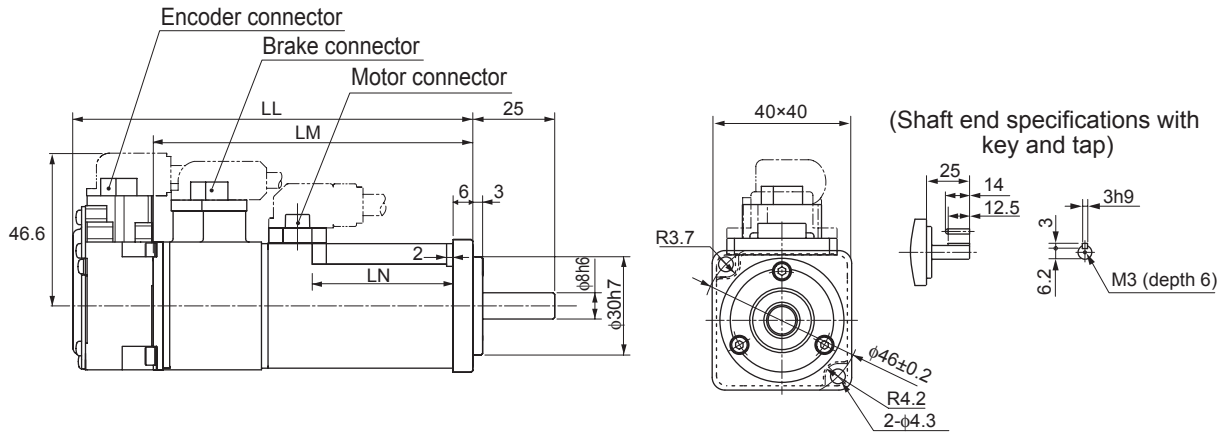

Model	Dimensions (mm)		
	LL	LM	LN
R88M-K05030□-B□	102	78	23
R88M-K10030□-B□	122	98	43

Note The standard models have a straight shaft. Models with a key and tap are indicated with S2 at the end of the model number.
Models with an oil seal are indicated with O at the end of the model number. The motor dimensions do not change.

● 200 W/400 W (without Brake)

R88M-K20030□ (-S2)/-K40030□ (-S2) **INC**

R88M-K20030□ (-S2)/-K40030□ (-S2) **ABS**

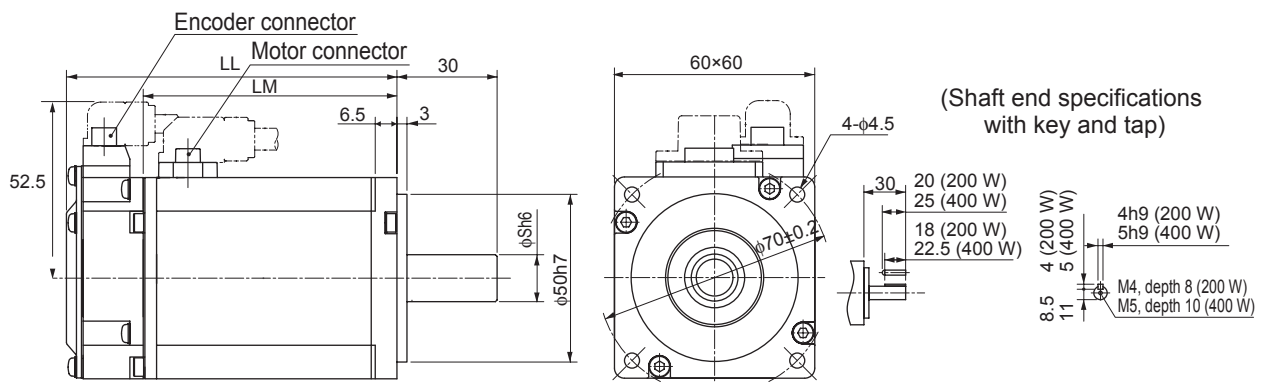

Model	Dimensions (mm)		
	LL	LM	S
R88M-K20030□	79.5	56.5	11
R88M-K40030□	99	76	14

Note The standard models have a straight shaft. Models with a key and tap are indicated with S2 at the end of the model number.
Models with an oil seal are indicated with O at the end of the model number. The motor dimensions do not change.

● 200 W/400 W (with Brake)

R88M-K20030□-B (S2)/-K40030□-B (S2) **INC**

R88M-K20030□-B (S2)/-K40030□-B (S2) **ABS**

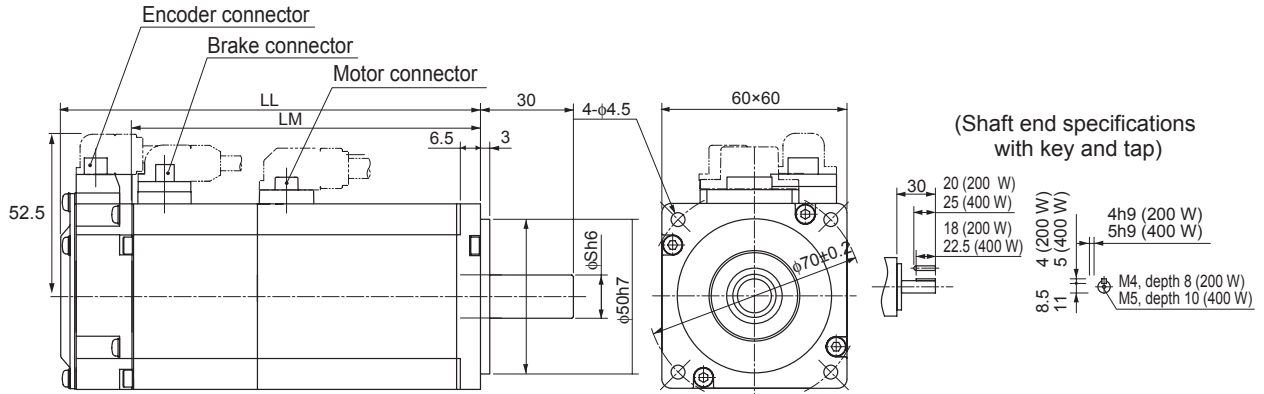

Model	Dimensions (mm)		
	LL	LM	S
R88M-K20030□-B□	116	93	11
R88M-K40030□-B□	135.5	112.5	14

Note The standard models have a straight shaft. Models with a key and tap are indicated with S2 at the end of the model number.
Models with an oil seal are indicated with O at the end of the model number. The motor dimensions do not change.

● 750 W (without Brake)

R88M-K75030H (-S2) **INC**

R88M-K75030T (-S2) **ABS**

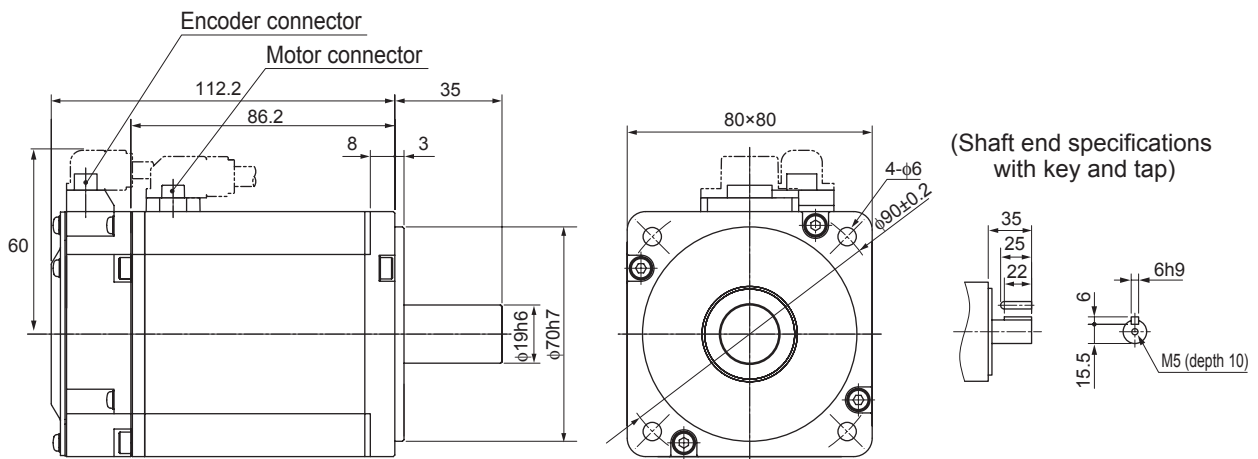

Note The standard models have a straight shaft. Models with a key and tap are indicated with S2 at the end of the model number.
Models with an oil seal are indicated with O at the end of the model number. The motor dimensions do not change.

● 750 W (with Brake)

R88M-K75030H-B (S2) **INC**

R88M-K75030T-B (S2) **ABS**

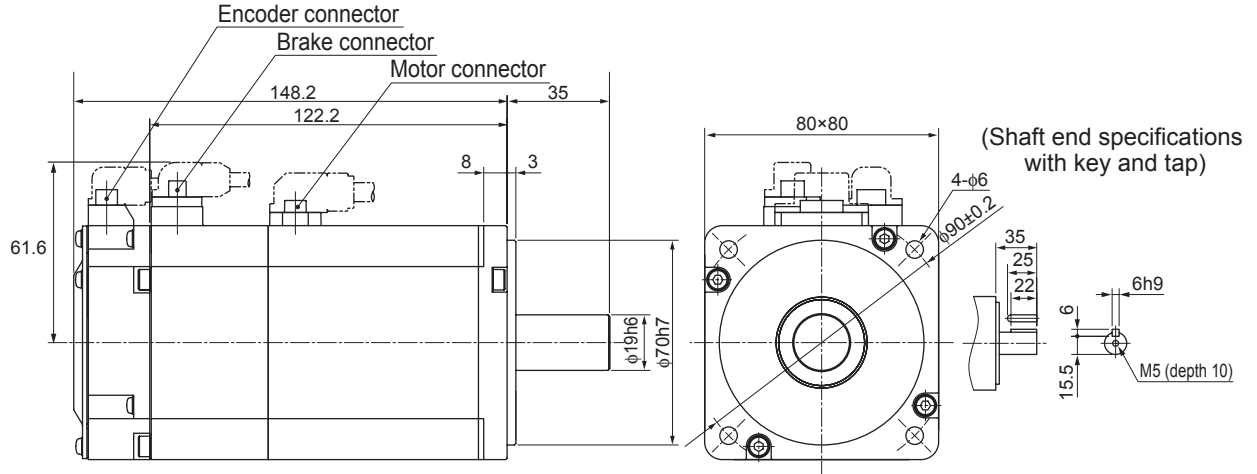

Note The standard models have a straight shaft. Models with a key and tap are indicated with S2 at the end of the model number.
Models with an oil seal are indicated with O at the end of the model number. The motor dimensions do not change.

● 1 kW/1.5 kW/2 kW (without Brake)

R88M-K1K030H (-S2)/-K1K530H (-S2)/-K2K030H (-S2) **INC**

R88M-K1K030T (-S2)/-K1K530T (-S2)/-K2K030T (-S2) **ABS**

● 1 kW/1.5 kW/2 kW (with Brake)

R88M-K1K030H-B (S2)/-K1K530H-B (S2)/-K2K030H-B (-S2) **INC**

R88M-K1K030T-B (S2)/-K1K530T-B (S2)/-K2K030T-B (-S2) **ABS**

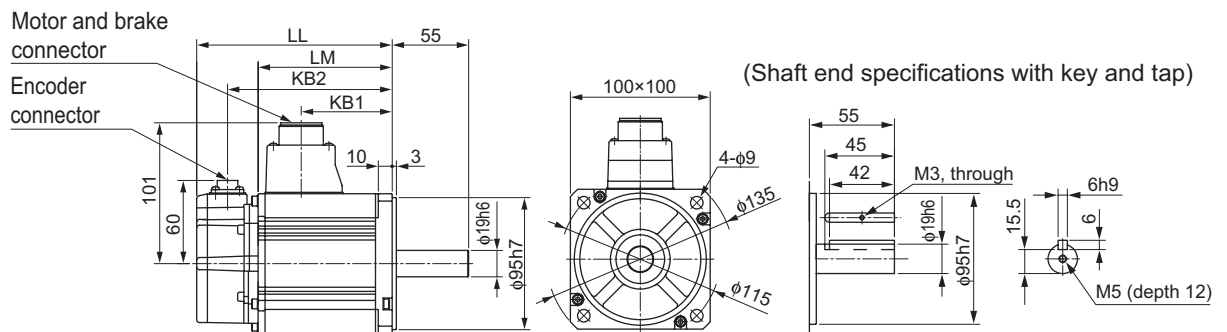

Model	Dimensions (mm)			
	LL	LM	KB1	KB2
R88M-K1K030□	141	97	66	119
R88M-K1K530□	159.5	115.5	84.5	137.5
R88M-K2K030□	178.5	134.5	103.5	156.5
R88M-K1K030□-B□	168	124	66	146
R88M-K1K530□-B□	186.5	142.5	84.5	164.5
R88M-K2K030□-B□	205.5	161.5	103.5	183.5

Note The standard models have a straight shaft. Models with a key and tap are indicated with S2 at the end of the model number.
Models with an oil seal are indicated with O at the end of the model number. The motor dimensions do not change.

● 3 kW (without Brake)

R88M-K3K030H (-S2) **INC**

R88M-K3K030T (-S2) **ABS**

● 3 kW (with Brake)

R88M-K3K030H-B (S2) **INC**

R88M-K3K030T-B (S2) **ABS**

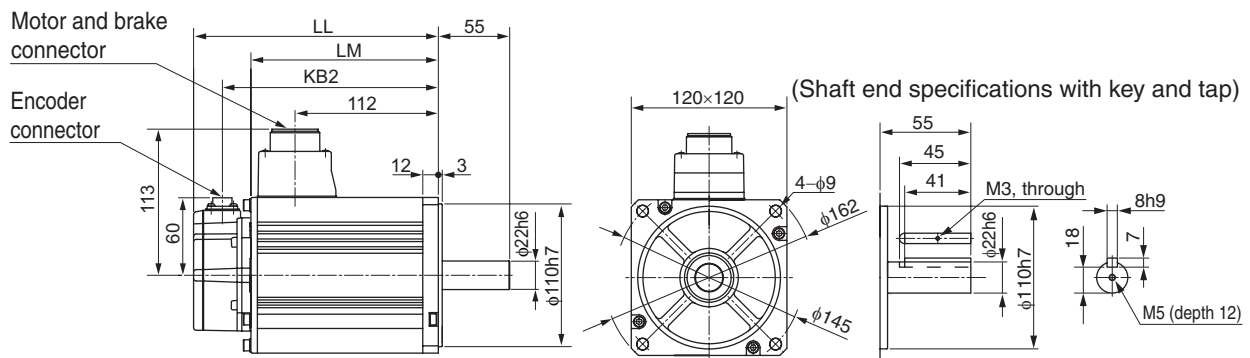

Model	Dimensions (mm)		
	LL	LM	KB2
R88M-K3K030□	190	146	168
R88M-K3K030□-B□	215	171	193

Note The standard models have a straight shaft. Models with a key and tap are indicated with S2 at the end of the model number.
Models with an oil seal are indicated with O at the end of the model number. The motor dimensions do not change.

● 4 kW/5 kW (without Brake)

R88M-K4K030H (-S2)/-K5K030H (-S2) **INC**

R88M-K4K030T (-S2)/-K5K030T (-S2) **ABS**

● 4 kW/5 kW (with Brake)

R88M-K4K030H-B (S2)/-K5K030H-B (S2) **INC**

R88M-K4K030T-B (S2)/-K5K030T-B (S2) **ABS**

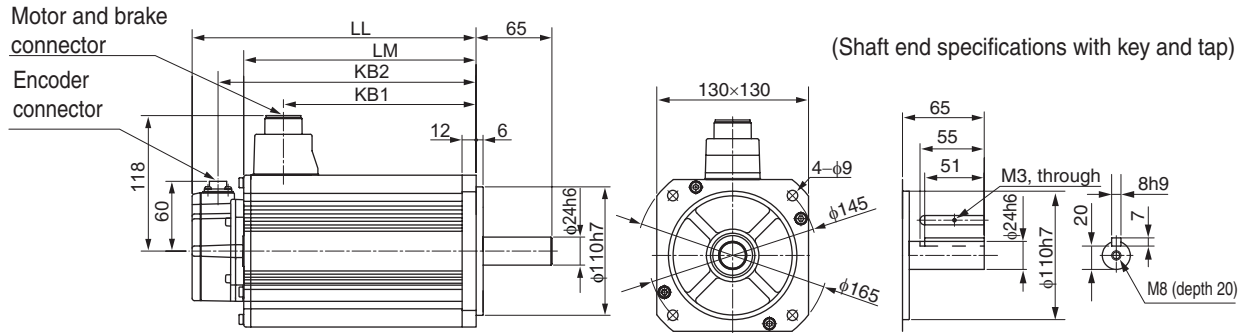

Model	Dimensions (mm)			
	LL	LM	KB1	KB2
R88M-K4K030□	208	164	127	186
R88M-K5K030□	243	199	162	221
R88M-K4K030□-B□	236	192	127	214
R88M-K5K030□-B□	271	227	162	249

Note The standard models have a straight shaft. Models with a key and tap are indicated with S2 at the end of the model number.
 Models with an oil seal are indicated with O at the end of the model number. The motor dimensions do not change.

3,000-r/min Servomotors (400 V)

● 750 W/1 kW/1.5 kW/2 kW (without Brake)

R88M-K75030F (-S2)/-K1K030F (-S2)/-K1K530F (-S2)/-K2K030F (-S2) **INC**

R88M-K75030C (-S2)/-K1K030C (-S2)/-K1K530C (-S2)/-K2K030C (-S2) **ABS**

● 750 W/1 kW/1.5 kW/2 kW (with Brake)

R88M-K75030F-B (S2)/-K1K030F-B (S2)/-K1K530F-B (S2)/-K2K030F-B (-S2) **INC**

R88M-K75030C-B (S2)/-K1K030C-B (S2)/-K1K530C-B (S2)/-K2K030C-B (-S2) **ABS**

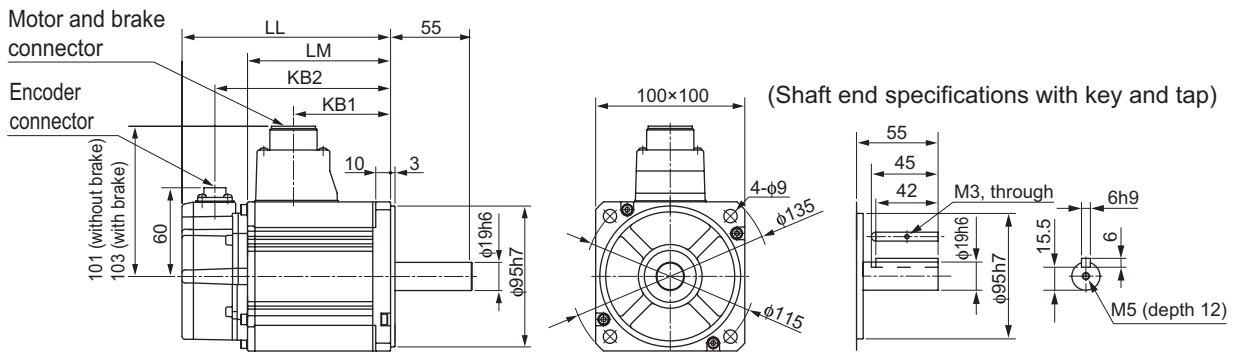

Model	Dimensions (mm)			
	LL	LM	KB1	KB2
R88M-K75030□	131.5	87.5	56.5	109.5
R88M-K1K030□	141	97	66	119
R88M-K1K530□	159.5	115.5	84.5	137.5
R88M-K2K030□	178.5	134.5	103.5	156.5
R88M-K75030□-B□	158.5	114.5	53.5	136.5
R88M-K1K030□-B□	168	124	63	146
R88M-K1K530□-B□	186.5	142.5	81.5	164.5
R88M-K2K030□-B□	205.5	161.5	100.5	183.5

Note The standard models have a straight shaft. Models with a key and tap are indicated with S2 at the end of the model number.

Models with an oil seal are indicated with O at the end of the model number. The motor dimensions do not change.

● **3 kW (without Brake)**

R88M-K3K030F (-S2) **INC**

R88M-K3K030C (-S2) **ABS**

● **3 kW (with Brake)**

R88M-K3K030F-B (S2) **INC**

R88M-K3K030C-B (S2) **ABS**

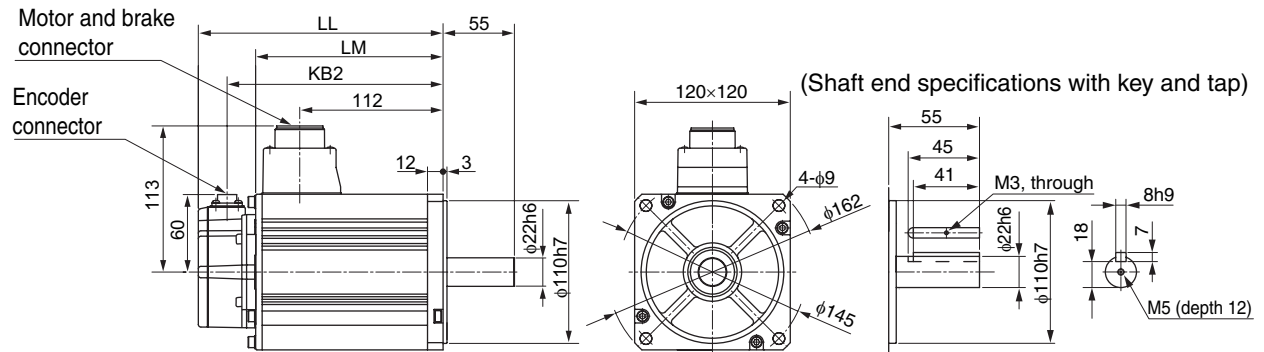

Model	Dimensions (mm)		
	LL	LM	KB2
R88M-K3K030□	190	146	168
R88M-K3K030□-B□	215	171	193

Note The standard models have a straight shaft. Models with a key and tap are indicated with S2 at the end of the model number.

Models with an oil seal are indicated with O at the end of the model number. The motor dimensions do not change.

● 4 kW/5 kW (without Brake)

R88M-K4K030F (-S2)/-K5K030F (-S2) **INC**

R88M-K4K030C (-S2)/-K5K030C (-S2) **ABS**

● 4 kW/5 kW (with Brake)

R88M-K4K030F-B (S2)/-K5K030F-B (S2) **INC**

R88M-K4K030C-B (S2)/-K5K030C-B (S2) **ABS**

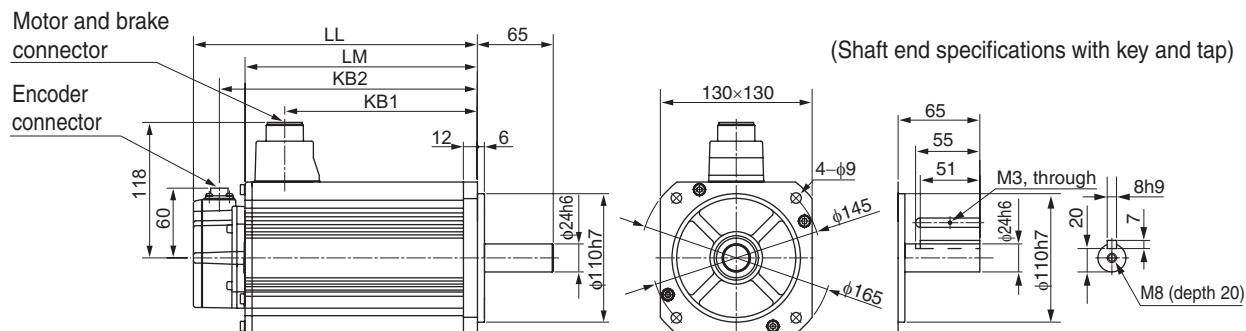

Model	Dimensions (mm)			
	LL	LM	KB1	KB2
R88M-K4K030□	208	164	127	186
R88M-K5K030□	243	199	162	221
R88M-K4K030□-B□	236	192	127	214
R88M-K5K030□-B□	271	227	162	249

Note The standard models have a straight shaft. Models with a key and tap are indicated with S2 at the end of the model number.

Models with an oil seal are indicated with O at the end of the model number. The motor dimensions do not change.

1,500-r/min and 2,000-r/min Servomotors (200 V)

● 1 kW/1.5 kW/2 kW/3 kW (without Brake)

R88M-K1K020H (-S2)/-K1K520H (-S2)/-K2K020H (-S2)/-K3K020H (-S2) **INC**

R88M-K1K020T (-S2)/-K1K520T (-S2)/-K2K020T (-S2)/-K3K020T (-S2) **ABS**

● 1 kW/1.5 kW/2 kW/3 kW (with Brake)

R88M-K1K020H-B (S2)/-K1K520H-B (S2)/-K2K020H-B (S2)/-K3K020H-B (S2) **INC**

R88M-K1K020T-B (S2)/-K1K520T-B (S2)/-K2K020T-B (S2)/-K3K020T-B (S2) **ABS**

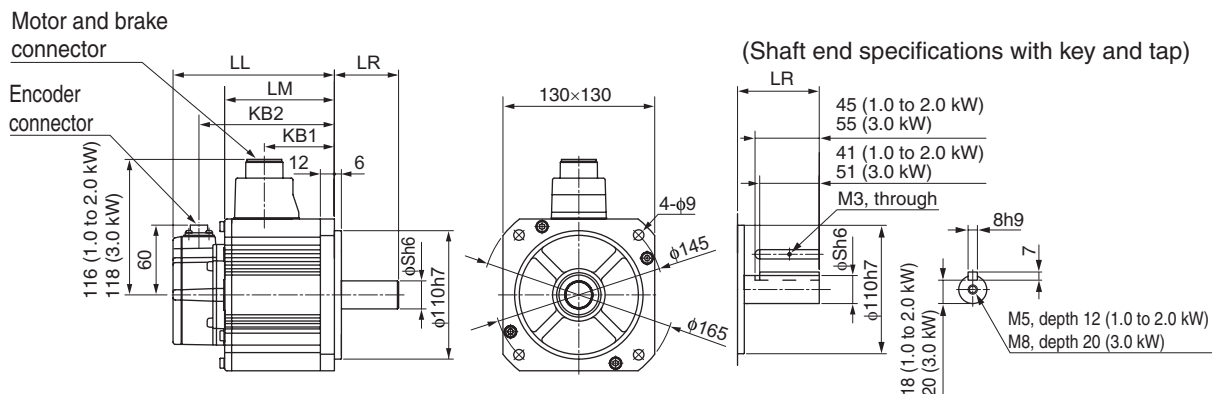

Model	Dimensions (mm)					
	LL	LR	LM	S	KB1	KB2
R88M-K1K020□	138	55	94	22	60	116
R88M-K1K520□	155.5	55	111.5	22	77.5	133.5
R88M-K2K020□	173	55	129	22	95	151
R88M-K3K020□	208	65	164	24	127	186
R88M-K1K020□-B□	166	55	122	22	60	144
R88M-K1K520□-B□	183.5	55	139.5	22	77.5	161.5
R88M-K2K020□-B□	201	55	157	22	95	179
R88M-K3K020□-B□	236	65	192	24	127	214

Note The standard models have a straight shaft. Models with a key and tap are indicated with S2 at the end of the model number.

Models with an oil seal are indicated with O at the end of the model number. The motor dimensions do not change.

● 4 kW/5 kW (without Brake)

R88M-K4K020H (-S2)/-K5K020H (-S2) **INC**

R88M-K4K020T (-S2)/-K5K020T (-S2) **ABS**

● 4 kW/5 kW (with Brake)

R88M-K4K020H-B (S2)/-K5K020H-B (S2) **INC**

R88M-K4K020T-B (S2)/-K5K020T-B (S2) **ABS**

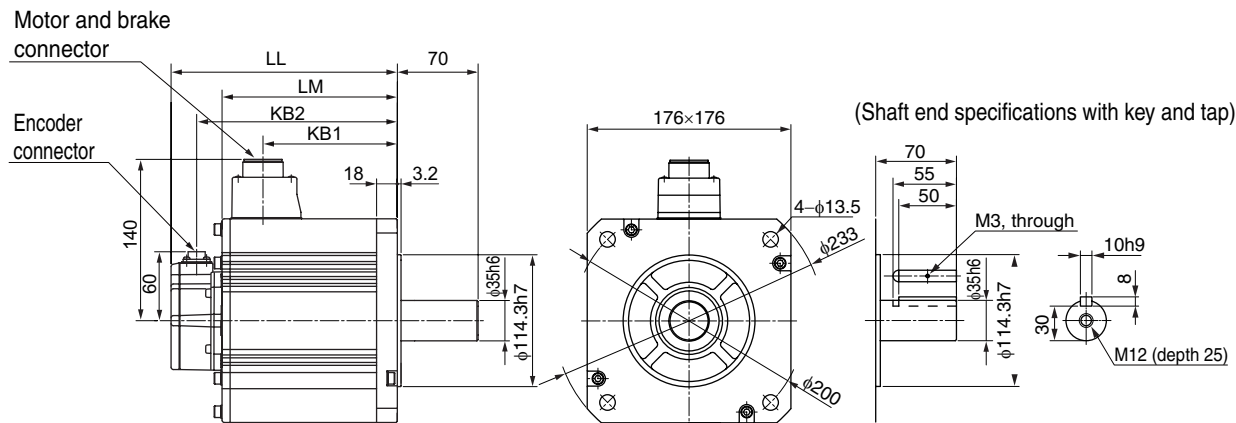

Model	Dimensions (mm)			
	LL	LM	KB1	KB2
R88M-K4K020□	177	133	96	155
R88M-K5K020□	196	152	115	174
R88M-K4K020□-B□	206	162	96	184
R88M-K5K020□-B□	225	181	115	203

Note The standard models have a straight shaft. Models with a key and tap are indicated with S2 at the end of the model number.
 Models with an oil seal are indicated with O at the end of the model number. The motor dimensions do not change.

● 7.5 kW (without Brake)

R88M-K7K515T (-S2) **ABS**

● 7.5 kW (with Brake)

R88M-K7K515T-B (S2) **ABS**

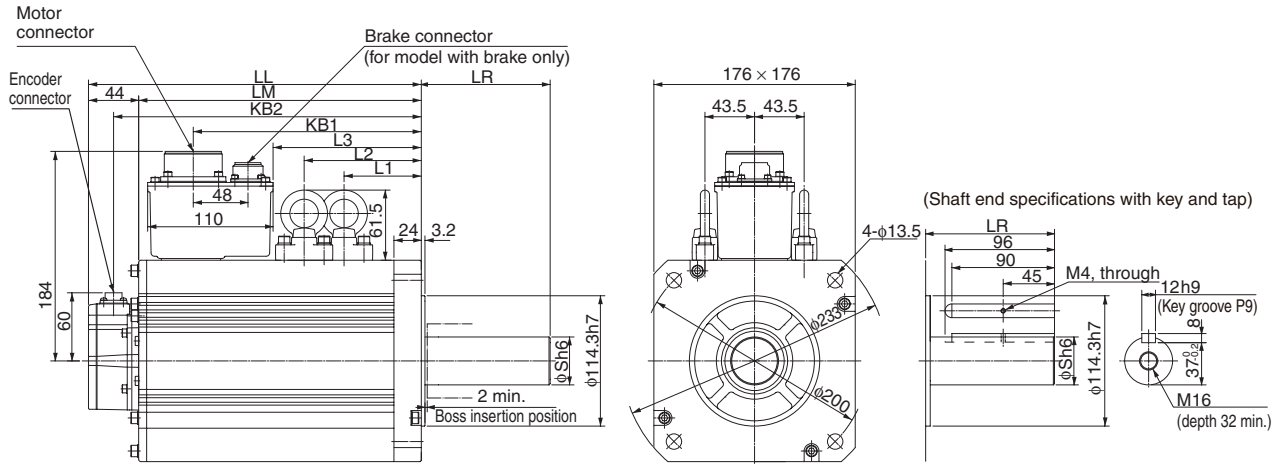

Model	Dimensions (mm)								
	LL	LR	LM	S	KB1	KB2	L1	L2	L3
R88M-K7K515T□	312	113	268	42	219	290	117.5	117.5	149
R88M-K7K515T-B□	337	113	293	42	253	315	117.5	152.5	183

Note The standard models have a straight shaft. Models with a key and tap are indicated with S2 at the end of the model number.

Models with an oil seal are indicated with O at the end of the model number. The motor dimensions do not change.

● 11 kW/15 kW (without Brake)

R88M-K11K015T (-S2)/-K15K015T (-S2) **ABS**

● 11 kW/15 kW (with Brake)

R88M-K11K015T-B (S2)/R88M-K15K015T-B (S2) **ABS**

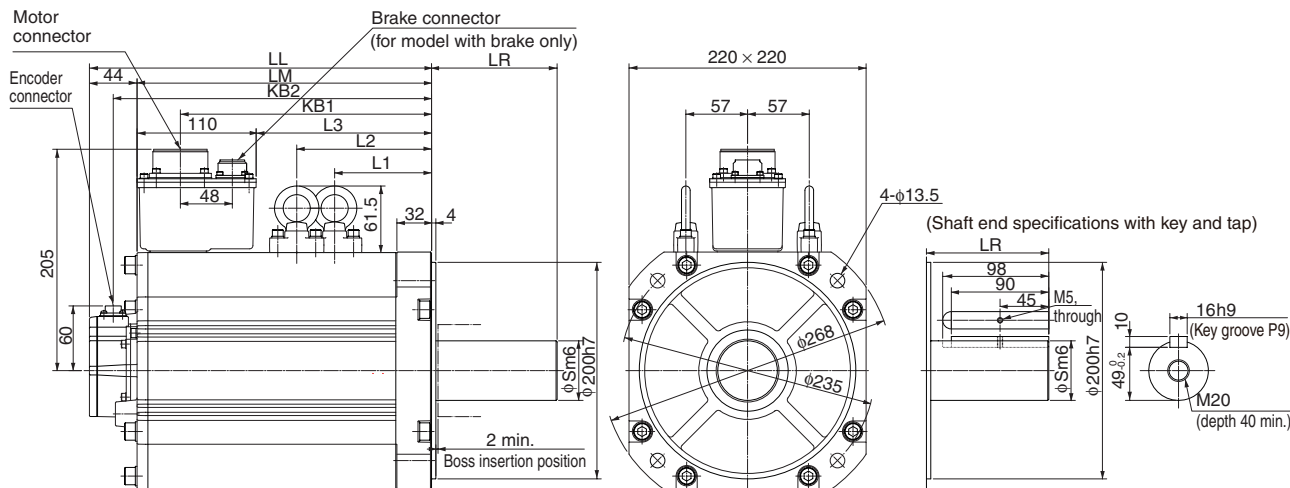

Model	Dimensions (mm)								
	LL	LR	LM	S	KB1	KB2	L1	L2	L3
R88M-K11K015T□	316	116	272	55	232	294	124.5	124.5	162
R88M-K15K015T□	384	116	340	55	300	362	158.5	158.5	230
R88M-K11K015T-B□	364	116	320	55	266	342	124.5	159.5	196
R88M-K15K015T-B□	432	116	388	55	334	410	158.5	193.5	264

Note The standard models have a straight shaft. Models with a key and tap are indicated with S2 at the end of the model number.
 Models with an oil seal are indicated with O at the end of the model number. The motor dimensions do not change.

1,500-r/min and 2,000-r/min Servomotors (400 V)

● 400 W/600 W (without Brake)

R88M-K40020F (-S2)/-K60020F (-S2) **INC**

R88M-K40020C (-S2)/-K60020C (-S2) **ABS**

● 400 W/600 W (with Brake)

R88M-K40020F-B (S2)/-K60020F-B (S2) **INC**

R88M-K40020C-B (S2)/-K60020C-B (S2) **ABS**

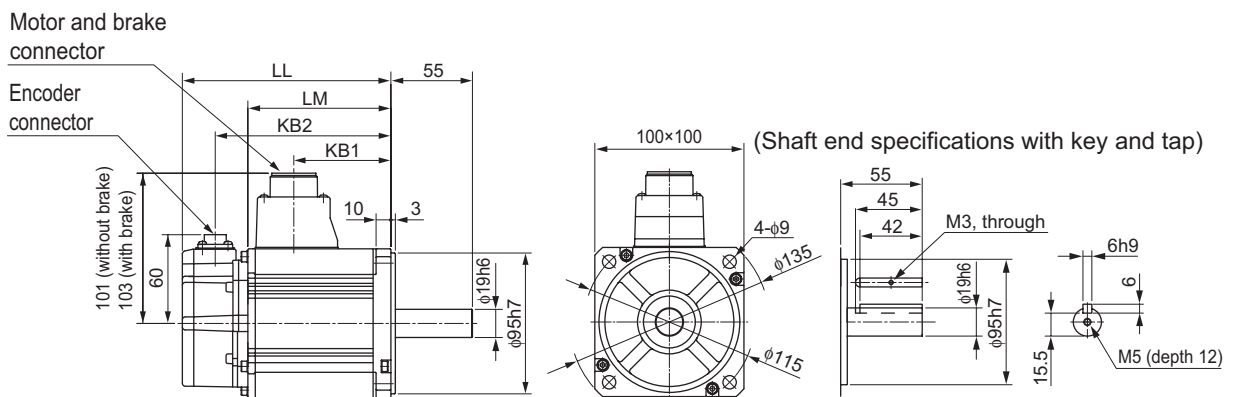

Model	Dimensions (mm)			
	LL	LM	KB1	KB2
R88M-K40020□	131.5	87.5	56.5	109.5
R88M-K60020□	141	97	66	119
R88M-K40020□-B□	158.5	114.5	53.5	136.5
R88M-K60020□-B□	168	124	63	146

Note The standard models have a straight shaft. Models with a key and tap are indicated with S2 at the end of the model number.

Models with an oil seal are indicated with O at the end of the model number. The motor dimensions do not change.

● 1 kW/1.5 kW/2 kW/3 kW (without Brake)

R88M-K1K020F (-S2)/-K1K520F (-S2)/-K2K020F (-S2)/-K3K020F (-S2) **INC**

R88M-K1K020C (-S2)/-K1K520C (-S2)/-K2K020C (-S2)/-K3K020C (-S2) **ABS**

● 1 kW/1.5 kW/2 kW/3 kW (with Brake)

R88M-K1K020F-B (S2)/-K1K520F-B (S2)/-K2K020F-B (S2)/-K3K020F-B (S2) **INC**

R88M-K1K020C-B (S2)/-K1K520C-B (S2)/-K2K020C-B (S2)/-K3K020C-B (S2) **ABS**

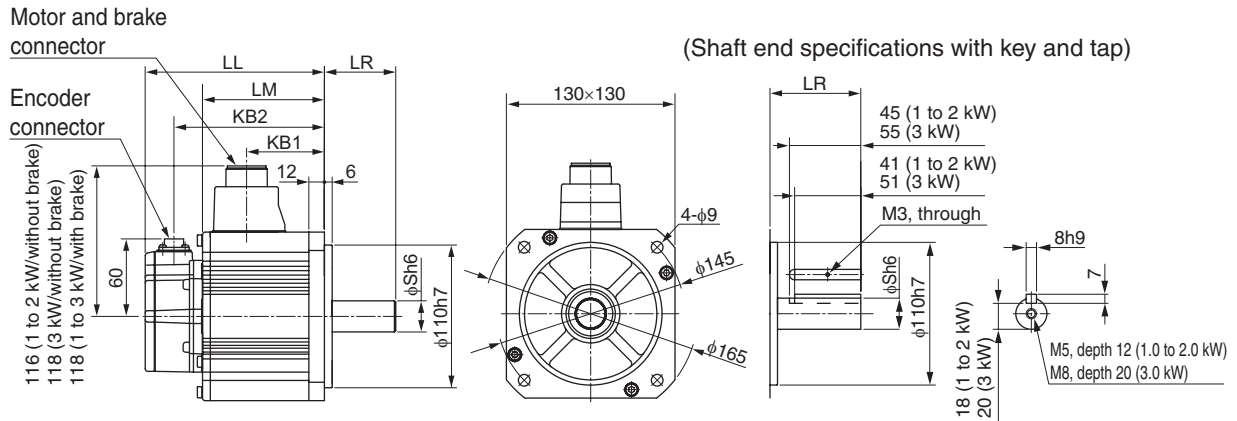

Model	Dimensions (mm)					
	LL	LR	LM	S	KB1	KB2
R88M-K1K020□	138	55	94	22	60	116
R88M-K1K520□	155.5	55	111.5	22	77.5	133.5
R88M-K2K020□	173	55	129	22	95	151
R88M-K3K020□	208	65	164	24	127	186
R88M-K1K020□-B□	166	55	122	22	57	144
R88M-K1K520□-B□	183.5	55	139.5	22	74.5	161.5
R88M-K2K020□-B□	201	55	157	22	92	179
R88M-K3K020□-B□	236	65	192	24	127	214

Note The standard models have a straight shaft. Models with a key and tap are indicated with S2 at the end of the model number.
Models with an oil seal are indicated with O at the end of the model number. The motor dimensions do not change.

● 4 kW/5 kW (without Brake)

R88M-K4K020F (-S2)/-K5K020F (-S2) **INC**

R88M-K4K020C (-S2)/-K5K020C (-S2) **ABS**

● 4 kW/5 kW (with Brake)

R88M-K4K020F-B (S2)/-K5K020F-B (S2) **INC**

R88M-K4K020C-B (S2)/-K5K020C-B (S2) **ABS**

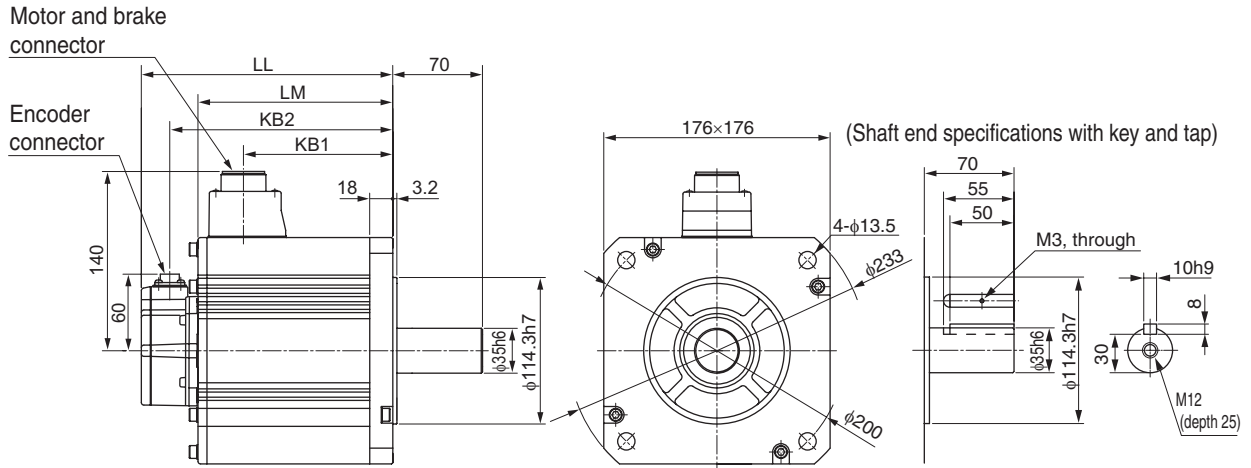

Model	Dimensions (mm)			
	LL	LM	KB1	KB2
R88M-K4K020□	177	133	96	155
R88M-K5K020□	196	152	115	174
R88M-K4K020□-B□	206	162	96	184
R88M-K5K020□-B□	225	181	115	203

Note The standard models have a straight shaft. Models with a key and tap are indicated with S2 at the end of the model number.

Models with an oil seal are indicated with O at the end of the model number. The motor dimensions do not change.

● 7.5 kW (without Brake)

R88M-K7K515C (-S2) **ABS**

● 7.5 kW (with Brake)

R88M-K7K515C-B (S2) **ABS**

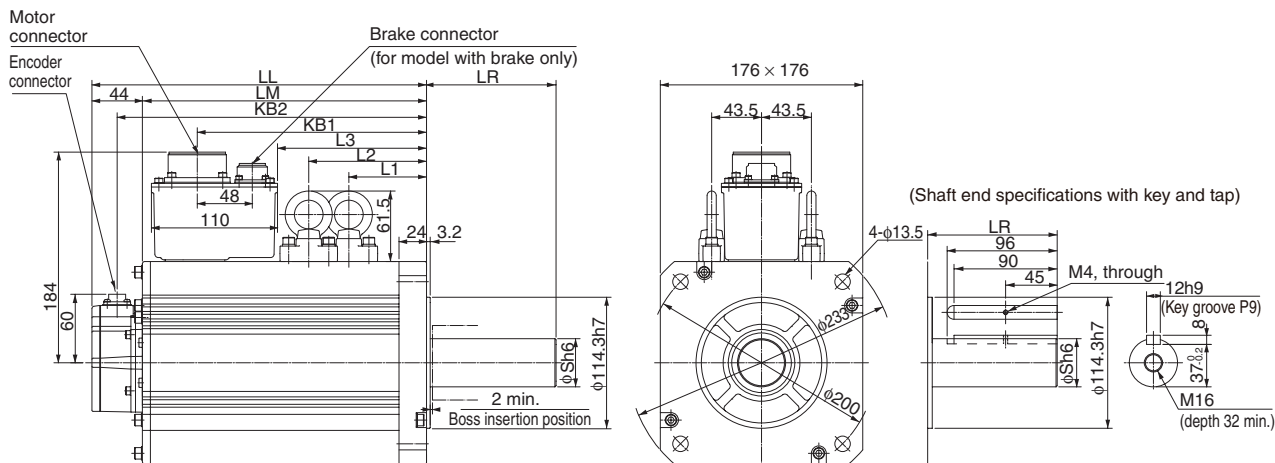

Model	Dimensions (mm)								
	LL	LR	LM	S	KB1	KB2	L1	L2	L3
R88M-K7K515C□	312	113	268	42	219	290	117.5	117.5	149
R88M-K7K515C-B□	337	113	293	42	253	315	117.5	152.5	183

Note The standard models have a straight shaft. Models with a key and tap are indicated with S2 at the end of the model number.
 Models with an oil seal are indicated with O at the end of the model number. The motor dimensions do not change.

● 11 kW/15 kW (without Brake)

R88M-K11K015C (-S2)/-K15K015C (-S2) **ABS**

● 11 kW/15 kW (with Brake)

R88M-K11K015C-B (S2)/R88M-K15K015C-B (S2) **ABS**

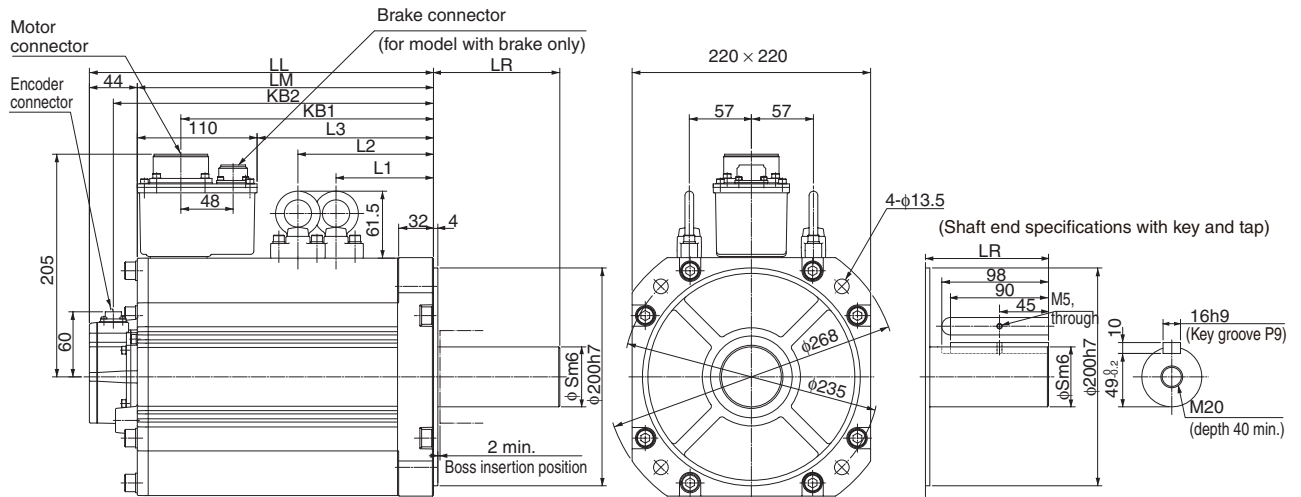

Model	Dimensions (mm)								
	LL	LR	LM	S	KB1	KB2	L1	L2	L3
R88M-K11K015C□	316	116	272	55	232	294	124.5	124.5	162
R88M-K15K015C□	384	116	340	55	300	362	158.5	158.5	230
R88M-K11K015C-B□	364	116	320	55	266	342	124.5	159.5	196
R88M-K15K015C-B□	432	116	388	55	334	410	158.5	193.5	264

Note The standard models have a straight shaft. Models with a key and tap are indicated with S2 at the end of the model number.

Models with an oil seal are indicated with O at the end of the model number. The motor dimensions do not change.

1,000-r/min Servomotors (200 V)

● 900 W (without Brake)

R88M-K90010H (-S2) **INC**

R88M-K90010T (-S2) **ABS**

● 900 W (with Brake)

R88M-K90010H-B (S2) **INC**

R88M-K90010T-B (S2) **ABS**

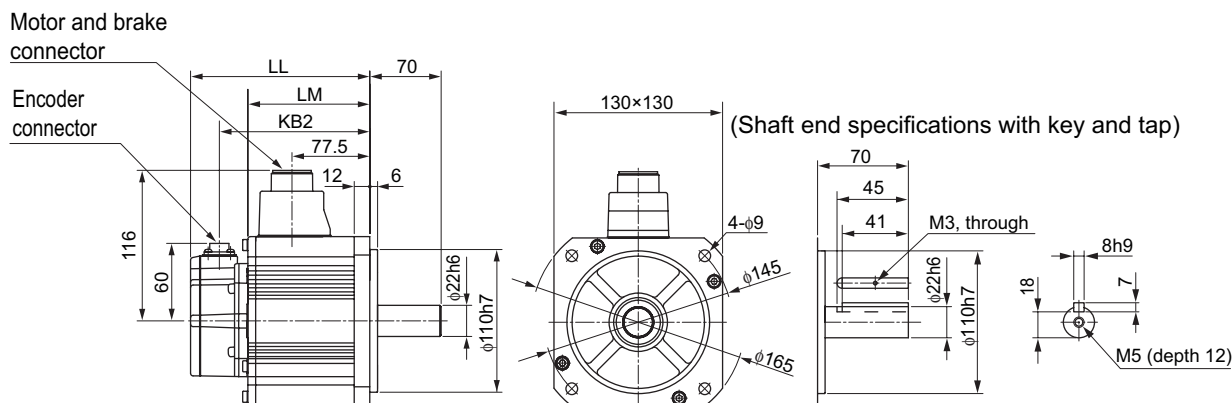

Model	Dimensions (mm)		
	LL	LM	KB2
R88M-K90010□	155.5	111.5	133.5
R88M-K90010□-B□	183.5	139.5	161.5

Note The standard models have a straight shaft. Models with a key and tap are indicated with S2 at the end of the model number.
Models with an oil seal are indicated with O at the end of the model number. The motor dimensions do not change.

● 2 kW/3 kW (without Brake)

R88M-K2K010H (-S2)/-K3K010H (-S2) **INC**

R88M-K2K010T (-S2)/-K3K010T (-S2) **ABS**

● 2 kW/3 kW (with Brake)

R88M-K2K010H-B (S2)/-K3K010H-B (S2) **INC**

R88M/-K2K010T-B (S2)/-K3K010T-B (S2) **ABS**

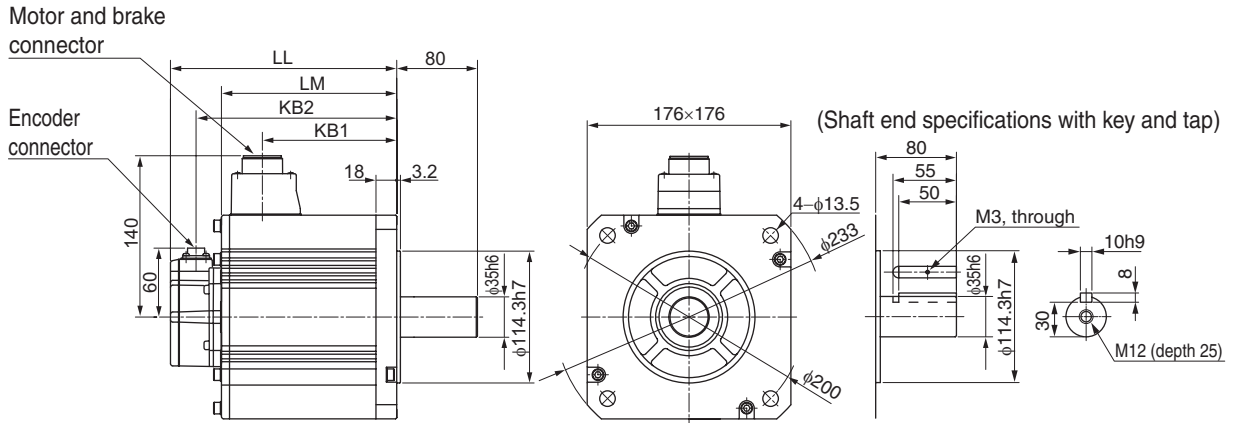

Model	Dimensions (mm)			
	LL	LM	KB1	KB2
R88M-K2K010□	163.5	119.5	82.5	141.5
R88M-K3K010□	209.5	165.5	128.5	187.5
R88M-K2K010□-B□	192.5	148.5	82.5	170.5
R88M-K3K010□-B□	238.5	194.5	128.5	216.5

Note The standard models have a straight shaft. Models with a key and tap are indicated with S2 at the end of the model number.
Models with an oil seal are indicated with O at the end of the model number. The motor dimensions do not change.

● 4.5 kW (without Brake)

R88M-K4K510T (-S2) **ABS**

● 4.5 kW (with Brake)

R88M-K4K510T-B (S2) **ABS**

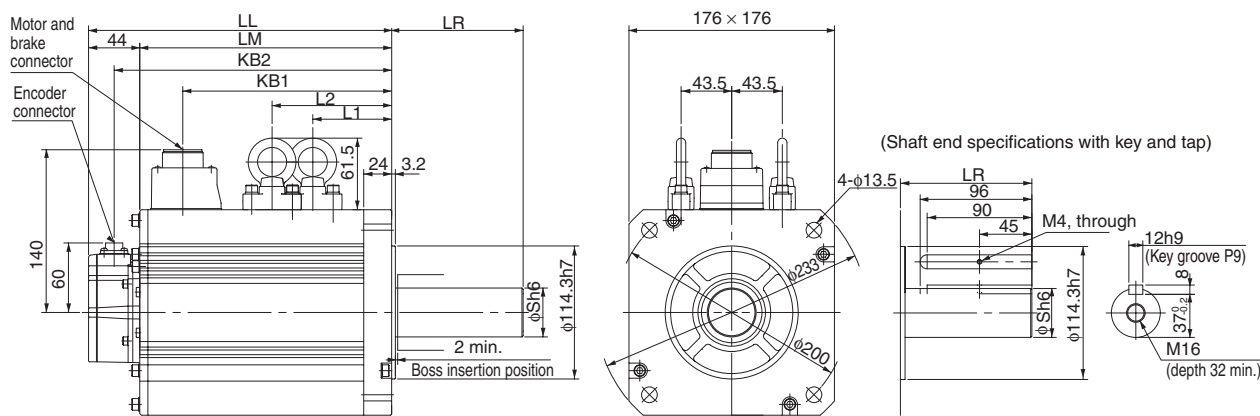

Model	Dimensions (mm)							
	LL	LR	LM	S	KB1	KB2	L1	L2
R88M-K4K510T□	266	113	222	42	185	244	98	98
R88M-K4K510T-B□	291	113	247	42	185	269	98	133

Note The standard models have a straight shaft. Models with a key and tap are indicated with S2 at the end of the model number.

Models with an oil seal are indicated with O at the end of the model number. The motor dimensions do not change.

● 6 kW (without Brake)

R88M-K6K010T (-S2) **ABS**

● 6 kW (with Brake)

R88M-K6K010T-B (S2) **ABS**

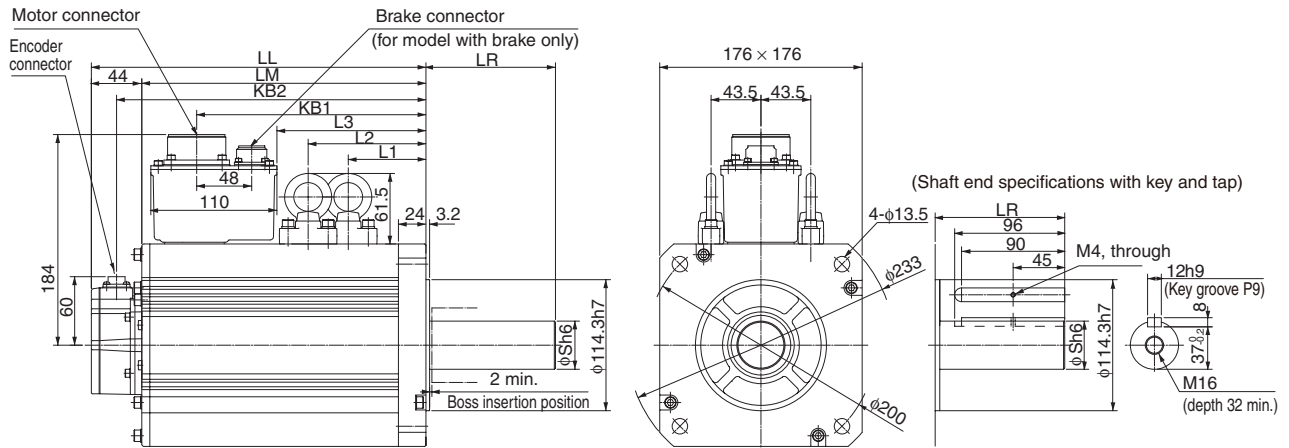

Model	Dimensions (mm)								
	LL	LR	LM	S	KB1	KB2	L1	L2	L3
R88M-K6K010T□	312	113	268	42	219	290	117.5	117.5	149
R88M-K6K010T-B□	337	113	293	42	253	315	117.5	152.5	183

Note The standard models have a straight shaft. Models with a key and tap are indicated with S2 at the end of the model number.
 Models with an oil seal are indicated with O at the end of the model number. The motor dimensions do not change.

1,000-r/min Servomotors (400 V)

● 900 W (without Brake)

R88M-K90010F (-S2) **INC**

R88M-K90010C (-S2) **ABS**

● 900 W (with Brake)

R88M-K90010F-B (S2) **INC**

R88M-K90010C-B (S2) **ABS**

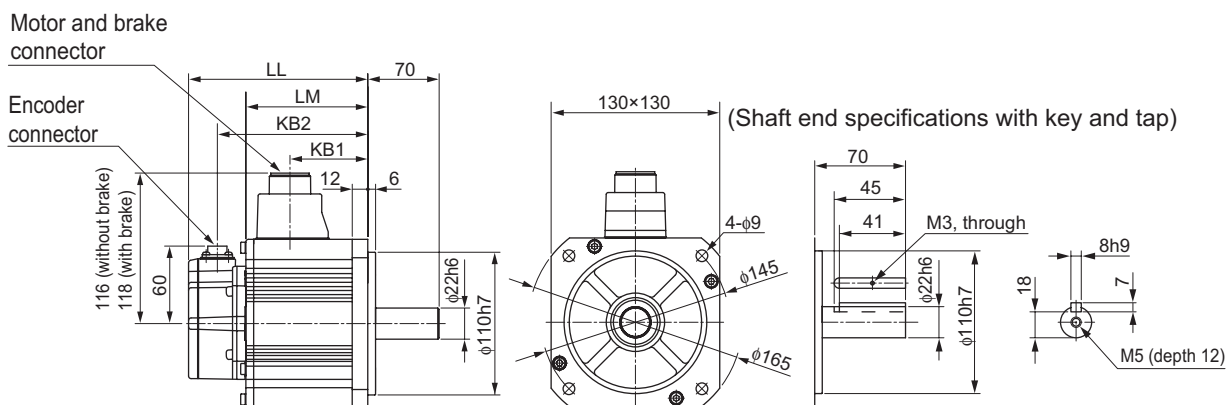

Model	Dimensions (mm)			
	LL	LM	KB1	KB2
R88M-K90010□	155.5	111.5	77.5	133.5
R88M-K90010□-B□	183.5	139.5	74.5	161.5

Note The standard models have a straight shaft. Models with a key and tap are indicated with S2 at the end of the model number.
Models with an oil seal are indicated with O at the end of the model number. The motor dimensions do not change.

● 2 kW/3 kW (without Brake)

R88M-K2K010F (-S2)/-K3K010F (-S2) **INC**

R88M-K2K010C (-S2)/-K3K010C (-S2) **ABS**

● 2 kW/3 kW (with Brake)

R88M-K2K010F-B (S2)/-K3K010F-B (S2) **INC**

R88M-K2K010C-B (S2)/-K3K010C-B (S2) **ABS**

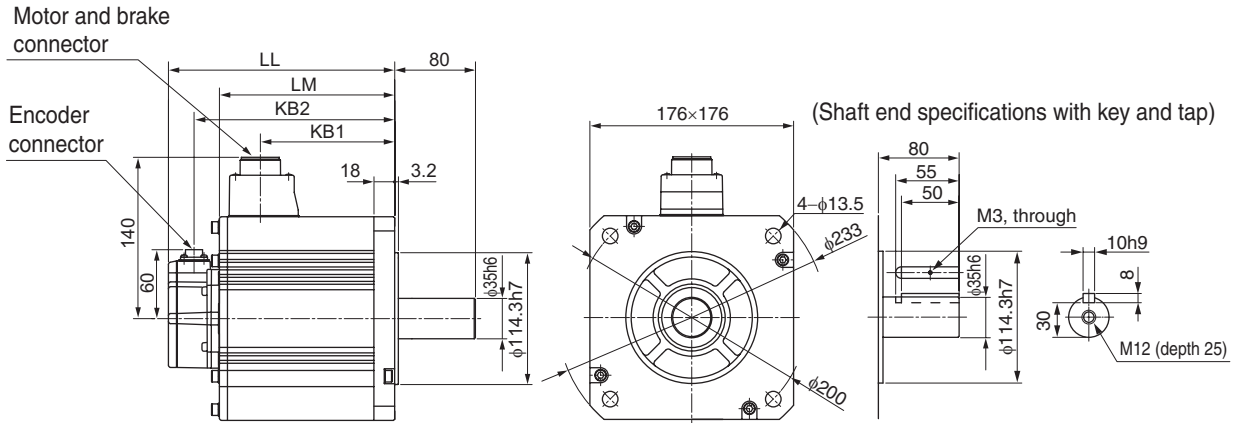

Model	Dimensions (mm)			
	LL	LM	KB1	KB2
R88M-K2K010□	163.5	119.5	82.5	141.5
R88M-K3K010□	209.5	165.5	128.5	187.5
R88M-K2K010□-B□	192.5	148.5	82.5	170.5
R88M-K3K010□-B□	238.5	194.5	128.5	216.5

Note The standard models have a straight shaft. Models with a key and tap are indicated with S2 at the end of the model number.
 Models with an oil seal are indicated with O at the end of the model number. The motor dimensions do not change.

● 4.5 kW (without Brake)

R88M-K4K510C (-S2) **ABS**

● 4.5 kW (with Brake)

R88M-K4K510C-B (S2) **ABS**

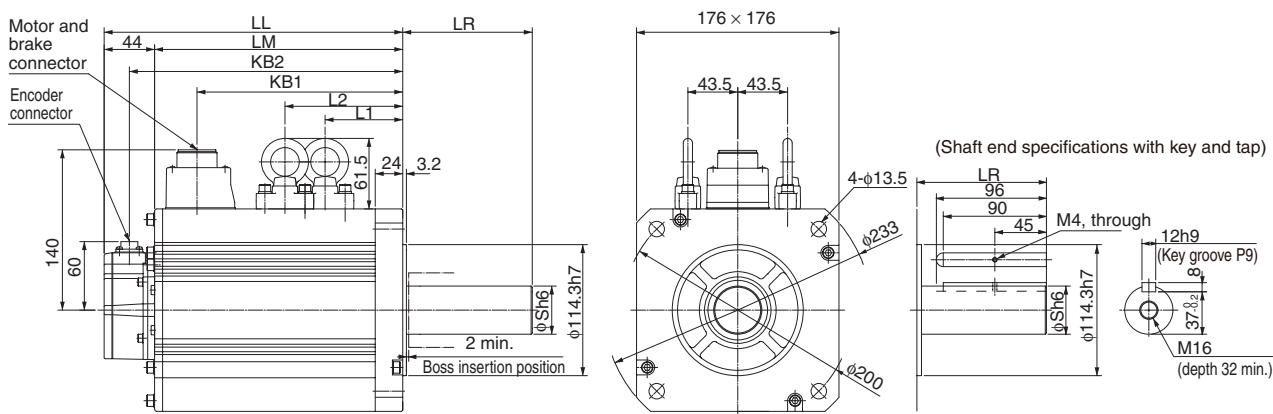

Model	Dimensions (mm)							
	LL	LR	LM	S	KB1	KB2	L1	L2
R88M-K4K510C□	266	113	222	42	185	244	98	98
R88M-K4K510C-B□	291	113	247	42	185	269	98	133

Note The standard models have a straight shaft. Models with a key and tap are indicated with S2 at the end of the model number.
 Models with an oil seal are indicated with O at the end of the model number. The motor dimensions do not change.

● 6 kW (without Brake)

R88M-K6K010C (-S2) **ABS**

● 6 kW (with Brake)

R88M-K6K010C-B (S2) **ABS**

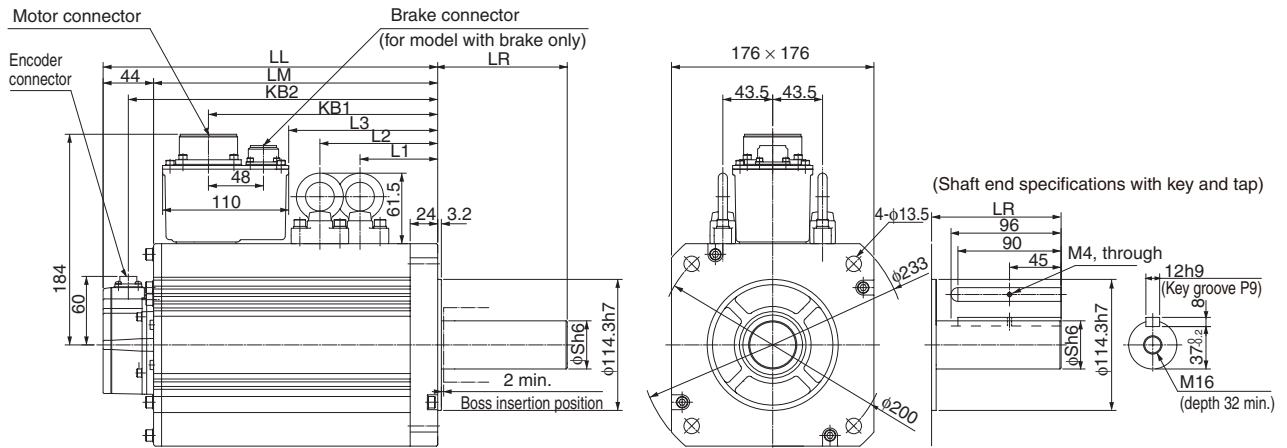

Model	Dimensions (mm)								
	LL	LR	LM	S	KB1	KB2	L1	L2	L3
R88M-K6K010C□	312	113	268	42	219	290	117.5	117.5	149
R88M-K6K010C-B□	337	113	293	42	253	315	117.5	152.5	183

Note The standard models have a straight shaft. Models with a key and tap are indicated with S2 at the end of the model number.
 Models with an oil seal are indicated with O at the end of the model number. The motor dimensions do not change.

2-4-3 Combinations of Servomotors and Reduction Gears

The tables in this section show the possible combinations of Servomotors and Reduction Gears by the rated motor rotation speed.

3,000-r/min Servomotors

Servomotor models	1/5	1/11 (1/9 for flange 11)	1/21	1/33	1/45
R88M-K05030□	R88G-HPG11B05100B□ (for both with R88M-K10030□)	R88G-HPG11B09050B□ (Reduction Ratio 1/9)	R88G-HPG14A21100B□ (for both with R88M-K10030□)	R88G-HPG14A33050B□	R88G-HPG14A45050B□
R88M-K10030□	R88G-HPG11B05100B□	R88G-HPG14A11100B□	R88G-HPG14A21100B□	R88G-HPG20A33100B□	R88G-HPG20A45100B□
R88M-K20030□	R88G-HPG14A05200B□	R88G-HPG14A11200B□	R88G-HPG20A21200B□	R88G-HPG20A33200B□	R88G-HPG20A45200B□
R88M-K40030□	R88G-HPG14A05400B□	R88G-HPG20A11400B□	R88G-HPG20A21400B□	R88G-HPG32A33400B□	R88G-HPG32A45400B□
R88M-K75030H/T (200V)	R88G-HPG20A05750B□	R88G-HPG20A11750B□	R88G-HPG32A21750B□	R88G-HPG32A33750B□	R88G-HPG32A45750B□
R88M-K75030F/C (400V)	R88G-HPG32A052K0B□ (for both with R88M-K2K030□)	R88G-HPG32A112K0B□ (for both with R88M-K2K030□)	R88G-HPG32A211K5B□ (for both with R88M-K1K5030□)	R88G-HPG32A33600SB□ (for both with R88M-K60020□)	R88G-HPG50A451K5B□ (for both with R88M-K1K5030□)
R88M-K1K030□	R88G-HPG32A052K0B□ (for both with R88M-K2K030□)	R88G-HPG32A112K0B□ (for both with R88M-K2K030□)	R88G-HPG32A211K5B□ (for both with R88M-K1K5030□)	R88G-HPG50A332K0B□ (for both with R88M-K2K030□)	R88G-HPG50A451K5B□ (for both with R88M-K1K5030□)
R88M-K1K530□	R88G-HPG32A052K0B□ (for both with R88M-K2K030□)	R88G-HPG32A112K0B□ (for both with R88M-K2K030□)	R88G-HPG32A211K5B□	R88G-HPG50A332K0B□ (for both with R88M-K2K030□)	R88G-HPG50A451K5B□
R88M-K2K030□	R88G-HPG32A052K0B□	R88G-HPG32A112K0B□	R88G-HPG50A212K0B□	R88G-HPG50A332K0B□	—
R88M-K3K030□	R88G-HPG32A053K0B□	R88G-HPG50A113K0B□	R88G-HPG50A213K0B□	—	—
R88M-K4K030□	R88G-HPG32A054K0B□	R88G-HPG50A115K0B□ (for both with R88M-K1K5030□)	—	—	—
R88M-K5K030□	R88G-HPG50A055K0B□	R88G-HPG50A115K0B□	—	—	—

2,000-r/min Servomotors

Servomotor models	1/5	1/11	1/21 (1/20 for flange 65)	1/33 (1/25 for flange 65)	1/45
R88M-K40020□ (only for 400 V)	R88G-HPG32A052K0B□ (for both with R88M-K2K030□)	R88G-HPG32A112K0B□ (for both with R88M-K2K030□)	R88G-HPG32A211K5B□ (for both with R88M-K1K5030□)	R88G-HPG32A33600SB□ (for both with R88M-K60020□)	R88G-HPG32A45400SB□
R88M-K60020□ (only for 400 V)	R88G-HPG32A052K0B□ (for both with R88M-K2K030□)	R88G-HPG32A112K0B□ (for both with R88M-K2K030□)	R88G-HPG32A211K5B□ (for both with R88M-K1K5030□)	R88G-HPG32A33600SB□	R88G-HPG50A451K5B□ (for both with R88M-K1K530□)
R88M-K1K020□	R88G-HPG32A053K0B□ (for both with R88M-K3K030□)	R88G-HPG32A112K0SB□ (for both with R88M-K2K020□)	R88G-HPG32A211K0SB□	R88G-HPG50A332K0SB□ (for both with R88M-K2K020□)	R88G-HPG50A451K0SB□
R88M-K1K520□	R88G-HPG32A053K0B□ (for both with R88M-K3K030□)	R88G-HPG32A112K0SB□ (for both with R88M-K2K020□)	R88G-HPG50A213K0B□ (for both with R88M-K3K030□)	R88G-HPG50A332K0SB□ (for both with R88M-K2K020□)	—
R88M-K2K020□	R88G-HPG32A053K0B□ (for both with R88M-K3K030□)	R88G-HPG32A112K0SB□	R88G-HPG50A213K0B□ (for both with R88M-K3K030□)	R88G-HPG50A332K0SB□	—
R88M-K3K020□	R88G-HPG32A054K0B□ (for both with R88M-K4K030□)	R88G-HPG50A115K0B□ (for both with R88M-K5K030□)	R88G-HPG50A213K0SB□	R88G-HPG65A253K0SB□	—
R88M-K4K020□	R88G-HPG50A055K0SB□ (for both with R88M-K5K020□)	R88G-HPG50A115K0SB□ (for both with R88M-K3K030□)	R88G-HPG65A205K0SB□ (for both with R88M-K3K030□)	R88G-HPG65A255K0SB□ (for both with R88M-K5K020□)	—
R88M-K5K020□	R88G-HPG50A055K0SB□	R88G-HPG50A115K0SB□	R88G-HPG65A205K0SB□	R88G-HPG65A255K0SB□	—

1,000-r/min Servomotors

Servomotor models	1/5	1/11	1/21 (1/20 for flange 65)	1/33 (1/25 for flange 65)
R88M-K90010□	R88G-HPG32A05900TB□	R88G-HPG32A11900TB□	R88G-HPG50A21900TB□	R88G-HPG50A33900TB□
R88M-K2K010□	R88G-HPG32A052K0TB□	R88G-HPG50A112K0TB□	R88G-HPG50A212K0TB□ (for both with R88M-K5K020□)	R88G-HPG65A255K0SB□ (for both with R88M-K5K020□)
R88M-K3K010□	R88G-HPG50A055K0SB□ (for both with R88M-K5K020□)	R88G-HPG50A115K0SB□ (for both with R88M-K5K020□)	R88G-HPG65A205K0SB□ (for both with R88M-K5K020□)	R88G-HPG65A255K0SB□ (for both with R88M-K5K020□)

2-4-4 Reduction Gear Dimensions

3 Arcminutes Max.

- For 3,000-r/min Servomotors (50 to 200 W)

	Model	External view	Dimensions (mm)												
			LM	LR	C1	C2	D1	D2	D3	D4	D5	E	F1	F2	
50 W	1/5 R88G-HPG11B05100B□	1 ²	39.5	42	40	□40	46	46	40	39.5	29	27	2.2	15	
	1/9 R88G-HPG11B09050B□	1 ²	39.5	42	40	□40	46	46	40	39.5	29	27	2.2	15	
	1/21 R88G-HPG14A21100B□	1	64.0	58	60	□60	70	46	56	55.5	40	37	2.5	21	
	1/33 R88G-HPG14A33050B□	1	64.0	58	60	□60	70	46	56	55.5	40	37	2.5	21	
	1/45 R88G-HPG14A45050B□	1	64.0	58	60	□60	70	46	56	55.5	40	37	2.5	21	
100 W	1/5 R88G-HPG11B05100B□	1 ²	39.5	42	40	□40	46	46	40	39.5	29	27	2.2	15	
	1/11 R88G-HPG14A11100B□	1	64.0	58	60	□60	70	46	56	55.5	40	37	2.5	21	
	1/21 R88G-HPG14A21100B□	1	64.0	58	60	□60	70	46	56	55.5	40	37	2.5	21	
	1/33 R88G-HPG20A33100B□	2	66.5	80	90	∅55	105	46	85	84	59	53	7.5	27	
	1/45 R88G-HPG20A45100B□	2	66.5	80	90	∅55	105	46	85	84	59	53	7.5	27	
200 W	1/5 R88G-HPG14A05200B□	1	64.0	58	60	□60	70	70	56	55.5	40	37	2.5	21	
	1/11 R88G-HPG14A11200B□	1	64.0	58	60	□60	70	70	56	55.5	40	37	2.5	21	
	1/21 R88G-HPG20A21200B□	1	71.0	80	90	□90	105	70	85	84	59	53	7.5	27	
	1/33 R88G-HPG20A33200B□	2	71.0	80	90	∅89	105	70	85	84	59	53	7.5	27	
	1/45 R88G-HPG20A45200B□	2	71.0	80	90	∅89	105	70	85	84	59	53	7.5	27	

Note 1 The standard shaft type is a straight shaft.

2 A model with a key and tap is indicated by adding "J" to the end of the model number (the suffix shown in the box). (Example : R88G-HPG11B05100BJ)

3 The diameter of the motor shaft insertion is same as of the corresponding Servomotor shaft.

4 The external dimensions diagrams in this manual provide only the main dimensions. They are not intended to show the detail shapes of the products.

● External view 1

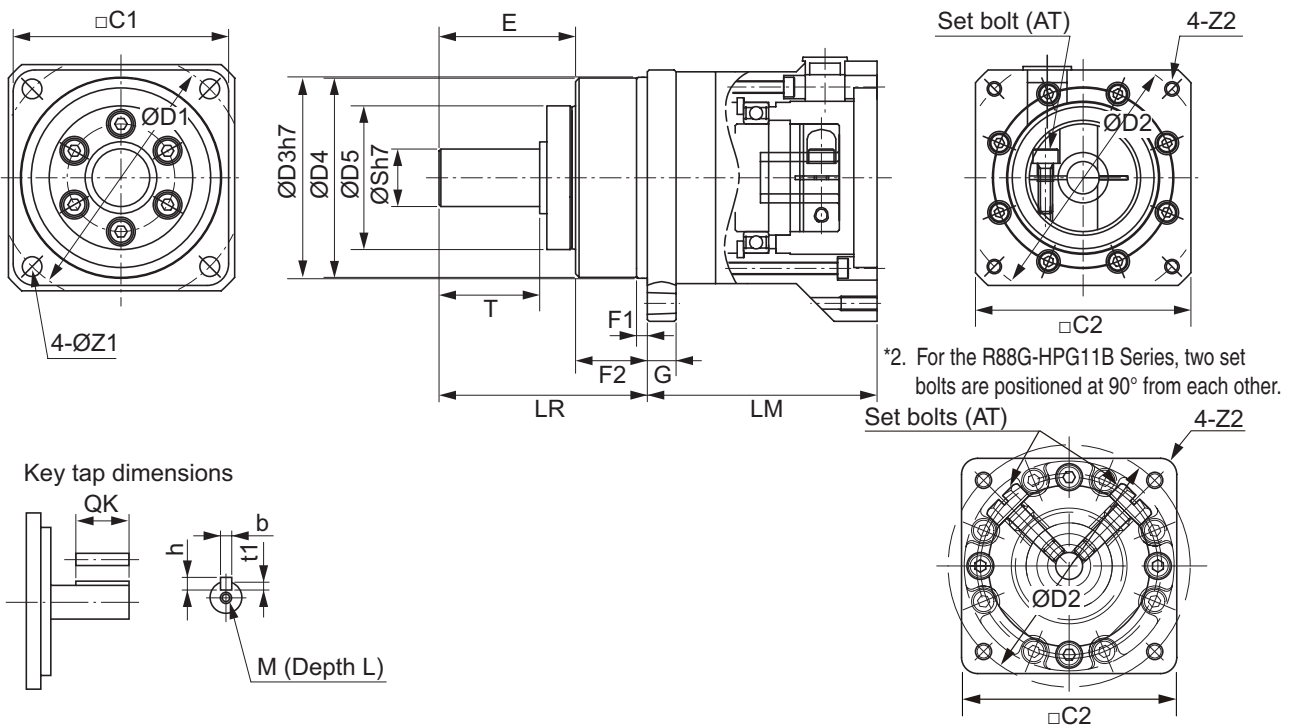

Dimensions (mm)													Model		
G	S	T	Z1	Z2	AT*1	Key				Tap					
						QK	b	h	t1	M	L				
5	8	20	3.4	M4 × 9	M3	15	3	3	1.8	M3	6	R88G-HPG11B05100B□	1/5	50 W	
5	8	20	3.4	M4 × 9	M3	15	3	3	1.8	M3	6	R88G-HPG11B09050B□	1/9		
8	16	28	5.5	M4 × 10	M3	25	5	5	3	M4	8	R88G-HPG14A21100B□	1/21		
8	16	28	5.5	M4 × 10	M3	25	5	5	3	M4	8	R88G-HPG14A33050B□	1/33		
8	16	28	5.5	M4 × 10	M3	25	5	5	3	M4	8	R88G-HPG14A45050B□	1/45		
5	8	20	3.4	M4 × 9	M3	15	3	3	1.8	M3	6	R88G-HPG11B05100B□	1/5		100 W
8	16	28	5.5	M4 × 10	M3	25	5	5	3	M4	8	R88G-HPG14A11100B□	1/11		
8	16	28	5.5	M4 × 10	M3	25	5	5	3	M4	8	R88G-HPG14A21100B□	1/21		
10	25	42	9	M4 × 10	M4	36	8	7	4	M6	12	R88G-HPG20A33100B□	1/33		
10	25	42	9	M4 × 10	M4	36	8	7	4	M6	12	R88G-HPG20A45100B□	1/45		
8	16	28	5.5	M4 × 10	M4	25	5	5	3	M4	8	R88G-HPG14A05200B□	1/5	200 W	
8	16	28	5.5	M4 × 10	M4	25	5	5	3	M4	8	R88G-HPG14A11200B□	1/11		
10	25	42	9	M4 × 10	M4	36	8	7	4	M6	12	R88G-HPG20A21200B□	1/21		
10	25	42	9	M4 × 10	M4	36	8	7	4	M6	12	R88G-HPG20A33200B□	1/33		
10	25	42	9	M4 × 10	M4	36	8	7	4	M6	12	R88G-HPG20A45200B□	1/45		
10	25	42	9	M4 × 10	M4	36	8	7	4	M6	12	R88G-HPG20A45200B□	1/45		

*1 Indicates set bolt.

● External view 2

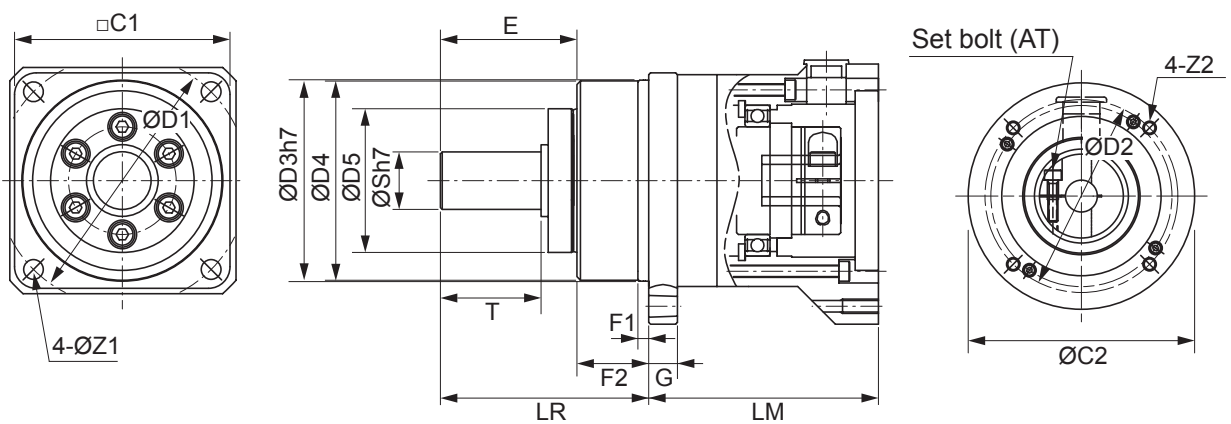

Key tap dimensions

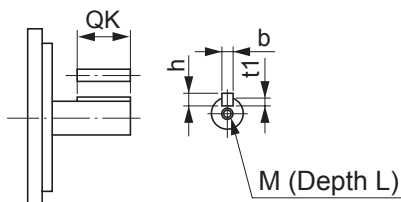

● For 3,000-r/min Servomotors (400 to 750 W)

Model			External view	Dimensions (mm)											
				LM	LR	C1	C2	D1	D2	D3	D4	D5	E	F1	F2
400 W	1/5	R88G-HPG14A05400B□	1	64	58	60	□60	70	70	56	55.5	40	37	2.5	21
	1/11	R88G-HPG20A11400B□	2	71	80	90	∅89	105	70	85	84	59	53	7.5	27
	1/21	R88G-HPG20A21400B□	2	71	80	90	∅89	105	70	85	84	59	53	7.5	27
	1/33	R88G-HPG32A33400B□	2	104	133	120	∅122	135	70	115	114	84	98	12.5	35
	1/45	R88G-HPG32A45400B□	2	104	133	120	∅122	135	70	115	114	84	98	12.5	35
750 W (200 V)	1/5	R88G-HPG20A05750B□	1	78	80	90	□80	105	90	85	84	59	53	7.5	27
	1/11	R88G-HPG20A11750B□	1	78	80	90	□80	105	90	85	84	59	53	7.5	27
	1/21	R88G-HPG32A21750B□	2	104	133	120	∅122	135	90	115	114	84	98	12.5	35
	1/33	R88G-HPG32A33750B□	2	104	133	120	∅122	135	90	115	114	84	98	12.5	35
	1/45	R88G-HPG32A45750B□	2	104	133	120	∅122	135	90	115	114	84	98	12.5	35
750 W (400 V)	1/5	R88G-HPG32A052K0B□	2	110	133	120	∅135	135	115	115	114	84	98	12.5	35
	1/11	R88G-HPG32A112K0B□	2	110	133	120	∅135	135	115	115	114	84	98	12.5	35
	1/21	R88G-HPG32A211K5B□	2	110	133	120	∅135	135	115	115	114	84	98	12.5	35
	1/33	R88G-HPG32A33600SB□	2	110	133	120	∅135	135	115	115	114	84	98	12.5	35
	1/45	R88G-HPG50A451K5B□	2	123	156	170	∅170	190	115	165	163	122	103	12	53

Note The external dimensions diagrams in this manual provide only the main dimensions. They are not intended to show the detail shapes of the products.

● External view 1

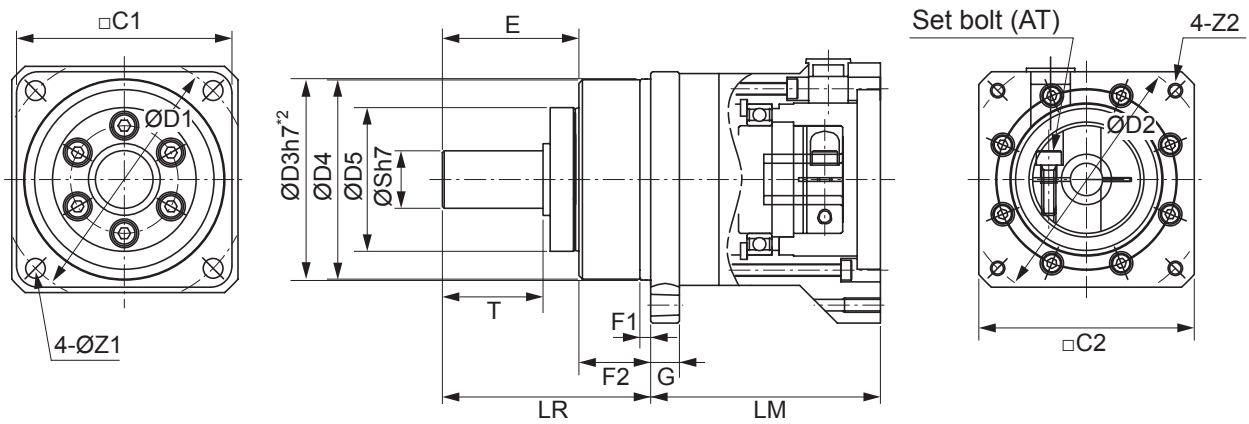

Key tap dimensions

*2 The tolerance is "h8" for R88G-HPG50□ or R88G-HPG65□.

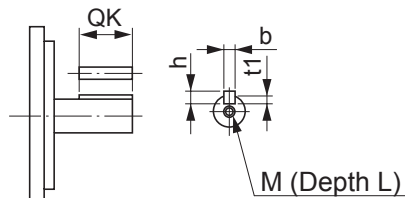

Dimensions (mm)												Model		
G	S	T	Z1	Z2	AT *1	Key				Tap				
						QK	b	h	t1	M	L			
8	16	28	5.5	M4 × 10	M4	25	5	5	3	M4	8	R88G-HPG14A05400B□	1/5	400 W
10	25	42	9	M4 × 10	M4	36	8	7	4	M6	12	R88G-HPG20A11400B□	1/11	
10	25	42	9	M4 × 10	M4	36	8	7	4	M6	12	R88G-HPG20A21400B□	1/21	
13	40	82	11	M4 × 10	M4	70	12	8	5	M10	20	R88G-HPG32A33400B□	1/33	
13	40	82	11	M4 × 10	M4	70	12	8	5	M10	20	R88G-HPG32A45400B□	1/45	
10	25	42	9	M5 × 12	M4	36	8	7	4	M6	12	R88G-HPG20A05750B□	1/5	750 W (200 V)
10	25	42	9	M5 × 12	M4	36	8	7	4	M6	12	R88G-HPG20A11750B□	1/11	
13	40	82	11	M5 × 12	M6	70	12	8	5	M10	20	R88G-HPG32A21750B□	1/21	
13	40	82	11	M5 × 12	M6	70	12	8	5	M10	20	R88G-HPG32A33750B□	1/33	
13	40	82	11	M5 × 12	M6	70	12	8	5	M10	20	R88G-HPG32A45750B□	1/45	
13	40	82	11	M8 × 10	M6	70	12	8	5	M10	20	R88G-HPG32A052K0B□	1/5	750 W (400 V)
13	40	82	11	M8 × 10	M6	70	12	8	5	M10	20	R88G-HPG32A112K0B□	1/11	
13	40	82	11	M8 × 10	M6	70	12	8	5	M10	20	R88G-HPG32A211K5B□	1/21	
13	40	82	11	M8 × 10	M6	70	12	8	5	M10	20	R88G-HPG32A33600SB□	1/33	
16	50	82	14	M8 × 10	M6	70	14	9	5.5	M10	20	R88G-HPG50A451K5B□	1/45	

*1 Indicates set bolt.

● External view 2

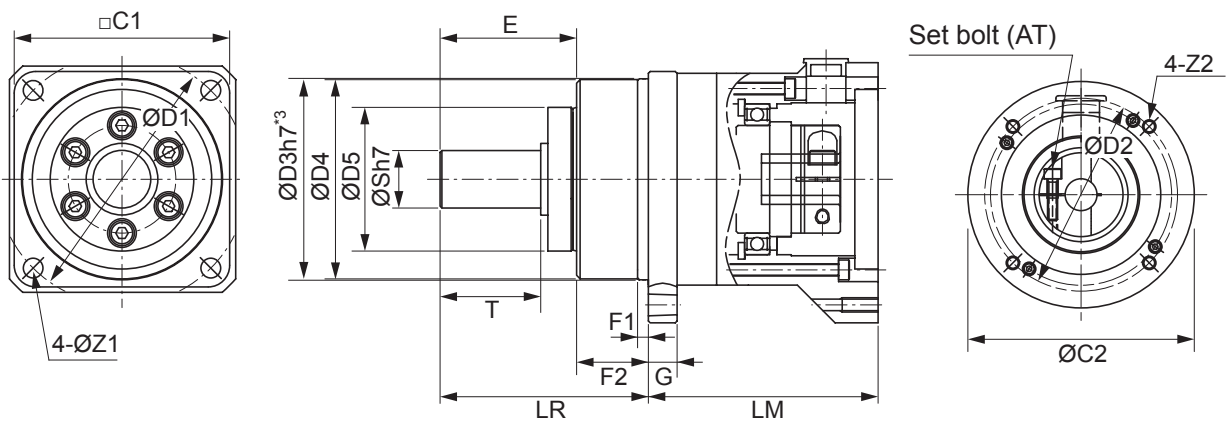

Key tap dimensions

*3 The tolerance is "h8" for R88G-HPG50□ or R88G-HPG65□.

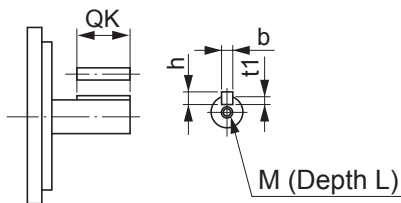

● For 3,000-r/min Servomotors (1 kW to 5 kW)

Model			External view	Dimensions (mm)											
				LM	LR	C1	C2	D1	D2	D3	D4	D5	E	F1	F2
1 kW	1/5	R88G-HPG32A052K0B□	2	110	133	120	∅135	135	115	115	114	84	98	12.5	35
	1/11	R88G-HPG32A112K0B□	2	110	133	120	∅135	135	115	115	114	84	98	12.5	35
	1/21	R88G-HPG32A211K5B□	2	110	133	120	∅135	135	115	115	114	84	98	12.5	35
	1/33	R88G-HPG50A332K0B□	2	123	156	170	∅170	190	115	165	163	122	103	12	53
	1/45	R88G-HPG50A451K5B□	2	123	156	170	∅170	190	115	165	163	122	103	12	53
1.5 kW	1/5	R88G-HPG32A052K0B□	2	110	133	120	∅135	135	115	115	114	84	98	12.5	35
	1/11	R88G-HPG32A112K0B□	2	110	133	120	∅135	135	115	115	114	84	98	12.5	35
	1/21	R88G-HPG32A211K5B□	2	110	133	120	∅135	135	115	115	114	84	98	12.5	35
	1/33	R88G-HPG50A332K0B□	2	123	156	170	∅170	190	115	165	163	122	103	12	53
	1/45	R88G-HPG50A451K5B□	2	123	156	170	∅170	190	115	165	163	122	103	12	53
2 kW	1/5	R88G-HPG32A052K0B□	2	110	133	120	∅135	135	115	115	114	84	98	12.5	35
	1/11	R88G-HPG32A112K0B□	2	110	133	120	∅135	135	115	115	114	84	98	12.5	35
	1/21	R88G-HPG50A212K0B□	2	123	156	170	∅170	190	115	165	163	122	103	12	53
	1/33	R88G-HPG50A332K0B□	2	123	156	170	∅170	190	115	165	163	122	103	12	53
3 kW	1/5	R88G-HPG32A053K0B□	1	107	133	120	□130	135	145	115	114	84	98	12.5	35
	1/11	R88G-HPG50A113K0B□	2	123	156	170	∅170	190	145	165	163	122	103	12	53
	1/21	R88G-HPG50A213K0B□	2	123	156	170	∅170	190	145	165	163	122	103	12	53
4 kW	1/5	R88G-HPG32A054K0B□	1	129	133	120	□130	135	145	115	114	84	98	12.5	35
	1/11	R88G-HPG50A115K0B□	1	149	156	170	□130	190	145	165	163	122	103	12	53
5 kW	1/5	R88G-HPG50A055K0B□	1	149	156	170	□130	190	145	165	163	122	103	12	53
	1/11	R88G-HPG50A115K0B□	1	149	156	170	□130	190	145	165	163	122	103	12	53

- Note 1** The standard shaft type is a straight shaft.
2 A model with a key and tap is indicated by adding "J" to the end of the model number (the suffix shown in the box). (Example : R88G-HPG32A051K0BJ)
3 The diameter of the motor shaft insertion is same as of the corresponding Servomotor shaft.
4 The external dimensions diagrams in this manual provide only the main dimensions. They are not intended to show the detail shapes of the products.

● External view

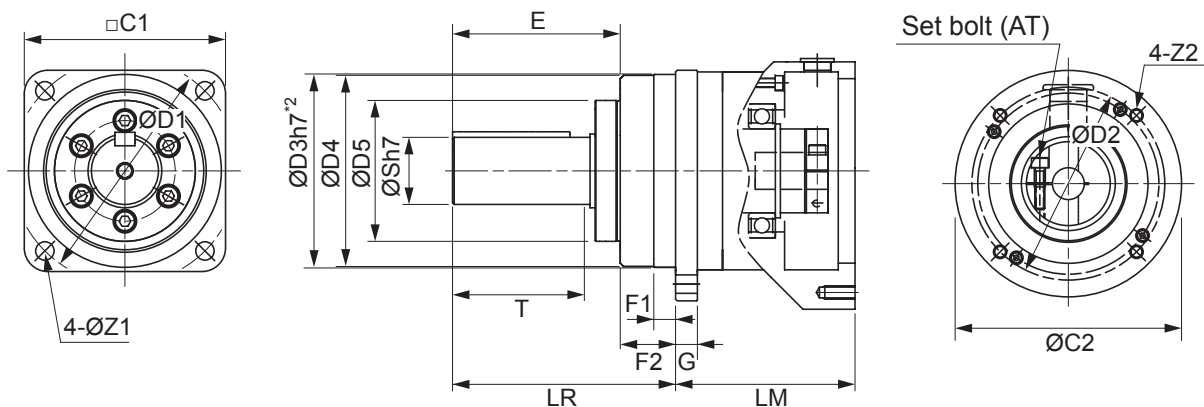

Key tap dimensions

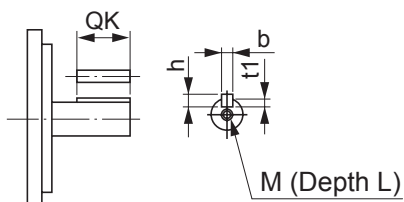

*2 The tolerance is "h8" for R88G-HPG50□.

Dimensions (mm)												Model		
G	S	T	Z1	Z2	AT*1	Key				Tap				
						QK	b	h	t1	M	L			
13	40	82	11	M8 × 10	M6	70	12	8	5	M10	20	R88G-HPG32A052K0B□	1/5	1 kW
13	40	82	11	M8 × 10	M6	70	12	8	5	M10	20	R88G-HPG32A112K0B□	1/11	
13	40	82	11	M8 × 10	M6	70	12	8	5	M10	20	R88G-HPG32A211K5B□	1/21	
16	50	82	14	M8 × 10	M6	70	14	9	5.5	M10	20	R88G-HPG50A332K0B□	1/33	
16	50	82	14	M8 × 10	M6	70	14	9	5.5	M10	20	R88G-HPG50A451K5B□	1/45	1.5 kW
13	40	82	11	M8 × 10	M6	70	12	8	5	M10	20	R88G-HPG32A052K0B□	1/5	
13	40	82	11	M8 × 10	M6	70	12	8	5	M10	20	R88G-HPG32A112K0B□	1/11	
13	40	82	11	M8 × 10	M6	70	12	8	5	M10	20	R88G-HPG32A211K5B□	1/21	
16	50	82	14	M8 × 10	M6	70	14	9	5.5	M10	20	R88G-HPG50A332K0B□	1/33	2 kW
16	50	82	14	M8 × 10	M6	70	14	9	5.5	M10	20	R88G-HPG50A451K5B□	1/45	
13	40	82	11	M8 × 10	M6	70	12	8	5	M10	20	R88G-HPG32A052K0B□	1/5	
13	40	82	11	M8 × 10	M6	70	12	8	5	M10	20	R88G-HPG32A112K0B□	1/11	
16	50	82	14	M8 × 10	M6	70	14	9	5.5	M10	20	R88G-HPG50A212K0B□	1/21	3 kW
16	50	82	14	M8 × 10	M6	70	14	9	5.5	M10	20	R88G-HPG50A332K0B□	1/33	
13	40	82	11	M8 × 18	M6	70	12	8	5	M10	20	R88G-HPG32A053K0B□	1/5	
16	50	82	14	M8 × 16	M6	70	14	9	5.5	M10	20	R88G-HPG50A113K0B□	1/11	
16	50	82	14	M8 × 16	M6	70	14	9	5.5	M10	20	R88G-HPG50A213K0B□	1/21	4 kW
13	40	82	11	M8 × 25	M6	70	12	8	5	M10	20	R88G-HPG32A054K0B□	1/5	
16	50	82	14	M8 × 25	M6	70	14	9	5.5	M10	20	R88G-HPG50A115K0B□	1/11	
16	50	82	14	M8 × 25	M6	70	14	9	5.5	M10	20	R88G-HPG50A055K0B□	1/5	
16	50	82	14	M8 × 25	M6	70	14	9	5.5	M10	20	R88G-HPG50A115K0B□	1/11	5 kW

*1 Indicates set bolt.

● External view 2

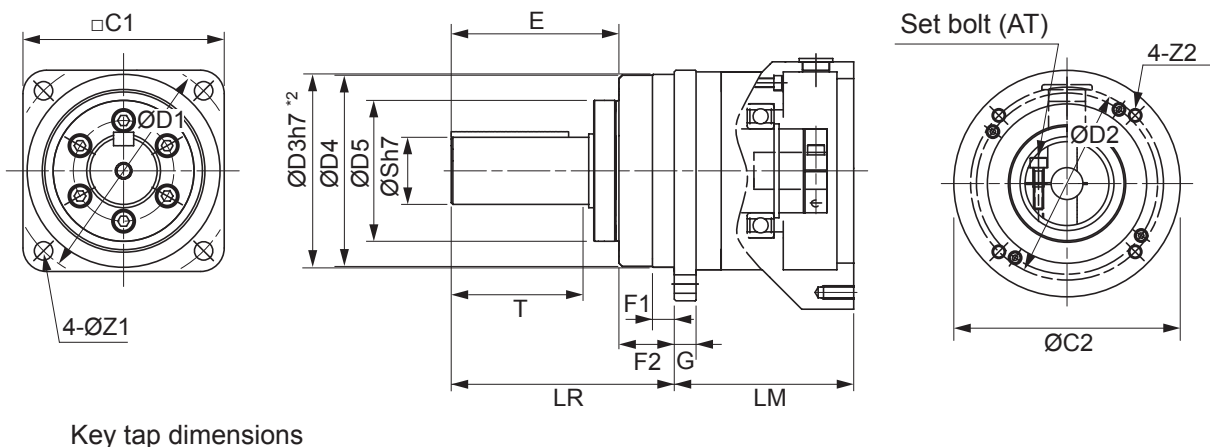

*2 The tolerance is "h8" for R88G-HPG50□ or R88G-HPG65□.

● For 2,000-r/min Servomotors (400 W to 1 kW)

Model			External view	Dimensions (mm)											
				LM	LR	C1	C2	D1	D2	D3	D4	D5	E	F1	F2
400 W (400 V)	1/5	R88G-HPG32A052K0B□	2	110	133	120	∅135	135	115	115	114	84	98	12.5	35
	1/11	R88G-HPG32A112K0B□	2	110	133	120	∅135	135	115	115	114	84	98	12.5	35
	1/21	R88G-HPG32A211K5B□	2	110	133	120	∅135	135	115	115	114	84	98	12.5	35
	1/33	R88G-HPG32A33600SB□	2	110	133	120	∅135	135	115	115	114	84	98	12.5	35
	1/45	R88G-HPG32A45400SB□	2	110	133	120	∅135	135	115	115	114	84	98	12.5	35
600 W (400 V)	1/5	R88G-HPG32A052K0B□	2	110	133	120	∅135	135	115	115	114	84	98	12.5	35
	1/11	R88G-HPG32A112K0B□	2	110	133	120	∅135	135	115	115	114	84	98	12.5	35
	1/21	R88G-HPG32A211K5B□	2	110	133	120	∅135	135	115	115	114	84	98	12.5	35
	1/33	R88G-HPG32A33600SB□	2	110	133	120	∅135	135	115	115	114	84	98	12.5	35
	1/45	R88G-HPG50A451K5B□	2	123	156	170	∅170	190	115	165	163	122	103	12	53
1 kW	1/5	R88G-HPG32A053K0B□	1	107	133	120	□130	135	145	115	114	84	98	12.5	35
	1/11	R88G-HPG32A112K0SB□	1	107	133	120	□130	135	145	115	114	84	98	12.5	35
	1/21	R88G-HPG32A211K0SB□	1	107	133	120	□130	135	145	115	114	84	98	12.5	35
	1/33	R88G-HPG50A332K0SB□	2	123	156	170	∅170	190	145	165	163	122	103	12	53
	1/45	R88G-HPG50A451K0SB□	2	123	156	170	∅170	190	145	165	163	122	103	12	53

Note 1 The standard shaft type is a straight shaft.

2 A model with a key and tap is indicated by adding “J” to the end of the model number (the suffix shown in the box).
(Example : R88G-HPG32A053K0BJ)

3 The diameter of the motor shaft insertion is same as of the corresponding Servomotor shaft.

4 The external dimensions diagrams in this manual provide only the main dimensions. They are not intended to show the detail shapes of the products.

● External view 1

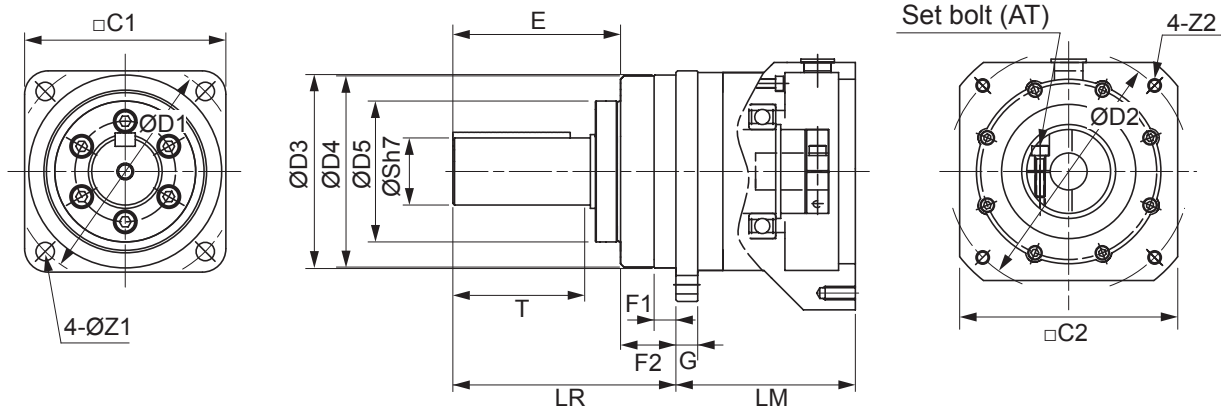

Key tap dimensions

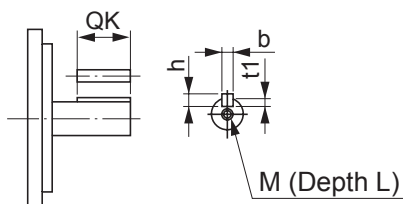

Dimensions (mm)													Model		
G	S	T	Z1	Z2	AT*1	Key				Tap					
						QK	b	h	t1	M	L				
13	40	82	11	M8 × 10	M6	70	12	8	5	M10	20	R88G-HPG32A052K0B□	1/5	400 W (400 V)	
13	40	82	11	M8 × 10	M6	70	12	8	5	M10	20	R88G-HPG32A112K0B□	1/11		
13	40	82	11	M8 × 10	M6	70	12	8	5	M10	20	R88G-HPG32A211K5B□	1/21		
13	40	82	11	M8 × 10	M6	70	12	8	5	M10	20	R88G-HPG32A33600SB□	1/33		
13	40	82	11	M8 × 10	M6	70	12	8	5	M10	20	R88G-HPG32A45400SB□	1/45		
13	40	82	11	M8 × 10	M6	70	12	8	5	M10	20	R88G-HPG32A052K0B□	1/5	600 W (400 V)	
13	40	82	11	M8 × 10	M6	70	12	8	5	M10	20	R88G-HPG32A112K0B□	1/11		
13	40	82	11	M8 × 10	M6	70	12	8	5	M10	20	R88G-HPG32A211K5B□	1/21		
13	40	82	11	M8 × 10	M6	70	12	8	5	M10	20	R88G-HPG32A33600SB□	1/33		
16	50	82	14	M8 × 10	M6	70	14	9	5.5	M10	20	R88G-HPG50A451K5B□	1/45	1 kW	
13	40	82	11	M8 × 18	M6	70	12	8	5	M10	20	R88G-HPG32A053K0B□	1/5		
13	40	82	11	M8 × 18	M6	70	12	8	5	M10	20	R88G-HPG32A112K0SB□	1/11		
13	40	82	11	M8 × 18	M6	70	12	8	5	M10	20	R88G-HPG32A211K0SB□	1/21		
16	50	82	14	M8 × 16	M6	70	14	9	5.5	M10	20	R88G-HPG50A332K0SB□	1/33		
16	50	82	14	M8 × 16	M6	70	14	9	5.5	M10	20	R88G-HPG50A451K0SB□	1/45		

*1 Indicates set bolt.

● External view 2

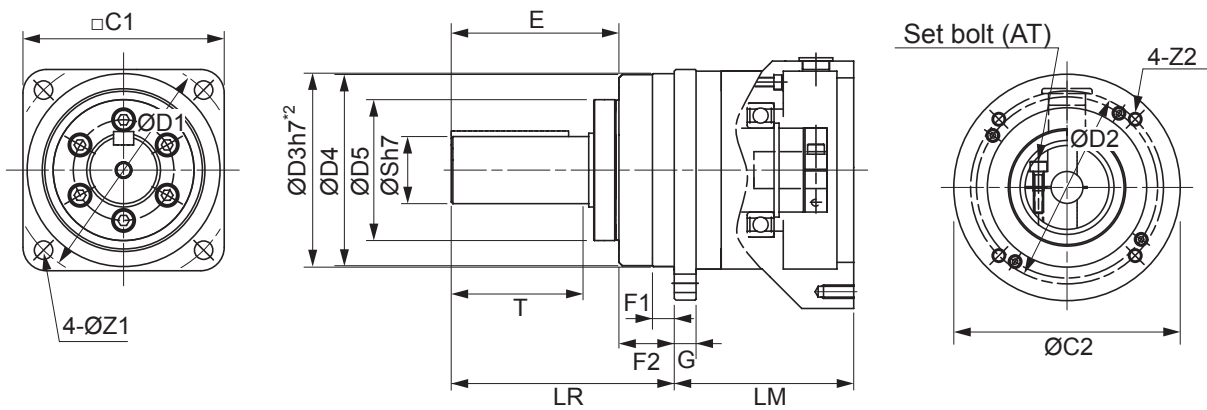

Key tap dimensions

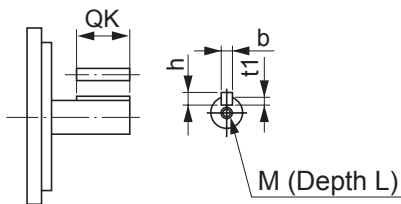

*2 The tolerance is "h8" for R88G-HPG50□ or R88G-HPG65□.

● For 2,000-r/min Servomotors (1.5 kW to 5 kW)

Model			External view	Dimensions (mm)											
				LM	LR	C1	C2	D1	D2	D3	D4	D5	E	F1	F2
1.5 kW	1/5	R88G-HPG32A053K0B□	1	107	133	120	□130	135	145	115	114	84	98	12.5	35
	1/11	R88G-HPG32A112K0SB□	1	107	133	120	□130	135	145	115	114	84	98	12.5	35
	1/21	R88G-HPG50A213K0B□	2	123	156	170	∅170	190	145	165	163	122	103	12	53
	1/33	R88G-HPG50A332K0SB□	2	123	156	170	∅170	190	145	165	163	122	103	12	53
2 kW	1/5	R88G-HPG32A053K0B□	1	107	133	120	□130	135	145	115	114	84	98	12.5	35
	1/11	R88G-HPG32A112K0SB□	1	107	133	120	□130	135	145	115	114	84	98	12.5	35
	1/21	R88G-HPG50A213K0B□	2	123	156	170	∅170	190	145	165	163	122	103	12	53
	1/33	R88G-HPG50A332K0SB□	2	123	156	170	∅170	190	145	165	163	122	103	12	53
3 kW	1/5	R88G-HPG32A054K0B□	1	129	133	120	□130	135	145	115	114	84	98	12.5	35
	1/11	R88G-HPG50A115K0B□	1	149	156	170	□130	190	145	165	163	122	103	12	53
	1/21	R88G-HPG50A213K0SB□	1	149	156	170	□130	190	145	165	163	122	103	12	53
	1/25	R88G-HPG65A253K0SB□	1	231	222	230	□130	260	145	220	214	168	165	12	57
4 kW	1/5	R88G-HPG50A055K0SB□	1	149	156	170	□180	190	200	165	163	122	103	12	53
	1/11	R88G-HPG50A115K0SB□	1	149	156	170	□180	190	200	165	163	122	103	12	53
	1/20	R88G-HPG65A205K0SB□	1	231	222	230	□180	260	200	220	214	168	165	12	57
	1/25	R88G-HPG65A255K0SB□	1	231	222	230	□180	260	200	220	214	168	165	12	57
5 kW	1/5	R88G-HPG50A055K0SB□	1	149	156	170	□180	190	200	165	163	122	103	12	53
	1/11	R88G-HPG50A115K0SB□	1	149	156	170	□180	190	200	165	163	122	103	12	53
	1/20	R88G-HPG65A205K0SB□	1	231	222	230	□180	260	200	220	214	168	165	12	57
	1/25	R88G-HPG65A255K0SB□	1	231	222	230	□180	260	200	220	214	168	165	12	57

Note The external dimensions diagrams in this manual provide only the main dimensions. They are not intended to show the detail shapes of the products.

● External view 1

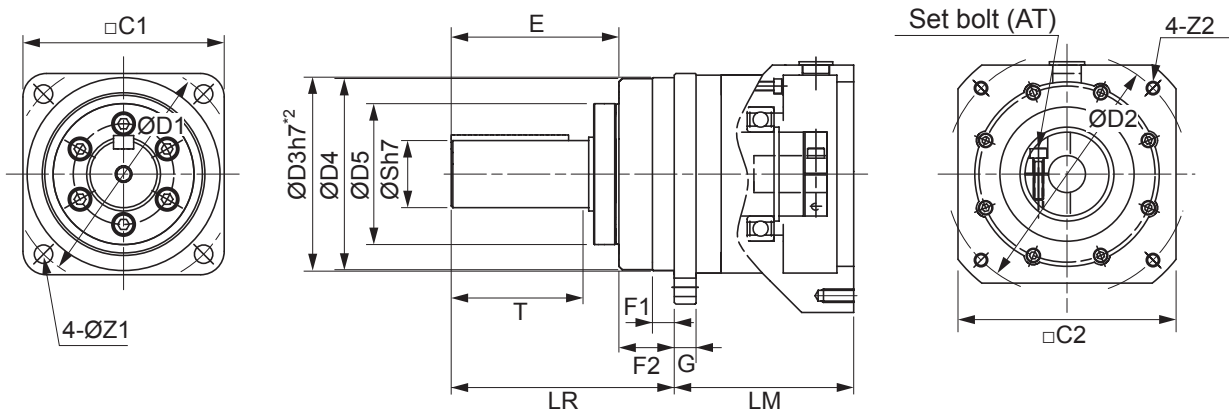

Key tap dimensions

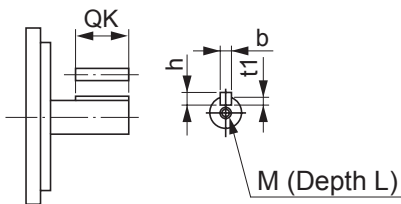

*2 The tolerance is "h8" for R88G-HPG50□ or R88G-HPG65□.

Dimensions (mm)													Model		
G	S	T	Z1	Z2	AT*1	Key				Tap					
						QK	b	h	t1	M	L				
13	40	82	11	M8 × 18	M6	70	12	8	5	M10	20	R88G-HPG32A053K0B□	1/5	1.5 kW	
13	40	82	11	M8 × 18	M6	70	12	8	5	M10	20	R88G-HPG32A112K0SB□	1/11		
16	50	82	14	M8 × 16	M6	70	14	9	5.5	M10	20	R88G-HPG50A213K0B□	1/21		
16	50	82	14	M8 × 16	M6	70	14	9	5.5	M10	20	R88G-HPG50A332K0SB□	1/33		
13	40	82	11	M8 × 18	M6	70	12	8	5	M10	20	R88G-HPG32A053K0B□	1/5	2 kW	
13	40	82	11	M8 × 18	M6	70	12	8	5	M10	20	R88G-HPG32A112K0SB□	1/11		
16	50	82	14	M8 × 16	M6	70	14	9	5.5	M10	20	R88G-HPG50A213K0B□	1/21		
16	50	82	14	M8 × 16	M6	70	14	9	5.5	M10	20	R88G-HPG50A332K0SB□	1/33		
13	40	82	11	M8 × 25	M6	70	12	8	5	M10	20	R88G-HPG32A054K0B□	1/5	3 kW	
16	50	82	14	M8 × 25	M6	70	14	9	5.5	M10	20	R88G-HPG50A115K0B□	1/11		
16	50	82	14	M8 × 25	M6	70	14	9	5.5	M10	20	R88G-HPG50A213K0SB□	1/21		
25	80	130	18	M8 × 25	M8	110	22	14	9	M16	35	R88G-HPG65A253K0SB□	1/25		
16	50	82	14	M12 × 25	M6	70	14	9	5.5	M10	20	R88G-HPG50A055K0SB□	1/5	4 kW	
16	50	82	14	M12 × 25	M6	70	14	9	5.5	M10	20	R88G-HPG50A115K0SB□	1/11		
25	80	130	18	M12 × 25	M8	110	22	14	9	M16	35	R88G-HPG65A205K0SB□	1/20		
25	80	130	18	M12 × 25	M8	110	22	14	9	M16	35	R88G-HPG65A255K0SB□	1/25		
16	50	82	14	M12 × 25	M6	70	14	9	5.5	M10	20	R88G-HPG50A055K0SB□	1/5	5 kW	
16	50	82	14	M12 × 25	M6	70	14	9	5.5	M10	20	R88G-HPG50A115K0SB□	1/11		
25	80	130	18	M12 × 25	M8	110	22	14	9	M16	35	R88G-HPG65A205K0SB□	1/20		
25	80	130	18	M12 × 25	M8	110	22	14	9	M16	35	R88G-HPG65A255K0SB□	1/25		

*1 Indicates set bolt.

● External view 2

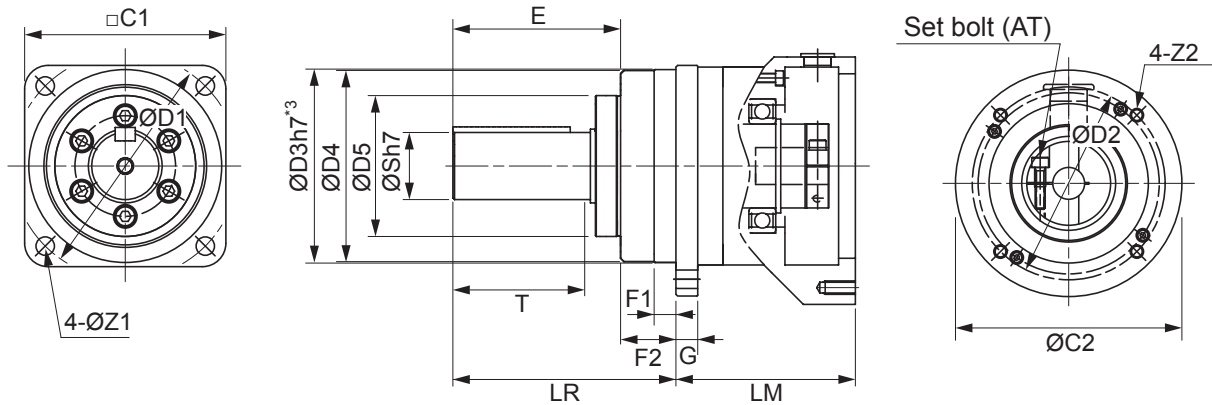

Key tap dimensions

*3 The tolerance is "h8" for R88G-HPG50□ or R88G-HPG65□.

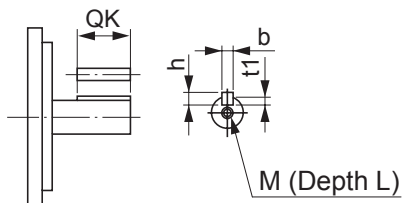

● For 1,000-r/min Servomotors (900 W to 3 kW)

Model			External view	Dimensions (mm)											
				LM	LR	C1	C2	D1	D2	D3	D4	D5	E	F1	F2
900 W	1/5	R88G-HPG32A05900TB□	1	129	133	120	□130	135	145	115	114	84	98	12.5	35
	1/11	R88G-HPG32A11900TB□	1	129	133	120	□130	135	145	115	114	84	98	12.5	35
	1/21	R88G-HPG50A21900TB□	1	149	156	170	□130	190	145	165	163	122	103	12	53
	1/33	R88G-HPG50A33900TB□	1	149	156	170	□130	190	145	165	163	122	103	12	53
2 kW	1/5	R88G-HPG32A052K0TB□	1	129	133	120	□180	135	200	115	114	84	98	12.5	35
	1/11	R88G-HPG50A112K0TB□	1	149	156	170	□180	190	200	165	163	122	103	12	53
	1/21	R88G-HPG50A212K0TB□	1	149	156	170	□180	190	200	165	163	122	103	12	53
	1/25	R88G-HPG65A255K0SB□	1	231	222	230	□180	260	200	220	214	168	165	12	57
3 kW	1/5	R88G-HPG50A055K0SB□	1	149	156	170	□180	190	200	165	163	122	103	12	53
	1/11	R88G-HPG50A115K0SB□	1	149	156	170	□180	190	200	165	163	122	103	12	53
	1/20	R88G-HPG65A205K0SB□	1	231	222	230	□180	260	200	220	214	168	165	12	57
	1/25	R88G-HPG65A255K0SB□	1	231	222	230	□180	260	200	220	214	168	165	12	57

Note 1 The standard shaft type is a straight shaft.

2 A model with a key and tap is indicated by adding “J” to the end of the model number (the suffix shown in the box).
(Example : R88G-HPG32A05900TBJ)

3 The diameter of the motor shaft insertion is same as of the corresponding Servomotor shaft.

4 The external dimensions diagrams in this manual provide only the main dimensions. They are not intended to show the detail shapes of the products.

● External view 1

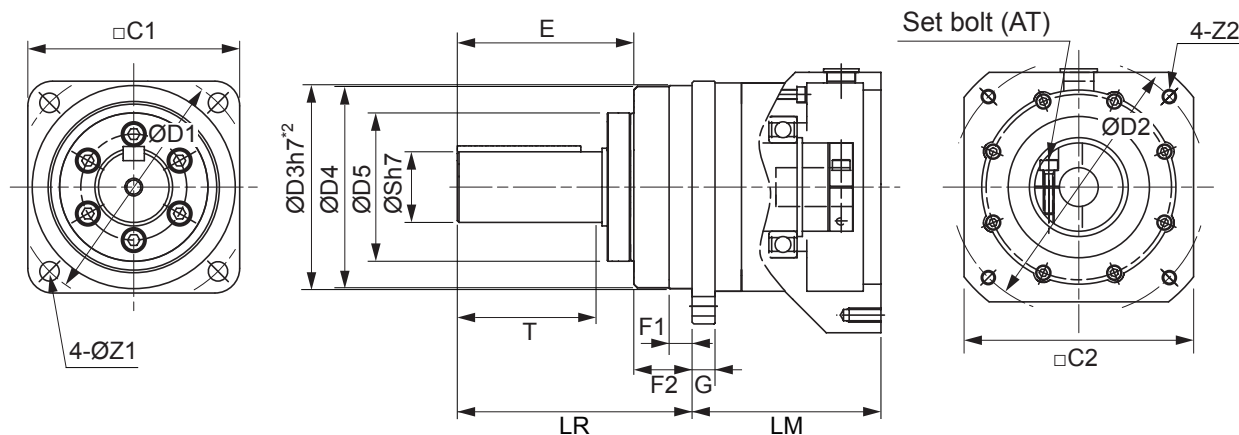

Key tap dimensions

*2 The tolerance is “h8” for R88G-HPG50□ or R88G-HPG65□.

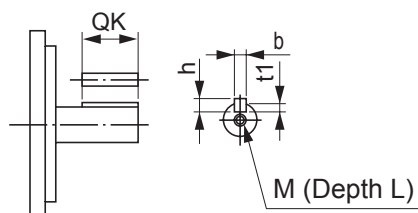

Dimensions (mm)													Model		
G	S	T	Z1	Z2	AT*1	Key				Tap					
						QK	b	h	t1	M	L				
13	40	82	11	M8 × 25	M6	70	12	8	5	M10	20	R88G-HPG32A05900TB□	1/5	900 W	
13	40	82	11	M8 × 25	M6	70	12	8	5	M10	20	R88G-HPG32A11900TB□	1/11		
16	50	82	14	M8 × 25	M6	70	14	9	5.5	M10	20	R88G-HPG50A21900TB□	1/21		
16	50	82	14	M8 × 25	M6	70	14	9	5.5	M10	20	R88G-HPG50A33900TB□	1/33		
13	40	82	11	M12 × 25	M6	70	12	8	5	M10	20	R88G-HPG32A052K0TB□	1/5	2 kW	
16	50	82	14	M12 × 25	M6	70	14	9	5.5	M10	20	R88G-HPG50A112K0TB□	1/11		
16	50	82	14	M12 × 25	M6	70	14	9	5.5	M10	20	R88G-HPG50A212K0TB□	1/21		
25	80	130	18	M12 × 25	M8	110	22	14	9	M16	35	R88G-HPG65A255K0SB□	1/25	3 kW	
16	50	82	14	M12 × 25	M6	70	14	9	5.5	M10	20	R88G-HPG50A055K0SB□	1/5		
16	50	82	14	M12 × 25	M6	70	14	9	5.5	M10	20	R88G-HPG50A115K0SB□	1/11		
25	80	130	18	M12 × 25	M8	110	22	14	9	M16	35	R88G-HPG65A205K0SB□	1/20		
25	80	130	18	M12 × 25	M8	110	22	14	9	M16	35	R88G-HPG65A255K0SB□	1/25		

*1 Indicates set bolt.

15 Arcminutes Max.

● For 3,000-r/min Servomotors

Model			Dimensions (mm)										
			LM	LR	C1	C2	D1	D2	D3	D4	E3	F	G
50 W	1/5	R88G-VRSF05B100CJ	67.5	32	40	52	46	60	50	45	10	3	6
	1/9	R88G-VRSF09B100CJ	67.5	32	40	52	46	60	50	45	10	3	6
	1/15	R88G-VRSF15B100CJ	78.0	32	40	52	46	60	50	45	10	3	6
	1/25	R88G-VRSF25B100CJ	78.0	32	40	52	46	60	50	45	10	3	6
100 W	1/5	R88G-VRSF05B100CJ	67.5	32	40	52	46	60	50	45	10	3	6
	1/9	R88G-VRSF09B100CJ	67.5	32	40	52	46	60	50	45	10	3	6
	1/15	R88G-VRSF15B100CJ	78.0	32	40	52	46	60	50	45	10	3	6
	1/25	R88G-VRSF25B100CJ	78.0	32	40	52	46	60	50	45	10	3	6
200 W	1/5	R88G-VRSF05B200CJ	72.5	32	60	52	70	60	50	45	10	3	10
	1/9	R88G-VRSF09C200CJ	89.5	50	60	78	70	90	70	62	17	3	8
	1/15	R88G-VRSF15C200CJ	100.0	50	60	78	70	90	70	62	17	3	8
	1/25	R88G-VRSF25C200CJ	100.0	50	60	78	70	90	70	62	17	3	8
400 W	1/5	R88G-VRSF05C400CJ	89.5	50	60	78	70	90	70	62	17	3	8
	1/9	R88G-VRSF09C400CJ	89.5	50	60	78	70	90	70	62	17	3	8
	1/15	R88G-VRSF15C400CJ	100.0	50	60	78	70	90	70	62	17	3	8
	1/25	R88G-VRSF25C400CJ	100.0	50	60	78	70	90	70	62	17	3	8
750 W	1/5	R88G-VRSF05C750CJ	93.5	50	80	78	90	90	70	62	17	3	10
	1/9	R88G-VRSF09D750CJ	97.5	61	80	98	90	115	90	75	18	5	10
	1/15	R88G-VRSF15D750CJ	110.0	61	80	98	90	115	90	75	18	5	10
	1/25	R88G-VRSF25D750CJ	110.0	61	80	98	90	115	90	75	18	5	10

- Note 1** The standard shaft type is a shaft with key.
Note 2 The diameter of the motor shaft insertion is same as of the corresponding Servomotor shaft.

● External view

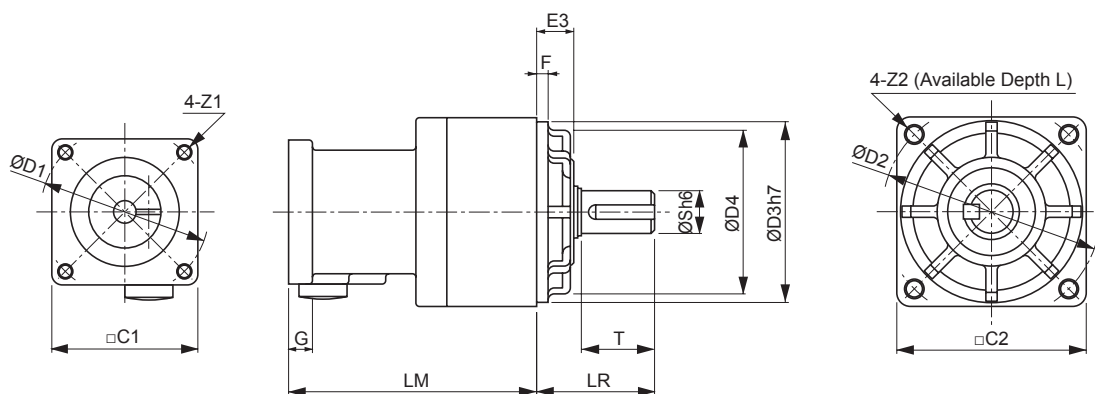

Dimensions (mm)											Model				
S	T	Z1	Z2	AT*1	L	Key									
						QK	b	h	t1						
12	20	M4	M5	M3	12	16	4	4	2.5	R88G-VRSF05B100CJ	1/5	50 W			
12	20	M4	M5	M3	12	16	4	4	2.5	R88G-VRSF09B100CJ	1/9				
12	20	M4	M5	M3	12	16	4	4	2.5	R88G-VRSF15B100CJ	1/15				
12	20	M4	M5	M3	12	16	4	4	2.5	R88G-VRSF25B100CJ	1/25				
12	20	M4	M5	M3	12	16	4	4	2.5	R88G-VRSF05B100CJ	1/5	100 W			
12	20	M4	M5	M3	12	16	4	4	2.5	R88G-VRSF09B100CJ	1/9				
12	20	M4	M5	M3	12	16	4	4	2.5	R88G-VRSF15B100CJ	1/15				
12	20	M4	M5	M3	12	16	4	4	2.5	R88G-VRSF25B100CJ	1/25				
12	20	M4	M5	M4	12	16	4	4	2.5	R88G-VRSF05B200CJ	1/5	200 W			
19	30	M4	M6	M4	20	22	6	6	3.5	R88G-VRSF09C200CJ	1/9				
19	30	M4	M6	M4	20	22	6	6	3.5	R88G-VRSF15C200CJ	1/15				
19	30	M4	M6	M4	20	22	6	6	3.5	R88G-VRSF25C200CJ	1/25				
19	30	M4	M6	M4	20	22	6	6	3.5	R88G-VRSF05C400CJ	1/5	400 W			
19	30	M4	M6	M4	20	22	6	6	3.5	R88G-VRSF09C400CJ	1/9				
19	30	M4	M6	M4	20	22	6	6	3.5	R88G-VRSF15C400CJ	1/15				
19	30	M4	M6	M4	20	22	6	6	3.5	R88G-VRSF25C400CJ	1/25				
19	30	M5	M6	M4	20	22	6	6	3.5	R88G-VRSF05C750CJ	1/5	750 W			
24	40	M5	M8	M4	20	30	8	7	4	R88G-VRSF09D750CJ	1/9				
24	40	M5	M8	M4	20	30	8	7	4	R88G-VRSF15D750CJ	1/15				
24	40	M5	M8	M4	20	30	8	7	4	R88G-VRSF25D750CJ	1/25				

*1 Indicates set bolt.

● External view

Set bolt (AT)

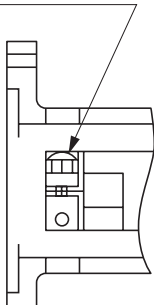

Key dimensions

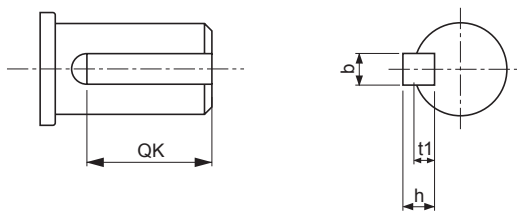

2-4-5 External Regeneration Resistor Dimensions

External Regeneration Resistor

- R88A-RR08050S/-RR080100S

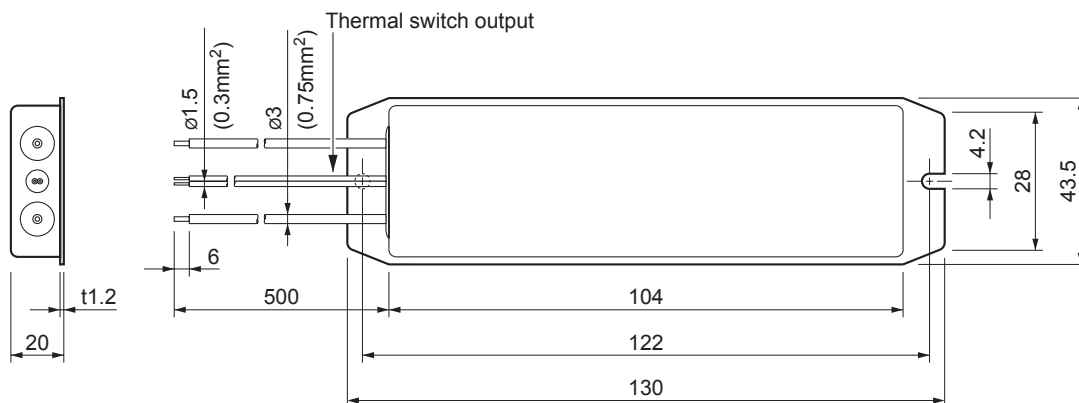

- R88A-RR22047S1

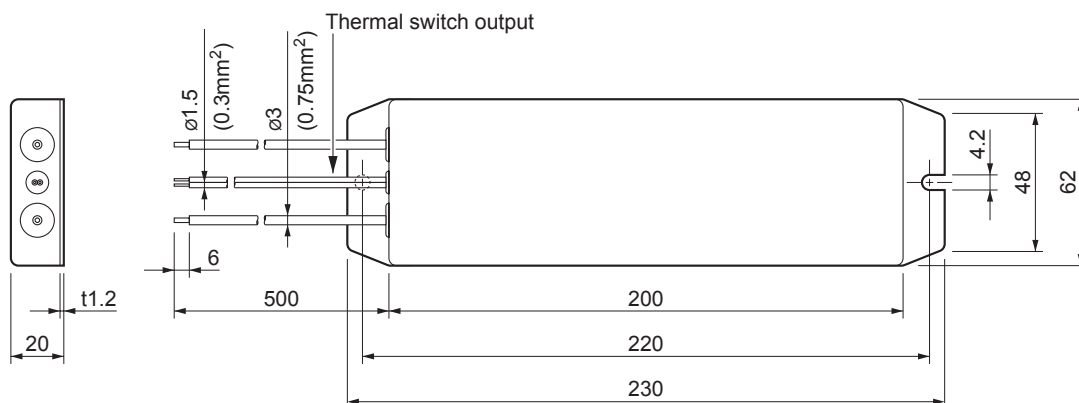

- R88A-RR50020S

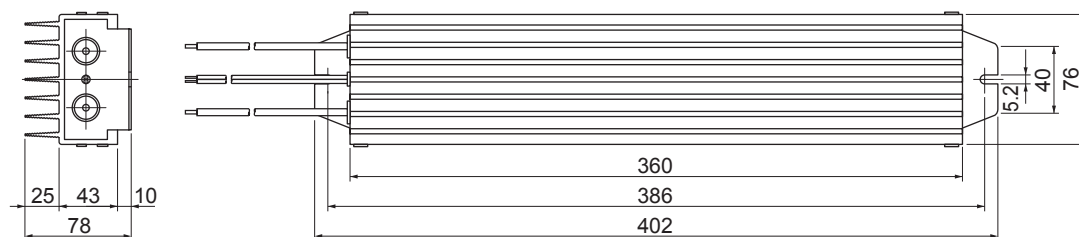

2-4-6 Reactor Dimensions

3G3AX-DL2002

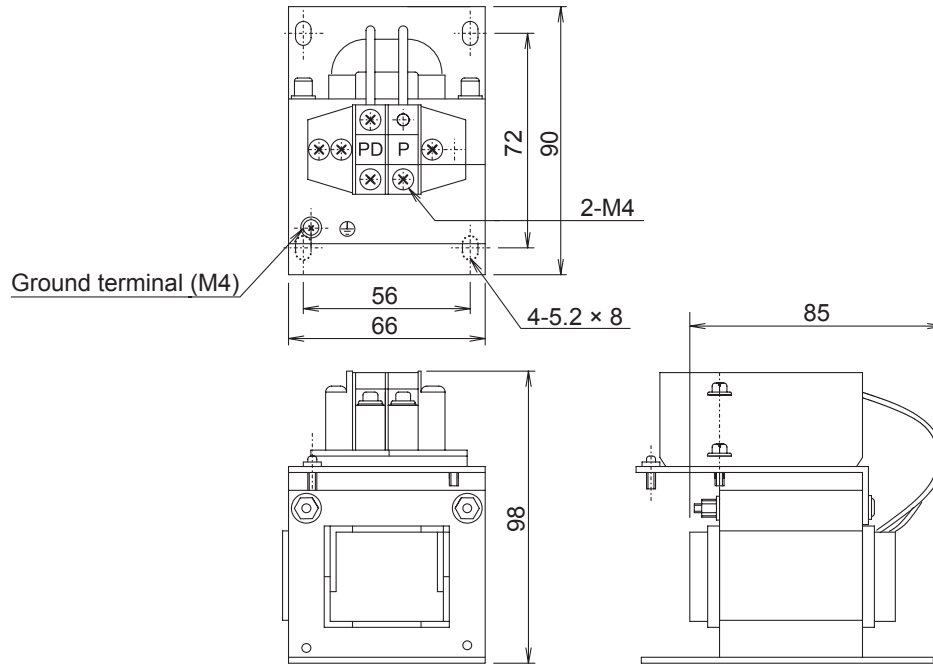

3G3AX-DL2004

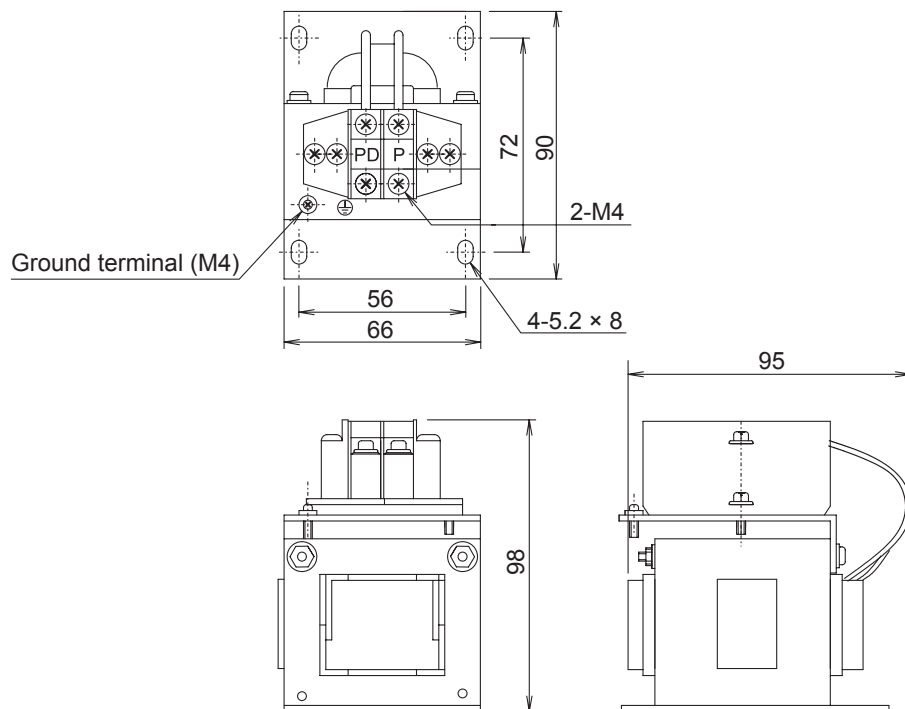

3G3AX-DL2007

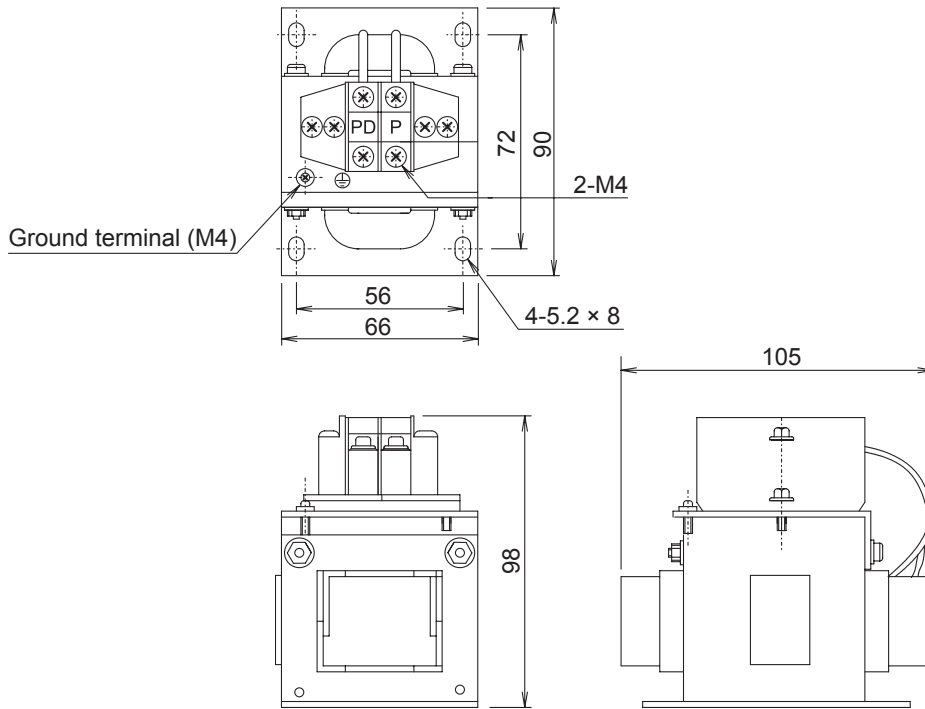

3G3AX-DL2015

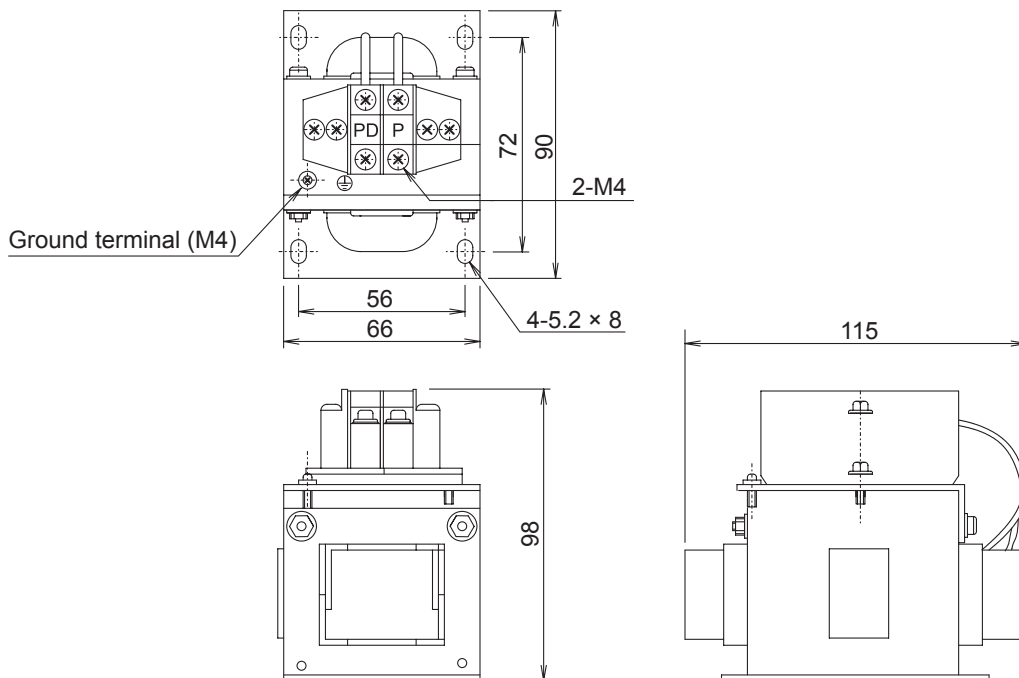

3G3AX-DL2022

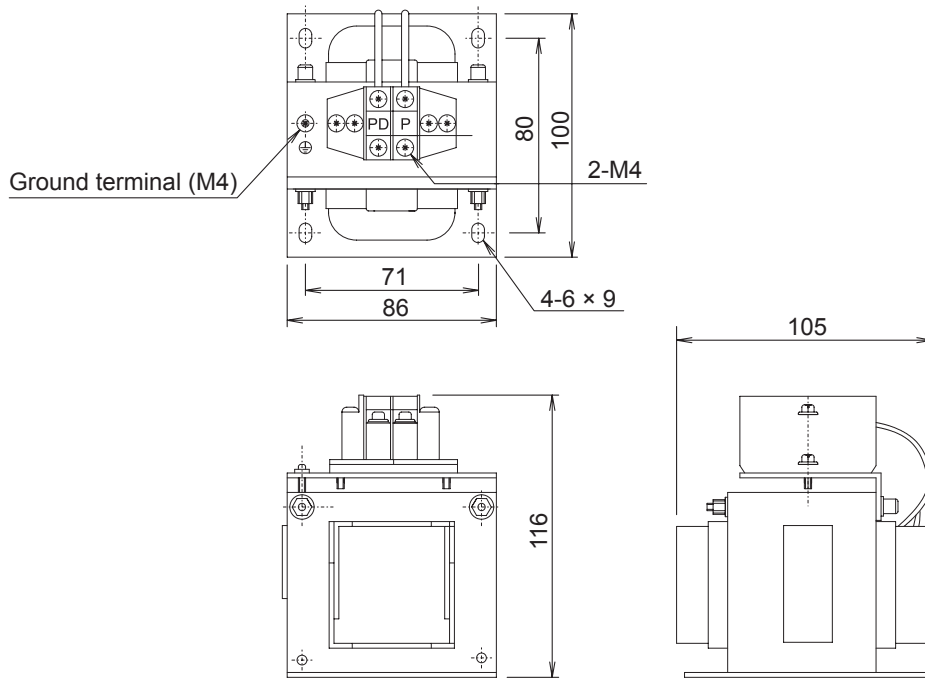

3G3AX-AL2025/-AL2055/-AL4025/-AL4055

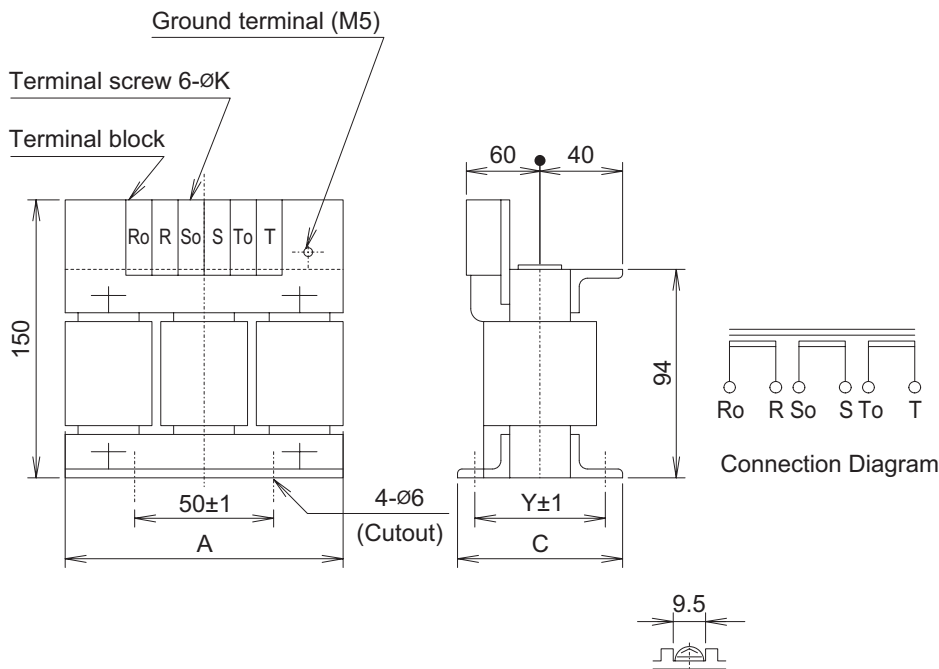

Model	Dimensions (mm)			
	A	C	Y	K
3G3AX-AL2025	120	82	67	4
3G3AX-AL2055	120	98	75	4
3G3AX-AL4025	130	82	67	4
3G3AX-AL4055	130	98	75	5

3G3AX-AL2110/-AL2220/-AL4110/-AL4220

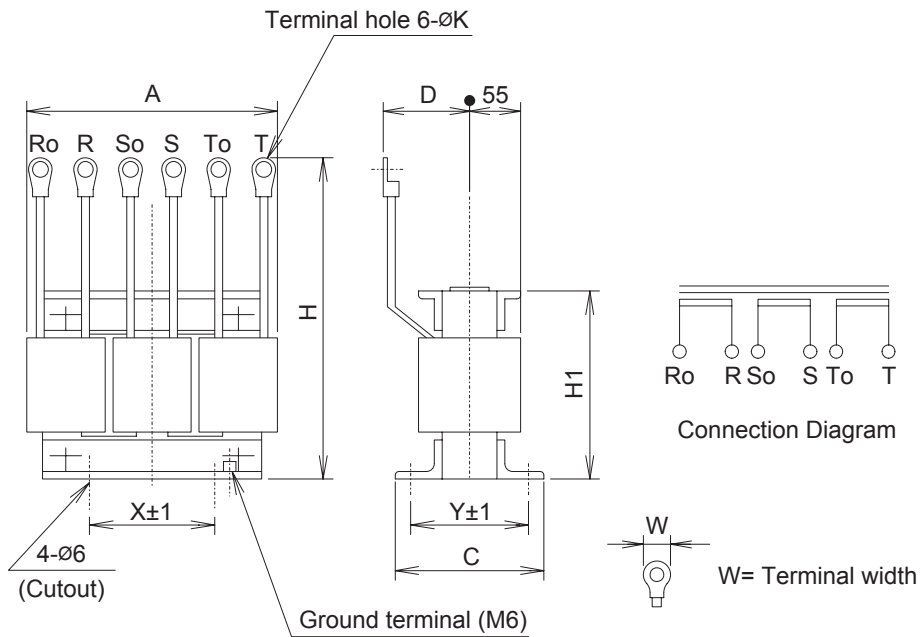

Model	Dimensions (mm)								
	A	C	D	H	H1	X	Y	K	W
3G3AX-AL2110	150	103	70	170	108	60	80	5.3	12
3G3AX-AL2220	180	113	75	190	140	90	90	8.4	16.5
3G3AX-AL4110	150	116	75	170	106	60	98	5.0	12.5
3G3AX-AL4220	180	103	75	190	140	100	80	5.3	12

2-4-7 Mounting Bracket (L-brackets for Rack Mounting) Dimensions

R88A-TK01K

Mounting bracket for top side

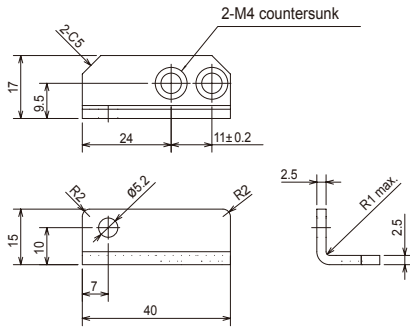

Mounting bracket for bottom side

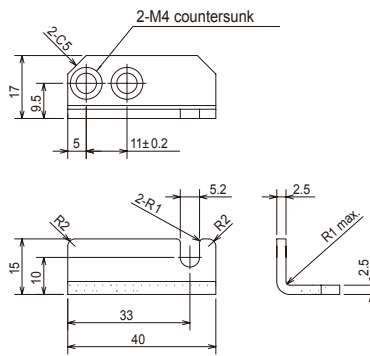

R88A-TK02K

Mounting bracket for top side

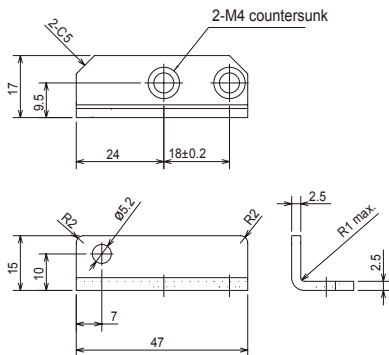

Mounting bracket for bottom side

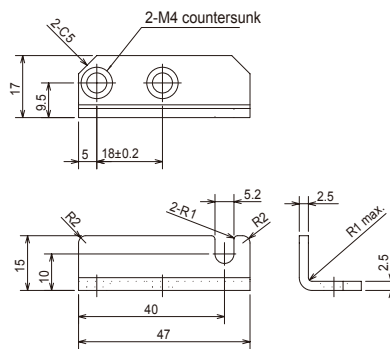

R88A-TK03K

Mounting bracket for top side

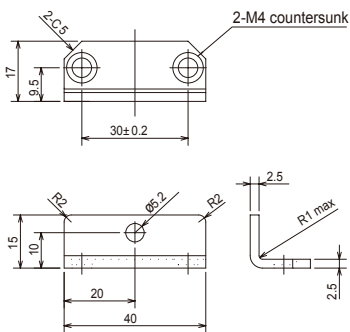

Mounting bracket for bottom side

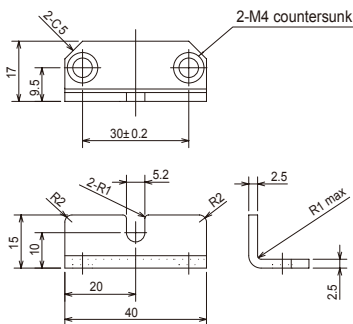

R88A-TK04K

Mounting bracket for top side

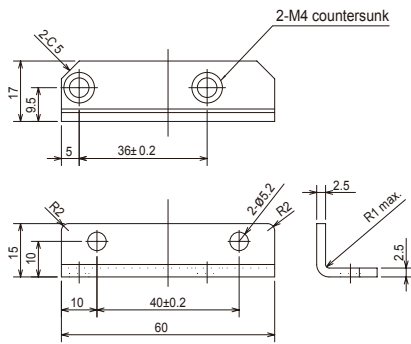

Mounting bracket for bottom side

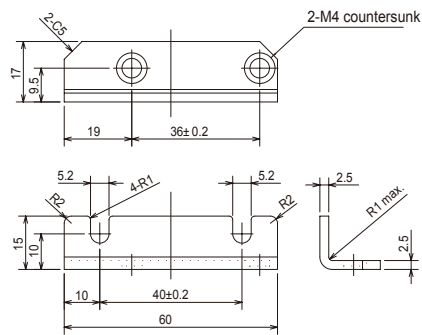

3

Specifications

This chapter provides the general specifications, characteristics, connector specifications, and I/O circuits of the Servo Drives as well as the general specifications, characteristics, encoder specifications of the Servomotors and other peripheral devices.

3-1	Servo Drive Specifications	3-2
3-1-1	General Specifications	3-2
3-1-2	Characteristics	3-3
3-1-3	EtherCAT Communications Specifications	3-7
3-1-4	Main Circuit and Motor Connections	3-8
3-1-5	EtherCAT Communications Connector Specifications (RJ45)	3-17
3-1-6	Control I/O Connector Specifications (CN1)	3-18
3-1-7	Control Input Circuits	3-21
3-1-8	Control Input Details	3-21
3-1-9	Control Output Circuits	3-23
3-1-10	Control Output Details	3-24
3-1-11	Encoder Connector Specifications (CN2)	3-28
3-1-12	External Encoder Connector Specifications (CN4)	3-28
3-1-13	Analog Monitor Connector Specifications (CN5)	3-31
3-1-14	USB Connector Specifications (CN7)	3-32
3-1-15	Safety Connector Specifications (CN8)	3-33
3-2	Overload Characteristics (Electronic Thermal Function)	3-35
3-2-1	Overload Characteristics Graphs	3-35
3-3	Servomotor Specifications	3-36
3-3-1	General Specifications	3-36
3-3-2	Characteristics	3-37
3-3-3	Encoder Specifications	3-59
3-4	Reduction Gear Specifications	3-60
3-4-1	Models and Specifications	3-60
3-5	Cable and Connector Specifications	3-67
3-5-1	Bend Radius of Robot Cable	3-67
3-5-2	Encoder Cable Specifications	3-69
3-5-3	Absolute Encoder Battery Cable Specifications	3-74
3-5-4	Motor Power Cable Specifications	3-75
3-5-5	Connector Specifications	3-91
3-5-6	EtherCAT Communications Cable Specifications	3-94
3-5-7	Analog Monitor Cable Specifications	3-97
3-5-8	Control Cable Specifications	3-99
3-6	External Regeneration Resistor Specifications	3-104
3-6-1	External Regeneration Resistor Specifications	3-104
3-7	Reactor Specifications	3-106
3-7-1	Specifications	3-106

3-1 Servo Drive Specifications

Select a Servo Drive that matches the Servomotor to be used. Refer to *2-3-3 Servo Drive and Servomotor Combination Tables* on page 2-14.

3-1-1 General Specifications

Item		Specifications	
Ambient operating temperature and operating humidity		0 to 55°C, 90% max. (with no condensation)	
Storage ambient temperature and humidity		-20 to 65°C, 90% max. (with no condensation)	
Operating and storage atmosphere		No corrosive gases	
Vibration resistance		10 to 60 Hz and at an acceleration of 5.88 m/s ² or less (Not to be run continuously at a resonance point)	
Insulation resistance		Between power supply terminals/power terminals and FG terminal: 0.5 MΩ min. (at 500 VDC)	
Dielectric strength		Between power supply/power line terminals and FG terminal: 1,500 VAC for 1 min at 50/60 Hz	
Protective structure		Built into panel	
International standard	EC Directives	EMC Directive	EN 55011, EN 61000-6-2, IEC 61800-3
		Low Voltage Directive	EN 61800-5-1
		Machinery Directive	EN954-1 (Category 3), EN ISO 13849-1: 2008 (Category 3) (PLc,d), ISO 13849-1: 2006 (Category 3) (PLc,d), EN61508 (SIL2), EN62061 (SIL2), EN61800-5-2 (STO), IEC61326-3-1 (SIL2)
	UL standards		UL 508C
	CSA standards		CSA22.2 No. 14
	Korean Radio Regulations (KC)		Compliant

- Note 1** The above items reflect individual evaluation testing. The results may differ under compound conditions.
- 2** Never perform dielectric strength or other megameter tests on the Servo Drive. Failure to follow this guideline may result in damaging the internal elements.
- 3** Some Servo Drive parts will require maintenance. For details, refer to *12-5 Periodic Maintenance* on page 12-36.

3-1-2 Characteristics

100-VAC Input Models

Item			R88D-KNA5L-ECT	R88D-KN01L-ECT	R88D-KN02L-ECT	R88D-KN04L-ECT
Continuous output current (rms)			1.2 A	1.7 A	2.5 A	4.6 A
Input power supply	Main circuit	Power supply capacity	0.4 KVA	0.4 KVA	0.5 KVA	0.9 KVA
		Power supply voltage	Single-phase 100 to 120 VAC (85 to 132 V) 50/60 Hz			
		Rated current	1.7 A	2.6 A	4.3 A	7.6 A
		Heat value* ¹	11 W	16.6 W	21 W	25 W
	Control circuit	Power supply voltage	Single-phase 100 to 120 VAC (85 to 132 V) 50/60 Hz			
		Heat value* ¹	4 W	4 W	4 W	4 W
Weight			Approx. 0.8 kg	Approx. 0.8 kg	Approx. 1.0 kg	Approx. 1.6 kg
Maximum applicable motor capacity			50 W	100 W	200 W	400 W
Applicable Servomotor	3,000 r/min	INC	K05030H	K10030L	K20030L	K40030L
		ABS	K05030T	K10030S	K20030S	K40030S
	2,000 r/min	ABS	–	–	–	–
	1,000 r/min	ABS	–	–	–	–
Performance	Speed control range		1:5000			
	Speed variation (load characteristic)		0.01% max. from 0% to 100% (percentage of rated speed)			
	Speed variation (voltage characteristic)		0% at rated voltage $\pm 10\%$ (percentage of rated speed)			
	Temperature variation (temperature characteristic)		$\pm 0.01\%$ max. (percentage of rated speed) from 0 to 50°C			
	Torque control repeatability		$\pm 1\%$			

*1 The heat value is given for rated operation.

200-VAC Input Models

Item			R88D-KN01H-ECT	R88D-KN02H-ECT	R88D-KN04H-ECT	R88D-KN08H-ECT	R88D-KN10H-ECT	R88D-KN15H-ECT
Continuous output current (rms)			1.2 A	1.6 A	2.6 A	4.1 A	5.9 A	9.4 A
Input power supply	Main circuit	Power supply capacity	0.5 KVA	0.5 KVA	0.9 KVA	1.3 KVA	1.8 KVA	2.3KVA
		Power supply voltage	Single-phase or 3-phase 200 to 240 VAC (170 to 264 V) 50/60 Hz					
		Rated current	1.6/0.9 A *1	2.4/1.3 A*1	4.1/2.4 A*1	6.6/3.6 A*1	9.1/5.2 A*1	14.2/8.1 A*1
		Heat value *2	14.3/13.7 W *1	23/19 W *1	33/24 W *1	30/35.5 W *1	57/49 W *1	104/93 W *1
Control circuit	Power supply voltage	Single-phase 200 to 240 VAC (170 to 264 V) 50/60 Hz						
	Heat value *2	4 W	4 W	4 W	4 W	7 W	7 W	
Weight			Approx. 0.8 kg	Approx. 0.8 kg	Approx. 1.0 kg	Approx. 1.6 kg	Approx. 1.8 kg	Approx. 1.8 kg
Maximum applicable motor capacity			100 W	200 W	400 W	750 W	1 kW	1.5 kW
Applicable Servomotor	3,000 r/min	INC	K05030H K10030H	K20030H	K40030H	K75030H	–	K1K030H K1K530H
		ABS	K05030T K10030T	K20030T	K40030T	K75030T	–	K1K030T K1K530T
	2,000 r/min	INC	–	–	–	–	K1K020H	K1K520H
		ABS	–	–	–	–	K1K020T	K1K520T
	1,000 r/min	INC	–	–	–	–	–	K90010H
		ABS	–	–	–	–	–	K90010T
Performance	Speed control range		1:5000					
	Speed variation (load characteristic)		0.01% max. from 0% to 100% (percentage of rated speed)					
	Speed variation (voltage characteristic)		0% at rated voltage $\pm 10\%$ (percentage of rated speed)					
	Temperature variation (temperature characteristic)		$\pm 0.01\%$ max. (percentage of rated speed) from 0 to 50°C					
	Torque control repeatability		$\pm 1\%$					

*1 The first value is for single-phase input power and the second value is for 3-phase input power.

*2 The heat value is given for rated operation.

Item			R88D-KN20H-ECT	R88D-KN30H-ECT	R88D-KN50H-ECT	R88D-KN75H-ECT	R88D-KN150H-ECT	
Continuous output current (rms)			13.4 A	18.7 A	33.0 A	44.0 A	66.1 A	
Input power supply	Main circuit	Power supply capacity	3.3 KVA	4.5 KVA	7.5 KVA	11.0 KVA	22.0 KVA	
		Power supply voltage	3-phase 200 to 230 VAC (170 to 253 V) 50/60 Hz ^{*2}					
		Rated current	11.8 A	15.1 A	21.6 A	32.0 A	58.0 A	
		Heat value ^{*1}	139 W	108 W	328 W	381 W	720 W	
	Control circuit	Power supply voltage	Single-phase 200 to 230 VAC (170 to 253 V) 50/60 Hz ^{*2}					
		Heat value ^{*1}	10 W	13 W	13 W	15 W	17 W	
Weight			Approx. 2.7 kg	Approx. 4.8 kg	Approx. 4.8 kg	Approx. 13.5 kg	Approx. 21.0 kg	
Maximum applicable motor capacity			2 kW	3 kW	5 kW	7.5 kW	15 kW	
Applicable Servomotor	3,000-r/min	INC	K2K030H	K3K030H	K4K030H K5K030H	–	–	
		ABS	K2K030T	K3K030T	K4K030T K5K030T	–	–	
	2,000-r/min or 1,500-r/min	INC	K2K020H	K3K020H	K4K020H K5K020H	–	–	
		ABS	K2K020T	K3K020T	K4K020T K5K020T	K7K515T	K11K015T K15K015T	
	1,000-r/min	INC	–	K2K010H	K3K010H	–	–	
		ABS	–	K2K010T	K3K010T K4K510T	K6K010T	–	
	Performance	Speed control range		1:5000				
		Speed variation (load characteristic)		0.01% max. from 0% to 100% (percentage of rated speed)				
Speed variation (voltage characteristic)		0% at rated voltage ±10% (percentage of rated speed)						
Temperature variation (temperature characteristic)		±0.01% max. (percentage of rated speed) from 0 to 50°C						
Torque control repeatability		±2%						

*1 The heat value is given for rated operation.

*2 R88D-KN75H-ECT and R88D-KN150H-ECT support DC power input in addition to AC power input. DC power supplies with a voltage rating of 280 to 325 VDC (238 to 357 V) can be connected.

400-VAC Input Models

Item			R88D-KN06F-ECT	R88D-KN10F-ECT	R88D-KN15F-ECT	R88D-KN20F-ECT	R88D-KN30F-ECT	R88D-KN50F-ECT	R88D-KN75F-ECT	R88D-KN150F-ECT		
Continuous output current (rms)			1.5 A	2.9 A	4.7 A	6.7 A	9.4 A	16.5 A	22.0 A	33.1 A		
Input power supply	Main circuit	Power supply capacity	1.2 KVA	1.8 KVA	2.3 KVA	3.8 KVA	4.5 KVA	6.0 KVA	11.0 KVA	22.0 KVA		
		Power supply voltage	3-phase 380 to 480 VAC (323 to 528 V) 50/60 Hz									
		Rated current	2.1 A	2.8 A	3.9 A	5.9 A	7.6 A	12.1 A	16.0 A	29.0 A		
		Heat value ^{*1}	32.2 W	48 W	49 W	65 W	108 W	200 W	300 W	590 W		
Control circuit	Power supply voltage	24 VDC (20.4 to 27.6 V)										
		Heat value ^{*1}	7 W	7 W	7 W	10 W	13 W	13 W	15 W	22 W		
Weight			Approx. 1.9 kg	Approx. 1.9 kg	Approx. 1.9 kg	Approx. 2.7 kg	Approx. 4.7 kg	Approx. 4.7 kg	Approx. 13.5 kg	Approx. 21.0 kg		
Maximum applicable motor capacity			600 W	1 kW	1.5 kW	2 kW	3 kW	5 kW	7.5 kW	15 kW		
Applicable Servomotor	3,000-r/min	INC	–	K75030F	K1K030F K1K530F	K2K030F	K3K030F	K4K030F K5K030F	–	–		
		ABS	–	K75030C	K1K030C K1K530C	K2K030C	K3K030C	K4K030C K5K030C	–	–		
	2,000-r/min or 1,500-r/min	INC	K40020F K60020F	K1K020F	K1K520F	K2K020F	K3K020F	K4K020F K5K020F	–	–		
		ABS	K40020C K60020C	K1K020C	K1K520C	K2K020C	K3K020C	K4K020C K5K020C	K7K515C	K11K015C K15K015C		
	1,000-r/min	INC	–	–	K90010F	–	K2K010F	K3K010F	–	–		
		ABS	–	–	K90010C	–	K2K010C	K3K010C K4K510C	K6K010C	–		
	Performance	Speed control range		1:5000								
		Speed variation (load characteristic)		0.01% max. from 0% to 100% (percentage of rated speed)								
Speed variation (voltage characteristic)		0% at rated voltage ±10% (percentage of rated speed)										
Temperature variation (temperature characteristic)		±0.01% max. (percentage of rated speed) from 0 to 50°C										
Torque control repeatability		±1%				±2%						

*1 The heat value is given for rated operation.

3-1-3 EtherCAT Communications Specifications

Item	Specification
Communications standard	IEC 61158 Type 12, IEC 61800-7 CiA 402 Drive Profile
Physical layer	100BASE-TX (IEEE802.3)
Connectors	RJ45 × 2 (shielded) ECAT IN: EtherCAT input ECAT OUT: EtherCAT output
Communications media	Ethernet Category 5 (100BASE-TX) or higher (twisted-pair cable with double, aluminum tape and braided shielding) is recommended.
Communications distance	Distance between nodes: 100 m max.
Process data	Fixed PDO mapping
Mailbox (CoE)	Emergency messages, SDO requests, SDO responses, and SDO information
Distributed clock (DC)	Synchronization in DC mode. DC cycle: 250 μs, 500 μs, 1 ms, 2 ms, 4 ms
Indicators	L/A IN (Link/Activity IN) × 1 L/A OUT (Link/Activity OUT) × 1 RUN × 1 ERR × 1
CiA402 Drive Profile	<ul style="list-style-type: none"> • Cyclic synchronous position mode • Cyclic synchronous velocity mode • Cyclic synchronous torque mode • Profile potion mode • Homing mode • Touch probe function (Latch function) • Torque limit function

3-1-4 Main Circuit and Motor Connections

When wiring the main circuit, use proper wire sizes, grounding systems, and noise resistance.

R88D-KNA5L-ECT/-KN01L-ECT/-KN02L-ECT/-KN04L-ECT/ -KN01H-ECT/-KN02H-ECT/-KN04H-ECT/-KN08H-ECT/ -KN10H-ECT/-KN15H-ECT

● Main Circuit Connector Specifications (CNA)

Symbol	Name	Function
L1	Main circuit power supply input	R88D-KN□L-ECT
L2		50 to 400 W: Single-phase 100 to 120 VAC (85 to 132 V) 50/60 Hz
L3		R88D-KN□H-ECT 100 W to 1.5 kW: Single-phase: 200 to 240 VAC (170 to 264 V) 50/60 Hz 100 W to 1.5 kW: 3-phase: 200 to 240 VAC (170 to 264 V) 50/60 Hz Note: Single-phase should connect to L1 and L3.
L1C	Control circuit power supply input	R88D-KN□L-ECT: Single-phase 100 to 120 VAC (85 to 132 V) 50/60 Hz
L2C		R88D-KN□H-ECT : Single-phase 200 to 240 VAC (170 to 264 V) 50/60 Hz

● Motor Connector Specifications (CNB)

Symbol	Name	Function
B1	External Regeneration Resistor connection terminals	50 to 400 W: Normally, do not short B1 and B2. Doing so may result in malfunctioning. If there is high regenerative energy, connect an External Regeneration Resistor between B1 and B2. 750 W to 1.5 kW: Normally B2 and B3 are shorted. Do not short B1 and B2. Doing so may result in malfunctioning. If there is high regenerative energy, remove the short-circuit bar between B2 and B3 and connect an External Regeneration Resistor between B1 and B2.
B3		
B2		
U	Motor connection terminals	Phase U
V		Phase V
W		Phase W
		These are the output terminals to the Servomotor. Be sure to wire them correctly.

R88D-KN20H-ECT

● Main Circuit Connector Specifications (CNA)

Symbol	Name	Function
L1	Main circuit power supply input	R88D-KN□H-ECT (2 kW) : 3-phase: 200 to 230 VAC (170 to 253 VAC) 50/60 Hz
L2		
L3		
L1C	Control circuit power supply input	R88D-KN□H-ECT: Single-phase 200 to 230 VAC (170 to 253 VAC) 50/60 Hz
L2C		

● Motor Connector Specifications (CNB)

Symbol	Name	Function	
U	Motor connection terminals	Phase U	These are the output terminals to the Servomotor. Be sure to wire them correctly.
V		Phase V	
W		Phase W	

● External Regeneration Resistor Connector Specifications (CNC)

Symbol	Name	Function
B1	External Regeneration Resistor connection terminals	Normally B2 and B3 are shorted. Do not short B1 and B2. Doing so may result in malfunctioning. If there is high regenerative energy, remove the short bar between B2 and B3 and connect an External Regeneration Resistor between B1 and B2.
B3		
B2		
NC	Do not connect.	



Precautions for Correct Use

- Tighten the ground screws to the torque of 0.7 to 0.8 N·m (M4) or 1.4 to 1.6 N·m (M5).
- Do not connect any External Regeneration Resistors between B1 and NC.

R88D-KN30H-ECT/R88D-KN50H-ECT

● Main Circuit Terminal Block Specifications

Symbol	Name	Function	
L1	Main circuit power supply input	R88D-KN□H-ECT (3 to 5 kW): 3-phase 200 to 230 VAC (170 to 253 VAC) 50/60 Hz	
L2			
L3			
L1C	Control circuit power supply input	R88D-KN□H-ECT : Single-phase 200 to 230 VAC (170 to 253 VAC) 50/60 Hz	
L2C			
B1	External Regeneration Resistor connection terminals	Normally B2 and B3 are shorted. Do not short B1 and B2. Doing so may result in malfunctioning. If there is high regenerative energy, remove the short-circuit bar between B2 and B3 and connect an External Regeneration Resistor between B1 and B2.	
B3			
B2			
NC	Do not connect.		
U	Motor connection terminals	Phase U	These are the output terminals to the Servomotor. Be sure to wire them correctly.
V		Phase V	
W		Phase W	



Precautions for Correct Use

- Tighten the terminal block screws to the torque of 0.75 N·m (M4) or 1.5 N·m (M5).
- If the torque for terminal block screws exceeds 1.2 N·m (M4) or 2.0 N·m (M5), the terminal block may be damaged.
- Tighten the fixing screw of the terminal block cover to the torque of 0.2 N·m (M3).
- Tighten the ground screws to the torque of 0.7 to 0.8 N·m (M4) or 1.4 to 1.6 N·m (M5).
- Do not connect any External Regeneration Resistors between B1 and NC.

R88D-KN75H-ECT

● Terminal Block Specifications, Left Terminal Block (TB1)

Symbol	Name	Function	
L1	Main circuit power supply input	R88D-KN□H-ECT (7.5 kW): 3-phase 200 to 230 VAC (170 to 253 VAC) 50/60 Hz 280 to 325 VDC (238 to 357 VDC)	
L2			
L3			
B1	External Regeneration Resistor connection terminals	Connect an External Regeneration Resistor between B1 and B2.	
B2			
N*1			
U	Motor connection terminals	Red	These are the output terminals to the Servomotor. Be sure to wire them correctly.
V		White	
W		Blue	
⊕		Green/ Yellow	

*1 The symbol "N" is found on G5-series AC Servo Drives with unit version 2.1 or later.

● Terminal Block Specifications, Right Terminal Block (TB2)

Symbol	Name	Function
L1C	Control circuit power supply input	R88D-KN□H-ECT: Single-phase 200 to 230 VAC (170 to 253 VAC) 50/60 Hz 280 to 325 VDC (238 to 357 VDC)
L2C		
DB1	Dynamic Brake Resistor control terminals	These terminals are used to control the MC for externally connected dynamic brake resistance. The output contact specifications are 1 A max. at 300 VAC/100 VDC max. Connect them if required.
DB2		
DB3		Normally DB3 and DB4 are shorted.
DB4		When using an externally connected Dynamic Brake Resistor, remove the short bar from between DB3 and DB4.
⊕	Frame ground	This is the ground terminal. Ground it to 100 Ω or less.



Precautions for Correct Use

- Tighten the fixing screw of the terminal block cover to the torque of 1.5 N·m (M5).
- If the torque for terminal block screws exceeds 2.0 N·m (M5), the terminal block may be damaged.
- Tighten the fixing screw of the terminal block cover to the torque of 0.2 N·m (M3).
- Tighten the ground screw to a torque of 1.4 to 1.6 N·m (M5).
- Do not connect any External Regeneration Resistors between B1 and N (or NC).

R88D-KN150H-ECT

● Terminal Block Specifications, Top Terminal Block (TB1)

Symbol	Name	Function
L1C	Control circuit power supply input	R88D-KN□H-ECT: Single-phase 200 to 230 VAC (170 to 253 VAC) 50/60 Hz 280 to 325 VDC (238 to 357 VDC)
L2C		
DB1	Dynamic Brake Resistor control terminals	These terminals are used to control the MC for externally connected dynamic brake resistance. The output contact specifications are 1 A max. at 300 VAC/100 VDC max. Connect them if required.
DB2		

● Terminal Block Specifications, Bottom Terminal Block (TB2)

Symbol	Name	Function
L1	Main circuit power supply input	R88D-KN□H-ECT (7.5 kW): 3-phase 200 to 230 VAC (170 to 253 VAC) 50/60 Hz 280 to 325 VDC (238 to 357 VDC)
L2		
L3		
B1	External Regeneration Resistor connection terminals	Connect an External Regeneration Resistor between B1 and B2.
B2		
N*1		
U	Motor connection terminals	These are the output terminals to the Servomotor. Be sure to wire them correctly.
V		
W		
⊕		
⊕		
⊕	Frame ground	This is the ground terminal. Ground to 100 Ω or less.

*1 The symbol "N" is found on G5-series AC Servo Drives with unit version 2.1 or later.



Precautions for Correct Use

- Tighten the fixing screw of the terminal block cover to the torque of 1.5 N·m (M5) or 2.5 N·m (M6).
- If the torque for terminal block screws exceeds 2.0 N·m (M5) or 3.0 N·m (M6), the terminal block may be damaged.
- Tighten the fixing screw of the terminal block cover to the torque of 0.4 N·m (M5).
- Tighten the ground screw to a torque of 2.4 to 2.6 N·m (M6).
- Do not connect any External Regeneration Resistors between B1 and N (or NC).

R88D-KN06F-ECT/-KN10F-ECT/-KN15F-ECT/-KN20F-ECT

● Main Circuit Connector Specifications (CNA)

Symbol	Name	Function
L1	Main circuit power supply input	R88D-KN□F-ECT 600 W to 1.5 kW: 3-phase: 380 to 480 VAC (323 to 528 VAC) 50/60 Hz
L2		
L3		

● Motor Connector Specifications (CNB)

Symbol	Name	Function	
U	Motor connection terminals	Phase U	These are the output terminals to the Servomotor. Be sure to wire them correctly.
V		Phase V	
W		Phase W	

● Control Circuit Connector Specifications (CNC)

Symbol	Name	Function
24 V	Control circuit power supply input	24 VDC \pm 15%
0 V		

● External Regeneration Resistor Connector Specifications (CND)

Symbol	Name	Function
B1	External Regeneration Resistor connection terminals	Normally B2 and B3 are shorted. Do not short B1 and B2. Doing so may result in malfunctioning. If there is high regenerative energy, remove the short-circuit bar between B2 and B3 and connect an External Regeneration Resistor between B1 and B2.
B3		
B2		
NC	Do not connect.	



Precautions for Correct Use

- Do not connect any External Regeneration Resistors between B1 and NC.

R88D-KN30F-ECT/R88D-KN50F-ECT

● Main Circuit Terminal Block Specifications (TB1)

Symbol	Name	Function
24 V	Control circuit power supply input	24 VDC \pm 15%
0 V		

● Main Circuit Terminal Block Specifications (TB2)

Symbol	Name	Function
L1	Main circuit power supply input	R88D-KN□F-ECT (3 to 5 kW): 3-phase 380 to 480 VAC (323 to 528 VAC) 50/60 Hz
L2		
L3		
B1	External Regeneration Resistor connection terminals	A Regeneration Resistor is not built in. Connect an External Regeneration Resistor between B1 and B2 as required. Normally, do not short B1 and B2. Doing so may result in malfunctioning.
B3		
B2		
NC	Do not connect.	
U	Motor connection terminals	Phase U
V		Phase V
W		Phase W
		These are the output terminals to the Servomotor. Be sure to wire them correctly.



Precautions for Correct Use

- Tighten the terminal block screws to the torque of 0.75 N·m (M4) or 1.5 N·m (M5).
- If the torque for terminal block screws exceeds 1.2 N·m (M4) or 2.0 N·m (M5), the terminal block may be damaged.
- Tighten the fixing screw of the terminal block cover to the torque of 0.2 N·m (M3).
- Tighten the ground screws to the torque of 0.7 to 0.8 N·m (M4) or 1.4 to 1.6 N·m (M5).
- Do not connect any External Regeneration Resistors between B1 and NC.

R88D-KN75F-ECT

● Terminal Block Specifications, Left Terminal Block (TB1)

Symbol	Name	Function	
L1	Main circuit power supply input	R88D-KN□F-ECT (7.5 kW): 3-phase 380 to 480 VAC (323 to 528 VAC) 50/60 Hz	
L2			
L3			
B1	External Regeneration Resistor connection terminals	Connect an External Regeneration Resistor between B1 and B2.	
B2			
NC	Do not connect.		
U	Motor connection terminals	Red	These are the output terminals to the Servomotor. Be sure to wire them correctly.
V		White	
W		Blue	
⊕		Green/ Yellow	

● Terminal Block Specifications, Right Terminal Block (TB2)

Symbol	Name	Function
24 V	Control circuit power supply input	24 VDC \pm 15%
0 V		
DB1	Dynamic Brake Resistor control terminals	These terminals are used to control the MC for externally connected dynamic brake resistance. The output contact specifications are 1 A max. at 300 VAC/100 VDC max. Connect them if required.
DB2		
DB3		Normally DB3 and DB4 are shorted.
DB4		When using an externally connected Dynamic Brake Resistor, remove the short bar from between DB3 and DB4.
⊕	Frame ground	This is the ground terminal. Ground to 10 Ω or less.



Precautions for Correct Use

- Tighten the fixing screw of the terminal block cover to the torque of 1.5 N·m (M5).
- If the torque for terminal block screws exceeds 2.0 N·m (M5), the terminal block may be damaged.
- Tighten the fixing screw of the terminal block cover to the torque of 0.2 N·m (M3).
- Tighten the ground screw to a torque of 1.4 to 1.6 N·m (M5).
- Do not connect any External Regeneration Resistors between B1 and NC.

R88D-KN150F-ECT

● Terminal Block Specifications, Top Terminal Block (TB1)

Symbol	Name	Function
24 V	Control circuit power supply input	24 VDC \pm 15%
0 V		
DB1	Dynamic Brake Resistor control terminals	These terminals are used to control the MC for externally connected dynamic brake resistance. The output contact specifications are 1 A max. at 300 VAC/100 VDC max. Connect them if required.
DB2		

● Terminal Block Specifications, Bottom Terminal Block (TB2)

Symbol	Name	Function
L1	Main circuit power supply input	R88D-KN□F-ECT (15 kW): 3-phase 380 to 480 VAC (323 to 528 VAC) 50/60 Hz
L2		
L3		
B1	External Regeneration Resistor connection terminals	Connect an External Regeneration Resistor between B1 and B2.
B2		
NC	Do not connect.	
U	Motor connection terminals	These are the output terminals to the Servomotor. Be sure to wire them correctly.
V		
W		
⊕		
⊕	Frame ground	This is the ground terminal. Ground to 10 Ω or less.



Precautions for Correct Use

- Tighten the terminal block screws to the torque of 1.5 N·m (M5) or 2.5 N·m (M6).
- If the torque for terminal block screws exceeds 2.0 N·m (M5) or 3.0 N·m (M6), the terminal block may be damaged.
- Tighten the fixing screw of the terminal block cover to the torque of 0.4 N·m (M5).
- Tighten the ground screw to a torque of 2.4 to 2.6 N·m (M6).
- Do not connect any External Regeneration Resistors between B1 and NC.

3-1-5 EtherCAT Communications Connector Specifications (RJ45)

The EtherCAT twisted-pair cable is connected to a shielded connector.

- Electrical characteristics: Confirm to IEEE 802.3.
- Connector structure: RJ45 8-pin modular connector (conforms to ISO 8877)

	Pin No.	Signal name	Abbreviation	Direction
	1	Send data +	TD+	Output
	2	Send data –	TD–	Output
	3	Receive data +	RD+	Input
	4	Not used	–	–
	5	Not used	–	–
	6	Receive data –	RD–	Input
	7	Not used	–	–
	8	Not used	–	–
	Connector hood	Protective ground	FG	–

3-1-6 Control I/O Connector Specifications (CN1)

Control I/O Signal Connections and External Signal Processing

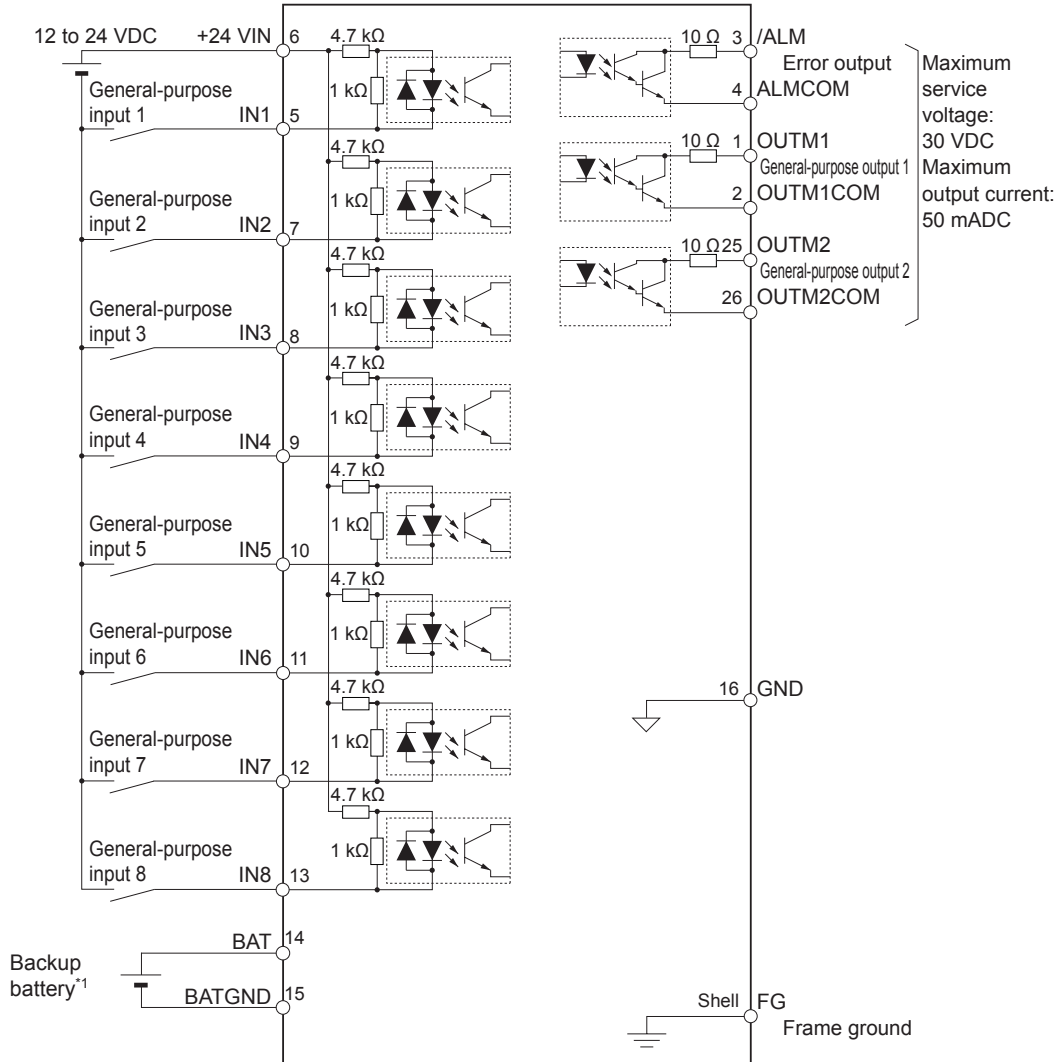

*1 A cable equipped with a battery is not required if a backup battery is connected.

Note 1 The input function of pins 5 and 7 to 13 are determined by object settings.

2 The output function of pins 1, 2, 25 and 26 are determined by object settings.

3 It is not necessary to wire input pins that are not being used.

Control I/O Signal Tables

● CN1 Control Inputs

Pin number	Symbol	Signal		Function and interface
		Name	Default	
6	+24 VIN	Power supply input 12 to 24 VDC.		The positive input terminal of the external power supply (12 to 24 VDC) for sequence inputs
5	IN1	General-purpose Input 1	Immediate Stop Input	These are general-purpose inputs. The input functions can be selected with objects. External Latch Signals 1 to 3 can be allocated only to IN5 to IN7 (or pins 10 to 12) respectively. Refer to <i>7-1 Sequence I/O Signals</i> on page 7-2 for the allocations.
7	IN2	General-purpose Input 2	Forward Drive Prohibition Input	
8	IN3	General-purpose Input 3	Reverse Drive Prohibition Input	
9	IN4	General-purpose Input 4	Origin Proximity Input	
10	IN5	General-purpose Input 5	External Latch Signal 3	
11	IN6	General-purpose Input 6	External Latch Signal 2	
12	IN7	General-purpose Input 7	External Latch Signal 1	
13	IN8	General-purpose Input 8	Monitor Input 0	
14	BAT	Backup battery input	ABS	Backup battery connection terminals when the absolute encoder power is interrupted. (Connection to this terminal is not necessary if you use the absolute encoder battery cable for backup.)
15	BATGND			

● CN1 Control Outputs

Pin number	Symbol	Signal		Function and interface
		Name	Default	
3	/ALM	Error Output		The output turns OFF when an error occurs in the Servo Drive.
4	ALMCOM			
1	OUTM1	General-purpose Output 1	Brake Interlock Output	These are general-purpose outputs. The output functions can be selected with objects. Refer to <i>7-1 Sequence I/O Signals</i> on page 7-2 for the allocations.
2	OUTM1COM			
25	OUTM2	General-purpose Output 2	Servo Ready Output	
26	OUTM2COM			
16	GND	Signal Ground		This is the signal ground.

CN1 Pin Arrangement

2	OUTM1COM	General-purpose Output 1 Common	1	OUTM1 (BKIR)	General-purpose Output 1 (Brake Interlock Output)	14	BAT	Absolute Encoder Backup Battery Input
4	ALMCOM	Error Output Common	3	/ALM	Error Output	15	BATGND	Absolute Encoder Backup Battery Input
6	+24 VIN	12 to 24-VDC Power Supply Input	5	IN1 (STOP)	General-purpose Input 1 (Immediate Stop Input)	16	GND	Signal Ground
8	IN3 (NOT)	General-purpose Input 3 (Reverse Drive Prohibition Input)	7	IN2 (POT)	General-purpose Input 2 (Forward Drive Prohibition Input)	17	*	*
10	IN5 (EXT3)	General-purpose Input 5 (External Latch Input 3)	9	IN4 (DEC)	General-purpose Input 4 (Origin Proximity Input)	18	*	*
12	IN7 (EXT1)	General-purpose Input 7 (External Latch Input 1)	11	IN6 (EXT2)	General-purpose Input 6 (External Latch Input 2)	19	*	*
			13	IN8 (MON0)	General-purpose Input 8 (Monitor Input 0)	20	*	*
						21	*	*
						22	*	*
						23	*	*
						24	*	*
						25	OUTM2 (READY)	General-purpose Output 2 (Servo Ready Output)
						26	OUTM2COM	General-purpose Output 2 Common

Note Do not connect anything to unused pins (those marked with *).

The input functions for general-purpose inputs 1 to 8 (or IN1 to IN8) and the output functions for general-purpose outputs (OUTM1 and OUTM2) are determined by the objects 3400 to 3407 hex (Input Signal Selection 1 to 8) and objects 3410 and 3411 hex (Output Signal Selection 1 and 2). The functions that are allocated by default are given in parentheses. Refer to *7-1 Sequence I/O Signals* on page 7-2 for the allocation.

To use an absolute encoder, connect a battery to pin 14 and 15, which is the backup battery input, or connect the battery to the holder of the absolute encoder cable. (Never connect to both.)

Connectors for CN1 (Pin 26)

Name	Model	Manufacturer	OMRON model number
Plug	10126-3000PE	Sumitomo 3M	R88A-CNW01C
Cable Case	10326-52A0-008		

3-1-7 Control Input Circuits

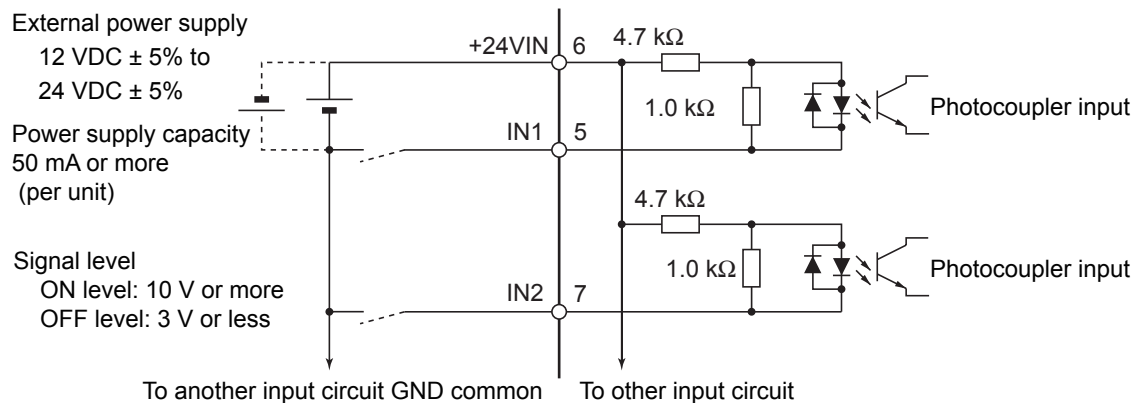

3-1-8 Control Input Details

This is the detailed information about the CN1 connector input pins.

General-purpose Inputs (IN1 to IN8)

Pin 5:	General-purpose Input 1 (IN1)	[Immediate Stop Input (STOP)]
Pin 7:	General-purpose Input 2 (IN2)	[Forward Drive Prohibition Input (POT)]
Pin 8:	General-purpose Input 3 (IN3)	[Reverse Drive Prohibition Input (NOT)]
Pin 9:	General-purpose Input 4 (IN4)	[Origin Proximity Input (DEC)]
Pin 10:	General-purpose Input 5 (IN5)	[External Latch Input 3 (EXT3)]
Pin 11:	General-purpose Input 6 (IN6)	[External Latch Input 2 (EXT2)]
Pin 12:	General-purpose Input 7 (IN7)	[External Latch Input 1 (EXT1)]
Pin 13:	General-purpose Input 8 (IN8)	[Monitor Input 0 (MON0)]

Note The functions that are allocated by default are given in brackets.

Refer to *7-1 Sequence I/O Signals* on page 7-2 for the allocation procedures.

● Immediate Stop Input (STOP)

- STOP is used when an external sequence such as the host forcibly turns OFF the servo.
- If the Immediate Stop Input (STOP) turns ON during Servomotor rotation, the dynamic brake makes a deceleration stop. After the motor stops, it remains in servo-free state.
- If the Immediate Stop Input (STOP) turns ON when the motor is energized, an Immediate Stop Input Error (Error No. 87.0) will occur.
- This input is allocated to the pin 5 with the NC contact in the default setting.



Precautions for Safe Use

Turn ON the Immediate Stop Input (STOP) at the same time as when you turn OFF the main power. When the main power turns OFF due to an external immediate stop, the motor will continue to rotate due to residual voltage. This may cause human injury or damage to the machine and devices.

● Forward Drive Prohibition Input (POT) and Reverse Drive Prohibition Input (NOT)

- These two signals are the inputs to prohibit forward and reverse rotation (over-travel inputs).
- When these terminals are shorted (factory setting), the Servo Drive can rotate in the specified direction.
- In the drive prohibition state, Servomotor switches to servo lock state after a deceleration stop.
- The maximum torque for a deceleration stop is the same as the maximum Servomotor torque.
- In the drive prohibition state, the Servo Drive does not switch to an error state.
- When the Drive Prohibition Input Selection (3504 hex) is set to 1, the operation at a drive prohibit input can be selected in the Stop Selection for Drive Prohibition Input (3505 hex).
- If the Drive Prohibition Input Selection (3504 hex) is set to 2, a Drive Prohibition Input Error (Error No. 38.0) will occur when there is a drive prohibition input.
- With the default settings, the Forward Drive Prohibition Input (POT) is allocated to pin 7, and the Reverse Drive Prohibition Input (NOT) is allocated to pin 8.



Precautions for Correct Use

Both signals are disabled (in a state in which drive prohibition will not operation) in the default settings. If prohibiting the drive input is required, set the Drive Prohibit Input Selection (3504 hex) to either 0 or 2. The setting on the Input Signal Selection 1 to 10 (3400 to 3409 hex) can change the logic and allocation for the respective Input terminals (CN1 to 7 and 8).

● Origin Proximity Input (DEC)

- This is the deceleration signal for origin returns.
- If the Origin Proximity Input turns ON while the Servomotor is traveling at the origin proximity input search speed, it will decelerate to the Speed during search for zero (6099 hex).
- With the default settings, the Origin Proximity Input is assigned to pin 9.

● External Latch Input Signals (EXT1, EXT2, and EXT3)

- These are the external input signals to latch the actual value in the feedback pulse counter.
- The encoder position data is obtained when the External Latch Input is turned ON.
- With the default settings, External Latch Input 1 is allocated to pin 12, External Latch Input 2 to pin 11, and External Latch Input 3 to pin 10.



Precautions for Correct Use

- The external latch inputs are detected by on the rising edge of the signal, but the minimal signal ON and OFF widths must be 2 ms.
 - The external latch inputs can only be set to NO (normally open) contacts.
 - The external latch inputs can be allocated to pins 10 to 12 only.
-

● Monitor Inputs (MON0, MON1, and MON2)

- These are the general-purpose monitor inputs.
- The general-purpose monitor inputs do not affect operation and can be monitored from the host controller.
- With the default settings, MON0 is allocated to pin 13.

● Forward External Torque Limit Input (PCL) and Reverse External Torque Limit Input (NCL)

- Turn ON these inputs to limit the torque to the value set in the Forward External Torque Limit (3525 hex) and the Reverse External Torque Limit (3526 hex).
- While the input is ON, operation continues within the torque limit.
- With the default settings, the inputs are not allocated.

Backup Battery Inputs (BAT)

Pin 14: Backup Battery + Input (BAT)

Pin 15: Backup Battery – Input (BATGND)

● Function:

- These are the backup battery connection terminals used when the absolute encoder power is interrupted.
- If a battery is connected to the battery holder for the absolute encoder battery cable, do not connect anything to these terminals.



Precautions for Correct Use

Be sure not to connect to both of the absolute encoder battery cable and the backup battery inputs at the same time. Such connection may result in malfunction.

3-1-9 Control Output Circuits

Sequence Outputs

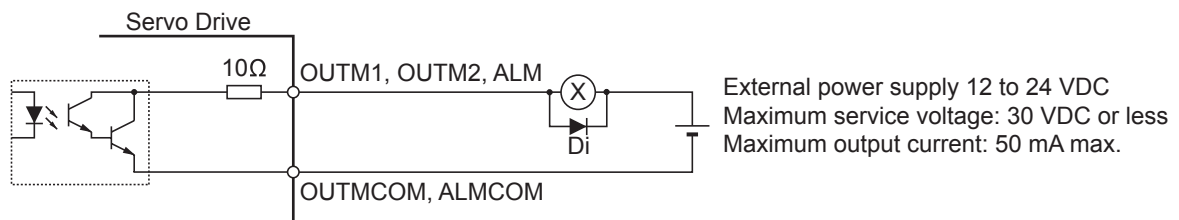

Di: Surge voltage prevention diode*1

*1 When driving a relay directly with an output signal, always insert a diode as shown in the above figure. Use high-speed diodes.

3-1-10 Control Output Details

Control Output Sequence

The chart below illustrates the timing of the command inputs after the control power supply is turned ON. Input the Servo ON/OFF operation, position, speed, and torque commands in the correct timing, as shown in the chart.

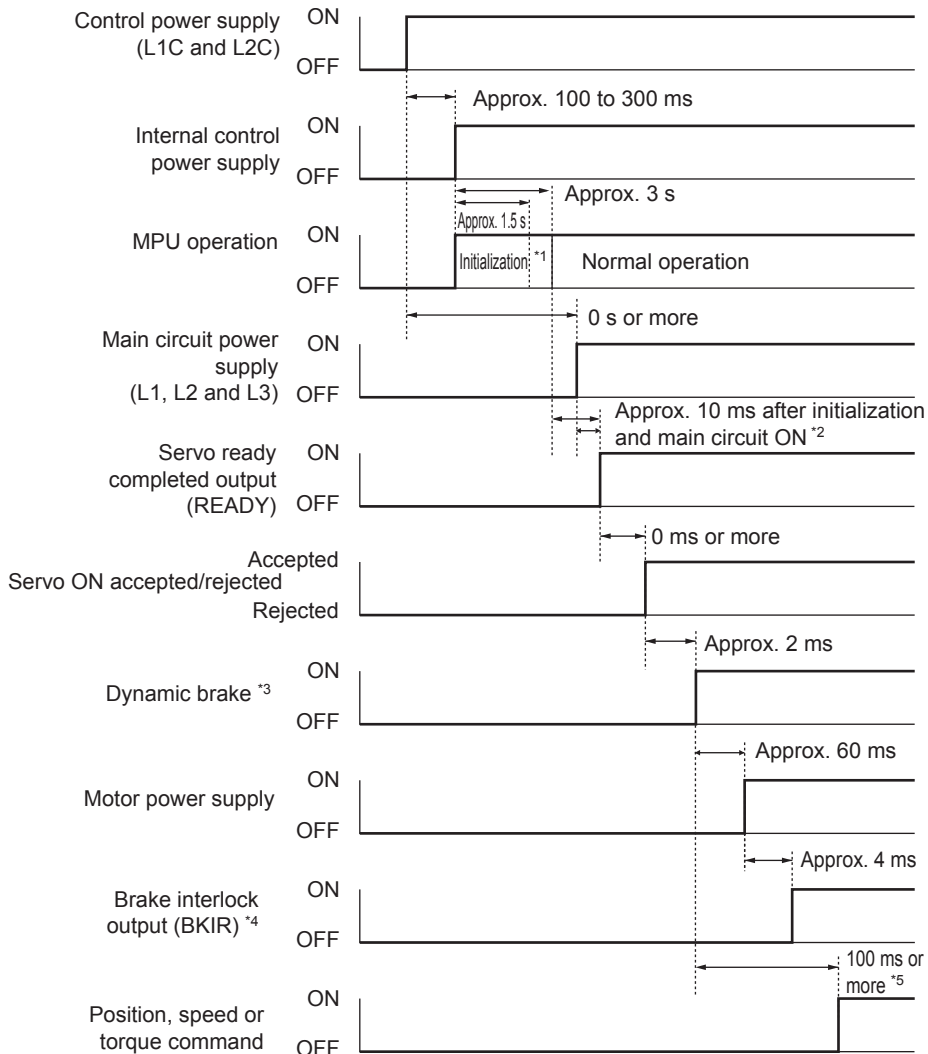

- *1 Once the internal control power is established, the protective function starts working about 1.5 s after the MPU starts initializing itself. Be sure that all I/O signals that are connected to the Servo Drive, especially the Forward/Reverse Drive Prohibition Input (POT/NOT), the Origin Proximity Input (DEC), the external encoder input, are stable before the protective function starts working. The period can be extended by setting the Power Supply ON Initialization Time (3618 hex).
- *2 The Servo Ready Completed Output (READY) turns ON only when all of these conditions are met: MPU initialization is completed. The main power supply is established. No error exists. EtherCAT communications and servo are synchronized (phase alignment).
- *3 The above timing chart applies when the servo ON signal is accepted as soon as doing so is enabled.
- *4 The Brake Interlock Output (BKIR) turns ON either when a release request is received via servo controls or when a release request is received via EtherCAT communications.
- *5 Although the servo ON operation is accepted in this section, it is not yet enabled.

Error Output (/ALM)

Pin 3:	Error Output (/ALM)
Pin 4:	Error Output Common (ALMCOM)

● Function

- This output is turned OFF when the drive detects an error.
- This output is OFF when the power supply is turned ON, but turns ON when the drive's initial processing has been completed.

General-purpose Outputs (OUTM1 and OUTM2)

Pin 1:	General-purpose Output 1 (OUTM1) – [Brake Interlock Output (BKIR)]
Pin 2:	General-purpose Output 1 Common (OUTM1COM)
Pin 25:	General-purpose Output 2 (OUTM2) – [Servo Ready Output (READY)]
Pin 26:	General-purpose Output 2 Common (OUTM2COM)

Note The functions that are allocated by default are given in brackets.

Refer to the description in Output Signals in *7-1 Sequence I/O Signals* on page 7-2 for the allocations.

● Servo Ready Completed Output (READY)

- This output signal indicates the Servo Drive is ready to supply power to the Servomotor.
- It turns ON when no error is detected after the main circuit power supply turns ON.
- With the default settings, the output is allocated to pins 25 and 26.

● Brake Interlock Output (BKIR)

- The Brake Interlock Output outputs the external brake timing signal according to the settings of the Brake Timing When Stopped (3437 hex), the Brake Timing During Operation (3438 hex), and the Brake Threshold Speed During Operation (3439 hex).
- With the default settings, the output is allocated to pins 1 and 2.

● Positioning Completion Output (INP1 and INP2)

- INP1 will turn ON when the position error is equal to or less than Position window (6067 hex).
- INP2 will turn ON when the position error is equal to or less than Positioning Completion Range 2 (3442 hex).
- The INP1 output turns ON according to Positioning Completion Condition Selection (3432 hex).
- The output is always OFF except in position control mode.
- With the default settings, the output is not allocated.

● Motor Rotation Speed Detection Output (TGON)

- It turns on when the motor rotation speed exceeds the value set by the Rotation Speed for Motor Rotation Detection (3436 hex).
- The output is effective both in forward and reverse directions regardless the actual direction that the motor rotates.
- The detection contains a hysteresis of 10 r/min.
- With factory setting, the output is not allocated.

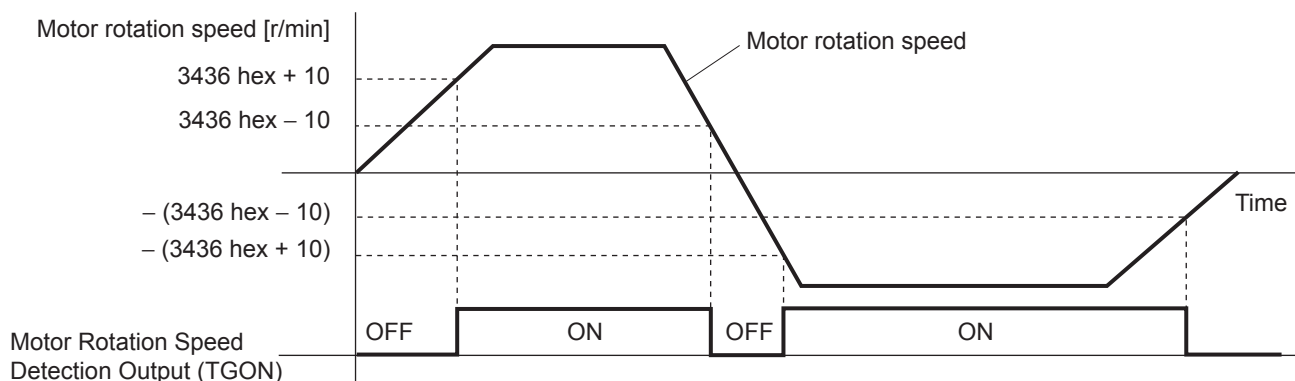

● Torque Limit Output (TLIMIT)

- The output turns ON when the output torque reaches the limit set in the Positive torque limit value (60E0 hex) or the Negative torque limit value (60E1 hex).
- With the default settings, the output is not allocated.

● Zero Speed Detection Output (ZSP)

- It turns ON when the motor rotation speed goes below the value set by the Zero Speed Detection (3434 hex).
- The output is effective both in forward and reverse directions regardless of the actual direction that the motor rotates.
- The detection contains a hysteresis of 10 r/min.
- With the default settings, the output is not allocated.

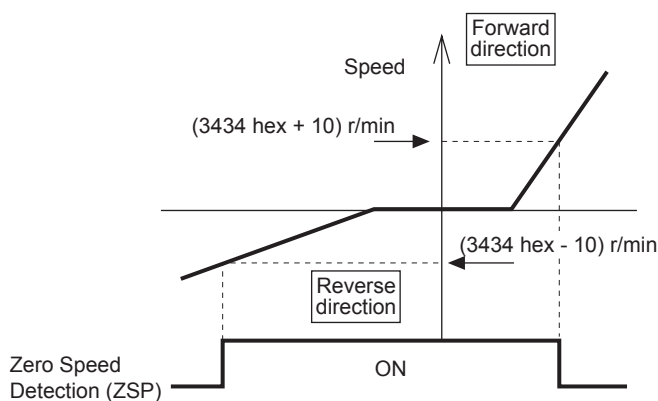

● Speed Conformity Output (VCMP)

- The output turns ON when the motor rotation speed falls into the range set by the Speed Conformity Detection Range (3435 hex).
- It is determined to be conforming when the difference between the commanded speed before acceleration or deceleration process inside the Drive and the motor rotation speed is within the set range of Speed Conformity Detection Range (3435 hex).
- A hysteresis of 10 r/min is set for the detection.
- The output is always OFF except in the Position Control Mode (including the Fully-closed Control Mode).
- With factory setting, the output is not allocated.

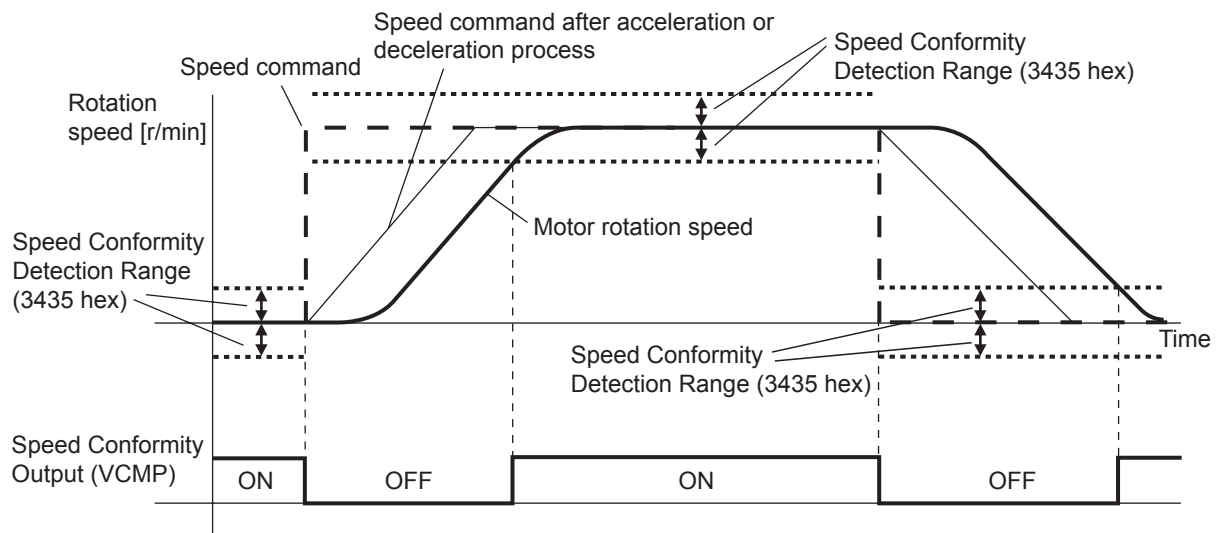

● Warning Outputs (WARN1 and WARN2)

- The Warning Output 1 (WARN1) turns ON when the warning set by the Warning Output Selection 1 (3440 hex) is detected.
- The Warning Output 2 (WARN2) turns ON when the warning set by the Warning Output Selection 2 (3441 hex) is detected.
- With the default settings, the outputs are not allocated.

● Position Command Status Output (PCMD)

- This output turns ON when a position command is issued in Profile position mode (pp).
- The output is always OFF except in Profile position mode (pp).
- With the default settings, the output is not allocated.

● Speed Limiting Output (VLIMIT)

- This output turns ON when the motor speed reaches the limit set in the Speed Limit Value Setting (3321 hex).
- The output is always OFF except in torque control mode.
- With the default settings, the output is not allocated.

● Error Clear Attribute Output (ALM-ATB)

- This output turns ON when an error that can be reset occurs.
- With the default settings, the output is not allocated.

● Speed Command Status Output (VCMD)

- This output turns ON when a speed command is issued in speed control mode.
- The output is always OFF except in speed control mode.
- With the default settings, the output is not allocated.

● Remote Outputs (R-OUT1 and R-OUT2)

- Remote Output 1 (R-OUT1) turns ON and OFF according to the ON/OFF status of bit 16 in the Digital outputs (60FE hex).
- Remote Output 2 (R-OUT2) turns ON and OFF according to the ON/OFF status of bit 17 in the Digital outputs (60FE hex).
- With the default settings, the output is not allocated.

3-1-11 Encoder Connector Specifications (CN2)

Pin No.	Symbol	Name	Function and interface
1	E5V	Encoder power supply +5 V	Power supply output for the encoder
2	E0V	Encoder power supply GND	
3	BAT+	Battery +	Backup power supply output for the absolute encoder
4	BAT-	Battery -	
5	PS+	Encoder + phase S input	Encoder signal I/O (serial signal)
6	PS-	Encoder - phase S input	
Shell	FG	Frame ground	Frame ground

● Connectors for CN2 (6 Pins)

Name	Model	Manufacturer	OMRON model number
Drive connector	53460-0629	Molex Japan	-
Cable connector	55100-0670		R88A-CNW01R

3-1-12 External Encoder Connector Specifications (CN4)

These are the specifications of the connector that connect with the external encoder.

Pin No.	Symbol	Name	Function and interface
1	E5V	External encoder power supply output	Use at $5.2\text{ V} \pm 5\%$ and at or below 250 mA.
2	E0V		This is connected to the control circuit ground connected to connector CN1.
3	+EXS	External encoder signal I/O (serial signal)	Perform serial signal input and output.
4	-EXS		
5	+EXA	External encoder signal input (phase A, B, and Z signals)	Perform input and output of phase A, B, and Z signals.
6	-EXA		
7	+EXB		
8	-EXB		
9	+EXZ		
10	-EXZ		
Shell	FG	Frame ground	Frame ground

● Connectors for CN4 (10 Pins)

Name	Model	Manufacturer	OMRON model number
MUF Connector	MUF-PK10K-X	JST Mfg. Co., Ltd.	R88A-CNK41L

External Encoder Input Signal Table

External Encoder I/O (CN4)

Pin No.	Symbol	Name	Function and interface
1	E5V	External encoder power supply output	External encoder power supply: 5.2 VDC \pm 5%, 250 mA max. If the above capacity is exceeded, provide a separate power supply.
2	E0V		
3	+EXS	External encoder signal serial interface	This is an external encoder serial bi-directional signal. ^{*1} (Conforms to EIA485) Maximum response frequency: 400 Mpps
4	-EXS		
5	+EXA	External encoder signal 90° phase difference input (Phases A, B and Z)	This is an external encoder 90 phase input signal. ^{*1} Maximum response frequency: 4 Mpps (quadruple multiplier)
6	-EXA		
7	+EXB		
8	-EXB		
9	+EXZ		
10	-EXZ		
Shell	FG	Frame ground	Frame ground

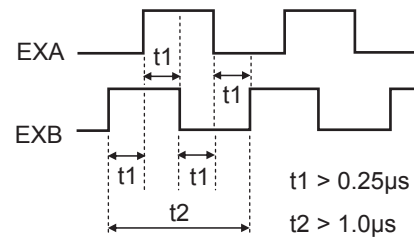

*1 Connect external encoder signals to the serial interface (+EXS/-EXS) or 90° phase difference inputs according to the encoder type.

Example of Connection with External Encoder

90° Phase Difference Output (3323 Hex = 0)

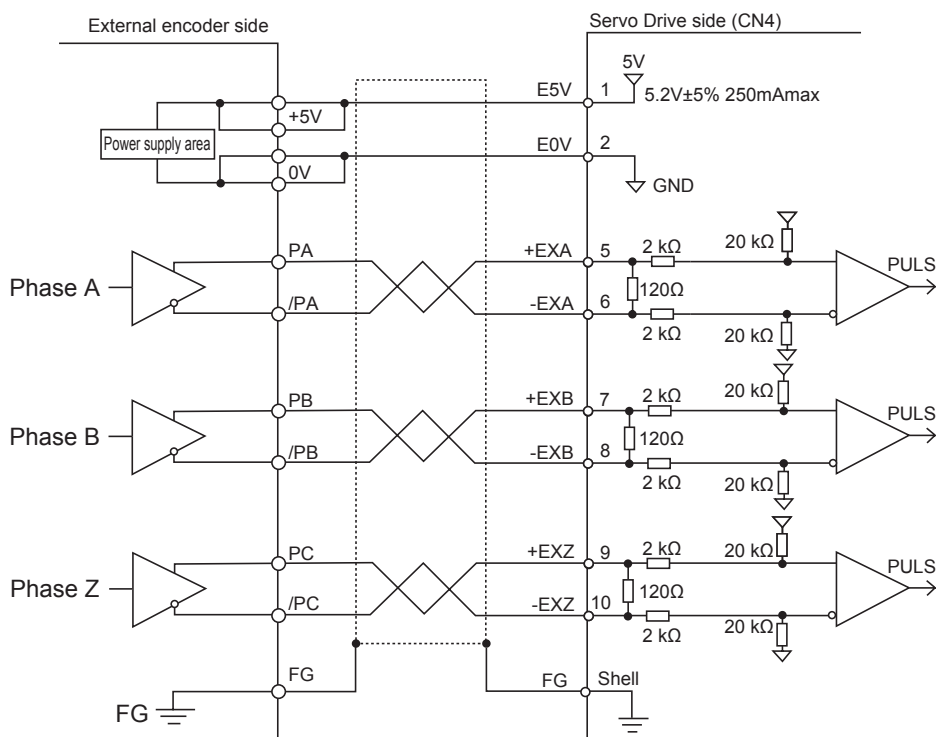

● Serial Communications, Incremental Encoder Specifications (3323 Hex = 1)

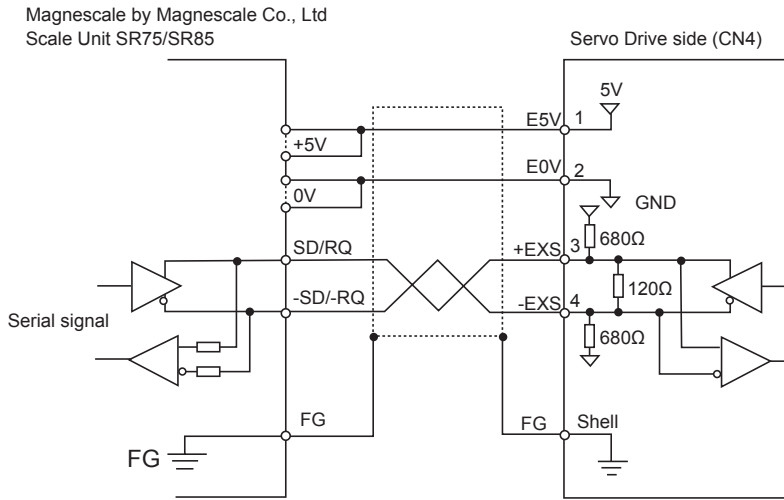

● Serial Communications, Absolute Encoder Specifications (3323 Hex = 2)

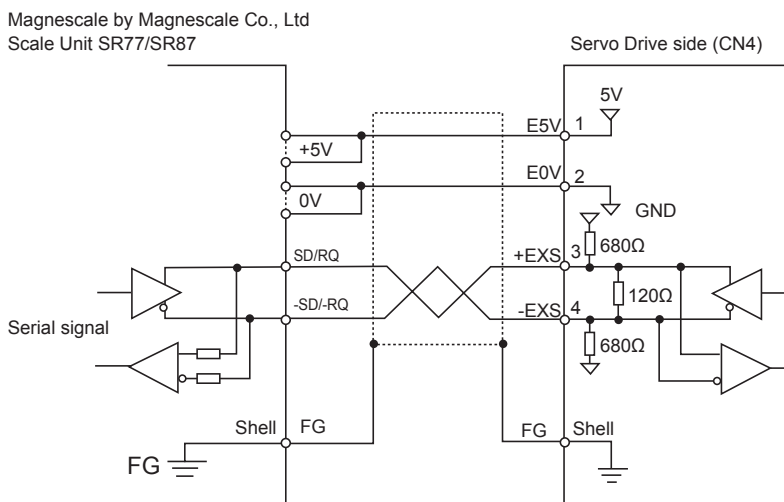
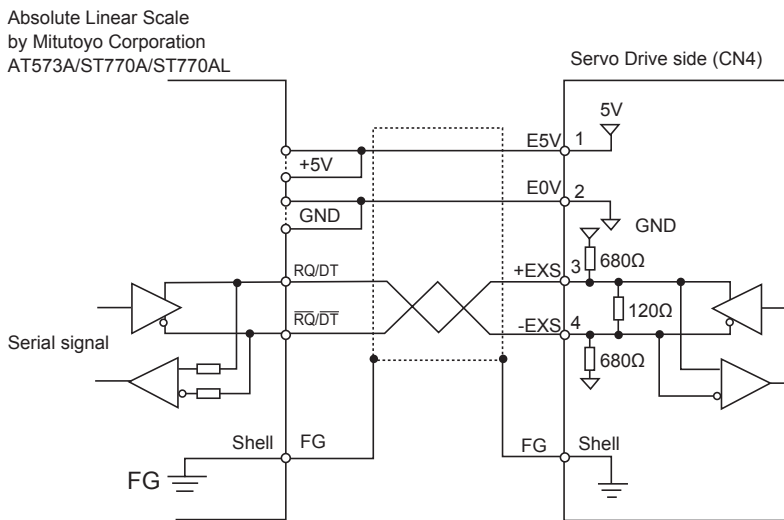

3-1-13 Analog Monitor Connector Specifications (CN5)

Monitor Output Signal Table

● Monitor Output (CN5)

Pin No.	Symbol	Name	Function and interface
1	AM1	Analog monitor output 1	Outputs the analog signal for the monitor. Default setting: Motor rotation speed 1 V/(500 r/min) You can use objects 3416 hex and 3417 hex to change the item and unit. You can use object 3421 hex to change the output method.
2	AM2	Analog monitor output 2	Outputs the analog signal for the monitor. Default setting: Torque command 1 V/(33 %) You can use objects 3418 hex and 3419 hex to change the item and unit. You can use object 3421 hex to change the output method.
3	GND	Analog monitor ground	Ground for analog monitors 1, 2
4	–	Not used	Do not connect.
5	–	Not used	Do not connect.
6	–	Not used	Do not connect.

● Connectors for CN5 (6 pins)

Name	Model	Manufacturer
Connector housing	51004-0600	Molex Japan
Connector terminal	50011-8000	Molex Japan

Monitor Output Circuit

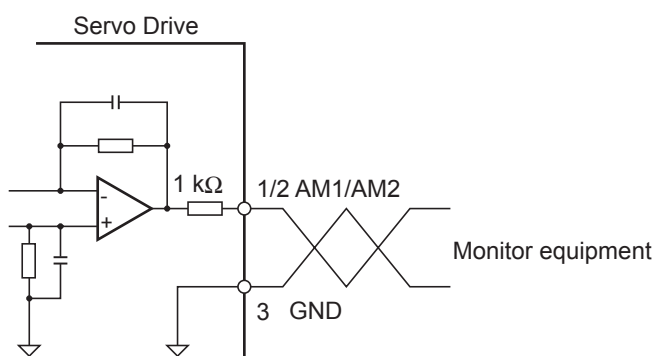

3-1-14 USB Connector Specifications (CN7)

Through the USB connection with computer, operations such as parameter setting and changing, monitoring of control status, checking error status and error history, and parameter saving and loading can be performed.

Pin No.	Symbol	Name	Function and interface
1	VBUS	USB signal terminal	Use this function for computer communication.
2	D-		
3	D+		
4	-	Reserved for manufacturer use	Do not connect.
5	GND	Signal ground	Signal ground



Precautions for Correct Use

- Use a commercially available USB cable that is shielded, equipped with a ferrite core for noise immunity, and supports USB2.0.
The Mini B type USB cable can be used.

3-1-15 Safety Connector Specifications (CN8)

Connection of Safety I/O Signals and Processing of External Signals

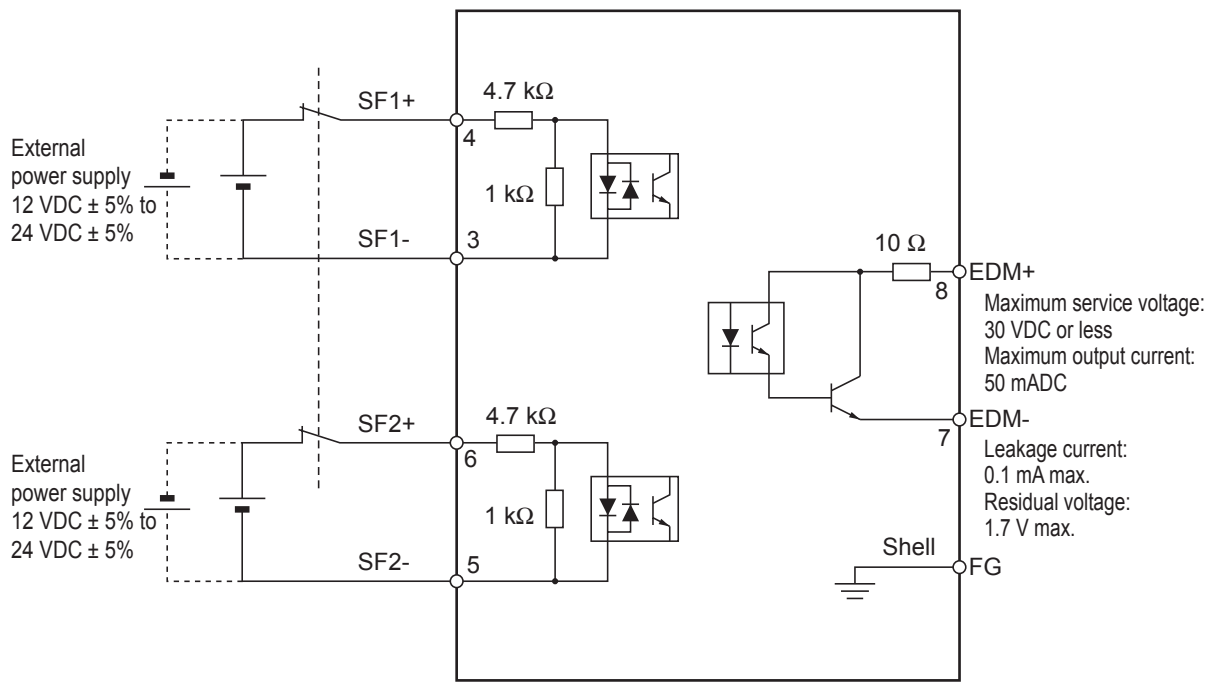

Safety I/O Signal Table

● Safety I/O (CN8)

Pin No.	Symbol	Name	Function and interface
1	-	Reserved	Do not connect.
2	-	Reserved	
3	SF1-	Safety input 1	Inputs 1 and 2 for operating the STO function, which are 2 independent circuits. This input turns OFF the power transistor drive signals in the Servo Drive to cut off the current output to the motor.
4	SF1+		
5	SF2-	Safety input 2	
6	SF2+		
7	EDM-	EDM output	A monitor signal is output to detect a safety function failure.
8	EDM+		
Shell	FG	Frame ground	Connected to the ground terminal inside the Servo Drive.

● Connector for CN8 (8 pins)

Name	Model	Manufacturer	OMRON model number
Industrial Mini I/O Connector (D-SHAPE1)	2013595-1	Tyco Electronics AMP KK	R88A-CN81S

Note The recommended cable is a 6-core shielded cable with a wire size of AWG30 to AWG26 and a finished outer diameter of 6.7 mm or less.

Safety Input Circuits

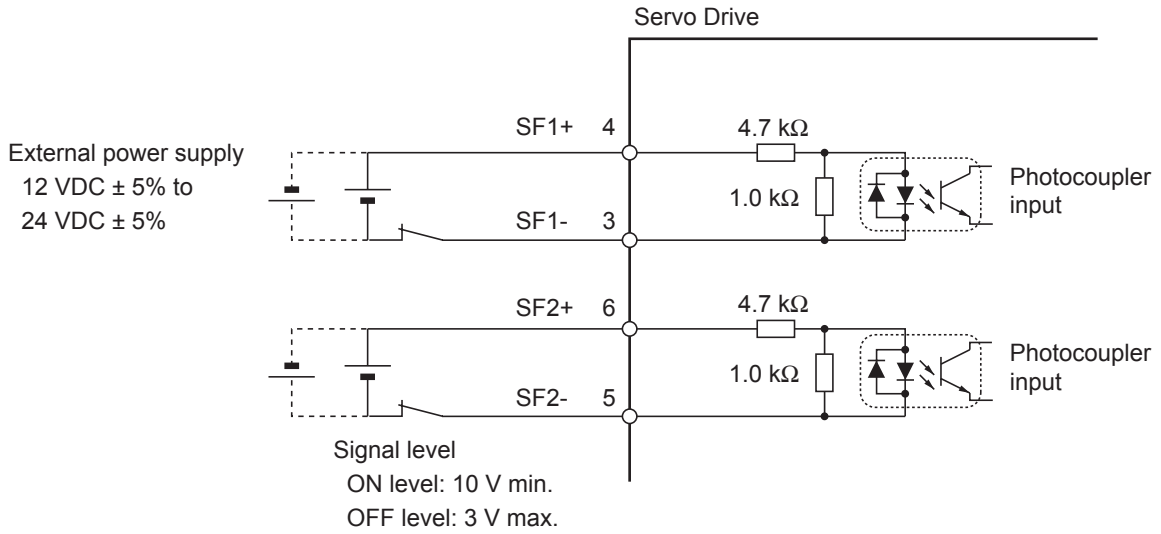

EDM Output Circuit

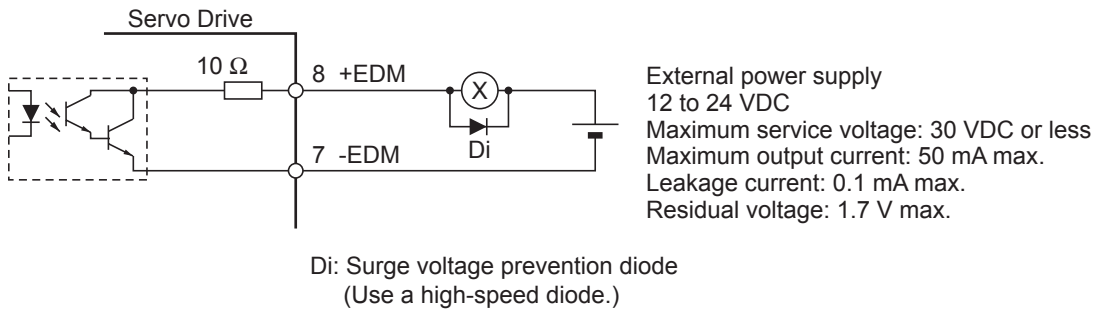

Note When driving a relay directly with an output signal, always insert a diode as shown in the above figure.

3-2 Overload Characteristics (Electronic Thermal Function)

An overload protection function (electronic thermal) is built into the Servo Drive to protect the drive and motor from overloading. If an overload does occur, first eliminate the cause of the error and then wait at least 1 minute for the motor temperature to drop before turning ON the power again. If the error reset is repeated at short intervals, the motor windings may burn out.

3-2-1 Overload Characteristics Graphs

The following graphs show the characteristics of the load ratio and electronic thermal function's operation time.

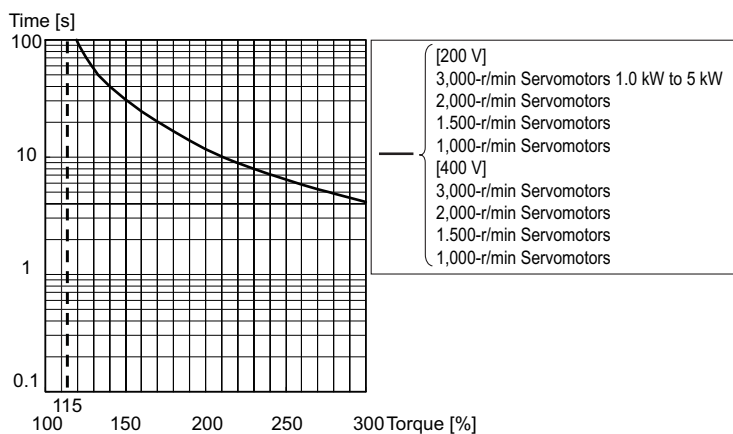
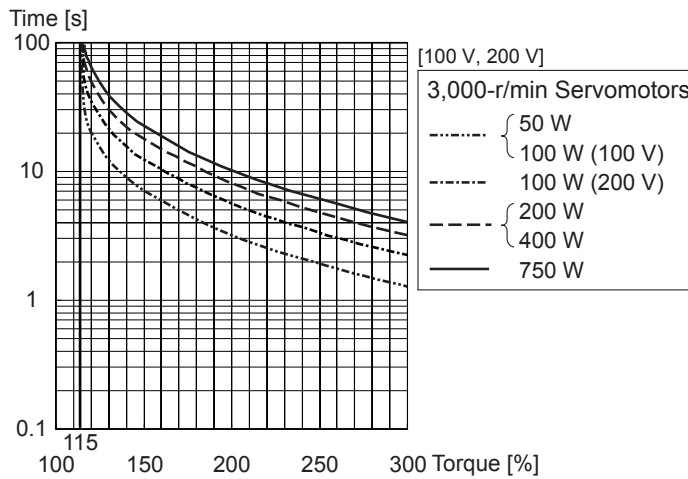

When the torque command = 0, and a constant torque command is continuously applied after 3 or more times the overload time constant has elapsed, the overload time t [s] is

$$t [s] = -\text{Overload time constant [s]} \times \log_e (1 - \text{Overload level [\%]} / \text{Torque command [\%]})^2$$

(The overload time constant [s] depends on the motor. The standard overload level is 115%.)

3-3 Servomotor Specifications

The following G5-Series AC Servomotors are available.

- 3,000-r/min Servomotors
- 1,500-r/min Servomotors
- 2,000-r/min Servomotors
- 1,000-r/min Servomotors

There are various options available, such as models with brakes, or different shaft types.

Select a Servomotor based on the mechanical system's load conditions and the installation environment.

3-3-1 General Specifications

Item	3,000-r/min Servomotors		1,000-r/min Servomotors 1,500-r/min Servomotors 2,000-r/min Servomotors
	50 to 750 W	1 to 5 kW	900 W to 15 kW
Ambient operating temperature and operating humidity	0 to 40°C, 20% to 85% (with no condensation)		
Storage ambient temperature and humidity	-20 to 65°C, 20% to 85% (with no condensation) Maximum temperature: 80°C for 72 hours		
Operating and storage atmosphere	No corrosive gases		
Vibration resistance *1	Acceleration of 49 m/s ² 24.5 m/s ² max. in X, Y, and Z directions when the motor is stopped		
Impact resistance	Acceleration of 98 m/s ² max. 3 times each in X, Y, and Z directions		
Insulation resistance	Between power terminal and FG terminal: 20 MΩ min. (at 500 VDC)		
Dielectric strength	1,500 VAC between power terminal and FG terminal for 1 min (voltage 100 V, 200 V) 1,800 VAC between power terminal and FG terminal for 1 min (voltage 400 V) 1,000 VAC between brake terminal and FG terminal for 1 min		
Insulation class	Class B	Class F	
Protective structure	IP67 (except for through-shaft parts and motor and encoder connector pins)		
International standard	EC Directives	Low Voltage Directive	EN 60034-1/-5
	UL standards		UL1004-1
	CSA standards		CSA22.2 No. 100
			UL1004-1, UL1004-6*2

*1 The amplitude may be increased by machine resonance. As a guideline, do not exceed 80% of the specified value.

*2 UL1004-6 applies only to 1,500-r/min Servomotors of 7.5 to 15 kW and 1,000 r/min Servomotors of 4.5 to 6 kW.

Note 1 Do not use the cable when it is laying in oil or water.

2 Do not expose the cable outlet or connections to stress due to bending or the weight of the cable itself.

3-3-2 Characteristics

3,000-r/min Servomotors

Model (R88M-)			100 VAC			
			K05030H	K10030L	K20030L	K40030L
Item	Unit	K05030T	K10030S	K20030S	K40030S	
Rated output *1	W	50	100	200	400	
Rated torque *1	N · m	0.16	0.32	0.64	1.3	
Rated rotation speed	r/min	3,000				
Maximum rotation speed	r/min	6,000				
Momentary maximum torque *1	N · m	0.48	0.95	1.91	3.8	
Rated current *1	A (rms)	1.1	1.6	2.5	4.6	
Momentary maximum current *1	A (rms)	4.7	6.9	10.6	19.5	
Rotor inertia	Without brake	kg · m ²	0.025 × 10 ⁻⁴	0.051 × 10 ⁻⁴	0.14 × 10 ⁻⁴	0.26 × 10 ⁻⁴
	With brake	kg · m ²	0.027 × 10 ⁻⁴	0.054 × 10 ⁻⁴	0.16 × 10 ⁻⁴	0.28 × 10 ⁻⁴
Applicable load inertia	–	30 times the rotor inertia max. *2				
Torque constant *1	N · m/A	0.11±10%	0.14±10%	0.20±10%	0.21±10%	
Power rate *1	Without brake	kW/s	10.1	19.8	28.9	62.3
	With brake	kW/s	9.4	18.7	25.3	57.8
Mechanical time constant	Without brake	ms	1.43	1.03	0.61	0.48
	With brake	ms	1.54	1.09	0.70	0.52
Electrical time constant	ms	0.82	0.91	3.0	3.4	
Allowable radial load *3	N	68	68	245	245	
Allowable thrust load *3	N	58	58	98	98	
Weight	Without brake	kg	Approx. 0.31	Approx. 0.45	Approx. 0.78	Approx. 1.2
	With brake	kg	Approx. 0.51	Approx. 0.65	Approx. 1.2	Approx. 1.6
Radiator plate dimensions (material)		100 × 80 × t10 (Al)		130 × 120 × t12 (Al)		
Applicable drives (R88D-)		KNA5L-ECT	KN01L-ECT	KN02L-ECT	KN04L-ECT	
Brake specifications	Brake inertia	kg · m ²	2 × 10 ⁻⁷	2 × 10 ⁻⁷	1.8 × 10 ⁻⁶	1.8 × 10 ⁻⁶
	Excitation voltage *4	V	24 VDC ± 10%			
	Power consumption (at 20°C)	W	7	7	9	9
	Current consumption (at 20°C)	A	0.3	0.3	0.36	0.36
	Static friction torque	N · m	0.29 min.	0.29 min.	1.27 min.	1.27 min.
	Attraction time *5	ms	35 max.	35 max.	50 max.	50 max.
	Release time *5	ms	20 max.	20 max.	15 max.	20 max.
	Backlash		± 1°			
	Allowable work per braking	J	39.2	39.2	137	137
	Allowable total work	J	4.9 × 10 ³	4.9 × 10 ³	44.1 × 10 ³	44.1 × 10 ³
	Allowable angular acceleration	rad/s ²	30,000 max. (Speed of 2,800 r/min or more must not be changed in less than 10 ms.)			
	Brake limit	–	10 million times min.			
	Insulation class	–	Type F			

Model (R88M-)		200 VAC				
		K05030H	K10030H	K20030H	K40030H	
Item	Unit	K05030T	K10030T	K20030T	K40030T	
Rated output *1	W	50	100	200	400	
Rated torque *1	N · m	0.16	0.32	0.64	1.3	
Rated rotation speed	r/min	3,000				
Maximum rotation speed	r/min	6,000				
Momentary maximum torque *1	N · m	0.48	0.95	1.91	3.8	
Rated current *1	A (rms)	1.1	1.1	1.5	2.4	
Momentary maximum current *1	A (rms)	4.7	4.7	6.5	10.2	
Rotor inertia	Without brake	kg · m ²	0.025×10^{-4}	0.051×10^{-4}	0.14×10^{-4}	0.26×10^{-4}
	With brake	kg · m ²	0.027×10^{-4}	0.054×10^{-4}	0.16×10^{-4}	0.28×10^{-4}
Applicable load inertia	–	30 times the rotor inertia max.*2				
Torque constant *1	N · m/A	0.11±10%	0.21±10%	0.32±10%	0.40±10%	
Power rate *1	Without brake	kW/s	10.1	19.8	28.9	62.3
	With brake	kW/s	9.4	18.7	25.3	57.8
Mechanical time constant	Without brake	ms	1.43	1.07	0.58	0.43
	With brake	ms	1.54	1.13	0.66	0.46
Electrical time constant	ms	0.82	0.90	3.2	3.4	
Allowable radial load *3	N	68	68	245	245	
Allowable thrust load *3	N	58	58	98	98	
Weight	Without brake	kg	Approx. 0.31	Approx. 0.46	Approx. 0.79	Approx. 1.2
	With brake	kg	Approx. 0.51	Approx. 0.66	Approx. 1.2	Approx. 1.6
Radiator plate dimensions (material)		100 × 80 × t10 (Al)		130 × 120 × t12 (Al)		
Applicable drives (R88D-)		KN01H-ECT	KN01H-ECT	KN02H-ECT	KN04H-ECT	
Brake specifications	Brake inertia	kg · m ²	2×10^{-7}	2×10^{-7}	1.8×10^{-6}	1.8×10^{-6}
	Excitation voltage *4	V	24 VDC ± 10%			
	Power consumption (at 20°C)	W	7	7	9	9
	Current consumption (at 20°C)	A	0.3	0.3	0.36	0.36
	Static friction torque	N · m	0.29 min.	0.29 min.	1.27 min.	1.27 min.
	Attraction time *5	ms	35 max.	35 max.	50 max.	50 max.
	Release time *5	ms	20 max.	20 max.	15 max.	15 max.
	Backlash		± 1°			
	Allowable work per braking	J	39.2	39.2	137	137
	Allowable total work	J	4.9×10^3	4.9×10^3	44.1×10^3	44.1×10^3
	Allowable angular acceleration	rad/s ²	30,000 max. (Speed of 2,800 r/min or more must not be changed in less than 10 ms.)			
	Brake limit	–	10 million times min.			
	Insulation class	–	Type F			

Model (R88M-)		200 VAC			
		K75030H	K1K030H	K1K530H	
Item	Unit	K75030T	K1K030T	K1K530T	
Rated output *1	W	750	1000	1500	
Rated torque *1	N · m	2.4	3.18	4.77	
Rated rotation speed	r/min	3,000			
Maximum rotation speed	r/min	6,000	5,000		
Momentary maximum torque *1	N · m	7.1	9.55	14.3	
Rated current *1	A (rms)	4.1	6.6	8.2	
Momentary maximum current *1	A (rms)	17.4	28	35	
Rotor inertia	Without brake	kg · m ²	0.87×10^{-4}	2.03×10^{-4}	2.84×10^{-4}
	With brake	kg · m ²	0.97×10^{-4}	2.35×10^{-4}	3.17×10^{-4}
Applicable load inertia	–	20 times the rotor inertia max. *2	15 times the rotor inertia max. *2		
Torque constant *1	N · m/A	0.45±10%	0.37	0.45	
Power rate *1	Without brake	kW/s	65.4	49.8	80.1
	With brake	kW/s	58.7	43.0	71.8
Mechanical time constant	Without brake	ms	0.37	0.61	0.49
	With brake	ms	0.42	0.71	0.55
Electrical time constant	ms	5.3	5.8	6.3	
Allowable radial load *3	N	392	490	490	
Allowable thrust load *3	N	147	196	196	
Weight	Without brake	kg	Approx. 2.3	Approx. 3.5	Approx. 4.4
	With brake	kg	Approx. 3.1	Approx. 4.5	Approx. 5.4
Radiator plate dimensions (material)		170 × 160 × t12 (Al)	320 × 300 × t20 (Al)		
Applicable drives (R88D-)		KN08H-ECT	KN15H-ECT	KN15H-ECT	
Brake specifications	Brake inertia	kg · m ²	0.33×10^{-4}	0.33×10^{-4}	0.33×10^{-4}
	Excitation voltage *4	V	24 VDC ± 10%		
	Power consumption (at 20°C)	W	17	19	19
	Current consumption (at 20°C)	A	0.70±10%	0.81±10%	0.81±10%
	Static friction torque	N · m	2.5 min.	7.8 min.	7.8 min.
	Attraction time *5	ms	50 max.	50 max.	50 max.
	Release time *5	ms	15 max. *6	15 max. *6	15 max. *6
	Backlash		± 1°		
	Allowable work per braking	J	392	392	392
	Allowable total work	J	4.9×10^5	4.9×10^5	4.9×10^5
	Allowable angular acceleration	rad/s ²	10,000		
	Brake limit	–	10 million times min.		
	Insulation class	–	Type F		

3 Specifications

Model (R88M-)		200 VAC				
		K2K030H	K3K030H	K4K030H	K5K030H	
Item	Unit	K2K030T	K3K030T	K4K030T	K5K030T	
Rated output *1	W	2000	3000	4000	5000	
Rated torque *1	N · m	6.37	9.55	12.7	15.9	
Rated rotation speed	r/min	3,000				
Maximum rotation speed	r/min	5,000		4,500	4,500	
Momentary maximum torque *1	N · m	19.1	28.6	38.2	47.7	
Rated current *1	A (rms)	11.3	18.1	19.6	24.0	
Momentary maximum current *1	A (rms)	48	77	83	102	
Rotor inertia	Without brake	kg · m ²	3.68×10^{-4}	6.50×10^{-4}	12.9×10^{-4}	17.4×10^{-4}
	With brake	kg · m ²	4.01×10^{-4}	7.85×10^{-4}	14.2×10^{-4}	18.6×10^{-4}
Applicable load inertia	–	15 times the rotor inertia max. *2				
Torque constant *1	N · m/A	0.44	0.41	0.49	0.49	
Power rate *1	Without brake	kW/s	110	140	126	146
	With brake	kW/s	101	116	114	136
Mechanical time constant	Without brake	ms	0.44	0.41	0.51	0.50
	With brake	ms	0.48	0.49	0.56	0.54
Electrical time constant	ms	6.7	11	12	13	
Allowable radial load *3	N	490	490	784	784	
Allowable thrust load *3	N	196	196	343	343	
Weight	Without brake	kg	Approx. 5.3	Approx. 8.3	Approx. 11.0	Approx. 14.0
	With brake	kg	Approx. 6.3	Approx. 9.4	Approx. 12.6	Approx. 16.0
Radiator plate dimensions (material)		380 × 350 × t30 (Al)				
Applicable drives (R88D-)		KN20H-ECT	KN30H-ECT	KN50H-ECT	KN50H-ECT	
Brake specifications	Brake inertia	kg · m ²	0.33×10^{-4}	0.33×10^{-4}	1.35×10^{-4}	1.35×10^{-4}
	Excitation voltage *4	V	24 VDC ± 10%			
	Power consumption (at 20°C)	W	19	19	22	22
	Current consumption (at 20°C)	A	0.81±10%	0.81±10%	0.90±10%	0.90±10%
	Static friction torque	N · m	7.8 min.	11.8 min.	16.1 min.	16.1 min.
	Attraction time *5	ms	50 max.	80 max.	110 max.	110 max.
	Release time *5	ms	15 max. *6	15 max. *6	50 max. *7	50 max. *7
	Backlash		± 1°			
	Allowable work per braking	J	392	392	1470	1470
	Allowable total work	J	4.9×10^6	4.9×10^6	2.2×10^6	2.2×10^6
	Allowable angular acceleration	rad/s ²	10,000			
	Brake limit	–	10 million times min.			
	Rating	–	Continuous			
	Insulation class	–	Type F			

Model (R88M-)		400 VAC				
		K75030F	K1K030F	K1K530F	K2K030F	
Item	Unit	K75030C	K1K030C	K1K530C	K2K030C	
Rated output *1	W	750	1000	1500	2000	
Rated torque *1	N · m	2.39	3.18	4.77	6.37	
Rated rotation speed	r/min	3,000				
Maximum rotation speed	r/min	5,000				
Momentary maximum torque *1	N · m	7.16	9.55	14.3	19.1	
Rated current *1	A (rms)	2.4	3.3	4.2	5.7	
Momentary maximum current *1	A (rms)	10	14	18	24	
Rotor inertia	Without brake	kg · m ²	1.61×10^{-4}	2.03×10^{-4}	2.84×10^{-4}	3.68×10^{-4}
	With brake	kg · m ²	1.93×10^{-4}	2.35×10^{-4}	3.17×10^{-4}	4.01×10^{-4}
Applicable load inertia	–	20 times the rotor inertia max. *2	15 times the rotor inertia max. *2			
Torque constant *1	N · m/A	0.78	0.75	0.89	0.87	
Power rate *1	Without brake	kW/s	35.5	49.8	80.1	110
	With brake	kW/s	29.6	43	71.8	101
Mechanical time constant	Without brake	ms	0.67	0.60	0.49	0.45
	With brake	ms	0.8	0.70	0.55	0.49
Electrical time constant	ms	5.9	5.8	6.5	6.6	
Allowable radial load *3	N	490	490	490	490	
Allowable thrust load *3	N	196	196	196	196	
Weight	Without brake	kg	Approx. 3.1	Approx. 3.5	Approx. 4.4	Approx. 5.3
	With brake	kg	Approx. 4.1	Approx. 4.5	Approx. 5.4	Approx. 6.3
Radiator plate dimensions (material)		320 × 300 × t20 (Al)				
Applicable Servo Drives (R88D-)		KN10F-ECT	KN15F-ECT	KN15F-ECT	KN20F-ECT	
Brake specifications	Brake inertia	kg · m ²	0.33×10^{-4}	0.33×10^{-4}	0.33×10^{-4}	0.33×10^{-4}
	Excitation voltage *4	V	24 VDC ± 10%			
	Power consumption (at 20°C)	W	17	19	19	19
	Current consumption (at 20°C)	A	0.70±10%	0.81±10%	0.81±10%	0.81±10%
	Static friction torque	N · m	2.5 min.	7.8 min.	7.8 min.	7.8 min.
	Attraction time *5	ms	50 max.	50 max.	50 max.	50 max.
	Release time *5	ms	15 max. *6	15 max. *6	15 max. *6	15 max. *6
	Backlash		± 1°			
	Allowable work per braking	J	392	392	392	392
	Allowable total work	J	4.9×10^5	4.9×10^5	4.9×10^5	4.9×10^5
	Allowable angular acceleration	rad/s ²	10,000			
	Brake limit	–	10 million times min.			
	Rating	–	Continuous			
	Insulation class	–	Type F			

Model (R88M-)		400 VAC			
		K3K030F	K4K030F	K5K030F	
Item	Unit	K3K030C	K4K030C	K5K030C	
Rated output *1	W	3000	4000	5000	
Rated torque *1	N · m	9.55	12.7	15.9	
Rated rotation speed	r/min	3,000			
Maximum rotation speed	r/min	5,000	4,500		
Momentary maximum torque *1	N · m	28.6	38.2	47.7	
Rated current *1	A (rms)	9.2	9.9	12.0	
Momentary maximum current *1	A (rms)	39	42	51	
Rotor inertia	Without brake	kg · m ²	6.50 × 10 ⁻⁴	12.9 × 10 ⁻⁴	17.4 × 10 ⁻⁴
	With brake	kg · m ²	7.85 × 10 ⁻⁴	14.2 × 10 ⁻⁴	18.6 × 10 ⁻⁴
Applicable load inertia	–	15 times the rotor inertia max. *2			
Torque constant *1	N · m/A	0.81	0.98	0.98	
Power rate *1	Without brake	kW/s	140	126	146
	With brake	kW/s	116	114	136
Mechanical time constant	Without brake	ms	0.40	0.51	0.50
	With brake	ms	0.49	0.56	0.54
Electrical time constant	ms	12	13	13	
Allowable radial load *3	N	490	784	784	
Allowable thrust load *3	N	196	343	343	
Weight	Without brake	kg	Approx. 8.3	Approx. 11.0	Approx. 14.0
	With brake	kg	Approx. 9.4	Approx. 12.6	Approx. 16.0
Radiator plate dimensions (material)		380 × 350 × t30 (Al)			
Applicable Servo Drives (R88D-)		KN30F-ECT	KN50F-ECT	KN50F-ECT	
Brake specifications	Brake inertia	kg · m ²	0.33 × 10 ⁻⁴	0.33 × 10 ⁻⁴	1.35 × 10 ⁻⁴
	Excitation voltage *4	V	24 VDC ± 10%		
	Power consumption (at 20°C)	W	19	22	22
	Current consumption (at 20°C)	A	0.81±10%	0.90±10%	0.90±10%
	Static friction torque	N · m	11.8 min.	16.1 min.	16.1 min.
	Attraction time *5	ms	80 max.	110 max.	110 max.
	Release time *5	ms	15 max. *6	50 max. *7	50 max. *7
	Backlash		± 1°		
	Allowable work per braking	J	392	1470	1470
	Allowable total work	J	4.9 × 10 ⁵	2.2 × 10 ⁶	2.2 × 10 ⁶
	Allowable angular acceleration	rad/s ²	10,000		
	Brake limit	–	10 million times min.		
	Rating	–	Continuous		
	Insulation class	–	Type F		

- *1 These are the values when the motor is combined with a drive at normal temperature (20°C, 65%). The momentary maximum torque indicates the standard value.
- *2 Applicable load inertia.
 - The operable load inertia ratio (load inertia/rotor inertia) depends on the mechanical configuration and its rigidity. For a machine with high rigidity, operation is possible even with high load inertia. Select an appropriate motor and confirm that operation is possible.
 - The dynamic brake is intended for emergency stop and therefore has a short-time rating. If the dynamic brake is activated, allow it to be in a stop state for 3 minutes or more to prevent a circuit failure and burning of the Dynamic Brake Resistor.
- *3 The allowable radial and thrust loads are the values determined for a limit of 20,000 hours at normal operating temperatures. The allowable radial loads are applied as shown in the following diagram.

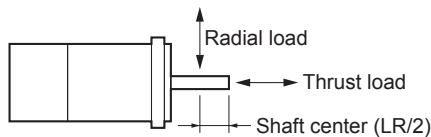

- *4 This is a non-excitation brake. (It is released when excitation voltage is applied.)
- *5 The operation time is the value (reference value) measured with a surge suppressor (CR50500 by Okaya Electric Industries Co., Ltd.).
- *6 Direct current switching with a varistor (Z15D151 by Ishizuka Electronics Co.).
- *7 Direct current switching with a varistor (TNR9G820K by Nippon Chemi-Con Corporation).

● Torque-Rotation Speed Characteristics for 3,000-r/min Servomotors

- 3,000-r/min Servomotors (100 VAC)

The following graphs show the characteristics with a 3-m standard cable and a 100-VAC input.

• R88M-K05030H/T (50 W)

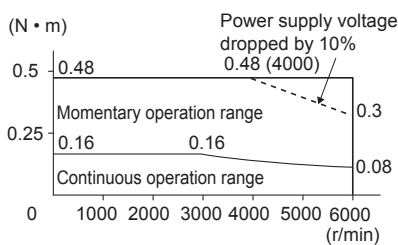

• R88M-K10030L/S (100 W)

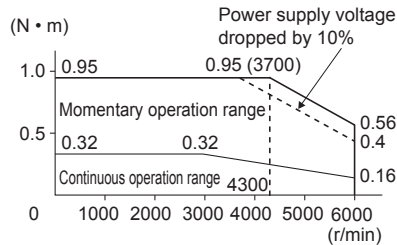

• R88M-K20030L/S (200 W)

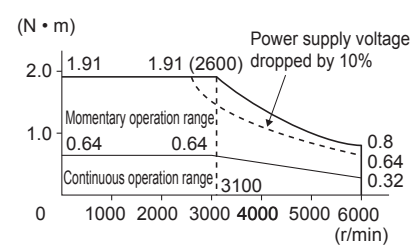

• R88M-K40030L/S (400 W)

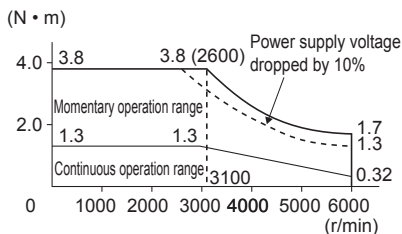

Note 1 The continuous operation range is the range in which continuous operation is possible. Continuous operation at the maximum speed is also possible. However, doing so will reduce the output torque.

- 2 If the motor power cable exceeds 20 m, the voltage drop will increase and the momentary operation range will become narrower.

3 Specifications

- 3,000-r/min Servomotors (200 VAC)

The following graphs show the characteristics with a 3-m standard cable and a 200-VAC input.

- R88M-K05030H/T (50 W)

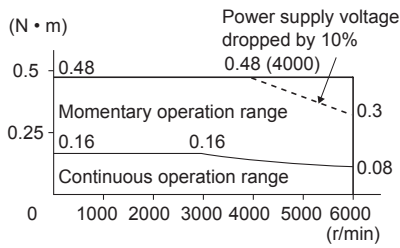

- R88M-K10030H/T (100 W)

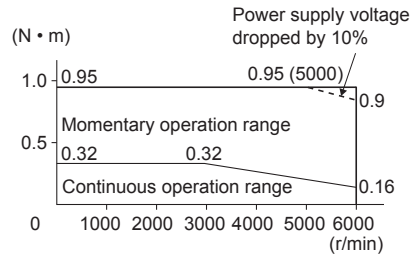

- R88M-K20030H/T (200 W)

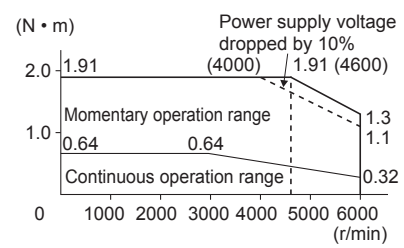

- R88M-K40030H/T (400 W)

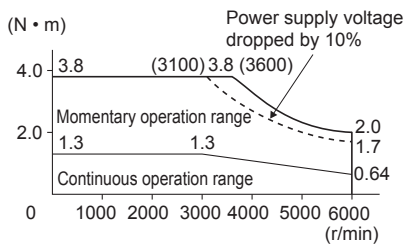

- R88M-K75030H/T (750 W)

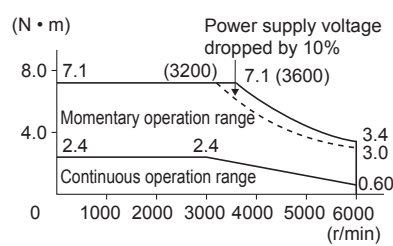

- R88M-K1K030H/T (1 kW)

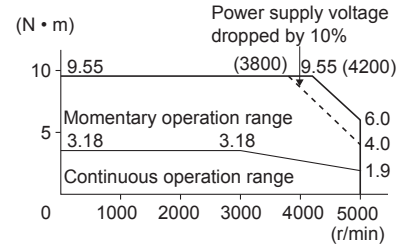

- R88M-K1K530H/T (1.5 kW)

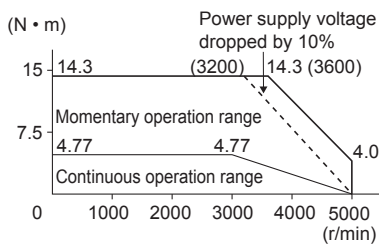

- R88M-K2K030H/T (2 kW)

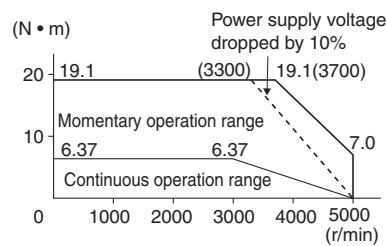

- R88M-K3K030H/T (3 kW)

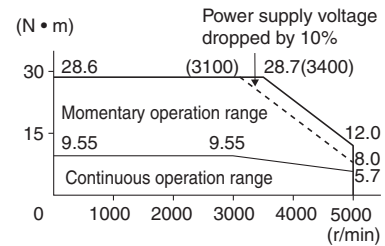

- R88M-K4K030H/T (4 kW)

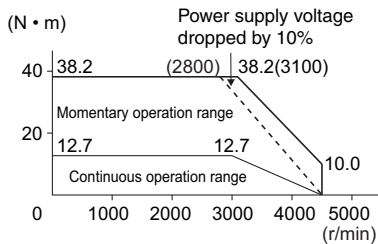

- R88M-K5K030H/T (5 kW)

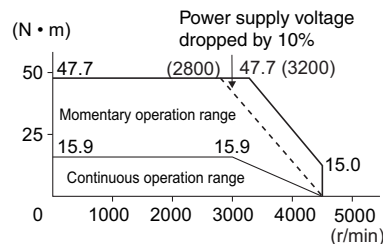

Note 1 The continuous operation range is the range in which continuous operation is possible. Continuous operation at the maximum speed is also possible. However, doing so will reduce the output torque.

2 If the motor power cable exceeds 20 m, the voltage drop will increase and the momentary operation range will become narrower.

• 3,000-r/min Servomotors (400 VAC)

The following graphs show the characteristics with a 3-m standard cable and a 400-VAC input.

• R88M-K75030F/C (750 W)

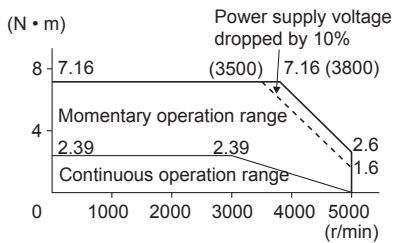

• R88M-K1K030F/C (1 kW)

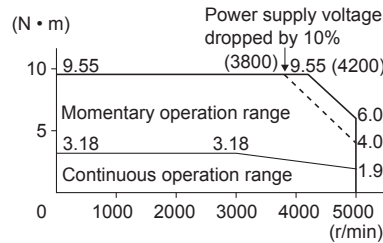

• R88M-K1K530F/C (1.5 kW)

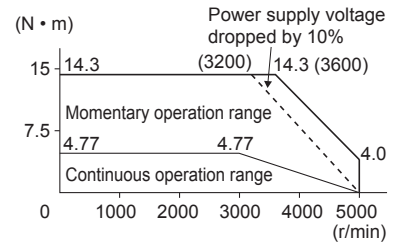

• R88M-K2K030F/C (2 kW)

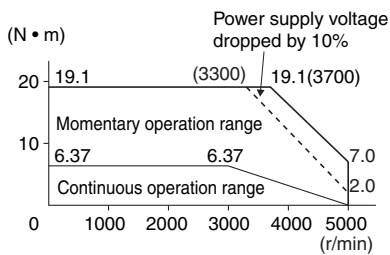

• R88M-K3K030F/C (3 kW)

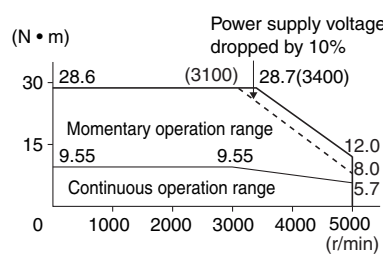

• R88M-K4K030F/C (4 kW)

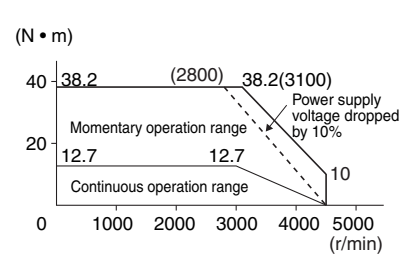

• R88M-K5K030F/C (5 kW)

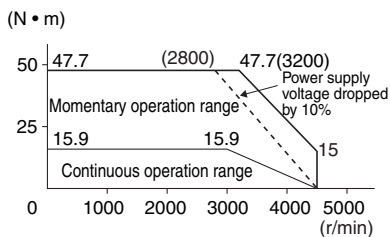

Note 1 The continuous operation range is the range in which continuous operation is possible. Continuous operation at the maximum speed is also possible. However, doing so will reduce the output torque.

2 If the motor power cable exceeds 20 m, the voltage drop will increase and the momentary operation range will become narrower.



Precautions for Correct Use

Use the following Servomotors in the ranges shown in the graphs below. Usage outside of these ranges may cause the motor to generate heat, which could result in encoder malfunction.

- R88M-K05030L/S/H/T
(50 W: With oil seal)

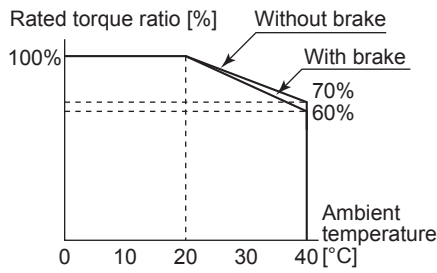

- R88M-K10030L/S/H/T
(100 W: With oil seal)

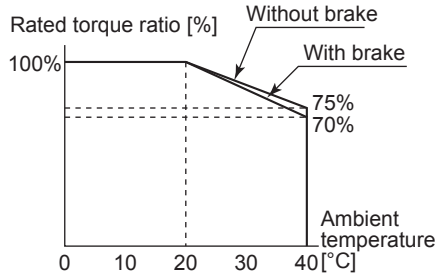

- R88M-K20030L/S/H/T
(200 W: With oil seal)

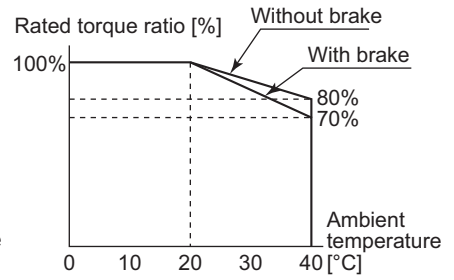

- R88M-K40030L/S/H/T
(400 W: Without oil seal)

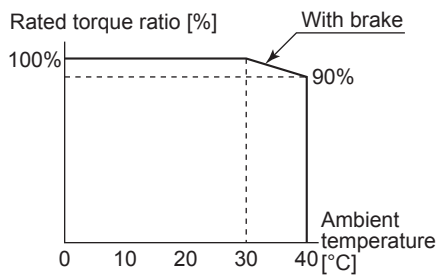

- R88M-K40030L/S/H/T
(400 W: With oil seal)

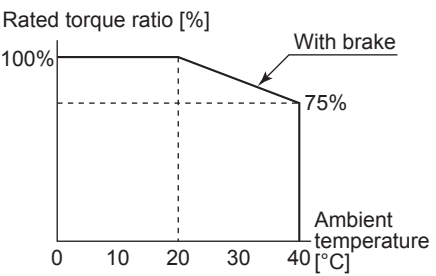

- R88M-K1K530H/T/F/C
(1.5 kW)

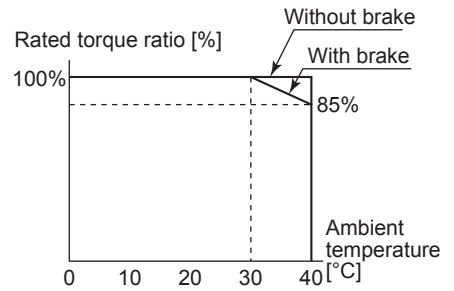

- R88M-K2K030H/T/F/C (2 kW)

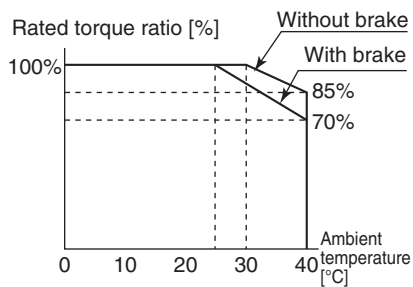

- R88M-K3K030H/T/F/C (3 kW)

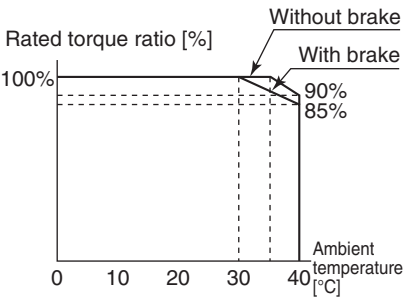

- R88M-K4K030H/T/F/C (4 kW)

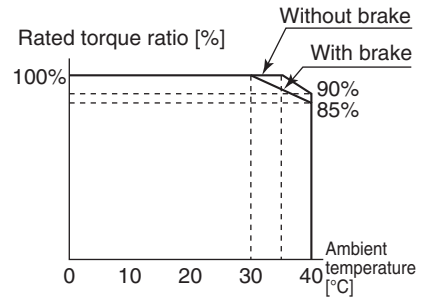

- R88M-K5K030H/T/F/C (5 kW)

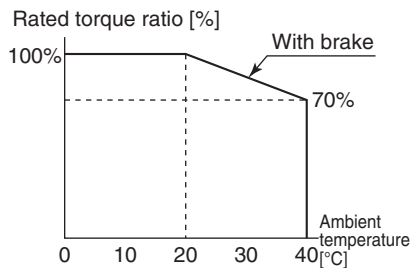

1,500-r/min, 2,000-r/min Servomotors

Model (R88M-)		200 VAC			
		K1K020H	K1K520H	K2K020H	
Item	Unit	K1K020T	K1K520T	K2K020T	
Rated output *1	W	1,000	1,500	2,000	
Rated torque *1	N · m	4.77	7.16	9.55	
Rated rotation speed	r/min	2,000			
Maximum rotation speed	r/min	3,000			
Momentary maximum torque *1	N · m	14.3	21.5	28.6	
Rated current *1	A (rms)	5.7	9.4	11.5	
Momentary maximum current *1	A (rms)	24	40	49	
Rotor inertia	Without brake	kg · m ²	4.60 × 10 ⁻⁴	6.70 × 10 ⁻⁴	8.72 × 10 ⁻⁴
	With brake	kg · m ²	5.90 × 10 ⁻⁴	7.99 × 10 ⁻⁴	10.0 × 10 ⁻⁴
Applicable load inertia	–	10 times the rotor inertia max. *2			
Torque constant *1	N · m/A	0.63	0.58	0.64	
Power rate *1	Without brake	kW/s	49.5	76.5	105
	With brake	kW/s	38.6	64.2	91.2
Mechanical time constant	Without brake	ms	0.80	0.66	0.66
	With brake	ms	1.02	0.80	0.76
Electrical time constant	ms	9.4	10	10	
Allowable radial load *3	N	490	490	490	
Allowable thrust load *3	N	196	196	196	
Weight	Without brake	kg	Approx. 5.2	Approx. 6.7	Approx. 8.0
	With brake	kg	Approx. 6.7	Approx. 8.2	Approx. 9.5
Radiator plate dimensions (material)		275 × 260 × t15 (Al)			
Applicable Servo Drives (R88D-)		KN10H-ECT	KN15H-ECT	KN20H-ECT	
Brake specifications	Brake inertia	kg · m ²	1.35 × 10 ⁻⁴	1.35 × 10 ⁻⁴	1.35 × 10 ⁻⁴
	Excitation voltage *4	V	24 VDC ± 10%		
	Power consumption (at 20°C)	W	14	19	19
	Current consumption (at 20°C)	A	0.59±10%	0.79±10%	0.79±10%
	Static friction torque	N · m	4.9 min.	13.7 min.	13.7 min.
	Attraction time *5	ms	80 max.	100 max.	100 max.
	Release time *5	ms	70 max. *6	50 max. *6	50 max. *6
	Backlash		± 1°		
	Allowable work per braking	J	588	1176	1176
	Allowable total work	J	7.8 × 10 ⁵	1.5 × 10 ⁶	1.5 × 10 ⁶
	Allowable angular acceleration	rad/s ²	10,000		
	Brake limit	–	10 million times min.		
	Rating	–	Continuous		
	Insulation class	–	Type F		

Model (R88M-)		200 VAC						
		K3K020H	K4K020H	K5K020H	–	–	–	
Item	Unit	K3K020T	K4K020T	K5K020T	K7K515T	K11K015T	K15K015T	
Rated output *1	W	3,000	4,000	5,000	7,500	11,000	15,000	
Rated torque *1	N · m	14.3	19.1	23.9	47.8	70.0	95.5	
Rated rotation speed	r/min	2,000			1,500			
Maximum rotation speed	r/min	3,000				2000		
Momentary maximum torque *1	N · m	43.0	57.3	71.6	119.0	175.0	224.0	
Rated current *1	A (rms)	17.4	21.0	25.9	44.0	54.2	66.1	
Momentary maximum current *1	A (rms)	74	89	110	165	203	236	
Rotor inertia	Without brake	kg · m ²	12.9 × 10 ⁻⁴	37.6 × 10 ⁻⁴	48.0 × 10 ⁻⁴	101 × 10 ⁻⁴	212 × 10 ⁻⁴	302 × 10 ⁻⁴
	With brake	kg · m ²	14.2 × 10 ⁻⁴	38.6 × 10 ⁻⁴	48.8 × 10 ⁻⁴	107 × 10 ⁻⁴	220 × 10 ⁻⁴	311 × 10 ⁻⁴
Applicable load inertia	–	10 times the rotor inertia max. *2			10 times the rotor inertia max. *2			
Torque constant *1	N · m/A	0.59	0.70	0.70	0.77	0.92	1.05	
Power rate *1	Without brake	kW/s	159	97.1	119	226	231	302
	With brake	kW/s	144	94.5	117	213	223	293
Mechanical time constant	Without brake	ms	0.57	0.65	0.63	0.58	0.80	0.71
	With brake	ms	0.63	0.66	0.64	0.61	0.83	0.74
Electrical time constant	ms	12	20	19	21	31	32	
Allowable radial load *3	N	784	784	784	1176	2254	2254	
Allowable thrust load *3	N	343	343	343	490	686	686	
Weight	Without brake	kg	Approx. 11.0	Approx. 15.5	Approx. 18.6	Approx. 36.4	Approx. 52.7	Approx. 70.2
	With brake	kg	Approx. 12.6	Approx. 18.7	Approx. 21.8	Approx. 40.4	Approx. 58.9	Approx. 76.3
Radiator plate dimensions (material)		380 × 350 × t30 (Al)	470 × 440 × t30 (Al)		550 × 520 × t30 (Al)	670 × 630 × t35 (Al)		
Applicable Servo Drives (R88D-)		KN30H-ECT	KN50H-ECT	KN50H-ECT	KN75H-ECT	KN150H-ECT	KN150H-ECT	
Brake specifications	Brake inertia	kg · m ²	1.35 × 10 ⁻⁴	4.7 × 10 ⁻⁴	4.7 × 10 ⁻⁴	4.7 × 10 ⁻⁴	7.1 × 10 ⁻⁴	7.1 × 10 ⁻⁴
	Excitation voltage *4	V	24 VDC ± 10%					
	Power consumption (at 20°C)	W	22	31	31	34	26	26
	Current consumption (at 20°C)	A	0.90±10%	1.3±10%	1.3±10%	1.4±10%	1.08±10%	1.08±10%
	Static friction torque	N · m	16.2 min.	24.5 min.	24.5 min.	58.8 min.	100 min.	100 min.
	Attraction time *5	ms	110 max.	80 max.	80 max.	150 max.	300 max.	300 max.
	Release time *5	ms	50 max. *6	25 max. *7	25 max. *7	50 max.	140 max.	140 max.
	Backlash		± 1°					
	Allowable work per braking	J	1470	1372	1372	1372	2000	2000
	Allowable total work	J	2.2 × 10 ⁶	2.9 × 10 ⁶	2.9 × 10 ⁶	2.9 × 10 ⁶	4.0 × 10 ⁶	4.0 × 10 ⁶
	Allowable angular acceleration	rad/s ²	10,000			5,000	3,000	
	Brake limit	–	10 million times min.					
	Rating	–	Continuous					
Insulation class	–	Type F						

Model (R88M-)		400 VAC				
		K40020F	K60020F	K1K020F	K1K520F	
Item	Unit	K40020C	K60020C	K1K020C	K1K520C	
Rated output *1	W	400	600	1,000	1,500	
Rated torque *1	N · m	1.91	2.86	4.77	7.16	
Rated rotation speed	r/min	2,000				
Maximum rotation speed	r/min	3,000				
Momentary maximum torque *1	N · m	5.73	8.59	14.3	21.5	
Rated current *1	A (rms)	1.2	1.5	2.8	4.7	
Momentary maximum current *1	A (rms)	4.9	6.5	12	20	
Rotor inertia	Without brake	kg · m ²	1.61×10^{-4}	2.03×10^{-4}	4.60×10^{-4}	6.70×10^{-4}
	With brake	kg · m ²	1.90×10^{-4}	2.35×10^{-4}	5.90×10^{-4}	7.99×10^{-4}
Applicable load inertia	–	10 times the rotor inertia max. *2				
Torque constant *1	N · m/A	1.27	1.38	1.27	1.16	
Power rate *1	Without brake	kW/s	22.7	40.3	49.5	76.5
	With brake	kW/s	19.2	34.8	38.6	64.2
Mechanical time constant	Without brake	ms	0.70	0.62	0.79	0.66
	With brake	ms	0.83	0.72	1.01	0.79
Electrical time constant	ms	5.7	5.9	10	10	
Allowable radial load *3	N	490	490	490	490	
Allowable thrust load *3	N	196	196	196	196	
Weight	Without brake	kg	Approx. 3.1	Approx. 3.5	Approx. 5.2	Approx. 6.7
	With brake	kg	Approx. 4.1	Approx. 4.5	Approx. 6.7	Approx. 8.2
Radiator plate dimensions (material)		320 × 300 × t20 (Al)		275 × 260 × t15 (Al)		
Applicable drives (R88D-)		KN06F-ECT	KN06F-ECT	KN10F-ECT	KN15F-ECT	
Brake specifications	Brake inertia	kg · m ²	1.35×10^{-4}	1.35×10^{-4}	1.35×10^{-4}	1.35×10^{-4}
	Excitation voltage *4	V	24 VDC ± 10%			
	Power consumption (at 20°C)	W	17	17	14	19
	Current consumption (at 20°C)	A	0.70±10%	0.70±10%	0.59±10%	0.79±10%
	Static friction torque	N · m	2.5 min.	2.5 min.	4.9 min.	13.7 min.
	Attraction time *5	ms	50 max.	50 max.	80 max.	100 max.
	Release time *5	ms	15 max. *7	15 max. *7	70 max. *6	50 max. *6
	Backlash		± 1°			
	Allowable work per braking	J	392	392	588	1176
	Allowable total work	J	4.9×10^5	4.9×10^5	7.8×10^5	1.5×10^6
	Allowable angular acceleration	rad/s ²	10,000			
	Brake limit	–	10 million times min.			
	Rating	–	Continuous			
	Insulation class	–	Type F			

Model (R88M-)		400 VAC				
		K2K020F	K3K020F	K4K020F	K5K020F	
Item	Unit	K2K020C	K3K020C	K4K020C	K5K020C	
Rated output *1	W	2,000	3,000	4,000	5,000	
Rated torque *1	N · m	9.55	14.3	19.1	23.9	
Rated rotation speed	r/min	2,000				
Maximum rotation speed	r/min	3,000				
Momentary maximum torque *1	N · m	28.7	43.0	57.3	71.6	
Rated current *1	A (rms)	5.9	8.7	10.6	13.0	
Momentary maximum current *1	A (rms)	25	37	45	55	
Rotor inertia	Without brake	kg · m ²	8.72 × 10 ⁻⁴	12.9 × 10 ⁻⁴	37.6 × 10 ⁻⁴	48.0 × 10 ⁻⁴
	With brake	kg · m ²	10.0 × 10 ⁻⁴	14.2 × 10 ⁻⁴	38.6 × 10 ⁻⁴	48.8 × 10 ⁻⁴
Applicable load inertia	–	10 times the rotor inertia max. *2				
Torque constant *1	N · m/A	1.27	1.18	1.40	1.46	
Power rate *1	Without brake	kW/s	105	159	97.1	119
	With brake	kW/s	91.2	144	94.5	117
Mechanical time constant	Without brake	ms	0.68	0.56	0.60	0.60
	With brake	ms	0.78	0.61	0.61	0.61
Electrical time constant	ms	10	12	21	19	
Allowable radial load *3	N	490	784	784	784	
Allowable thrust load *3	N	196	343	343	343	
Weight	Without brake	kg	Approx. 8.0	Approx. 11.0	Approx. 15.5	Approx. 18.6
	With brake	kg	Approx. 9.5	Approx. 12.6	Approx. 18.7	Approx. 21.8
Radiator plate dimensions	(material)	275 × 260 × t15 (Al)	380 × 350 × t30 (Al)	470 × 440 × t30 (Al)		
Applicable Servo Drives (R88D-)		KN20F-ECT	KN30F-ECT	KN50F-ECT	KN50F-ECT	
Brake specifications	Brake inertia	kg · m ²	1.35 × 10 ⁻⁴	1.35 × 10 ⁻⁴	4.7 × 10 ⁻⁴	4.7 × 10 ⁻⁴
	Excitation voltage *4	V	24 VDC ± 10%			
	Power consumption (at 20°C)	W	19	22	31	31
	Current consumption (at 20°C)	A	0.79±10%	0.90±10%	1.3±10%	1.3±10%
	Static friction torque	N · m	13.7 min.	16.2 min.	24.5 min.	24.5 min.
	Attraction time *5	ms	100 max.	110 max.	80 max.	80 max.
	Release time *5	ms	50 max. *6	50 max. *6	25 max. *7	25 max. *7
	Backlash		± 1°			
	Allowable work per braking	J	1176	1470	1372	1372
	Allowable total work	J	1.5 × 10 ⁶	2.2 × 10 ⁶	2.9 × 10 ⁶	2.9 × 10 ⁶
	Allowable angular acceleration	rad/s ²	10,000			
	Brake limit	–	10 million times min.			
	Rating	–	Continuous			
	Insulation class	–	Type F			

Model (R88M-)		400 VAC			
		–	–	–	
Item	Unit	K7K515C	K11K015C	K15K015C	
Rated output *1	W	7,500	11,000	15,000	
Rated torque *1	N · m	47.8	70.0	95.5	
Rated rotation speed	r/min	1,500			
Maximum rotation speed	r/min	3,000	2,000		
Momentary maximum torque *1	N · m	119.0	175.0	224.0	
Rated current *1	A (rms)	22.0	27.1	33.1	
Momentary maximum current *1	A (rms)	83	101	118	
Rotor inertia	Without brake	kg · m ²	101 × 10 ⁻⁴	212 × 10 ⁻⁴	302 × 10 ⁻⁴
	With brake	kg · m ²	107 × 10 ⁻⁴	220 × 10 ⁻⁴	311 × 10 ⁻⁴
Applicable load inertia	–	10 times the rotor inertia max. *2			
Torque constant *1	N · m/A	1.54	1.84	2.10	
Power rate *1	Without brake	kW/s	226	231	302
	With brake	kW/s	213	223	293
Mechanical time constant	Without brake	ms	0.58	0.80	0.71
	With brake	ms	0.61	0.83	0.74
Electrical time constant	ms	21	31	32	
Allowable radial load *3	N	1,176	2,254	2,254	
Allowable thrust load *3	N	490	686	686	
Weight	Without brake	kg	Approx. 36.4	Approx. 52.7	Approx. 70.2
	With brake	kg	Approx. 40.4	Approx. 58.9	Approx. 76.3
Radiator plate dimensions (material)		550 × 520 × t30 (Al)	670 × 630 × t35 (Al)		
Applicable Servo Drives (R88D-)		KN75F-ECT	KN150F-ECT	KN150F-ECT	
Brake specifications	Brake inertia	kg · m ²	4.7 × 10 ⁻⁴	7.1 × 10 ⁻⁴	7.1 × 10 ⁻⁴
	Excitation voltage *4	V	24 VDC ± 10%		
	Power consumption (at 20°C)	W	34	26	26
	Current consumption (at 20°C)	A	1.4±10%	1.08±10%	1.08±10%
	Static friction torque	N · m	58.8 min.	100 min.	100 min.
	Attraction time *5	ms	150 max.	300 max.	300 max.
	Release time *5	ms	50 max.	140 max.	140 max.
	Backlash		± 1°		
	Allowable work per braking	J	1372	2000	2000
	Allowable total work	J	2.9 × 10 ⁶	4.0 × 10 ⁶	4.0 × 10 ⁶
	Allowable angular acceleration	rad/s ²	5,000	3,000	
	Brake limit	–	10 million times min.		
	Rating	–	Continuous		
	Insulation class	–	Type F		

- *1 These are the values when the motor is combined with a drive at normal temperature (20°C, 65%). The momentary maximum torque indicates the standard value.
- *2 Applicable load inertia.
 - The operable load inertia ratio (load inertia/rotor inertia) depends on the mechanical configuration and its rigidity. For a machine with high rigidity, operation is possible even with high load inertia. Select an appropriate motor and confirm that operation is possible.
 - The dynamic brake is intended for emergency stop and therefore has a short-time rating. If the dynamic brake is activated, allow it to be in a stop state for 3 minutes or more to prevent a circuit failure and burning of the Dynamic Brake Resistor.
- *3 The allowable radial and thrust loads are the values determined for a limit of 20,000 hours at normal operating temperatures. The allowable radial loads are applied as shown in the following diagram.

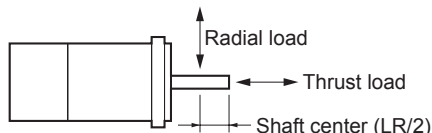

- *4 This is a non-excitation brake. (It is released when excitation voltage is applied.)
- *5 The operation time is the value (reference value) measured with a surge suppressor (CR50500 by Okaya Electric Industries Co., Ltd.).
- *6 Direct current switching with a varistor (TNR9G820K by Nippon Chemi-Con Corporation).
- *7 Direct current switching with a varistor (Z15D151 by Ishizuka Electronics Co.).

● Torque-Rotation Speed Characteristics for 1,500-r/min and 2,000-r/min Motors

- 1,500-r/min and 2,000-r/min Servomotors (200 VAC)
- The following graphs show the characteristics with a 3-m standard cable and a 200-VAC input.

• R88M-K1K020H/T (1 kW)

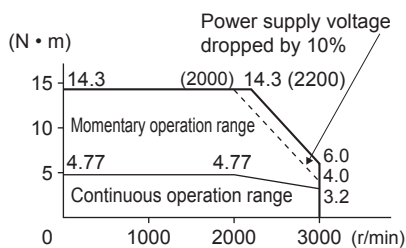

• R88M-K1K520H/T (1.5 kW)

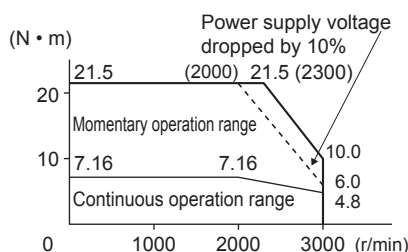

• R88M-K2K020H/T (2 kW)

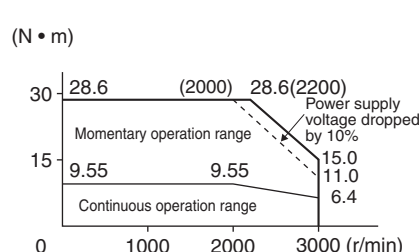

• R88M-K3K020H/T (3 kW)

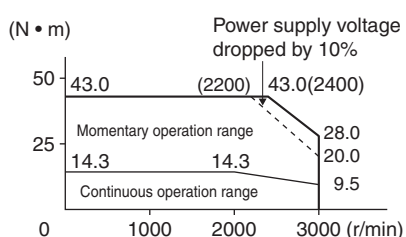

• R88M-K4K020H/T (4 kW)

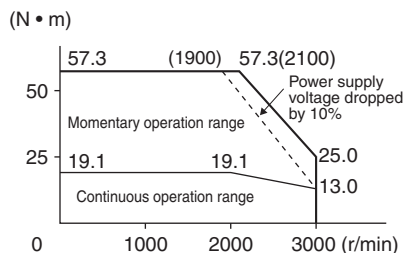

• R88M-K5K020H/T (5 kW)

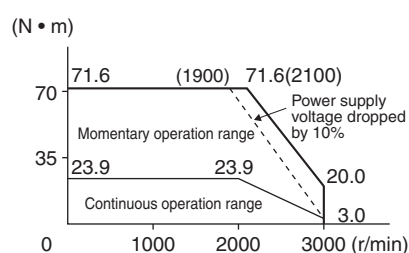

• R88M-K7K515T (7.5 kW)

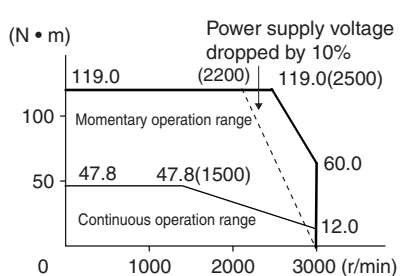

• R88M-K11K015T (11 kW)

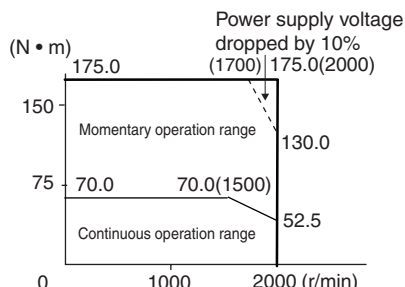

• R88M-K15K015T (15 kW)

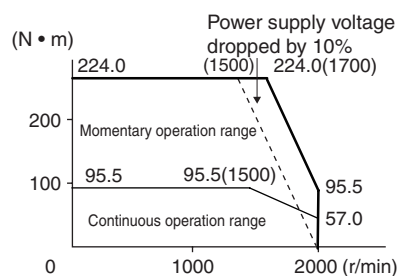

Note 1 The continuous operation range is the range in which continuous operation is possible. Continuous operation at the maximum speed is also possible. However, doing so will reduce the output torque.

2 If the motor power cable exceeds 20 m, the voltage drop will increase and the momentary operation range will become narrower.

• 1,500-r/min and 2,000-r/min Servomotors (400 VAC)

The following graphs show the characteristics with a 3-m standard cable and a 400-VAC input.

• R88M-K40020F/C (400 W)

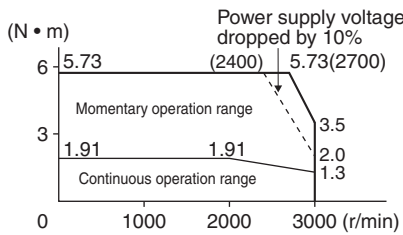

• R88M-K60020F/C (600 W)

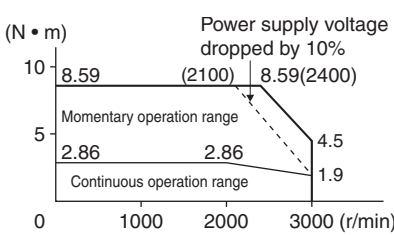

• R88M-K1K020F/C (1 kW)

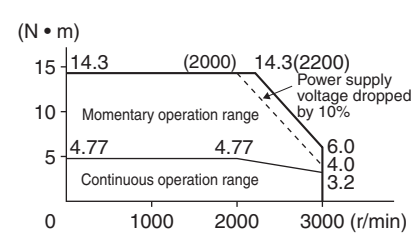

• R88M-K1K520F/C (1.5 kW)

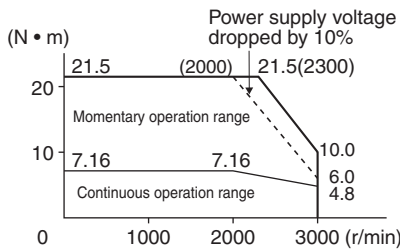

• R88M-K2K020F/C (2 kW)

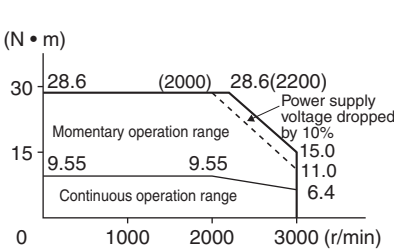

• R88M-K3K020F/C (3 kW)

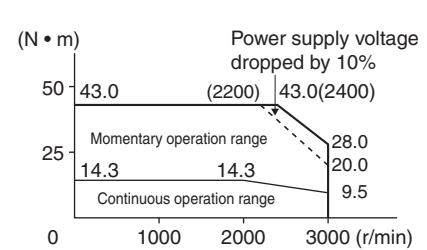

• R88M-K4K020F/C (4 kW)

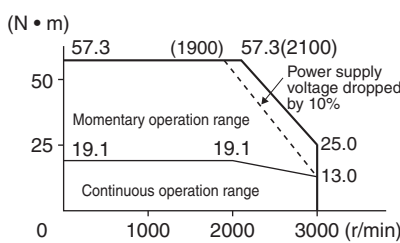

• R88M-K5K020F/C (5 kW)

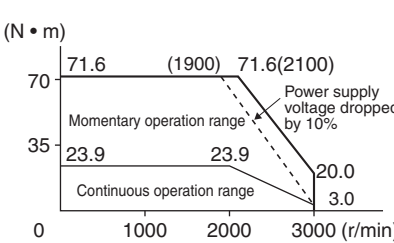

• R88M-K7K515C (7.5 kW)

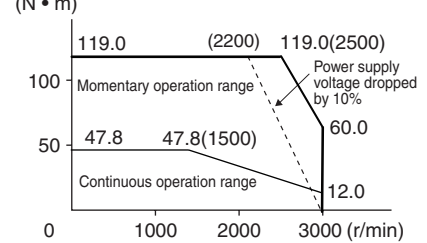

• R88M-K11K015C (11 kW)

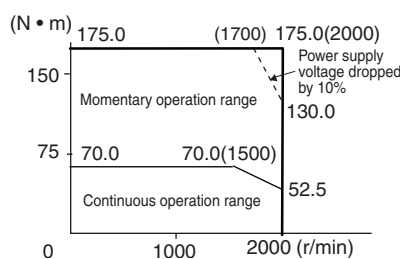

• R88M-K15K015C (15 kW)

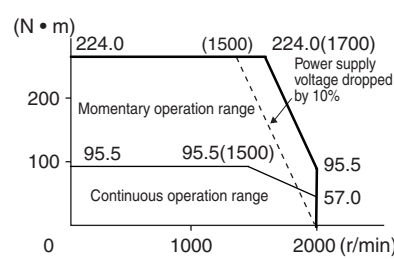

Note 1 The continuous operation range is the range in which continuous operation is possible. Continuous operation at the maximum speed is also possible. However, doing so will reduce the output torque.

2 If the motor power cable exceeds 20 m, the voltage drop will increase and the momentary operation range will become narrower.

Use the following Servomotors in the ranges shown in the graphs below. Using outside of these ranges may cause the motor to generate heat, which could result in encoder malfunction.

- R88M-K5K020H/T/F/C (5 kW)

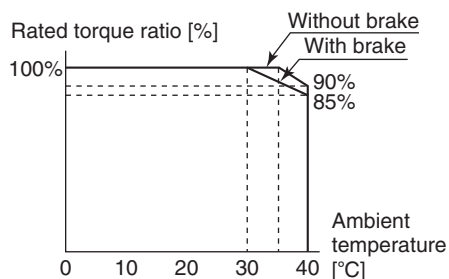

- R88M-K7K515T/C (7.5 kW)

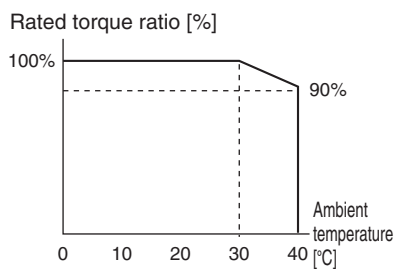

- R88M-K15K015T/C (15 kW)

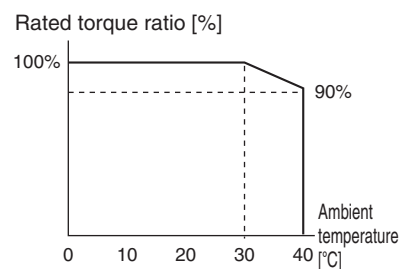

1,000-r/min Servomotors

Model (R88M-)			200 VAC				
			K90010H	K2K010H	K3K010H	–	–
Item	Unit	K90010T	K2K010T	K3K010T	K4K510T	K6K010T	
Rated output *1	W	900	2,000	3,000	4,500	6,000	
Rated torque *1	N · m	8.59	19.1	28.7	43.0	57.3	
Rated rotation speed	r/min	1,000					
Maximum rotation speed	r/min	2,000					
Momentary maximum torque *1	N · m	19.3	47.7	71.7	107.0	143.0	
Rated current *1	A (rms)	7.6	17.0	22.6	29.7	38.8	
Momentary maximum current *1	A (rms)	24	60	80	110	149	
Rotor inertia	Without brake	kg · m ²	6.70 × 10 ⁻⁴	30.3 × 10 ⁻⁴	48.4 × 10 ⁻⁴	79.1 × 10 ⁻⁴	101 × 10 ⁻⁴
	With brake	kg · m ²	7.99 × 10 ⁻⁴	31.4 × 10 ⁻⁴	49.2 × 10 ⁻⁴	84.4 × 10 ⁻⁴	107 × 10 ⁻⁴
Applicable load inertia	–	10 times the rotor inertia max. *2					
Torque constant *1	N · m/A	0.86	0.88	0.96	1.02	1.04	
Power rate *1	Without brake	kW/s	110	120	170	233	325
	With brake	kW/s	92.4	116	167	219	307
Mechanical time constant	Without brake	ms	0.66	0.75	0.63	0.55	0.54
	With brake	ms	0.78	0.78	0.64	0.63	0.57
Electrical time constant	ms	11	18	21	20	23	
Allowable radial load *3	N	686	1176	1470	1470	1764	
Allowable thrust load *3	N	196	490	490	490	588	
Weight	Without brake	kg	Approx. 6.7	Approx. 14.0	Approx. 20.0	Approx. 29.4	Approx. 36.4
	With brake	kg	Approx. 8.2	Approx. 17.5	Approx. 23.5	Approx. 33.3	Approx. 40.4
Radiator plate dimensions (material)		270 × 260 × t15 (Al)			470 × 440 × t30 (Al)	550 × 520 × t30 (Al)	
Applicable Servo Drives (R88D-)		KN15H-ECT	KN30H-ECT	KN50H-ECT	KN50H-ECT	KN75H-ECT	
Brake specifications	Brake inertia	kg · m ²	1.35 × 10 ⁻⁴	4.7 × 10 ⁻⁴	4.7 × 10 ⁻⁴	4.7 × 10 ⁻⁴	4.7 × 10 ⁻⁴
	Excitation voltage *4	V	24 VDC ± 10%				
	Power consumption (at 20°C)	W	19	31	34	34	34
	Current consumption (at 20°C)	A	0.79±10%	1.3±10%	1.4±10%	1.4±10%	1.4±10%
	Static friction torque	N · m	13.7 min.	24.5 min.	58.8 min.	58.8 min.	58.8 min.
	Attraction time *5	ms	100 max.	80 max.	150 max.	150 max.	150 max.
	Release time *5	ms	50 max. *6	25 max. *7	50 max. *7	50 max.	50 max.
	Backlash		± 1°				
	Allowable work per braking	J	1176	1372	1372	1372	1372
	Allowable total work	J	1.5 × 10 ⁶	2.9 × 10 ⁶	2.9 × 10 ⁶	2.9 × 10 ⁶	2.9 × 10 ⁶
	Allowable angular acceleration	rad/s ²	10,000			5,000	
	Brake limit	–	10 million times min.				
	Rating	–	Continuous				
	Insulation class	–	Type F				

Model (R88M-)		400 VAC					
		K90010F	K2K010F	K3K010F	–	–	
Item	Unit	K90010C	K2K010C	K3K010C	K4K510C	K6K010C	
Rated output *1	W	900	2,000	3,000	4,500	6,000	
Rated torque *1	N · m	8.59	19.1	28.7	43.0	57.3	
Rated rotation speed	r/min	1,000					
Maximum rotation speed	r/min	2,000					
Momentary maximum torque *1	N · m	19.3	47.7	71.7	107.0	143.0	
Rated current *1	A (rms)	3.8	8.5	11.3	14.8	19.4	
Momentary maximum current *1	A (rms)	12	30	40	55	74	
Rotor inertia	Without brake	kg · m ²	6.70 × 10 ⁻⁴	30.3 × 10 ⁻⁴	48.4 × 10 ⁻⁴	79.1 × 10 ⁻⁴	101 × 10 ⁻⁴
	With brake	kg · m ²	7.99 × 10 ⁻⁴	31.4 × 10 ⁻⁴	49.2 × 10 ⁻⁴	84.4 × 10 ⁻⁴	107 × 10 ⁻⁴
Applicable load inertia	–	10 times the rotor inertia max. *2					
Torque constant *1	N · m/A	1.72	1.76	1.92	2.05	2.08	
Power rate *1	Without brake	kW/s	110	120	170	233	325
	With brake	kW/s	92.4	116	167	219	307
Mechanical time constant	Without brake	ms	0.66	0.76	0.61	0.55	0.54
	With brake	ms	0.79	0.78	0.62	0.63	0.57
Electrical time constant	ms	11	18	22	20	23	
Allowable radial load *3	N	686	1176	1470	1470	1764	
Allowable thrust load *3	N	196	490	490	490	588	
Weight	Without brake	kg	Approx. 6.7	Approx. 14.0	Approx. 20.0	Approx. 29.4	Approx. 36.4
	With brake	kg	Approx. 8.2	Approx. 17.5	Approx. 23.5	Approx. 33.3	Approx. 40.4
Radiator plate dimensions (material)		270 × 260 × t15 (Al)	470 × 440 × t30 (Al)		470 × 440 × t30 (Al)	550 × 520 × t30 (Al)	
Applicable Servo Drives (R88D-)		KN15F-ECT	KN30F-ECT	KN50F-ECT	KN50F-ECT	KN75F-ECT	
Brake specifications	Brake inertia	kg · m ²	1.35 × 10 ⁻⁴	4.7 × 10 ⁻⁴	4.7 × 10 ⁻⁴	4.7 × 10 ⁻⁴	4.7 × 10 ⁻⁴
	Excitation voltage *4	V	24 VDC ± 10%				
	Power consumption (at 20°C)	W	19	31	34	34	34
	Current consumption (at 20°C)	A	0.79±10%	1.3±10%	1.4±10%	1.4±10%	1.4±10%
	Static friction torque	N · m	13.7 min.	24.5 min.	58.8 min.	58.8 min.	58.8 min.
	Attraction time *5	ms	100 max.	80 max.	150 max.	150 max.	150 max.
	Release time *5	ms	50 max. *6	25 max. *7	50 max. *7	50 max.	50 max.
	Backlash		± 1°				
	Allowable work per braking	J	1176	1372	1372	1372	1372
	Allowable total work	J	1.5 × 10 ⁶	2.9 × 10 ⁶	2.9 × 10 ⁶	2.9 × 10 ⁶	2.9 × 10 ⁶
	Allowable angular acceleration	rad/s ²	10,000			5,000	
	Brake limit	–	10 million times min.				
	Rating	–	Continuous				
	Insulation class	–	Type F				

*1 These are the values when the motor is combined with a drive at normal temperature (20°C, 65%). The momentary maximum torque indicates the standard value.

- *2 Applicable load inertia.
 - The operable load inertia ratio (load inertia/rotor inertia) depends on the mechanical configuration and its rigidity. For a machine with high rigidity, operation is possible even with high load inertia. Select an appropriate motor and confirm that operation is possible.
 - The dynamic brake is intended for emergency stop and therefore has a short-time rating. If the dynamic brake is activated, allow it to be in a stop state for 3 minutes or more to prevent a circuit failure and burning of the Dynamic Brake Resistor.
- *3 The allowable radial and thrust loads are the values determined for a limit of 20,000 hours at normal operating temperatures. The allowable radial loads are applied as shown in the following diagram.

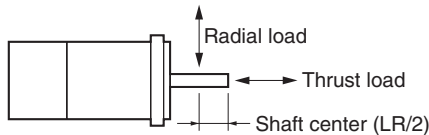

- *4 This is a non-excitation brake. (It is released when excitation voltage is applied.)
- *5 The operation time is the value (reference value) measured with a surge suppressor (CR50500 by Okaya Electric Industries Co., Ltd.).
- *6 Direct current switching with a varistor (TNR9G820K by Nippon Chemi-Con Corporation).
- *7 Direct current switching with a varistor (Z15D151 by Ishizuka Electronics Co.).

● Torque-Rotation Speed Characteristics for 1,000-r/min Servomotors

- 1,000-r/min Servomotors (200/400 VAC)

The following graphs show the characteristics with a 3-m standard cable and a 200-VAC input.

• R88M-K90010H/T/F/C (900 W)

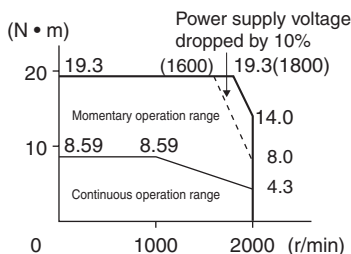

• R88M-K2K010H/T/F/C (2 kW)

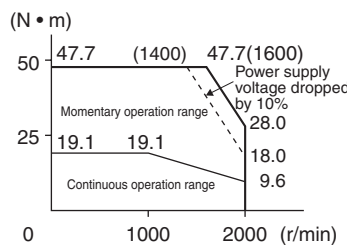

• R88M-K3K010H/T/F/C (3 kW)

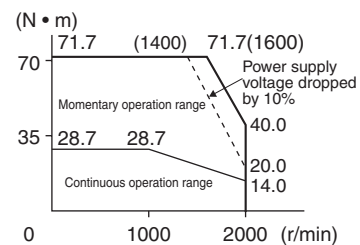

• R88M-K4K510T/C (900 W)

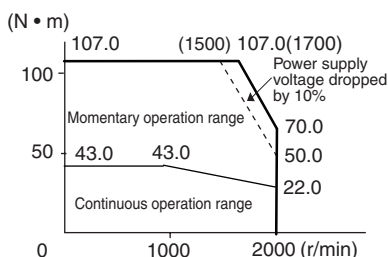

• R88M-K6K010T/C (900 W)

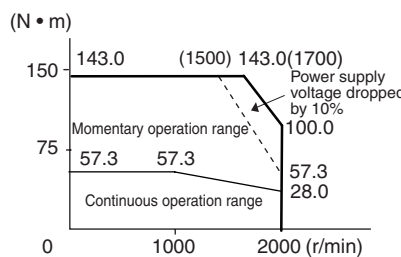

Note 1 The continuous operation range is the range in which continuous operation is possible. Continuous operation at the maximum speed is also possible. However, doing so will reduce the output torque.

- 2 If the motor power cable exceeds 20 m, the voltage drop will increase and the momentary operation range will become narrower.

Temperature Characteristics of the Motor and Mechanical System

- G5-Series AC Servomotors use rare earth magnets (neodymium-iron magnets). The temperature coefficient for these magnets is approx. $-0.13\%/^{\circ}\text{C}$.
As the temperature drops, the motor's momentary maximum torque increases, and as the temperature rises, the motor's momentary maximum torque decreases.
- The momentary maximum torque rises by 4% at a normal temperature of 20°C compared to a temperature of -10°C . Conversely, the momentary maximum torque decreases about 8% when the magnet warms up to 80°C from the normal temperature.
- Generally, when the temperature drops in a mechanical system, the friction torque and the load torque increase. For that reason, overloading may occur at low temperatures.
In particular, in systems that use a Decelerator, the load torque at low temperatures may be nearly twice as much as the load torque at normal temperatures.
Check whether overloading may occur during starting at low temperature.
Also check to see whether abnormal motor overheating or errors occur at high temperatures.
- An increase in load friction torque seemingly increases load inertia.
Therefore, even if the drive gains are adjusted at a normal temperature, the motor may not operate properly at low temperatures. Check to see whether optimal operation can be obtained even at low temperatures.

3-3-3 Encoder Specifications

Incremental Encoder Specifications

Item	Specifications
Encoder system	Optical encoder
	20 bits
Number of output pulses	Phases A and B: 262,144 pulses/rotation Phase Z: 1 pulse/rotation
Power supply voltage	5 VDC \pm 5%
Power supply current	180 mA (max.)
Output signal	+S, -S
Output interface	RS485 compliant

Absolute Encoder Specifications

Item	Specifications
Encoder system	Optical encoder
	17 bits
Number of output pulses	Phases A and B: 32,768 pulses/rotation Phase Z: 1 pulse/rotation
Maximum rotations	-32,768 to +32,767 rotations
Power supply voltage	5 VDC \pm 5%
Power supply current	110 mA (max.)
Applicable battery voltage	3.6 VDC
Current consumption of battery	265 μ A (for a maximum of 5 s right after power interruption) 100 μ A (for operation during power interruption) 3.6 μ A (when power is supplied to the drive)
Output signal	+S, -S
Output interface	RS485 compliant



Additional Information

Multi-rotation Data Backup

- The multi-rotation data will be lost if the battery cable connector is disconnected at the motor when connecting the battery cable for the absolute encoder and battery.
- The multi-rotation data will be lost if CN2 is disconnected when connecting the battery to CN1 without the use of a battery cable for the absolute encoder.

3-4 Reduction Gear Specifications

The following tables list the Reduction Gear models for G5-series Servomotor. Select the model by the Servomotor capacity.

3-4-1 Models and Specifications

3 Arcminutes Max.

● For 3,000-r/min Servomotors

Model			Rated rotation speed	Rated torque	Efficiency	Momentary maximum rotation speed	Momentary maximum torque	Reduction gear inertia	Allowable radial load	Allowable thrust load	Weight
			r/min	N·m	%	r/min	N·m	kg·m ²	N	N	kg
50 W	1/5	R88G-HPG11B05100B□	600	0.50	63	1200	1.51	5.00×10^{-7}	135	538	0.3
	1/9	R88G-HPG11B09050B□	333	1.12	78	666	3.37	3.00×10^{-7}	161	642	0.3
	1/21	R88G-HPG14A21100B□	143	2.18	65	286	6.55	5.00×10^{-6}	340	1358	1.0
	1/33	R88G-HPG14A33050B□	91	3.75	71	182	11.2	4.40×10^{-6}	389	1555	1.0
	1/45	R88G-HPG14A45050B□	67	5.11	71	134	15.3	4.40×10^{-6}	427	1707	1.0
100 W	1/5	R88G-HPG11B05100B□	600	1.28	80	1200	3.80	5.00×10^{-7}	135	538	0.3
	1/11	R88G-HPG14A11100B□	273	2.64	75	546	7.84	6.00×10^{-6}	280	1119	1.0
	1/21	R88G-HPG14A21100B□	143	5.38	80	286	16.0	5.00×10^{-6}	340	1358	1.0
	1/33	R88G-HPG20A33100B□	91	6.86	65	182	20.4	6.50×10^{-6}	916	3226	2.4
	1/45	R88G-HPG20A45100B□	67	9.36	65	134	27.8	6.50×10^{-6}	1006	3541	2.4
200 W	1/5	R88G-HPG14A05200B□	600	2.50	78	1200	7.45	2.07×10^{-5}	221	883	1.0
	1/11	R88G-HPG14A11200B□	273	5.98	85	546	17.9	1.93×10^{-5}	280	1119	1.1
	1/21	R88G-HPG20A21200B□	143	10.2	76	286	30.5	4.90×10^{-5}	800	2817	2.9
	1/33	R88G-HPG20A33200B□	91	17.1	81	182	51.1	4.50×10^{-5}	916	3226	2.9
	1/45	R88G-HPG20A45200B□	67	23.3	81	134	69.6	4.50×10^{-5}	1006	3541	2.9

Model			Rated rotation speed	Rated torque	Efficiency	Momentary maximum rotation speed	Momentary maximum torque	Reduction gear inertia	Allowable radial load	Allowable thrust load	Weight
			r/min	N·m	%	r/min	N·m	kg·m ²	N	N	kg
400 W	1/5	R88G-HPG14A05400B□	600	5.66	87	1200	16.5	2.07×10^{-5}	221	883	1.1
	1/11	R88G-HPG20A11400B□	273	11.7	82	546	34.3	5.67×10^{-5}	659	2320	2.9
	1/21	R88G-HPG20A21400B□	143	23.5	86	286	68.6	4.90×10^{-5}	800	2547	2.9
	1/33	R88G-HPG32A33400B□	91	34.7	81	182	101.6	6.20×10^{-5}	1565	6240	7.5
	1/45	R88G-HPG32A45400B□	67	47.4	81	134	138.5	6.10×10^{-5}	1718	6848	7.5
750 W (200 V)	1/5	R88G-HPG20A05750B□	600	9.96	83	1000	29.5	6.80×10^{-5}	520	1832	2.9
	1/11	R88G-HPG20A11750B□	273	20.0 ^{*1}	88	455	68.7	6.00×10^{-5}	659	2320	3.1
	1/21	R88G-HPG32A21750B□	143	42.3	84	238	125.2	3.00×10^{-4}	1367	5448	7.8
	1/33	R88G-HPG32A33750B□	91	69.7	88	152	206.2	2.70×10^{-4}	1565	6240	7.8
	1/45	R88G-HPG32A45750B□	67	95.0	88	112	281.2	2.70×10^{-4}	1718	6848	7.8
750 W (400 V)	1/5	R88G-HPG32A052K0B□	600	7.65	64	1000	22.9	3.90×10^{-4}	889	3542	7.4
	1/11	R88G-HPG32A112K0B□	273	20.5	78	455	61.4	3.40×10^{-4}	1126	4488	7.9
	1/21	R88G-HPG32A211K5B□	143	42.2	84	238	126.3	3.00×10^{-4}	1367	5448	7.9
	1/33	R88G-HPG32A33600SB□	91	69.4	88	152	207.9	2.80×10^{-4}	1565	6240	7.9
	1/45	R88G-HPG50A451K5B□	67	90.3	84	112	270.6	4.70×10^{-4}	4538	15694	19.0
1 kW	1/5	R88G-HPG32A052K0B□	600	11.4	72	1000	34.4	3.90×10^{-4}	889	3542	7.4
	1/11	R88G-HPG32A112K0B□	273	29.0	83	454	87.2	3.40×10^{-4}	1126	4488	7.9
	1/21	R88G-HPG32A211K5B□	143	58.1	87	238	174.5	3.00×10^{-4}	1367	5448	7.9
	1/33	R88G-HPG50A332K0B□	91	91.3	87	151	274.2	4.80×10^{-4}	4135	14300	19.0
	1/45	R88G-HPG50A451K5B□	67	124.5	87	100 ^{*2}	373.9	4.70×10^{-4}	4538	15694	19.0

Model			Rated rotation speed	Rated torque	Efficiency	Momentary maximum rotation speed	Momentary maximum torque	Reduction gear inertia	Allowable radial load	Allowable thrust load	Weight
			r/min	N·m	%	r/min	N·m	kg·m ²	N	N	kg
1.5 kW	1/5	R88G-HPG32A052K0B□	600	19.1	80	1000	57.2	3.90×10^{-4}	889	3542	7.4
	1/11	R88G-HPG32A112K0B□	273	45.6	87	454	136.9	3.40×10^{-4}	1126	4488	7.9
	1/21	R88G-HPG32A211K5B□	143	90.2	90	238	270.3	3.00×10^{-4}	1367	5448	7.9
	1/33	R88G-HPG50A332K0B□	91	141.7	90	136	424.7	4.80×10^{-4}	4135	14300	19.0
	1/45	R88G-HPG50A451K5B□	67	193.2	90	100*2	579.2	4.70×10^{-4}	4538	15694	19.0
2 kW	1/5	R88G-HPG32A052K0B□	600	26.8	84	1000	80.2	3.90×10^{-4}	889	3542	7.4
	1/11	R88G-HPG32A112K0B□	273	62.4	89	454	187.0	3.40×10^{-4}	1126	4488	7.9
	1/21	R88G-HPG50A212K0B□	143	119.1	89	214*2	357.0	5.80×10^{-4}	3611	12486	19.0
	1/33	R88G-HPG50A332K0B□	91	191.3	91	136*2	573.6	4.80×10^{-4}	4135	14300	19.0
3 kW	1/5	R88G-HPG32A053K0B□	600	42.0	88	1000	125.8	3.80×10^{-4}	889	3542	7.3
	1/11	R88G-HPG50A113K0B□	273	92.4	88	409*2	276.8	7.70×10^{-4}	2974	10285	19.0
	1/21	R88G-HPG50A213K0B□	143	182.5	91	214*2	546.5	5.80×10^{-4}	3611	12486	19.0
4 kW	1/5	R88G-HPG32A054K0B□	600	54.6	86	900*2	164.3	3.80×10^{-4}	889	3542	7.9
	1/11	R88G-HPG50A115K0B□	273	125.7	90	409*2	378.2	8.80×10^{-4}	2974	10285	19.1
5 kW	1/5	R88G-HPG50A055K0B□	600	70.0	88	900*2	209.9	1.20×10^{-3}	2347	8118	18.6
	1/11	R88G-HPG50A115K0B□	273	159.2	91	409*2	477.5	8.80×10^{-4}	2974	10285	19.1

*1 The value is the maximum continuous output torque of the Reduction Gear. Do not exceed the torque.

*2 The value is the allowable maximum rotation speed of the Reduction Gear. Do not exceed the motor shaft rotation speed over 4,500 r/min.

Note 1 The value given for the reduction gear inertia is the Servomotor shaft conversion value.

2 The protection structure of the Servomotor with the reduction gear meets the requirements of IP44.

3 The value given for the allowable radial load is the value at the center of the shaft (T/2).

4 The standard shaft type is a straight shaft. A model with a key and tap is indicated by adding "J" to the end of the model number (the suffix shown in the box).

● For 2,000-r/min Servomotors

Model			Rated rotation speed	Rated torque	Efficiency	Momentary maximum rotation speed	Momentary maximum torque	Reduction gear inertia	Allowable radial load	Allowable thrust load	Weight
			r/min	N·m	%	r/min	N·m	kg·m ²	N	N	kg
400 W	1/5	R88G-HPG32A052K0B□	400	6.49	68	600	19.5	3.90×10^{-4}	889	3542	7.4
	1/11	R88G-HPG32A112K0B□	182	16.8	80	273	50.4	3.40×10^{-4}	1126	4488	7.9
	1/21	R88G-HPG32A211K5B□	95	34.1	85	143	102.3	3.00×10^{-4}	1367	5448	7.9
	1/33	R88G-HPG32A33600SB□	60	55.5	88	91	166.4	2.80×10^{-4}	1565	6240	7.9
	1/45	R88G-HPG32A45400SB□	44	73.9	86	67	221.8	2.70×10^{-4}	1718	6848	7.9
600 W	1/5	R88G-HPG32A052K0B□	400	11.2	78	600	33.5	3.90×10^{-4}	889	3542	7.4
	1/11	R88G-HPG32A112K0B□	182	26.7	85	273	80.3	3.40×10^{-4}	1126	4488	7.9
	1/21	R88G-HPG32A211K5B□	95	53.4	89	143	160.5	3.00×10^{-4}	1367	5448	7.9
	1/33	R88G-HPG32A33600SB□	60	85.9	91	91	258.0	2.80×10^{-4}	1565	6240	7.9
	1/45	R88G-HPG50A451K5B□	44	114.5	89	67	344.0	4.70×10^{-4}	4538	15694	19.0
1 kW	1/5	R88G-HPG32A053K0B□	400	20.3	85	600	60.8	3.90×10^{-4}	889	3542	7.3
	1/11	R88G-HPG32A112K0SB□	182	47.2	90	273	141.6	3.40×10^{-4}	1126	4488	7.8
	1/21	R88G-HPG32A211K0SB□	95	92.2	92	143	276.3	2.90×10^{-4}	1367	5448	7.8
	1/33	R88G-HPG50A332K0SB□	60	144.8	92	91	434.1	4.70×10^{-4}	4135	14300	19.0
	1/45	R88G-HPG50A451K0SB□	44	197.5	92	67	592.2	4.70×10^{-4}	4538	15694	19.0
1.5 kW	1/5	R88G-HPG32A053K0B□	400	31.8	89	600	95.7	3.80×10^{-4}	889	3542	7.3
	1/11	R88G-HPG32A112K0SB□	182	72.5	92	273	217.6	3.40×10^{-4}	1126	4488	7.8
	1/21	R88G-HPG50A213K0B□	95	138.3	92	143	415.4	5.80×10^{-4}	3611	12486	19.0
	1/33	R88G-HPG50A332K0SB□	60	219.7	93	91	659.8	4.70×10^{-4}	4135	14300	19.0

Note 1 The value given for the reduction gear inertia is the Servomotor shaft conversion value.

2 The protection structure of the Servomotor with the reduction gear meets the requirements of IP44.

3 The value given for the allowable radial load is the value at the center of the shaft (T/2).

4 The standard shaft type is a straight shaft. A model with a key and tap is indicated by adding "J" to the end of the model number (the suffix shown in the box).

3 Specifications

Model			Rated rotation speed	Rated torque	Efficiency	Momentary maximum rotation speed	Momentary maximum torque	Reduction gear inertia	Allowable radial load	Allowable thrust load	Weight
			r/min	N·m	%	r/min	N·m	kg·m ²	N	N	kg
2 kW	1/5	R88G-HPG32A053K0B□	400	43.5	91	600	130.6	3.80×10^{-4}	889	3542	7.3
	1/11	R88G-HPG32A112K0SB□	182	97.7	93	273	293.6	3.40×10^{-4}	1126	4488	7.8
	1/21	R88G-HPG50A213K0B□	95	186.5	93	143	560.5	5.80×10^{-4}	3611	12486	19.0
	1/33	R88G-HPG50A332K0SB□	60	270.0 ^{*1}	93	91	850.0 ^{*3}	4.70×10^{-4}	4135	14300	19.0
3 kW	1/5	R88G-HPG32A054K0B□	400	64.4	90	600	197.8	3.80×10^{-4}	889	3542	7.9
	1/11	R88G-HPG50A115K0B□	182	144.7	92	273	435.2	8.80×10^{-4}	2974	10285	19.1
	1/21	R88G-HPG50A213K0SB□	95	260.0 ^{*1}	93	143	839.8	6.90×10^{-4}	3611	12486	19.1
	1/25	R88G-HPG65A253K0SB□	80	321.8	90	120	967.5	3.00×10^{-3}	7846	28654	52.0
4 kW	1/5	R88G-HPG50A055K0SB□	400	86.9	91	600	260.7	1.10×10^{-3}	2347	8118	22.0
	1/11	R88G-HPG50A115K0SB□	182	195.4	93	273	586.2	8.40×10^{-4}	2974	10285	23.5
	1/20	R88G-HPG65A205K0SB□	100	347.6	91	150	1042.9	2.85×10^{-3}	7338	26799	55.4
	1/25	R88G-HPG65A255K0SB□	80	439.3	92	120	1317.9	2.81×10^{-3}	7846	28654	55.4
5 kW	1/5	R88G-HPG50A055K0SB□	400	109.9	92	600	329.4	1.10×10^{-3}	2347	8118	22.0
	1/11	R88G-HPG50A115K0SB□	182	200.0 ^{*1}	93	273	732.5	8.40×10^{-4}	2974	10285	23.5
	1/20	R88G-HPG65A205K0SB□	100	439.7	92	150	1317.4	2.85×10^{-3}	7338	26799	55.4
	1/25	R88G-HPG65A255K0SB□	80	555.7	93	120	1664.7	2.81×10^{-3}	7846	28654	55.4

*1 The value is the maximum continuous output torque of the Reduction Gear. Do not exceed the torque.

*2 The value is the allowable maximum rotation speed of the Reduction Gear. Do not exceed the motor shaft rotation speed over 4,500 r/min.

*3 The value is the maximum allowable torque of the Reduction Gear. Do not exceed the torque.

Note 1 The value given for the reduction gear inertia is the Servomotor shaft conversion value.

2 The protection structure of the Servomotor with the reduction gear meets the requirements of IP44.

3 The value given for the allowable radial load is the value at the center of the shaft (LR/2).

4 The standard shaft type is a straight shaft. A model with a key and tap is indicated by adding "J" to the end of the model number (the suffix shown in the box).

● For 1,000-r/min Servomotors

Model			Rated rotation speed	Rated torque	Efficiency	Momentary maximum rotation speed	Momentary maximum torque	Reduction gear inertia	Allowable radial load	Allowable thrust load	Weight
			r/min	N·m	%	r/min	N·m	kg·m ²	N	N	kg
900 W	1/5	R88G-HPG32A05900TB□	200	39.9	93	400	89.7	3.80×10^{-4}	889	3542	7.9
	1/11	R88G-HPG32A11900TB□	90	88.8	94	182	199.6	3.40×10^{-4}	1126	4488	8.4
	1/21	R88G-HPG50A21900TB□	47	169.6	94	95	381.0	7.00×10^{-4}	3611	12486	19.1
	1/33	R88G-HPG50A33900TB□	30	266.5	94	60	598.7	5.90×10^{-4}	4135	14300	19.1
2 kW	1/5	R88G-HPG32A052K0TB□	200	90.7	95	400	226.6	4.90×10^{-4}	889	3542	8.90
	1/11	R88G-HPG50A112K0TB□	90	197.5	94	182	493.2	8.40×10^{-4}	2974	10285	20.1
	1/21	R88G-HPG50A212K0TB□	47	260.0 ^{*1}	95	95	850.0 ^{*1}	6.50×10^{-3}	3611	12486	20.1
	1/25	R88G-HPG65A255K0SB□	40	448.9	94	80	1121.0	2.81×10^{-3}	7846	28654	55.4
3 kW	1/5	R88G-HPG50A055K0SB□	200	134.9	94	400	337.0	1.10×10^{-3}	2347	8118	22.0
	1/11	R88G-HPG50A115K0SB□	90	246.0 ^{*1}	95	182	749.3	8.40×10^{-4}	2974	10285	23.5
	1/20	R88G-HPG65A205K0SB□	50	539.6	94	100	1348.0	2.85×10^{-3}	7338	26799	55.4
	1/25	R88G-HPG65A255K0SB□	40	674.5	94	80	1684.9	2.81×10^{-3}	7846	28654	55.4

*1 The value is the maximum continuous output torque of the Reduction Gear. Do not exceed the torque.

Note 1 The value given for the reduction gear inertia is the Servomotor shaft conversion value.

2 The protection structure of the Servomotor with the reduction gear meets the requirements of IP44.

3 The value given for the allowable radial load is the value at the center of the shaft (T/2).

4 The standard shaft type is a straight shaft. A model with a key and tap is indicated by adding "J" to the end of the model number (the suffix shown in the box).

15 Arcminutes Max.

● For 3,000-r/min Servomotors

Model			Rated rotation speed	Rated torque	Efficiency	Momentary maximum rotation speed	Momentary maximum torque	Reduction gear inertia	Allowable radial load	Allowable thrust load	Weight
			r/min	N·m	%	r/min	N·m	kg·m ²	N	N	kg
50 W	1/5	R88G-VRSF05B100CJ	600	0.52	65	1000	1.56	4.00×10^{-6}	392	196	0.55
	1/9	R88G-VRSF09B100CJ	333	0.94	65	556	2.81	3.50×10^{-6}	441	220	0.55
	1/15	R88G-VRSF15B100CJ	200	1.68	70	333	5.04	3.50×10^{-6}	588	294	0.70
	1/25	R88G-VRSF25B100CJ	120	2.80	70	200	8.40	3.25×10^{-6}	686	343	0.70
100 W	1/5	R88G-VRSF05B100CJ	600	1.20	75	1000	3.56	4.00×10^{-6}	392	196	0.55
	1/9	R88G-VRSF09B100CJ	333	2.30	80	556	6.84	3.50×10^{-6}	441	220	0.55
	1/15	R88G-VRSF15B100CJ	200	3.84	80	333	11.4	3.50×10^{-6}	588	294	0.70
	1/25	R88G-VRSF25B100CJ	120	6.40	80	200	19.0	3.25×10^{-6}	686	343	0.70
200 W	1/5	R88G-VRSF05B200CJ	600	2.72	85	1000	8.12	1.18×10^{-5}	392	196	0.72
	1/9	R88G-VRSF09C200CJ	333	3.80	66	556	11.3	2.75×10^{-5}	931	465	1.70
	1/15	R88G-VRSF15C200CJ	200	6.34	66	333	18.9	3.00×10^{-5}	1176	588	2.10
	1/25	R88G-VRSF25C200CJ	120	11.2	70	200	33.4	2.88×10^{-5}	1323	661	2.10
400 W	1/5	R88G-VRSF05C400CJ	600	5.40	85	1000	15.6 (15.3)	3.63×10^{-5}	784	392	1.70
	1/9	R88G-VRSF09C400CJ	333	9.50	83	556	27.4 (26.8)	2.75×10^{-5}	931	465	1.70
	1/15	R88G-VRSF15C400CJ	200	15.8	83	333	45.7 (44.8)	3.00×10^{-5}	1176	588	2.10
	1/25	R88G-VRSF25C400CJ	120	26.4	83	200	76.1 (74.7)	2.88×10^{-5}	1323	661	2.10
750 W	1/5	R88G-VRSF05C750CJ	600	10.7	90	1000	31.7	7.13×10^{-5}	784	392	2.10
	1/9	R88G-VRSF09D750CJ	333	18.2	85	556	53.9	6.50×10^{-5}	1176	588	3.40
	1/15	R88G-VRSF15D750CJ	200	30.4	85	333	89.9	7.00×10^{-5}	1372	686	3.80
	1/25	R88G-VRSF25D750CJ	120	50.7	85	200	149.8	6.80×10^{-5}	1617	808	3.80

Note 1 The value in the brackets indicates the value of the Servomotor with 100-V power supply.

2 The value given for the reduction gear inertia is the Servomotor shaft conversion value.

3 The protection structure of the Servomotor with the reduction gear meets the requirements of IP44.

4 The value given for the allowable radial load is the value at the center of the shaft (T/2).

5 The standard shaft type is a straight shaft.

6 The allowable input rotation speed of the Reduction Gear is 5,000 r/min.
Do not exceed the limit.

3-5 Cable and Connector Specifications

The specifications of the cables to connect Servo Drives and Servomotors are shown below. The information on the cable types are also provided.

Select the optimum cable according to the Servomotor.

3-5-1 Bend Radius of Robot Cable

If the cable is used at a moving part, use a robot cable.

For bend radius limit of robot cable, the wire rod with the durability of more than 20 million times of use is used.



Precautions for Correct Use

- As for the limit data of bend radius durability is reference only, use cables with margin.
- The data of the minimum bend radius indicates the number of cracks or scratches that occur on sheath through the functional flow, and does not cover the disconnection of shielded wire.
- Malfunction or grounding fault may be occurred by dielectric breakdown if cables are used with a smaller radius of the minimum bend radius.

Moving Flexural Testing

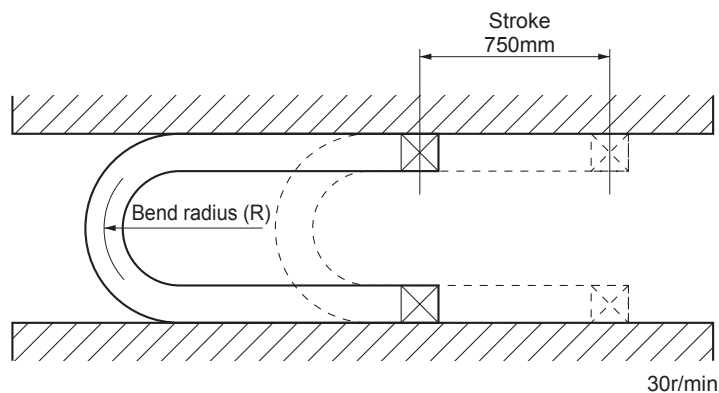

Note The following shows the stroke in some parts of the model.

R88A-CRK□	: 500mm
R88A-CAKA□SR	: 1000mm
R88A-CAKA□BR (3 to 20m)	: 1000mm

Encoder Cables

Model	Minimum bending radius (R)
R88A-CRKA□□□CR ^{*1}	33 mm
R88A-CRKA△△△CR ^{*2}	48 mm
R88A-CRKC□□□NR ^{*1}	42 mm
R88A-CRKC△△△NR ^{*2}	48 mm

*1 Numbers 003 to 020 are indicated in □□□.

*2 Numbers 030 to 050 are indicated in △△△.

Power Cables without Brakes

Model	Minimum bending radius (R)
R88A-CAKA□□□SR ^{*1}	40 mm
R88A-CAGB□□□SR ^{*1}	90 mm
R88A-CAGD□□□SR ^{*1}	100 mm

*1 Numbers 003 to 020 are indicated in □□□.

Power Cables with Brakes

Model	Cable types	Minimum bending radius (R)
R88A-CAGB□□□BR ^{*1}	Power Cables	90 mm
	Brake Cables	45 mm
R88A-CAKF□□□BR ^{*1}	Power Cables	90 mm
	Brake Cables	45 mm
R88A-CAGD□□□BR ^{*1}	Power Cables	100 mm
	Brake Cables	45 mm

*1 Numbers 003 to 020 are indicated in □□□.

Brake Cables

Model	Minimum bending radius (R)
R88A-CAKA□□□BR ^{*1}	30 mm
R88A-CAKA△△△BR ^{*2}	45 mm

*1 Numbers 003 to 020 are indicated in □□□.

*2 Numbers 030 to 050 are indicated in △△△.

3-5-2 Encoder Cable Specifications

These cables are used to connect the encoder between the Servo Drive and the Servomotor. Select the cable matching the Servomotor.

Encoder Cables (Standard Cable)

● R88A-CRKA□C

Cable types

(For both absolute encoders and incremental encoders: [100 V and 200 V] For 3,000-r/min Servomotors of 50 to 750 W)

Model	Length (L)	Outer diameter of sheath	Weight
R88A-CRKA003C	3 m	ø5.3	Approx. 0.1 kg
R88A-CRKA005C	5 m		Approx. 0.2 kg
R88A-CRKA010C	10 m		Approx. 0.4 kg
R88A-CRKA015C	15 m		Approx. 0.6 kg
R88A-CRKA020C	20 m		Approx. 0.8 kg
R88A-CRKA030C	30 m	ø6.8	Approx. 2.4 kg
R88A-CRKA040C	40 m		Approx. 3.2 kg
R88A-CRKA050C	50 m		Approx. 4.0 kg

Connection configuration and external dimensions

[R88A-CRKA□C : 3 to 20m]

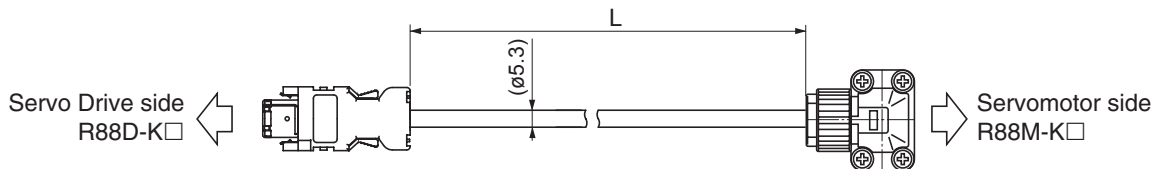

[R88A-CRKA□C : 30 to 50m]

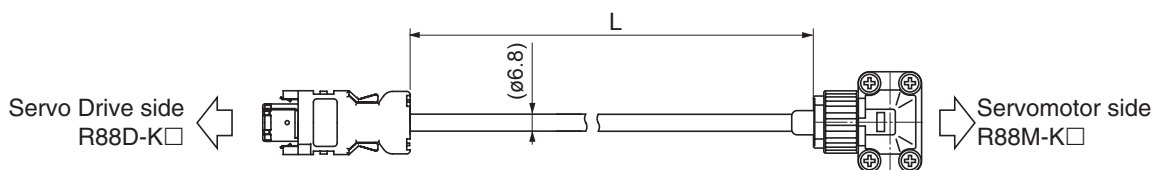

Wiring

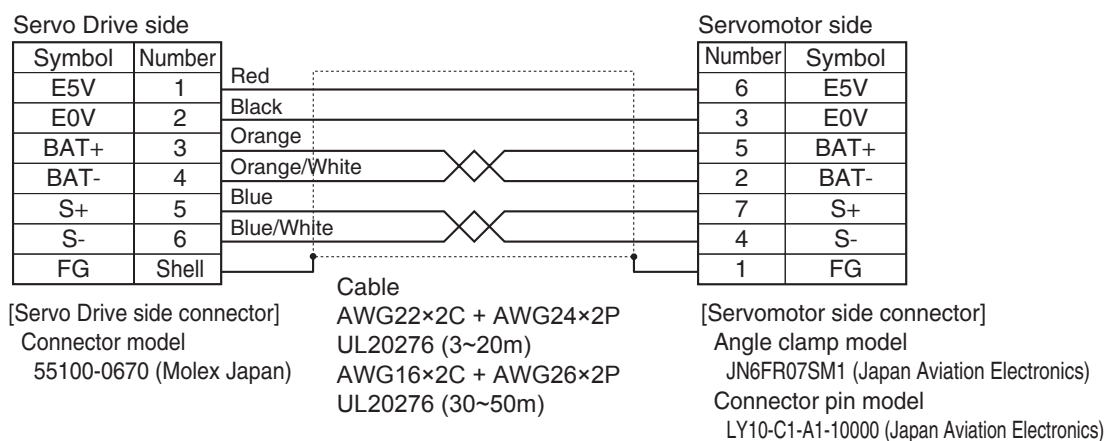

● R88A-CRKC□N

Cable types

(For both absolute encoders and incremental encoders: [100 V and 200 V] For 3,000-r/min Servomotors of 1 kW or more, [400 V] 3,000-r/min Servomotors, 2,000-r/min Servomotors and 1,000-r/min Servomotors)

Model	Length (L)	Outer diameter of sheath	Weight
R88A-CRKC003N	3 m	ø6.8	Approx. 0.2 kg
R88A-CRKC005N	5 m		Approx. 0.4 kg
R88A-CRKC010N	10 m		Approx. 0.7 kg
R88A-CRKC015N	15 m		Approx. 1.1 kg
R88A-CRKC020N	20 m		Approx. 1.4 kg
R88A-CRKC030N	30 m		Approx. 2.4 kg
R88A-CRKC040N	40 m		Approx. 3.2 kg
R88A-CRKC050N	50 m		Approx. 4.0 kg

Connection configuration and external dimensions

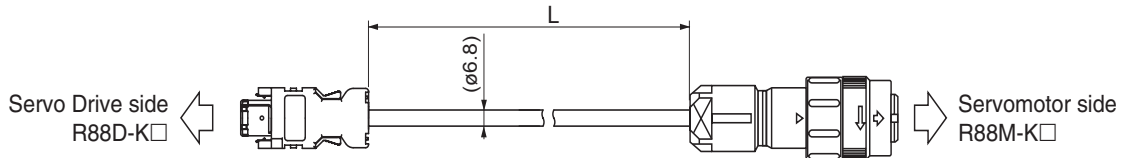

Wiring

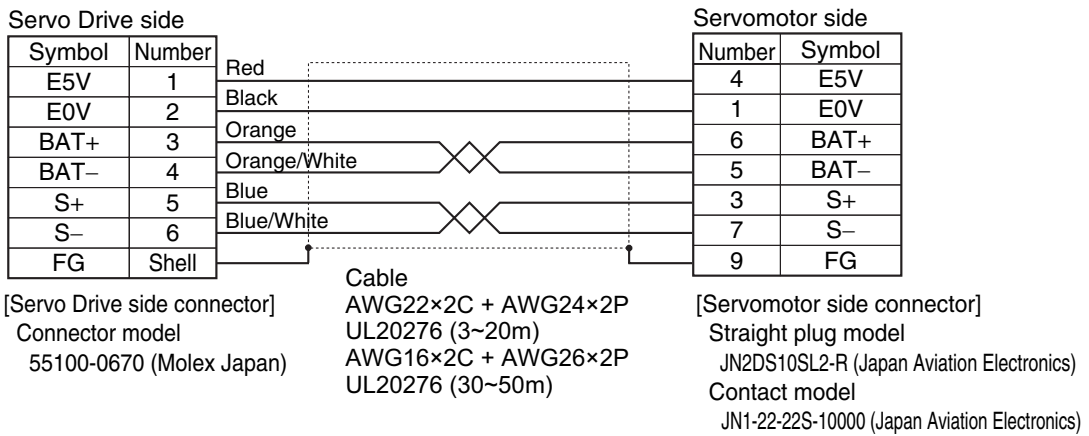

Encoder Cables (Robot Cable)

● R88A-CRKA□CR

Cable types

(For both absolute encoders and incremental encoders: [100 V and 200 V] For 3,000-r/min Servomotors of 50 to 750 W)

Model	Length (L)	Outer diameter of sheath	Minimum bending radius (R) ^{*1}	Weight
R88A-CRKA003CR	3m	ø5.3	33mm	Approx. 0.1 kg
R88A-CRKA005CR	5m			Approx. 0.2 kg
R88A-CRKA010CR	10m			Approx. 0.4 kg
R88A-CRKA015CR	15m			Approx. 0.6 kg
R88A-CRKA020CR	20m			Approx. 0.8 kg
R88A-CRKA030CR	30m	ø7.7	48mm	Approx. 3.0 kg
R88A-CRKA040CR	40m			Approx. 4.0 kg
R88A-CRKA050CR	50m			Approx. 5.0 kg

*1 For information on minimum bend radius, refer to 3-5-1 Bend Radius of Robot Cable on page 3-67.

Connection configuration and external dimensions

[R88A-CRKA□CR : 3 to 20m]

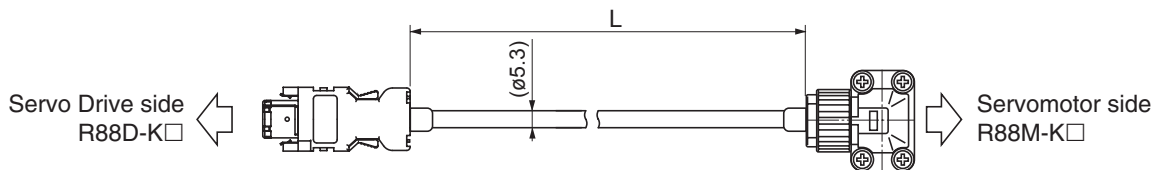

[R88A-CRKA□CR : 30 to 50m]

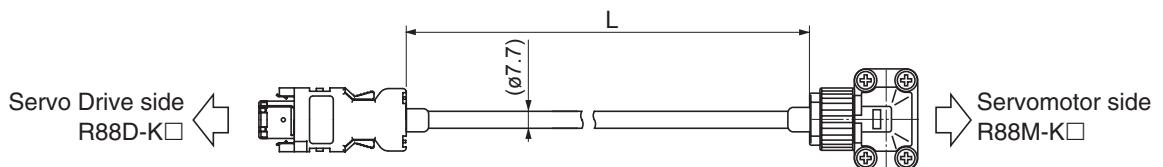

Wiring (3 to 20m)

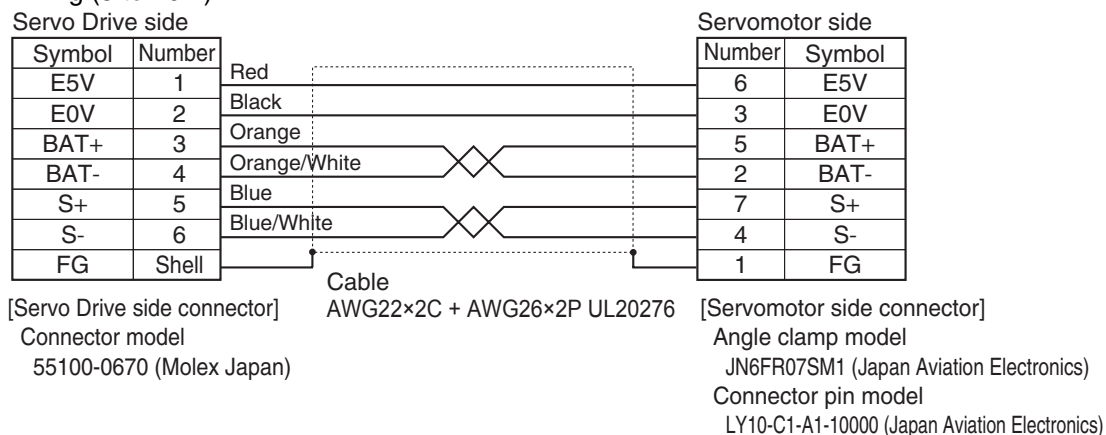

Wiring (30 to 50m)

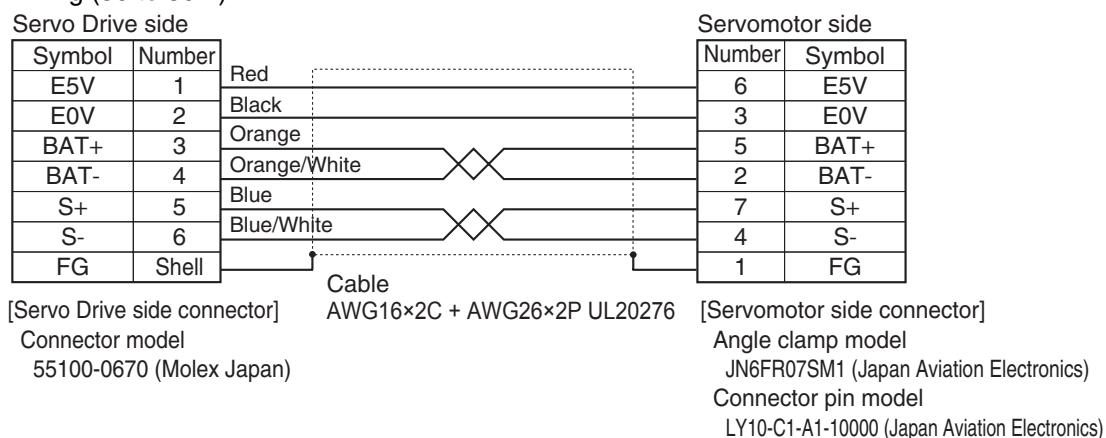

● R88A-CRKC□NR

Cable types

(For both absolute encoders and incremental encoders: [100 V and 200 V] For 3,000-r/min Servomotors of 1 kW or more, [400 V] 3,000-r/min Servomotors, 2,000-r/min Servomotors and 1,000-r/min Servomotors)

Model	Length (L)	Outer diameter of sheath	Minimum bending radius (R) ^{*1}	Weight
R88A-CRKC003NR	3 m	ø6.8	42 mm	Approx. 0.2 kg
R88A-CRKC005NR	5 m			Approx. 0.4 kg
R88A-CRKC010NR	10 m			Approx. 0.7 kg
R88A-CRKC015NR	15 m			Approx. 1.1 kg
R88A-CRKC020NR	20 m			Approx. 5.0 kg
R88A-CRKC030NR	30 m	ø7.7	48 mm	Approx. 3.0 kg
R88A-CRKC040NR	40 m			Approx. 4.0 kg
R88A-CRKC050NR	50 m			Approx. 5.0 kg

*1 For information on minimum bend radius, refer to 3-5-1 Bend Radius of Robot Cable on page 3-67.

Connection configuration and external dimensions

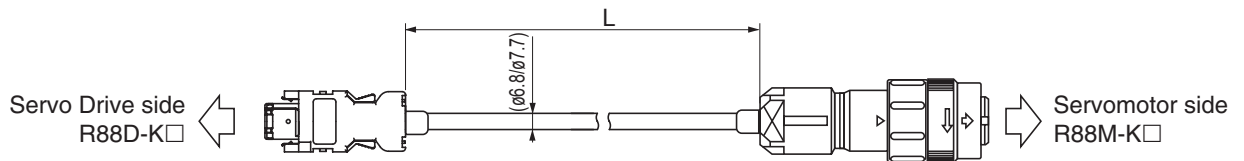

Wiring (3 to 20m)

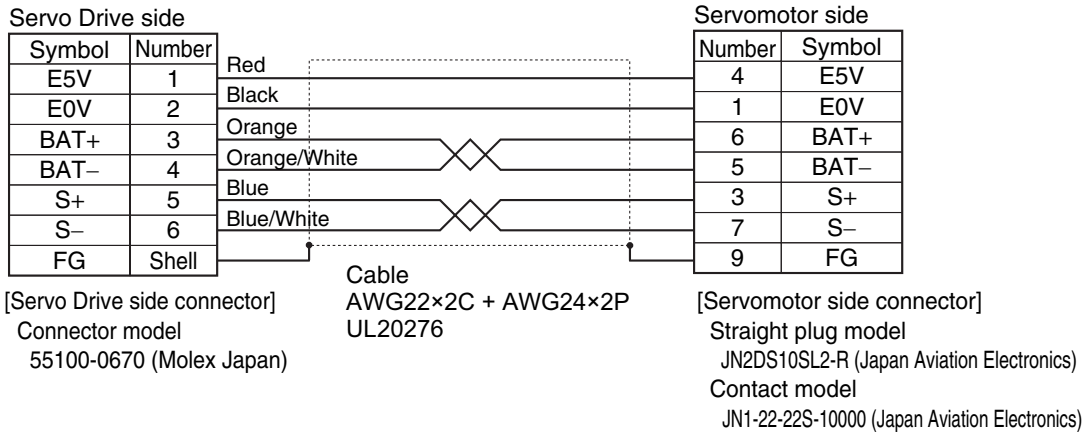

Wiring (30 to 50m)

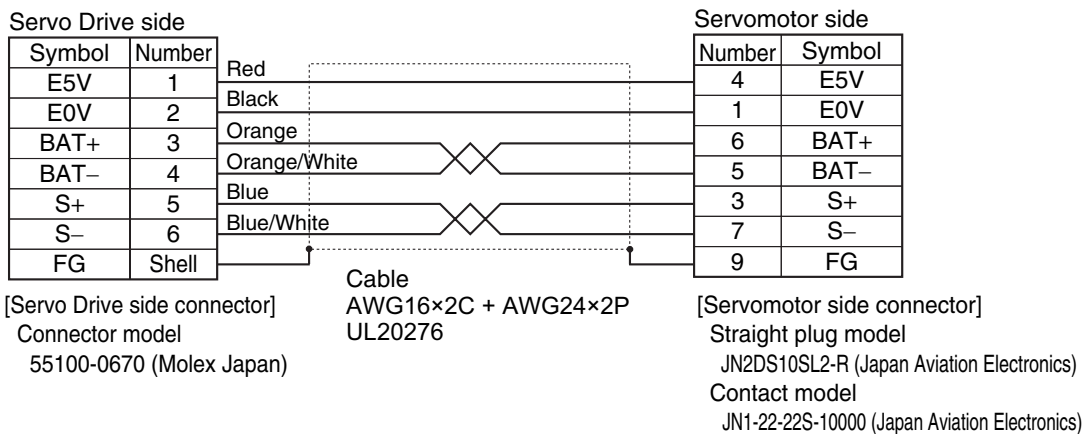

3-5-3 Absolute Encoder Battery Cable Specifications

Use the following Cable when using an absolute encoder.

Cable Model

Model	Length (L)	Battery	Weight
R88A-CRGD0R3C	0.3 m	Not included.	Approx. 0.1 kg
R88A-CRGD0R3C-BS	0.3 m	One Battery (Model: R88A-BAT01G) included.	Approx. 0.1 kg

Connection Configuration and External Dimensions

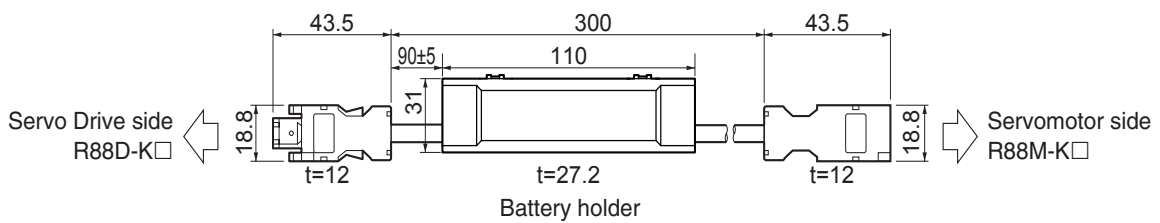

Wiring

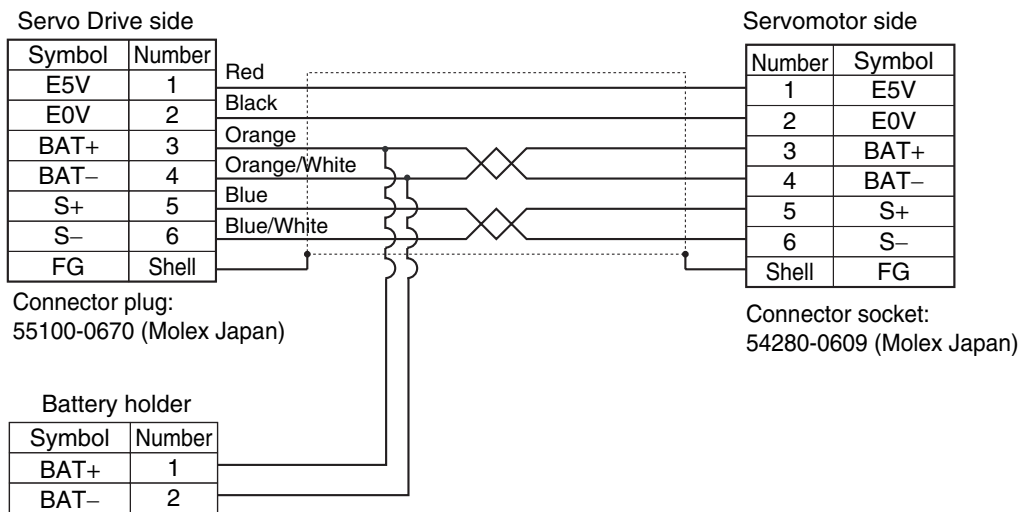

3-5-4 Motor Power Cable Specifications

These cables connect the Servo Drive and the Servomotor. Select the cable matching the Servomotor.

Precautions for Correct Use

If the cable is used at a moving part, use a robot cable.

Power Cables without Brakes (Standard Cable)

● R88A-CAKA□S

Cable types

[100 V and 200 V] (For 3,000-r/min Servomotors of 50 to 750 W)

Model	Length (L)	Outer diameter of sheath	Weight
R88A-CAKA003S	3 m	ø6.0	Approx. 0.2 kg
R88A-CAKA005S	5 m		Approx. 0.3 kg
R88A-CAKA010S	10 m		Approx. 0.5 kg
R88A-CAKA015S	15 m		Approx. 0.8 kg
R88A-CAKA020S	20 m		Approx. 1.1 kg
R88A-CAKA030S	30 m		Approx. 1.6 kg
R88A-CAKA040S	40 m		Approx. 2.1 kg
R88A-CAKA050S	50 m		Approx. 2.6 kg

Connection configuration and external dimensions

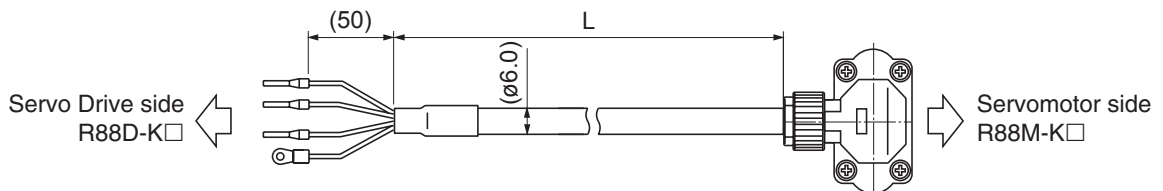

Wiring

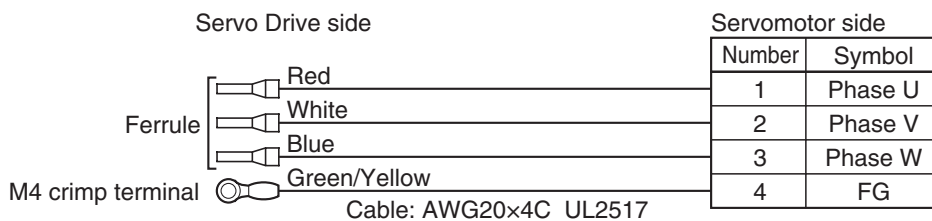

[Servomotor side connector]

Angle plug model

JN8FT04SJ1 (Japan Aviation Electronics)

Connector pin model

ST-TMH-S-C1B-3500-A534G (Japan Aviation Electronics)

● **R88A-CAGB□S**

Cable types

200 V:

(For 3,000-r/min Servomotors of 1 to 2 kW, 2,000-r/min Servomotors of 1 to 2 kW, 1,000-r/min Servomotors of 900 W)

400 V:

(For 3,000-r/min Servomotors of 750 W to 2 kW, 2,000-r/min Servomotors of 400 W to 2 kW, 1,000-r/min Servomotors of 900 W)

Model	Length (L)	Outer diameter of sheath	Weight
R88A-CAGB003S	3 m	ø10.4	Approx. 0.7 kg
R88A-CAGB005S	5 m		Approx. 1.0 kg
R88A-CAGB010S	10 m		Approx. 2.0 kg
R88A-CAGB015S	15 m		Approx. 2.9 kg
R88A-CAGB020S	20 m		Approx. 3.8 kg
R88A-CAGB030S	30 m		Approx. 5.6 kg
R88A-CAGB040S	40 m		Approx. 7.4 kg
R88A-CAGB050S	50 m		Approx. 9.2 kg

Connection configuration and external dimensions

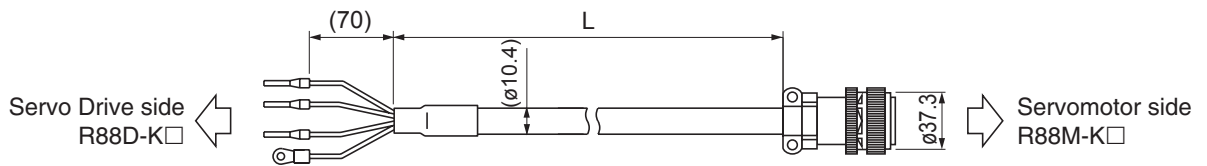

Wiring

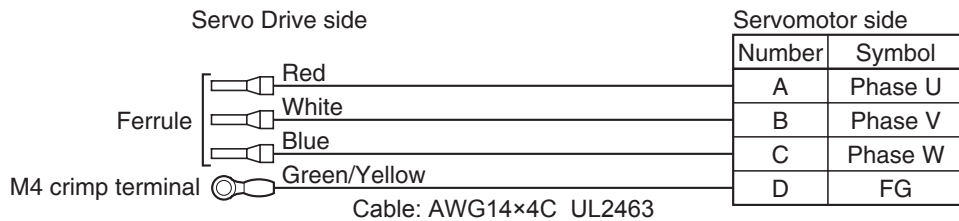

[Servomotor side connector]

Straight plug model

N/MS3106B20-4S (Japan Aviation Electronics)

Cable clamp model

N/MS3057-12A (Japan Aviation Electronics)

● R88A-CAGD□S

Cable types

(For 3,000-r/min Servomotors of 3 to 5 kW, 2,000-r/min Servomotors of 3 to 5 kW, 1,000-r/min Servomotors of 2 to 4.5 kW)

Model	Length (L)	Outer diameter of sheath	Weight
R88A-CAGD003S	3 m	ø14.7	Approx. 1.3 kg
R88A-CAGD005S	5 m		Approx. 2.1 kg
R88A-CAGD010S	10 m		Approx. 4.0 kg
R88A-CAGD015S	15 m		Approx. 6.0 kg
R88A-CAGD020S	20 m		Approx. 8.0 kg
R88A-CAGD030S	30 m		Approx. 11.9 kg
R88A-CAGD040S	40 m		Approx. 15.8 kg
R88A-CAGD050S	50 m		Approx. 19.7 kg

Connection configuration and external dimensions

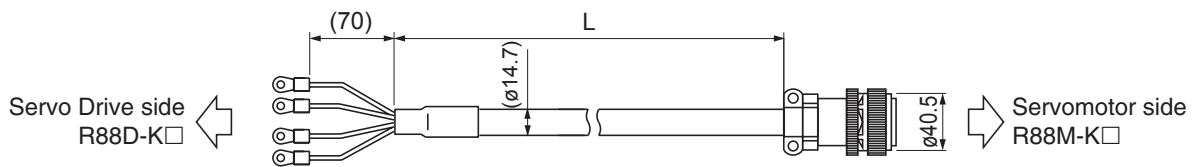

Wiring

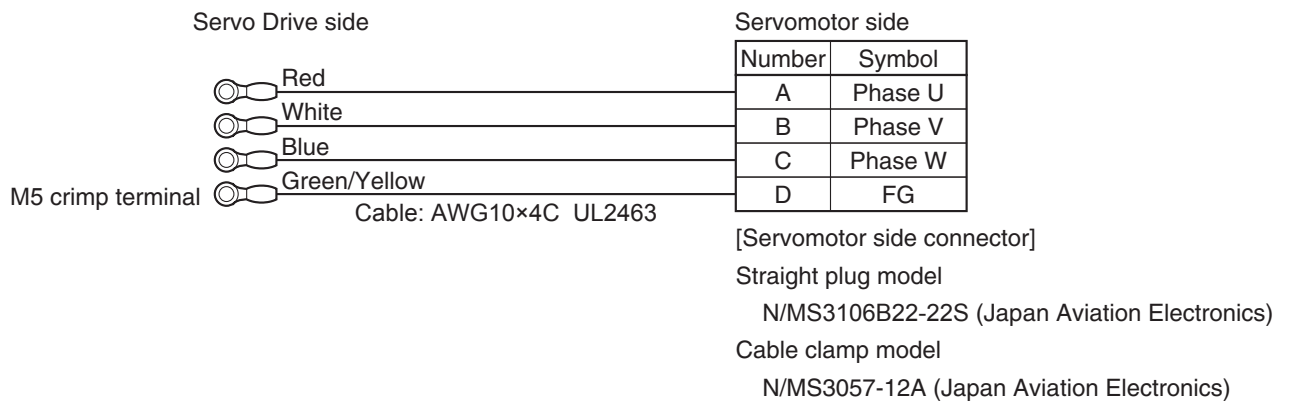

● **R88A-CAGE□S**

Cable types

(For 2,000-r/min Servomotors of 7.5 kW, 1,000-r/min Servomotors of 6 kW)

Model	Length (L)	Outer diameter of sheath	Weight
R88A-CAGE003S	3 m	ø28.5	Approx. 4.0 kg
R88A-CAGE005S	5 m		Approx. 6.5 kg
R88A-CAGE010S	10 m		Approx. 12.6 kg
R88A-CAGE015S	15 m		Approx. 18.8 kg
R88A-CAGE020S	20 m		Approx. 24.9 kg
R88A-CAGE030S	30 m		Approx. 37.2 kg
R88A-CAGE040S	40 m		Approx. 49.5 kg
R88A-CAGE050S	50 m		Approx. 61.8 kg

Connection configuration and external dimensions

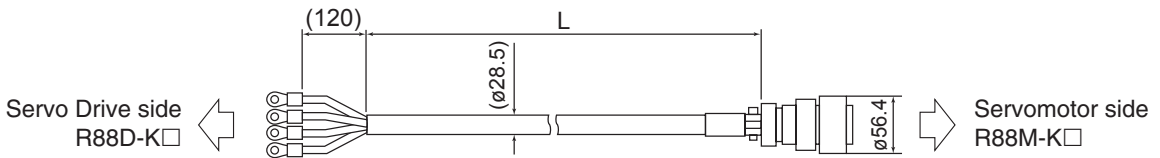

Wiring

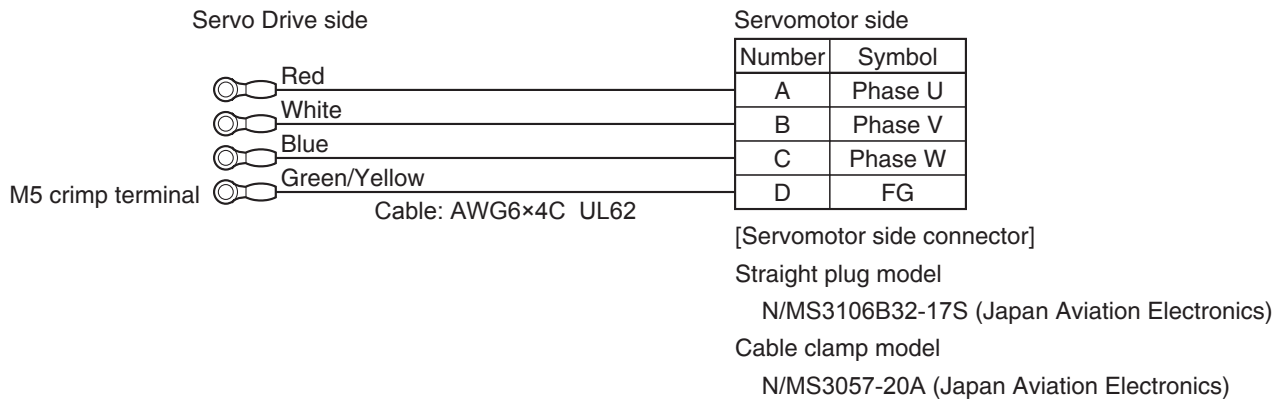

Power Cables without Brakes (Robot Cable)

● R88A-CAKA□SR

Cable types

[100 V and 200 V] (For 3,000-r/min Servomotors of 50 to 750 W)

Model	Length (L)	Outer diameter of sheath	Minimum bending radius (R) ^{*1}	Weight
R88A-CAKA003SR	3 m	ø6.0	40 mm	Approx. 0.2 kg
R88A-CAKA005SR	5 m			Approx. 0.3 kg
R88A-CAKA010SR	10 m			Approx. 0.6 kg
R88A-CAKA015SR	15 m			Approx. 0.9 kg
R88A-CAKA020SR	20 m			Approx. 1.2 kg
R88A-CAKA030SR	30 m			Approx. 1.7 kg
R88A-CAKA040SR	40 m			Approx. 2.3 kg
R88A-CAKA050SR	50 m			Approx. 2.9 kg

*1 For information on minimum bend radius, refer to 3-5-1 Bend Radius of Robot Cable on page 3-67.

Connection configuration and external dimensions

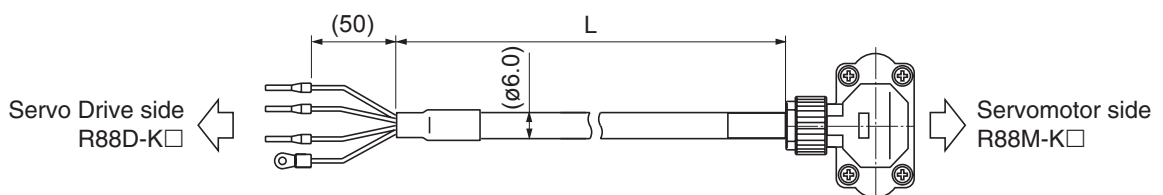

Wiring

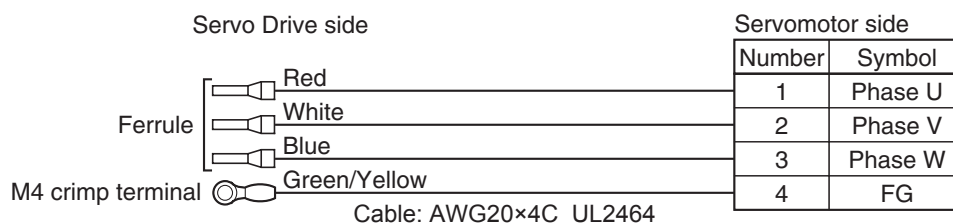

[Servomotor side connector]

Angle plug model

JN8FT04SJ1 (Japan Aviation Electronics)

Connector pin model

ST-TMH-S-C1B-3500-A534G

(Japan Aviation Electronics)

● **R88A-CAGB□SR**

Cable types

200 V:

(For 3,000-r/min Servomotors of 1 to 2 kW, 2,000-r/min Servomotors of 1 to 2 kW, 1,000-r/min Servomotors of 900 W)

400 V:

(For 3,000-r/min Servomotors of 750W to 2 kW, 2,000-r/min Servomotors of 400 W to 2 kW, 1,000-r/min Servomotors of 900 W)

Model	Length (L)	Outer diameter of sheath	Minimum bending radius (R) *1	Weight
R88A-CAGB003SR	3 m	ø12.7	90 mm	Approx. 0.8 kg
R88A-CAGB005SR	5 m			Approx. 1.3 kg
R88A-CAGB010SR	10 m			Approx. 2.4 kg
R88A-CAGB015SR	15 m			Approx. 3.5 kg
R88A-CAGB020SR	20 m			Approx. 4.6 kg
R88A-CAGB030SR	30 m			Approx. 6.9 kg
R88A-CAGB040SR	40 m			Approx. 19.2 kg
R88A-CAGB050SR	50 m			Approx. 11.4 kg

*1 For information on minimum bend radius, refer to 3-5-1 Bend Radius of Robot Cable on page 3-67.

Connection configuration and external dimensions

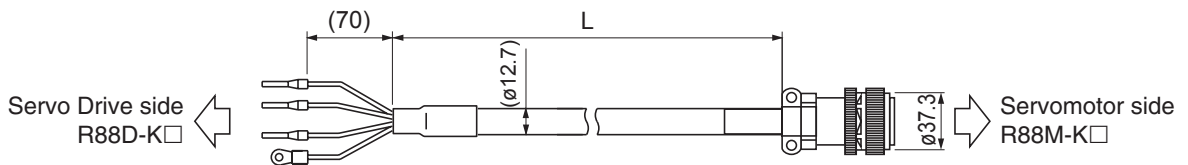

Wiring

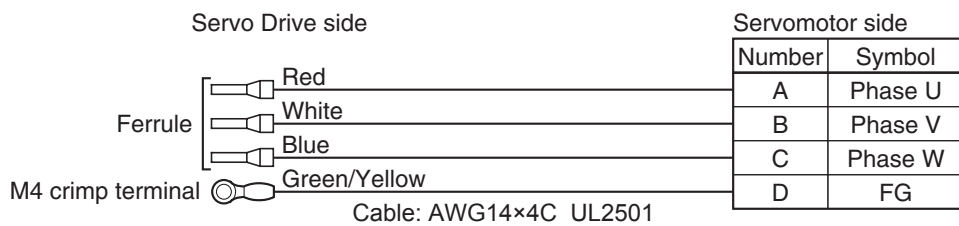

[Servomotor side connector]

Straight plug model

N/MS3106B20-4S (Japan Aviation Electronics)

Cable clamp model

N/MS3057-12A (Japan Aviation Electronics)

● R88A-CAGD□SR

Cable types

(For 3,000-r/min Servomotors of 3 to 5 kW, 2,000-r/min Servomotors of 3 to 5 kW, 1,000-r/min Servomotors of 2 to 4.5 kW)

Model	Length (L)	Outer diameter of sheath	Minimum bending radius (R) *1	Weight
R88A-CAGD003SR	3 m	ø15.6	100 mm	Approx. 1.4 kg
R88A-CAGD005SR	5 m			Approx. 2.2 kg
R88A-CAGD010SR	10 m			Approx. 4.2 kg
R88A-CAGD015SR	15 m			Approx. 6.3 kg
R88A-CAGD020SR	20 m			Approx. 8.3 kg
R88A-CAGD030SR	30 m			Approx. 12.4 kg
R88A-CAGD040SR	40 m			Approx. 16.4 kg
R88A-CAGD050SR	50 m			Approx. 20.5 kg

*1 For information on minimum bend radius, refer to 3-5-1 Bend Radius of Robot Cable on page 3-67.

Connection configuration and external dimensions

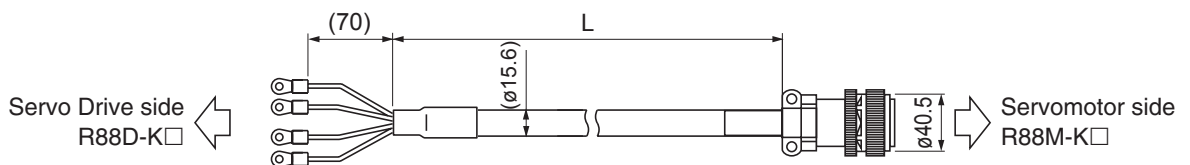

Wiring

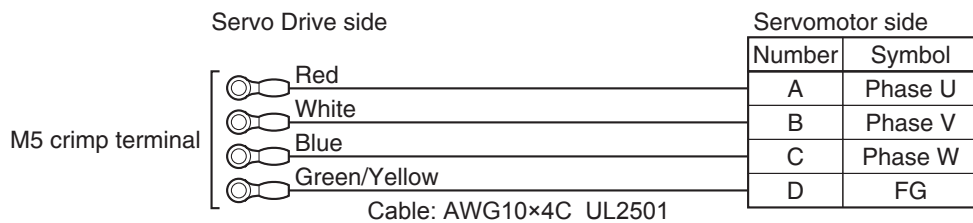

[Servomotor side connector]

Straight plug model

N/MS3106B22-22S (Japan Aviation Electronics)

Cable clamp model

N/MS3057-12A (Japan Aviation Electronics)

Power Cables with Brakes (Standard Cable)

● R88A-CAGB□B

Cable types

200 V:

(For 3,000-r/min Servomotors of 1 to 2 kW, 2,000-r/min Servomotors of 1 to 2 kW, 1,000-r/min Servomotors of 900 W)

Model	Length (L)	Outer diameter of sheath	Weight
R88A-CAGB003B	3 m	ø10.4/ø5.4	Approx. 0.8 kg
R88A-CAGB005B	5 m		Approx. 1.3 kg
R88A-CAGB010B	10 m		Approx. 2.4 kg
R88A-CAGB015B	15 m		Approx. 3.5 kg
R88A-CAGB020B	20 m		Approx. 4.6 kg
R88A-CAGB030B	30 m		Approx. 6.8 kg
R88A-CAGB040B	40 m		Approx. 9.1 kg
R88A-CAGB050B	50 m		Approx. 11.3 kg

Connection configuration and external dimensions

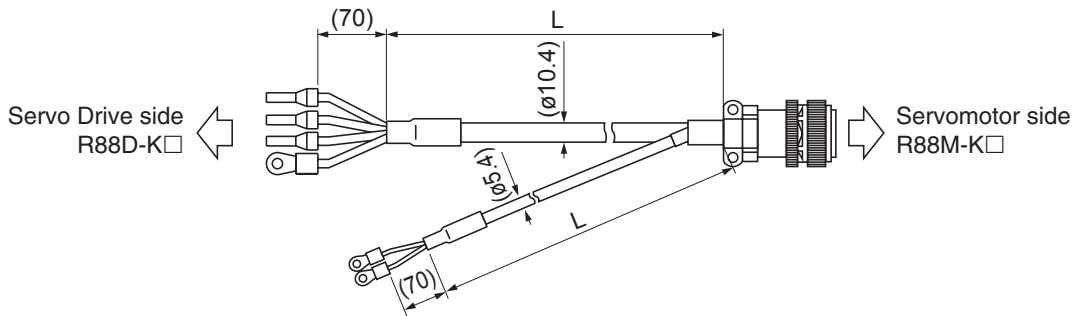

Wiring

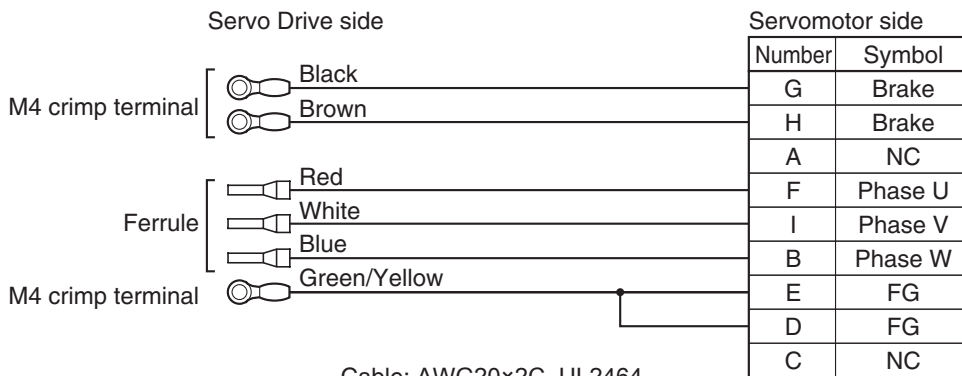

Cable: AWG20×2C UL2464
Cable: AWG14×4C UL2463

[Servomotor side connector]

Straight plug model

N/MS3106B20-18S (Japan Aviation Electronics)

Cable clamp model

N/MS3057-12A (Japan Aviation Electronics)

● **R88A-CAKF□B**

Cable types

400 V:

(For 3,000-r/min Servomotors of 750 W to 2 kW, 2,000-r/min Servomotors of 400 W to 2 kW, 1,000-r/min Servomotors of 900 W)

Model	Length (L)	Outer diameter of sheath	Weight
R88A-CAKF003B	3 m	ø10.4/ø5.4	Approx. 0.9 kg
R88A-CAKF005B	5 m		Approx. 1.3 kg
R88A-CAKF010B	10 m		Approx. 2.4 kg
R88A-CAKF015B	15 m		Approx. 3.6 kg
R88A-CAKF020B	20 m		Approx. 4.7 kg
R88A-CAKF030B	30 m		Approx. 6.9 kg
R88A-CAKF040B	40 m		Approx. 9.1 kg
R88A-CAKF050B	50 m		Approx. 11.4 kg

Connection configuration and external dimensions

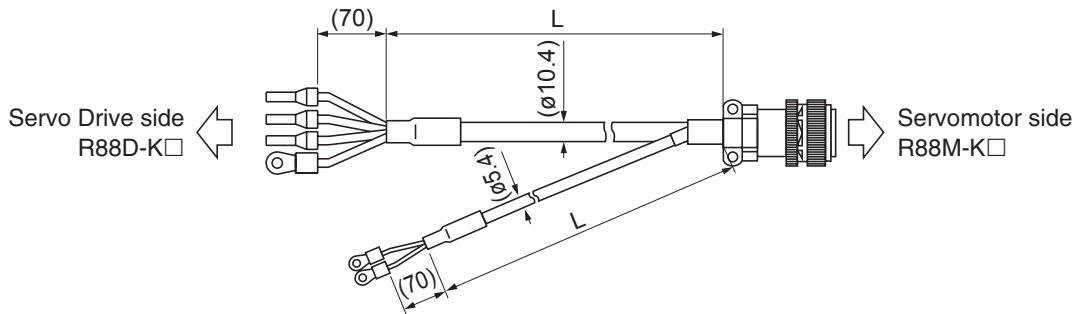

Wiring

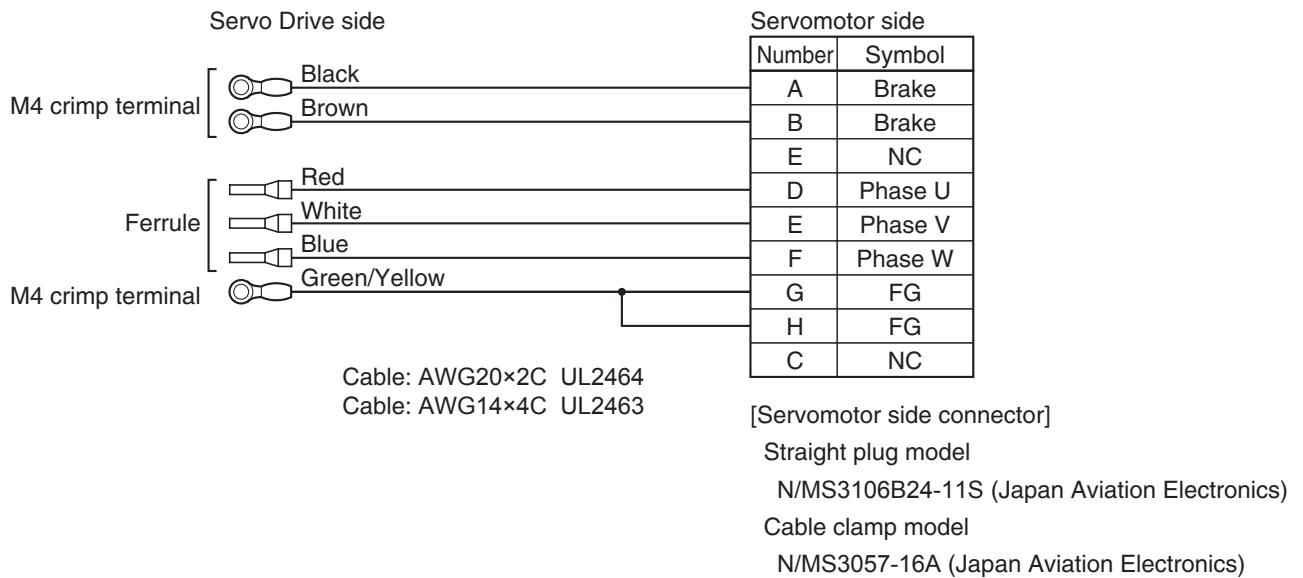

● **R88A-CAGD□B**

Cable types

(For 3,000-r/min Servomotors of 3 to 5 kW, 2,000-r/min Servomotors of 3 to 5 kW, 1,000-r/min Servomotors of 2 to 4.5 kW)

Model	Length (L)	Outer diameter of sheath	Weight
R88A-CAGD003B	3 m	ø14.7/ø5.4	Approx. 1.5 kg
R88A-CAGD005B	5 m		Approx. 2.4 kg
R88A-CAGD010B	10 m		Approx. 4.5 kg
R88A-CAGD015B	15 m		Approx. 6.7 kg
R88A-CAGD020B	20 m		Approx. 8.8 kg
R88A-CAGD030B	30 m		Approx. 13.1 kg
R88A-CAGD040B	40 m		Approx. 17.4 kg
R88A-CAGD050B	50 m		Approx. 21.8 kg

Connection configuration and external dimensions

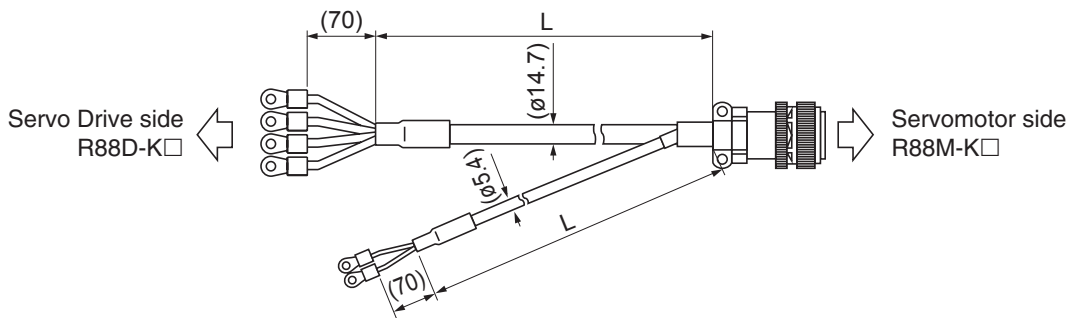

Wiring

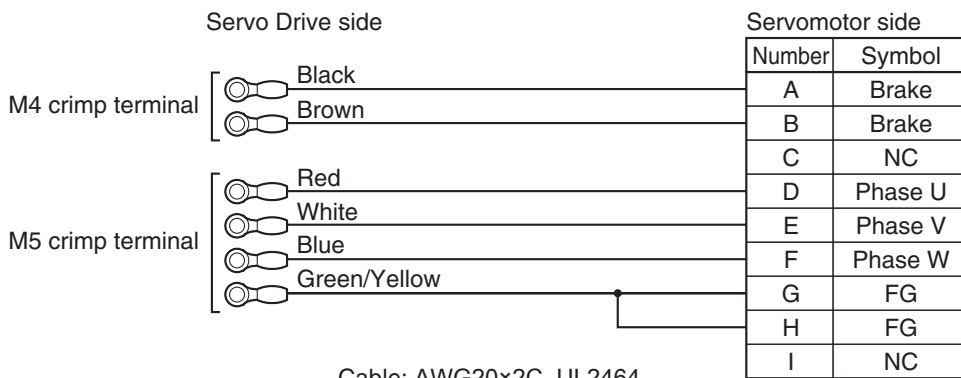

Cable: AWG20×2C UL2464
Cable: AWG10×4C UL2463

[Servomotor side connector]

Straight plug model

N/MS3106B24-11S (Japan Aviation Electronics)

Cable clamp model

N/MS3057-16A (Japan Aviation Electronics)

Power Cables with Brakes (Robot Cable)

● R88A-CAGB□BR

Cable types

200 V:

(For 3,000-r/min Servomotors of 1 to 2 kW, 2,000-r/min Servomotors of 1 to 2 kW, 1,000-r/min Servomotors of 900 W)

Model	Length (L)	Outer diameter of sheath	Minimum bending radius (R) *1	Weight
R88A-CAGB003BR	3 m	ø12.7/ø6.1	Power cable part: 90 mm Brake cable part: 45 mm	Approx. 0.9 kg
R88A-CAGB005BR	5 m			Approx. 1.5 kg
R88A-CAGB010BR	10 m			Approx. 2.8 kg
R88A-CAGB015BR	15 m			Approx. 4.2 kg
R88A-CAGB020BR	20 m			Approx. 5.5 kg
R88A-CAGB030BR	30 m			Approx. 8.2 kg
R88A-CAGB040BR	40 m			Approx. 10.9 kg
R88A-CAGB050BR	50 m			Approx. 13.6 kg

*1 For information on minimum bend radius, refer to 3-5-1 Bend Radius of Robot Cable on page 3-67.

Connection configuration and external dimensions

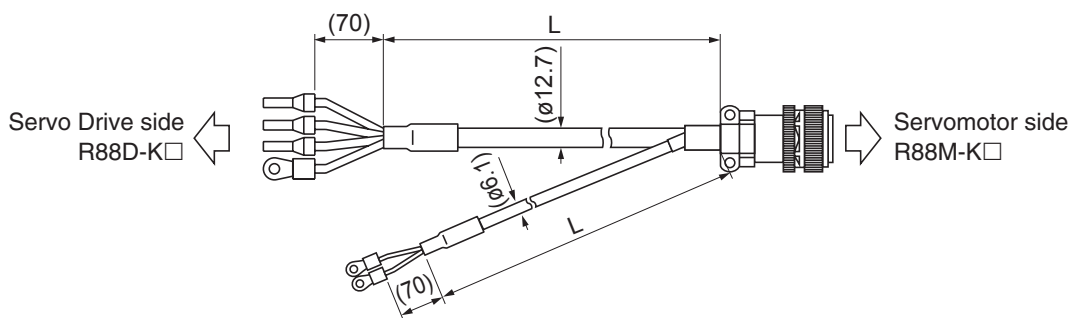

Wiring

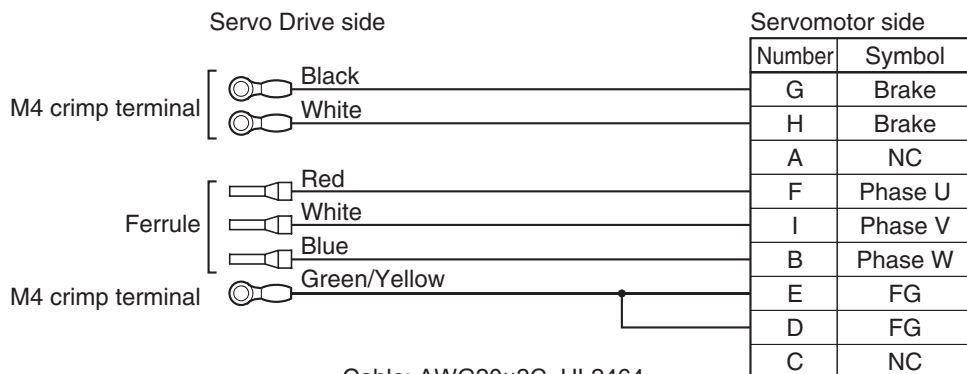

Cable: AWG20×2C UL2464
Cable: AWG14×4C UL2501

[Servomotor side connector]

Straight plug model

N/MS3106B20-18S (Japan Aviation Electronics)

Cable clamp model

N/MS3057-12A (Japan Aviation Electronics)

● **R88A-CAKF□BR**

Cable types

400 V:

(For 3,000-r/min Servomotors of 750 W to 2 kW, 2,000-r/min Servomotors of 400 W to 2 kW, 1,000-r/min Servomotors of 900 W)

Model	Length (L)	Outer diameter of sheath	Minimum bending radius (R) *1	Weight
R88A-CAKF003BR	3 m	ø12.7/ø6.1	Power cable part: 90 mm Brake cable part: 45 mm	Approx. 1.0 kg
R88A-CAKF005BR	5 m			Approx. 1.6 kg
R88A-CAKF010BR	10 m			Approx. 2.9 kg
R88A-CAKF015BR	15 m			Approx. 4.3 kg
R88A-CAKF020BR	20 m			Approx. 5.6 kg
R88A-CAKF030BR	30 m			Approx. 8.3 kg
R88A-CAKF040BR	40 m			Approx. 11.0 kg
R88A-CAKF050BR	50 m			Approx. 13.7 kg

*1 For information on minimum bend radius, refer to 3-5-1 Bend Radius of Robot Cable on page 3-67.

Connection configuration and external dimensions

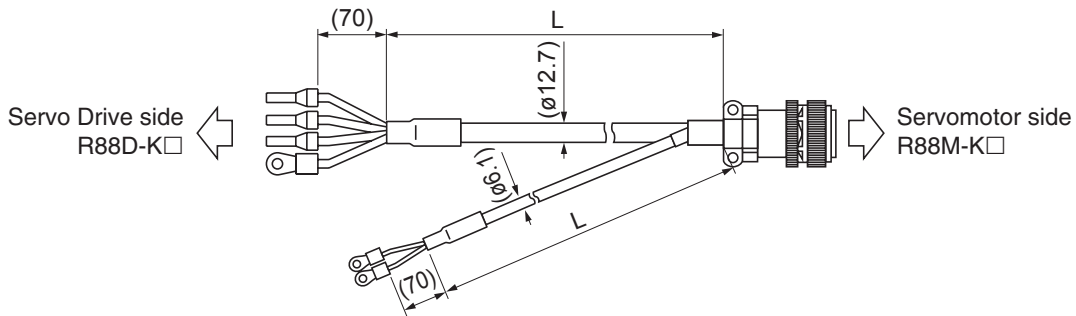

Wiring

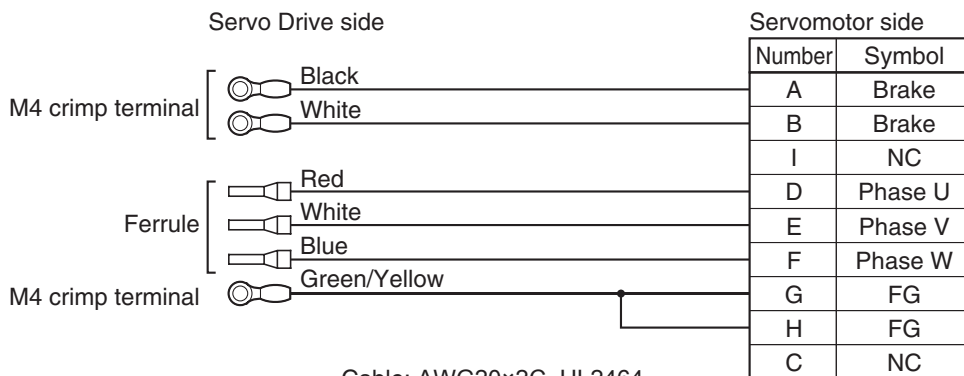

Cable: AWG20×2C UL2464
Cable: AWG14×4C UL2501

[Servomotor side connector]

Straight plug model

N/MS3106B24-11S (Japan Aviation Electronics)

Cable clamp model

N/MS3057-16A (Japan Aviation Electronics)

● **R88A-CAGD□BR**

Cable types

(For 3,000-r/min Servomotors of 3 to 5 kW, 2,000-r/min Servomotors of 3 to 5 kW, 1,000-r/min Servomotors of 2 to 4.5 kW)

Model	Length (L)	Outer diameter of sheath	Minimum bending radius (R) *1	Weight
R88A-CAGD003BR	3 m	ø15.6/ø6.1	Power cable part: 100 mm Brake cable part: 45 mm	Approx. 1.6 kg
R88A-CAGD005BR	5 m			Approx. 2.5 kg
R88A-CAGD010BR	10 m			Approx. 4.7 kg
R88A-CAGD015BR	15 m			Approx. 7.0 kg
R88A-CAGD020BR	20 m			Approx. 9.2 kg
R88A-CAGD030BR	30 m			Approx. 13.7 kg
R88A-CAGD040BR	40 m			Approx. 18.2 kg
R88A-CAGD050BR	50 m			Approx. 22.7 kg

*1 For information on minimum bend radius, refer to 3-5-1 Bend Radius of Robot Cable on page 3-67.

Connection configuration and external dimensions

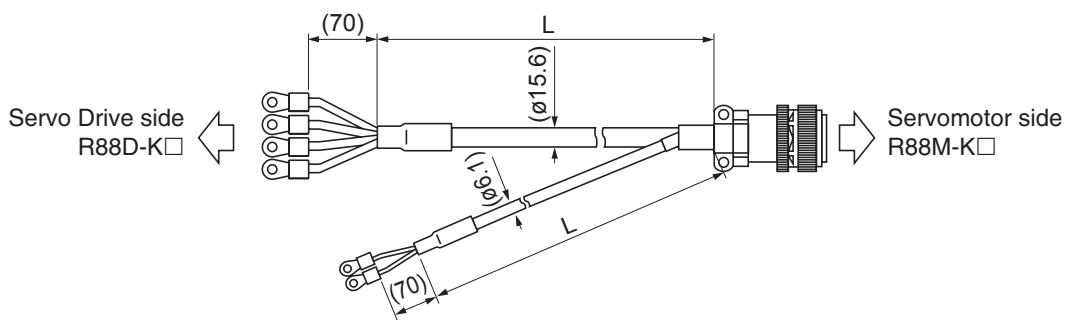

Wiring

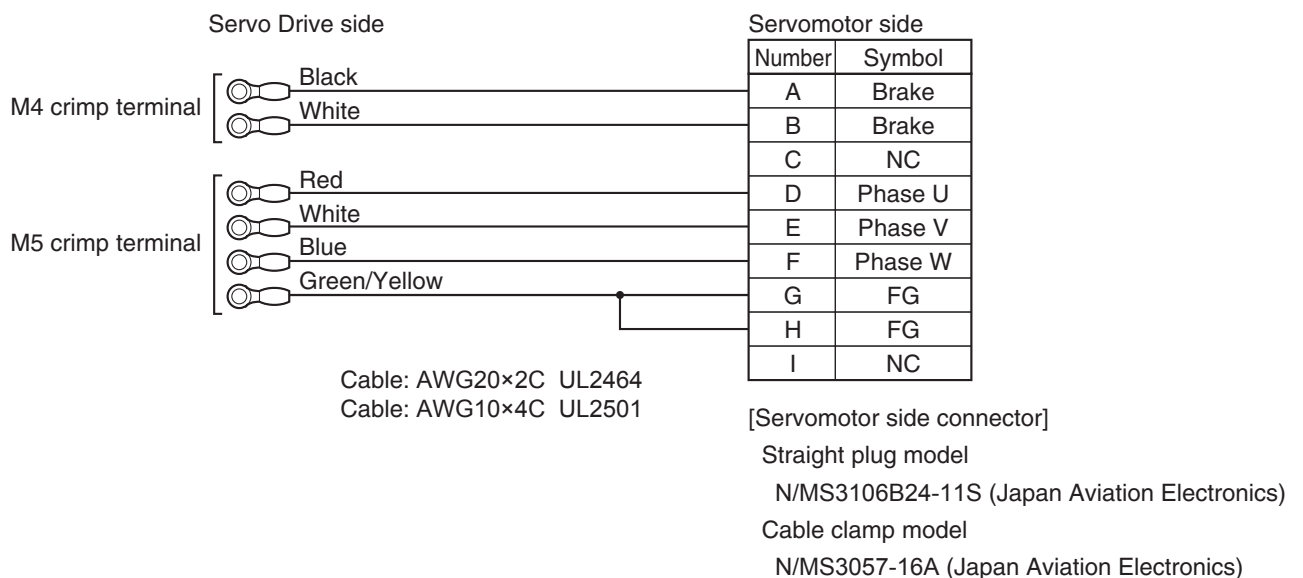

Brake Cables (Standard Cable)

● R88A-CAKA□B

Cable types

[100 V and 200 V] (For 3,000-r/min Servomotors of 50 to 750 W)

Model	Length (L)	Outer diameter of sheath	Weight
R88A-CAKA003B	3 m	ø4.4	Approx. 0.1 kg
R88A-CAKA005B	5 m		Approx. 0.1 kg
R88A-CAKA010B	10 m		Approx. 0.3 kg
R88A-CAKA015B	15 m		Approx. 0.4 kg
R88A-CAKA020B	20 m		Approx. 0.5 kg
R88A-CAKA030B	30 m	ø5.4	Approx. 1.2 kg
R88A-CAKA040B	40 m		Approx. 1.7 kg
R88A-CAKA050B	50 m		Approx. 2.1 kg

Connection configuration and external dimensions

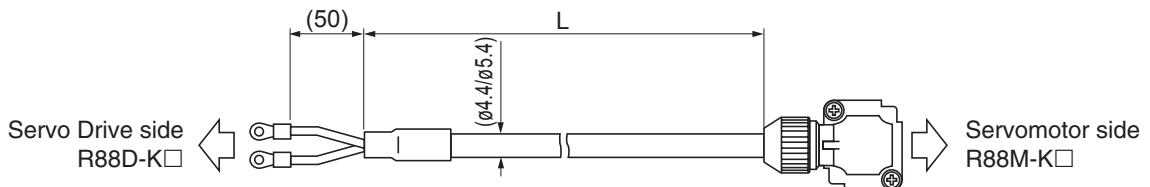

Wiring

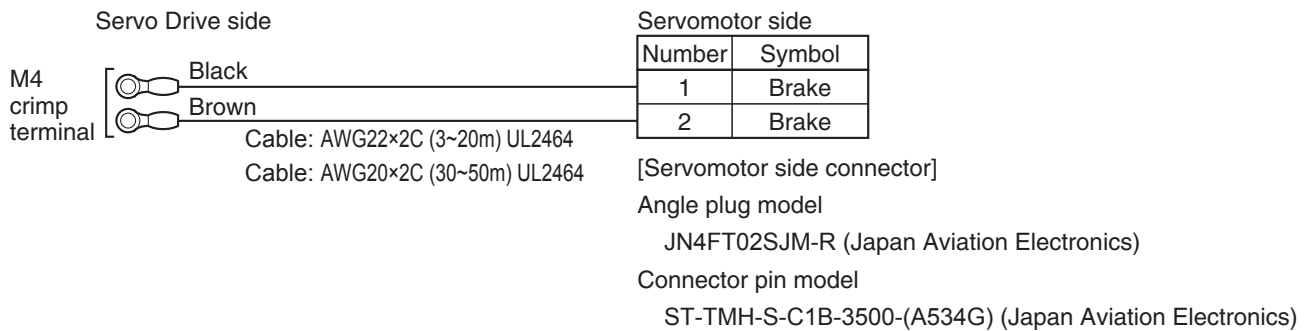

● **R88A-CAGE□B**

Cable types

(For 1,500-r/min Servomotors of 7.5 to 15 kW, 1,000-r/min Servomotors of 6 kW)

Model	Length (L)	Outer diameter of sheath	Weight
R88A-CAGE003B	3 m	ø5.4	Approx. 0.2 kg
R88A-CAGE005B	5 m		Approx. 0.3 kg
R88A-CAGE010B	10 m		Approx. 0.5 kg
R88A-CAGE015B	15 m		Approx. 0.7 kg
R88A-CAGE020B	20 m		Approx. 0.9 kg
R88A-CAGE030B	30 m		Approx. 1.3 kg
R88A-CAGE040B	40 m		Approx. 1.7 kg
R88A-CAGE050B	50 m		Approx. 2.1 kg

Connection configuration and external dimensions

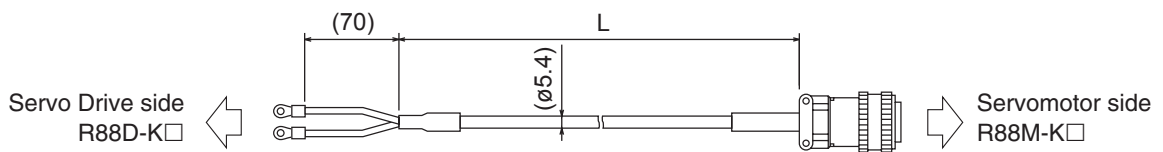

Wiring

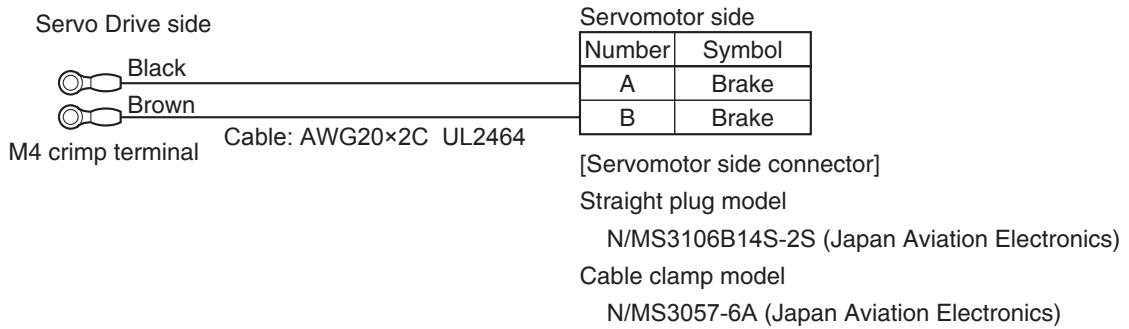

Brake Cables (Robot Cable)

● R88A-CAKA□BR

Cable types

[100 V and 200 V] (For 3,000-r/min Servomotors of 50 to 750 W)

Model	Length (L)	Outer diameter of sheath	Minimum bending radius (R) *1	Weight
R88A-CAKA003BR	3 m	ø4.4	30 mm	Approx. 0.1 kg
R88A-CAKA005BR	5 m			Approx. 0.1 kg
R88A-CAKA010BR	10 m			Approx. 0.3 kg
R88A-CAKA015BR	15 m			Approx. 0.4 kg
R88A-CAKA020BR	20 m			Approx. 0.5 kg
R88A-CAKA030BR	30 m	ø6.1	45mm	Approx. 1.3 kg
R88A-CAKA040BR	40 m			Approx. 1.8 kg
R88A-CAKA050BR	50 m			Approx. 2.2 kg

*1 For information on minimum bend radius, refer to 3-5-1 Bend Radius of Robot Cable on page 3-67.

Connection configuration and external dimensions

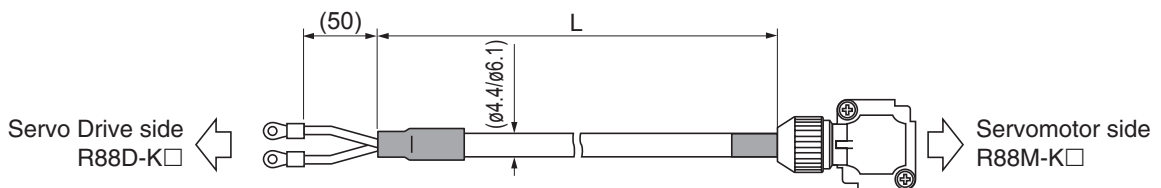

Wiring

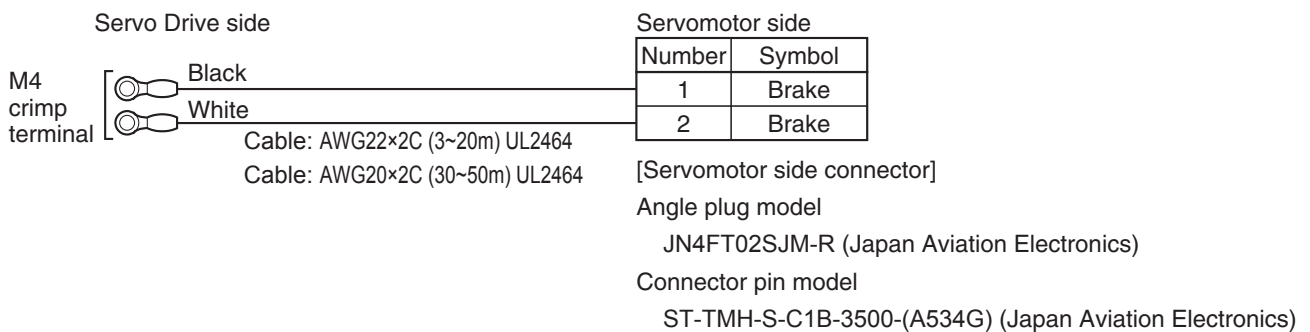

3-5-5 Connector Specifications

Control I/O Connector (R88A-CNW01C)

This is the connector to be connected to the drive's control I/O connector (CN1).

Use this connector when preparing a control cable by yourself.

● Dimensions

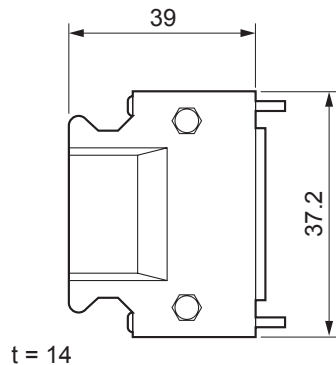

Connector plug model
10126-3000PE (Sumitomo 3M)
Connector case model
10326-52A0-008 (Sumitomo 3M)

Encoder Connectors

These connectors are used for encoder cables.

Use them when preparing an encoder cable by yourself.

● Dimensions

R88A-CNW01R (Drive's CN2 side)

This connector is soldered.

Use the following cable.

- Applicable wire: AWG16 max.
- Insulating cover outer diameter: 2.1 mm dia. max.
- Outer diameter of sheath: 6.7 ± 0.5 mm dia.

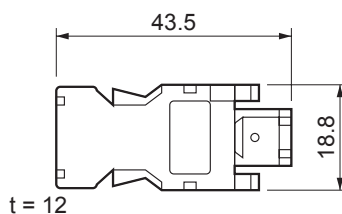

Connector plug model
55100-0670 (Molex Japan)

R88A-CNK02R (Servomotor side)

Use the following cable.

- Applicable wire: AWG22 max.
- Insulating cover outer diameter: 1.3 mm dia. max.
- Outer diameter of sheath: 5 ± 0.5 mm dia.

Applicable motors

- 100-V, 3,000-r/min Servomotors of 50 to 400 W
- 200-V, 3,000-r/min Servomotors of 50 to 750 W

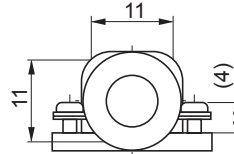
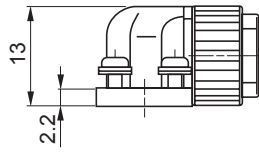
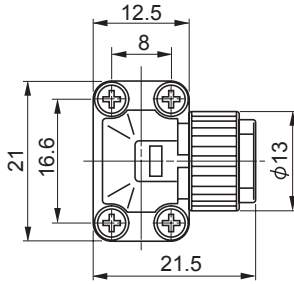

For the angle plug, cable pulling out direction can be reversed.

Angle plug model JN6FR07SM1
(Japan Aviation Electronics)

Connector pin model LY10-C1-A1-10000
(Japan Aviation Electronics)

R88A-CNK04R (Servomotor side)

Use the following cable.

- Applicable wire: AWG20 max.
- Outer diameter of sheath: 6.5 to 8.0 mm dia.

Applicable motors

- 200-V, 3,000-r/min Servomotors of all capacities
- 200-V, 2,000-r/min Servomotors of all capacities
- 200-V, 1,500-r/min Servomotors of all capacities
- 200-V, 1,000-r/min Servomotors of all capacities
- 400-V, 3,000-r/min Servomotors of all capacities
- 400-V, 2,000-r/min Servomotors of all capacities
- 400-V, 1,500-r/min Servomotors of all capacities
- 400-V, 1,000-r/min Servomotors of all capacities

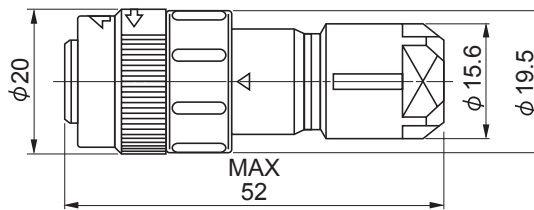
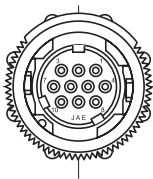

Straight plug model JN2DS10SL2-R
(Japan Aviation Electronics)

Contact model JN1-22-22S-PKG100
(Japan Aviation Electronics)

Power Cable Connector (R88A-CNK11A)

This connector is used for power cables.

Use it when preparing a power cable by yourself.

For the angle plug, cable pulling out direction can be reversed.

Note If you reverse the direction, you cannot attach the Connector to Servomotors of 50 W and 100 W.

Applicable motors

100-V, 3,000-r/min Servomotors of 50 to 400 W

200-V, 3,000-r/min Servomotors of 50 to 750 W

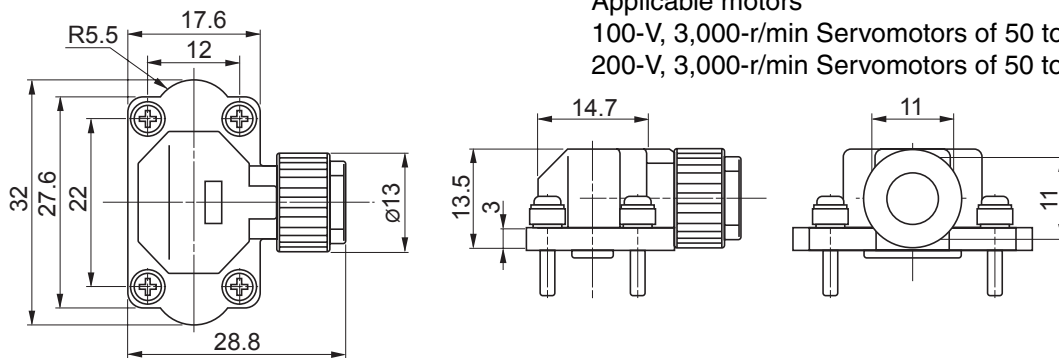

Angle plug model JN8FT04SJ1
(Japan Aviation Electronics)

Socket contact model ST-TMH-S-C1B-3500-(A534G)
(Japan Aviation Electronics)

Brake Cable Connector (R88A-CNK11B)

This connector is used for brake cables.

Use it when preparing a brake cable by yourself.

For the angle plug, cable pulling out direction can be reversed.

Applicable motors

100-V, 3,000-r/min Servomotors of 50 to 400 W

200-V, 3,000-r/min Servomotors of 50 to 750 W

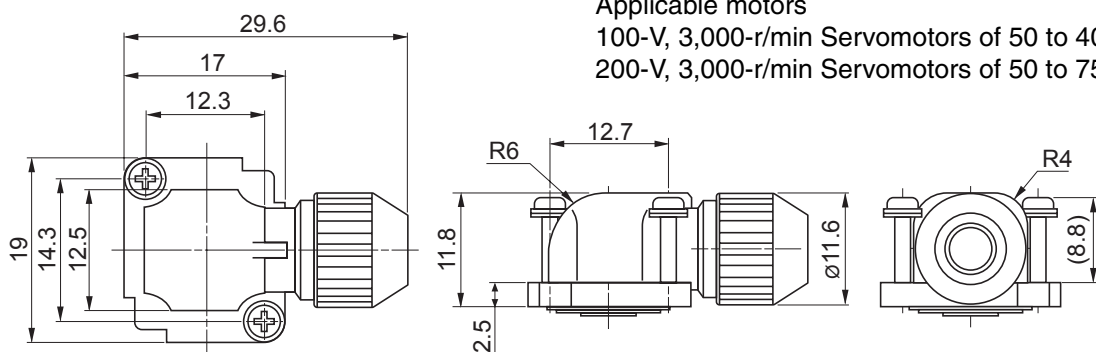

Angle plug model JN4FT02SM-R
(Japan Aviation Electronics)

Socket contact model ST-TMH-S-C1B-3500-(A534G)
(Japan Aviation Electronics)

3-5-6 EtherCAT Communications Cable Specifications

For the EtherCAT communications cable, use an Ethernet Category 5 (100BASE-TX) or higher twisted-pair cable (with double, aluminum tape and braided shielding).

Recommended cable is shown below.

Recommended Cable

Size x Number of cable cores (pairs)	Recommended manufacturer	Model
AWG24 x 4P	Tonichi kyosan Cable, Ltd.	NETSTAR-C5E SAB 0.5 x 4P
	Kuramo Electric Co.	KETH-SB
	SWCC Showa Cable Systems Co.	FAE-5004
AWG22 x 2P	Kuramo Electric Co.	KETH-PSB-OMR ^{*1}

*1 It is recommended that you use this cable in combination with the OMRON XS6G-T421-1 connector.



Precautions for Correct Use

The maximum length between nodes is 100 m. However, some cables are specified for less than 100 m. Generally speaking, if the conductors are twisted wire rather than solid wire, transmission performance will be lower, and reliable communications may not be possible at 100 m. Confirm details with the cable manufacturer.



Additional Information

If an Ethernet cable of Ethernet Category 5 (100BASE-TX) or higher is used, communications will be possible even if the cable is not shielded. However, we recommend a cable with double, aluminum tape and braided shielding to ensure sufficient noise immunity.

Recommended Connector (Modular Plug)

Use a shielded connector of Ethernet Category 5 (100BASE-TX) or higher.

Recommended connector is shown below.

Size x Number of cable cores (pairs)	Recommended manufacturer	Model	Contacts
AWG24 x 4P	Panduit Corporation	MPS588	Panduit Corporation Japan Branch Osaka Sales Office
AWG22 x 2P	OMRON Corporation	XS6G-T421-1*1	OMRON Corporation Customer Support

*1 It is recommended that you use this connector in combination with the Kuramo Electric Co. KETH-PSB-OMR cable.



Precautions for Correct Use

When selecting a connector, confirm that it is applicable to the cable that will be used. Confirm the following items: Conductor size, conductor type (solid wire or twisted wire), number of twisted pairs (2 or 4), outer diameter, etc.

Attaching the Connectors to the Cable

Use straight wiring for the communications cable, as shown below.

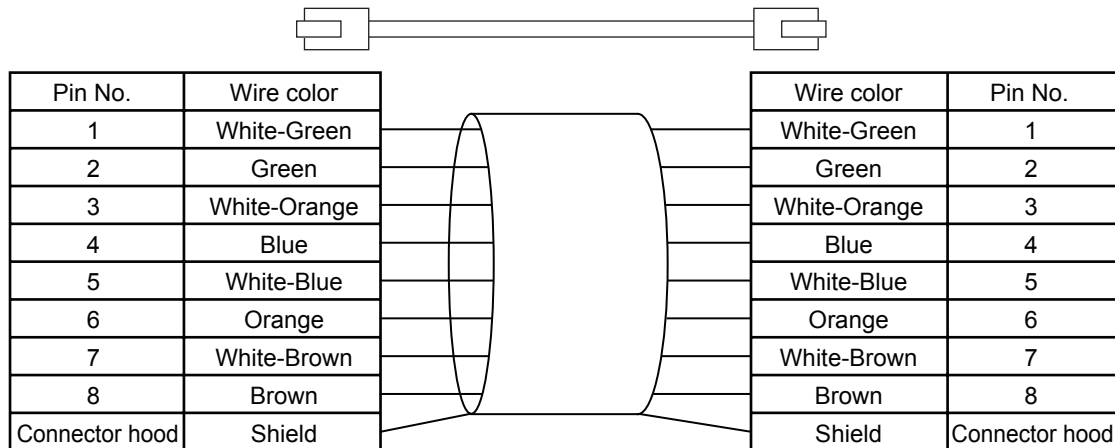

Note 1 Connect the cable shield to the connector hood at both ends of the cable.

2 There are two connection methods for Ethernet: T568A and T568B. The T568A connection method is shown above, but the T568B connection method can also be used.

Wiring

This example shows how to connect a CJ1W-NC281/NC481/NC881/NCF81/NC482/NC882 Position Control Unit to Servo Drives using EtherCAT Communications Cables.

Connect the EtherCAT master to the ECAT IN connector on the first Servo Drive. Connect the ECAT OUT connector on the first Servo Drive to the ECAT IN connector on the next Servo Drive. Do not connect the ECAT OUT connector on the last Servo Drive.

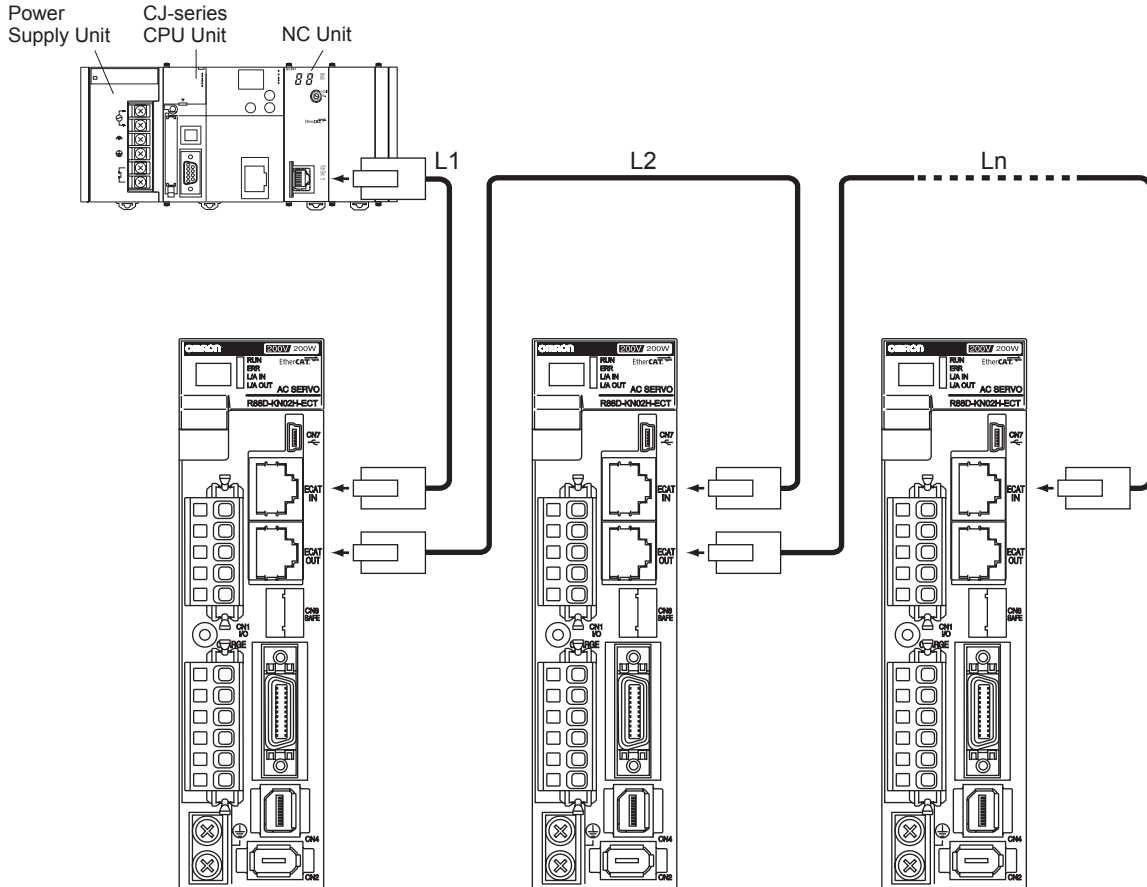

Additional Information

- Always turn OFF the power supply to the Position Control Unit and Servo Drives before connecting or disconnecting the EtherCAT Communications Cables.
- The cable between the two nodes (L1, L2 ... Ln) must be 100 m or less.

3-5-7 Analog Monitor Cable Specifications

Analog Monitor Cable (R88A-CMK001S)

- Connection Configuration and External Dimensions

Symbol	No.	
AM1	1	Red
AM2	2	White
GND	3	Black
	4	
	5	
	6	

Cable: AWG24×3C UL1007

Connector housing: 51004-0600 (Molex Japan)

Connector terminal: 50011-8000 (Molex Japan)

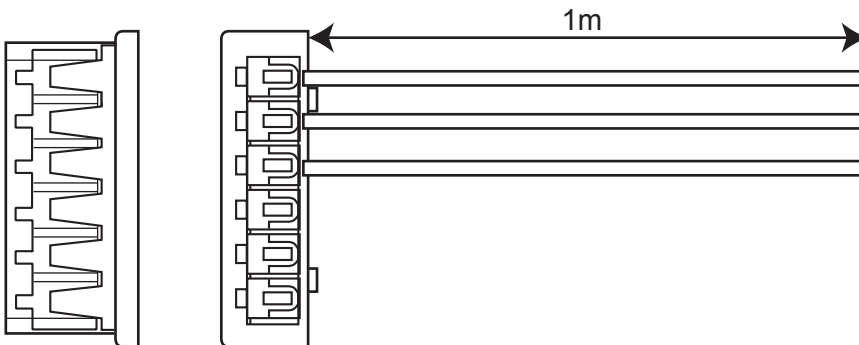

External Encoder Connector (R88A-CNK41L)

Use this connector to connect to an external encoder in fully-closed control.

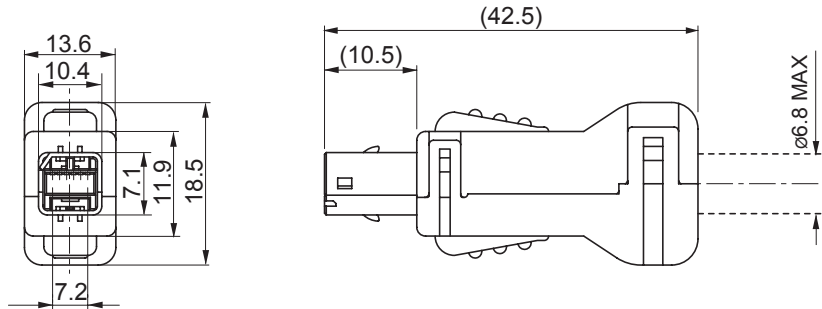

Connector plug model

MUF-PK10K-X (J.S.T. Mfg. Co., Ltd.)

● Pin Arrangement

View from Inserted Portion

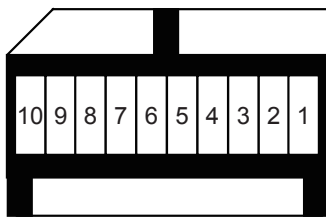

View from Soldered Housing Surface

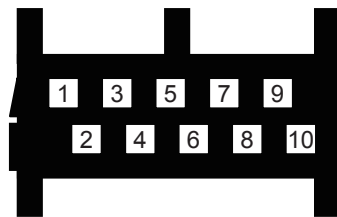

Safety I/O Signal Connector (R88A-CNK81S)

Use this connector to connect to a safety device.

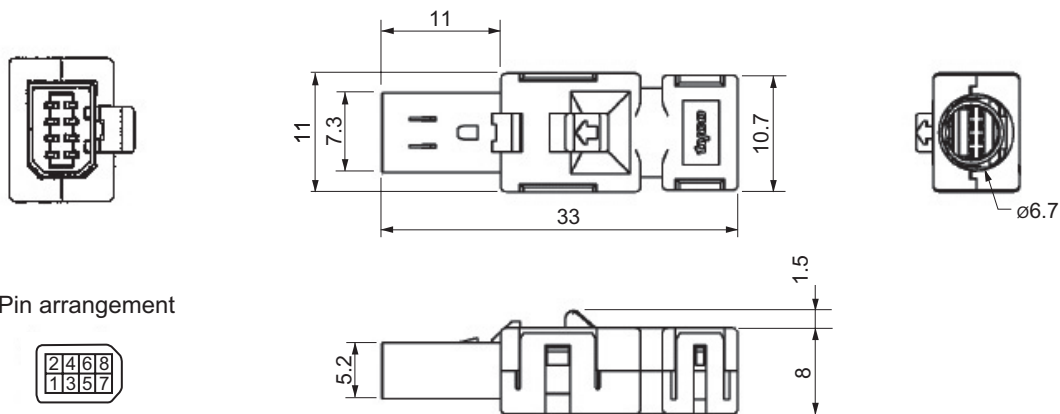

Pin arrangement

Note The recommended cable is a 6-core shielded cable with a wire size of AWG30 to AWG26 and a finished outer diameter of 6.7 mm or less.

Note For information on wiring, refer to *Safety Connector Specifications (CN8)* on page 3-33.

3-5-8 Control Cable Specifications

Cables for Servo Drives (XW2Z-□J-B34)

These cables connect to the connector terminal blocks on G5-series Servo Drives with Built-in EtherCAT Communications.

● Cable Models

Model	Length (L)	Outer diameter of sheath	Weight
XW2Z-100J-B34	1 m	8.8 dia.	Approx. 0.1 kg
XW2Z-200J-B34	2 m		Approx. 0.2 kg

● Connection Configuration and Dimensions

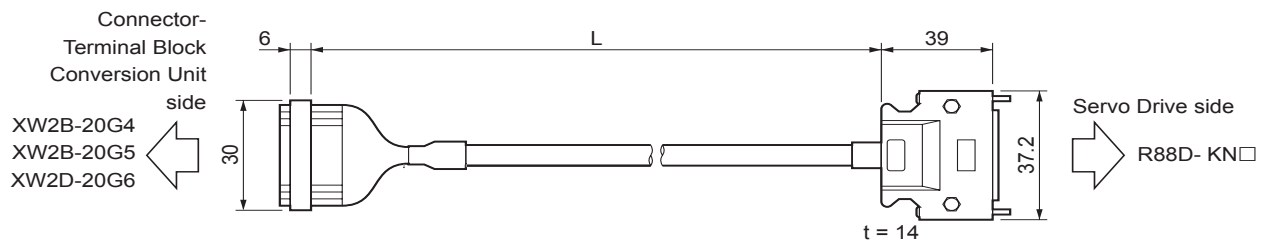

● Wiring

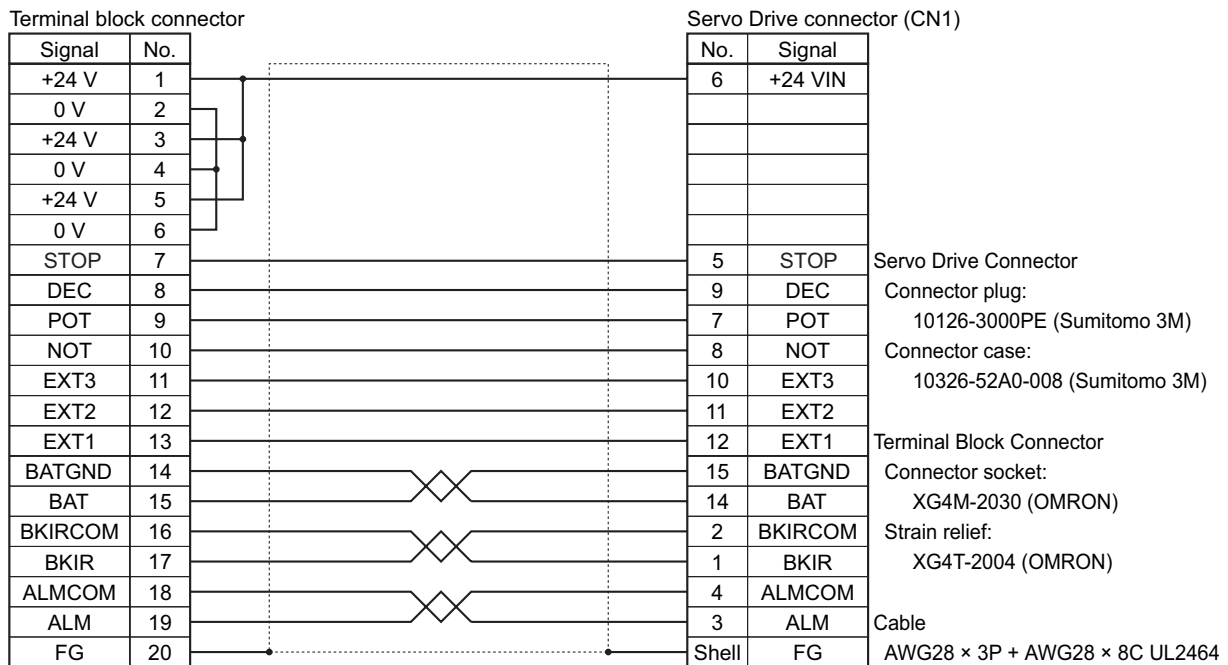

* Before you use the Servo Drive, confirm that the signals of Servo Drive connector are set as shown above.

Connector-Terminal Block Conversion Unit (XW2B-20G□)

The Unit is used with a Connector Terminal Block Cable (XW2Z-□J-B34). They convert the control input signal (CN1) of the G5-series Servo Drive into a terminal block.

● Terminal Block Models

Model	Description
XW2B-20G4	M3 screw terminal block
XW2B-20G5	M3.5 screw terminal block
XW2D-20G6	M3 screw terminal block

● XW2B-20G4

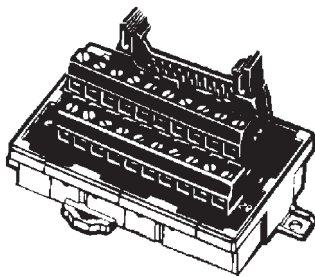

Dimensions

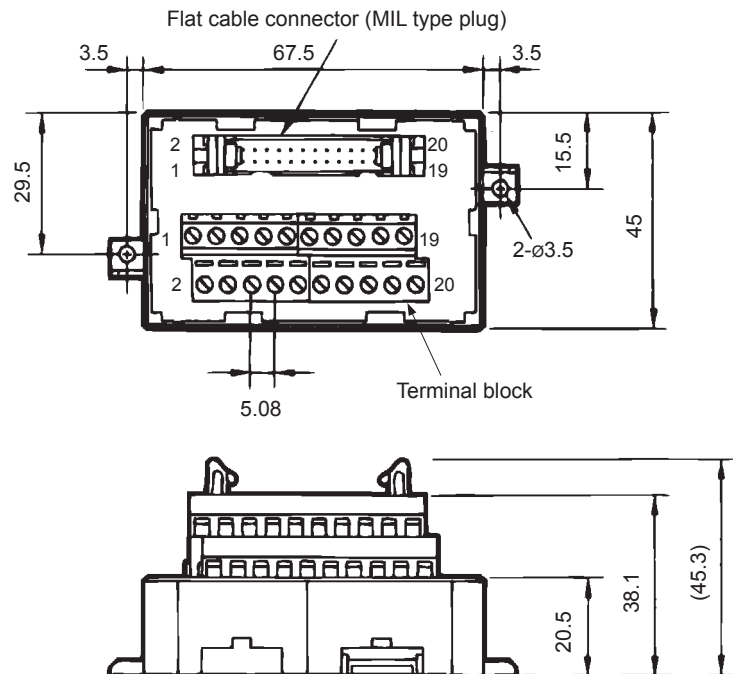

Precautions for Correct Use

- Use 0.3 to 1.25 mm² wire (AWG22 to 16).
- The wire inlet of M3 screw terminal block is 1.8 mm (height) × 2.5 mm (width).
- Strip the insulation from the end of the wire for 6 mm as shown below.

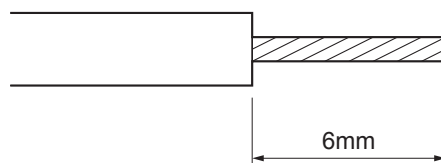

● XW2B-20G5

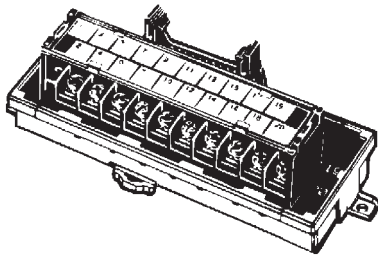

Dimensions

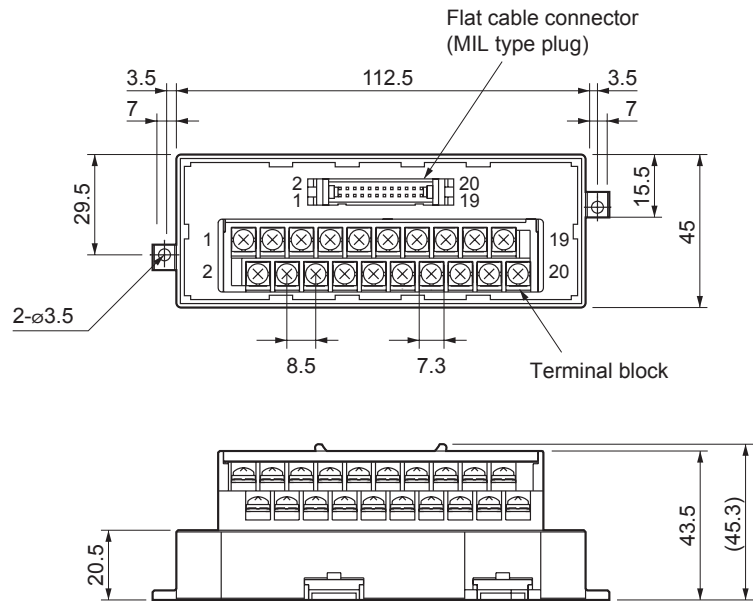

Note The pitch of terminals is 8.5 mm.



Precautions for Correct Use

- When using crimp terminals, use crimp terminals with the following dimensions.

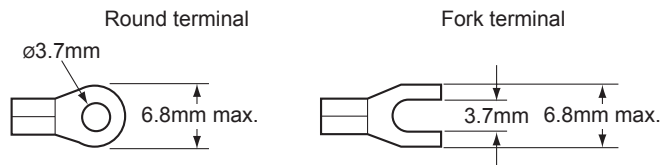

Applicable crimp terminals		Applicable wires
Round terminals	1.25 to 3	AWG22 to 16 (0.30 to 1.25 mm ²)
	2 to 3.5	AWG16 to 14 (1.25 to 2.0 mm ²)
Fork terminals	1.25Y to 3	AWG22 to 16 (0.30 to 1.25 mm ²)
	2 to 3.5	AWG16 to 14 (1.25 to 2.0 mm ²)

- When connecting wires and crimp terminals to a terminal block, tighten them to a tightening torque of 0.59 N·m.

● XW2D-20G6

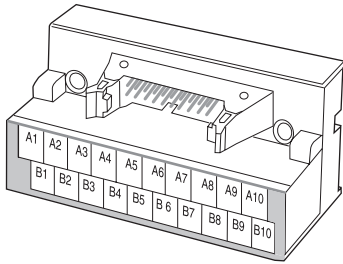

Dimensions

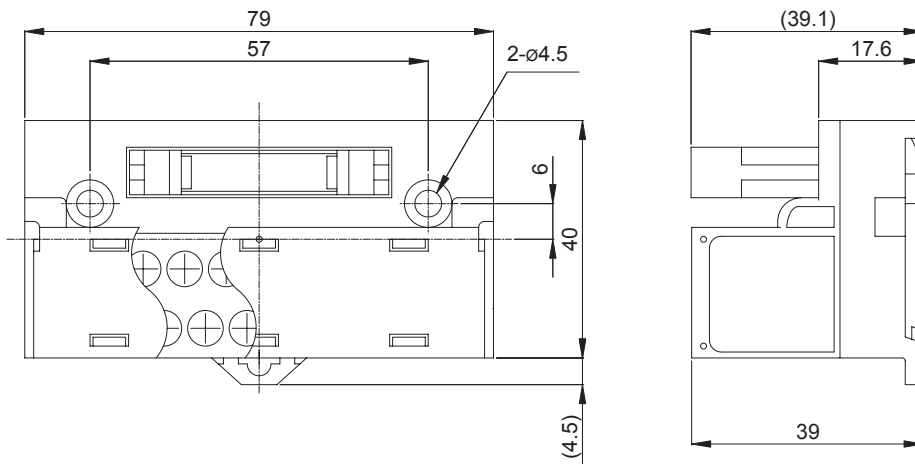

Precautions for Correct Use

- When using crimp terminals, use crimp terminals with the following dimensions.

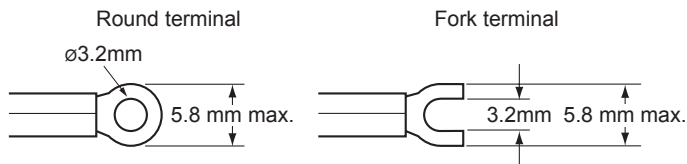

Applicable crimp terminals		Applicable wires
Round terminals	1.25 to 3	AWG22 to 16 (0.30 to 1.25 mm ²)
Fork terminals	1.25Y to 3	AWG22 to 16 (0.30 to 1.25mm ²)

- When connecting wires and crimp terminals to a terminal block, tighten them to a tightening torque of 0.7 N·m.

Terminal Block Wiring Example

The example is for the XW2B-20G4, XW2B-20G5, and XW2D-20G6.

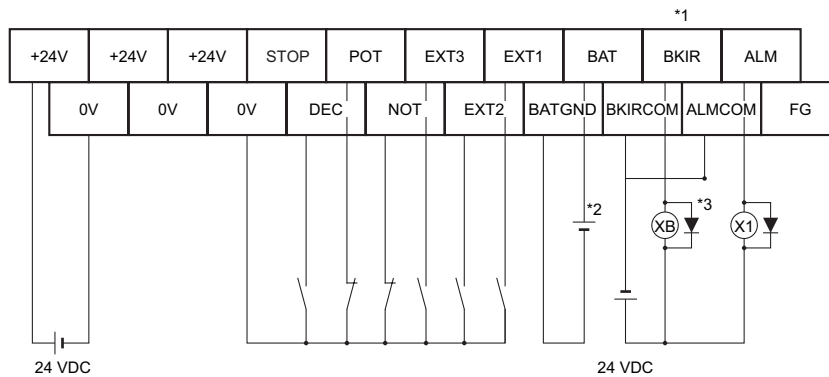

*1 Assign the brake interlock output (BKIR) to pin CN1-1.

*2 This is the absolute encoder backup battery of 2.8 to 4.5 V. Secure the battery in place using cable clips with double-sided adhesive tape. Connect the battery to either the connector terminal block or the absolute encoder backup battery cable (with a battery). The absolute encoder backup battery is not required when the Servomotor is equipped with an incremental encoder.

*3 The XB contact is used to turn ON/OFF the electromagnetic brake.

3-6 External Regeneration Resistor Specifications

3-6-1 External Regeneration Resistor Specifications

R88A-RR08050S

Model	Resistance value	Nominal capacity	Regeneration absorption for 120°C temperature rise	Heat radiation condition	Thermal switch output specifications
R88A-RR08050S	50 Ω	80 W	20 W	Aluminum 350 × 350, Thickness: 3.0	Operating temperature: 150°C ± 5% NC contact Rated output (resistive load) 125 VAC, 0.1 A max. 30 VDC, 0.1 A max. (minimum current: 1 mA)

R88A-RR080100S

Model	Resistance value	Nominal capacity	Regeneration absorption for 120°C temperature rise	Heat radiation condition	Thermal switch output specifications
R88A-RR080100S	100 Ω	80 W	20 W	Aluminum 350 × 350, Thickness: 3.0	Operating temperature: 150°C ± 5% NC contact Rated output (resistive load) 125 VAC, 0.1 A max. 30 VDC, 0.1 A max. (minimum current: 1 mA)

R88A-RR22047S1

Model	Resistance value	Nominal capacity	Regeneration absorption for 120°C temperature rise	Heat radiation condition	Thermal switch output specifications
R88A-RR22047S1	47 Ω	220 W	70 W	Aluminum 350 × 350, Thickness: 3.0	Operating temperature: 150°C ± 5% NC contact Rated output (resistive load) 250 VAC, 0.2 A max. 42 VDC, 0.2 A max. (minimum current: 1 mA)

R88A-RR50020S

Model	Resistance value	Nominal capacity	Regeneration absorption for 120°C temperature rise	Heat radiation condition	Thermal switch output specifications
R88A-RR50020S	20 Ω	500 W	180 W	Aluminum 600 × 600, Thickness: 3.0	Operating temperature: 200°C ± 7°C NC contact Rated output (resistive load): 250 VAC, 0.2 A max. 42 VDC, 0.2 A max. (minimum current: 1 mA)

3-7 Reactor Specifications

Connect to the servo drive for Reduction of Harmonic Emission. Select the model by the servo drive model.

3-7-1 Specifications

Servo Drive		Reactor				
Model	Number of power phases	Model	Rated current	Inductance	Weight	
R88D-K□A5L-□	Single-phase	3G3AX-DL2002	1.6 A	21.4 mH	Approx. 0.8 kg	
R88D-K□01L-□		3G3AX-DL2004	3.2 A	10.7 mH	Approx. 1.0 kg	
R88D-K□02L-□		3G3AX-DL2007	6.1 A	6.75 mH	Approx. 1.3 kg	
R88D-K□04L-□		3G3AX-DL2015	9.3 A	3.51 mH	Approx. 1.6 kg	
R88D-K□01H-□	Single-phase	3G3AX-DL2002	1.6 A	21.4 mH	Approx. 0.8 kg	
	Three-phase	3G3AX-AL2025	10.0 A	2.8 mH	Approx. 2.8 kg	
R88D-K□02H-□	Single-phase	3G3AX-DL2004	3.2 A	10.7 mH	Approx. 1.0 kg	
	Three-phase	3G3AX-AL2025	10.0 A	2.8 mH	Approx. 2.8 kg	
R88D-K□04H-□	Single-phase	3G3AX-DL2007	6.1 A	6.75 mH	Approx. 1.3 kg	
	Three-phase	3G3AX-AL2025	10.0 A	2.8 mH	Approx. 2.8 kg	
R88D-K□08H-□	Single-phase	3G3AX-DL2015	9.3 A	3.51 mH	Approx. 1.6 kg	
	Three-phase	3G3AX-AL2025	10.0 A	2.8 mH	Approx. 2.8 kg	
R88D-K□10H-□	Single-phase	3G3AX-DL2015	9.3 A	3.51 mH	Approx. 1.6 kg	
	Three-phase	3G3AX-AL2025	10.0 A	2.8 mH	Approx. 2.8 kg	
R88D-K□15H-□	Single-phase	3G3AX-DL2022	13.8 A	2.51 mH	Approx. 2.1 kg	
	Three-phase	3G3AX-AL2025	10.0 A	2.8 mH	Approx. 2.8 kg	
R88D-K□20H-□	Three-phase	3G3AX-AL2055	20.0 A	0.88 mH	Approx. 4.0 kg	
R88D-K□30H-□						
R88D-K□50H-□			3G3AX-AL2110	37.0 A	0.35 mH	Approx. 5.0 kg
R88D-K□75H-□			3G3AX-AL2220	70.0 A	0.18 mH	Approx. 10.0 kg
R88D-K□150H-□						
R88D-K□06F-□			3G3AX-AL4025	6.0 A	7.7 mH	Approx. 2.7 kg
R88D-K□10F-□						
R88D-K□15F-□						
R88D-K□20F-□			3G3AX-AL4055	10.0 A	3.5 mH	Approx. 4.0 kg
R88D-K□30F-□						
R88D-K□50F-□			3G3AX-AL4110	20.0 A	1.3 mH	Approx. 6.0 kg
R88D-K□75F-□			3G3AX-AL4220	36.0 A	0.74 mH	Approx. 10.0 kg
R88D-K□150F-□						

4

System Design

This chapter explains the installation conditions, wiring methods (including wiring conforming to EMC Directives), and regenerative energy calculation methods for the Servo Drive and Servomotor. It also explains the performance of External Regeneration Resistors.

4-1	Installation Conditions	4-2
4-1-1	Servo Drive Installation Conditions	4-2
4-1-2	Servomotor Installation Conditions	4-3
4-1-3	Decelerator Installation Conditions	4-6
4-2	Wiring	4-10
4-2-1	Power Cables for 1,500-r/min Servomotors	4-10
4-2-2	Peripheral Equipment Connection Examples	4-11
4-2-3	Main Circuit and Motor Connections	4-21
4-3	Wiring Conforming to EMC Directives	4-35
4-3-1	Wiring Method	4-35
4-3-2	Selecting Connection Component	4-44
4-4	Regenerative Energy Absorption	4-56
4-4-1	Calculating the Regenerative Energy	4-56
4-4-2	Servo Drive Regeneration Absorption Capacity	4-58
4-4-3	Regenerative Energy Absorption with an External Regeneration Resistor	4-59
4-4-4	Connecting an External Regeneration Resistor	4-60
4-5	Using DC Power Input	4-63
4-5-1	Connection Example for Using DC power Input	4-64

4-1 Installation Conditions

4-1-1 Servo Drive Installation Conditions

Space Conditions around Servo Drives

- Install the Servo Drives according to the dimensions shown in the following illustration to ensure proper dispersion of heat from inside the drives and convection inside the panel. If the drives are installed side by side, install a fan for air circulation to prevent uneven temperatures inside the panel.

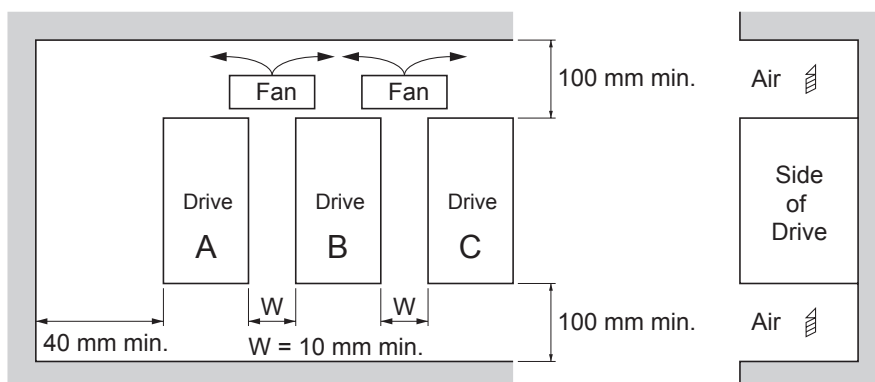

- However, W is 50 mm min. when a Servo Drive of 7.5 kW or 15 kW is installed.
- Drives of 100 V or 200 V with a capacity of 750 W max. can be installed side by side with a 1-mm clearance (W in above illustration).
- To provide electrical conduction, remove any paint from the surface on which you are installing G5-series Servo Drives. Also, it is recommended that you apply conductive plating if you are making the mounting bracket yourself.

Mounting Direction

- Mount the drive perpendicular on the panel so that the model number reads normally.

Environment Operating Conditions

- The environment in which drives are operated must meet the following conditions. Drives may malfunction if operated under any other conditions.

Ambient operating temperature: 0 to 55°C (Take into account the following temperature rises in the individual drives themselves.)

Operating humidity: 90% max. (with no condensation)

Operating atmosphere: No corrosive gases.

Altitude: 1,000 m max.

- For Drives of 100 V or 200 V with a capacity of 750 W max., the specifications for operating ambient temperature depend on the Drive (A, B, and C) when the clearance between Drives is 1 mm.

Drive A: 0 to 50°C

Drive B: 0 to 40°C

Drive C: 0 to 45°C

Ambient Temperature Control

- Operation in an environment in which there is minimal temperature rise is recommended to maintain a high level of reliability.
- When the drive is installed in a closed space, such as a box, the ambient temperature may rise due to temperature rise in each unit. Use a fan or air conditioner to prevent the drive's ambient temperature from exceeding 55°C.
- Drive surface temperatures may rise to as much as 30°C above the ambient temperature. Use heat-resistant materials for wiring, and provide a distance from any devices or wiring that are sensitive to heat.
- The service life of a Servo Drive is largely determined by the ambient temperature around the internal electrolytic capacitors. When an electrolytic capacitor reaches its limit, electrostatic capacity drops and internal resistance increases. This leads to overvoltage errors, malfunctioning due to noise, and damage to individual elements.
- If a drive is always operated at the ambient temperature of 55°C and with a 100% output of the rated torque and rated rotation speed, its life is expected to be approx. 28,000 hours (excluding the axial-flow fan). A drop of 10°C in the ambient temperature will double the expected life of the drive.

Keeping Foreign Objects Out of Units

- Place a cover over the drive or take other preventative measures to prevent foreign objects, such as drill filings, from getting into the drive during installation. Be sure to remove the cover after installation is complete. If the cover is left on during operation, drive's heat dissipation is blocked, which may result in malfunction.
- Take measures during installation and operation to prevent foreign objects such as metal particles, oil, machining oil, dust, or water from getting inside of the drives.

4-1-2 Servomotor Installation Conditions

Environment Operating Conditions

- The environment in which the motor is operated must meet the following conditions. Operating the motor outside of the following ranges may result in malfunction of the motor.

Ambient operating temperature: 0 to 40°C*¹

Operating humidity: 85% max. (with no condensation)

Operating atmosphere: No corrosive gases.

*1 The ambient operating temperature is the temperature at a point 50 mm from the motor.

Impact and Load

- The motor is resistant to impacts of up to 98 m/s². Do not apply heavy impacts or loads during transport, installation, or removal of the motor.
- When transporting the motor, hold the motor body itself. And do not hold the encoder, cable, or connector areas. Failure to follow this guideline may result in damaging the motor.
- Always use a pulley remover to remove pulleys, couplings, or other objects from the shaft.
- After assembly, secure cables so that there is no impact or load placed on the cable outlet.

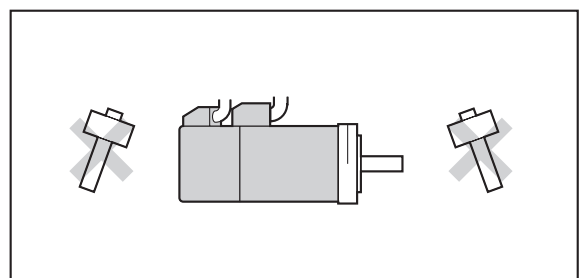

Connecting to Mechanical Systems

- For the allowable axial loads for motors, refer to *3-1-2 Characteristics* on page 3-3. If an axial load greater than that specified is applied to a motor, it may reduce the limit of the motor bearings and may break the motor shaft.
- When connecting to a load, use couplings that can sufficiently absorb mechanical eccentricity and declination.
- For spur gears, an extremely large radial load may be applied depending on the gear precision. Use spur gears with a high degree of precision (for example, JIS class 2: normal line pitch error of 6 μm max. for a pitch circle diameter of 50 mm).
- If the gear precision is not adequate, allow backlash to ensure that no radial load is placed on the motor shaft.
- When using bevel gears, a load is applied in the thrust direction depending on the structural precision, the gear precision, and temperature changes. Provide appropriate backlash or take other measures to ensure that a thrust load larger than the specified level is not applied.
- Do not put rubber packing on the flange surface. If the flange is mounted with rubber packing, the motor flange may crack under the tightening force.
- When connecting to a V-belt or timing belt, consult the manufacturer for belt selection and tension.
- A radial load twice as large as the belt tension will be placed on the motor shaft. Do not allow a load that exceeds the allowable radial load to be placed on the motor shaft. If an excessive radial load is applied, the motor shaft and bearings may be damaged.
- Set up a movable pulley in the middle of the motor shaft and the load shaft so that the belt tension can be adjusted.

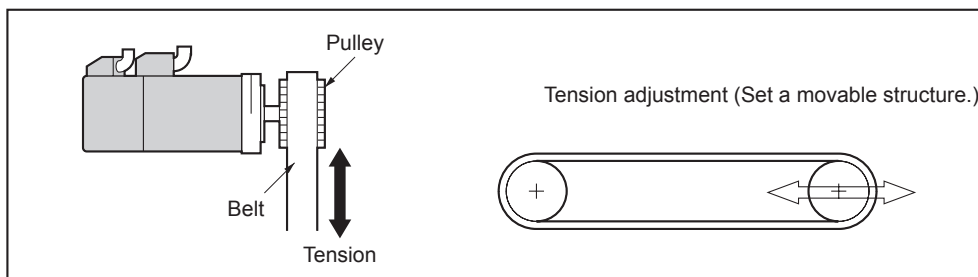
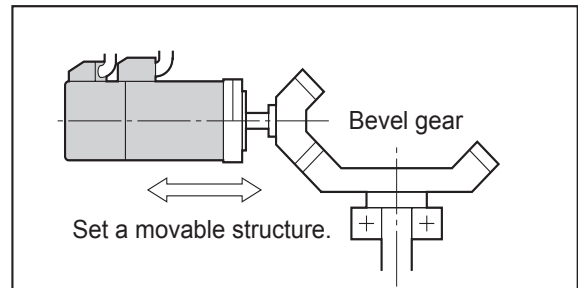
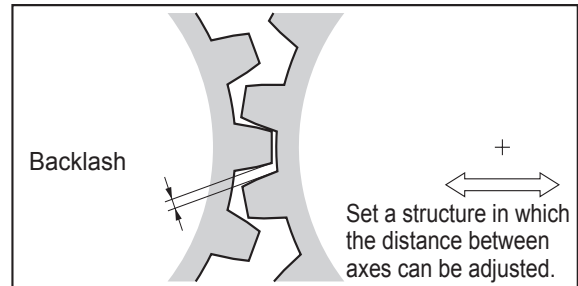
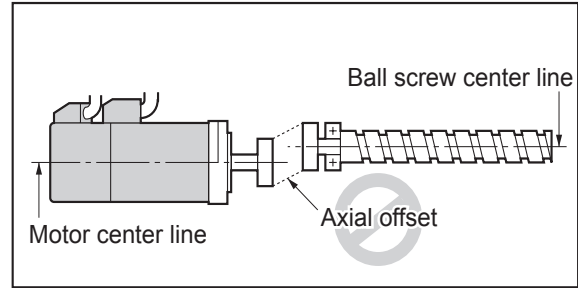

Water and Drip Resistance

- The protective structure for the motors is as follows:
Equivalent to IP67 (except for through-shaft parts and motor connector pins and encoder connector pins)

Oil-water Measures

Use the Servomotor with an oil seal if you are using it in an environment where oil drops can adhere to the through-shaft part. The operating conditions of the Servomotor with an oil seal are as follows:

- Keep the oil level below the lip of the oil seal.
- Prepare a good lubricated condition under which only oil droplets splash on the oil seal.
- If you are using the Servomotor with the shaft in upward direction, make sure that no oil accumulates on the lip of the oil seal.

Radiator Plate Installation Conditions

- When you mount a Servomotor onto a small device, be sure to provide enough radiation space on the mounting area. Otherwise the Servomotor temperature rises too high. One of the preventive measures is to install a radiator plate between the motor attachment area and the motor flange. (See below) Refer to *3-3 Servomotor Specifications* on page 3-36 for the radiator plate specifications.

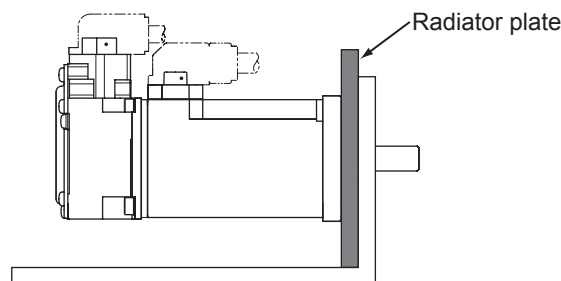

- The temperature rise depends on the mounting part materials and the installation environment. Check the actual temperature rise by using a real Servomotor.
- Depending on the environment, such as when the Servomotor is installed near a heating element, the Servomotor temperature may rise significantly. In this case, take any of the following measures.
 - Lower the load ratio.
 - Review the heat radiation conditions of the Servomotor.
 - Install a cooling fan and apply forced air cooling to the Servomotor.

Other Precautions

- Take measures to protect the motor shaft from corrosion. The motor shaft is coated with anti-corrosion oil when shipped, but anti-corrosion oil or grease should also be applied when connecting the components that apply load to the shaft.

 Caution	
	Do not apply a commercial power supply directly to the motor. Failure to follow this guideline may result in fires.
	Never repair the product by disassembling it. Failure to follow this guideline may result in electric shock or injury.

4-1-3 Decelerator Installation Conditions

Installing the Reduction Gear

● Installing the R88G-HPG □□□ (3 Arcminutes type)

Follow the instructions bellow for installing this Reduction Gear and the Servomotor.

- 1** Fit the bolt head of the shaft fixing bolt to the rubber cap by turning the input coupling.
- 2** Apply the sealant on the side which the Servomotor is installed. (Recommended sealant: Loctite 515)
- 3** Gently insert the Servomotor into the reduction gear.

Put up the reduction gear vertically and let it slide into the input shaft coupling, so as not to fall, using the motor shaft as guide, as shown in the diagram on next page. When the reduction gear cannot be put up vertically, take care not to install the motor tilted by such as tightening a bolt uniformly.

- 4** Fix the Servomotor and the flange of the reduction gear with bolts.

Bolt tightening torque (for aluminum)

Size of the hexagon socket head cap screw	M4	M5	M6	M8	M10	M12
Tightening torque (N·m)	3.2	6.3	10.7	26.1	51.5	89.9

- 5** Tighten the bolts of the input coupling.

Bolt tightening torque (for duralumin)

Size of the hexagon socket head cap screw	M4	M5	M6	M8	M10	M12
Tightening torque (N·m)	2.0	4.5	15.3	37.2	73.5	128

Note Tighten the bolts using the torque indicated on the above table. The problem such as slipping may occur when using the other unspecified torque.

2 screws have to be used as set screws when installing the R88G-HPG11B □.

Size of the hexagon socket head cap screw	M3
Tightening torque (N·m)	0.69

- 6** Mount the rubber cap to complete the installation.

(Mount 2 gasketed screws when installing the R88G-HPG11B □.)

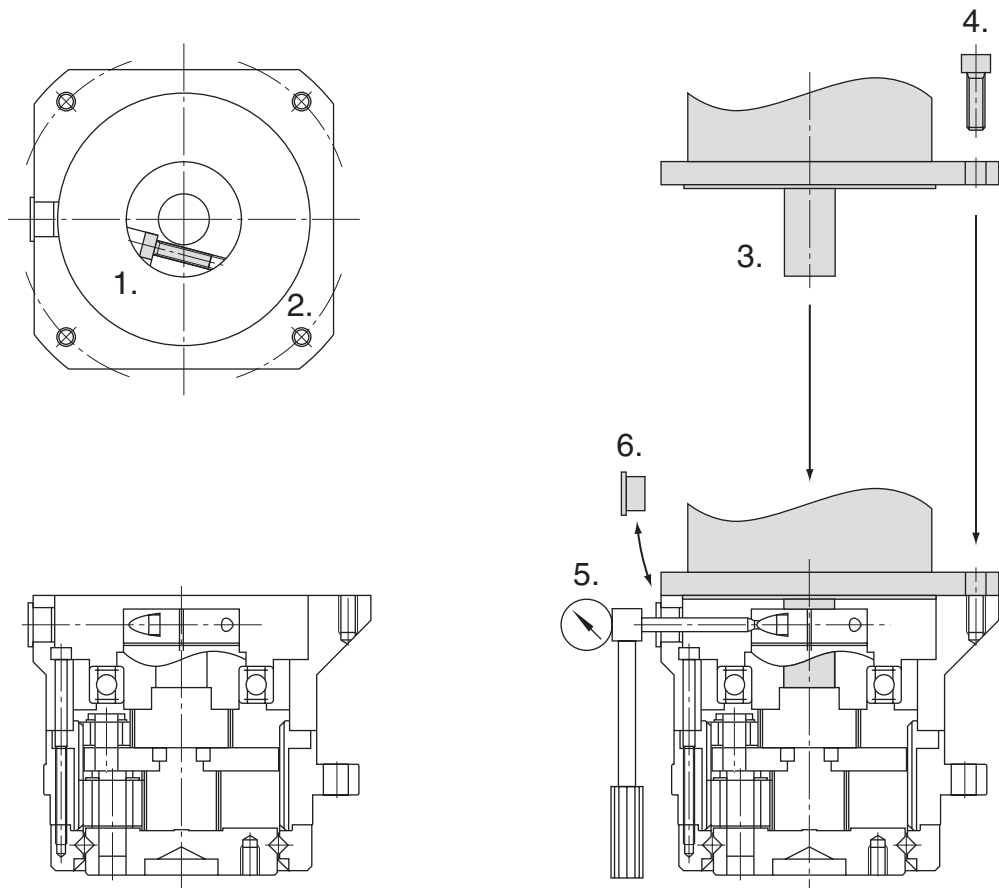

● Installing the Reduction Gear into the machine.

Confirm the mounting surface flatness and installation burr does not exist, and fix the mounting flange with bolts when installing R88G-HPG □□□.

Tightening torque of the bolt on the mounting flange (for aluminum)

R88G-HPG	11B	14A	20A	32A	50A	65A
Number of bolts	4	4	4	4	4	4
Size of bolts	M3	M5	M8	M10	M12	M16
Mounting PCD (mm)	46	70	105	135	190	260
Tightening torque (N·m)	1.4	6.3	26.1	51.5	103	255

Note If the key on a Servomotor with key is uninstalled, it is possible to use the reduction gear by installing the Servomotor without above mentioned key. Slipping does not occur.

● Installing the R88G-VRSF □□□ (15 Arcminutes type)

Follow the instructions below for installing this Reduction Gear and the Servomotor.

- 1** Fit the bolt head of the shaft fixing bolt to the rubber cap by turning the input coupling.
Confirm the set bolt is loose.

- 2** Gently insert the Servomotor into the reduction gear.

Put up the reduction gear vertically and let it slide into the input shaft coupling, so as not to fall, using the motor shaft as guide, as shown in the below diagrams. When the reduction gear cannot be put up vertically, take care not to install the motor tilted by such as tightening a bolt uniformly.

- 3** Fix the Servomotor and the flange of the reduction gear with bolts.

Bolt tightening torque

Size of the hexagon socket head cap screw	M4	M5
Tightening torque (N·m)	3.0	5.8

- 4** Tighten the bolts of the input coupling.

Bolt tightening torque (for duralumin)

Size of the hexagon socket head cap screw	M3	M4
Tightening torque (N·m)	1.5	3.5

Note Tighten the bolts using the torque indicated on the above table. The problem such as slipping may occur when using the other unspecified torque.

- 5** Mount the rubber cap to complete the installation.

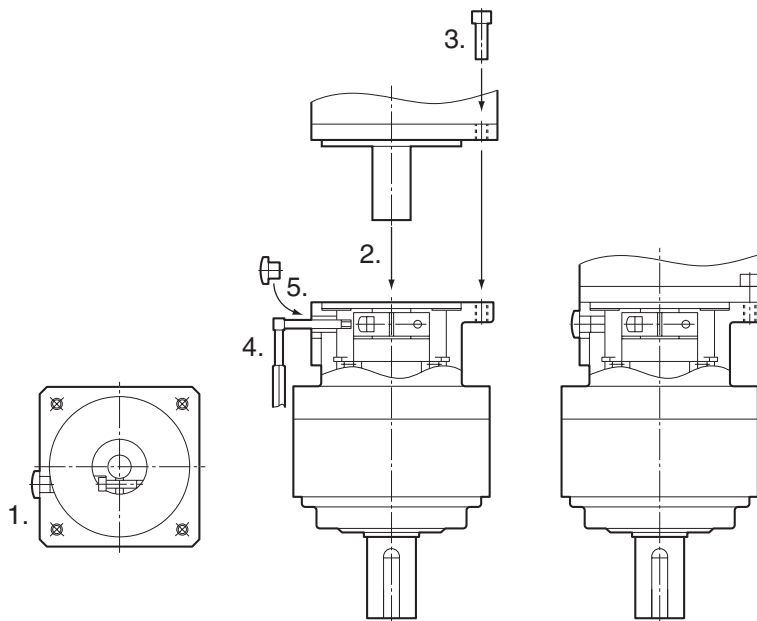

● Installing the Reduction Gear into the machine.

Confirm the mounting surface flatness and installation burr does not exist, and fix the mounting flange with bolts when installing R88G-VRSF □□□.

Tightening torque of the bolt on the mounting flange (for aluminum)

R88G-VRSF	Frame B	Frame C	Frame D
Number of bolts	4	4	4
Size of bolts	M5	M6	M8
Mounting PCD (mm)	60	90	115
Tightening torque (N·m)	5.8	9.8	19.6

Note If the key on a Servomotor with key is uninstalled, it is possible to use the reduction gear by installing the Servomotor without above mentioned key. Slipping does not occur.

Using Another Company's Decelerator (Reference)

If the system configuration requires another company's decelerator to be used in combination with a G5-series Servomotor, select the decelerator so that the loads on the motor shaft (i.e., both the radial and thrust loads) are within the allowable ranges. (Refer to *3-1-2 Characteristics* on page 3-3 for details on the allowable loads for the motors.)

Also, select the decelerator so that the allowable input rotation speed and allowable input torque of the decelerator are not exceeded.

4-2 Wiring

4-2-1 Power Cables for 1,500-r/min Servomotors

For a 1,500-r/min Servomotor with 11 kW or 15 kW, make the following cable yourself and use it to connect the Servomotor and Servo Drive.

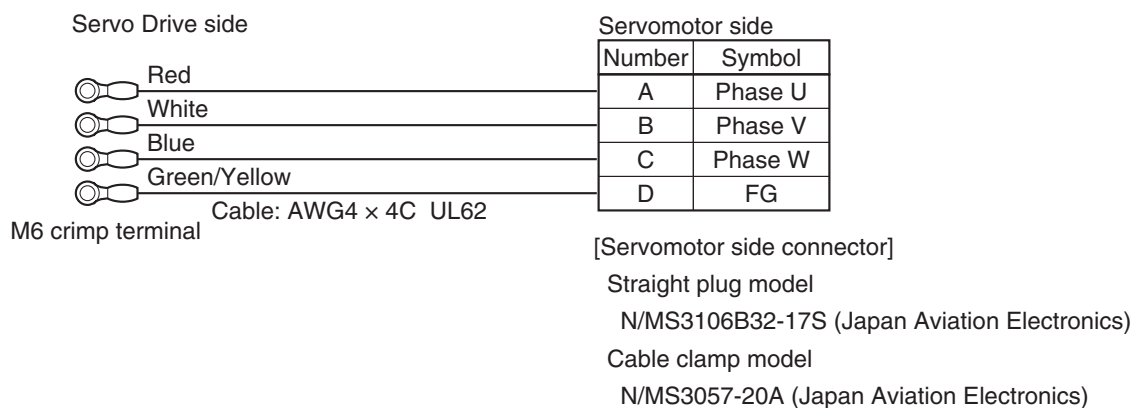

Note 1 The cable length between the Servomotor and Servo Drive must be 50 m or less.
Use wire lengths that match the positions of the U, V, W, and FG terminals on the Servo Driver (M6 crimp terminals).

2 The power connector and brake connector are separate for Servomotors with brakes.

- Servomotor Side Pin Arrangement (View from Soldered Side of Plug)

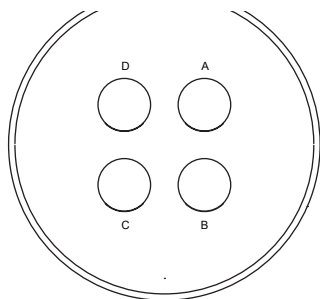

4-2-2 Peripheral Equipment Connection Examples

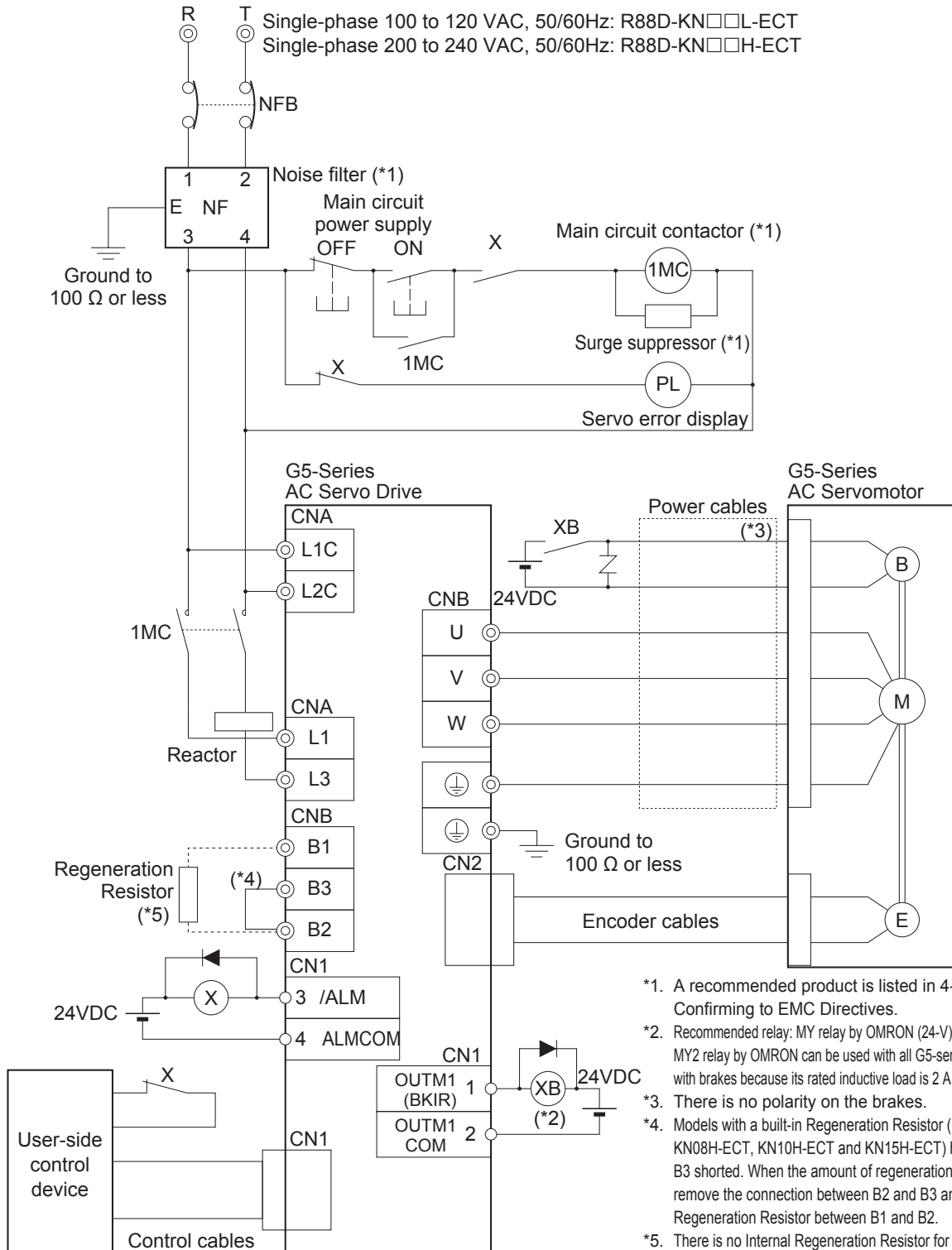
**R88D-KNA5L-ECT/-KN01L-ECT/-KN02L-ECT/-KN04L-ECT
 R88D-KN01H-ECT/-KN02H-ECT/-KN04H-ECT/-KN08H-ECT/
 R88D-KN10H-ECT/-KN15H-ECT (Single-phase Input)**

- *1. A recommended product is listed in 4-3, Wiring Confirming to EMC Directives.
- *2. Recommended relay: MY relay by OMRON (24-V) For example, MY2 relay by OMRON can be used with all G5-series motors with brakes because its rated inductive load is 2 A (24 VDC).
- *3. There is no polarity on the brakes.
- *4. Models with a built-in Regeneration Resistor (KN04L-ECT, KN08H-ECT, KN10H-ECT and KN15H-ECT) have B2 and B3 shorted. When the amount of regeneration is large, remove the connection between B2 and B3 and connect a Regeneration Resistor between B1 and B2.
- *5. There is no Internal Regeneration Resistor for KNA5L-ECT to KN02L-ECT, and KN01H-ECT to KN04H-ECT. When the amount of regeneration is large, connect the necessary Regeneration Resistor between B1 and B2.

R88D-KN01H-ECT/-KN02H-ECT/-KN04H-ECT/-KN08H-ECT/ -KN10H-ECT/-KN15H-ECT (3-phase Input)

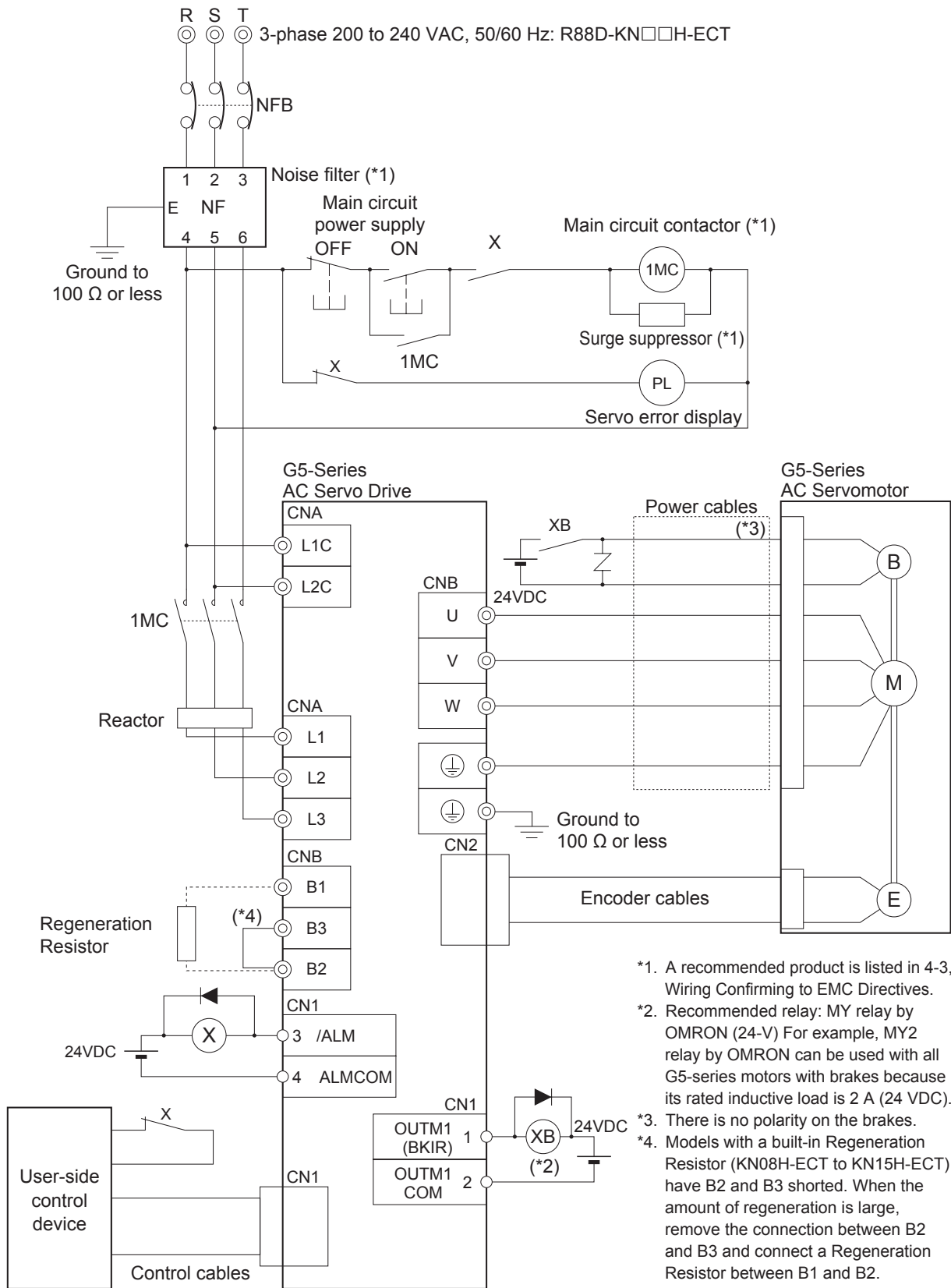

R88D-KN20H-ECT

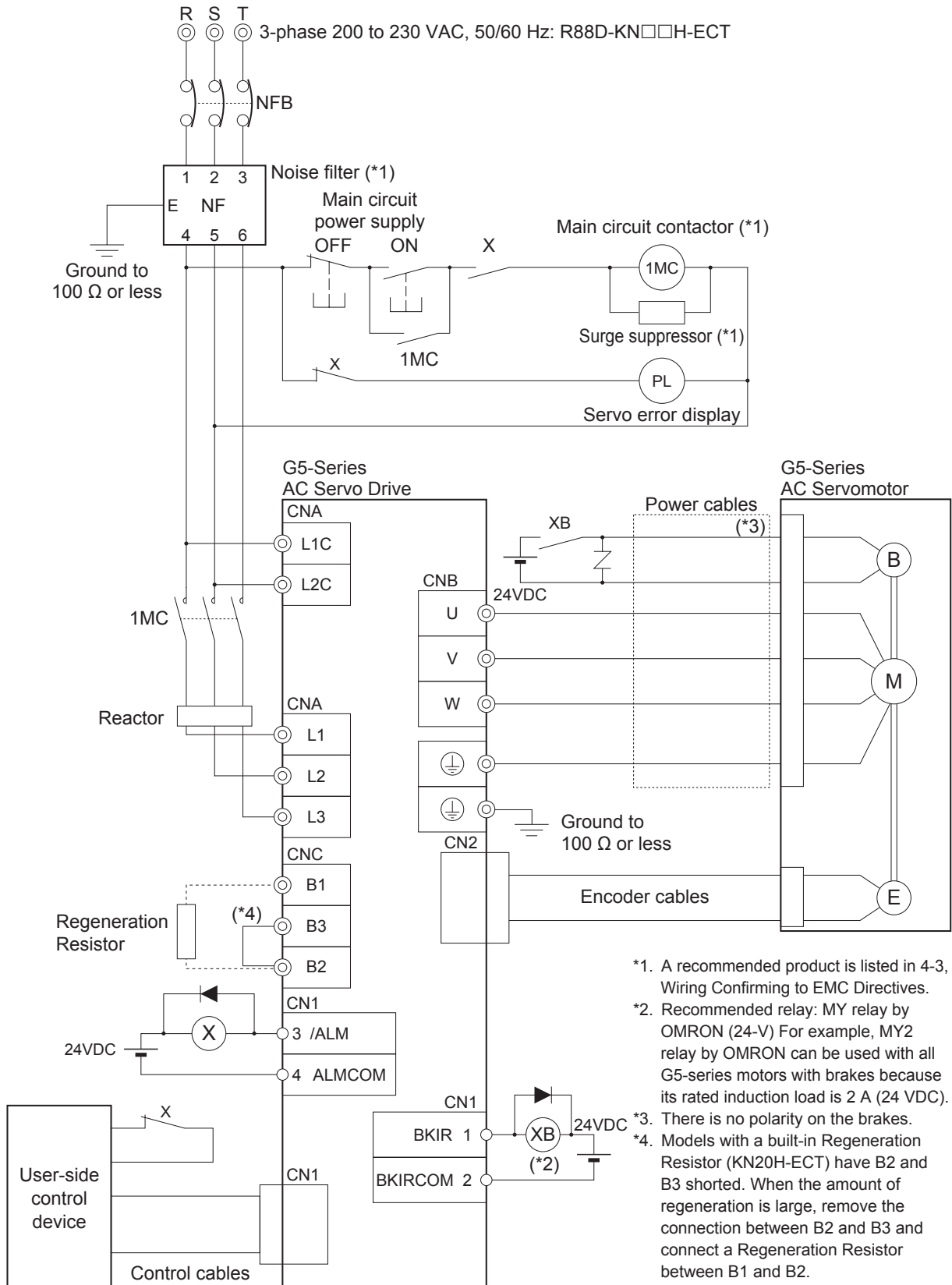

- *1. A recommended product is listed in 4-3, Wiring Confirming to EMC Directives.
- *2. Recommended relay: MY relay by OMRON (24-V) For example, MY2 relay by OMRON can be used with all G5-series motors with brakes because its rated induction load is 2 A (24 VDC).
- *3. There is no polarity on the brakes.
- *4. Models with a built-in Regeneration Resistor (KN20H-ECT) have B2 and B3 shorted. When the amount of regeneration is large, remove the connection between B2 and B3 and connect a Regeneration Resistor between B1 and B2.

4-2 Wiring
4
4-2-2 Peripheral Equipment Connection Examples

R88D-KN30H-ECT/-KN50H-ECT

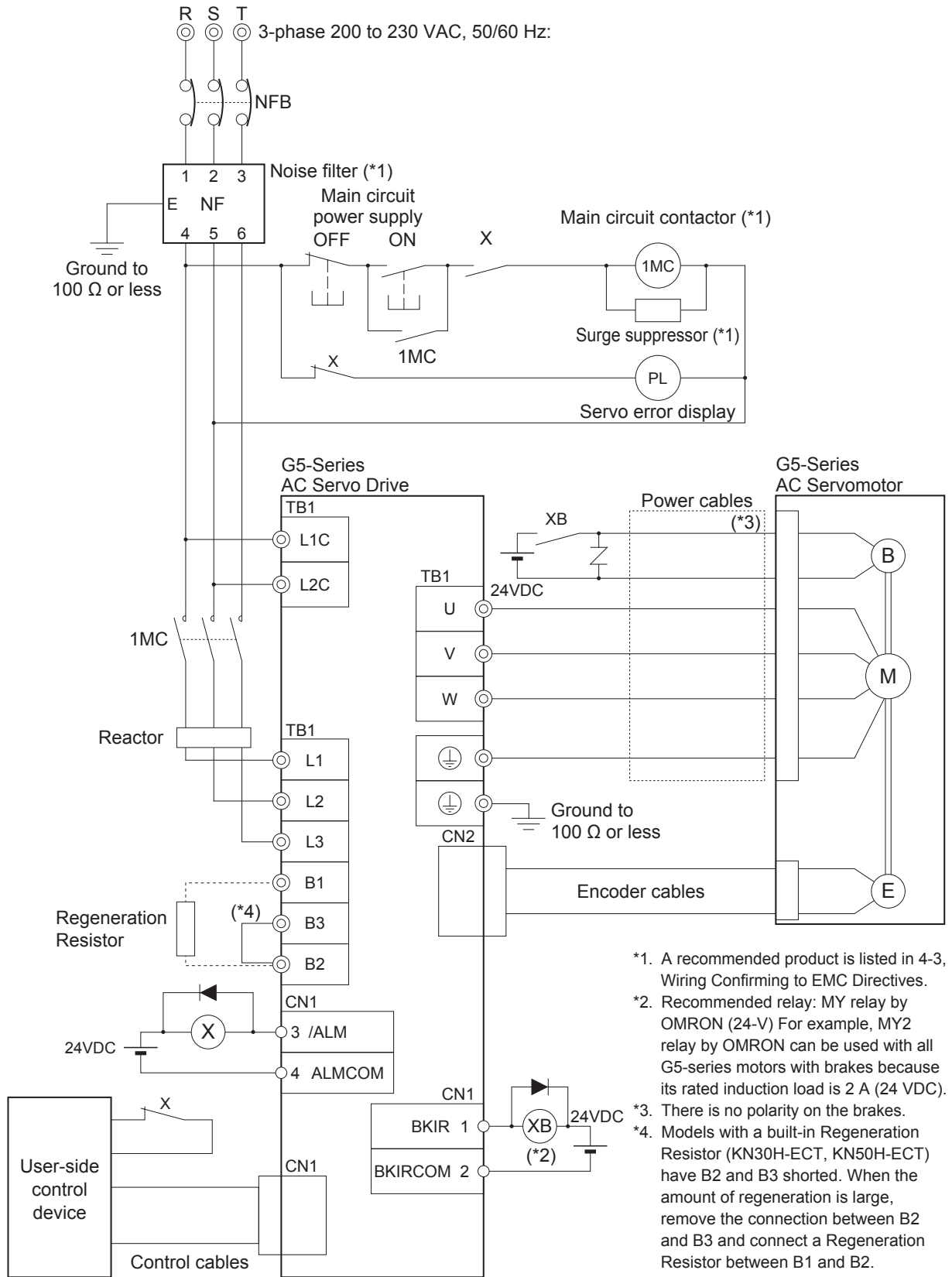

R88D-KN75H-ECT (AC power input)

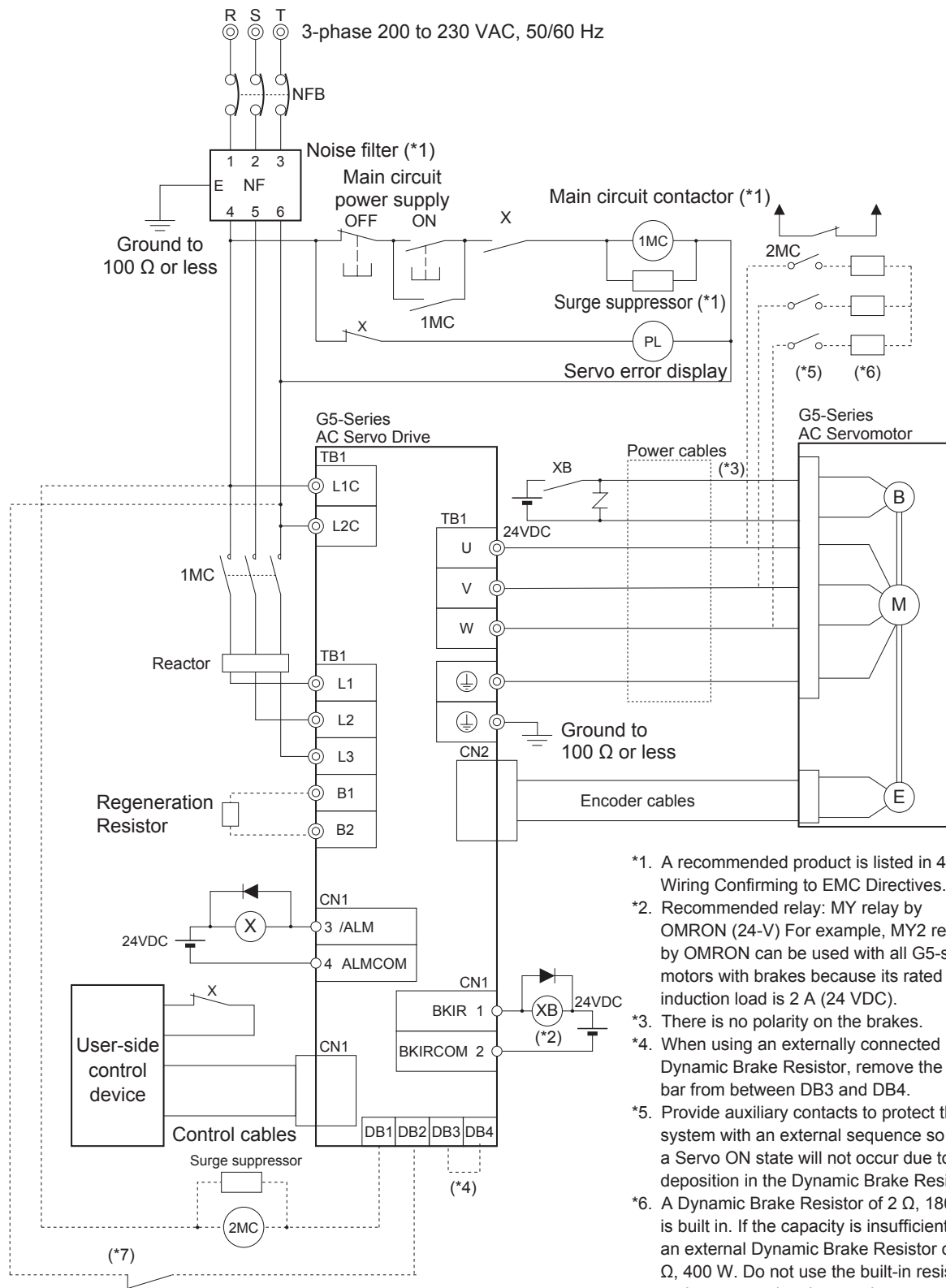

- *1. A recommended product is listed in 4-3, Wiring Confirming to EMC Directives.
- *2. Recommended relay: MY relay by OMRON (24-V) For example, MY2 relay by OMRON can be used with all G5-series motors with brakes because its rated induction load is 2 A (24 VDC).
- *3. There is no polarity on the brakes.
- *4. When using an externally connected Dynamic Brake Resistor, remove the short bar from between DB3 and DB4.
- *5. Provide auxiliary contacts to protect the system with an external sequence so that a Servo ON state will not occur due to deposition in the Dynamic Brake Resistor.
- *6. A Dynamic Brake Resistor of 2 Ω , 180 W is built in. If the capacity is insufficient, use an external Dynamic Brake Resistor of 1.2 Ω , 400 W. Do not use the built-in resistor and an external resistor at the same time.
- *7. Install an external protective device, such as a temperature fuse. Monitor the temperature of the external Dynamic Brake Resistor.

R88D-KN150H-ECT (AC power input)

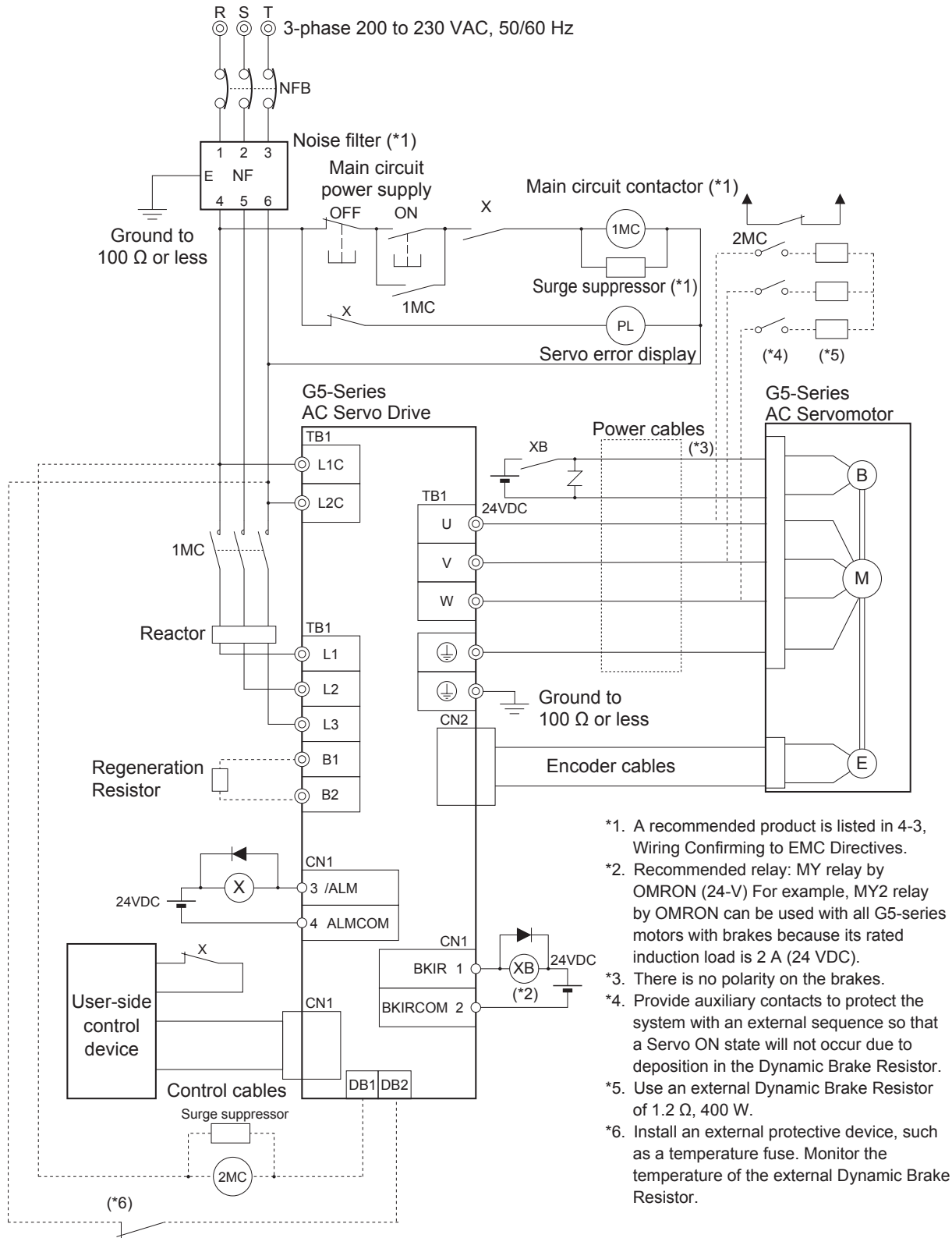

R88D-KN06F-ECT/-KN10F-ECT/-KN15F-ECT/-KN20F-ECT

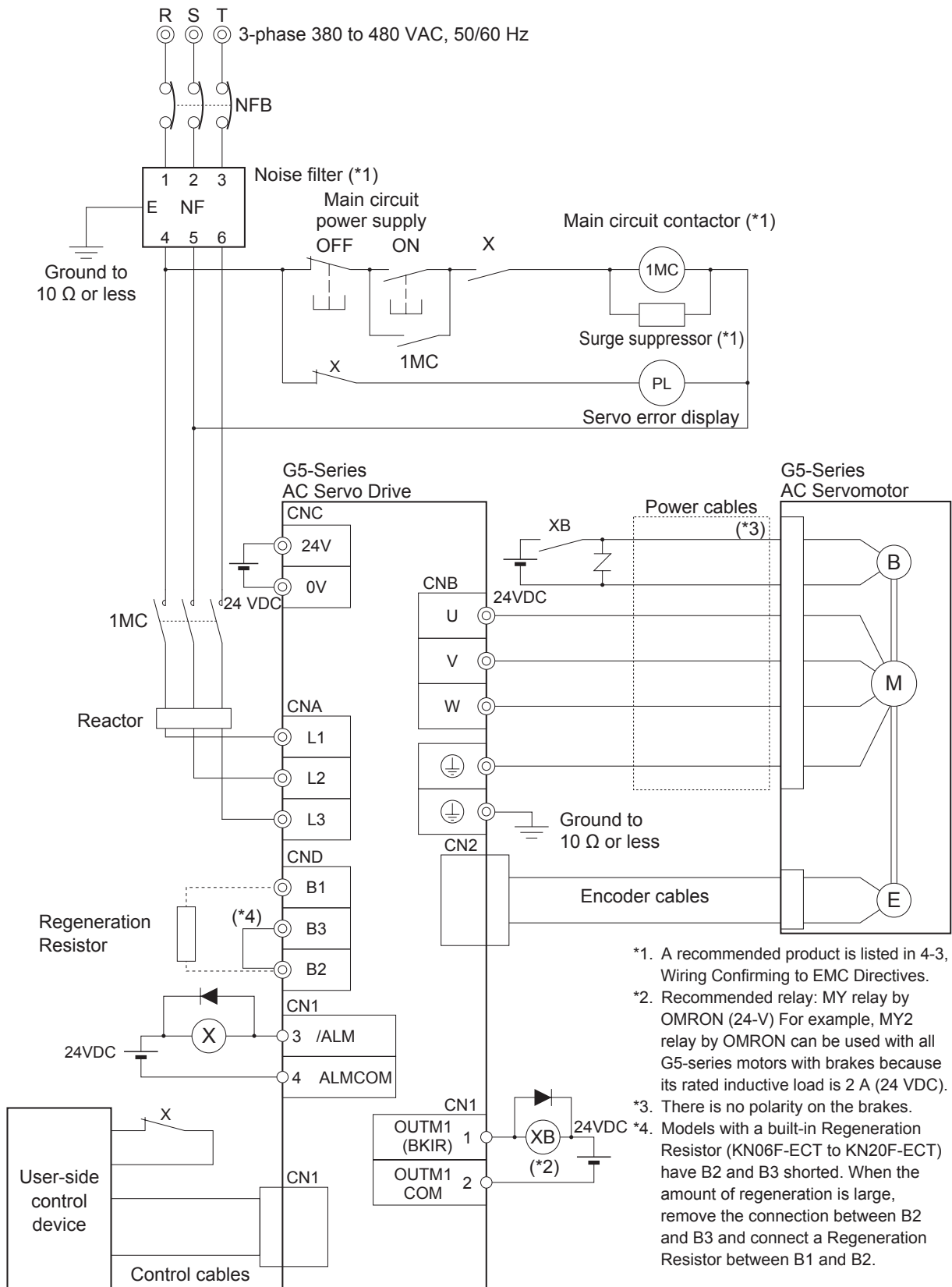

- *1. A recommended product is listed in 4-3, Wiring Confirming to EMC Directives.
- *2. Recommended relay: MY relay by OMRON (24-V) For example, MY2 relay by OMRON can be used with all G5-series motors with brakes because its rated inductive load is 2 A (24 VDC).
- *3. There is no polarity on the brakes.
- *4. Models with a built-in Regeneration Resistor (KN06F-ECT to KN20F-ECT) have B2 and B3 shorted. When the amount of regeneration is large, remove the connection between B2 and B3 and connect a Regeneration Resistor between B1 and B2.

R88D-KN30F-ECT/-KN50F-ECT

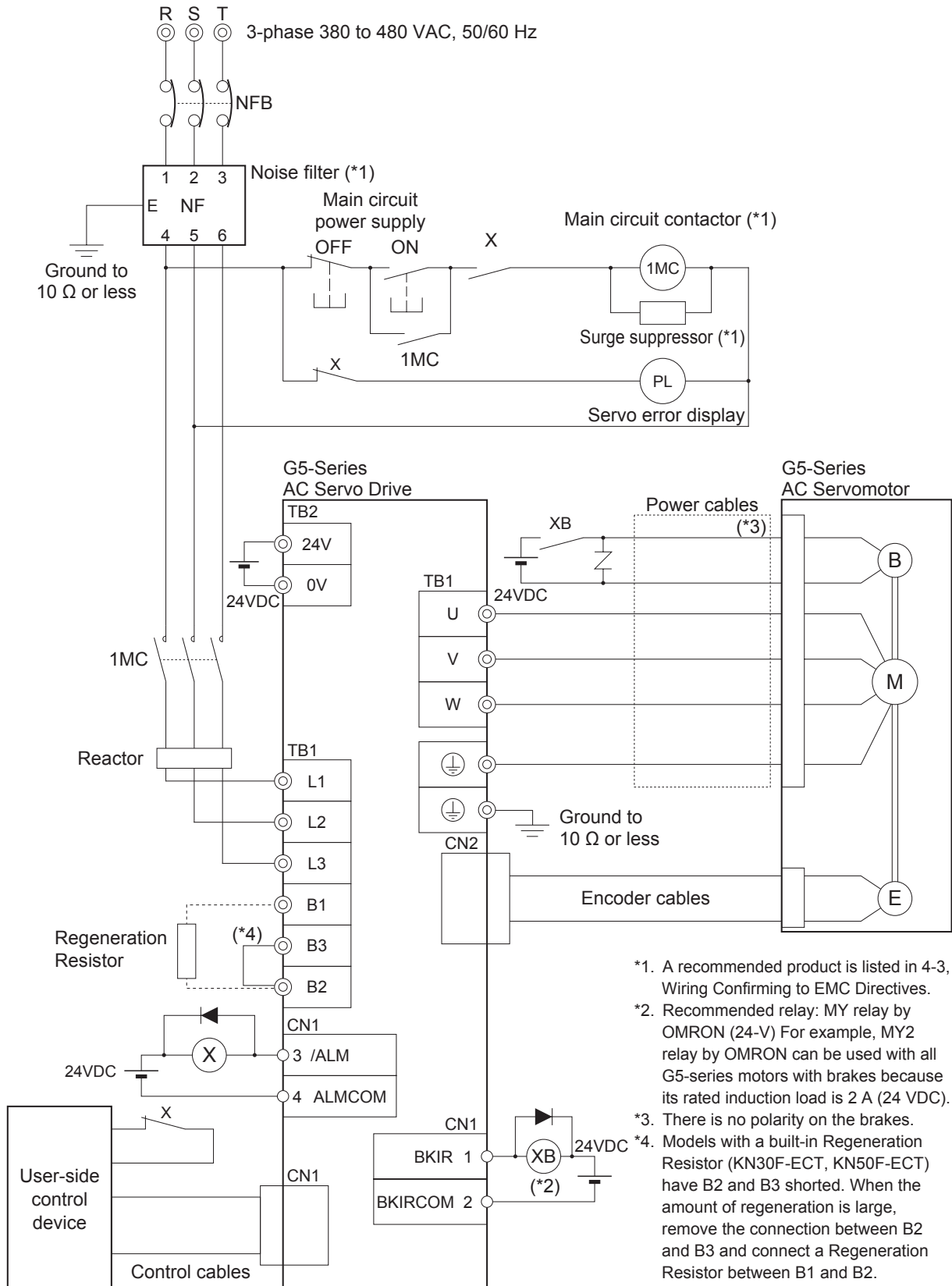

R88D-KN75F-ECT

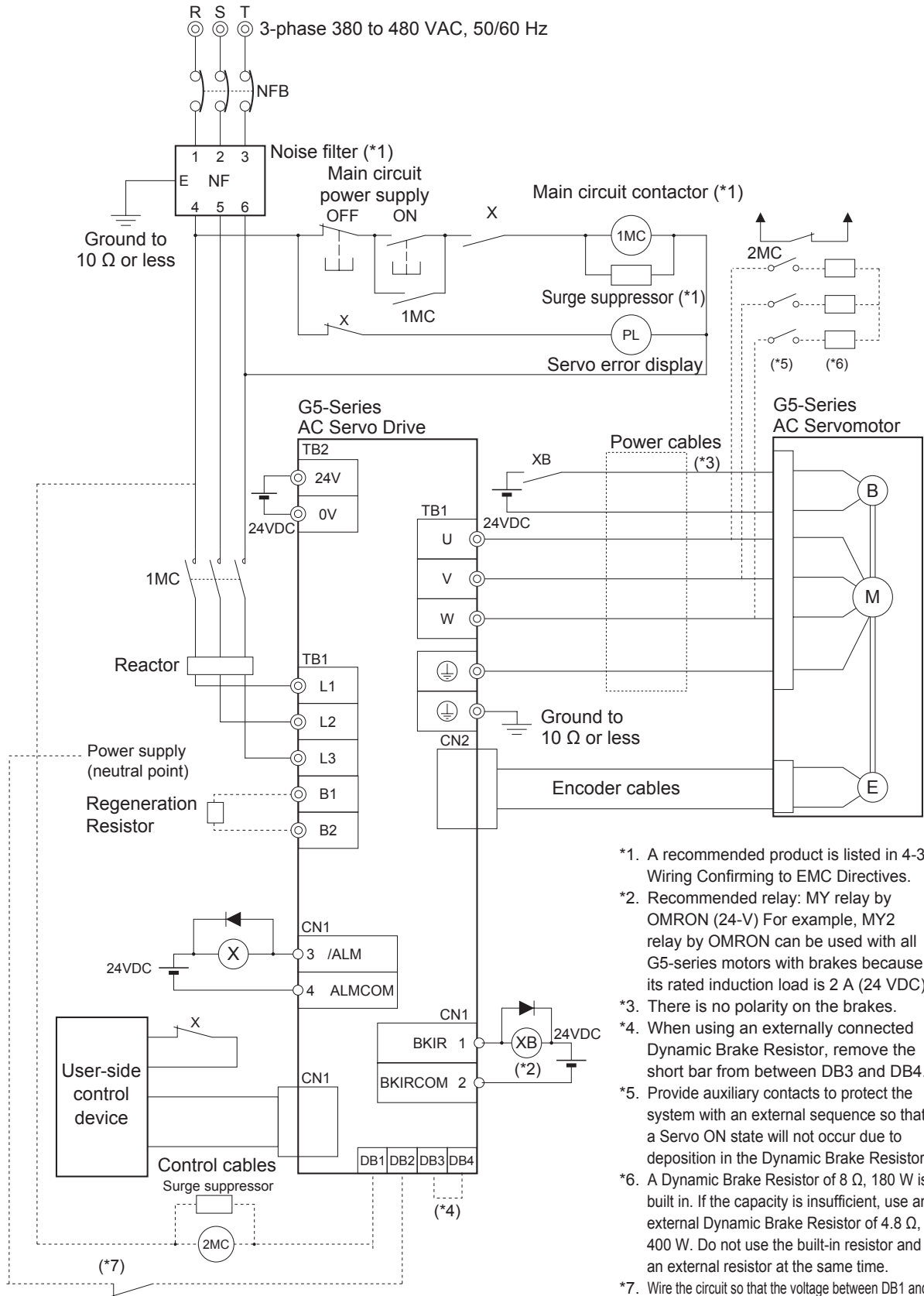

- *1. A recommended product is listed in 4-3, Wiring Confirming to EMC Directives.
- *2. Recommended relay: MY relay by OMRON (24-V) For example, MY2 relay by OMRON can be used with all G5-series motors with brakes because its rated induction load is 2 A (24 VDC).
- *3. There is no polarity on the brakes.
- *4. When using an externally connected Dynamic Brake Resistor, remove the short bar from between DB3 and DB4.
- *5. Provide auxiliary contacts to protect the system with an external sequence so that a Servo ON state will not occur due to deposition in the Dynamic Brake Resistor.
- *6. A Dynamic Brake Resistor of 8 Ω, 180 W is built in. If the capacity is insufficient, use an external Dynamic Brake Resistor of 4.8 Ω, 400 W. Do not use the built-in resistor and an external resistor at the same time.
- *7. Wire the circuit so that the voltage between DB1 and DB2 is 400 VAC or less. Install an external protective device, such as a temperature fuse. Monitor the temperature of the external Dynamic Brake Resistor.

R88D-KN150F-ECT

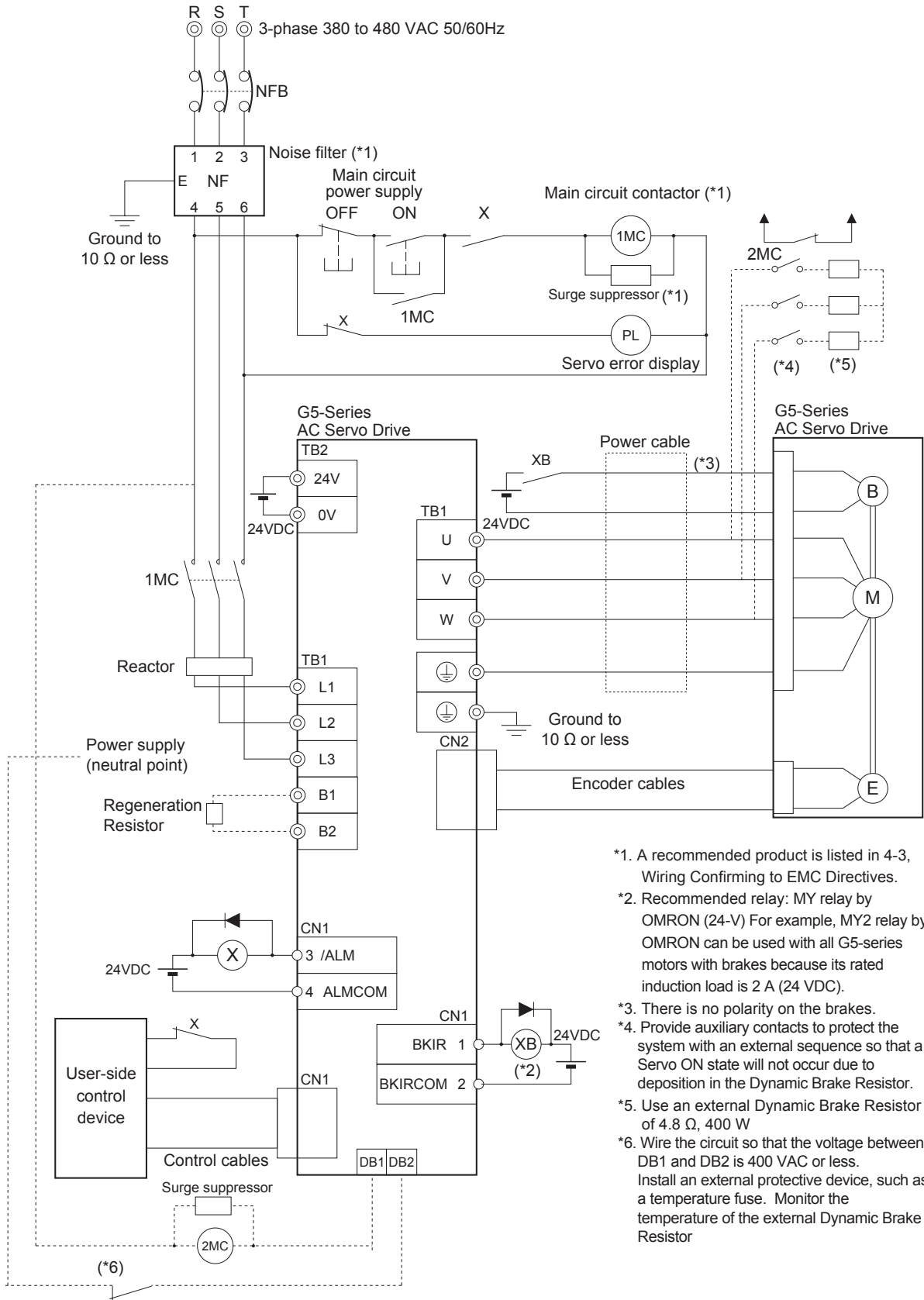

- *1. A recommended product is listed in 4-3, Wiring Confirming to EMC Directives.
- *2. Recommended relay: MY relay by OMRON (24-V) For example, MY2 relay by OMRON can be used with all G5-series motors with brakes because its rated induction load is 2 A (24 VDC).
- *3. There is no polarity on the brakes.
- *4. Provide auxiliary contacts to protect the system with an external sequence so that a Servo ON state will not occur due to deposition in the Dynamic Brake Resistor.
- *5. Use an external Dynamic Brake Resistor of 4.8 Ω, 400 W
- *6. Wire the circuit so that the voltage between DB1 and DB2 is 400 VAC or less. Install an external protective device, such as a temperature fuse. Monitor the temperature of the external Dynamic Brake Resistor

4-2-3 Main Circuit and Motor Connections

When wiring the main circuit, use proper wire sizes, grounding systems, and noise resistance.

R88D-KNA5L-ECT/-KN01L-ECT/-KN02L-ECT/-KN04L-ECT/ R88D-KN01H-ECT/-KN02H-ECT/-KN04H-ECT/-KN08H-ECT/ R88-KN10H-ECT/-KN15H-ECT

● Main Circuit Connector Specifications (CNA)

Symbol	Name	Function
L1	Main circuit power supply input	R88D-KN□L-ECT 50 to 400 W : Single-phase 100 to 120 VAC (85 to 132 VAC) 50/60 Hz
L2		R88D-KN□H-ECT 100 W to 1.5 kW : Single-phase 200 to 240 VAC (170 to 264 VAC) 50/60 Hz
L3		100 W to 1.5 kW : 3-phase 200 to 240 VAC (170 to 264 VAC) 50/60 Hz
L1C	Control circuit power supply input	R88D-KN□L-ECT : Single-phase 100 to 120 VAC (85 to 132 VAC) 50/60Hz
L2C		R88D-KN□H-ECT : Single-phase 200 to 240 VAC (170 to 264 VAC) 50/60 Hz

● Motor Connector Specifications (CNB)

Symbol	Name	Function
B1	External Regeneration Resistor connection terminals	50 to 400 W: Normally, do not short B1 and B2. Doing so may result in malfunctioning. If there is high regenerative energy, connect an External Regeneration Resistor between B1 and B2. 750 W to 1.5 kW: Normally B2 and B3 are shorted. Do not short B1 and B2. Doing so may result in malfunctioning. If there is high regenerative energy, remove the short bar between B2 and B3 and connect an External Regeneration Resistor between B1 and B2.
B3		
B2		
U	Motor connection terminals	Red
V		White
W		Blue
⊕		Green/ Yellow
⊕	Frame ground	This is the ground terminal. Ground to 100 Ω or less.

R88D-KN20H-ECT

● Main Circuit Connector Specifications (CNA)

Symbol	Name	Function
L1	Main circuit power supply input	R88D-KN□H-ECT (2 kW) : 3-phase: 200 to 230 VAC (170 to 253 VAC) 50/60 Hz
L2		
L3		
L1C	Control circuit power supply input	R88D-KN□H-ECT : Single-phase 200 to 230 VAC (170 to 253 VAC) 50/60 Hz
L2C		

● Motor Connector Specifications (CNB)

Symbol	Name	Function	
U	Motor connection terminals	Red	These are the output terminals to the Servomotor. Be sure to wire them correctly.
V		White	
W		Blue	
⊕		Green/ Yellow	
⊕	Frame ground	This is the ground terminal. Ground to 100 Ω or less.	

● External Regeneration Resistor Connector Specifications (CNC)

Symbol	Name	Function
B1	External Regeneration Resistor connection terminals	Normally B2 and B3 are shorted. Do not short B1 and B2. Doing so may result in malfunctioning. If there is high regenerative energy, remove the short-circuit bar between B2 and B3 and connect an External Regeneration Resistor between B1 and B2.
B3		
B2		
NC	Do not connect.	



Precautions for Correct Use

- Do not connect any External Regeneration Resistors between B1 and NC.

R88D-KN30H-ECT/-KN50H-ECT

● Terminal Block Specifications

Symbol	Name	Function	
L1	Main circuit power supply input	R88D-KN□H-ECT (3 to 5 kW): 3-phase 200 to 230 VAC (170 to 253 VAC) 50/60 Hz	
L2			
L3			
L1C	Control circuit power supply input	R88D-KN□H-ECT: Single-phase 200 to 230 VAC (170 to 253 VAC) 50/60 Hz	
L2C			
B1	External Regeneration Resistor connection terminals	Normally B2 and B3 are shorted. Do not short B1 and B2. Doing so may result in malfunctioning. If there is high regenerative energy, remove the short-circuit bar between B2 and B3 and connect an External Regeneration Resistor between B1 and B2.	
B3			
B2			
NC	Do not connect.		
U	Motor connection terminals	Red	These are the output terminals to the Servomotor. Be sure to wire them correctly.
V		White	
W		Blue	
⊕		Green/ Yellow	
⊕	Frame ground	This is the ground terminal. Ground to 100 Ω or less.	



Precautions for Correct Use

- Do not connect any External Regeneration Resistors between B1 and NC.

R88D-KN75H-ECT

● Terminal Block Specifications, Left Terminal Block (TB1)

Symbol	Name	Function	
L1	Main circuit power supply input	R88D-KN□H-ECT (7.5 kW): 3-phase 200 to 230 VAC (170 to 253 VAC) 50/60 Hz 280 to 325 VDC (238 to 357 VAC)	
L2			
L3			
B1	External Regeneration Resistor connection terminals	Connect an External Regeneration Resistor between B1 and B2.	
B2			
N*1			
U	Motor connection terminals	Red	These are the output terminals to the Servomotor. Be sure to wire them correctly.
V		White	
W		Blue	
⊕		Green/ Yellow	

*1 The symbol "N" is found on G5-series AC Servo Drives with unit version 2.1 or later.



Precautions for Correct Use

- Do not connect any External Regeneration Resistors between B1 and N (or NC).

● Terminal Block Specifications, Right Terminal Block (TB2)

Symbol	Name	Function
L1C	Control circuit power supply input	R88D-KN□H-ECT: Single-phase 200 to 230 VAC (170 to 253 VAC) 50/60 Hz 280 to 325 VDC (238 to 357 VAC)
L2C		
DB1	Dynamic Brake Resistor control terminals	These terminals are used to control the MC for externally connected dynamic brake resistance. The output contact specifications are 1 A max. at 300 VAC/100 VDC max. Connect them if required.
DB2		
DB3		Normally DB3 and DB4 are shorted.
DB4		When using an externally connected Dynamic Brake Resistor, remove the short bar from between DB3 and DB4.
⊕	Frame ground	This is the ground terminal. Ground it to 100 Ω or less.

R88D-KN150H-ECT

● Terminal Block Specifications, Top Terminal Block (TB1)

Symbol	Name	Function
L1C	Control circuit power supply input	R88D-KN□H-ECT: Single-phase 200 to 230 VAC (170 to 253 VAC) 50/60 Hz 280 to 325 VDC (238 to 357 VAC)
L2C		
DB1	Dynamic Brake Resistor control terminals	These terminals are used to control the MC for externally connected dynamic brake resistance. The output contact specifications are 1 A max. at 300 VAC/100 VDC max. Connect them if required.
DB2		

● Terminal Block Specifications, Bottom Terminal Block (TB2)

Symbol	Name	Function
L1	Main circuit power supply input	R88D-KN□H-ECT (7.5 kW): 3-phase 200 to 230 VAC (170 to 253 VAC) 50/60 Hz 280 to 325 VDC (238 to 357 VAC)
L2		
L3		
B1	External Regeneration Resistor connection terminals	Connect an External Regeneration Resistor between B1 and B2.
B2		
N*1		
U	Motor connection terminals	These are the output terminals to the Servomotor. Be sure to wire them correctly.
V		
W		
⊕		
⊕	Frame ground	This is the ground terminal. Ground to 100 Ω or less.

*1 The symbol "N" is found on G5-series AC Servo Drives with unit version 2.1 or later.



Precautions for Correct Use

- Do not connect any External Regeneration Resistors between B1 and N (or NC)

R88D-KN06F-ECT/-KN10F-ECT/-KN15F-ECT/-KN20F-ECT

● Main Circuit Connector Specifications (CNA)

Symbol	Name	Function
L1	Main circuit power supply input	R88D-KN□F-ECT (600 W to 2 kW) : 3-phase: 380 to 480 VAC (323 to 528 VAC) 50/60 Hz
L2		
L3		

● Motor Connector Specifications (CNB)

Symbol	Name	Function	
U	Motor connection terminals	Red	These are the output terminals to the Servomotor. Be sure to wire them correctly.
V		White	
W		Blue	
⊕		Green/ Yellow	
⊕	Frame ground	This is the ground terminal. Ground to 10 Ω or less.	

● Control Circuit Connector Specifications (CNC)

Symbol	Name	Function
24 V	Control circuit power supply input	24 VDC (21.6 to 26.4 VDC)
0 V		

● External Regeneration Resistor Connector Specifications (CND)

Symbol	Name	Function
B1	External Regeneration Resistor connection terminals	Normally B2 and B3 are shorted. Do not short B1 and B2. Doing so may result in malfunctioning. If there is high regenerative energy, remove the short-circuit bar between B2 and B3 and connect an External Regeneration Resistor between B1 and B2.
B3		
B2		
NC	Do not connect.	



Precautions for Correct Use

- Do not connect any External Regeneration Resistors between B1 and NC.

R88D-KN30F-ECT/-KN50F-ECT

● Terminal Block Specifications (TB1)

Symbol	Name	Function
24 V	Control circuit power supply input	24 VDC (21.6 to 26.4 VDC)
0 V		

● Terminal Block Specifications (TB2)

Symbol	Name	Function	
L1	Main circuit power supply input	R88D-KN□F-ECT (3 to 5 kW): 3-phase 380 to 480 VAC (323 to 528 VAC) 50/60 Hz	
L2			
L3			
B1	External Regeneration Resistor connection terminals	A Regeneration Resistor is not built in.	
B3		Connect an External Regeneration Resistor between B1 and B2, if necessary. Normally, do not short B1 and B2. Doing so may result in malfunctioning.	
B2			
NC	Do not connect.		
U	Motor connection terminals	Red	These are the output terminals to the Servomotor. Be sure to wire them correctly.
V		White	
W		Blue	
⊕		Green/ Yellow	
⊕		Frame ground	



Precautions for Correct Use

- Do not connect any External Regeneration Resistors between B1 and NC.

R88D-KN75F-ECT

● Terminal Block Specifications, Left Terminal Block (TB1)

Symbol	Name	Function	
L1	Main circuit power supply input	R88D-KN□F-ECT (7.5 kW): 3-phase 380 to 480 VAC (323 to 528 VAC) 50/60 Hz	
L2			
L3			
B1	External Regeneration Resistor connection terminals	Connect an External Regeneration Resistor between B1 and B2.	
B2			
NC	Do not connect.		
U	Motor connection terminals	Red	These are the output terminals to the Servomotor. Be sure to wire them correctly.
V		White	
W		Blue	
⊕		Green/ Yellow	



Precautions for Correct Use

- Do not connect any External Regeneration Resistors between B1 and NC.

● Terminal Block Specifications, Right Terminal Block (TB2)

Symbol	Name	Function
24 V	Control circuit power supply input	24 VDC \pm 15%
0 V		
DB1	Dynamic Brake Resistor control terminals	These terminals are used to control the MC for externally connected dynamic brake resistance. The output contact specifications are 1 A max. at 300 VAC/100 VDC max. Connect them if required.
DB2		
DB3	DB3 and DB4 are shorted.	Normally DB3 and DB4 are shorted. When using an externally connected Dynamic Brake Resistor, remove the short bar from between DB3 and DB4.
DB4		
⊕	Frame ground	This is the ground terminal. Ground to 10 Ω or less.

R88D-KN150F-ECT

● Terminal Block Specifications, Top Terminal Block (TB1)

Symbol	Name	Function
24 V	Control circuit power supply input	24 VDC \pm 15%
0 V		
DB1	Dynamic Brake Resistor control terminals	These terminals are used to control the MC for externally connected dynamic brake resistance. The output contact specifications are 1 A max. at 300 VAC/100 VDC max. Connect them if required.
DB2		

● Terminal Block Specifications, Bottom Terminal Block (TB2)

Symbol	Name	Function
L1	Main circuit power supply input	R88D-KN□F-ECT (15 kW); 3-phase 380 to 480 VAC (323 to 528 VAC) 50/60 Hz
L2		
L3		
B1	External Regeneration Resistor connection terminals	Connect an External Regeneration Resistor between B1 and B2.
B2		
NC	Do not connect.	
U	Motor connection terminals	Red
V		White
W		Blue
⊕		Green/ Yellow
⊕	Frame ground	This is the ground terminal. Ground to 10 Ω or less.



Precautions for Correct Use

- Do not connect any External Regeneration Resistors between B1 and NC.

Terminal Block Wire Sizes

● 100-VAC Input Drive Wire Sizes: R88D-KN□□L-ECT

Model (R88D-)		Unit	KNA5L-ECT	KN01L-ECT	KN02L-ECT	KN04L-ECT
Item						
Power supply capacity		kVA	0.4	0.4	0.5	0.9
Main circuit power supply input (L1 and L3, or L1, L2 and L3)	Rated current	A	1.7	2.6	4.3	7.6
	Wire size	–	AWG 14 to 18			
Control circuit power supply input (L1C and L2C)	Wire size	–	AWG 18			
Motor connection terminals (U, V, W, and FG) *1*2	Rated current	A	1.2	1.7	2.5	4.6
	Wire size	–	AWG 14 to 18			
Frame ground (FG)	Wire size	–	AWG 14			
	Screw size	–	M4			
	Tightening torque	N·m	1.2			

*1 Connect OMRON Power Cables to the motor connection terminals.

*2 Use the same wire size for B1 and B2.

● 200 VAC Input Drive Wire Sizes: R88D-KN□H-ECT

Model (R88D-)		Unit	KN01H-ECT	KN02H-ECT	KN04H-ECT	KN08H-ECT	KN10H-ECT
Item							
Power supply capacity		kVA	0.5	0.5	0.9	1.3	1.8
Main circuit power supply input (L1 and L3, or L1, L2 and L3)	Rated current	A	1.6/0.9*1	2.4/1.3*1	4.1/2.4*1	6.6/3.6*1	9.1/5.2*1
	Wire size	–	AWG14 to 18				AWG14
	Screw size	–	–	–	–	–	–
	Tightening torque	N·m	–	–	–	–	–
Control circuit power supply input (L1C and L2C)	Wire size	–	AWG18				
	Screw size	–	–	–	–	–	–
	Tightening torque	N·m	–	–	–	–	–
Motor connection terminals (U, V, W, and FG) *2 *3	Rated current	A	1.2	1.6	2.6	4.1	5.9
	Wire size	–	AWG14 to 18				AWG14
	Screw size	–	–	–	–	–	–
	Tightening torque	N·m	–	–	–	–	–
Frame ground (FG)	Wire size	–	AWG14				
	Screw size	–	M4				
	Tightening torque	N·m	1.2				

Model (R88D-)		KN15H-ECT	KN20H-ECT	KN30H-ECT	KN50H-ECT	KN75H-ECT	KN150H-ECT	
Item	Unit							
Power supply capacity	kVA	2.3	3.3	4.5	7.5	11.0	22.0	
Main circuit power supply input (L1 and L3, or L1, L2 and L3)	Rated current	A	14.2/8.1 ^{*1}	11.8	15.1	21.6	32.0	58.0
	Wire size	–	AWG14		AWG12		AWG10	AWG6
	Screw size	–	–	–	M5		M6	
	Tightening torque	N·m	–	–	2.0		2.0 to 2.4	2.2 to 2.5
Control circuit power supply input (L1C and L2C)	Wire size	–	AWG18					
	Screw size	–	–	–	M5		M4	
	Tightening torque	N·m	–	–	2.0		1.3 to 1.5	0.7 to 0.8
Motor connection terminals (U, V, W, and FG) ^{*2 *3}	Rated current	A	9.4	13.4	18.7	33.0	44.0	66.1
	Wire size	–	AWG14		AWG12		AWG6	AWG4
	Screw size	–	–	–	M5		M6	
	Tightening torque	N·m	–	–	2.0		2.0 to 2.4	2.2 to 2.5
Frame ground (FG)	Wire size	–	AWG14		AWG12		AWG6	AWG4
	Screw size	–	M4		M5		M6	
	Tightening torque	N·m	1.2		2.0		1.4 to 1.6	2.4 to 2.8
Dynamic brake resistor control terminals	Wire size	–	–			AWG18		
	Screw size	–				M5	M6	
	Tightening torque	N·m				1.3 to 1.5	0.7 to 0.8	

*1 The first value is for single-phase input power and the second value is for 3-phase input power.

*2 Connect an OMRON power cable to the motor connection terminals.

*3 Use the same wire size for B1 and B2.

● 400 VAC Input Drive Wire Sizes: R88D-KN□□F-ECT

Model (R88D-)			KN06	KN10	KN15	KN20	KN30	KN50	KN75	KN150	
Item	Unit	F-ECT	F-ECT	F-ECT	F-ECT	F-ECT	F-ECT	F-ECT	F-ECT	F-ECT	
Main circuit power supply input (L1 and L3, or L1, L2 and L3)	Rated current	A	2.1	2.8	3.9	5.9	7.6	12.1	16.0	29.0	
	Wire size	–	AWG14				AWG12		AWG10	AWG6	
	Screw size	–	–	–	–	–	M5			M6	
	Tightening torque	N·m	–	–	–	–	2.0		2.0 to 2.4	2.2 to 2.5	
Control circuit power supply input (L1C and L2C)	Wire size	–	AWG20 to 24				AWG18				
	Screw size	–	–	–	–	–	M5			M4	
	Tightening torque	N·m	–	–	–	–	2.0		1.3 to 1.5	0.7 to 0.8	
Motor connection terminals (U, V, W, and FG) *1 *2	Rated current	A	1.5	2.9	4.7	6.7	9.4	16.5	22.0	33.1	
	Wire size	–	AWG14				AWG12		AWG6	AWG4	
	Screw size	–	–	–	–	–	M5			M6	
	Tightening torque	N·m	–	–	–	–	2.0		2.0 to 2.4	2.2 to 2.5	
Frame ground (FG)	Wire size	–	AWG14				AWG12		AWG6	AWG4	
	Screw size	–	M4				M5			M6	
	Tightening torque	N·m	1.2				2.0		1.4 to 1.6	2.4 to 2.8	
Dynamic brake resistor control terminals	Wire size	–	–						AWG18		
	Screw size	–							M5	M6	
	Tightening torque	N·m							1.3 to 1.5	0.7 to 0.8	

*1 Connect an OMRON power cable to the motor connection terminals.

*2 Use the same wire sizes for B1 and B2.

Wire Sizes and Allowable Current (Reference)

The following table shows the allowable current when there are 3 power supply wires. Use a current below these specified values.

● 600-V Heat-resistant Vinyl Wire (HIV)

AWG size	Nominal cross-sectional area (mm ²)	Configuration (wires/mm ²)	Conductive resistance (Ω/km)	Allowable current (A) for ambient temperature		
				30°C	40°C	50°C
20	0.5	19/0.18	39.5	6.6	5.6	4.5
–	0.75	30/0.18	26.0	8.8	7.0	5.5
18	0.9	37/0.18	24.4	9.0	7.7	6.0
16	1.25	50/0.18	15.6	12.0	11.0	8.5
14	2.0	7/0.6	9.53	23	20	16
12	3.5	7/0.8	5.41	33	29	24
10	5.5	7/1.0	3.47	43	38	31
8	8.0	7/1.2	2.41	55	49	40
6	14.0	7/1.6	1.35	79	70	57
4	22.0	7/2.0	0.85	99	88	70

Terminal Block Wiring Procedure

On a Servo Drive with 2.0 kW or less, connector-type terminal blocks are used.

The procedure for wiring these terminal blocks is explained below.

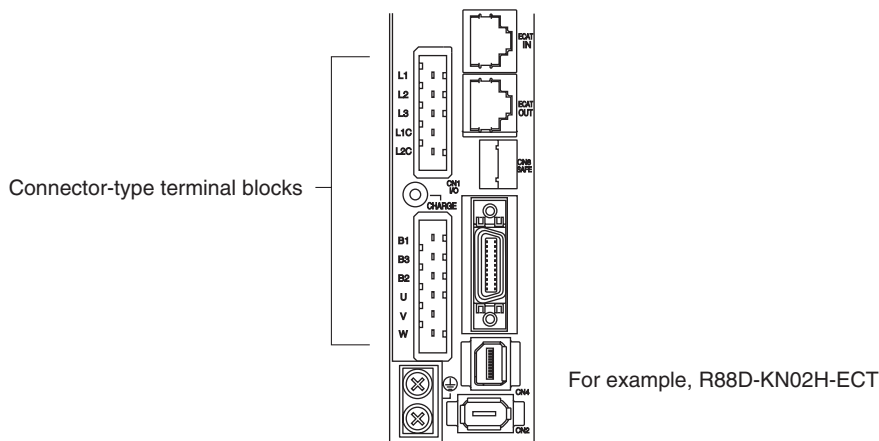

- 1 Remove the terminal block from the Servo Drive before wiring.
The Servo Drive may be damaged if the wiring is done with the terminal block in place.
- 2 Strip off 8 to 9 mm of the covering from the end of each wire.
Refer to *Terminal Block Wire Sizes* on page 4-30 for applicable wire sizes.

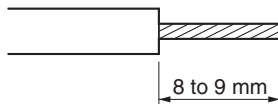

3 Open the wire insertion slots in the terminal block using a tool.

There are 2 ways to open the wire insertion slots, as follows.

- Pry the slot open using the lever that comes with the Servo Drive. (Figure A)
- Insert a flat-blade screwdriver (end width: 3.0 to 3.5 mm) into the opening for the driver on the terminal block, and press down firmly to open the slot. (Figure B)

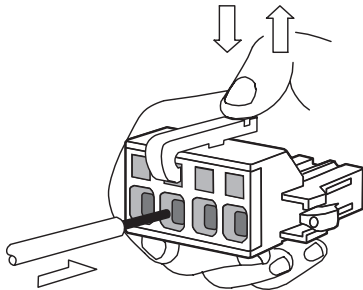

Figure A

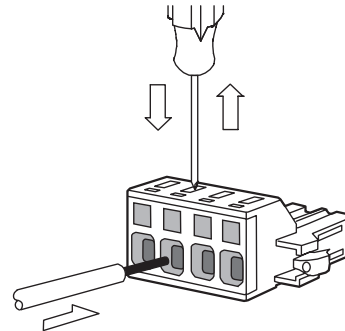

Figure B

4 With the wire insertion slot held open, insert the end of the wire.

After inserting the wire, let the slot close by releasing the pressure from the lever or the screwdriver.

5 Mount the terminal block to the Servo Drive.

After all of the terminals have been wired, return the terminal block to its original position on the Servo Drive.

Note The wire may not be inserted easily depending on the shape of the ferrule connected to it. If this occurs, perform one of the following methods before inserting the wire.

- Change the direction of inserting the connector by 90 degrees.
- Correct the shape of the ferrule with pliers.

4-3 Wiring Conforming to EMC Directives

Conformance to the EMC Directives (EN 55011 Class A Group 1 (EMI) and EN 61000-6-2 (EMS)) can be ensured by wiring under the conditions described in this section.

These conditions are for conformance of G5-series products to the EMC directives. EMC-related performance of these products, however, may be influenced by the configuration, wiring, and other conditions of the equipment in which the products are installed. The EMC conformance of the system as a whole must be confirmed by the customer.

The following are the requirements for EMC Directive conformance.

- The Servo Drive must be installed in a metal case (control panel). (The motor does not, however, have to be covered with a metal plate.)
- Noise filters and lightning surge absorptive elements (surge absorbers) must be installed on power supply lines.
- Braided shielded cables must be used for all I/O signal cables and encoder cables. (Use tin-plated, mild steel wires for the shielding.)
- All cables, I/O wiring, and power lines connected to the Servo Drive must have clamp cores installed.
- The shields of all cables must be directly connected to a ground plate.

4-3-1 Wiring Method

R88D-KNA5L-ECT/-KN01L-ECT/-KN02L-ECT/-KN04L-ECT/-KN01H-ECT/ -KN02H-ECT/-KN04H-ECT/-KN08H-ECT/-KN10H-ECT/-KN15H-ECT/ -KN20H-ECT/-KN30H-ECT/-KN50H-ECT/-KN75H-ECT/-KN150H-ECT

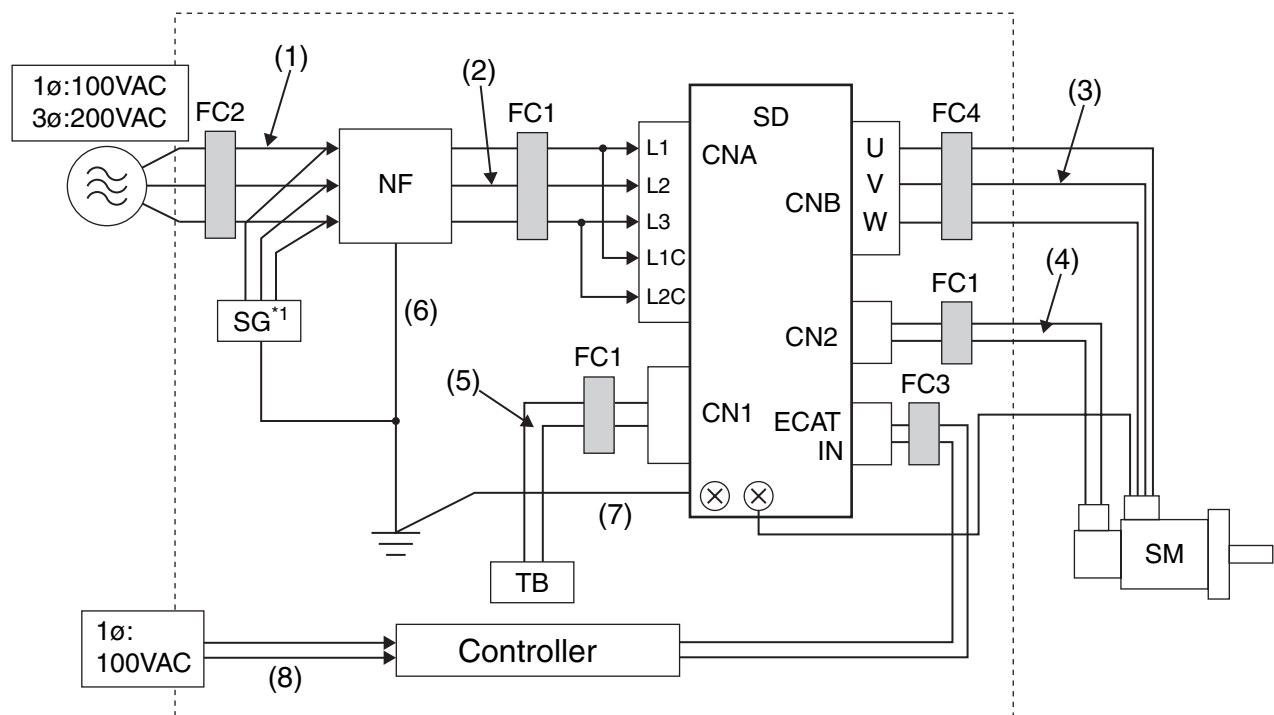

*1 Not required for single-phase models with a 100-VAC input.

Note For models with a single-phase power supply input (R88D-KNA5L-ECT/-KN01L-ECT/-KN02L-ECT/-KN04L-ECT/-KN01H-ECT/-KN02H-ECT/-KN04H-ECT/-KN08H-ECT), the main circuit power supply input terminals are L1 and L3.

- Ground the motor's frame to the machine ground when the motor is on a movable shaft.
- Use a ground plate for the frame ground for each unit, as shown in the above diagrams, and ground to a single point.
- Use ground lines with a minimum thickness of 3.5 mm², and arrange the wiring so that the ground lines are as short as possible.
- A no-fuse breaker, surge absorber, and noise filter should be positioned near the input terminal block (ground plate), and I/O lines should be separated and wired at the shortest distance.

● Unit Details

Symbol	Name	Manufacturer	Model	Comment
SG	Surge absorber	Okaya Electric Industries Co., Ltd.	R·A·V-781BXZ-4	3-phase 200 VAC
NF	Noise filter	Okaya Electric Industries Co., Ltd.	SUP-EK5-ER-6	Single-phase 100/200 VAC (5 A)
			3SUP-HU10-ER-6	3-phase 200 VAC (10 A)
			3SUP-HU30-ER-6	3-phase 200 VAC (30 A)
			3SUP-HL50-ER-6B	3-phase 200 VAC (50 A)
SD	Servo Drive	OMRON	–	*1
SM	Servomotor	OMRON	–	*1
FC1	Clamp core	TDK	ZCAT3035-1330	–
FC2	Clamp core	Konno Kogyosho	RJ8035	–
FC3	Clamp core	NEC TOKIN Corporation	ESD-SR-250	–
FC4	Clamp core	MICROMETALS	T400-61D	R88D-KN75H-ECT/-KN150H-ECT
		TDK	ZCAT3035-1330	Except for the above
TB	Switch box	–	–	–
-	Controller	–	–	–

*1 A specified combination of Servo Drive and Servomotor must be used.

R88D-KN75H-ECT/-KN150H-ECT (DC power input)

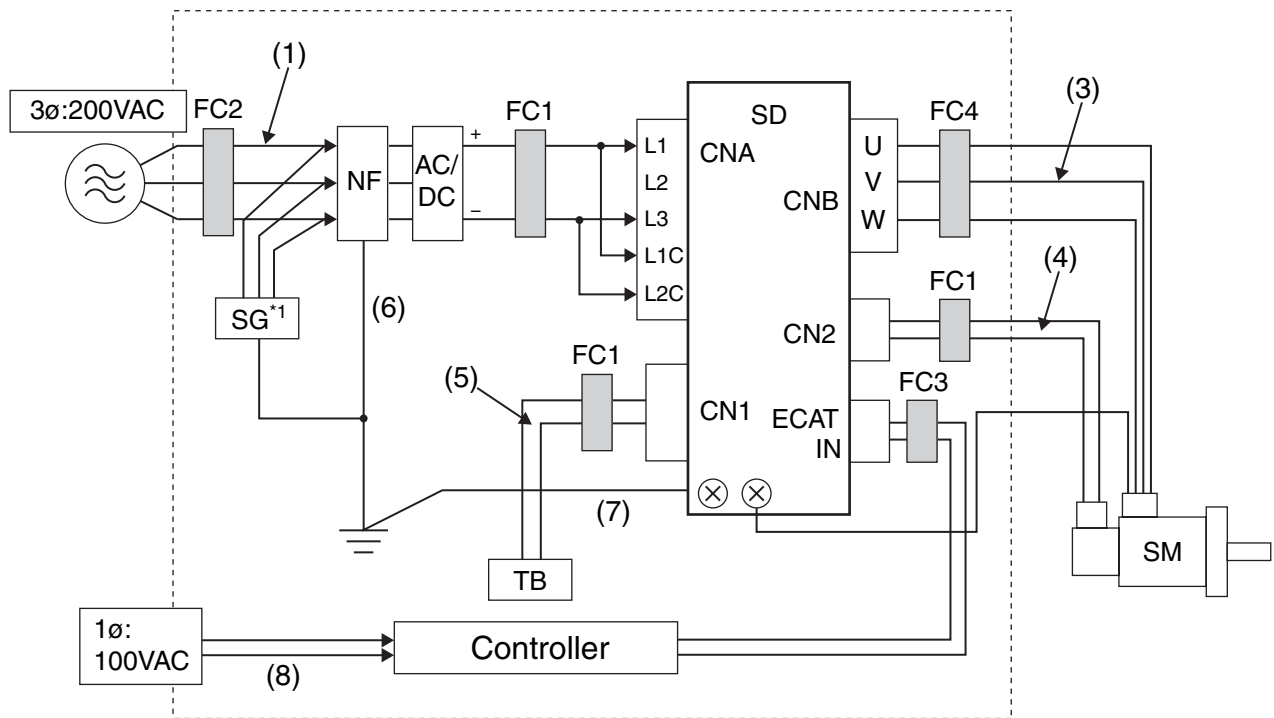

Note L1 and L3 are the main circuit power supply input terminals. Connect the positive wire to L1 and the negative wire to L3.

- Ground the motor's frame to the machine ground when the motor is on a movable shaft.
- Use a ground plate for the frame ground for each unit, as shown in the above diagrams, and ground to a single point.
- Use ground lines with a minimum thickness of 3.5 mm², and arrange the wiring so that the ground lines are as short as possible.
- A no-fuse breaker, surge absorber, and noise filter should be positioned near the input terminal block (ground plate), and I/O lines should be separated and wired at the shortest distance.

● Unit Details

Symbol	Name	Manufacturer	Model	Comment
SG	Surge absorber	Okaya Electric Industries Co., Ltd.	R·A·V-781BXZ-4	3 phase - 200 VAC
NF	Noise filter	Okaya Electric Industries Co., Ltd.	3SUP-HU30-ER-6	3 phase 200 VAC (30 A)
			3SUP-HL50-ER-6B	3 phase 200 VAC (50 A)
SD	Servo Drive	OMRON	—	*1
SM	Servomotor	OMRON	—	*1
FC1	Clamp core	TDK	ZCAT3035-1330	—
FC2	Clamp core	Konno Kogyosho	RJ8035	—
FC3	Clamp core	NEC TOKIN Corporation	ESD-SR-250	—
FC4	Clamp core	MICROMETALS	T400-61D	—
TB	Switch box	—	—	—
-	Controller	—	—	—

*1 A specified combination of Servo Drive and Servomotor must be used.

**R88D-KN06F-ECT/-KN10F-ECT/-KN15F-ECT/-KN20F-ECT/-KN30F-ECT/
-KN50F-ECT/-KN75F-ECT/-KN150F-ECT**

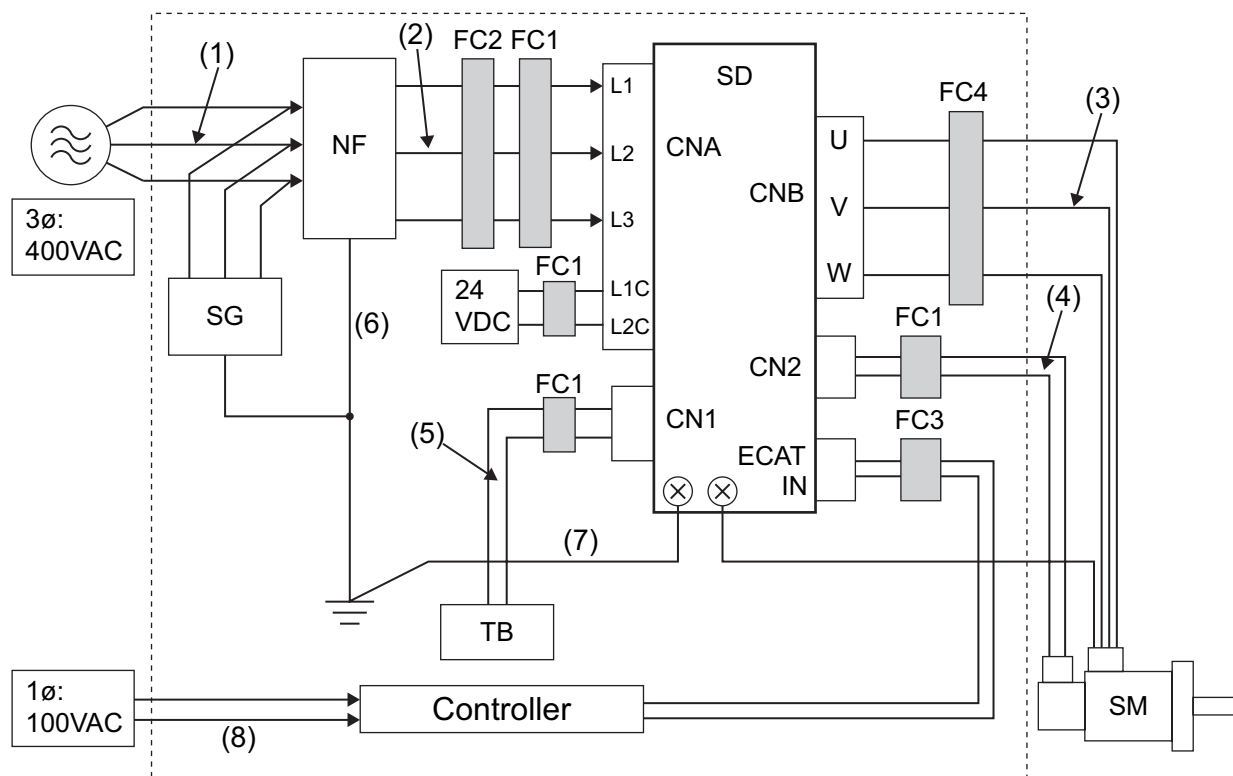

● Unit Details

Symbol	Name	Manufacturer	Model	Comment
SG	Surge absorber	Okaya Electric Industries Co., Ltd.	R·A·V-801BXZ-4	
NF	Noise filter	Okaya Electric Industries Co., Ltd.	3SUP-HQ10-ER-6	
			3SUP-HL50-ER-6B	
		Schaffner	FN258-42-07	
SD	Servo Drive	OMRON	-	*1
SM	Servomotor	OMRON	-	*1
FC1	Clamp core	TDK	ZCAT3035-1330	-
FC2	Clamp core	Konno Kogyosyo	RJ8035	-
FC3	Clamp core	NEC TOKIN Corporation	ESD-SR-250	-
FC4	Clamp core	MICROMETALS	T400-61D	R88D-KN75H-ECT/-KN150H-ECT
		TDK	ZCAT3035-1330	Except for the above
TB	Switch box	-	-	-
-	Controller	-	-	-

*1 A specified combination of Servo Drive and Servomotor must be used.

● Cable Details

Symbol	Supplies from	Connects to	Cable name	Length	Comment	Shielded	Ferrite
(1)	AC power supply	Noise filter	Power supply line	2 m	–	No	No
(2)	Noise filter	Servo Drive	Power supply line	2 m	–	No	Optional
(3)	Servo Drive	Servomotor	Power cable	20 m	–	No	Optional
(4)	Servo Drive	Servomotor	Encoder cable	20 m	–	Yes	Optional
(5)	Switch box	Servo Drive	I/O cable	2 m	–	No	Optional
(6)	Frame ground	Noise filter	FG line	1.5 m	–	No	No
(7)	Frame ground	Servo Drive	FG line	1.5 m	–	No	No
(8)	AC power supply	Controller	Power supply line	1.5 m	–	No	No

Noise Filter for Power Supply Input

We recommend using a noise filter for the Servo Drive.

Drive		Noise filter for power supply input			
Phase	Model	Model	Rated current	Leakage current (60 Hz) max	Manufacturer
Single-phase	R88D-K□A5L□□	SUP-EK5-ER-6	5 A	1.0 mA (at 250 VAC)	Okaya Electric Industries Co., Ltd.
	R88D-K□01L□□				
	R88D-K□02L□□				
Single-phase	R88D-K□04L□□	3SUP-HU10-ER-6	10 A	3.5 mA (at 500 VAC)	
Single-phase	R88D-K□01H□	SUP-EK5-ER-6	5 A	1.0 mA (at 250 VAC)	
3-phase		3SUP-HU10-ER-6	10 A	3.5 mA (at 500 VAC)	
Single-phase	R88D-K□02H□□	SUP-EK5-ER-6	5 A	1.0 mA (at 250 VAC)	
3-phase		3SUP-HU10-ER-6	10 A	3.5 mA (at 500 VAC)	
Single-phase	R88D-K□04H□□	SUP-EK5-ER-6	5 A	1.0 mA (at 250 VAC)	
3-phase		3SUP-HU10-ER-6	10 A	3.5 mA (at 500 VAC)	
Single-phase, 3-phase	R88D-K□08H□□	3SUP-HU30-ER-6	30 A	3.5 mA (at 500 VAC)	
	R88D-K□10H□□				
	R88D-K□15H□□				
3-phase	R88D-K□20H□□	3SUP-HU50-ER-6	50 A	8.0 mA (at 500 VAC)	
	R88D-K□30H□□	3SUP-HL50-ER-6B	50 A		
	R88D-K□50H□□				
	R88D-K□75H□□	FS5559-60-34	60 A	1.35 mA (at 480 VAC/50 Hz)	
	R88D-K□150H□□	FS5559-80-34	80 A		
	R88D-K□06F□□	FN258-16-07	16 A	0.8 mA (at 440 VAC/50 Hz)	
	R88D-K□10F□□				
	R88D-K□15F□□				
	R88D-K□20F□□				
R88D-K□30F□□	FN258-30-07	30 A	0.8 mA (at 440 VAC/50 Hz)		
R88D-K□50F□□					
R88D-K□75F□□	FN258-42-07	42 A	25.8 mA (at 440 VAC/50 Hz)		
R88D-K□150F□□					

- If no-fuse breakers are installed at the top and the power supply line is wired from the lower duct, use metal tubes for wiring or make sure that there is adequate distance between the input lines and the internal wiring. If input and output lines are wired together, noise resistance will decrease.
- The noise filter must be installed as close as possible to the entrance of the control panel. Wire as shown at the left in the following illustration.

○ Separate the input and output.

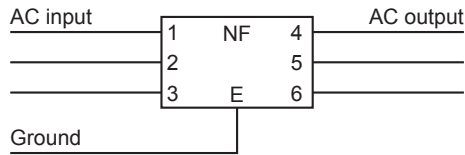

⊘ The effect of the noise filter is small.

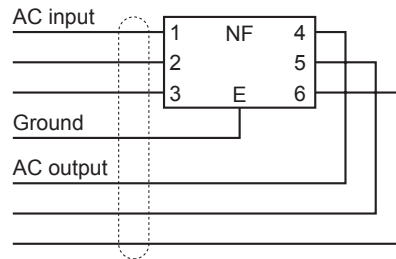

- Use twisted-pair cables for the power supply cables, or bind the cables.

○ Twisted-pair cables

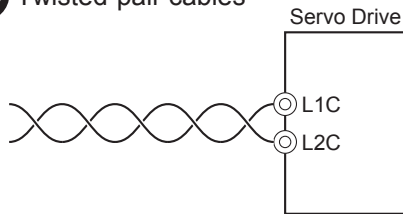

○ Bound cables

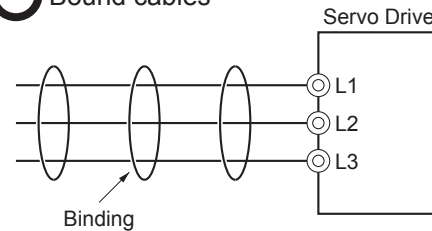

- Separate power supply lines and signal lines when wiring.

● External Dimensions

SUP-EK5-ER-6

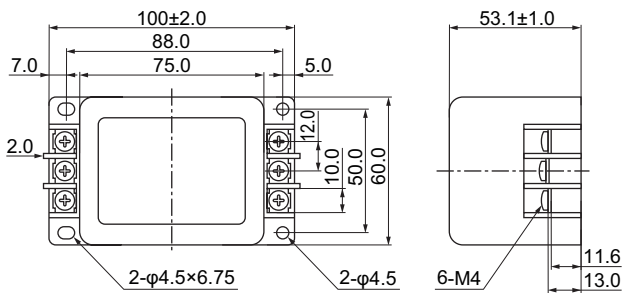

3SUP-HU10-ER-6

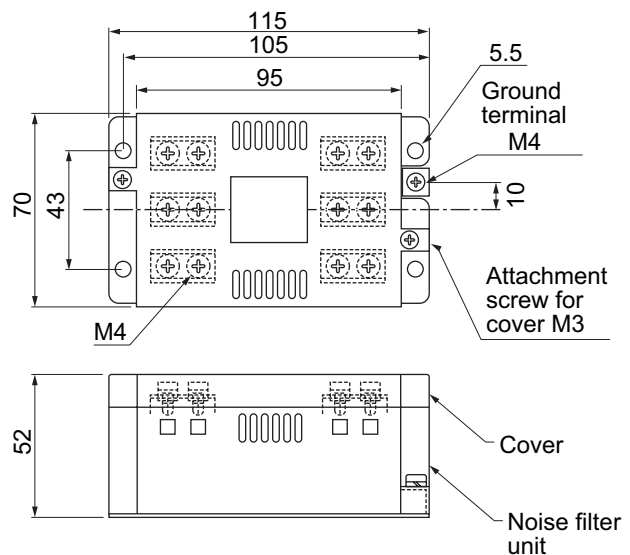

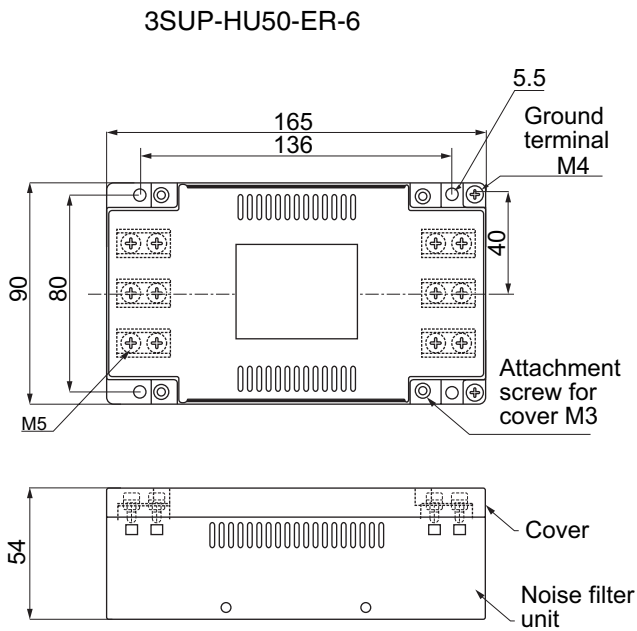
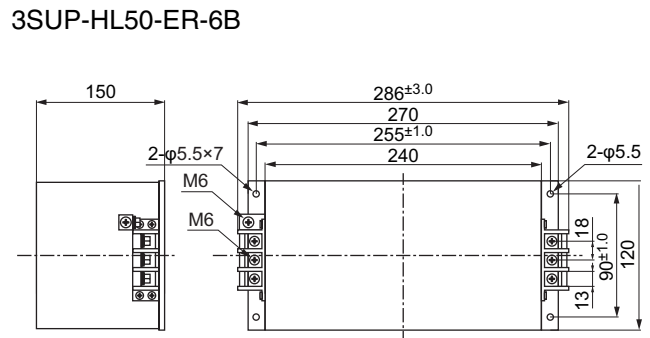
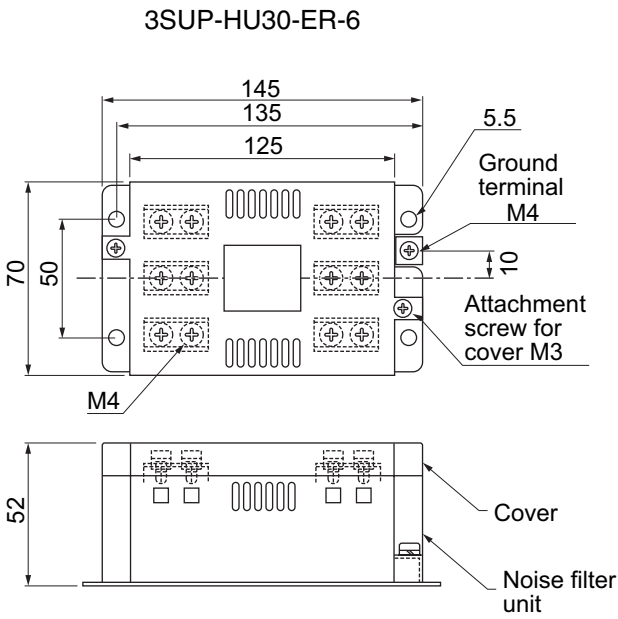

● **Circuit Diagram**

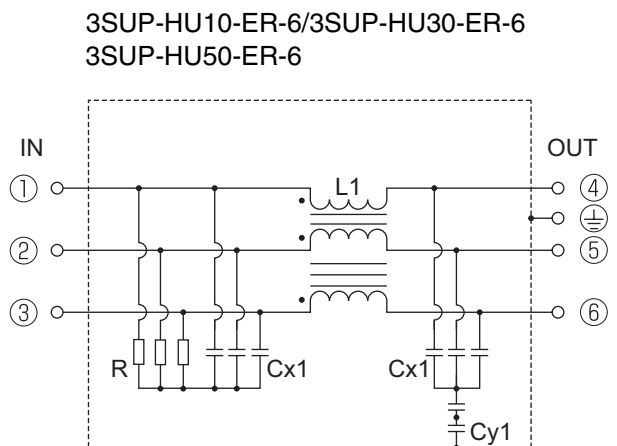
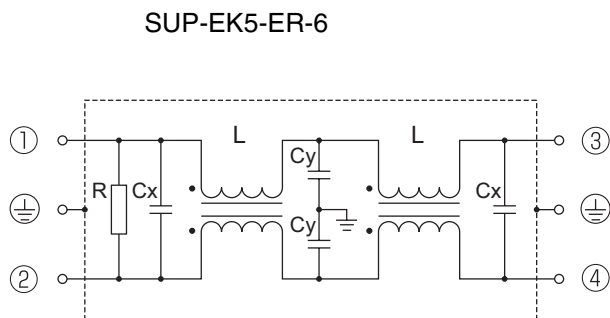

3SUP-HL50-ER-6B

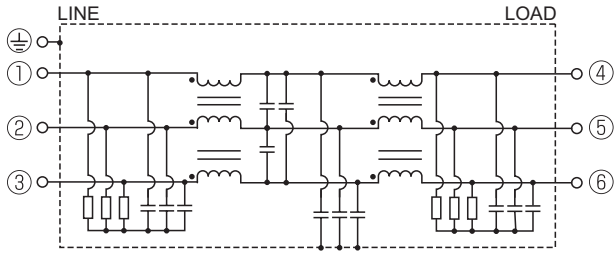

Control Panel Structure

Openings in the control panel, such as holes for cables, panel mounting holes, and gaps around the door, may allow electromagnetic waves into the panel. To prevent this, observe the recommendations described below when designing or selecting a control panel.

● Case Structure

- Use a metal control panel with welded joints at the top, bottom, and sides so that the surfaces are electrically conductive.
- If assembly is required, strip the paint off the joint areas (or mask them during painting), to make them electrically conductive.
- The panel may warp and gaps may appear when screws are tightened. Be sure that no gaps appear when tightening screws.
- Do not leave any conductive part unconnected.
- Ground all units within the case to the case itself.

● Door Structure

- Use a metal door.
- Use a water-draining structure where the door and case fit together, and leave no gaps. (Refer to the diagrams.)
- Use a conductive gasket between the door and the case. (Refer to the diagrams.)
- Strip the paint off the sections of the door and case that will be in contact with the conductive gasket (or mask them during painting), so that they are electrically conductive.
- The panel may warp and gaps may appear when screws are tightened. Be sure that no gaps appear when tightening screws.

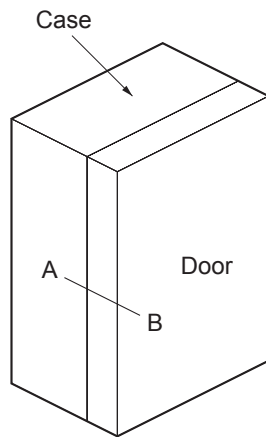

Control Panel

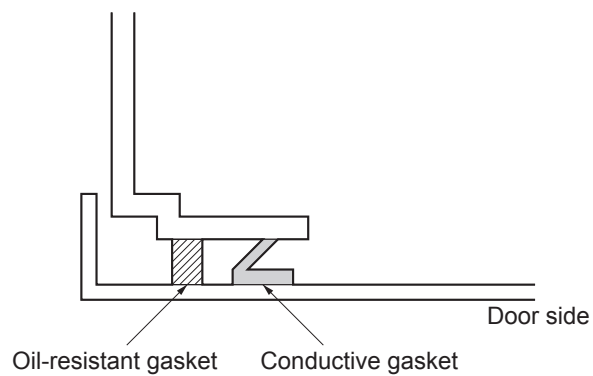

A-B Cross-section Diagram

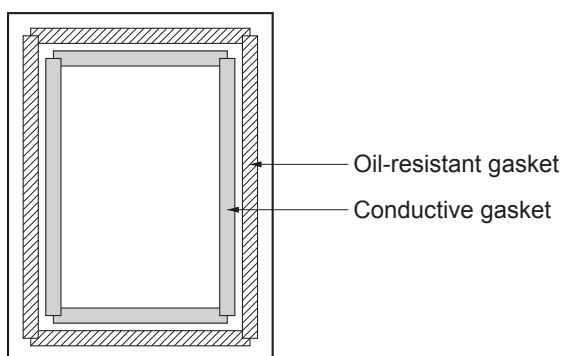

Door (Interior Side)

4-3-2 Selecting Connection Component

This section explains the criteria for selecting the connection components required to improve noise resistance.

Understand each component's characteristics, such as its capacity, performance, and applicable range when selecting the connection components.

For more details, contact the manufacturers directly.

No-fuse Breaker (NFB)

When selecting a no-fuse breaker, consider the maximum input current and the inrush current.

● Maximum Input Current

- The momentary maximum output of Servo Drive is approx. 3 times the rated output, and can be output for up to 3 seconds.
Therefore, select no-fuse breakers with an operation time of at least 5 seconds at 300% of the rated current ratio. General and low-speed no-fuse breakers are generally suitable.
- Select a no-fuse breaker with a rated current greater than the total effective load current of all the motors (when multiple Servo Drives are used). (The rated current of the power supply input for each motor is provided in *Main Circuit and Motor Connections* on page 4-21.)
- Add the current consumption of other controllers, and any other components when selecting.

● Inrush Current

- The following table lists the Servo Drive inrush currents.
- With low-speed no-fuse breakers, an inrush current 10 times the rated current can flow for 0.02 second.
- When the power of multiple Servo Drives are turned ON simultaneously, select a no-fuse breaker with a 20-ms allowable current that is greater than the total inrush current, shown in the following table.

Servo Drive model	Inrush current (Ao-p)	
	Main circuit power supply	Control circuit power supply
R88D-KNA5L-ECT	7	14
R88D-KN01L-ECT	7	14
R88D-KN02L-ECT	7	14
R88D-KN04L-ECT	15	14
R88D-KN01H-ECT	14	28
R88D-KN02H-ECT	14	28
R88D-KN04H-ECT	14	28
R88D-KN08H-ECT	29	28
R88D-KN10H-ECT	29	28
R88D-KN15H-ECT	29	28
R88D-KN20H-ECT	29	14
R88D-KN30H-ECT	22	14
R88D-KN50H-ECT	22	14
R88D-KN75H-ECT	66	15
R88D-KN150H-ECT	66	15
R88D-KN06F-ECT	28	48
R88D-KN10F-ECT	28	48

Servo Drive model	Inrush current (Ao-p)	
	Main circuit power supply	Control circuit power supply
R88D-KN15F-ECT	28	48
R88D-KN20F-ECT	32	48
R88D-KN30F-ECT	32	48
R88D-KN50F-ECT	32	48
R88D-KN75F-ECT	32	48
R88D-KN150F-ECT	32	48

Leakage Breaker

- Select a leakage breaker for high frequencies and surge resistance.
- When selecting leakage breakers, remember to add the leakage current from devices other than the motor, such as devices using a switching power supply, noise filters, inverters, and so on. To prevent malfunction due to inrush current, we recommend using a leakage breaker of 10 times the total of all leakage current values.
- The leakage breaker is activated at 50% of the rated current. Select a leakage breaker with approx. twice the capacity.
- For details on leakage breakers selection method, refer to the manufacturer's catalog.
- Because switching takes place inside the Servo Drives, high-frequency current leaks from the SW elements of the Servo Drive, the armature of the motor, and the cables. High-frequency, surge-resistant leakage breakers, because they do not detect high-frequency current, can prevent operation with high-frequency leakage current. When using a general leakage breaker, use 3 times the total of the leakage current given in the following table as a reference value.

Servo Drive model	Input power supply	Leakage current (Cable: 3 m)	Increase per 10 m of cable
R88D-KNA5L-ECT	Single-phase 100 V	0.38 mA	0.1 mA
R88D-KN01L-ECT	Single-phase 100 V	0.39 mA	
R88D-KN02L-ECT	Single-phase 100 V	0.41 mA	
R88D-KN04L-ECT	Single-phase 100 V	0.46 mA	0.12 mA
R88D-KN01H-ECT	Single-phase 200 V	0.83 mA	0.23 mA
	3-phase 200 V	1.03 mA	
R88D-KN02H-ECT	Single-phase 200 V	0.84 mA	0.23 mA
	3-phase 200 V	1.02 mA	
R88D-KN04H-ECT	Single-phase 200 V	0.96 mA	0.3 mA
	3-phase 200 V	1.27 mA	
R88D-KN08H-ECT	Single-phase 200 V	1.01 mA	1.1 mA
	3-phase 200 V	1.39 mA	
R88D-KN10H-ECT	Single-phase 200 V	0.88 mA	0.93 mA
	3-phase 200 V	1.14 mA	
R88D-KN15H-ECT	Single-phase 200 V	0.96 mA	0.93 mA
	3-phase 200 V	1.18 mA	
R88D-KN20H-ECT	3-phase 200 V	1.53 mA	1.23 mA
R88D-KN30H-ECT	3-phase 200 V	1.52 mA	
R88D-KN50H-ECT	3-phase 200 V	1.39 mA	
R88D-KN75H-ECT	3-phase 200 V	3.50 mA	2.07 mA
R88D-KN150H-ECT	3-phase 200 V	5.30 mA	1.13 mA

Servo Drive model	Input power supply	Leakage current (Cable: 3 m)	Increase per 10 m of cable
R88D-KN06F-ECT	3-phase 400 V	2.28 mA	1.8 mA
R88D-KN10F-ECT	3-phase 400 V	2.20 mA	
R88D-KN15F-ECT	3-phase 400 V	2.55 mA	2.03 mA
R88D-KN20F-ECT	3-phase 400 V	2.92 mA	2.4 mA
R88D-KN30F-ECT	3-phase 400 V	3.92 mA	3.23 mA
R88D-KN50F-ECT	3-phase 400 V	3.54 mA	2.9 mA
R88D-KN75F-ECT	3-phase 400 V	6.70 mA	3.73 mA
R88D-KN150F-ECT	3-phase 400 V	10.40 mA	2.73 mA

Note These values vary greatly depending on the installation conditions of the motor power cable and the measurement conditions. Use the values for reference only.

Surge Absorber

- Use surge absorbers to absorb lightning surge voltage and abnormal voltage from power supply input lines.
- When selecting surge absorbers, take into account the varistor voltage, the surge immunity and the energy tolerated dose.
- For 200-VAC systems, use surge absorbers with a varistor voltage of 620 V.
- The surge absorbers shown in the following table are recommended.

Manufacturer	Model	Surge immunity		Type	Comment
Okaya Electric Industries Co., Ltd.	R·A·V-781BWZ-4	700 V ± 20%	2500 A	Block	Single-phase 100/200 VAC
Okaya Electric Industries Co., Ltd.	R·A·V-781BXZ-4	700 V ± 20%	2500 A		3-phase 200 VAC
Okaya Electric Industries Co., Ltd.	R·A·V-801BXZ-4	800V ± 20%	2500 A		3-phase 400 VAC

Note 1 Refer to the manufacturers' catalog for operating details.

- 2 The surge immunity is for a standard impulse current of 8/20 μ s. If pulses are wide, either decrease the current or change to a larger-capacity surge absorber.

● External Dimensions

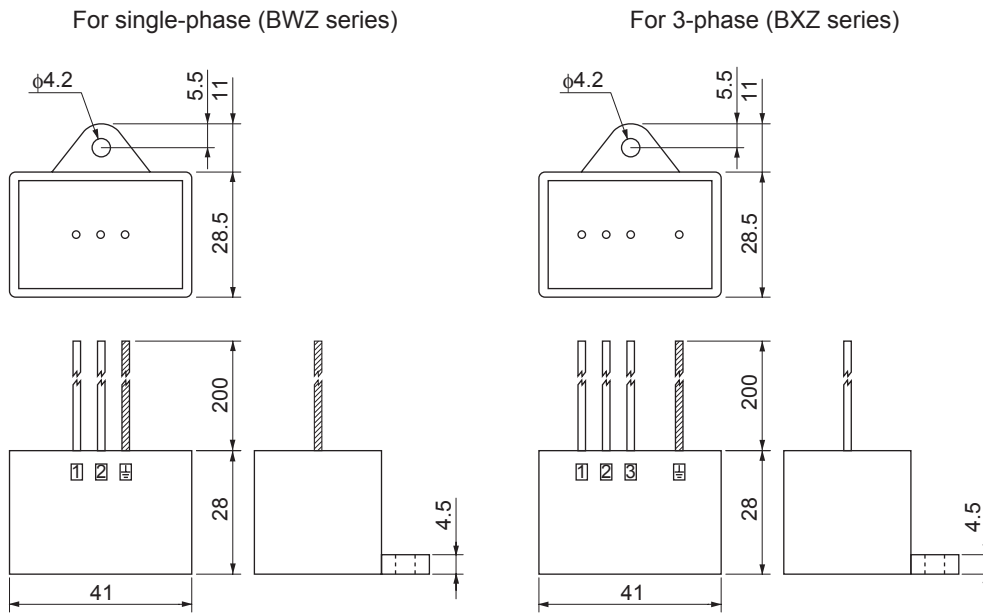

● Equalizing Circuits

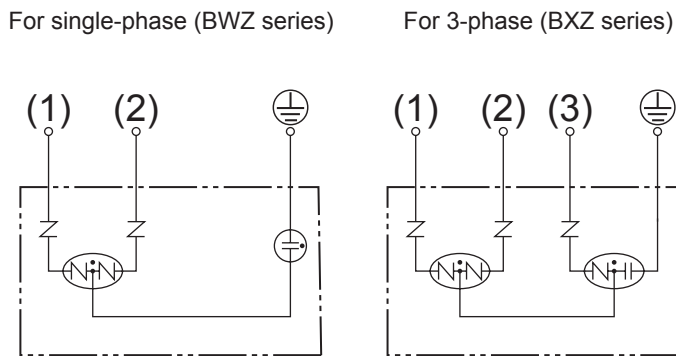

Noise Filter for the Brake Power Supply

- Use the following noise filter for the brake power supply.

Model	Rated current	Rated voltage	Leakage current	Manufacturer
SUP-EK5-ER-6	5 A	250 V	1.0 mA (at 250 Vrms, 60 Hz)	Okaya Electric Industries Co., Ltd.

Note Noise can also be reduced by 1.5 turns with the ZCAT3035-1330 (TDK) Clamp Core.

Radio Noise Filter and Emission Noise Prevention Clamp Core

Use one of the following filters to prevent switching noise of PWM of the Servo Drive and to prevent noise emitted from the internal clock circuit.

Model	Manufacturer	Application
3G3AX-ZCL1 *1	OMRON	For Drive output and power cable
3G3AX-ZCL2 *2	OMRON	For Drive output and power cable
ESD-R-47B *3	NEC TOKIN	For Drive output and power cable
ZCAT3035-1330 *4	TDK	For Encoder cable and I/O cable
RJ8035	Konno Kogyosho	For power supply line
RJ8095	Konno Kogyosho	For power supply line
T400-61D	MICROMETALS	For Drive output and power cable

*1 Generally used for 1.5 kW or higher.

*2 Generally used for 1.5 kW or lower. The maximum number of windings is 3 turns.

*3 Generally used for 50/100 W. The maximum number of windings is 2 turns.

*4 Also used on the Drive output power lines to comply with the EMC Directives. Only a clamp is used. This clamp can also be used to reduce noise current on a FG line.

External Dimensions

3G3AX-ZCL1

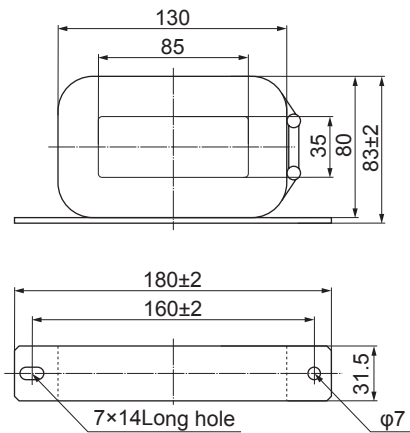

3G3AX-ZCL2

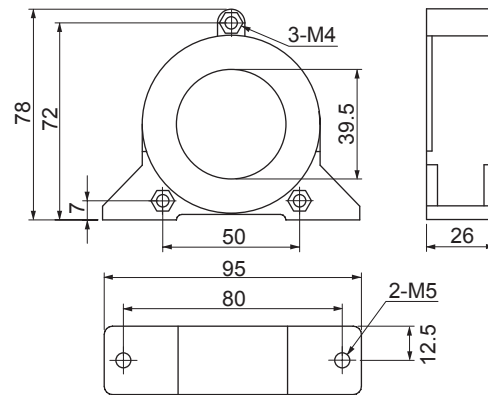

ESD-R-47B

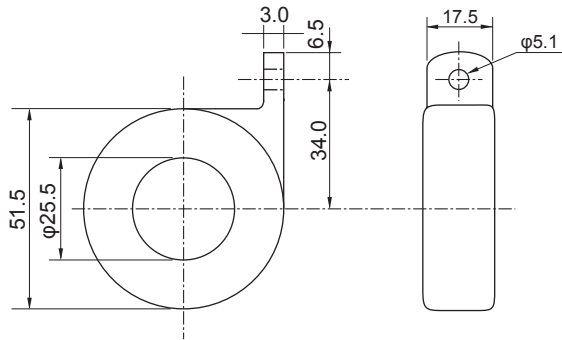

ZCAT3035-1330

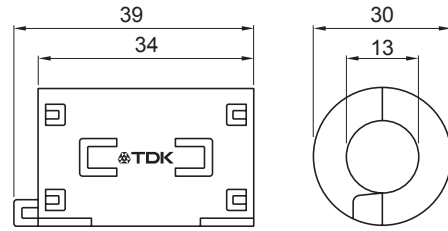

RJ8035/RJ8095

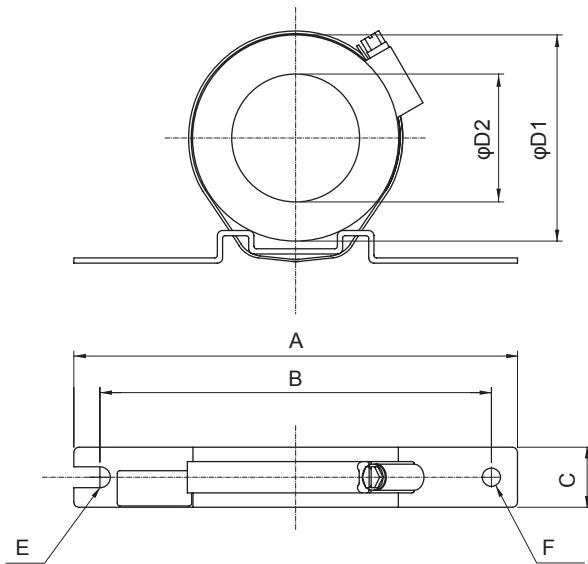

T400-61D

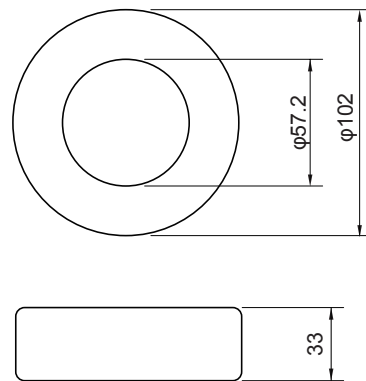

Model	Rated current	Dimensions (mm)							
		A	B	C	D1	D2	Core thickness	E	F
RJ8035	35A	170	150	23	80	53	24	R3.5	7
RJ8095	95A	200	180	34	130	107	35	R3.5	7

● Impedance Characteristics

3G3AX-ZCL1

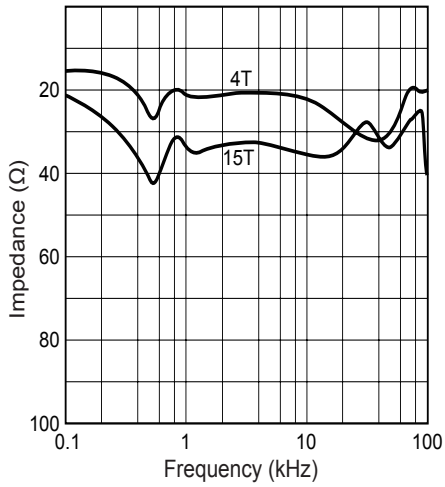

3G3AX-ZCL2

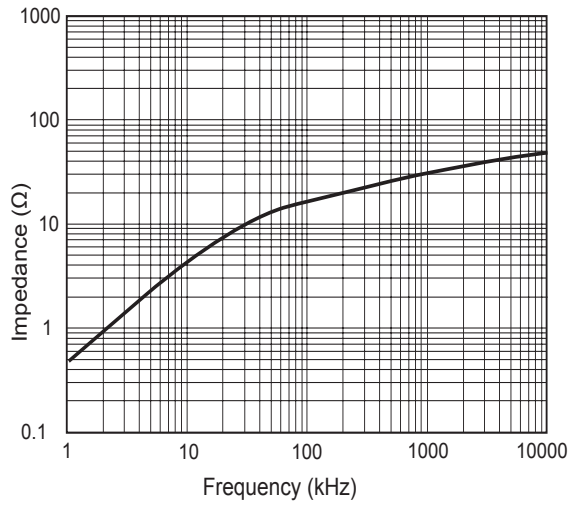

ESD-R-47B

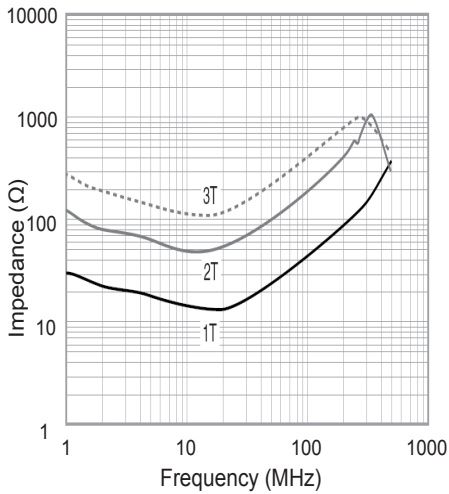

ZCAT3035-1330

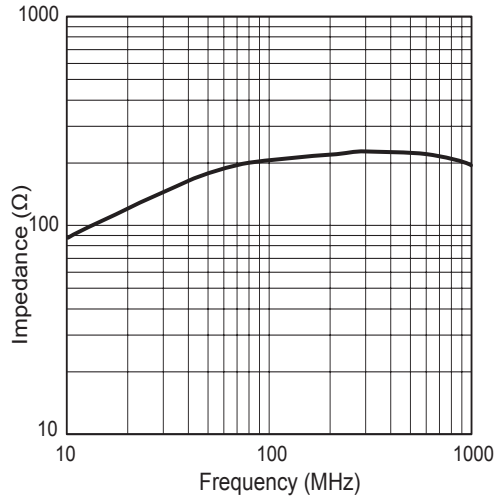

RJ8035

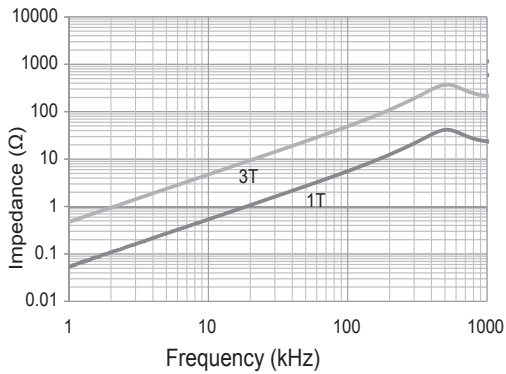

RJ8095

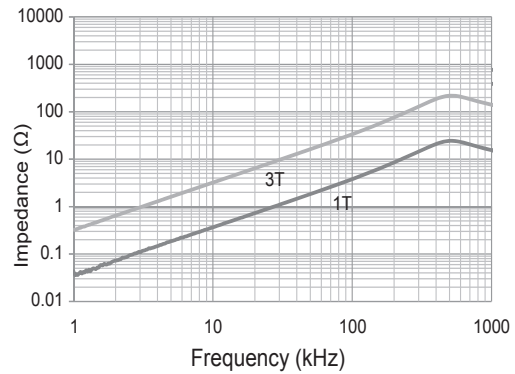

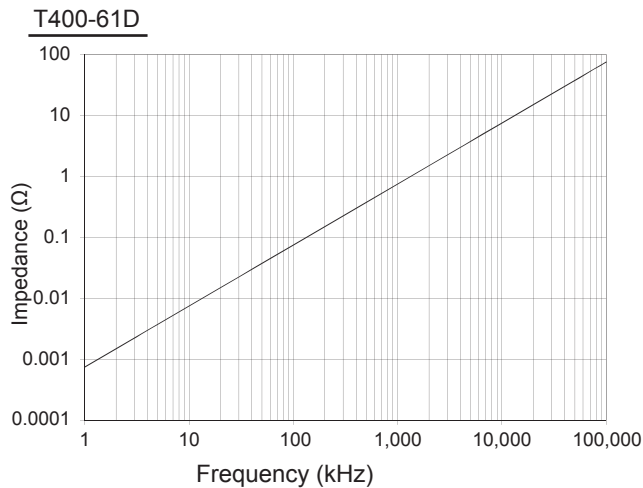

Surge Suppressors

- Install surge suppressors for loads that have induction coils, such as relays, solenoids, brakes, clutches, etc.
- The following table shows the types of surge suppressors and recommended products.

Type	Feature	Recommended product
Diodes	Diodes are used for relatively small loads such as relays when the reset time is not a critical issue. At power shutoff the surge voltage is the lowest, but the reset time takes longer. Used for 24/48-VDC systems.	Use a fast-recovery diode with a short reverse recovery time. (e.g. RU2 of Sanken Electric Co., Ltd.).
Thyristors and varistors	Thyristors and varistors are used for loads when induction coils are large, as in electromagnetic brakes, solenoids, etc., and when reset time is critical. The surge voltage at power shutoff is approx. 1.5 times the varistor voltage.	Select the varistor voltage as follows. 24-VDC systems: varistor voltage 39 V 100-VDC systems: varistor voltage 200 V 100-VAC systems: varistor voltage 270 V 200-VAC systems: varistor voltage 470 V
Capacitor + resistor	The capacitor plus resistor combination is used to absorb vibration in the surge at power supply shutoff. The reset time can be shortened by selecting the appropriate capacitance and resistance.	Okaya Electric Industries Co., Ltd. XEB12002 0.2 μ F-120 Ω XEB12003 0.3 μ F-120 Ω

- Thyristors and varistors are made by the following manufacturers. Refer to manufacturer's documentation for details on these components.

Thyristors: Ishizuka Electronics Co.

Varistor: Ishizuka Electronics Co., Panasonic Corporation

Contactors

- Select contactors based on the circuit's inrush current and the maximum momentary phase current.
- The drive inrush current is covered in the preceding explanation of no-fuse breaker selection. And the maximum momentary phase current is approx. twice the rated current.

Improving Encoder Cable Noise Resistance

Take the following steps during wiring and installation to improve the encoder's noise resistance.

- Always use the specified encoder cables.
- If cables are joined midway, be sure to use connectors. And do not remove more than 50 mm of the cable insulation. In addition, always use shielded cables.
- Do not roll cables. If cables are long and are rolled, mutual induction and inductance will increase and cause malfunctions. Always use cables fully extended.
- When installing noise filters for encoder cables, use clamp cores.
- The following table shows the recommended clamp cores.

Manufacturer	Product name	Model	Specifications
NEC TOKIN	Clamp core	ESD-SR-250	13 mm dia. max.
TDK	Clamp core	ZCAT3035-1330	13 mm dia. max.

- Do not place the encoder cable with the following cables in the same duct.
Control cables for brakes, solenoids, clutches, and valves.

External Dimensions

ESD-SR-250

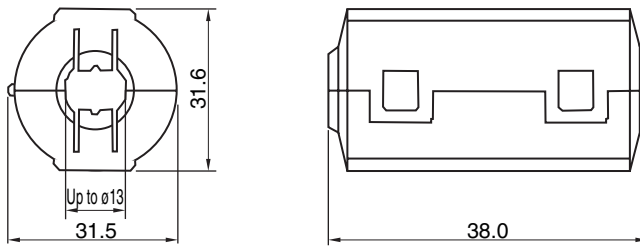

Impedance Characteristics

ESD-SR-250

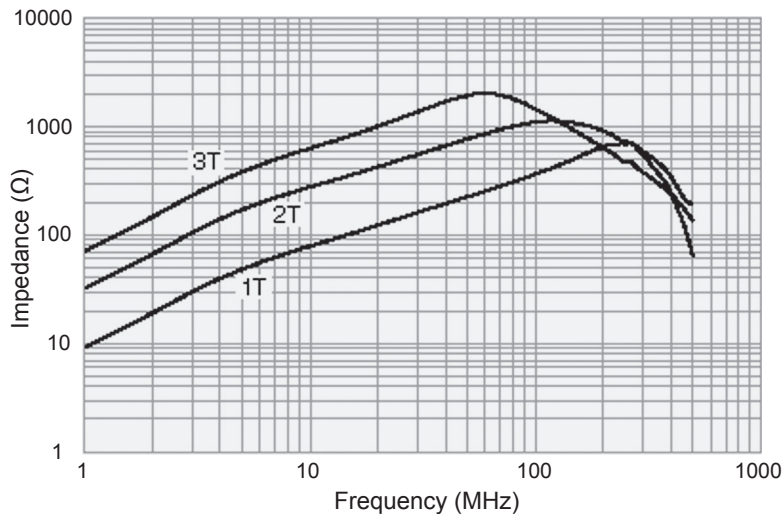

For information on an external dimensions and impedance characteristics of ZCAT3035-1330, refer to *External Dimensions* on page 4-48 and *Impedance Characteristics* on page 4-50.

Improving Control I/O Signal Noise Resistance

Positioning can be affected and I/O signal errors can occur if control I/O is influenced by noise.

- Use completely separate power supplies for the control I/O power supply (especially 24 VDC) and the external operation power supply. In particular, do not connect the 2 power supply ground wires.
- Install a noise filter on the primary side of the control I/O power supply.
- If motors with brakes are being used, do not use the same 24-VDC power supply for both the brakes and the control I/O. Additionally, do not connect the ground wires. Connecting the ground wires may cause I/O signal errors.
- If the control I/O power supply wiring is long, noise resistance can be improved by adding 1- μ F laminated ceramic capacitors between the control I/O power supply and ground at the drive input section or the controller output section.

Reactor to Reduce Harmonic Current

● Harmonic Current Measures

- Use a Reactor to suppress harmonic currents. The Reactor functions to suppress sudden and quick changes in electric currents.
- *The Guidelines for Suppressing Harmonic Currents in Home Appliances and General Purpose Components* requires that manufacturers take appropriate remedies to suppress harmonic current emissions onto power supply lines.
- Select the proper Reactor model according to the Servo Drive to be used.

Servo Drive		Reactor			
Model	Number of power phases	Model	Rated current	Inductance	Weight
R88D-K□A5L-□	Single-phase	3G3AX-DL2002	1.6 A	21.4 mH	Approx. 0.8 kg
R88D-K□01L-□		3G3AX-DL2004	3.2 A	10.7 mH	Approx. 1.0 kg
R88D-K□02L-□		3G3AX-DL2007	6.1 A	6.75 mH	Approx. 1.3 kg
R88D-K□04L-□		3G3AX-DL2015	9.3 A	3.51 mH	Approx. 1.6 kg
R88D-K□01H-□	Single-phase	3G3AX-DL2002	1.6 A	21.4 mH	Approx. 0.8 kg
	Three-phase	3G3AX-AL2025	10.0 A	2.8 mH	Approx. 2.8 kg
R88D-K□02H-□	Single-phase	3G3AX-DL2004	3.2 A	10.7 mH	Approx. 1.0 kg
	Three-phase	3G3AX-AL2025	10.0 A	2.8 mH	Approx. 2.8 kg
R88D-K□04H-□	Single-phase	3G3AX-DL2007	6.1 A	6.75 mH	Approx. 1.3 kg
	Three-phase	3G3AX-AL2025	10.0 A	2.8 mH	Approx. 2.8 kg
R88D-K□08H-□	Single-phase	3G3AX-DL2015	9.3 A	3.51 mH	Approx. 1.6 kg
	Three-phase	3G3AX-AL2025	10.0 A	2.8 mH	Approx. 2.8 kg
R88D-K□10H-□	Single-phase	3G3AX-DL2015	9.3 A	3.51 mH	Approx. 1.6 kg
	Three-phase	3G3AX-AL2025	10.0 A	2.8 mH	Approx. 2.8 kg
R88D-K□15H-□	Single-phase	3G3AX-DL2022	13.8 A	2.51 mH	Approx. 2.1 kg
	Three-phase	3G3AX-AL2025	10.0 A	2.8 mH	Approx. 2.8 kg

Servo Drive		Reactor			
Model	Number of power phases	Model	Rated current	Inductance	Weight
R88D-K□20H-□	Three-phase	3G3AX-AL2055	20.0 A	0.88 mH	Approx. 4.0 kg
R88D-K□30H-□					
R88D-K□50H-□		3G3AX-AL2110	37.0 A	0.35 mH	Approx. 5.0 kg
R88D-K□75H-□		3G3AX-AL2220	70.0 A	0.18 mH	Approx. 10.0 kg
R88D-K□150H-□					
R88D-K□06F-□		3G3AX-AL4025	6.0 A	7.7 mH	Approx. 2.7 kg
R88D-K□10F-□					
R88D-K□15F-□					
R88D-K□20F-□		3G3AX-AL4055	10.0 A	3.5 mH	Approx. 4.0 kg
R88D-K□30F-□					
R88D-K□50F-□		3G3AX-AL4110	20.0 A	1.3 mH	Approx. 6.0 kg
R88D-K□75F-□		3G3AX-AL4220	36.0 A	0.74 mH	Approx. 10.0 kg
R88D-K□150F-□					

Selecting Other Parts for Noise Resistance

This section explains the criteria for selecting the connection components required to improve noise resistance.

Understand each component's characteristics, such as its capacity, performance, and applicable range when selecting the connection components.

For more details, contact the manufacturers directly.

● Noise Filters for Motor Output

- Use noise filters without built-in capacitors on the motor output lines.
- Select a noise filter with a rated current at least twice the Servo Drive's continuous output current.
- The following table shows the noise filters that are recommended for motor output lines.

Manufacturer	Model	Rated current	Comment
OMRON	3G3AX-NFO01	6 A	For inverter output
	3G3AX-NFO02	12 A	
	3G3AX-NFO03	25 A	
	3G3AX-NFO04	50 A	
	3G3AX-NFO05	75 A	
	3G3AX-NFO06	100 A	

Note 1 Motor output lines cannot use the same noise filters for power supplies.

- 2 General noise filters are made for power supply frequencies of 50/60 Hz. If these noise filters are connected to output of the Servo Drive, a very large (about 100 times larger) leakage current may flow through the noise filter's capacitor. This may damage the Servo Drive.

● External Dimensions

3G3AX-NFO01/-NFO02

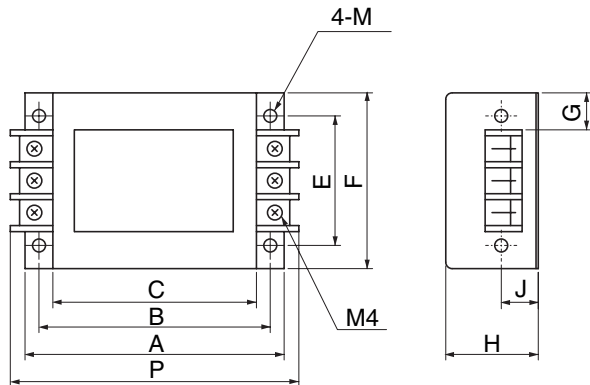

Model	Dimensions (mm)									
	A	B	C	E	F	G	H	J	M	P
3G3AX-NFO01	140	125	110	70	95	22	50	20	4.5 dia.	156
3G3AX-NFO02	160	145	130	80	110	30	70	25	5.5 dia.	176

3G3AX-NFO03/-NFO04/-NFO05/-NFO06

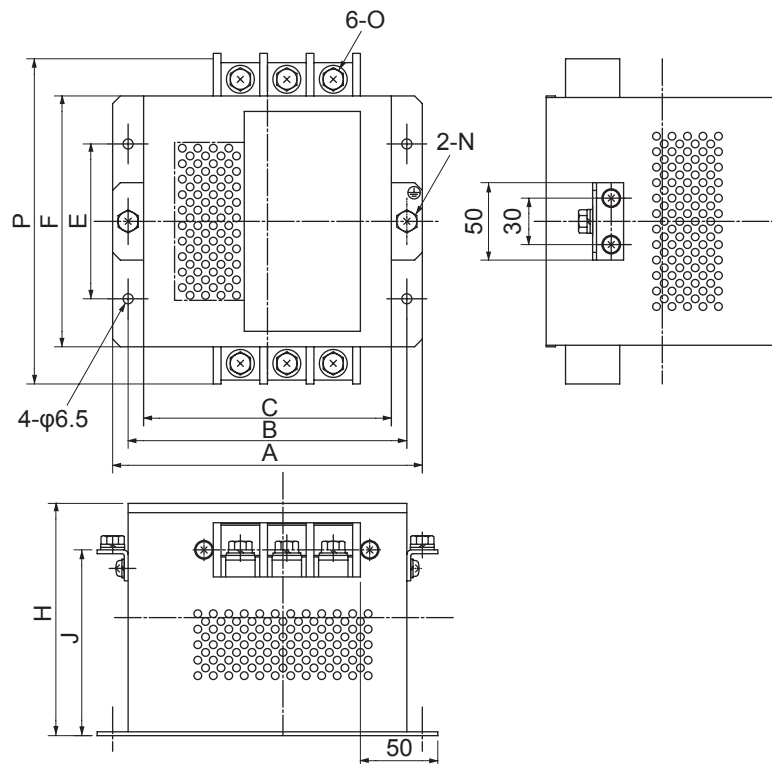

Model	Dimensions (mm)									
	A	B	C	E	F	H	J	N	O	P
3G3AX-NFO03	160	145	130	80	112	120	-	-	M4	154
3G3AX-NFO04	200	180	160	100	162	150	120	M5	M5	210
3G3AX-NFO05	220	200	180	100	182	170	140	M6	M6	230
3G3AX-NFO06	220	200	180	100	182	170	140	M8	M8	237

4-4 Regenerative Energy Absorption

The Servo Drives have internal regeneration process circuitry, which absorbs the regenerative energy produced during motor deceleration and prevents the DC voltage from increasing. An overvoltage error occurs, however, if the amount of regenerative energy from the motor is too large. If this occurs, remedies must be taken to reduce the regenerative energy by changing operating patterns, or to increase the regeneration process capacity by connecting an External Regeneration Unit.

4-4-1 Calculating the Regenerative Energy

Horizontal Axis

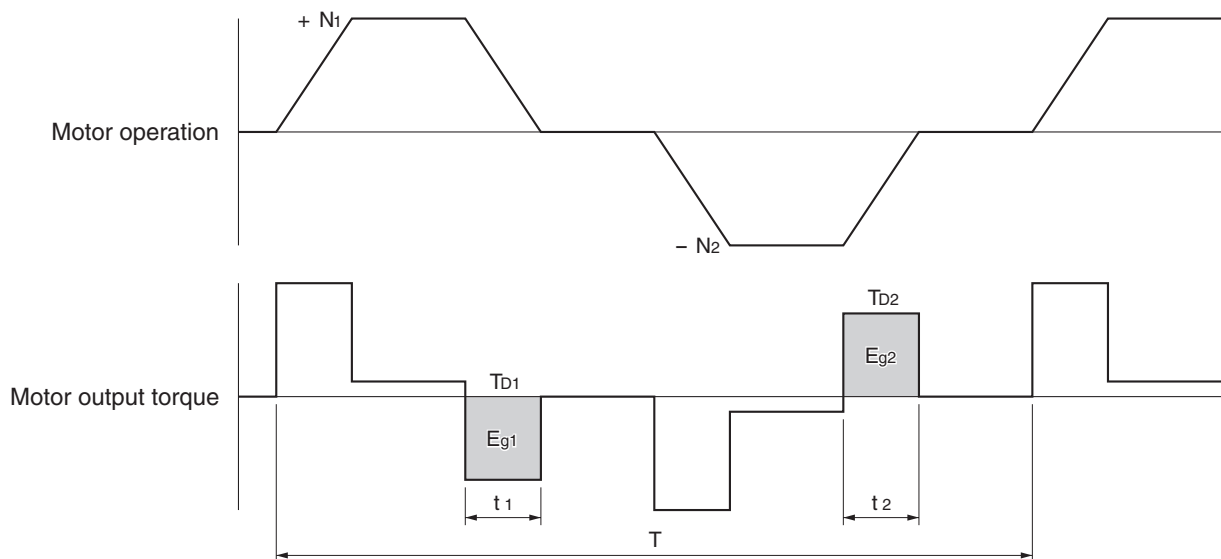

- In the output torque graph, acceleration in the forward direction is shown as positive, and acceleration in the reverse direction is shown as negative.
- The regenerative energy values in each region can be derived from the following equations.

$$\cdot E_{g1} = \frac{1}{2} \cdot \frac{2\pi}{60} \cdot N_1 \cdot T_{D1} \cdot t_1 \quad [\text{J}]$$

$$\cdot E_{g2} = \frac{1}{2} \cdot \frac{2\pi}{60} \cdot N_2 \cdot T_{D2} \cdot t_2 \quad [\text{J}]$$

N_1, N_2 : Rotation speed at start of deceleration [r/min]

T_{D1}, T_{D2} : Deceleration torque [N·m]

t_1, t_2 : Deceleration time [s]

Note Due to the loss of motor winding resistance and PWM, the actual regenerative energy will be approx. 90% of the values derived from these equations.

- For Servo Drive models with internal capacitors used for absorbing regenerative energy (i.e., Servo Drive models of 400 W or less), the values E_{g1} and E_{g2} (unit: J) must be lower than the drive's regeneration absorption capacity. (The capacity depends on the model. For details, refer to the next section.)
- For Servo Drive models with an Internal Regeneration Resistor used for absorbing regenerative energy (i.e., Servo Drive models of 500 W or more), the average amount of regeneration P_r (unit: W) must be calculated, and this value must be lower than the drive's regeneration absorption capacity. (The capacity depends on the model. For details, refer to the next section.)

The average regeneration power (P_r) is the regeneration power produced in 1 cycle of operation [W].

$$P_r = (E_{g1} + E_{g2}) / T [W]$$

T: Operation cycle [s]

Vertical Axis

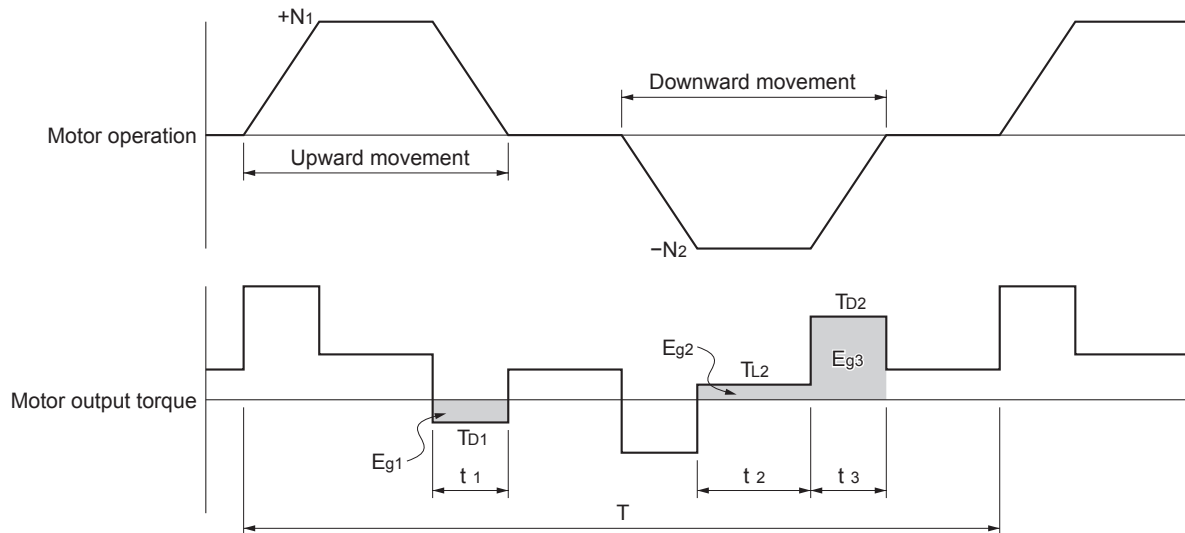

- In the output torque graph, acceleration in the forward direction (rising) is shown as positive, and acceleration in the reverse direction (falling) is shown as negative.
- The regenerative energy values in each region can be derived from the following equations.

$$E_{g1} = \frac{1}{2} \cdot \frac{2\pi}{60} \cdot N_1 \cdot T_{D1} \cdot t_1 \quad [J]$$

$$E_{g2} = \frac{2\pi}{60} \cdot N_2 \cdot T_{L2} \cdot t_2 \quad [J]$$

$$E_{g3} = \frac{1}{2} \cdot \frac{2\pi}{60} \cdot N_2 \cdot T_{D2} \cdot t_3 \quad [J]$$

N_1, N_2 : Rotation speed at start of deceleration [r/min]

T_{D1}, T_{D2} : Deceleration torque [N·m]

T_{L2} : Torque during downward movement [N·m]

t_1, t_3 : Deceleration time [s]

t_2 : Constant-speed driving time during downward movement [s]

Note Due to the loss of winding resistance, the actual regenerative energy will be approx. 90% of the values derived from these equations.

- For Servo Drive models with internal capacitors used for absorbing regenerative energy (i.e., Servo Drive models of 400 W or less), the values E_{g1} and $E_{g2} + E_{g3}$ (unit: J) must be lower than the drive's regeneration absorption capacity. (The capacity depends on the model. For details, refer to the next section.)
- For Servo Drive models with an Internal Regeneration Resistor used for absorbing regenerative energy (i.e., Servo Drive models of 500 W or more), the average amount of regeneration P_r (unit: W) must be calculated, and this value must be lower than the drive's regeneration absorption capacity. (The capacity depends on the model. For details, refer to the next section.)

The average regeneration power (P_r) is the regeneration power produced in 1 cycle of operation [W].

$$P_r = (E_{g1} + E_{g2} + E_{g3}) / T [W]$$

T: Operation cycle [s]

4-4-2 Servo Drive Regeneration Absorption Capacity

Amount of Internal Regeneration Absorption in Servo Drives

This Servo Drive absorbs regenerative energy internally with built-in capacitors.

If the regenerative energy is too large to be processed internally, an overvoltage error occurs and operation cannot continue.

The following table shows the regenerative energy (and amount of regeneration) that each drive can absorb. If these values are exceeded, take the following processes.

- Connect an External Regeneration Resistor. (Regeneration process capacity improves.)
- Reduce the operating rotation speed. (The amount of regeneration is proportional to the square of the rotation speed.)
- Lengthen the deceleration time. (Regenerative energy per unit time decreases.)
- Lengthen the operation cycle, i.e., the cycle time. (Average regenerative power decreases.)

Servo Drive model	Regenerative energy absorbable by built-in capacitor (J)	Internal regeneration resistor	Allowable minimum regeneration resistance (Ω)
		Average amount of regenerative energy absorbable (W)	
R88D-KNA5L-ECT	11	–	17
R88D-KN01L-ECT	11	–	17
R88D-KN02L-ECT	15	–	17
R88D-KN04L-ECT	22	17	13
R88D-KN01H-ECT	18	–	34
R88D-KN02H-ECT	18	–	34
R88D-KN04H-ECT	26	–	34
R88D-KN08H-ECT	46	12	25
R88D-KN10H-ECT	74	18	25
R88D-KN15H-ECT	74	18	25
R88D-KN20H-ECT	74	72	10
R88D-KN30H-ECT	113	60	7
R88D-KN50H-ECT	113	60	5
R88D-KN75H-ECT	282	–	4
R88D-KN150H-ECT	254	–	4
R88D-KN06F-ECT	64	21	100
R88D-KN10F-ECT	64	21	100
R88D-KN15F-ECT	64	21	100
R88D-KN20F-ECT	64	29	40
R88D-KN30F-ECT	106	60	40
R88D-KN50F-ECT	106	60	29
R88D-KN75F-ECT	273	–	14
R88D-KN150F-ECT	492	–	14

4-4-3 Regenerative Energy Absorption with an External Regeneration Resistor

If the regenerative energy exceeds the regeneration absorption capacity of the Servo Drive, connect an External Regeneration Resistor.

Connect the External Regeneration Resistor between B1 and B2 terminals on the Servo Drive.

Double-check the terminal names when connecting the resistor because the drive may be damaged if connected to the wrong terminals.

The surface of the External Regeneration Resistor will heat up to approx. 200°C. Do not place it near equipment and wiring that is easily affected by heat. Attach radiator plates suitable for the heat radiation conditions.

External Regeneration Resistor

● Characteristics

Model	Resistance value	Nominal capacity	The amount of regeneration absorption for 120°C temperature rise	Heat radiation condition	Thermal switch output specifications
R88A-RR08050S	50 Ω	80 W	20 W	Aluminum 350 × 350, Thickness: 3.0	Operating temperature: 150°C ± 5% NC contact Rated output (resistive load): 125 VAC, 0.1 A max. 30 VDC, 0.1 A max. (minimum current: 1 mA)
R88A-RR080100S	100 Ω	80 W	20 W	Aluminum 350 × 350, Thickness: 3.0	Operating temperature: 150°C ± 5% NC contact Rated output (resistive load): 125 VAC, 0.1 A max. 30 VDC, 0.1 A max. (minimum current: 1 mA)
R88A-RR22047S1	47 Ω	220 W	70 W	Aluminum 350 × 350, Thickness: 3.0	Operating temperature: 150°C ± 5% NC contact Rated output (resistive load): 250 VAC, 0.2 A max. 42 VDC, 0.2 A max. (minimum current: 1 mA)
R88A-RR50020S	20 Ω	500 W	180 W	Aluminum 600 × 600, Thickness: 3.0	Operating temperature 200°C ± 7°C NC contact Rated output: 250 VAC, 0.2 A max. 42 VDC, 0.2 A max. (minimum current: 1 mA)

4-4-4 Connecting an External Regeneration Resistor

R88D-KNA5L-ECT/-KN01L-ECT/-KN02L-ECT/-KN01H-ECT/ R88D-KN02H-ECT/-KN04H-ECT

Normally B2 and B3 are open.

If an External Regeneration Resistor is necessary, connect the External Regeneration Resistor between B1 and B2 as shown in the diagram below.

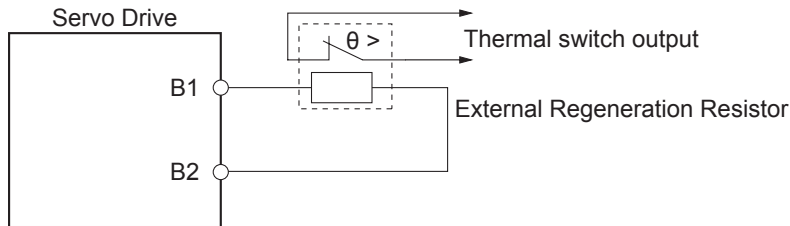

Precautions for Correct Use

- Connect the thermal switch output so that the main circuit power supply is shut OFF when the contacts open.
When using multiple External Regeneration Resistors, connect each thermal switch in series.
The resistor may be damaged by burning, or cause fire if it is used without setting up a power supply shutoff sequence using the output from the thermal switch.

R88D-KN04L-ECT/-KN08H-ECT/-KN10H-ECT/-KN15H-ECT/-KN20H-ECT/-KN30H-ECT/-KN50H-ECT/-KN06F-ECT/-KN10F-ECT/-KN15F-ECT/-KN20F-ECT/-KN30F-ECT/-KN50F-ECT

Normally B2 and B3 are shorted.

If an External Regeneration Resistor is necessary, remove the short-circuit bar between B2 and B3, and then connect the External Regeneration Resistor between B1 and B2 as shown in the diagram below.

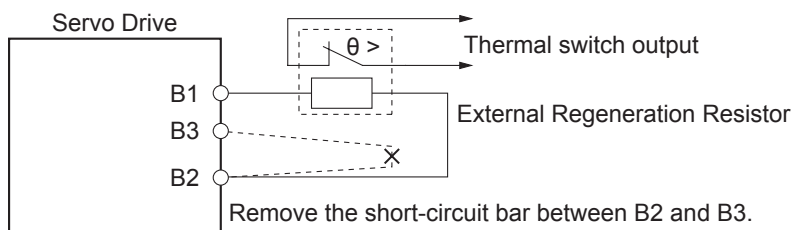

Precautions for Correct Use

- Connect the thermal switch output so that the main circuit power supply is shut OFF when the contacts open.
When using multiple External Regeneration Resistors, connect each thermal switch in series.
The resistor may be damaged by burning, or cause fire if it is used without setting up a power supply shutoff sequence using the output from the thermal switch.

R88D-KN75H-ECT/-KN150H-ECT/-KN75F-ECT/-KN150F-ECT

If an External Regeneration Resistor is necessary, connect the External Regeneration Resistor between B1 and B2 as shown in the diagram below.

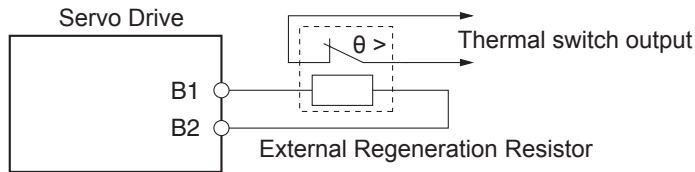

Precautions for Correct Use

- Connect the thermal switch output so that the main circuit power supply is shut OFF when the contacts open.
When using multiple External Regeneration Resistors, connect each thermal switch in series. The resistor may be damaged by burning, or cause fire if it is used without setting up a power shutoff sequence using the output from the thermal switch.

● Combining External Regeneration Resistors

Regeneration absorption capacity ^{*1}	20 W	40 W	70 W	140 W
Model	R88A-RR08050S R88A-RR080100S	R88A-RR08050S R88A-RR080100S	R88A-RR22047S1	R88A-RR22047S1
Resistance value ^{*2}	50 Ω/100 Ω	25 Ω/50 Ω	47 Ω	94 Ω
Connection method				

Regeneration absorption capacity ^{*1}	140 W	280 W	560 W
Model	R88A-RR22047S1	R88A-RR22047S1	R88A-RR22047S1
Resistance value ^{*2}	23.5 Ω	47 Ω	23.5 Ω
Connection method			

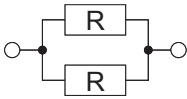
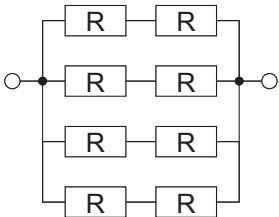
Regeneration absorption capacity ^{*1}	180 W	360 W	1440 W
Model	R88A-RR50020S	R88A-RR50020S	R88A-RR50020S
Resistance value ^{*2}	20 Ω	10 Ω	10 Ω
Connection method			

*1 Select a combination that has an absorption capacity greater than the average regeneration power (Pr).

*2 Do not use a combination with resistance values lower than the allowable minimum regeneration resistance of each drive. For information on the allowable minimum regeneration resistance, refer to 4-4-2 *Servo Drive Regeneration Absorption Capacity* on page 4-58.



Precautions for Safe Use

- Surface temperatures on regeneration resistance can reach 200°C. Do not place objects that tend to catch fire nearby. To prevent people from touching them, install a cover that enables heat dissipation.

4-5 Using DC Power Input

The following Servo Drive models allow you to use DC power input for the main circuit and control power supplies, in addition to AC power input.

- R88D-KN75H-ECT
- R88D-KN150H-ECT

No Servo Drive parameter change is necessary to switch from AC to DC power input, or vice versa.



Precautions for Correct Use

- To use DC power input for the main circuit and control power supplies, connect the positive wires to L1 and L1C and the negative wires to L3 and L3C of the terminal block (TB1).
 - Shutting off the main circuit power takes some time to discharge electricity. Beware of electrical shock because high voltage may remain in the Servo Drive after power shut OFF. Before carrying out wiring or inspection, turn OFF the main circuit power, and wait for at least 15 minutes.
 - Do not connect any power supply to B1 and N. Doing so may cause damage to internal elements.
 - Do not insert/remove the terminal block with the main circuit power supply ON. Doing so may cause an arc flash, resulting in burning.
-

4-5-1 Connection Example for Using DC power Input

R88D-KN75H-ECT (DC power input)

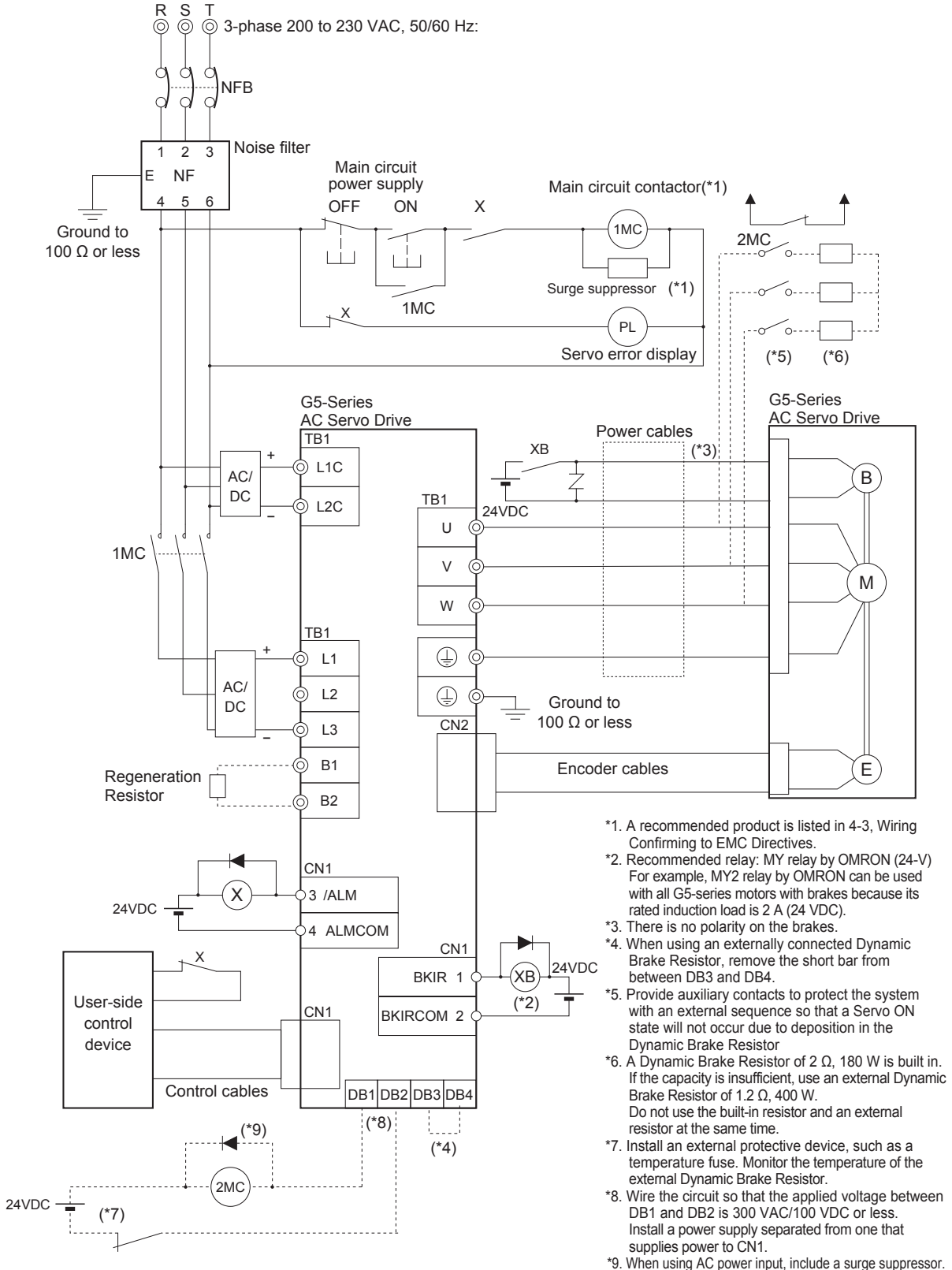

R88D-KN150H-ECT (DC power input)

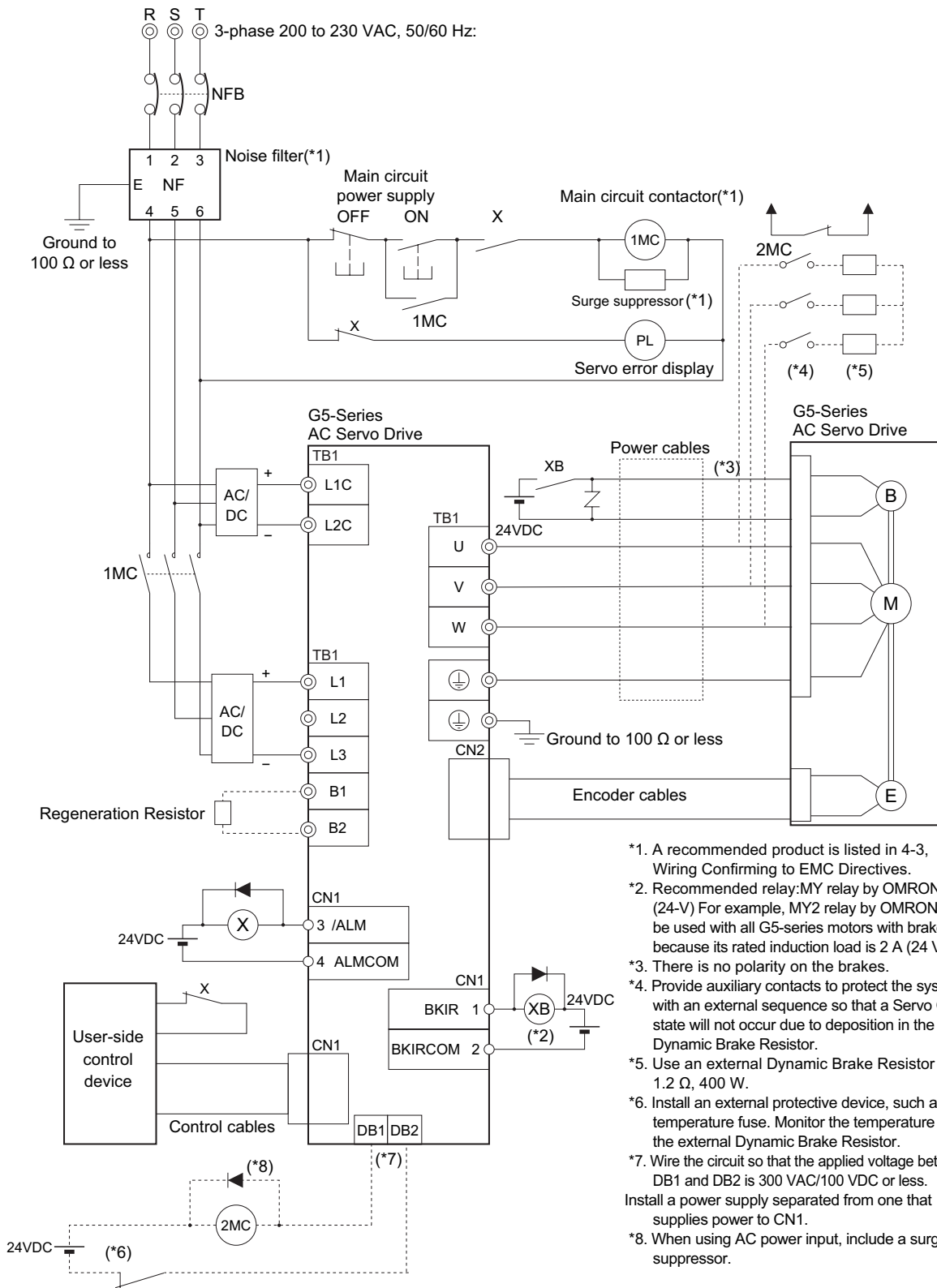

- *1. A recommended product is listed in 4-3, Wiring Confirming to EMC Directives.
- *2. Recommended relay: MY relay by OMRON (24-V) For example, MY2 relay by OMRON can be used with all G5-series motors with brakes because its rated induction load is 2 A (24 VDC).
- *3. There is no polarity on the brakes.
- *4. Provide auxiliary contacts to protect the system with an external sequence so that a Servo ON state will not occur due to deposition in the Dynamic Brake Resistor.
- *5. Use an external Dynamic Brake Resistor of 1.2 Ω, 400 W.
- *6. Install an external protective device, such as a temperature fuse. Monitor the temperature of the external Dynamic Brake Resistor.
- *7. Wire the circuit so that the applied voltage between DB1 and DB2 is 300 VAC/100 VDC or less. Install a power supply separated from one that supplies power to CN1.
- *8. When using AC power input, include a surge suppressor.

5

EtherCAT Communications

This chapter describes EtherCAT communications under the assumption that the G5-series Servo Drive is connected to an NJ501-1□-00 NJ-series Machine Automation Controller or CJ1W-NC281/NC481/NC881/NCF81/NC482/NC882 Position Control Unit.

5-1	Display Area and Settings	5-2
5-1-1	Node Address Setting	5-2
5-1-2	Status Indicators	5-3
5-2	Structure of the CAN Application Protocol over EtherCAT	5-4
5-3	EtherCAT State Machine	5-5
5-4	Process Data Objects (PDOs)	5-6
5-4-1	PDO Mapping Settings	5-6
5-4-2	Sync Manager PDO Assignment Settings	5-7
5-4-3	Fixed PDO Mapping	5-7
5-4-4	Variable PDO Mapping	5-9
5-4-5	Multiple PDO Mapping	5-10
5-5	Service Data Objects (SDOs)	5-12
5-5-1	Abort Codes	5-12
5-6	Synchronization with Distributed Clocks	5-13
5-6-1	Communications Cycle (DC Cycle)	5-13
5-7	Emergency Messages	5-14
5-8	Sysmac Device Features	5-15

5-1 Display Area and Settings

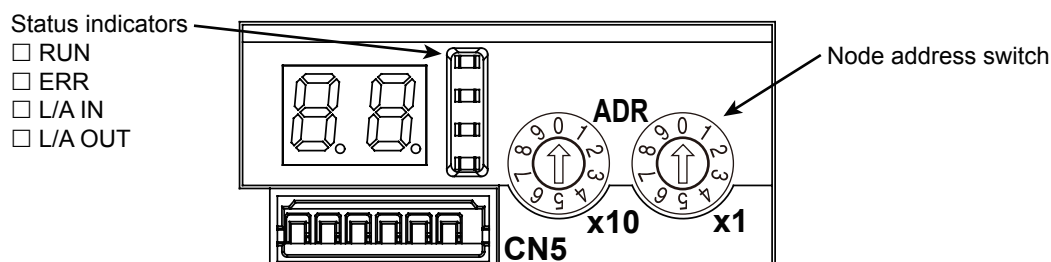

5-1-1 Node Address Setting

The node address switches located in the display area are used to set the EtherCAT node address.

Node address switch setting	Description
00	The controller sets the node address.
01 to 99	The node address switch setting is used as the node address.



Precautions for Correct Use

- Do not change the Node address switch setting after the turning ON the power supply.
- The node address switches can be set to between 00 and 99.
The node address used over the network is determined by the value set on the node address switches.
If the node address is not between 00 and 99, a Node Address Setting Error (Error No. 88.0) will occur.



Additional Information

EtherCAT Slave Information File

Information on EtherCAT slave settings is stored in the ESI (EtherCAT Slave Information) file.

Information in this file is used by the master to configure the network and set communications parameters. This information is in an XML file.

5-1-2 Status Indicators

The following table shows the EtherCAT status indicators and their meaning.

Name	Color	Status	Description
RUN	Green	OFF	Init state
		Blinking	Pre-Operational state
		Single flash	Safe-Operational state
		ON	Operational state
ERR	Red	OFF	No error
		Blinking	Communications setting error
		Single flash	Synchronization error or communications data error
		Double flash	Application WDT timeout
		Flickering	Boot error
		ON	PDI WDT timeout
L/A IN	Green	OFF	Link not established in physical layer
		ON	Link established in physical layer
		Flickering	In operation after establishing link
L/A OUT	Green	OFF	Link not established in physical layer
		ON	Link established in physical layer
		Flickering	In operation after establishing link

Indicator status is described below.

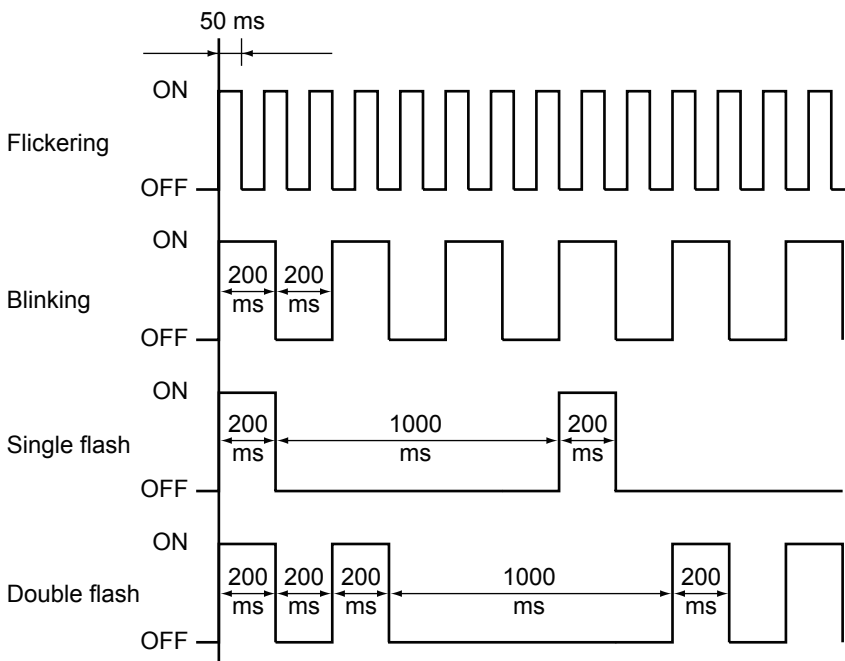

5-2 Structure of the CAN Application Protocol over EtherCAT

The structure of the CAN application protocol over EtherCAT (CoE) for a G5-series Servo Drive with built-in EtherCAT communications is described in this section.

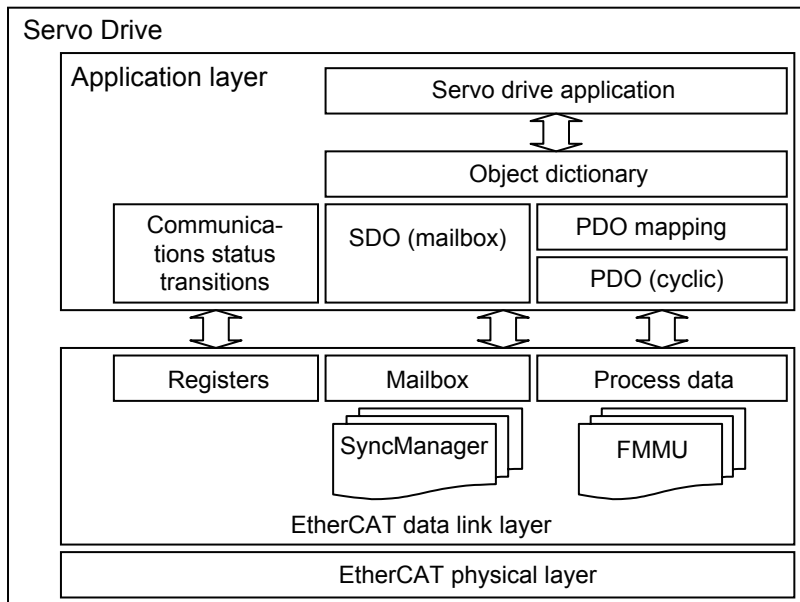

Normally, multiple protocols can be transmitted using EtherCAT. The IEC 61800-7 (CiA 402) drive profile is used for G5-series Servo Drives with Built-in EtherCAT Communications.

The object dictionary in the application layer contains parameters and application data as well as information on the PDO mapping between the process data servo interface and Servo Drive application.

The process data object (PDO) consists of objects in the object dictionary that can be mapped to the PDO. The contents of the process data are defined by the PDO mapping.

Process data communications cyclically reads and writes the PDO. Mailbox communications (SDO) uses asynchronous message communications where all objects in the object dictionary can be read and written.

5-3 EtherCAT State Machine

The EtherCAT State Machine (ESM) of the EtherCAT slave is controlled by the EtherCAT Master.

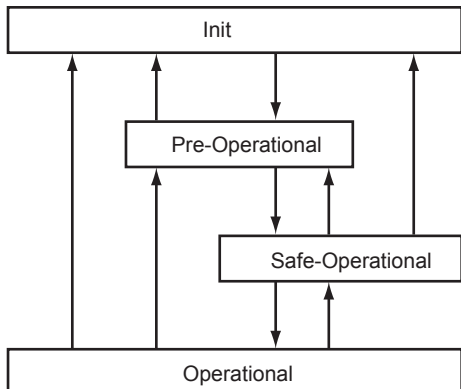

State	SDO communications	PDO reception	PDO transmission	Description
Init	Not possible.	Not possible.	Not possible.	Communications are being initialized. Communications are not possible.
Pre-Operational (Pre-Op)	Possible.	Not possible.	Not possible.	Only mailbox communications are possible in this state. This state is entered after initialization has been completed. It is used to initialize network settings.
Safe-Operational (Safe-Op)	Possible.	Not possible.	Possible.	In this state, PDO transmissions are possible in addition to mailbox communications. DC mode cyclic communications can be used to send information such as status from the Servo Drive.
Operational (Op)	Possible.	Possible.	Possible.	This is a normal operating state. DC mode cyclic communications can be used to control the motor.

5-4 Process Data Objects (PDOs)

The process data objects (PDOs) are used to transfer data during cyclic communications in realtime. PDOs can be reception PDOs (RxPDOs), which receive data from the controller, or transmission PDOs (TxPDOs), which send status from the Servo Drive to the host controller.

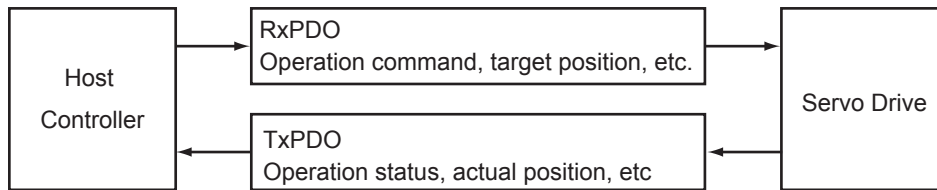

The EtherCAT application layer can hold multiple objects to enable transferring Servo Drive process data. The contents of the process data are described in the PDO Mapping object and the Sync manager PDO assignment object.

G5-series Servo Drives support PDO mapping for position control.

5-4-1 PDO Mapping Settings

The PDO mapping indicates the mapping for application objects (realtime process data) between the object dictionary and PDO.

The number of mapped objects is described in sub-index 00 hex of the mapping table. In this mapping table, 1600 hex to 17FF hex are for RxPDOs and 1A00 hex to 1BFF hex are for TxPDOs.

G5-series Servo Drives can use up to two mappings in 1600 hex and 1701 to 1705 hex for an RxPDO and in 1A00 hex, 1B01 to 1B04 hex, and 1BFF hex for a TxPDO, respectively.

The following table is an example of PDO mapping.

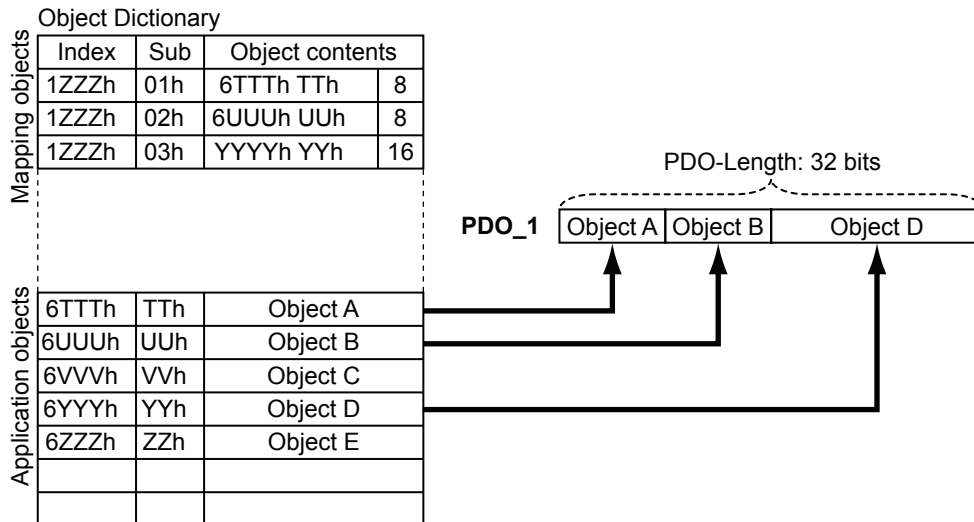

5-4-2 Sync Manager PDO Assignment Settings

A Sync manager channel consists of several PDOs. The Sync manager PDO assignment objects describe how these PDOs are related to the Sync Manager. The number of PDOs is given in sub-index 00 hex of the Sync manager PDO assignment table. In this table, index 1C12 hex is for RxPDOs and 1C13 hex is for TxPDOs.

The following table is an example of sync manager PDO mapping.

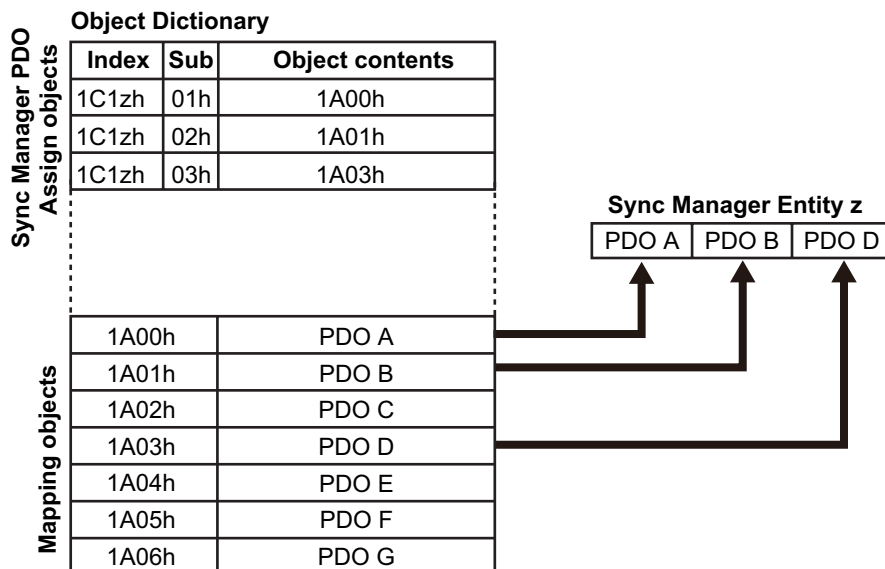

5-4-3 Fixed PDO Mapping

This section describes the contents of fixed PDO mapping for G5-series Servo Drives. This contents cannot be changed.

The PDO mapping to be used is specified in Sync Manager 2 PDO Assignment (1C12 hex) and Sync Manager 3 PDO Assignment (1C13 hex).

Some typical examples of RxPDO and TxPDO combinations are provided below.

PDO Mapping 1 (Position Control and Touch Probe Function)

This object gives the mapping for an application that uses only cyclic synchronous position mode (csp). Touch probe function is available.

RxPDO (1701h)	Controlword (6040 hex), Target position (607A hex), Touch probe function (60B8 hex), and Digital outputs (60FE hex)
TxPDO (1B01h)	Error code (603F hex), Statusword (6041 hex), Position actual value (6064 hex), Torque actual value (6077 hex), Following error actual value (60F4 hex), Touch probe status (60B9 hex), Touch probe pos1 pos value (60BA hex), Touch probe pos2 pos value (60BC hex), and Digital inputs (60FD hex)

PDO Mapping 2 (Position Control, Speed Control, Torque Control, and Touch Probe Function)

This is the mapping for an application that uses one of the following modes: Cyclic synchronous position mode (csp), Cyclic synchronous velocity mode, and Cyclic synchronous torque mode. Touch probe function is available.

RxPDO (1702h)	Controlword (6040 hex), Target position (607A hex), Target velocity (60FF hex), Target torque (6071 hex), Modes of operation (6060 hex), Touch probe function (60B8 hex), and Max profile velocity (607F hex)
TxPDO (1B02h)	Error code (603F hex), Statusword (6041 hex), Position actual value (6064 hex), Torque actual value (6077 hex), Modes of operation display (6061 hex), Touch probe status (60B9 hex), Touch probe pos1 pos value (60BA hex), Touch probe pos2 pos value (60BC hex), and Digital inputs (60FD hex)

PDO Mapping 3 (Position Control, Speed Control, Touch Probe Function, and Torque Limit)

This is the mapping for an application that switches between Cyclic synchronous position mode (csp) and Cyclic synchronous velocity mode. Touch probe function and torque limit can be used.

RxPDO (1703h)	Controlword (6040 hex), Target position (607A hex), Target velocity (60FF hex), Modes of operation (6060 hex), Touch probe function (60B8 hex), Positive torque limit value (60E0 hex), and Negative torque limit value (60E1 hex)
TxPDO (1B03h)	Error code (603F hex), Statusword (6041 hex), Position actual value (6064 hex), Torque actual value (6077 hex), Following error actual value (60F4 hex), Modes of operation display (6061 hex), Touch probe status (60B9 hex), Touch probe pos1 pos value (60BA hex), Touch probe pos2 pos value (60BC hex), and Digital inputs (60FD hex)

PDO Mapping 4 (Position Control, Speed Control, Torque Control, Touch Probe Function, and Torque Limit)

This is the mapping for an application that uses one of the following modes: Cyclic synchronous position mode (csp), Cyclic synchronous velocity mode, and Cyclic synchronous torque mode. Touch probe function and torque limit can be used.

RxPDO (1704h)	Controlword (6040 hex), Target position (607A hex), Target velocity (60FF hex), Target torque (6071 hex), Modes of operation (6060 hex), Touch probe function (60B8 hex), Max profile velocity (607F hex), Positive torque limit value (60E0 hex), and Negative torque limit value (60E1 hex)
TxPDO (1B02h)	Error code (603F hex), Statusword (6041 hex), Position actual value (6064 hex), Torque actual value (6077 hex), Modes of operation display (6061 hex), Touch probe status (60B9 hex), Touch probe pos1 pos value (60BA hex), Touch probe pos2 pos value (60BC hex), and Digital inputs (60FD hex)

PDO Mapping 5 (Position Control, Speed Control, Touch Probe Function, Torque Limit, and Torque Feed-forward)

This is the mapping for an application that switches between Cyclic synchronous position mode (csp) and Cyclic synchronous velocity mode. Touch probe function and torque limit can be used. The torque feed-forward amount can be specified by using the Torque offset (60B2 hex).

RxPDO (1705h)	Controlword (6040 hex), Target position (607A hex), Target velocity (60FF hex), Modes of operation (6060 hex), Touch probe function (60B8 hex), Positive torque limit value (60E0 hex), Negative torque limit value (60E1 hex), and Torque offset (60B2 hex)
TxPDO (1B04h)	Error code (603F hex), Statusword (6041 hex), Position actual value (6064 hex), Torque actual value (6077 hex), Modes of operation display (6061 hex), Touch probe status (60B9 hex), Touch probe pos1 pos value (60BA hex), Touch probe pos2 pos value(60BC hex), Digital inputs (60FD hex), and Velocity actual value (606C hex)

5-4-4 Variable PDO Mapping

G5-series Servo Drives with unit version 2.1 or later allow you to change the object mappings.

The PDO mappings for which you can change the mapped objects are the 1st receive PDO Mapping (1600 hex) and the 1st transmit PDO Mapping (1A00 hex).

To change the object mappings, set these values in Sync Manager 2 PDO Assignment (1C12 hex) and in Sync Manager 3 PDO Assignment (1C13 hex), respectively.

These object mappings can be changed only when the EtherCAT communications state is Pre-Operational (Pre-Op). Since the mappings you changed are not saved in EEPROM, you must specify objects each time you turn ON the power of the G5-series Servo Drive in order to use the mapping other than the default setting.

● Default Setting

RxPDO (1600 hex)	Controlword (6040 hex), Target position (607A hex), and Touch probe function (60B8 hex)
TxPDO (1A00 hex)	Error code (603F hex), Statusword (6041 hex), Position actual value (6064 hex), Touch probe status (60B9 hex), Touch probe pos1 pos value (60BA hex), Touch probe pos2 pos value (60BC hex), and Digital inputs (60FD hex)

● Maximum Number of Objects and Maximum Total Size Allowed in a PDO Mapping

PDO Mapping Object	Max. No. of Objects	Max. Total Size of Objects
RxPDO (1600 hex)	10	24 bytes
TxPDO (1A00 hex)	10	30 bytes

*1 When you assign the PDO mapping other than 1A00 hex simultaneously to TxPDO, total size must be 30 bytes or less. For example, if you assign 1BFF hex simultaneously, the total size of objects in 1A00 hex will be 29 bytes or less.



Precautions for Correct Use

- The communications cycle you can set varies depending on the total size of mapped objects. Refer to *A-1-3 Communications Cycles and Corresponding Modes of Operation* on page A-5 for details.
- If the size of the mapped objects exceeds the maximum total size, a Function Setting Error (Error No. 93.4) will occur.
- For information on the maximum number of objects allowed in a PDO Mapping, refer to *A-1-9 PDO Mapping Objects* on page A-31

5-4-5 Multiple PDO Mapping

G5-series Servo Drives with unit version 2.1 or later allow you to use combinations of up to two TxPDO mappings.

Select two PDO mappings in Sync manager 3 PDO assignment (1C13 hex).

This maps the object you selected with sub-index 01 (hex) at first and then the object you selected with sub-index 02 (hex).

If you map the same object more than once, the value of the last object will be enabled.

These object mappings can be changed only when the EtherCAT communications state is Pre-Operational (Pre-Op). Since the mappings you changed are not saved in EEPROM, you must specify objects each time you turn ON the power of the G5-series Servo Drive in order to use the mapping other than the default setting.

● Default Setting

Transmit PDO mapping (TxPDO)

- 1B01 hex

● Available PDO Mapping Combinations

Transmit PDO mapping (TxPDO) *1

- One of the mappings in 1B01 to 1B04 hex and another in 1BFF hex
- One mapping in 1A00 hex and another in 1BFF hex

*1 A maximum of 11 objects in total can be mapped to the Transmit PDO mapping.



Precautions for Correct Use

- The communications cycle you can set varies depending on the total size of mapped objects. Refer to *A-1-3 Communications Cycles and Corresponding Modes of Operation* on page A-5 for details.
- If the size of the mapped objects exceeds the maximum total size, a Function Setting Error (Error No. 93.4) will occur.
- If the number of the mapped objects exceeds the maximum allowed number, a Function Setting Error (Error No. 93.4) will occur.

5-5 Service Data Objects (SDOs)

G5-series Servo Drives support SDO communications. SDO communications are used for setting objects and monitoring the status of G5-series Servo Drives. Objects can be set and the status monitored by reading and writing data to the entries in the object dictionary of the host controller.

5-5-1 Abort Codes

The following table lists the abort codes for when an SDO communications error occurs.

Code	Meaning
0503 0000 hex	Toggle bit not changed
0504 0000 hex	SDO protocol timeout
0504 0001 hex	Client/Server command specifier not valid or unknown
0504 0005 hex	Out of memory
0601 0000 hex	Unsupported access to an object
0601 0001 hex	Attempt to read a write only object
0601 0002 hex	Attempt to write to a read only object
0602 0000 hex	The object does not exist in the object directory
0604 0041 hex	The object can not be mapped into the PDO.
0604 0042 hex	The number and length of the objects to be mapped would exceed the PDO length.
0604 0043 hex	General parameter incompatibility reason
0604 0047 hex	General internal incompatibility in the device.
0606 0000 hex	Access failed due to a hardware error.
0607 0010 hex	Data type does not match, length of service parameter does not match
0607 0012 hex	Data type does not match, length of service parameter too high
0607 0013 hex	Data type does not match, length of service parameter too low
0609 0011 hex	Subindex does not exist
0609 0030 hex	Value range of parameter exceeded (only for write access)
0609 0031 hex	Value of parameter written too high
0609 0032 hex	Value of parameter written too low
0609 0036 hex	Maximum value is less than minimum value
0800 0000 hex	General error
0800 0020 hex	Data cannot be transferred or stored to the application
0800 0021 hex	Data cannot be transferred or stored to the application because of local control ^{*1}
0800 0022 hex	Data cannot be transferred or stored to the application because of the present device state
0800 0023 hex	Object dictionary dynamic generation fails or no object dictionary is present

*1 In this status, the slave is operating locally and cannot be controlled from the EtherCAT master.

5-6 Synchronization with Distributed Clocks

A mechanism called a distributed clock (DC) is used to synchronize EtherCAT communications. The DC mode is used for G5-series Servo Drives to perform highly accurate control in a multi-axis system.

In DC mode, the master and slaves are synchronized by sharing the same clock.

Interruptions (Sync0) are generated in the slaves at precise intervals based on this clock.

Servo Drive control is carried out at this precise timing.

5-6-1 Communications Cycle (DC Cycle)

The communications cycle is determined by setting the Sync0 signal output cycle.

Setting range: 250 μ s/500 μ s/1 ms/2 ms/4 ms



Precautions for Correct Use

The communications cycle you can set varies depending on conditions such as the Servo Drive unit version or the modes of operation in use. For details on the communications cycle you can set, refer to *A-1-3 Communications Cycles and Corresponding Modes of Operation* on page A-5

5-7 Emergency Messages

When an error or warning occurs in a G5-series Servo Drive, an emergency message is sent to the master using mailbox communications. An emergency message is not sent for a communications error.

You can select whether to send emergency messages setting Diagnosis History (10F3 hex).

When the power supply is turned ON, this setting is set not to send emergency message (10F3 hex, Sub: 05 hex (Flags) = 0).

Set the sub-index 05 hex (Flags) in object 10F3 hex to 1 every time the power is turned ON to send emergency messages.

Emergency messages consist of 8 bytes of data.

Byte	0	1	2	3	4	5	6	7
Contents	Emergency Error Code ^{*1}		Error Register (1001 hex)	Manufacturer Specific Error Field ^{*2}				

*1 Error codes (FF00 hex to FFFF hex) in the manufacturer-specific area are used.

*2 For unit version 2.0, the third to seventh bytes are not used.

For unit version 2.1, the third byte is not used, with an error event code shown in the fourth to seventh bytes.

For details on error event codes, refer to *A-3 Sysmac Error Status Codes* on page A-94.

Note For details on errors and warnings of the Servo Drive, refer to *Chapter 12 Troubleshooting and Maintenance*.

5-8 Sysmac Device Features

The control device product designed according to standardized communications and user interface specifications for OMRON control devices are called a Sysmac Device.

And the features available with such a Device is called Sysmac Device Features.

This section describes the features the G5-series Servo Drive provides when combined with a Machine Automation Controller such as NJ series and automation software.

For G5-series Servo Drives with built-in EtherCAT communications, those Servo Drives with unit version 2.1 or later are Sysmac Devices.

● Sysmac Error Status

Because, in Sysmac Devices, errors that may occur in slaves are systematized, you can check the causes and remedies for errors with a common procedure.

The status of an error can be monitored in the Sysmac Error Status (2002-01 hex). To display the error status detected by the G5-series Servo Drive in Sysmac Studio, the Sysmac Error Status (2002-01 hex) must be mapped to the PDO. Sysmac Studio, by default, uses the 512th transmit PDO Mapping assignment to map the Sysmac Error Status (2002-01 hex) automatically to the PDO.



Additional Information

- For the Sysmac Error status (2002-01 hex), refer to *A-1-11 Manufacturer Specific Objects* on page A-49.
- For errors displayed in Sysmac Studio, refer to *A-3 Sysmac Error Status Codes* on page A-94.

● Saving the Node Address Setting

When the node address switch setting is “00” (Software Setup mode), the node address value you set in Sysmac Studio is enabled.

In the Software Setup mode, in Sysmac Studio, execute [Write Slave Node Address] on the [EtherCAT Edit] screen to save the slave node address setting in the nonvolatile memory of the G5-series Servo Drive.

• Software Setting

The set value saved as Slave Information Interface (SII) information in the nonvolatile memory of the slave is the node address.

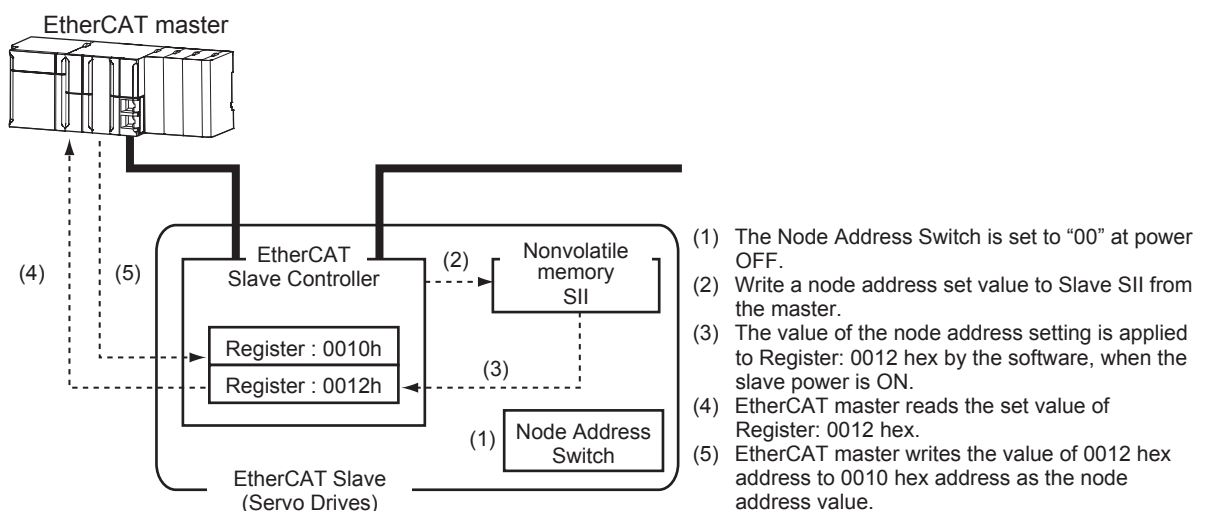

- Node Address Switch Setting

The value set on the node address switches is the node address.

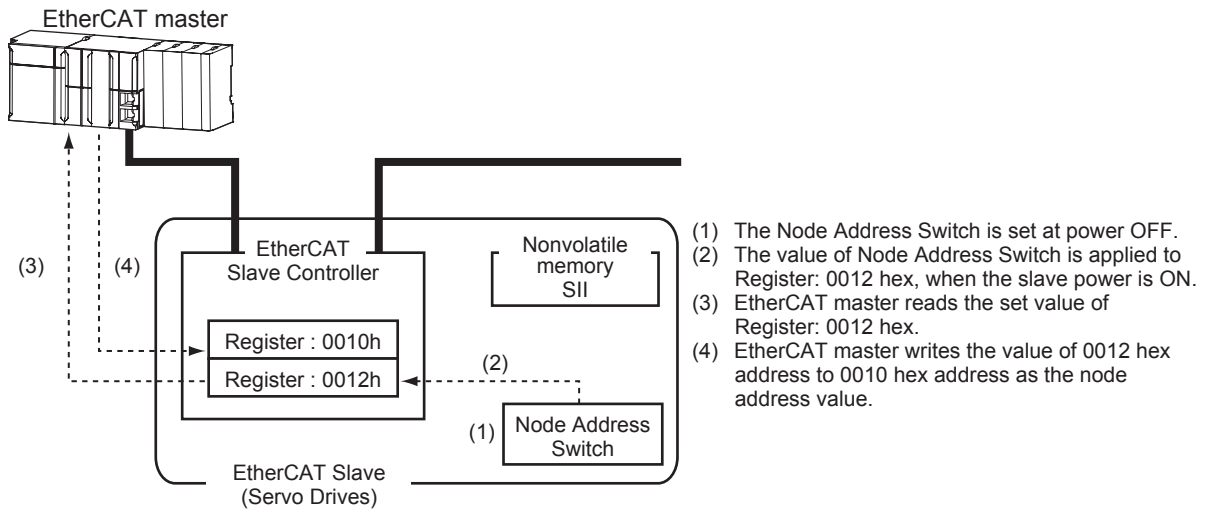

- Serial Number Display

The serial number saved in the nonvolatile memory of the G5-series Servo Drive is displayed in the Serial Number (1018-04 hex). Controllers that support Sysmac Device Features can use this serial number to check the network configuration.

To enable this check, in Sysmac Studio, set [Serial No. Check Condition] to [Set Value = Actual Unit] on the [EtherCAT Edit] screen.

If the set condition is not met, a Network Configuration Check Error will occur.



Additional Information

This network configuration check detects any slave devices that have been replaced, which prevents you from forgetting to set parameters on those slaves.

- Compliance with ESI Specification (ETG.2000 S (R) V1.0.1)

The ESI Specification is a set of specifications that define the entries required in an EtherCAT Slave Information (ESI) file.

Controllers that support Sysmac Device Features can use the Option function defined in the ESI Specification to identify the backup parameters stored on slaves.

The backup parameters on an identified slave can be backed up and restored from Sysmac Studio.

For the parameters backed up with the G5-series Servo Drive, refer to *Store Parameters* on page A-26.

● SII Data Check

The Slave Information Interface (SII) is an interface area in the nonvolatile memory of an EtherCAT slave that stores the configuration information specific to that EtherCAT slave.

Sysmac Device EtherCAT slaves check the SII information from the slave side.

If one of these slaves finds that SII information with which it cannot operate was written, it generates an SII Check Error (Error No. 88.3). If this error persists even after turning OFF and then ON the power again, contact your OMRON sales representative.



Precautions for Correct Use

Do not use third-party or any other configuration tools to edit the SII information.

6

Basic Control Functions

This chapter explains an outline of basic control functions and explains the contents of setting.

6-1	Cyclic Synchronous Position Mode	6-2
6-1-1	Related Objects	6-3
6-1-2	Block Diagram for Position Control Mode	6-4
6-2	Cyclic Synchronous Velocity Mode	6-5
6-2-1	Related Objects	6-6
6-2-2	Objects Requiring Settings	6-6
6-2-3	Related Functions	6-6
6-2-4	Block Diagram for Speed Control Mode	6-7
6-3	Cyclic Synchronous Torque Mode	6-8
6-3-1	Related Objects	6-9
6-3-2	Objects Requiring Settings	6-9
6-3-3	Related Functions	6-9
6-3-4	Block Diagram for Torque Control Mode	6-10
6-4	Profile Position Mode	6-11
6-4-1	Related Objects	6-12
6-4-2	Description of Function	6-13
6-4-3	Controlword (6040 hex) in Profile Position Mode	6-14
6-4-4	Statusword (6041 hex) in Profile Position Mode	6-14
6-5	Homing Mode	6-15
6-6	Fully-closed Control	6-16
6-6-1	Outline of Operation	6-16
6-6-2	Objects Requiring Settings	6-17
6-6-3	Block Diagram for Fully-closed Control Mode	6-22
6-7	Connecting with OMRON Controllers	6-23

6-1 Cyclic Synchronous Position Mode

In this mode of operation, the controller has a path generation function (an operation profile calculation function) and it gives the target position to the Servo Drive using cyclic synchronization. Position control, speed control, and torque control are performed by the Servo Drive.

The Velocity offset (60B1 hex) and Torque offset (60B2 hex) can be used as speed feed-forward and torque feed-forward amounts.

Cyclic Synchronous Position Mode Configuration

The following diagram shows the configuration of the Cyclic synchronous position mode.

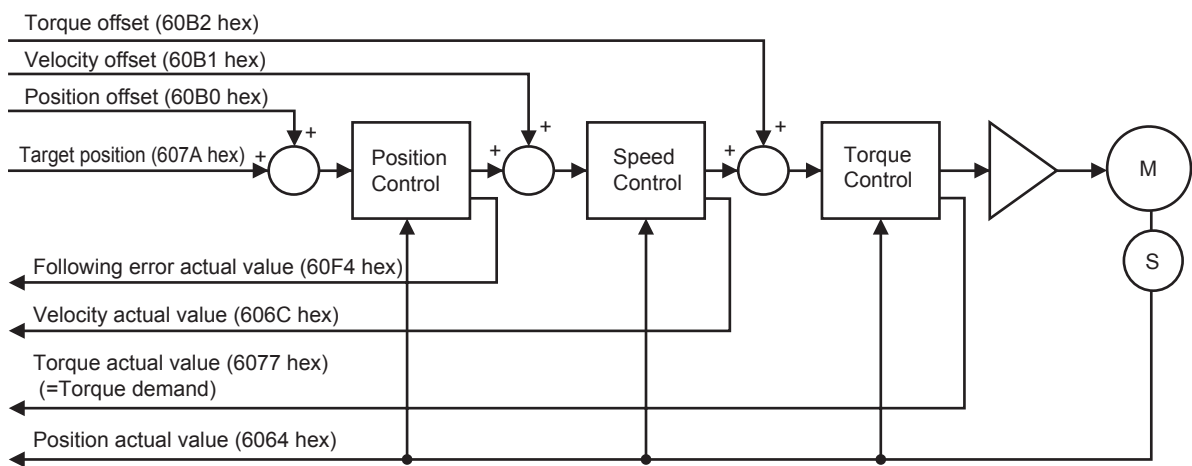

The following diagram shows the configuration of the control function of the Cyclic synchronous position mode.

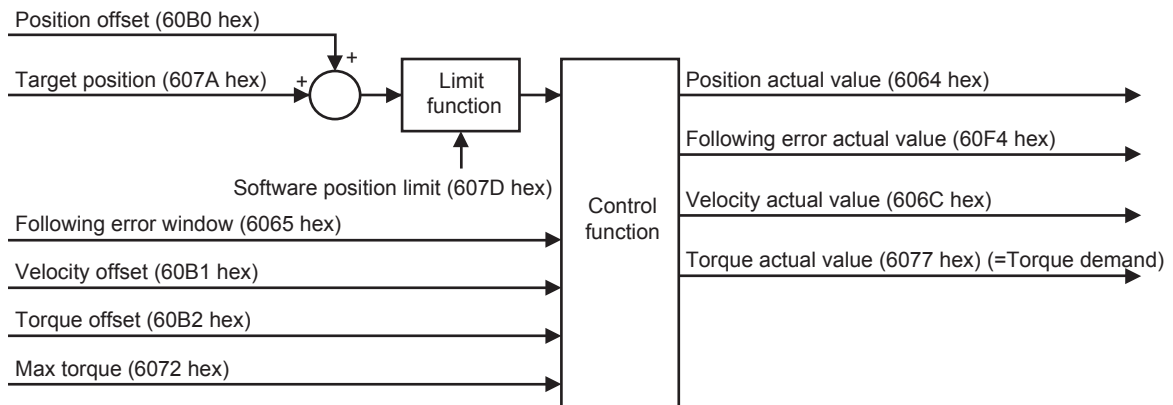

6-1-1 Related Objects

Index	Sub-index	Name	Access	Size	Unit	Setting range	Default setting
6040 hex	00 hex	Controlword	RW	U16	0 to FFFF hex	–	0000 hex
6060 hex	00 hex	Modes of operation	RW	INT8	–	0 to 10	0
607A hex	00 hex	Target position	RW	INT32	Command units	–2,147,483,648 to 2,147,483,647	0000 hex
6065 hex ^{*1}	00 hex	Following error window	RW	U32	Command units	0 to 134,217,728, or 4,294,967,295	100000
6072 hex	00 hex	Max torque	RW	U16	0.1%	0 to 5,000	5000
60B0 hex	00 hex	Position offset	RW	INT32	Command units	–2,147,483,648 to 2,147,483,647	0000 hex
60B1 hex	00 hex	Velocity offset	RW	INT32	Command units/s	–2,147,483,648 to 2,147,483,647	0000 hex
60B2 hex	00 hex	Torque offset	RW	INT16	0.1%	–5,000 to 5,000	0
6041 hex	00 hex	Statusword	RO	U16	0 to FFFF hex	–	0000 hex
6064 hex	00 hex	Position actual value	RO	INT32	Command units	–2,147,483,648 to 2,147,483,647	0000 hex
606C hex	00 hex	Velocity actual value	RO	INT32	Command units/s	–2,147,483,647 to 2,147,483,647	0000 hex
6077 hex	00 hex	Torque actual value	RO	INT16	0.1%	–5,000 to 5,000	0000 hex
60F4 hex	00 hex	Following error actual value	RO	INT32	Command units	–2,147,483,648 to 2,147,483,647	0000 hex

*1 The Following error window object can be set to between 0 and 134,217,728, or 4,294,967,295. If the object is set to 4,294,967,295, the detection of Following error will be disabled. If it is set to 0, a Following error will always occur. If the set value is between 134,217,729 and 4,294,967,294, it is set to 134,217,728. In this case, 134,217,728 will be returned when the object is read.

6-1-2 Block Diagram for Position Control Mode

The following block diagram is for position control using an R88D-KN□□□-ECT-series Servo Drive.

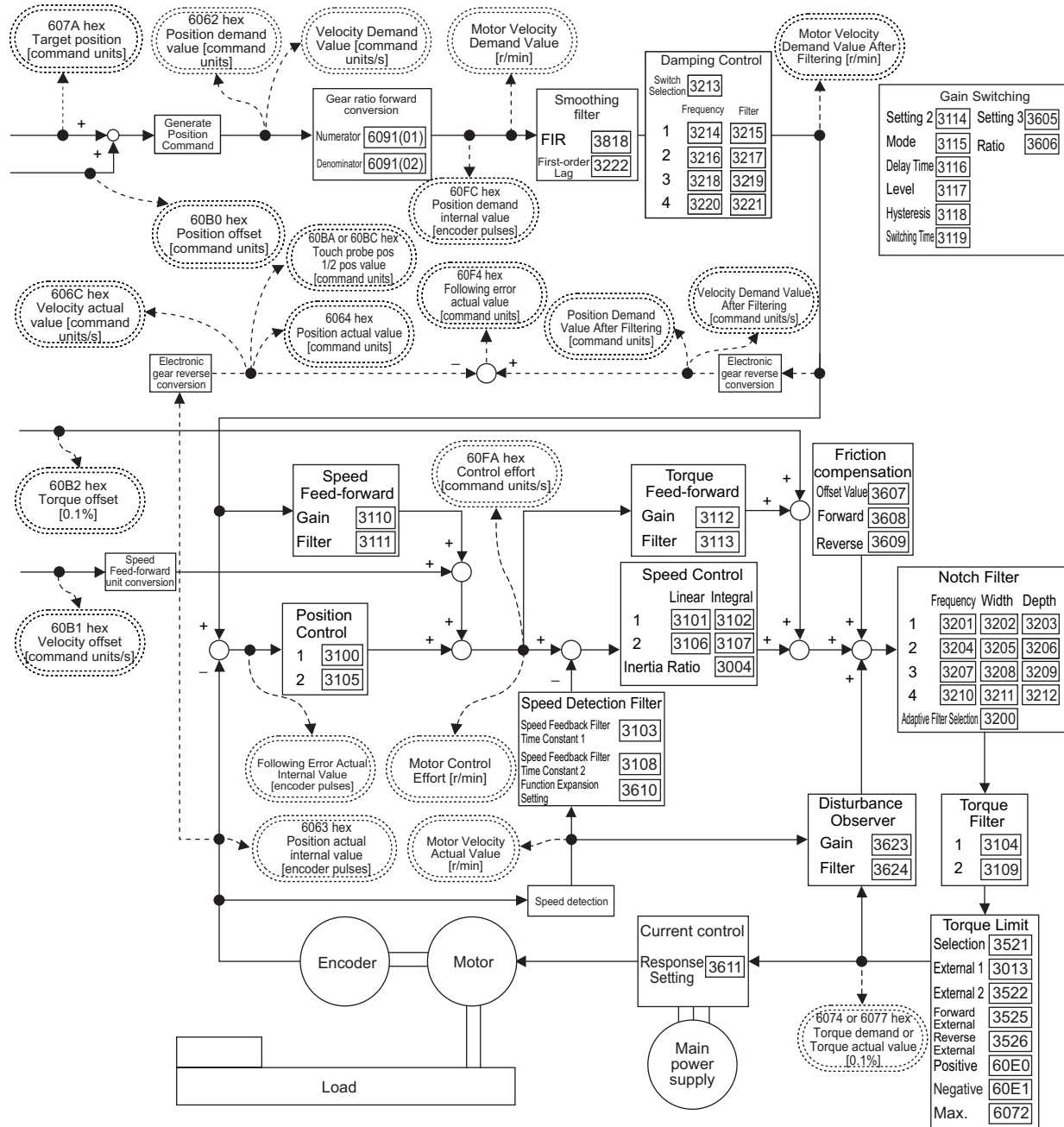

- Note 1** Numbers within parentheses are sub-index numbers.
Note 2 Numbers within boxes are hexadecimal index numbers.
Note 3 Profile position mode (pp) and Homing mode (hm) are also included in this block diagram.
Note 4 Profile position mode (pp) is supported for unit version 2.1 or later.
Note 5 The electronic gear function is not supported for unit version 2.0. For the Servo Drives with unit version 2.0, set the electronic gear ratio to 1.1.

6-2 Cyclic Synchronous Velocity Mode

In this mode of operation, the controller has a path generation function (an operation profile calculation function) and it gives the target speed to the Servo Drive using cyclic synchronization. Speed control and torque control are performed by the Servo Drive.

The Torque offset (60B2 hex) can be used as the torque feed-forward amount.

Cyclic Synchronous Velocity Mode Configuration

The following diagram shows the configuration of the Cyclic synchronous velocity mode.

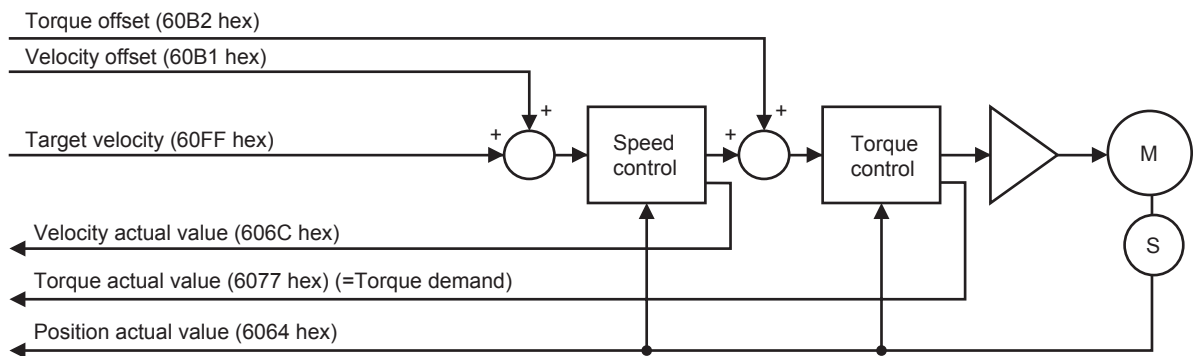

The following diagram shows the control function configuration of the Cyclic synchronous velocity mode.

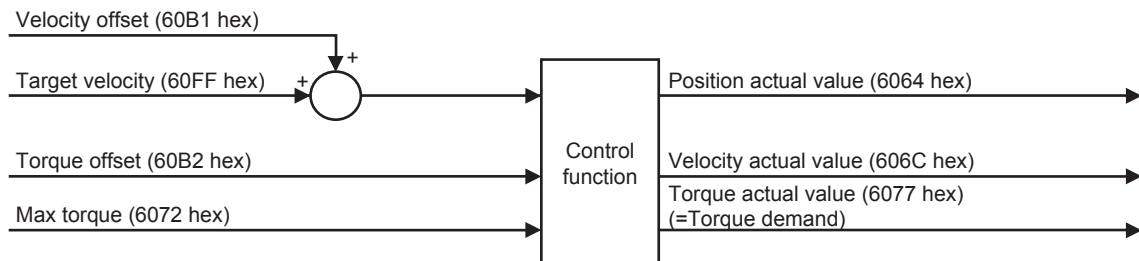

6-2-1 Related Objects

Index	Sub-index	Name	Access	Size	Unit	Setting range	Default setting
6040 hex	00 hex	Controlword	RW	U16	0 to FFFF hex	–	0000 hex
6060 hex	00 hex	Modes of operation	RW	INT8	–	0 to 10	0
60FF hex	00 hex	Target velocity	RW	INT32	Command units/s	–2,147,483,647 to 2,147,483,647	0000 hex
6072 hex	00 hex	Max torque	RW	U16	0.1%	0 to 5,000	5000
60B1 hex	00 hex	Velocity offset	RW	INT32	Command units/s	–2,147,483,648 to 2,147,483,647	0000 hex
60B2 hex	00 hex	Torque offset	RW	INT16	0.1%	–5,000 to 5,000	0
6041 hex	00 hex	Statusword	RO	U16	0 to FFFF hex	–	0000 hex
6064 hex	00 hex	Position actual value	RO	INT32	Command units	–2,147,483,648 to 2,147,483,647	0000 hex
606C hex	00 hex	Velocity actual value	RO	INT32	Command units/s	–2,147,483,647 to 2,147,483,647	0000 hex
6077 hex	00 hex	Torque actual value	RO	INT16	0.1%	–5,000 to 5,000	0000 hex

6-2-2 Objects Requiring Settings

Index	Name	Description	Reference
3312 hex	Soft Start Acceleration Time	Set the acceleration time for internally set speed control. Set the time until 1,000 r/min is reached.	page 9-26
3313 hex	Soft Start Deceleration Time	Set the deceleration time for internally set speed control. Set the time until 1,000 r/min is reached.	page 9-26
3314 hex	S-curve Acceleration/Deceleration Time Setting	Set the S-curve time in the time width centered on the inflection points for acceleration and deceleration.	page 9-27

6-2-3 Related Functions

Index	Name	Description	Reference
3435 hex	Speed Conformity Detection Range	Set the detection threshold for speed conformity output. If the difference between the speed command and motor speed is within the set threshold, a speed conformity output is output. This setting has a hysteresis of 10 r/min for detection.	page 9-37
3436 hex	Rotation Speed for Motor Rotation Detection	Set the detection threshold for motor rotation detection output. A motor rotation detection output will be output when the motor speed has exceeded the set value.	page 9-37

6-2-4 Block Diagram for Speed Control Mode

The following block diagram is for speed control using an R88D-KN□□□-ECT-series Servo Drive.

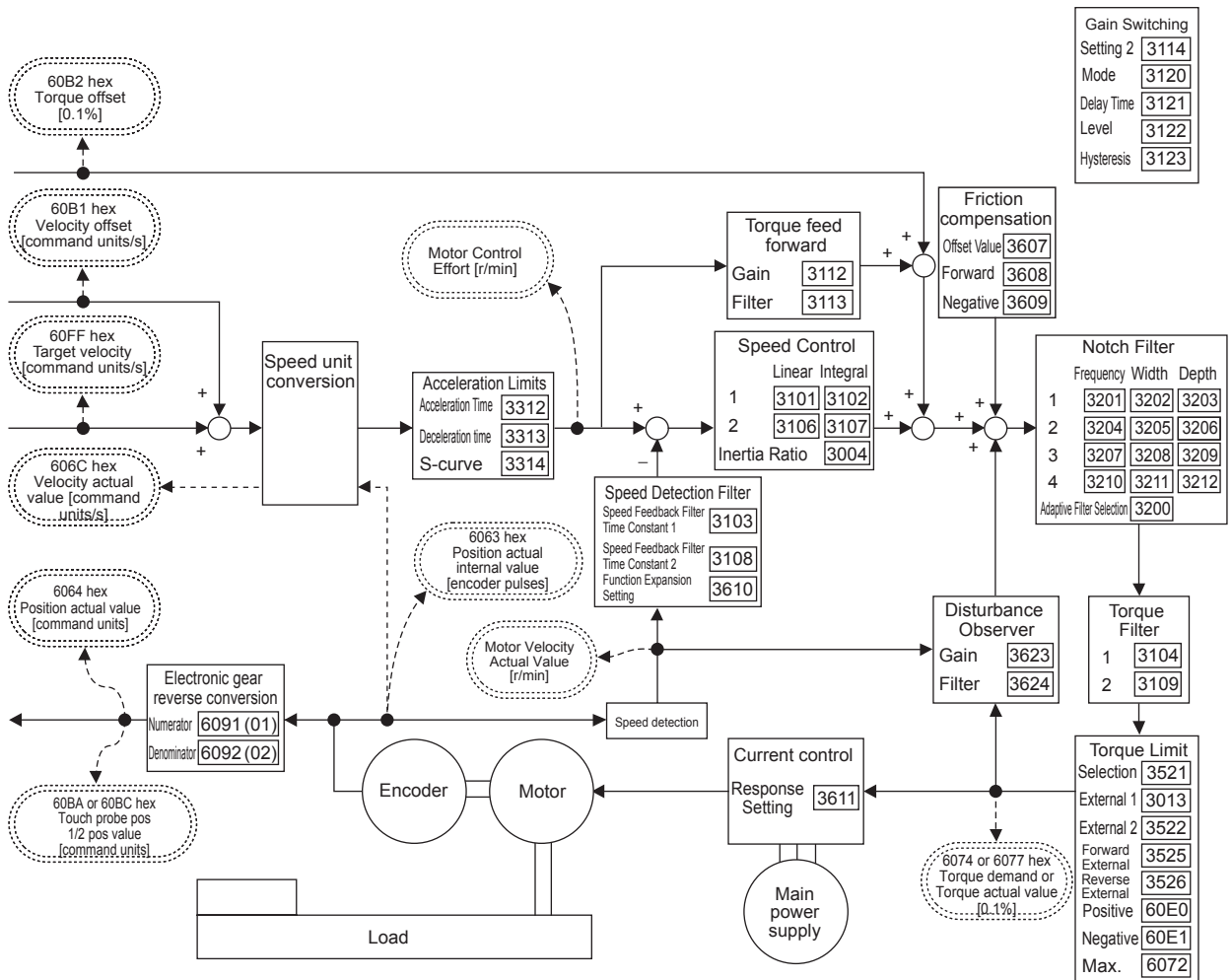

- Note 1** Numbers within parentheses are sub-index numbers.
2 Numbers within boxes are hexadecimal index numbers.
3 The electronic gear function is not supported for unit version 2.0. For the Servo Drives with unit version 2.0, set the electronic gear ratio to 1.1.

6-3 Cyclic Synchronous Torque Mode

In this mode of operation, the controller has a path generation function (an operation profile calculation function) and it gives the target torque to the Servo Drive using cyclic synchronization. Torque control is performed by the Servo Drive.

Cyclic Synchronous Torque Mode Configuration

The following diagram shows the configuration of the Cyclic synchronous torque mode.

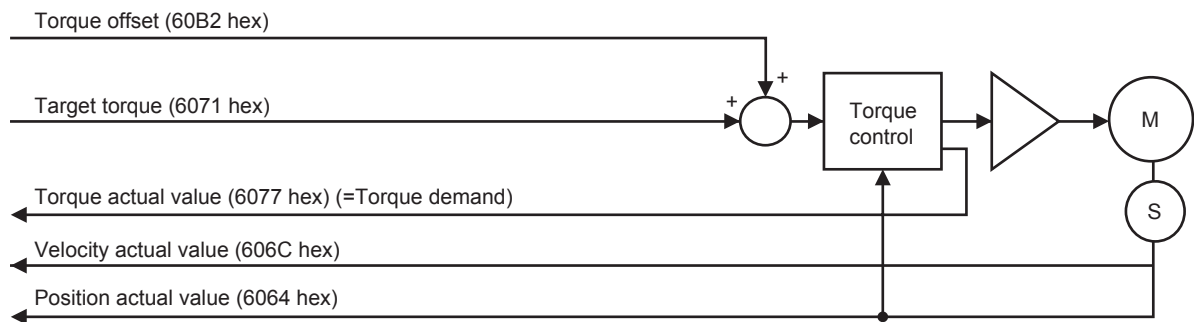

The following diagram shows the configuration of the Cyclic synchronous torque mode.

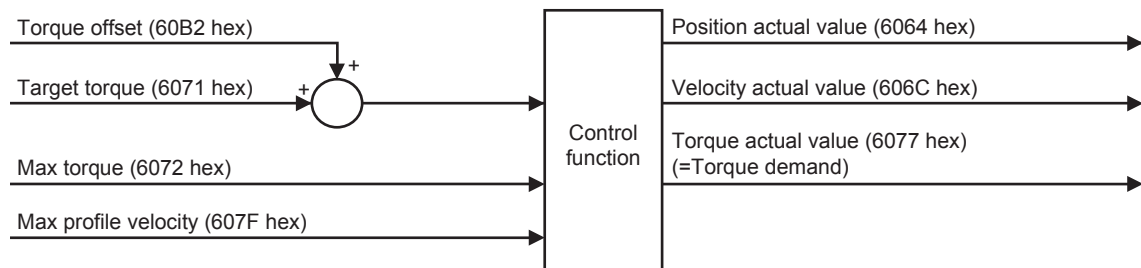

6-3-1 Related Objects

Index	Sub-index	Name	Access	Size	Unit	Setting range	Default setting
6040 hex	00 hex	Controlword	RW	U16	0 to FFFF hex	–	0000 hex
6060 hex	00 hex	Modes of operation	RW	INT8	–	0 to 10	0
6071 hex	00 hex	Target torque	RW	INT16	0.1%	–5,000 to 5,000	0000 hex
6072 hex	00 hex	Max torque	RW	U16	0.1%	0 to 5,000	5000
607F hex	00 hex	Max profile velocity	RW	U32	Command units/s	0 to 2,147,483,647	0000 hex
60B2 hex	00 hex	Torque offset	RW	INT16	0.1%	–5,000 to 5,000	0
6041 hex	00 hex	Statusword	RO	U16	0 to FFFF hex	–	0000 hex
6064 hex	00 hex	Position actual value	RO	INT32	Command units	–2,147,483,648 to 2,147,483,647	0000 hex
606C hex	00 hex	Velocity actual value	RO	INT32	Command units/s	–2,147,483,647 to 2,147,483,647	0000 hex
6077 hex	00 hex	Torque actual value	RO	INT16	0.1%	–5,000 to 5,000	0000 hex

6-3-2 Objects Requiring Settings

Index	Name	Description	Reference
3317 hex	Speed Limit Selection	Select the input location for the speed limit.	page 9-27

Speed Limit Selection (3317 hex)

Restricts the speed as the protection during torque control.

Controls that the speed does not exceed the Speed Limit during torque control.

Index	Name	Description	Setting range	Unit
3317 hex	Speed Limit Selection	Selects the input type of the Speed Limit during torque control. 0: Control the speed by the Speed Limit Value Setting (3321 hex). 1: Control the speed by either one of the smaller value: the Speed Limit Value (607F) by EtherCAT communications, or the Speed Limit Value Setting (3321 hex)	0 to 1	–

6-3-3 Related Functions

Index	Name	Description	Reference
3321 hex	Speed Limit Value Setting	Set the speed limit value applicable during torque control. During torque control, the speed is controlled so as not to exceed the level set by the speed limit value.	page 9-27

6-3-4 Block Diagram for Torque Control Mode

The following block diagram is for torque control using an R88D-KN□□□-ECT-series Servo Drive.

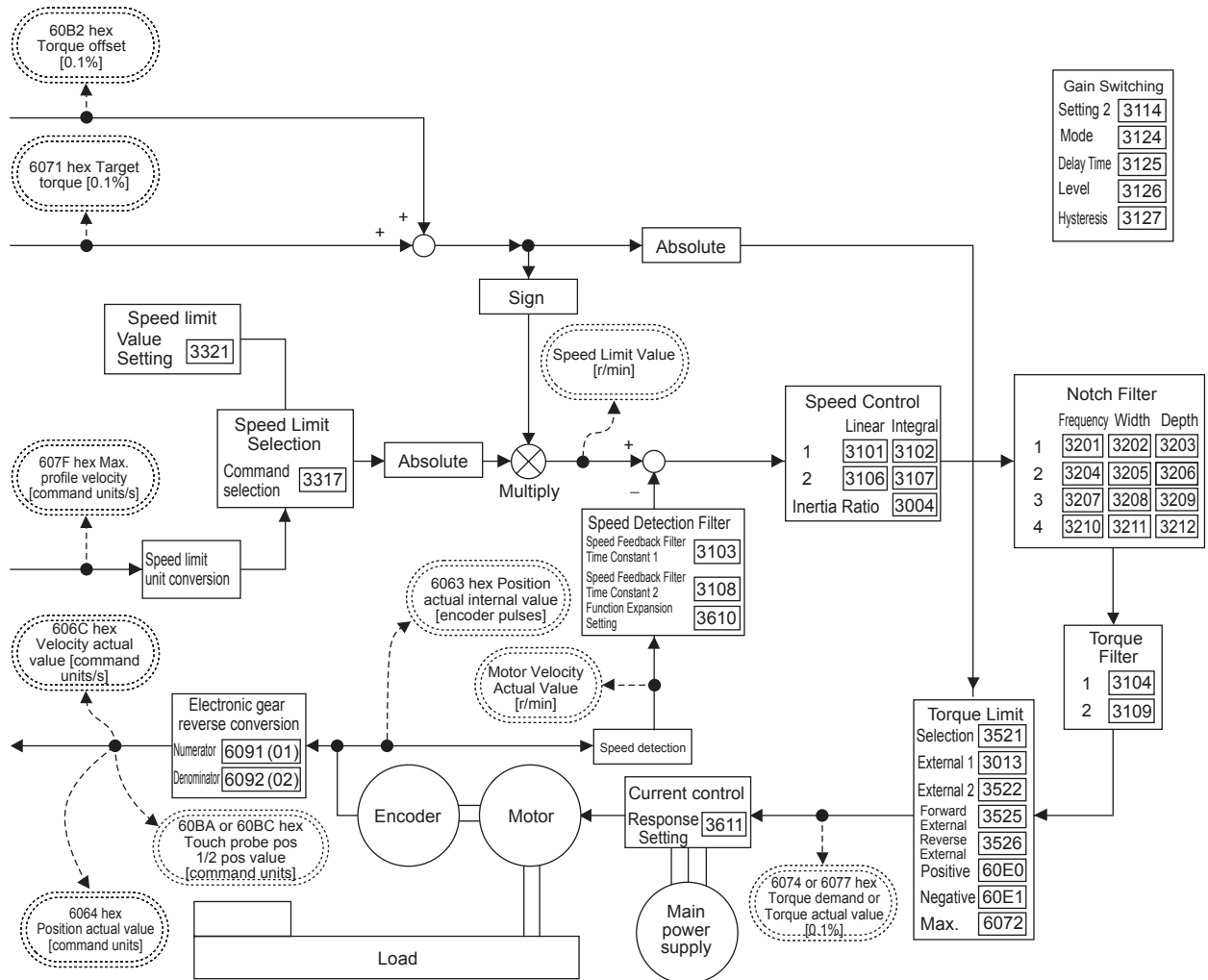

- Note 1** Numbers within parentheses are sub-index numbers.
Note 2 Numbers within boxes are hexadecimal index numbers.
Note 3 The electronic gear function is not supported for unit version 2.0. For the Servo Drives with unit version 2.0, set the electronic gear ratio to 1.1.

6-4 Profile Position Mode

In this mode of operation, the controller uses the path generation function (an operation profile calculation function) inside the G5-series Servo Drive to perform PTP positioning operation. It executes path generation, position control, speed control, and torque control based on the target position, profile velocity, profile acceleration, profile deceleration, and other information.



Precautions for Correct Use

Profile position mode is supported for unit version 2.1 or later.

For functional differences between unit versions, refer to *A-5 Functional Differences among Unit Versions* on page A-169.

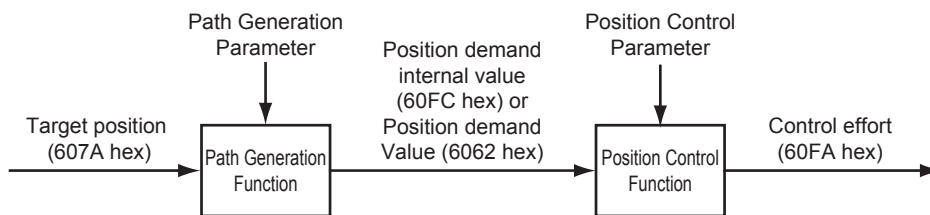

The configuration of the path generation function is as follows:

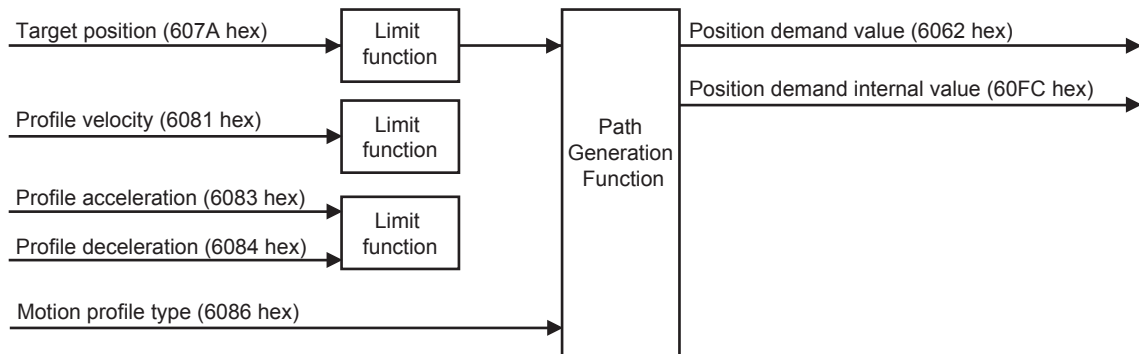

Profile Position Mode Configuration

The configuration of Profile position mode is as follows:

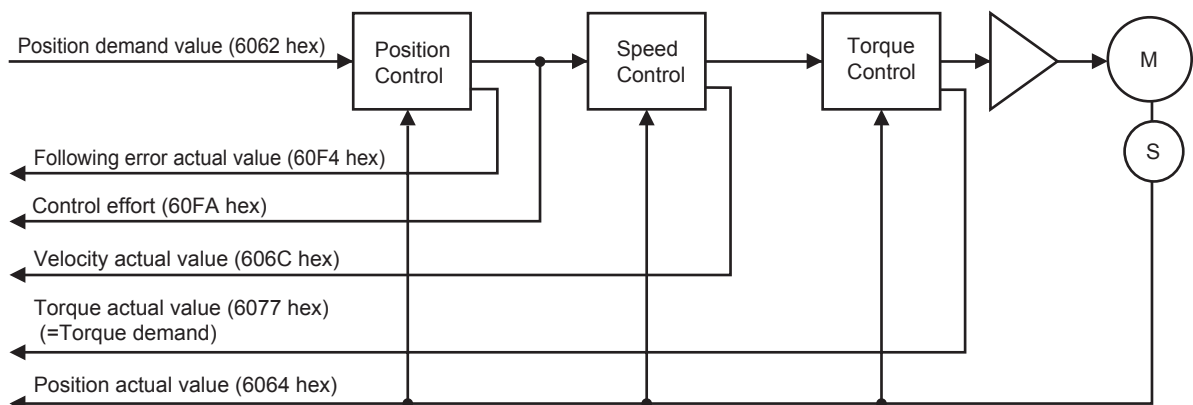

The following diagram shows the control function configuration of Profile position mode.

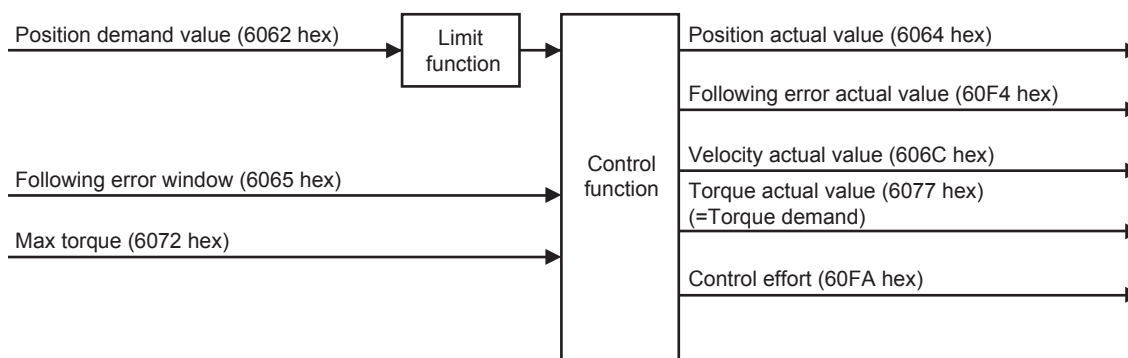

6-4-1 Related Objects

Index	Sub-index	Name	Access	Size	Unit	Setting range	Default setting
6040 hex	00 hex	Controlword	RW	U16	–	0 to FFFF hex	0000 hex
6060 hex	00 hex	Modes of operation	RW	INT8	–	0 to 10	0
6065 hex ^{*1}	00 hex	Following error window	RW	U32	Command units	0 to 134,217,728, or 4,294,967,295	100000
6072 hex	00 hex	Max torque	RW	U16	0.1%	0 to 5000	5000
607A hex ^{*2}	00 hex	Target position	RW	INT32	Command units	–2,147,483,648 to 2,147,483,647	0000 hex
607D hex	01 hex	Min position limit	RW	INT32	Command units	–1,073,741,823 to 1,073,741,823	–500000
	02 hex	Max position limit	RW	INT32	Command units	–1,073,741,823 to 1,073,741,823	500000
6081 hex	00 hex	Profile velocity	RW	U32	Command units/s	0 to 2,147,483,647	0000 hex
6083 hex	00 hex	Profile acceleration	RW	U32	Command units/s ²	1 to 655,350,000	1000000
6084 hex	00 hex	Profile deceleration	RW	U32	Command units/s ²	1 to 655,350,000	1000000
6086 hex	00 hex	Motion profile type	RW	INT16	–	–1 to 0	0
6041 hex	00 hex	Statusword	RO	U16	–	0 to FFFF hex	0000 hex
6062 hex	00 hex	Position demand value	RO	INT32	Command units	–2,147,483,648 to 2,147,483,647	0
6064 hex	00 hex	Position actual value	RO	INT32	Command units	–2,147,483,648 to 2,147,483,647	0000 hex
606C hex	00 hex	Velocity actual value	RO	INT32	Command units/s	–2,147,483,648 to 2,147,483,647	0000 hex
6077 hex	00 hex	Torque actual value	RO	INT16	0.1%	–5,000 to 5,000	0000 hex
60F4 hex	00 hex	Following error actual value	RO	INT32	Command units	–2,147,483,648 to 2,147,483,647	0000 hex
60FA hex	00 hex	Control effort	RO	INT32	Command units/s	–1,073,741,823 to 1073741823	0000 hex
60FC hex	00 hex	Position demand internal value	RO	INT32	Encoder units	–2,147,483,647 to 2,147,483,647	0

*1 The Following error window object can be set to between 0 and 134,217,728, or 4,294,967,295. If the object is set to 4,294,967,295, the detection of Following error will be disabled. If it is set to 0, a Following error will always occur. If the set value is between 134,217,729 and 4,294,967,294, it is assumed that 134,217,728 is set. In this case, 134,217,728 will be returned when the object is read.

*2 For the Servo Drive to accept commands without fail, the object value must always be retained for two communications cycles or more.

6-4-2 Description of Function

The G5-series Servo Drive can perform PTP positioning operation.

Set the Controlword (6040 hex) bit 5 (Change set immediately) to 1.

Setting the Target position (607A hex) and the Profile velocity (6081 hex) and then changing the Controlword (6040 hex) bit 4 (New set point) from 0 to 1 starts positioning to the set target position.

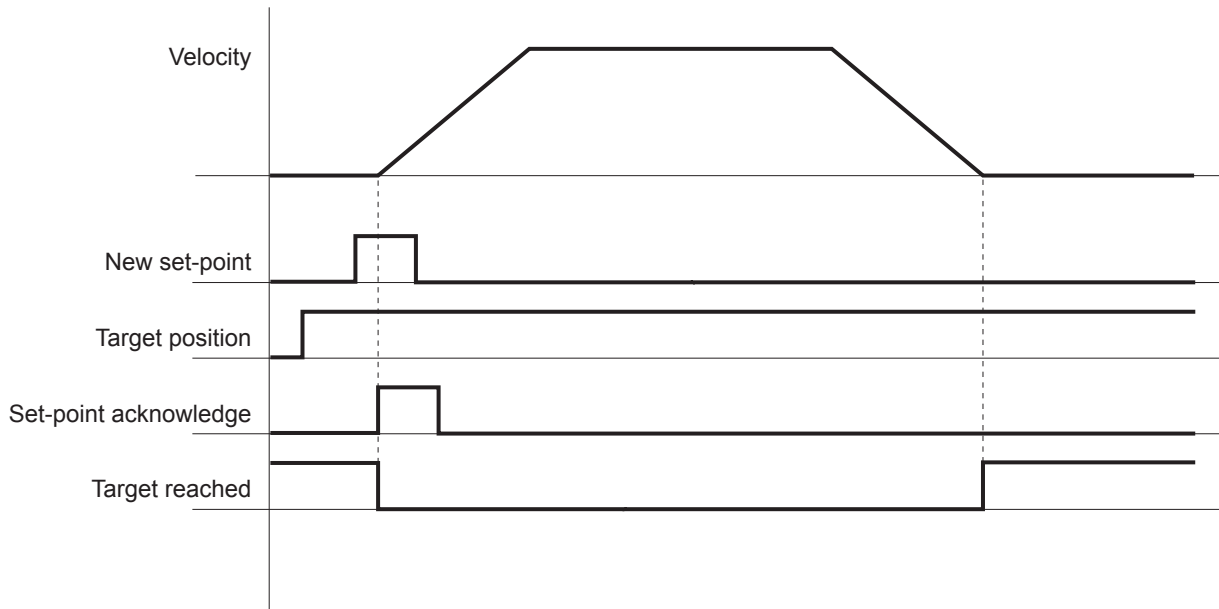

The Target value can be changed while PTP positioning is in progress.

During PTP positioning, changing the Target position (607A hex)/Profile velocity (6081 hex) value and then changing the Controlword (6040 hex) bit 4 (New set point) from 0 to 1 causes the G5-series Servo Drive to execute positioning with the changed value.

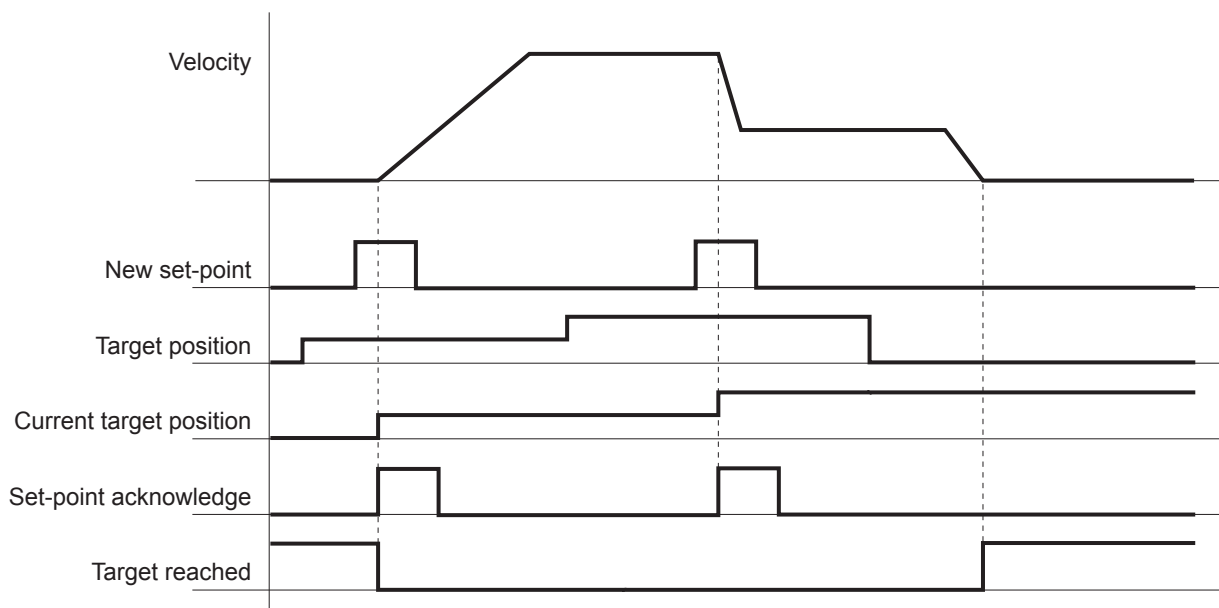

6-4-3 Controlword (6040 hex) in Profile Position Mode

Bit	Name	Description
4	New set-point	Starts positioning at the rising edge, from 0 to 1, of the signal. In this timing, the Target position (607A hex) and Profile velocity (6081 hex) values are obtained.
5	Change set immediately	Always set to 1 (Change set immediately). If set to 0, positioning does not occur due to a Command warning.
6	abs/rel	Always set to 0 (abs). If set to 1 (rel), positioning does not occur due to a Command warning.
8	Halt	When set to 0, positioning starts or continues. When set to 1, positioning stops according to the Halt option code (605D hex) setting.
9	Change on Set-point	Unused for G5-series Servo Drives.

6-4-4 Statusword (6041 hex) in Profile Position Mode

Bit	Name	Value	Description
10	Target reached	0	Halt bit is 0:Positioning is not completed. Halt bit is 1:The axis is decelerating.
		1	Halt bit is 0:Positioning is completed. Halt bit is 1:The axis speed is zero.
12	Set-point acknowledge	0	Waiting for a new Target position.
		1	Ready to accept updates (overwriting) of the Target position.
13	Following error	0	No Following error occurred.
		1	A Following error occurred.

6-5 Homing Mode

In this mode of operation, the Servo Drive has a path generation function (an operation profile calculation function) and it executes the homing operation using the Homing method specified from the controller.

When a controller is connected, the following two homing procedures are available depending on the controller specifications.

- Procedure 1
Create a homing operation pattern in the controller, and provide the command to the Servo Drive using Cyclic synchronous position mode (csp).
- Procedure 2
Use the Homing mode of the Servo Drive. The controller specifies a homing method supported by the Servo Drive and commands the start of the homing operation.

When performing the homing operation using the controller in procedure 1, refer to the operating manual for the controller.

When performing the homing operation using the controller in procedure 2, refer to the operating manual for the controller, and to *Homing Mode Specifications* on page A-15 of this manual.



Additional Information

Procedure 1 is used for the OMRON Machine Automation Controller NJ-series (Model: NJ501-1□00) and the CJ1W-NC281/NC481/NC881/NCF81/NC482/NC882 Position Control Units. Create a homing operation pattern in the Position Control Unit, provide the command to the Servo Drive using the Cyclic synchronous position mode (csp), and perform the homing operation.

6-6 Fully-closed Control

An externally provided encoder is used to directly detect the position of the control target and feedback the detected machine position to perform position control. This way, controls can be performed without being affected by ball screw error, temperature changes, etc. You can achieve highly accurate positioning by configuring a fully-closed control system.

6-6-1 Outline of Operation

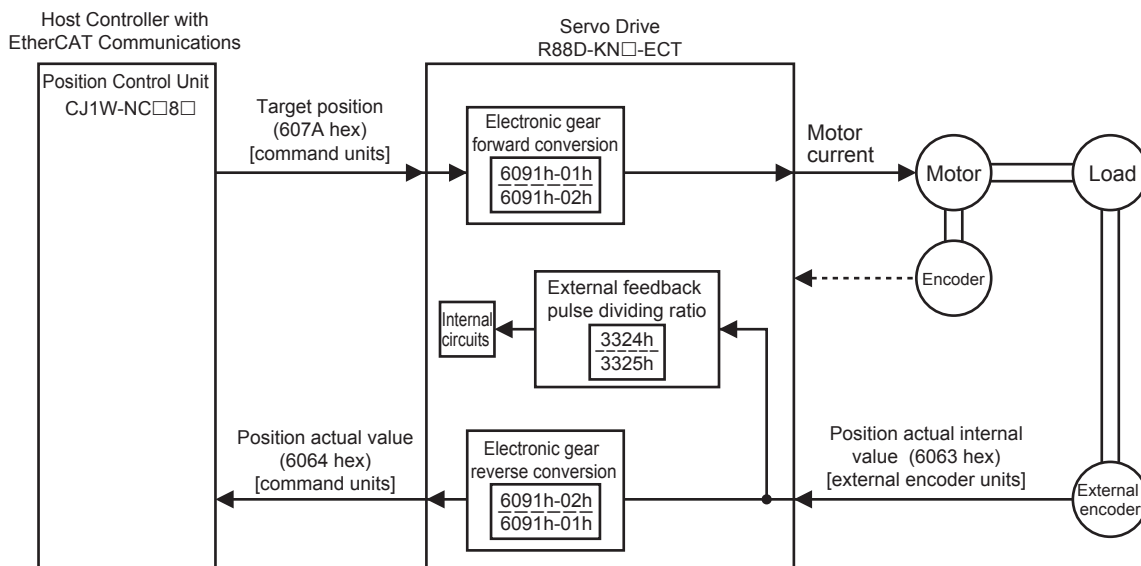

Note The electronic gear function is not supported for unit version 2.0. For the Servo Drives with unit version 2.0, set the electronic gear ratio to 1.1.



Additional Information

- If the Gear ratio (6091-01 and 6091-02 hex) is 1:1, 1 command unit from the Target position (607A hex) is equivalent to a movement of 1 external encoder pulse.

Example for an External Encoder with a Resolution of 0.1 μm

Gear ratio (6091-01 and 6091-02 hex) of 1:1:

The external encoder executes positioning for 10 μm when 100 command units are applied as the Target position (607A hex).

$$100 [\text{command units}] \times 1/1 (\text{electronic gear ratio}) \times 0.1 [\mu\text{m}] = 10 [\mu\text{m}]$$

Here, 100 command units are returned to the host controller as the Position actual value (6064 hex).

Gear ratio (6091-01 and 6091-02 hex) of 1:2:

The external encoder executes positioning for 10 μm when 200 command units are applied as the Target position (607A hex).

$$200 [\text{command units}] \times 1/2 (\text{electronic gear ratio}) \times 0.1 [\mu\text{m}] = 10 [\mu\text{m}]$$

Here, 200 command units are returned to the host controller as the Position actual value (6064 hex).

- Set the External Feedback Pulse Dividing Ratio (3324 and 3325 hex) according to *External Feedback Pulse Dividing Ratio Setting (3324 Hex, 3325 Hex)* on page 6-20.
- Set the Hybrid Following Error Counter Overflow Level (3328 hex) and Hybrid Following Error Counter Reset (3329 hex) according to *Hybrid Error Setting (3328 Hex, 3329 Hex)* on page 6-21.

- During fully-closed control, there are restrictions on the PDO sizes and communications cycle. For details, refer to *A-1-3 Communications Cycles and Corresponding Modes of Operation* on page A-5.

6-6-2 Objects Requiring Settings

Index	Sub-index	Name	Description	Reference
3000 hex	00 hex	Rotation Direction Switching	Set the relation between the command direction and the motor rotation direction.	page 9-2
3001 hex	00 hex	Control Mode Selection	Select the control mode.	page 9-3
6091 hex	01 hex	Motor revolutions	Set the numerator of the electronic gear ratio for the Target position (607A hex).	page A-92
6091 hex	02 hex	Shaft revolutions	Set the denominator of the electronic gear ratio for the Target position (607A hex).	
3323 hex	00 hex	External Feedback Pulse Type Selection	Select the external encoder type.	page 9-28
3324 hex	00 hex	External Feedback Pulse Dividing Numerator	Set the numerator of the external feedback pulse divider setting.	page 9-29
3325 hex	00 hex	External Feedback Pulse Dividing Denominator	Set the denominator of the external feedback pulse divider setting.	page 9-29
3326 hex	00 hex	External Feedback Pulse Direction Switching	Set the polarity of the external encoder feedback pulse.	page 9-29
3327 hex	00 hex	External Feedback Pulse Phase-Z Setting	Set whether to enable or disable the disconnection detection function for phase Z when an external encoder with a 90° phase difference output is used.	page 9-30
3328 hex	00 hex	Hybrid Following Error Counter Overflow Level	Set the threshold for the Excessive Hybrid Deviation Error (Error No. 25.0) in the command unit.	page 9-30
3329 hex	00 hex	Hybrid Following Error Counter Reset	The hybrid error becomes 0 every time the motor rotates by the set value.	page 9-30

Rotation Direction Switching (3000 Hex)

Set the relation between the command direction and the motor rotation direction.

0: Clockwise when viewed from the end of the shaft for positive commands

1: Counterclockwise when viewed from the end of the shaft for positive commands

When object 3000 hex is set to 1, opposite directions will be used for the external encoder counting direction and the total external encoder feedback pulses and other monitor counts.

Control Mode Selection (3001 Hex)

Select the fully-closed control (set value: 6).

Electronic Gear Function (6091-01 Hex, 6091-02 Hex)

This function sets the position command for the position control part to the value that is calculated by multiplying the command from the Host Controller with the electronic gear ratio.

Index	Name	Description	Setting range	Unit
6091-01 hex	Motor revolutions	Set the numerator of the electronic gear ratio for the command pulse input.	0 to 1,073,741,824	–
6091-02 hex	Shaft revolutions	Set the denominator of the electronic gear ratio for the command pulse input.	1 to 1,073,741,824	–

- For details on the electronic gear function, refer to *Electronic Gear Function* on page 7-21.

External Feedback Pulse Type Selection (3323 Hex, 3326 Hex)

Set the external encoder output type and direction.

Index	Name	Description	Setting range	Unit
3323 hex	External Feedback Pulse Type Selection	Select the type of the external encoder to be used. 0: Encoder with 90° phase difference output 1: Incremental encoder with serial communications 2: Absolute encoder with serial communications	0 to 2	–
3326 hex	External Feedback Pulse Direction Switching	If the count directions of the external encoder feedback pulse and the encoder total feedback pulses do not match, reverse the external encoder feedback pulse direction in this setting. 0: Not reversed, 1: Reversed	0 to 1	–

● Supported External Encoders

The corresponding external encoders for each output type are given in the following table.

Set value of 3323 hex	External encoder type	Corresponding external encoder examples	Maximum input frequency ^{*1}
0	Encoder with 90° phase difference output ^{*2*3}	External encoder with 90° phase difference output	0 to 4 Mpps (After x4)
1	Incremental encoder with serial communications ^{*3}	Sony Manufacturing Systems Corporation SR75, SR85	0 to 400 Mpps
2	Absolute encoder with serial communications ^{*3}	Mitutoyo Corporation AT573, ST771A, ST773A Sony Manufacturing Systems Corporation SR77, SR87	0 to 400 Mpps

*1 These are the feedback speeds from the external encoder at which Servo Drive can respond. Check the external encoder operation manual for its maximum output frequency.

- *2 These are the directions in which the Servo Drive counts the pulses from an external encoder with a 90° phase difference outputs.

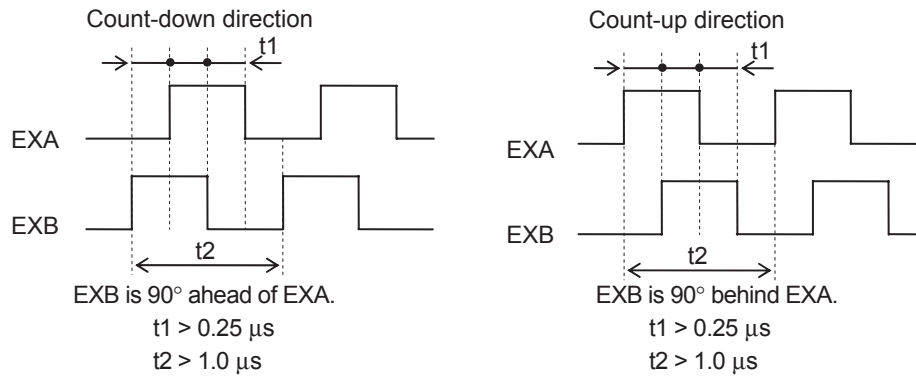

- *3 For the external encoder connection direction, set the direction so that count-up occurs when the motor shaft is rotating counterclockwise, and count-down occurs when the motor shaft is rotating clockwise. If the connection direction cannot be selected due to installation conditions or any other reason, the count direction can be reversed using External Feedback Pulse Direction Switching (3326 hex).



Precautions for Correct Use

- If 3000 hex = 1, the encoder count direction becomes opposite to the count direction used for monitoring, e.g., for the total external encoder feedback pulses. If 3000 hex = 0, the count direction matches the count direction for monitoring.
- Even when the speed command is within the Servo Drive's speed command range, an acceleration alarm will occur if the speed command exceeds the maximum speed of the motor.
- To confirm that the installation direction is correct, use the front-panel monitor or the CX-Drive monitor function to check the counting direction of the total external encoder feedback pulses and the total encoder feedback pulses. If the counting directions are the same, the connections are correct.



Additional Information

Maximum Input Frequency

- The maximum speed when an external encoder with a resolution of 0.01 μm is used for the serial communications is $0.01 \mu\text{m} \times (400 \times 10^6) \text{ pps} = 4.00 \text{ m/s}$. An overspeed error will occur, however, if the motor shaft rotation speed exceeds the maximum speed.

External Feedback Pulse Dividing Ratio Setting (3324 Hex, 3325 Hex)

Set the dividing ratio for the encoder resolution and external encoder resolution.

Index	Name	Description	Setting range	Unit
3324 hex	External Feedback Pulse Dividing Numerator	Set the numerator of the external feedback pulse divider setting. Normally, set the number of encoder output pulses per motor rotation. If the set value is 0, the encoder resolution is set automatically.	0 to 1,048,576	–
3325 hex	External Feedback Pulse Dividing Denominator	Set the denominator of the external feedback pulse divider setting. Normally, set the number of external encoder output pulses per motor rotation.	1 to 1,048,576	–

Check the number of encoder feedback pulses and the number of external encoder output pulses per motor rotation, and set the External Feedback Pulse Dividing Numerator (3324 hex) and External Feedback Pulse Dividing Denominator (3325 hex) so that the following equation is true.

$$\frac{\text{Object 3324 hex}}{\text{Object 3325 hex}} = \frac{\text{Encoder resolution per motor rotation [pulses]}}{\text{External encoder resolution per motor rotation [pulses]}}$$



Precautions for Correct Use

- If this divider setting is wrong, there will be error between the position calculated from encoder pulses and the position calculated from external encoder pulses. If the movement distance is long, this error accumulates and causes a Excessive Hybrid Deviation Error (Error No. 25.0).
- The recommended divider setting is $1/40 \leq \text{External Feedback Pulse Ratio} \leq 160$. If the ratio is set too small, control to the unit of 1 external feedback pulse may be disabled. On the other hand, if the external feedback pulse ratio is increased, operating noise may increase.

● Setting Example

- Ball screw pitch: 10 mm
- External encoder resolution: 0.1 μm
- Encoder resolution: 20 bits

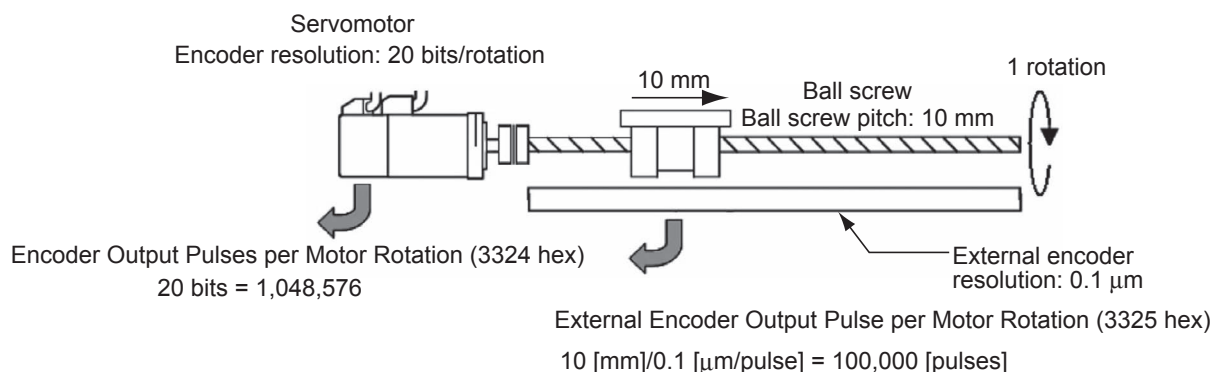

$$\frac{\text{Object 3324 hex}}{\text{Object 3325 hex}} = \frac{\text{Encoder resolution per motor rotation [pulses]}}{\text{External encoder resolution per motor rotation [pulses]}} = \frac{1048576}{100000}$$

Hybrid Error Setting (3328 Hex, 3329 Hex)

The difference between the encoder position and external encoder position is detected, and if the difference exceeds the value of Hybrid Following Error Counter Overflow Level (3328 hex), an error occurs.

Index	Name	Description	Setting range	Unit
3328 hex	Hybrid Following Error Counter Overflow Level	Set the allowable difference (hybrid error) between the encoder-detected position and external encoder-detected position in command units.	1 to 2^{27}	Command units
3329 hex	Hybrid Following Error Counter Reset	The hybrid error becomes 0 every time the motor rotates by the set value. If the set value is 0, the hybrid error is not cleared.	0 to 100	Rotations

● 3329 Hex: Hybrid Following Error Counter Reset

The hybrid error is cleared every time the motor rotates by the amount set in object 3329 hex.

This function can be used when there is error between the position calculated from encoder pulses and the position calculated from external encoder because hybrid error accumulated due to slipping or other factors.

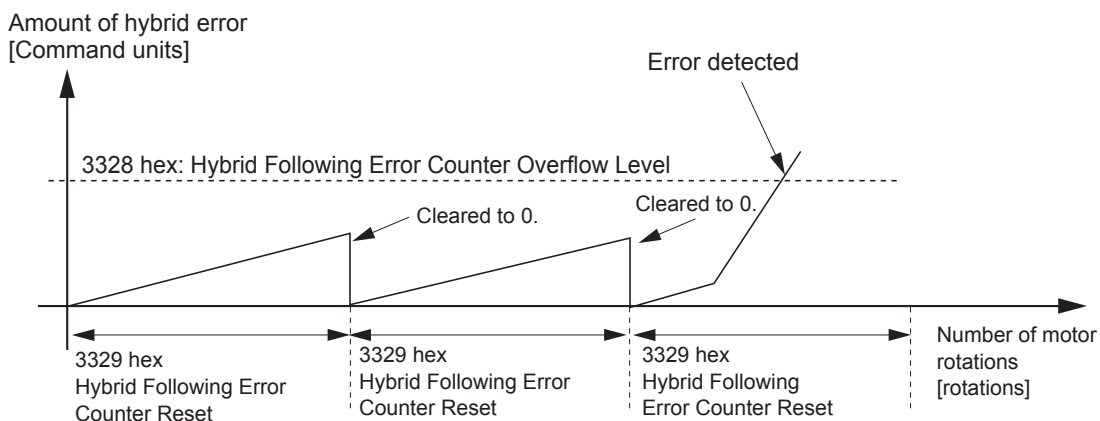

Precautions for Correct Use

- The machine may run out of control and be damaged if the external encoder breaks down or the motor or load coupling becomes disconnected. To prevent this from happening, set the Hybrid Following Error Counter Overflow Level (3328 hex) and Hybrid Following Error Counter Reset (3329 hex).
- If the Hybrid Following Error Counter Overflow Level (3328 hex) is set too high, detection is delayed and error detection will be ineffective. If an extremely small value is set, the amount of motor or machine torsion during normal operation may be detected as an error. Be sure to set an appropriate value.
- Take sufficient safety measures, such as installing limit sensors.

6-6-3 Block Diagram for Fully-closed Control Mode

The following is a block diagram for fully-closed control using an R88D-KN□□□-ECT-Series Servo Drive.

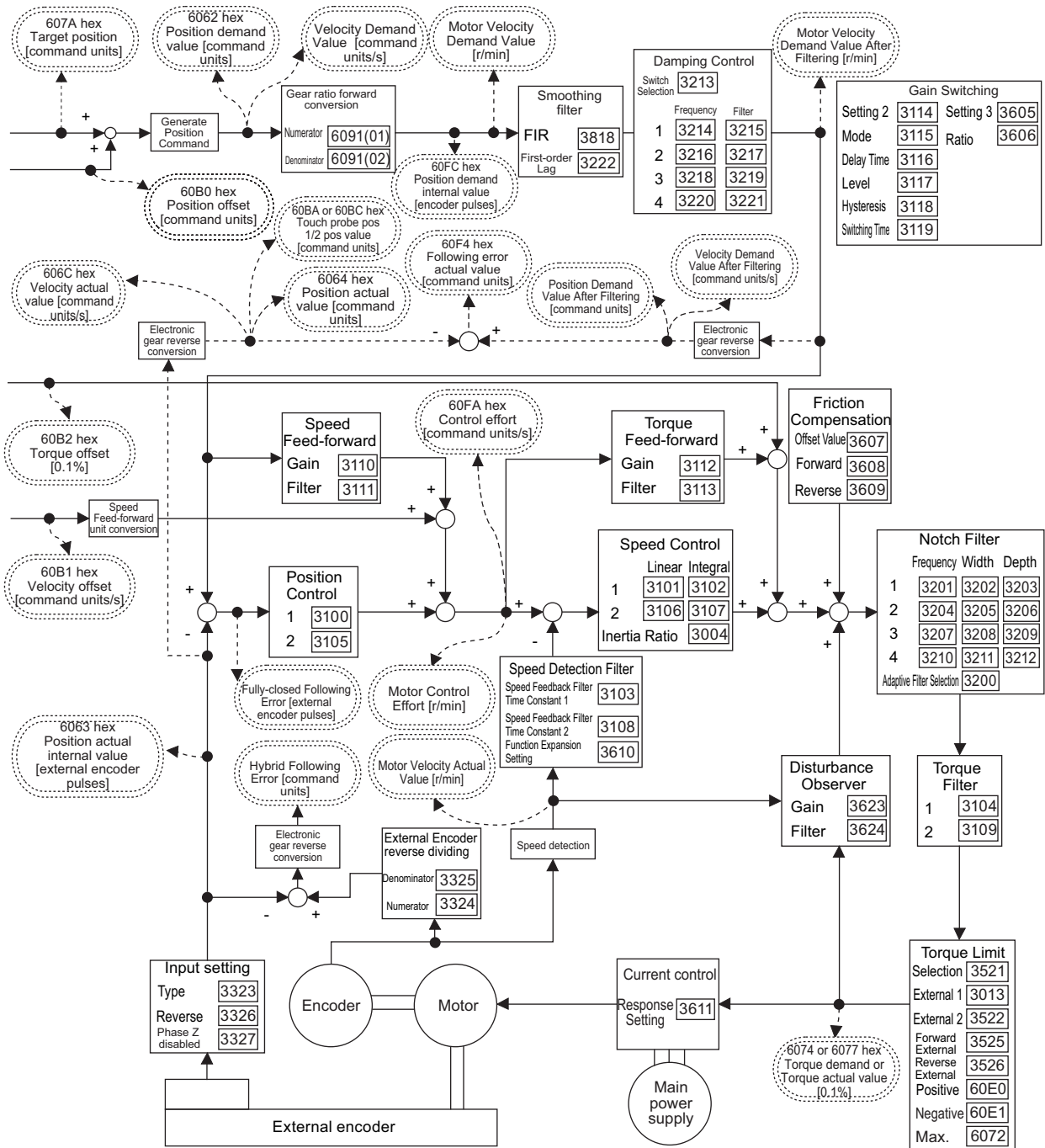

- Note 1** Numbers within parentheses are sub-index numbers.
2 Numbers within boxes are hexadecimal index numbers.
3 Profile position mode (pp) and Homing mode (hm) are also included in this block diagram.
4 Profile position mode (pp) is supported for unit version 2.1 or later.
5 The electronic gear function is not supported for unit version 2.0. For the Servo Drives with unit version 2.0, set the electronic gear ratio to 1.1.

6-7 Connecting with OMRON Controllers

This section describes the settings required to connect the G5-series Servo Drive with an OMRON controller.

Related Objects

The following tables give the set values for using the control functions of various Controllers. If you are changing these settings, read and understand the relevant specifications in advance and set appropriate values.

● Machine Automation Controller NJ-series (NJ501-1□00)

Index	Sub-index	Name	Recommended set value	Description
3013 hex	00 hex	External Torque Limit 1	1388 hex	Default setting = 500.0%
3015 hex	00 hex	Operation Switch When Using Absolute Encoder	0002 hex	Use absolute values and ignore multi-rotation counter overflow.
3317 hex	00 hex	Speed Limit Selection	0001 hex	Speed Limit during torque control is done using Max profile velocity (607F hex) or Speed Limit Value Setting (3321 hex), whichever has the smaller value.
3323 hex	00 hex	External Feedback Pulse Type Selection	–	If you use fully-closed control, set the external encoder type that is connected.
3324 hex	00 hex	External Feedback Pulse Dividing Numerator	00000000 hex	Encoder resolution is set automatically.
3401 hex	00 hex	Input Signal Selection 2	00818181 hex	Forward Drive Prohibition Input (NC)
3402 hex	00 hex	Input Signal Selection 3	00828282 hex	Reverse Drive Prohibition Input (NC)
3403 hex	00 hex	Input Signal Selection 4	00222222 hex	Origin Proximity Input (NO)
3404 hex	00 hex	Input Signal Selection 5	002B2B2B hex	External Latch Signal 3 (NO) ^{*1}
3405 hex	00 hex	Input Signal Selection 6	00212121 hex	External Latch Signal 2 (NO) ^{*1}
3406 hex	00 hex	Input Signal Selection 7	00202020 hex	External Latch Signal 1 (NO) ^{*1}
3504 hex	00 hex	Drive Prohibition Input Selection	0001 hex	The drive prohibition input is disabled in the servo and processed in the controller.
3508 hex	00 hex	Undervoltage Error Selection	0001 hex	Stopping for undervoltage errors.
3521 hex	00 hex	Torque Limit Selection	0006 hex	Use the 60E0 hex and 60E1 hex values to limit torque, with PCL and NCL OFF.
3522 hex	00 hex	External Torque Limit 2	1388 hex	Default setting = 500.0%
3703 hex	00 hex	Torque Limit Flag Output Setting	0001 hex	Turn ON at torque limits excluding the torque command value.
3801 hex	00 hex	Software Position Limit Function	0003 hex	Disable the software limits in both directions.
3758 hex	00 hex	Touch Probe Trigger Selection	0100 hex	Touch probe1 = External Latch Signal 1 Touch probe2 = External Latch Signal 2
3759 hex	00 hex	Warning Hold Selection	0000 hex	Automatically cleared when the cause is removed.
607C hex	00 hex	Home offset	00000000 hex	An offset value of 0 is used by the Servo Drive.
6091 hex	01 hex	Motor revolutions	00000001 hex	Gear ratio used by the Servo Drive is 1:1, and user units are handled by the controller.
	02 hex	Shaft revolutions	00000001 hex	

- *1 Machine Automation Controller NJ-series (Model: NJ501-1□00) uses the latch signals as follows:
 External Latch Signal 1: Trigger signal from external Touch probe function (External Latch Input 1)
 External Latch Signal 2: Trigger signal from external Touch probe function (External Latch Input 2)
 External Latch Signal 3: Unused



Precautions for Correct Use

If you connect an NJ-series Controller and use the ResetECError instruction, use exclusive control so that the following instructions are not executed at the same time.

- ResetMCErr, MC_Reset, and MC_GroupReset

● CJ1W-NC281/NC481/NC881/NCF81/NC482/NC882 Position Control Units

Index	Sub-index	Name	Default setting	Description
3013 hex	00 hex	External Torque Limit 1	1388 hex	Default setting = 500.0%
3015 hex	00 hex	Operation Switch When Using Absolute Encoder	0002 hex	Use absolute values and ignore multi-rotation counter overflow.
3323 hex	00 hex	External Feedback Pulse Type Selection	–	If you use fully-closed control, set the external encoder type that is connected.
3324 hex	00 hex	External Feedback Pulse Dividing Numerator	00000000 hex	Encoder resolution is set automatically.
3401 hex	00 hex	Input Signal Selection 2	00818181 hex	Forward Drive Prohibition Input (NC)
3402 hex	00 hex	Input Signal Selection 3	00828282 hex	Reverse Drive Prohibition Input (NC)
3403 hex	00 hex	Input Signal Selection 4	00222222 hex	Origin Proximity Input (NO)
3404 hex	00 hex	Input Signal Selection 5	002B2B2B hex	External Latch Signal 3 (NO) ^{*1}
3405 hex	00 hex	Input Signal Selection 6	00212121 hex	External Latch Signal 2 (NO) ^{*1}
3406 hex	00 hex	Input Signal Selection 7	00202020 hex	External Latch Signal 1 (NO) ^{*1}
3504 hex	00 hex	Drive Prohibition Input Selection	0001 hex	The drive prohibition input is disabled in the servo and processed in the controller.
3508 hex	00 hex	Undervoltage Error Selection	0001 hex	Stopping for undervoltage errors.
3521 hex	00 hex	Torque Limit Selection	0006 hex	Both forward and reverse directions have two limits which are switched using PCL and NCL.
3522 hex	00 hex	External Torque Limit 2	1388 hex	Default setting = 500.0%
3801 hex	00 hex	Software Position Limit Function	0003 hex	Disable the software limits in both directions.
3758 hex	00 hex	Touch Probe Trigger Selection	0100 hex	Touch probe1 = External Latch Signal 1 Touch probe2 = External Latch Signal 2
3759 hex	00 hex	Warning Hold Selection	0000 hex	Automatically cleared when the cause is removed.
607C hex	00 hex	Home offset	00000000 hex	An offset value of 0 is used by the Servo Drive.
6091 hex	01 hex	Motor revolutions	00000001 hex	Gear ratio used by the Servo Drive is 1:1, and user units are handled by the controller.
	02 hex	Shaft revolutions	00000001 hex	
60E0 hex	00 hex	Positive torque limit value	1388 hex	Default setting = 500.0%
60E1 hex	00 hex	Negative torque limit value	1388 hex	Default setting = 500.0%

- *1 The CJ1W-NC□8□ uses the latch signals as follows:
 External Latch Signal 1: Origin Input
 External Latch Signal 2: Interrupt Input
 External Latch Signal 3: Not used.



Applied Functions

This chapter outlines the applied functions such as the electronic gear, gain switching and soft start, and explains the settings.

7-1	Sequence I/O Signals	7-2
7-1-1	Input Signals	7-2
7-1-2	Output Signals	7-5
7-2	Forward and Reverse Drive Prohibition Functions	7-8
7-2-1	Objects Requiring Settings	7-8
7-3	Overrun Protection	7-11
7-3-1	Operating Conditions	7-11
7-3-2	Objects Requiring Settings	7-11
7-3-3	Operation Example	7-12
7-4	Backlash Compensation	7-13
7-4-1	Objects Requiring Settings	7-13
7-5	Brake Interlock	7-15
7-5-1	Objects Requiring Settings	7-15
7-5-2	Operation Timing	7-16
7-6	Electronic Gear Function	7-21
7-6-1	Objects Requiring Settings	7-21
7-6-2	Operation Example	7-22
7-7	Torque Limit Switching	7-24
7-7-1	Operating Conditions	7-24
7-7-2	Objects Requiring Settings	7-24
7-8	Soft Start	7-26
7-8-1	Objects Requiring Settings	7-26
7-8-2	Soft Start Acceleration or Deceleration Time	7-26
7-8-3	S-curve Acceleration or Deceleration Time	7-27
7-9	Gain Switching Function	7-28
7-9-1	Objects Requiring Settings	7-29
7-9-2	Gain Switching Based on the Control Mode	7-30
7-9-3	Diagrams of Gain Switching Setting	7-35
7-9-4	Position Gain Switching Time (3119 Hex)	7-37
7-10	Gain Switching 3 Function	7-38
7-10-1	Operating Conditions	7-38
7-10-2	Objects Requiring Settings	7-38
7-10-3	Operation Example	7-38
7-11	Touch Probe Function (Latch Function)	7-40
7-11-1	Related Objects	7-40
7-11-2	Trigger Signal Settings	7-40
7-11-3	Operation Sequences	7-41

7-1 Sequence I/O Signals

You can set sequences in various operating conditions.

For the connection of I/O signals and processing of external signals, refer to *3-1-6 Control I/O Connector Specifications (CN1)* on page 3-18.

7-1-1 Input Signals

You can allocate input signal functions to the input pins of the control I/O connector (CN1). In addition, you can change logic. Refer to *Input Signal Allocation Method* on page 7-3 for more information because some signals have allocation limitations.

If a G-series Servo Drive is being replaced with a G5-series Servo Drive, use the G5-series Servo Drive with the default settings.

Input Signal Default Settings

The allocations of the default input signals are as follows. Refer to *Input Signal Allocation Method* on page 7-3 to change the allocations.

Index	Input signal	Default setting (hex)	Default setting state					
			Position control or fully-closed control		Speed control		Torque control	
			Signal name	Logic ^{*1}	Signal name	Logic ^{*1}	Signal name	Logic ^{*1}
3400 hex	IN1	0094 9494 hex	STOP	NC	STOP	NC	STOP	NC
3401 hex	IN2	0081 8181 hex	POT	NC	POT	NC	POT	NC
3402 hex	IN3	0082 8282 hex	NOT	NC	NOT	NC	NOT	NC
3403 hex	IN4	0022 2222 hex	DEC	NO	DEC	NO	DEC	NO
3404 hex	IN5	002B 2B2B hex	EXT3	NO	EXT3	NO	EXT3	NO
3405 hex	IN6	0021 2121 hex	EXT2	NO	EXT2	NO	EXT2	NO
3406 hex	IN7	0020 2020 hex	EXT1	NO	EXT1	NO	EXT1	NO
3407 hex	IN8	002E 2E2E hex	MON0	NO	MON0	NO	MON0	NO

^{*1} NO (normally open) and NC (normally close) in the table above refer to the following states.

- NO: Disabled (OFF) when signal input is open with COM–
Enabled (ON) when signal input is shorted with COM–
- NC: Disabled (OFF) when signal input is shorted with COM–
Enabled (ON) when signal input is open with COM–

Objects That Can Be Assigned

Use the following objects when changing the input signal allocations.

For the setting method, refer to *Input Signal Allocation Method* on page 7-3.

Index	Name	Explanation	Reference
3400 hex	Input Signal Selection 1	Set the IN1 input function allocation. This object is based on hexadecimal. (The display on the front panel is based on decimal.)	page 9-31
3401 hex	Input Signal Selection 2	Set the IN2 input function allocation.	page 9-31
3402 hex	Input Signal Selection 3	Set the IN3 input function allocation.	page 9-31
3403 hex	Input Signal Selection 4	Set the IN4 input function allocation.	page 9-31
3404 hex	Input Signal Selection 5	Set the IN5 input function allocation.	page 9-31
3405 hex	Input Signal Selection 6	Set the IN6 input function allocation.	page 9-32
3406 hex	Input Signal Selection 7	Set the IN7 input function allocation.	page 9-32
3407 hex	Input Signal Selection 8	Set the IN8 input function allocation.	page 9-32

Input Signal Allocation Method

Input the setting for each control mode to any of the objects from 3400 to 3407 hex to allocate the signals.

Set the objects using hexadecimal.

Set the set value of the function for each control mode in “***” below.

Refer to the function number table provided later for the set value of each function. The logic setting is included in the function numbers.

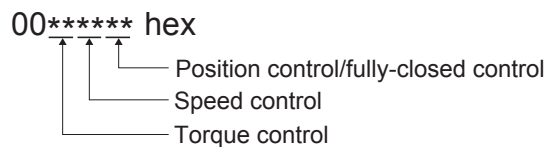

Example:

Position control or fully-closed control: Monitor Input 0 with NO (normally open) contacts (2E hex)

Speed control: Disabled (00 hex)

Torque control: Positive External Torque Limit Input with NO contacts (2C hex)

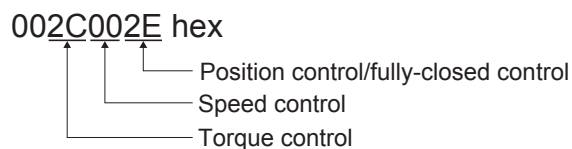

● Function Number Table

The set values to be used for allocations are as follows:

Signal name	Symbol	Set value	
		NO	NC
Disabled	–	00 hex	Setting not available
Forward Drive Prohibition Input	POT	01 hex	81 hex
Reverse Drive Prohibition Input	NOT	02 hex	82 hex
Immediate Stop Input	STOP	14 hex	94 hex
External Latch Input 1	EXT1	20 hex	Setting not available
External Latch Input 2	EXT2	21 hex	Setting not available
Origin Proximity Input	DEC	22 hex	A2 hex
External Latch Input 3	EXT3	2B hex	Setting not available
Forward External Torque Limit Input	PCL	2C hex	AC hex
Reverse External Torque Limit Input	NCL	2D hex	AD hex
Monitor Input 0	MON0	2E hex	AE hex
Monitor Input 1	MON1	2F hex	AF hex
Monitor Input 2	MON2	30 hex	B0 hex



Precautions for Correct Use

- Do not use any settings other than the settings listed.
- Do not allocate the same function to more than one input signal. If you allocate the same function to more than one input signal, and Interface Input Duplicate Allocation Error 1 (Error No. 33.0) or Interface Input Duplicate Allocation Error 2 (Error No. 33.1) will occur.
- The External Latch Inputs 1, 2, and 3 (EXT1, EXT2 and EXT3) can be allocated only to IN5 to IN7. If you allocate them to any other inputs, an External Latch Input Allocation Error (Error No. 33.8) will occur.
- If you use the External Latch Input 1, 2, or 3 (EXT1, EXT2 or EXT3), you must set it for all control modes. Otherwise, an External Latch Input Allocation Error (Error No. 33.8) will occur.
- The External Latch Inputs 1, 2, and 3 (EXT1, EXT2 and EXT3) can be set only to NO (normally open) contacts.
- The control input pins that are disabled do not affect the operation.
- The functions that are used by more than one control mode, such as Immediate Stop Input, and Origin Proximity Input, must be allocated to the same pin, in the same logic. If they are allocated to different pins, an Interface Input Duplicate Allocation Error 1 (Error No. 33.0) or an Interface Input Duplicate Allocation Error 2 (Error No. 33.1) will occur. If the logic is inconsistent, an Interface Input Function Number Error 1 (Error No. 33.2) or an Interface Input Function Number Error 2 (Error No. 33.3) will occur.

7-1-2 Output Signals

You can allocate output signal functions to the output pins for the control I/O connector (CN1).

If a G-series Servo Drive is being replaced with a G5-series Servo Drive, use the G5-series Servo Drive to with the default settings.

Output Signal Default Setting

The allocations of the default output signals are as follows. Refer to *Output Signal Allocation Method* on page 7-6 to change the allocations.

Index	Output signal	Default setting (hex)	Default setting state					
			Position control or fully-closed control		Speed control		Torque control	
			Signal name	Logic *1	Signal name	Logic *1	Signal name	Logic *1
3410 hex	OUTM1	0003 0303 hex	BKIR	NO	BKIR	NO	BKIR	NO
3411 hex	OUTM2	0002 0202 hex	READY	NO	READY	NO	READY	NO

*1 NO (normally open) and NC (normally close) refer to the following states.

NO: When the function is disabled (OFF state), output transistor is OFF.

When the function is enabled (ON state), output transistor is ON.

NC: When the function is disabled, output transistor is ON.

When the function is enabled, output transistor is OFF.

Objects That Can Be Assigned

Use the following objects when changing the output signal allocations.

For the setting method, refer to *Output Signal Allocation Method* on page 7-6.

Index	Object name	Explanation	Reference
3410 hex	Output Signal Selection 1	Set the OUTM1 output function allocation. This object is set in hexadecimal. Refer to the output signal function number table for details.	page 9-32
3411 hex	Output Signal Selection 2	Set the OUTM2 output function allocation.	page 9-32

Output Signal Allocation Method

Input the setting for each control mode to objects 3410 and 3411 hex to allocate the signals.

Set the objects based on hexadecimal in the same manner as for the input signal allocations.

Set the set value of the function for each control mode in “***” below.

Refer to the function number table provided below for the set value of each function. The logic setting is included in the function numbers.

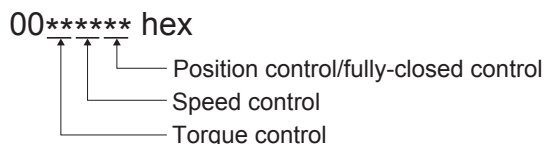

Example:

Position control or fully-closed control: Position command output (0B hex)

Speed control: Motor rotation speed detection output (05 hex)

Torque control: Zero speed detection signal (07 hex)

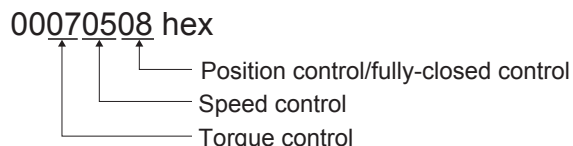

● Function Number Table

The set values to be used for allocations are as follows:

Signal name	Symbol	Set value	
		NO (or normally open) contact	NC (or normally close) contact
Disabled	–	00 hex	00 hex
Servo Ready Completed Output	READY	02 hex	82 hex
Brake Interlock Output	BKIR	03 hex	Setting not available
Positioning Completion Output	INP1	04 hex	84 hex
Motor Rotation Speed Detection Output	TGON	05 hex	85 hex
Torque Limit Output	TLIMIT	06 hex	86 hex
Zero Speed Detection Output	ZSP	07 hex	87 hex
Speed Conformity Output	VCMP	08 hex	88 hex
Warning Output 1	WARN1	09 hex	89 hex
Warning Output 2	WARN2	0A hex	8A hex
Position Command Status Output	PCMD	0B hex	8B hex
Positioning Completion Output 2	INP2	0C hex	8C hex
Speed Limiting Output	VLIMIT	0D hex	8D hex
Error Clear Attribute Output	ALM-ATB	0E hex	8E hex
Speed Command Status Output	VCMD	0F hex	8F hex
Remote Output 1	R-OUT1	10 hex	Setting not available
Remote Output 2	R-OUT2	11 hex	Setting not available



Precautions for Correct Use

- Do not use any settings other than the settings listed.
 - You can allocate the same function to more than one output signal.
 - When you disable the control output pin, the output transistor always stays OFF.
 - If you use the Brake Interlock Output (BKIR), you must set the function in all control modes. Otherwise, an Interface Output Function Number Error 1 (Error No. 33.4) or an Interface Output Function Number Error 2 (Error No. 33.5) will occur.
 - The Brake Interlock Output (BKIR) can be set only to NO (normally open) contacts.
-

7-2 Forward and Reverse Drive Prohibition Functions

If the Forward Drive Prohibition Input (POT) or the Reverse Drive Prohibition Input (NOT) is turned OFF, the motor will stop rotating.

You can thus prevent the motor from rotation outside of the movement range of the device by using limit inputs from the device connected to the Servo Drive.

7-2-1 Objects Requiring Settings

Index	Name	Explanation	Reference
3400 hex to 3407 hex	Input Signal Selection 1 to 8	Set the input signal allocations and logic.	page 9-31
3504 hex	Drive Prohibition Input Selection	Set the operation to be performed upon forward and reverse drive prohibition input.	page 9-41
3505 hex	Stop Selection for Drive Prohibition Input	Set the deceleration and stop methods upon forward and reverse drive prohibition input.	page 9-42
3511 hex	Immediate Stop Torque	Set the torque limit for immediate stops.	page 9-43

Input Signal Selection Function (Default Settings: 3401 Hex, 3402 Hex)

In the default settings, the allocations are as follows.

Index	Name	Default setting	
		Set value	Position Control or fully-closed control
3401 hex	Input Signal Selection 2	0081 8181 hex	POT (NC)
3402 hex	Input Signal Selection 3	0082 8282 hex	NOT (NC)

- Refer to *7-1 Sequence I/O Signals* on page 7-2 for details on input signal selections 1 to 8.

Drive Prohibition Input Selection (3504 Hex)

Set the operation of the Forward Drive Prohibition Input (POT) and the Reverse Drive Prohibition Input (NOT). Install limit switches at both ends of the axis to prohibit the Servomotor from driving in the direction specified by the switch. This can be used to prevent the workpiece from driving too far and thus prevent damage to the machine. Set the operation to be performed upon forward and reverse drive prohibition input.

Drive Prohibition Input Selection (3504 hex)	Explanation
0	<p>Forward drive prohibition input and reverse drive prohibition input enabled.</p> <p>The operation when a signal is input is as follows:</p> <p>Forward drive prohibition input closed: Forward limit switch not operating and status normal.</p> <p>Forward drive prohibition input open: Forward direction prohibited and reverse direction permitted.</p> <p>Reverse drive prohibition input closed: Reverse limit switch not operating and status normal.</p> <p>Reverse drive prohibition input open: Reverse direction prohibited and forward direction permitted.</p> <p>The Servomotor decelerates and stops according to the sequence set in Stop Selection for Drive Prohibition Input (3505 hex).^{*1}</p> <p>If the forward and the reverse prohibition inputs are both open, a Drive Prohibition Input Error 1 (Error No. 38.0) will occur because it is taken that Servo Drive is in error condition.</p>
1	Forward and reverse drive prohibition input disabled.
2	<p>Forward and reverse drive prohibition input enabled.</p> <p>If either the forward or the reverse prohibition input is open, a Drive Prohibition Input Error 1 (Error No. 38.0) will occur.</p>

*1 For details, refer to explanation for Stop Selection for Drive Prohibition Input (3505 hex).



Precautions for Correct Use

Both signals are disabled (in a state in which drive prohibition will not operation) in the default settings. If prohibiting the drive input is required, set the Drive Prohibit Input Selection (3504 hex) to either 0 or 2. The setting on the Input Signal Selection 1 to 10 (3400 to 3409 hex) can change the logic and allocation for the respective Input terminals (CN1 to 7 and 8).

Stop Selection for Drive Prohibition Input (3505 Hex)

Set the deceleration and stop methods upon a forward or reverse drive prohibition is input.

3504 hex set value ^{*1}	3505 hex set value	Decelerating ^{*2}		After stopping	
		Deceleration method	Error counter	Operation after stop	Error counter
0	0	Dynamic brake	Clear	Torque command = 0 for drive prohibition direction	Held
	1	Free-run	Clear	Torque command = 0 for drive prohibition direction	Held
	2	Immediate stop ^{*3}	Clear	Torque command and torque limit are as specified.	Cleared after deceleration completes, then held.

*1 If the Drive Prohibition Input Selection (3504 hex) is set to 2, a Drive Prohibition Input Error (Error No. 38.0) will occur as soon as either the Forward or Reverse Drive Prohibition Input becomes open. The subsequent operation conforms not to the set value, but to the setting of the Fault reaction option code (605E hex). In the same way, the Fault reaction option code (605E hex) takes priority when any other error occurs.

- *2 The term “During deceleration” means the distance until the motor decreases its speed to 30 r/min or less from the normal operation. Once it decelerates to 30 r/min or lower, the operation conforms to the description for “post-stopping”, regardless of the actual motor speed.
- *3 “Immediate Stop” means that the Servomotor stops immediately by using controls while the servo is kept ON. The torque limit at this time is controlled by the Immediate Stop Torque (3511 hex) set value.

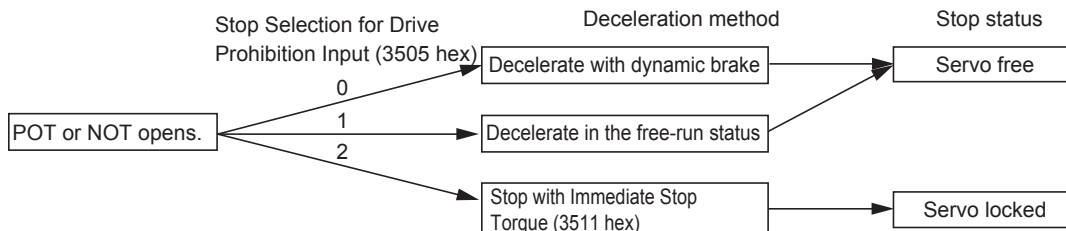

Precautions for Correct Use

- At an immediate stop, an Error Counter Overflow (Error No. 24.0) or an Overrun Limit Error (Error No. 34.0) may occur. This is because the immediate stop forces the motor to decelerate quickly, and the position control creates a large position error momentarily. If an error occurs, set the Following error window (6065 hex) and the Overrun Limit Setting (3514 hex) to appropriate values.
- A load on the vertical axis and so forth may fall due to its own weight in the drive prohibition input state. To prevent the load from falling, set deceleration with the immediate stop torque and stopping with a servo lock (set value: 2) in the Stop Selection for Drive Prohibition Input (3505 hex), or limit the operation using the Host Controller rather than using this function.
- A Command Warning (Warning No. B1 hex) will occur if a command is given in the drive prohibition direction while the Servomotor is stopped (i.e., decreases the speed to 30 r/min or lower) and the Drive Prohibition Input is open.



Additional Information

While the Forward Drive Prohibition Input (POT) is open, the Servomotor cannot be driven in the forward direction, but it can be driven in the reverse direction. Conversely, while the Reverse Drive Prohibition Input (NOT) is open, the Servomotor cannot be driven in the reverse direction, but it can be driven in the forward direction.

Immediate Stop Torque (3511 Hex)

This is the torque limit when the Stop Selection for Drive Prohibition Input (3505 hex) is set to 2, and the Servomotor decelerates due to a drive prohibition input. The settable range is 0 to 500% in units of 0.1%. When it is set to 0%, the normal torque limit is used.

7-3 Overrun Protection

This function detects an Overrun Limit Error (Error No. 34.0) and stops the Servomotor if the motor exceeds the allowable operating range set for the Overrun Limit Setting (3514 hex) with respect to the position command input.

The function can also prevent the Servomotor from clash into the machine edge due to vibration.

7-3-1 Operating Conditions

The overrun limit works under the following conditions.

	Conditions
Operating Mode	Position Control Mode, Fully-closed Control Mode
Others	<ul style="list-style-type: none"> Servo ON state The factors other than control objects must be set correctly. This includes the torque limit. The motor must operate normally without any failures.

Conditions for Clearing the Position Command Input Range

The position command input range will be cleared to zero under any of the following conditions.

- When the power supply is turned ON,
- While the position error is cleared. This includes when the servo is OFF and when the error counter is cleared due to a deceleration stop for the drive prohibit input.
- When a trial operation via USB communications starts and when it ends.
- When the position data is initialized. This includes at a component setup request, at an origin return, when setting the coordinate system, at an adjustment command, and when clearing a multi-rotation data via USB.



Precautions for Correct Use

- This function is not intended to protect against incorrect position commands.
- When this function works, the Servomotor decelerates and stops according to the Fault reaction option code (605E hex). Take this deceleration operation into account when you set the Overrun Limit Setting (3514 hex). Otherwise, the load during deceleration may hit and cause damage to the machine edges.
- The overrun limit function is disabled for FFT analysis from the CX-Drive.

7-3-2 Objects Requiring Settings

Index	Name	Description	Reference page
3514 hex	Overrun Limit Setting	Sets the Servomotor's allowable operating range for the position command input range.	page 9-43

7-3-3 Operation Example

No Position Command Input (Servo ON)

No position command is entered. The Servomotor's allowable operating range is the range set in object 3514 hex on both the right and left. An overrun limit error will occur (Error No. 34.0) if the load enters the error range, or the shaded area in the drawing below, due to vibration.

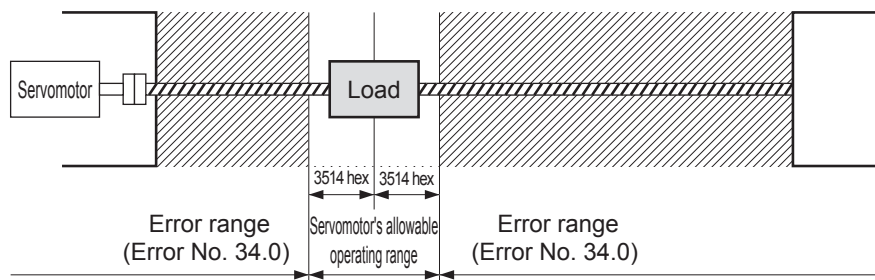

Right Side Operation (Servo ON)

When a rightward position command is entered, the Servomotor's allowable operating range increases for the commanded amount. The range will be the result where the rotation set for 3514 hex is added on both sides for the position command.

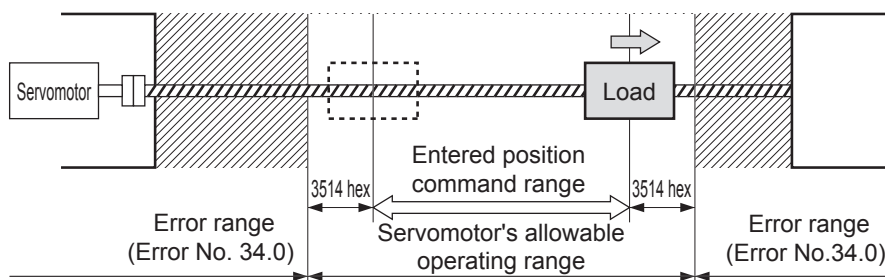

Left Side Operation (Servo ON)

When a leftward position command is entered, the Servomotor's allowable operating range further increases.

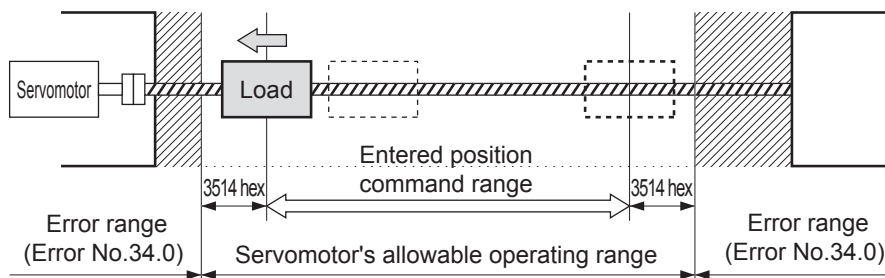

7-4 Backlash Compensation

The function compensates for backlash for position control and fully-closed control.

7-4-1 Objects Requiring Settings

Index	Name	Description	Reference page
3704 hex	Backlash Compensation Selection	Select whether to enable or disable backlash compensation during position control. Set the compensation direction.	page 9-55
3705 hex	Backlash Compensation Amount	Set the compensation amount during position control.	page 9-55
3706 hex	Backlash Compensation Time Constant	Set the backlash compensation time constant during position control.	page 9-55

Backlash Compensation Selection (3704 Hex)

This object is used to select whether to enable or disable backlash compensation during position control, and to set the compensation direction.

Set value	Description
0	Disable backlash compensation.
1	Compensate for backlash at the first forward operation after the servo is turned ON.
2	Compensate for backlash at the first reverse operation after the servo is turned ON.

Setting Method

The backlash compensation works in different directions depending on the setting in the Backlash Compensation Selection (3704 hex) and on whether the set value for the Backlash Compensation Amount (3705 hex) is positive or negative.

3704 hex	3705 hex contains a positive value	3705 hex contains a negative value
1	Compensate in positive direction when operation is in forward.	Compensate in negative direction when operation is in forward.
2	Compensate positive direction when it is in reverse operation.	Compensate in negative directions when operation is in reverse.



Precautions for Correct Use

- To determine the actual position of the Servomotor, offset the Servomotor position data acquired via EtherCAT communications by the backlash compensation amount.
 - Backlash compensation is performed on the first position command in the set direction after the servo is turned ON. Any prior operations in the opposite direction are not compensated. But the first reverse operation after the initial backlash compensation is compensated. Backlash compensation is not performed again as long as the operation continues in the same direction.
 - When the Servo OFF status occurs while backlash compensation is performed, the backlash compensation amount is cleared. This is done by presetting the position command data of the Servo Drive to the Servomotor position data that includes the backlash compensation amount. When the servo is turned ON again, backlash compensation is performed as described above.
-



Additional Information

Conditions for Clearing Backlash Compensation

- When the position error is reset. This includes when the servo is turned OFF, and when the error counter is reset for the drive prohibition input.
 - When the position data is initialized, except for the homing operation in Homing mode (hm). This includes Config (4100 hex) and Absolute Encoder Setup (4102 hex).
-

7-5 Brake Interlock

This function lets you set the output timing for the brake interlock output (BKIR) that activates the holding brake when the servo is turned ON, an error occurs, or the servo is turned OFF.

It is also possible to use the controller's function to force the brake control via EtherCAT communications. However, it is not supported on the OMRON Machine Automation Controller NJ-series (Model: NJ501-1□00) and CJ1W-NC□81/□82 Position Control Unit.

7-5-1 Objects Requiring Settings

Index	Sub-index	Bit	Name	Explanation	Reference
3437 hex	–	–	Brake Timing when Stopped	Set the time after a servo OFF command is issued upon servo lock stop, until the brake interlock output (BKIR) turns OFF and power supply stops.	page 9-38
3438 hex	–	–	Brake Timing During Operation	Set the time after a servo OFF command is issued while the motor is rotating, until the brake interlock output (BKIR) turns OFF and power supply stops. If the speed drops to or below the value set in object 3439 hex before the time set here, BKIR will turn OFF.	page 9-39
3439 hex	–	–	Brake Threshold Speed During Operation	Set the speed at which to turn OFF power to the Servomotor when the Brake Interlock Output (BKIR) signal turns OFF after execution of a servo OFF command while the Servomotor is rotating. If the time set in object 3438 hex elapses before the Servomotor drops to the speed set here, BKIR will turn OFF.	page 9-39
60FE hex	01 hex	0		This is the Set Brake Bit for EtherCAT communications. 0: Brake released* ¹ 1: Brake engaged* ²	page A-93
	02 hex	0		This is the Set Brake Mask Bit for enabling/disabling the Set Brake Bit for EtherCAT communications. 0: Set Brake Bit enabled. 1: Set Brake Bit disabled.	

*1 The Brake Interlock Output (BKIR) is turned ON. The brake is released for a brake release command from either EtherCAT communications or the Servo Drive.

*2 The Brake Interlock Output (BKIR) is turned OFF. The brake is engaged only when a set brake command is received from both EtherCAT communications and the Servo Drive.

Applying the brake from EtherCAT communications is enabled only while the servo is OFF. If a Set Brake command is received while the servo is ON, a Command Warning (B1 hex) will occur.



Precautions for Correct Use

- The brake on a Servomotor with a brake is a normally closed brake designed only to hold when the operation is stopped. Accordingly, set an appropriate time so that the brake actuates after the motor stops.
- If the brake is engaged while the Servomotor is rotating, the brake disc will wear abnormally or sustain damage, resulting in a bearing or encoder failure in the Servomotor.
- The workpiece may fall when the brake is released for a vertical axis. Carefully consider the timing of releasing the brake.

7-5-2 Operation Timing

This section shows the timing of the Brake Interlock Output (BKIR).

Basic Timing

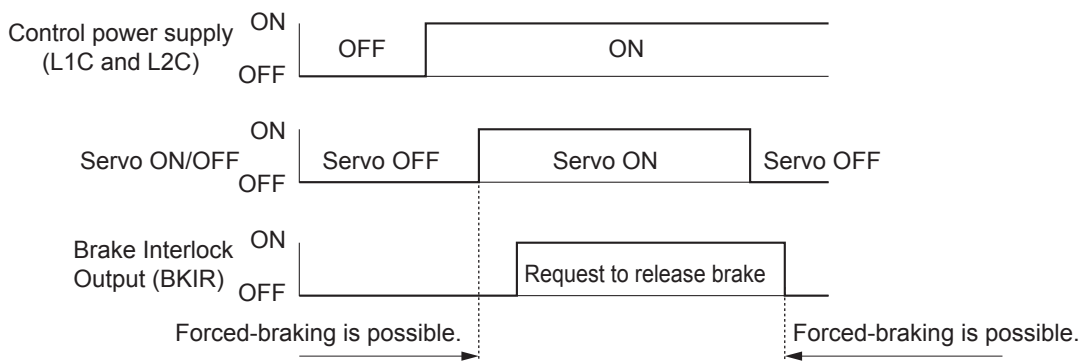

Servo ON/OFF Operation Timing When Motor Is Stopped

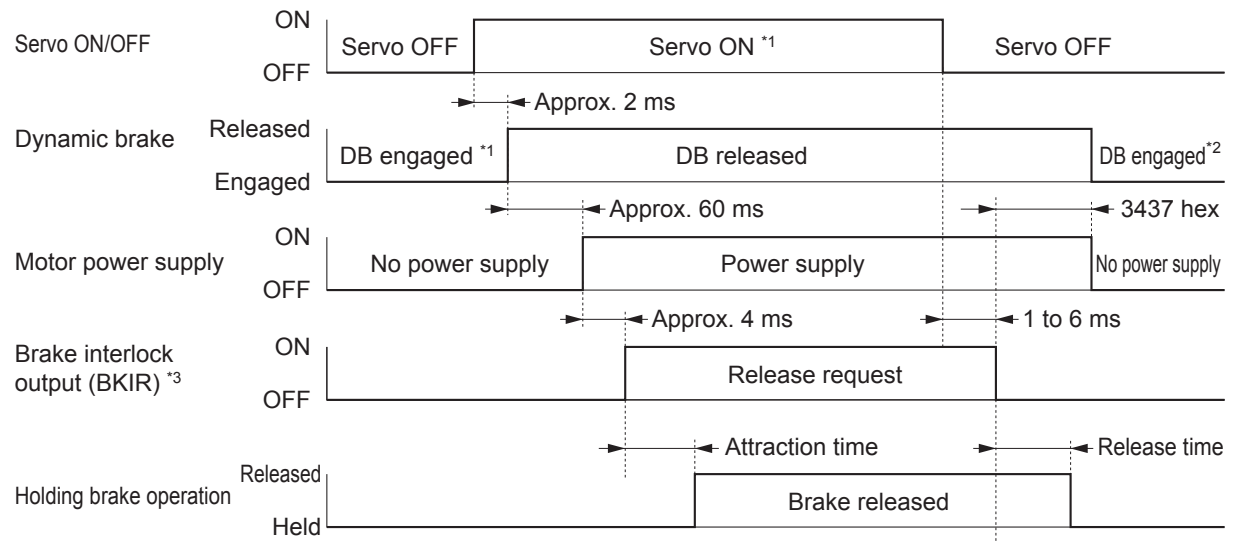

*1 The servo does not turn ON until the motor rotation speed drops to approx. 30 r/min or below.

*2 The operation of the dynamic brake when the servo is OFF depends on the setting of the Disable operation option code (605C hex).

*3 The Brake Interlock Output (BKIR) signal is output either when a release request command is received via Servo controls or when a release request command is received via EtherCAT communications. The above example shows when there is no brake release request from EtherCAT communications. The BKIR is assigned to the general-purpose output (CN1).

Note The brake application time and release time vary depending on the Servomotor brake. For details, refer to 3-3 *Servomotor Specifications* on page 3-36.

Servo ON/OFF Operation Timing When Motor Is Operating

Based on these operation timings, regenerative energy is produced if the motor rotation stops abnormally. Accordingly, repeated operation cannot be performed. Provide a wait time of at least 10 minutes for the motor to cool down.

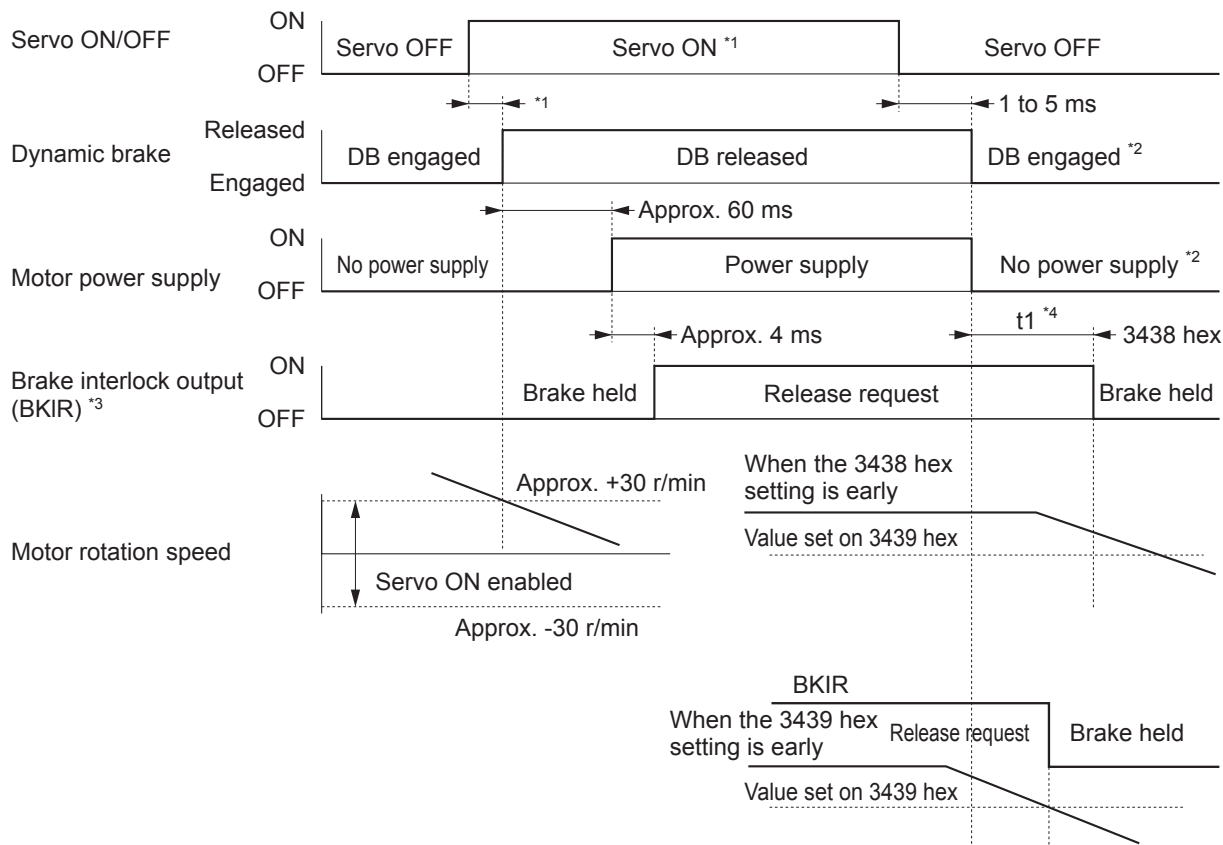

- *1 The servo does not turn ON until the motor rotation speed drops to approx. 30 r/min or below. If a Servo ON is commanded during motor rotation, the Command Warning (Warning No. B1 hex) will occur. The Servo ON command is ignored.
- *2 The operation of the dynamic brake when the servo is OFF depends on the setting of the Disable operation option code (605C hex).
- *3 The Brake Interlock output (BKIR) signal is output when a release request command is received from Servo controls or from EtherCAT communications. In the above example, there is no release request command from EtherCAT communications. The BKIR signal is assigned to the general-purpose output (CN1).
- *4 “t1” is the period until the value becomes lower than the set value on the Brake Timing During Operation (3438 hex) or the Brake Threshold Speed During Operation (3439 hex), whichever is shorter.

Note Even when the Servo ON Input is turned ON again while the motor is decelerating, the system does not enter the servo ON state until the motor stops.

Operation Timing When an Error Occurs (Servo ON)

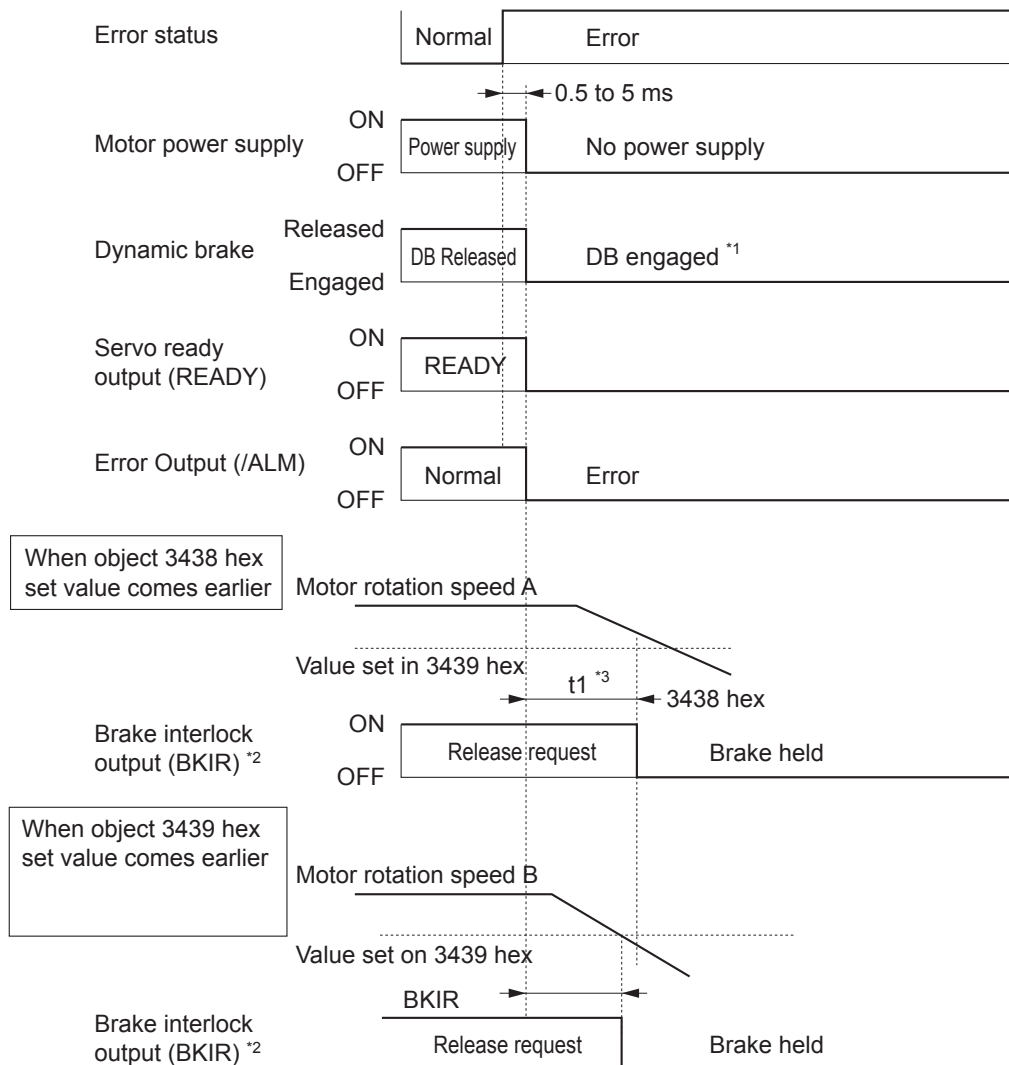

*1 The operation of the dynamic brake when there is an error depends on the setting of the Fault reaction option code (605E hex).

*2 The Brake Interlock Output (BKIR) signal is output either when a release request command is received via Servo controls or when a release request command is received via EtherCAT communications. The above example shows when there is no brake release request from EtherCAT communications. The BKIR signal is assigned to the general-purpose output (CN1).

*3 "t1" is the period until the value becomes lower than the set value on the Brake Timing During Operation (3438 hex) or the Brake Threshold Speed During Operation (3439 hex), whichever is shorter.

Note 1 Even when the servo ON input is turned ON again while the motor is decelerating, the system does not enter the servo ON state until the motor stops.

2 If the main circuit power supply turns OFF while the motor is operating, a phase loss error or main circuit voltage low error will occur, in which case this operation timing is applied.

Operation Timing When Resetting Errors

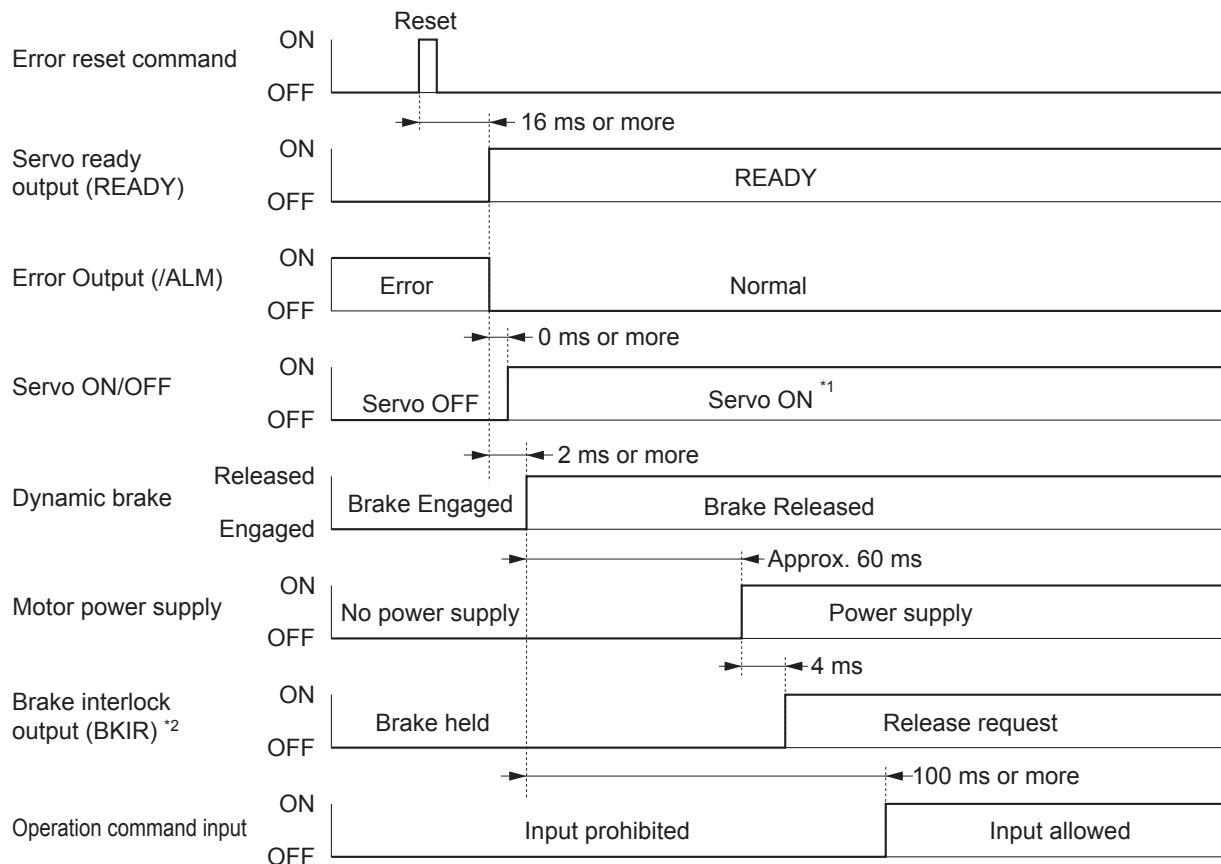

*1 The servo does not turn ON until the motor rotation speed drops to approx. 30 r/min or below.

*2 The Brake Interlock Output (BKIR) signal is output either when a release request command is received via Servo controls or when a release request command is received via EtherCAT communications. The above example shows when there is no brake release request from EtherCAT communications. The BKIR signal is assigned to the general-purpose output (CN1).

Note After the error has been reset, the system enters the servo OFF state (motor not energized). To turn ON the servo, send a servo ON command again after resetting the error, according to the above timing.

7-6 Electronic Gear Function

This function controls the position by using the value multiplied the position command entered on the Host Controller by the preset electronic gear ratio. The functions is used in the Position Control and Fully-closed Control modes. (This applies only when the communications cycle is 1, 2, or 4 ms.)

For communications cycles for which the electronic gear is not supported (250 or 500 μ s), a Function Setting Error (Error No. 93.4) will occur if the electronic gear is enabled.

When connected to an OMRON Machine Automation Controller NJ-series (Model: NJ501-1□00) or CJ1W-NC□81/□82 Position Control Unit, the electronic gear ratio is set in the Position Control Unit. Set the electronic gear ratio in the Servo Drive to 1:1.



Precautions for Correct Use

- The electronic gear function is not supported for unit version 2.0. For the Servo Drives with unit version 2.0, set the electronic gear ratio to 1.1.

7-6-1 Objects Requiring Settings

Index	Sub-index	Name	Explanation	Reference
6091 hex	01 hex	Motor revolutions *1	Set the numerator of the electronic gear ratio. If the set value is 0, the encoder resolution is automatically set as the numerator. *2 <ul style="list-style-type: none"> • 131072 for a 17-bit absolute encoder • 1048576 for a 20-bit incremental encoder 	page A-92
	02 hex	Shaft revolutions *1	Set the denominator of the electronic gear ratio.	

*1 The electronic gear ratio must be set between 1/1000 and 1000. If it is set outside the range, an Object Setting Error 1 (Error No. 93.0) will occur.

Whether the electronic gear is enabled is determined from the setting of the objects. If the gear ratio setting is 1:1, the electronic gear is disabled.

*2 If object 6091-01 hex is set to 0, the encoder resolution is set to the numerator during fully-closed control also.

Gear ratio Setting (6091-01 and 6091-02 Hex)

Motor revolutions (6091-01 hex)	Shaft revolutions (6091-02 hex)	Description
0	1 to 1073741824	<p>When the Motor revolutions (6091-01 hex) is 0, the processing changes with the set value of Shaft revolutions (6091-01 hex).</p> <div style="text-align: center;"> </div> <p>Position command = Encoder resolution / Shaft revolutions (6091-02 hex)</p>
1 to 1073741824		<p>When the Motor revolutions (6091-01 hex) is not 0, the processing changes with the set values of Motor revolutions (6091-01 hex) and Shaft revolutions (6091-02 hex).</p> <div style="text-align: center;"> </div> <p>Position command = Motor revolutions (6091-01 hex) / Shaft revolutions (6091-02 hex)</p>

*1 The encoder resolution is set as the numerator for fully-closed control.



Precautions for Correct Use

- To make the position command smoother after the electronic gear setting, adjust it by using the Position Command Filter Time Constant (3222 hex) or by the Position Command FIR Filter Time Constant (3818 hex).

7-6-2 Operation Example

The example uses a motor with a 20-bit encoder (1,048,576 pulses per rotation)

When the Motor Revolutions (6091-01 Hex) Is Set to 0

- If you set 6091-02 hex to 2,000, the operation is the same as the 2,000 (pulses/rotation) Servomotor.

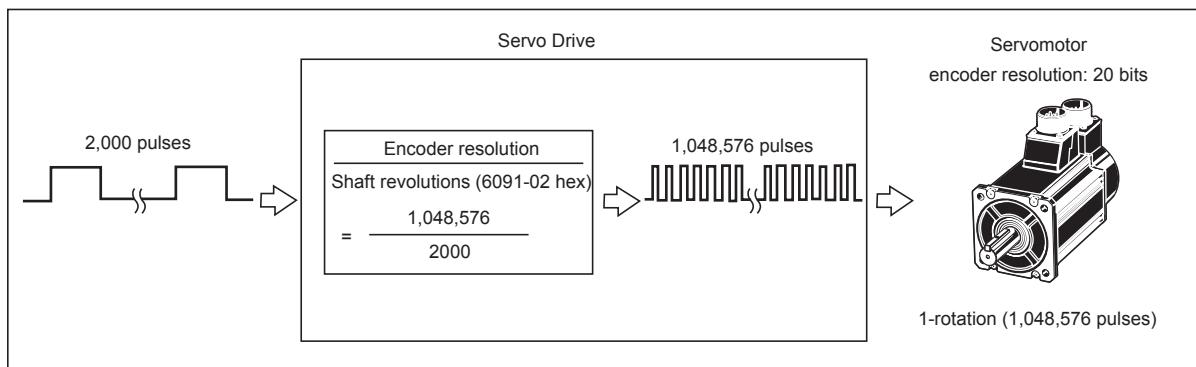

When the Motor Revolutions (6091-01 Hex) Is Set to a Value Other Than 0

- If you set 6091-01 hex and 6091-02 hex to 1,048,576 and 2,048, respectively, the operation is the same as a 2,048-pulses/rotation Servomotor.

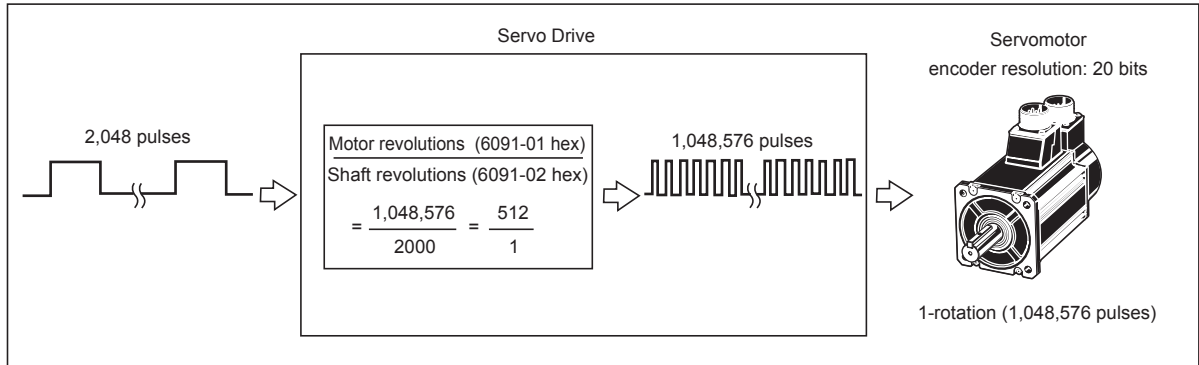

7-7 Torque Limit Switching

This function switches the torque limit according to the operation direction, and depending on the Forward External Torque Limit (PCL), the Reverse External Torque Limit (NCL), and the Forward/Reverse Torque Limit Input Commands from EtherCAT communications.

This function is used in the following conditions.

- When push-motion operation, such as pressing, is performed.
- When the torque at startup and during deceleration should be suppressed to protect the mechanical system, etc.

The Torque Limit Selection (3521 hex) is used to select a method to switch the torque limit.

7-7-1 Operating Conditions

The torque limit switching function works under the following conditions.

	Conditions
Operation mode	Position Control Mode, Speed Control Mode, Torque Control Mode, or Fully-closed Control Mode
Others	<ul style="list-style-type: none"> • Servo ON state • The factors other than control objects must be set correctly. This includes the torque limit. The motor must operate normally without any failures.

7-7-2 Objects Requiring Settings

Index	Name	Explanation	Reference
3521 hex	Torque Limit Selection	Select the torque limit based on the various objects and input signals.	page 9-45
60E0 hex	Positive torque limit value	Set the forward torque limit value.	page A-70
60E1 hex	Negative torque limit value	Set the reverse torque limit value.	page A-71
3525 hex	Forward External Torque Limit	Set the forward torque limit for a network signal.	page 9-46
3526 hex	Reverse External Torque Limit	Set the reverse torque limit for a network signal.	page 9-46

Torque Limit in Position, Speed, Torque, and Fully-Closed Controls

Set value	Position control/speed control/torque control/fully-closed control			
	Forward torque limit value ^{*1}		Reverse torque limit value ^{*2}	
	PCL ON	PCL OFF	NCL ON	NCL OFF
0,1	3013 hex			
2	3013 hex		3522 hex	
3	3522 hex	3013 hex	3522 hex	3013 hex
4	60E0 or 3013 hex ^{*3}		60E1 or 3522 hex ^{*4}	
5	60E0 or 3013 hex ^{*3}	3013 hex	60E1 or 3522 hex ^{*4}	3522 hex
6	3525 hex	60E0 or 3013 hex ^{*3}	3526 hex	60E1 or 3522 hex ^{*4}
7	3013 hex	3525 hex	3522 hex	3526 hex

*1 PCL ON is the state in which either the external input signal (PCL) or the EtherCAT communications torque control command (P-CL) is ON; PCL OFF is the state in which both of these are OFF.

*2 NCL ON is the state in which either the external input signal (NCL) or the EtherCAT communications torque control command (N-CL) is ON; NCL OFF is the state in which both of these are OFF.

*3 The smaller of 60E0 hex or 3013 hex is used.

*4 The smaller of 60E1 hex or 3522 hex is used.



Precautions for Correct Use

- For the torque limit parameters, the objects that are specified are different for an R88D-KN□□□-ECT-R Servo Drive. Refer to the *G5 AC Servomotors/Servo Drives User's Manual* (Cat. No. I573) for details on R88D-KN□□□-ECT-R objects.

Torque Limit Settings by Servomotors

- The torque limit setting range is between 0% and 300%. The default setting is 300%. This is not the case when a Servo Drive and a Servomotor are used in the following combinations.

Servo Drive	Applicable Servomotor	Maximum torque limit [%]
R88D-KN15□-ECT	R88M-K90010□	225
R88D-KN30□-ECT	R88M-K2K010□	250
R88D-KN50□-ECT	R88M-K3K010□	250
	R88M-K4K510□	263
R88D-KN75□-ECT	R88M-K6K010□	272
R88D-KN75H-ECT	R88M-K7K515T	265
R88D-KN75F-ECT	R88M-K7K515C	267
R88D-KN150□-ECT	R88M-K11K015□	265
	R88M-K15K015□	253

7-8 Soft Start

This function is used to control the rotation speed. It sets the acceleration and deceleration against the rotation speed command in the Servo Drive.

The function can be used for step rotation speed commands, and allows soft starts. The S-curve Acceleration and Deceleration function is used to reduce any impacts by acceleration changes.

7-8-1 Objects Requiring Settings

Index	Name	Description	Reference
3312 hex	Soft Start Acceleration Time	Sets the acceleration time for the rotation speed command input.	page 9-26
3313 hex	Soft Start Deceleration Time	Sets the deceleration time for the rotation speed command input.	page 9-26
3314 hex	S-curve Acceleration/Deceleration Time Setting	Sets the acceleration or deceleration processing S-curve time for the rotation speed command input.	page 9-27

7-8-2 Soft Start Acceleration or Deceleration Time

Set the time required for a step speed command to reach the maximum motor rotation speed into the Soft Start Acceleration Time (3312 hex). In the same manner, set the time required for the command to decrease the speed from the maximum motor rotation speed to 0 r/min into the Soft Start Deceleration Time (3313 hex).

The time taken for acceleration or deceleration is calculated by the following formula, where V_c [r/min] is the target rotation speed of the speed command.

$$\text{Acceleration Time [ms]} = V_c / \text{Maximum motor rotation speed} \times 3312 \text{ hex} \times 1 \text{ ms}$$

$$\text{Deceleration Time [ms]} = V_c / \text{Maximum motor rotation speed} \times 3313 \text{ hex} \times 1 \text{ ms}$$

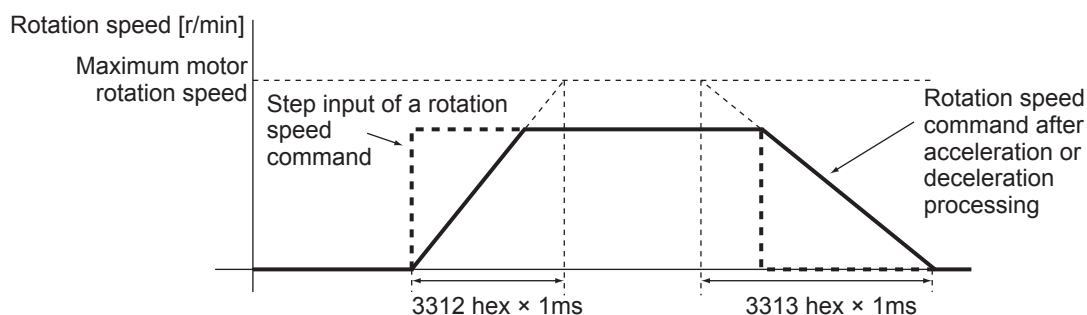

Precautions for Correct Use

- Do not set the Soft Start Acceleration Time and the Soft Start Deceleration Time when the position loop structure with a Host Controller is used.

7-8-3 S-curve Acceleration or Deceleration Time

The function sets the S-curve time for the acceleration and deceleration time set by the Soft Start Acceleration Time (3312 hex) and the Soft Start Deceleration Time (3313 hex). The S-curve time is a duration around an inflection point during acceleration and deceleration.

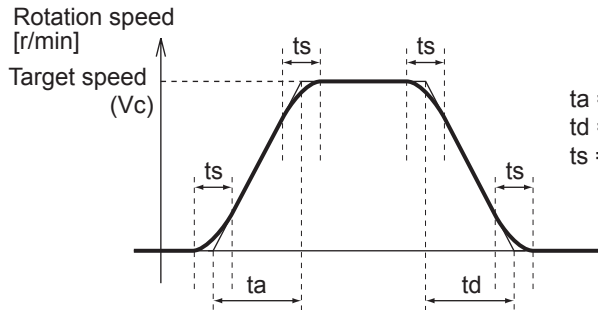

$$t_a = V_c / \text{Maximum motor rotation speed} \times 3312 \text{ hex} \times 1 \text{ ms}$$

$$t_d = V_c / \text{Maximum motor rotation speed} \times 3313 \text{ hex} \times 1 \text{ ms}$$

$$t_s = 3314 \text{ hex} \times 1 \text{ ms}$$

Note Be sure that t_s is smaller than the values obtained by the divisions of

$$\frac{t_a}{2} \text{ and } \frac{t_d}{2} .$$

7-9 Gain Switching Function

This function switches the position loop and speed loop gain.

Select enable or disable using Gain Switching Input Operating Mode Selection (3114 hex). Set the switching condition using the gain switching setting.

If the load inertia changes or you want to change the responsiveness depending on whether the motor is stopping or operating, you can perform optimal control by using gain switching.

The function is used when the realtime autotuning does not work effectively, such as:

- When the load inertia fluctuates in 200 ms or less.
- When the motor rotation speed does not exceed 500 r/min, or load torque does not exceed 50% of the rated torque.
- When an external force is constantly applied, as with a vertical axis.



Precautions for Correct Use

- When Gain 2 has been selected, realtime autotuning does not operate normally. If using the gain switching, set the Realtime Autotuning to “Disabled” (3002 hex = 0).
-

7-9-1 Objects Requiring Settings

Index	Name	Description	Reference
3002 hex	Realtime Autotuning Mode Selection	Set the operation mode for realtime autotuning. Realtime autotuning cannot be used if the gain switching function is being used.	page 9-3
3114 hex	Gain Switching Input Operating Mode Selection	Set whether to enable or disable the gain switching function.	page 9-11

Position Control Mode and Fully-closed Control Mode

3115 hex	Switching Mode in Position Control	Set the condition for switching between Gain 1 and Gain 2.	page 9-11
3116 hex	Gain Switching Delay Time in Position Control	Set the delay time for switching from the Gain 2 to Gain 1. (Unit: 0.1 ms)	page 9-13
3117 hex	Gain Switching Level in Position Control	Set the judgment level for switching between the Gain 1 and Gain 2.	page 9-13
3118 hex	Gain Switching Hysteresis in Position Control	Set the hysteresis width to be used for the judgment level set in Gain Switching Level (3117 hex).	page 9-13
3119 hex	Position Gain Switching Time	Set the time to change from one position gain to the other one. (Unit: 0.1 ms)	page 9-14

Speed Control Mode

3120 hex	Switching Mode in Speed Control	Set the condition for switching between gain 1 and gain 2.	page 9-15
3121 hex	Gain Switching Delay Time in Speed Control	Set the time to return from the gain 2 to gain 1. (Unit: 0.1 ms)	page 9-16
3122 hex	Gain Switching Level in Speed Control	Set the judgment level for switching between the gain 1 and gain 2.	page 9-16
3123 hex	Gain Switching Hysteresis in Speed Control	Set the hysteresis width to be provided in the judgment level set in Gain Switching Level in Speed Control (3122 hex).	page 9-17

Torque Control Mode

3124 hex	Switching Mode in Torque Control	Set the condition for switching between gain 1 and gain 2.	page 9-17
3125 hex	Gain Switching Delay Time in Torque Control	Set the time to return from the gain 2 to gain 1. (Unit: 0.1 ms)	page 9-18
3126 hex	Gain Switching Level in Torque Control	Set the judgment level for switching between the gain 1 and gain 2.	page 9-18
3127 hex	Gain Switching Hysteresis in Torque Control	Set the hysteresis width to be provided in the judgment level set in Gain Switching Level in Torque Control (3126 hex).	page 9-19

7-9-2 Gain Switching Based on the Control Mode

The settable switching conditions vary depending on the control mode used. Set the objects for each control mode.

Refer to *Chapter 9 Details on Servo Parameter Objects* for details on gain-related objects.

Position Control Mode and Fully-closed Control Mode

In the Position Control mode and Fully-closed Control Mode, operation varies as follows according to switching mode in Position Control (3115 hex).

Set value of 3115 hex	Description			
	Gain switching conditions	Gain Switching Delay Time in Position Control (3116 hex) ^{*1}	Gain Switching Level in Position Control (3117 hex)	Gain Switching Hysteresis in Position Control (3118 hex) ^{*2}
0	Always Gain 1 (3100 to 3104 hex).	Disabled	Disabled	Disabled
1	Always Gain 2 (3105 to 3109 hex).	Disabled	Disabled	Disabled
2	Gain switching command input via EtherCAT communications ^{*3}	Disabled	Disabled	Disabled
3	Command torque value (Refer to Figure A.)	Enabled	Enabled ^{*4} (%)	Enabled ^{*4} (%)
4	Always Gain 1 (3100 to 3104 hex).	Disabled	Disabled	Disabled
5	Command speed (Refer to Figure B.)	Enabled	Enabled (r/min)	Enabled (r/min)
6	Pulse position error (Refer to Figure C.)	Enabled	Enabled ^{*5} (pulses)	Enabled ^{*5} (pulses)
7	Whether there is a position command (Refer to Figure D.)	Enabled	Disabled	Disabled
9	Actual motor speed (Refer to Figure B.)	Enabled	Enabled (r/min)	Enabled (r/min)
10	Combination of whether there is a position command and actual motor speed (Refer to Figure E.)	Enabled	Enabled ^{*6} (r/min)	Enabled ^{*6} (r/min)

*1 The Gain Switching Delay Time in Position Control (3116 hex) becomes effective when the gain is switched from 2 to 1.

*2 The Gain Switching Hysteresis in Position Control (3118 hex) is defined in the drawing below.

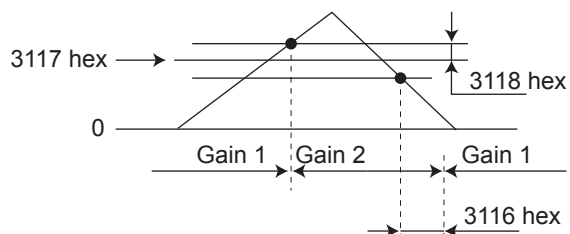

If object 3117 hex is less than object 3118 hex, object 3117 hex will automatically be set to the same value as object 3118 hex.

*3 When the Gain Switching command of EtherCAT communications (G-SEL) is 0, the gain switches to gain 1. When the command is 1, the gain switches to gain 2.

*4 Set the percentage of the rated torque.
Example: To set 10% of the rated torque, set the set value would be 10.

*5 The position error is set according to the encoder resolution (i.e., pulses) for position control and according to the external encoder resolution (i.e., pulses) for fully-closed control.

*6 When the set value is 10, the meanings of the Gain Switching Delay Time in Position Control, the Gain Switching Level in Position Control, and the Gain Switching Hysteresis in Position Control differ from the normal case. (Refer to Figure E.)

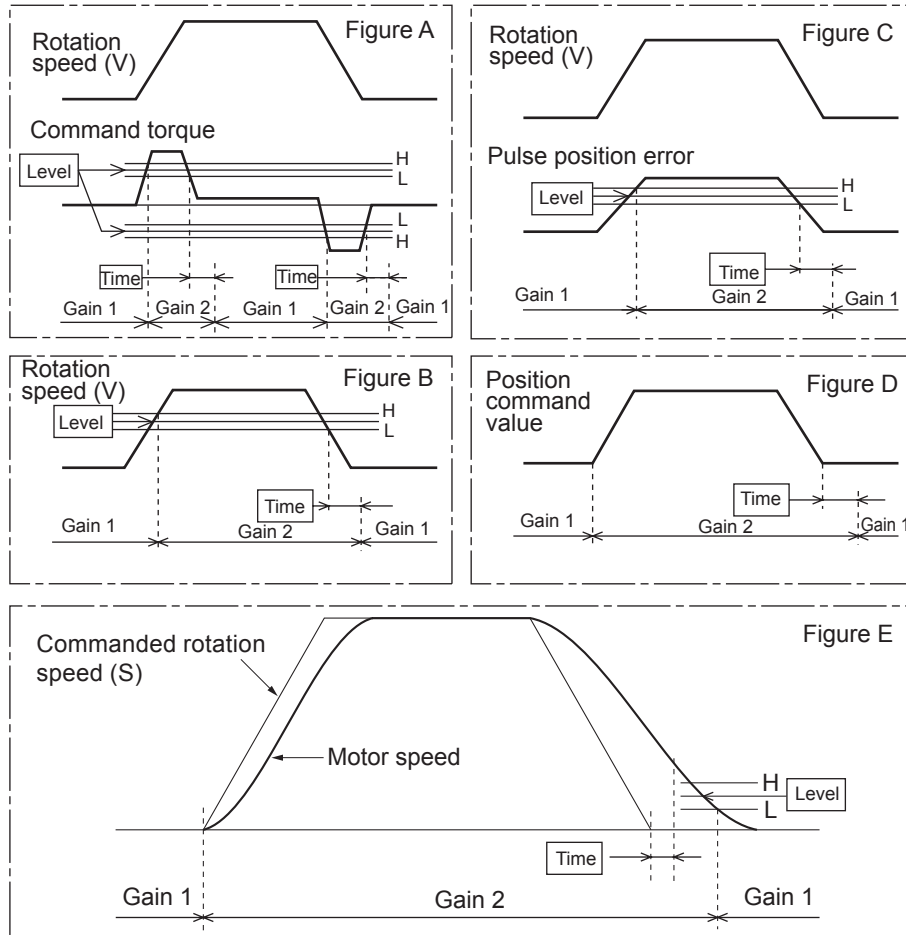

Speed Control Mode

In the Speed Control Mode, it varies as follows according to Switching Mode in Speed Control (3120 hex).

3120 hex set value	Description			
	Gain switching conditions	Gain Switching Delay Time in Speed Control (3121 hex) ^{*1}	Gain Switching Level in Speed Control (3122 hex)	Gain Switching Hysteresis in Speed Control (3123 hex) ^{*2}
0	Always the Gain 1 (3100 to 3104 hex).	Disabled	Disabled	Disabled
1	Always the Gain 2 (3105 to 3109 hex).	Disabled	Disabled	Disabled
2	Gain switching command input via EtherCAT communications ^{*3}	Disabled	Disabled	Disabled
3	Torque command variation (Refer to Figure A.)	Enabled	Enabled ^{*4} (0.05%)	Enabled ^{*4} (0.05%)
4	Speed command change amount (Refer to Figure B.)	Enabled	Enabled ^{*5} (10r/min/s)	Enabled ^{*5} (10r/min/s)
5	Speed command (Refer to Figure C.)	Enabled	Enabled (r/min)	Enabled (r/min)

*1 The Gain Switching Delay Time in Speed Control (3121 hex) becomes effective when the gain is switched from 2 to 1.

*2 The Gain Switching Hysteresis in Speed Control (3123 hex) is defined in the drawing below.

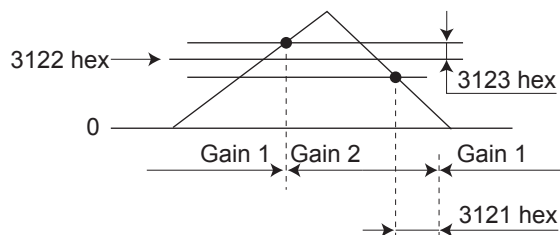

*3 When the Gain switching command of EtherCAT communications (G-SEL) is 0, the gain switches to Gain 1. When the command is 1, the gain switches to Gain 2.

*4 The variation means the change amount in a millisecond (ms).

E.g. The set value is 200 when the condition is a 10% change in torque in 1 millisecond.

- *5 When the set value is 10, meanings of the Gain Switching Delay Time in Speed Control (3121 hex), the Gain Switching Level in Speed Control (3122 hex), and the Gain Switching Hysteresis in Speed Control (3123 hex) differ from the normal case. (Refer to Figure D.)

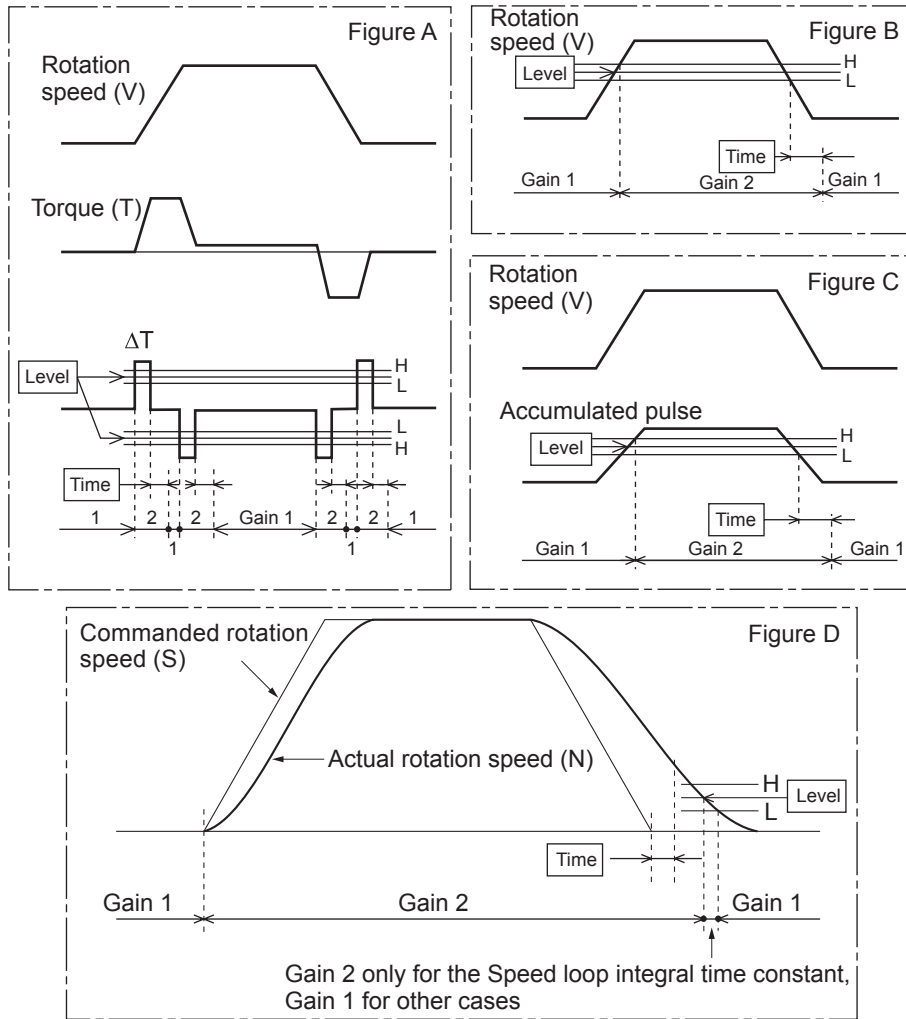

Torque Control Mode

In the Torque Control Mode, it varies as follows according to Switching Mode in Torque Control (3124 hex).

3124 hex set value	Description			
	Gain switching conditions	Gain Switching Delay Time in Torque Control (3125 hex) ^{*1}	Gain Switching Level in Torque Control (3126 hex)	Gain Switching Hysteresis in Torque Control (3127 hex) ^{*2}
0	Always Gain 1 (3100 to 3104 hex).	Disabled	Disabled	Disabled
1	Always Gain 2 (3105 to 3109 hex).	Disabled	Disabled	Disabled
2	Gain switching command input via EtherCAT communications ^{*3}	Disabled	Disabled	Disabled
3	Torque command change amount (Refer to Figure A.)	Enabled	Enabled ^{*4} (0.05%)	Enabled ^{*4} (0.05%)

*1 The Gain Switching Delay Time in Torque Control (3125 hex) becomes effective when the gain is switched from 2 to 1.

*2 The Gain Switching Hysteresis in Torque Control (3127 hex) is defined in the drawing below.

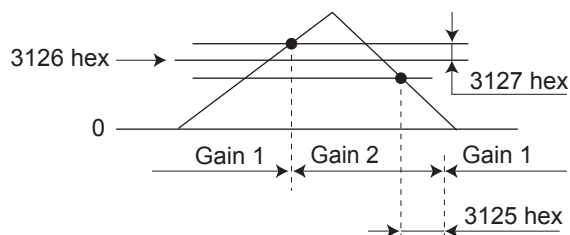

*3 When the Gain switching command of EtherCAT communications (G-SEL) is 0, the gain switches to Gain 1. When the command is 1, the gain switches to Gain 2.

*4 The variation means the change amount in a millisecond (ms).
E.g. The set value is 200 when the condition is a 10% change in torque in 1 millisecond.

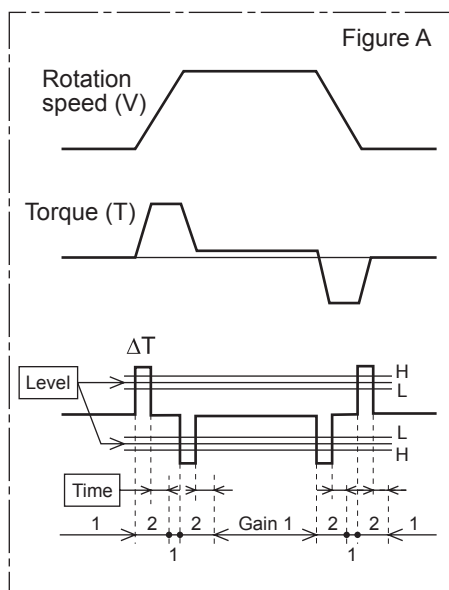

7-9-3 Diagrams of Gain Switching Setting

Switching between Gain 1 (3100 to 3104 hex) and Gain 2 (3105 to 3109 hex) occurs at the following timing. For the position loop gain, switching occurs based on the setting of 3119 hex.

The details of the gain switching settings vary depending on the control mode used. For the details of settings available in each mode, refer to *Gain Switching Based on the Control Mode* on page 7-30.

Gain Switching Mode = 2: Gain Switching (GSEL)

Instant switching occurs when a gain switching command is issued from the network.

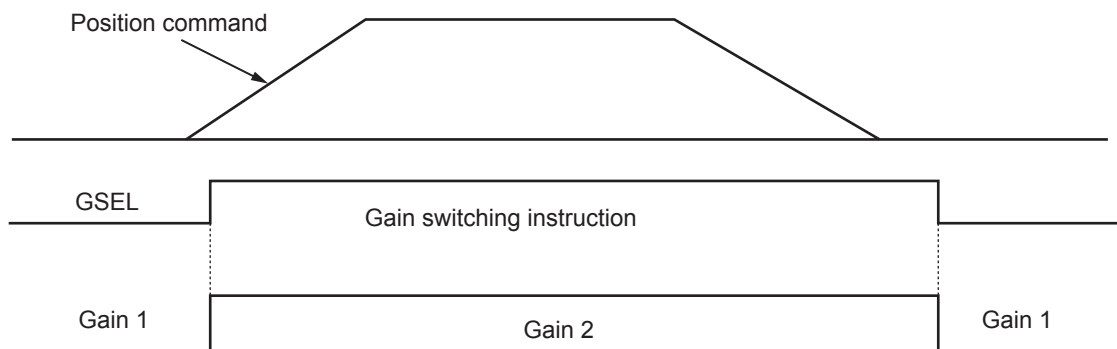

Gain Switching Mode = 3: Switching by Command Torque Value

If the absolute value of the command torque exceeds the sum of the Gain Switching Level in Position Control (3117 hex) plus the Gain Switching Hysteresis in Position Control (3118 hex), the gain switches to gain 2.

If the absolute value of the command torque exceeds the difference of the Gain Switching Level in Position Control (3117 hex) minus the Gain Switching Hysteresis in Position Control (3118 hex) for the time specified in the Gain Switching Delay Time in Position Control (3116 hex), the gain switches back to gain 1.

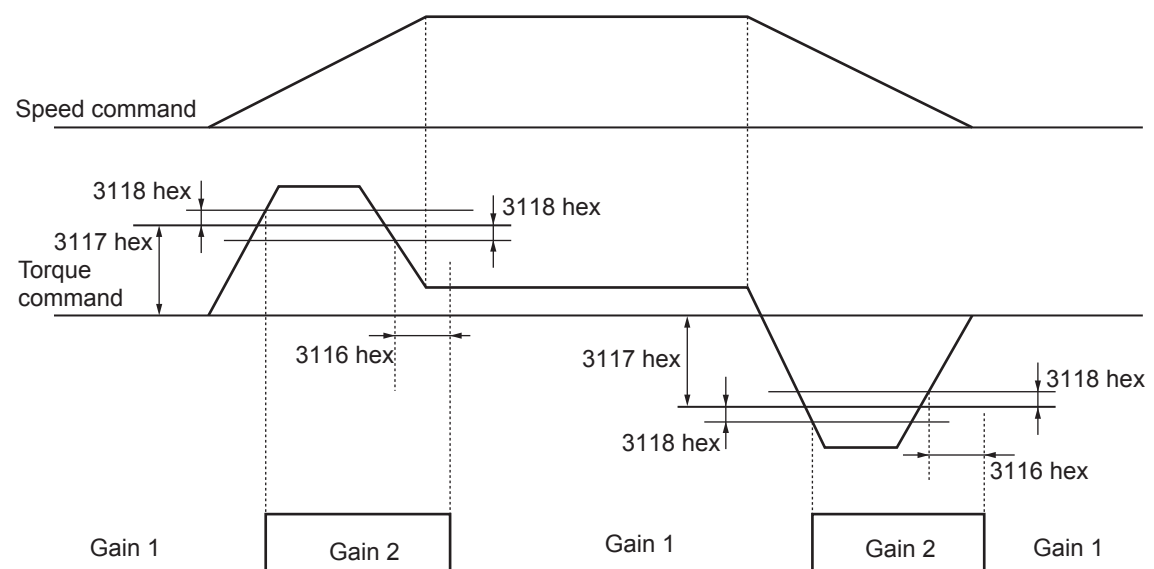

Gain Switching Mode = 5 or 9: Switching by Speed Command or Actual Motor Speed

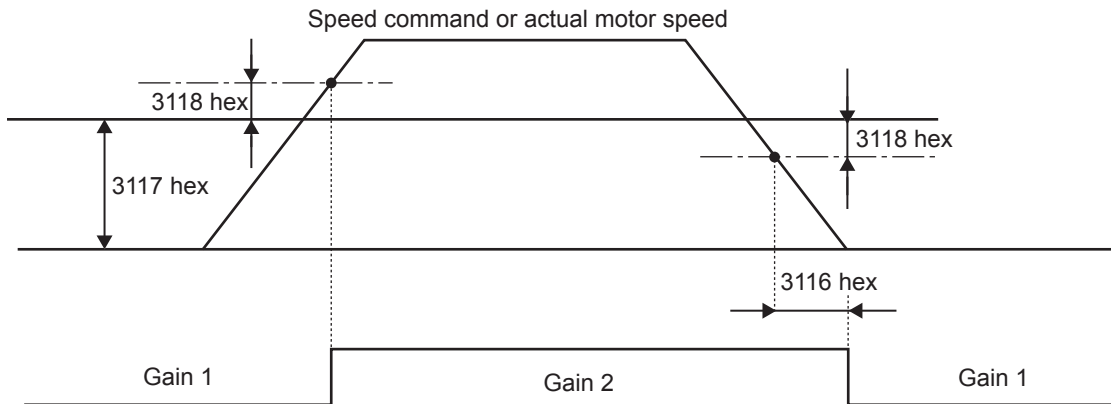

Note The “speed command” is the Motor Control Effort (401A hex) [r/min].

Gain Switching Mode = 6: Switching by Pulse Position Error

The gain is switched according to the pulse position error [encoder pulses/external encoder pulses].

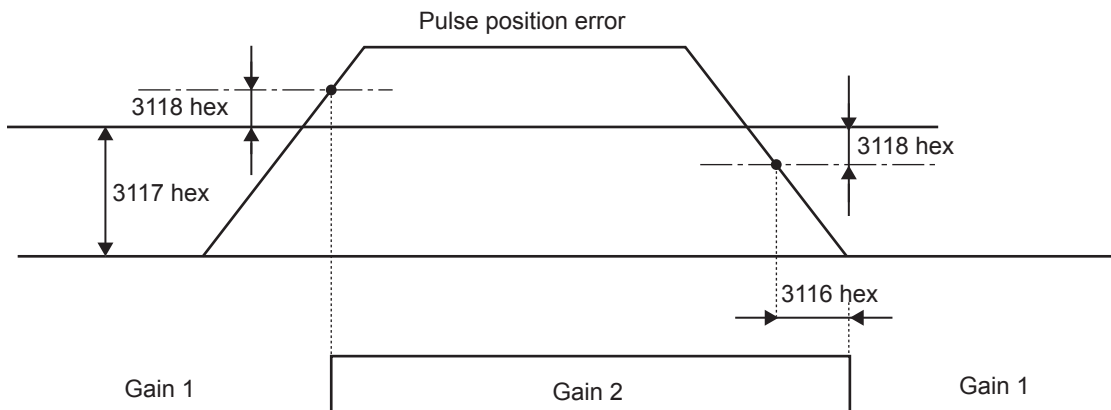

Gain Switching Mode = 7: Switching by Whether There Is a Position Command

The gain is switched according to whether there is a position command.

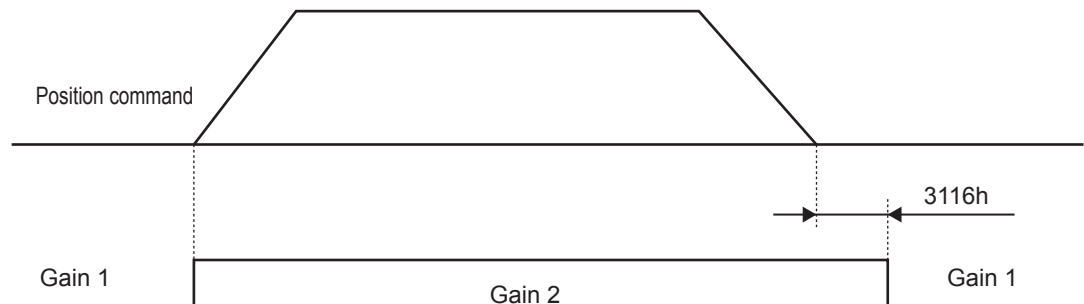

Note Whether there is a position command is determined by changes in the Target position (607A hex).

Gain Switching Mode = 10: Switching by Combination of Whether There Is a Position Command and Actual Motor Speed

Switching to the gain 2 occurs when a position command is received.

If there is no position command but the absolute value of the actual motor speed remains less than the difference of the Gain Switching Level in Position Control (3117 hex) minus the Gain Switching Hysteresis in Position Control (3118 hex) [r/min] for the time specified in the Gain Switching Delay Time in Position Control (3116 hex), the gain switches to gain 1.

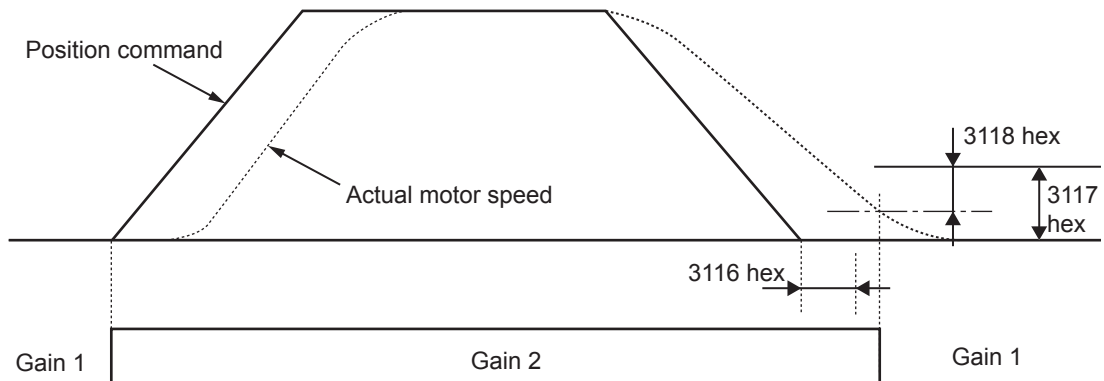

Note Whether there is a position command is determined by changes in the Target position (607A hex).

7-9-4 Position Gain Switching Time (3119 Hex)

Torque fluctuations or vibration will occur if the position loop gain is changed too quickly during position control or fully-closed control.

To suppress these, set a Position Gain Switching Time (3119 hex).

By setting the Position Gain Switching Time (3119 hex), the gain will be switched gradually when there is a large change in the position loop gain.

If there is a large difference between Position Loop Gain 1 (3100 hex) and Position Loop Gain 2 (3105 hex), set the Position Gain Switching Time (3119 hex).

When the position loop gain increases, the gain changes in the set time.

● Position Loop Gain 1 < Position Loop Gain 2

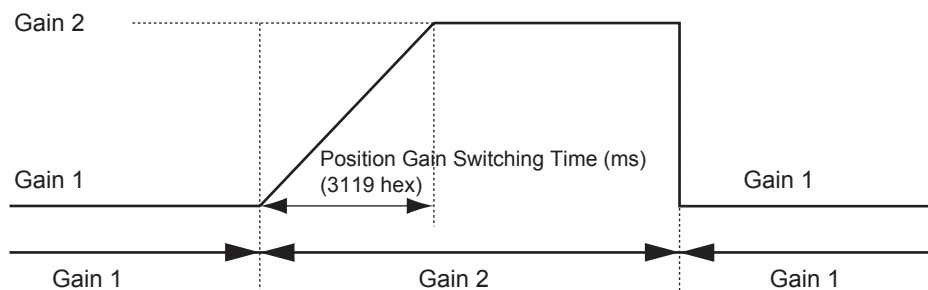

Precautions for Correct Use

When the position loop gain is switched to a smaller value (e.g., when switching from gain 2 to gain 1 in the above figure), Position Gain Switching Time (3119 hex) is ignored and the gain is switched immediately.

7-10 Gain Switching 3 Function

This function adds a new setting (gain 3) to the gain switching function of the Gain Switching Input Operating Mode Selection (3114 hex).

The positioning time can be reduced by keeping the gain immediately before the stop at a higher level for a certain period of time.

7-10-1 Operating Conditions

You can use the gain 3 switching function in the following situations for position control or fully-closed control.

	Conditions
Operating mode	Position Control Mode or Fully-closed Control Mode
Others	<ul style="list-style-type: none"> Servo ON state. The factors other than control parameters must be set correctly. This includes the torque limit. The motor must operate normally without any failures.

7-10-2 Objects Requiring Settings

Index	Name	Explanation	Reference
3605 hex	Gain 3 Effective Time	Set effective time of gain 3.	page 9-47
3606 hex	Gain 3 Ratio Setting	Set gain 3 as a multiple of gain 1.	page 9-47

7-10-3 Operation Example

When the conventional gain switching function works correctly, set the time to use Gain 3 in Gain 3 Effective Time (3605 hex), and the magnification of Gain 3 against Gain 1 in the Gain 3 Ratio Setting (3606 hex).

Operation Timings of Gain 1, 2 and 3

When the Switching Mode in Position Control (3115 hex) is set to 7, i.e., when the command pulses are received as the switching condition, the operation will be as shown below:

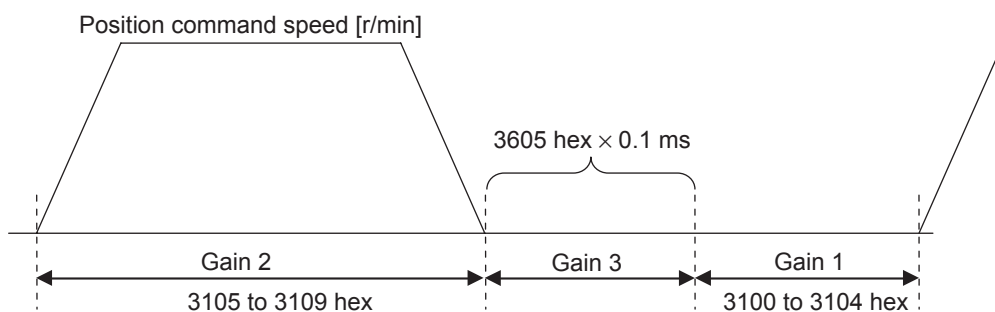

Gain 3 region
 Position loop gain = $3100 \times 3606 \text{ hex} / 100$
 Speed loop gain = $3101 \times 3606 \text{ hex} / 100$

The gain 1 values are used for the speed loop integral time constant, speed feedback filter time constant, and torque command filter time constant.



Precautions for Correct Use

- If gain 3 is not used, set the Gain 3 Effective Time (3605 hex) to 0 and the Gain 3 Ratio Setting (3606 hex) to 100.
 - In the gain 3 region, only the position loop gain and the speed loop gain are treated as gain 3, and the gain 1 setting is applied for all other gains.
 - If the gain 2 switching condition is established in the gain 3 region, operation switches to gain 2.
 - If gain 2 is switching to gain 3, the Position Gain Switching Time (3119 hex) is enabled.
 - There is a gain 3 region even when gain 2 is switched to gain 1 due to an object change and so forth.
-

7-11 Touch Probe Function (Latch Function)

The latch function latches the position actual value when an external latch input signal or the encoder's phase-Z signal turns ON. G5-series Servo Drives can latch two positions.

7-11-1 Related Objects

Index	Name	Description
60B8 hex	Touch probe function	Controls the latch function.
60B9 hex	Touch probe status	Gives the state of latches 1 and 2.
60BA hex	Touch probe pos1 pos value	Latch position of latch 1.
60BC hex	Touch probe pos2 pos value	Latch position of latch 2.
3404 hex	Input Signal Selection 5	Set the function for general-purpose input 5 (IN5).
3405 hex	Input Signal Selection 6	Set the function for general-purpose input 6 (IN6).
3406 hex	Input Signal Selection 7	Set the function for general-purpose input 7 (IN7).
3758 hex	Touch Probe Trigger Selection	Select the trigger signals for latch 1 and 2.

7-11-2 Trigger Signal Settings

The latch trigger can be selected from general-purpose inputs 5 to 7 or the encoder's phase-Z signal. The functions of general-purpose signals 5 to 7 from the control I/O connector are set with the Input Signal Selection 5 to 7 (3404 to 3406 hex). External latch input signals used by Latches 1 and 2 are set with the Touch Probe Trigger Selection (3758 hex).

Bits 2 and 10 of the Touch probe function (60B8 hex) are used to specify whether to latch with an external signal or the phase-Z signal.

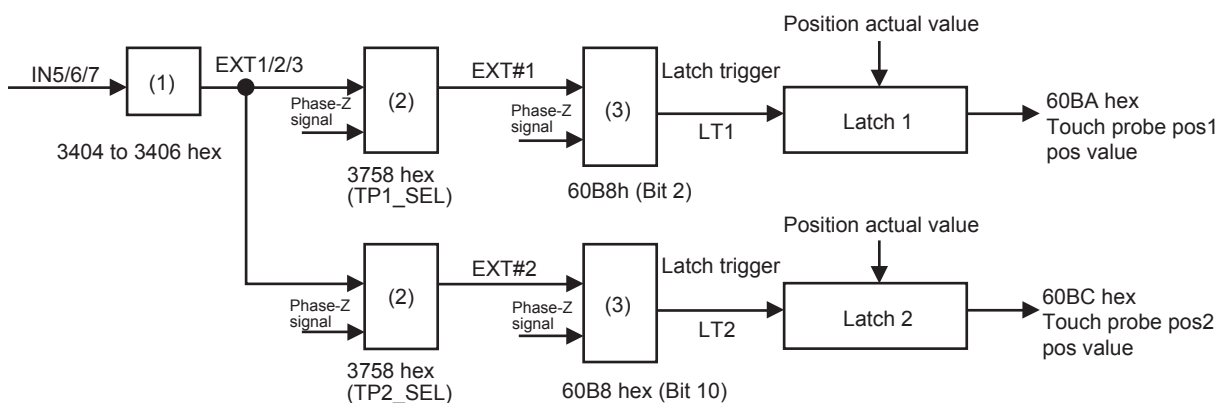

General-purpose Input Assignment in (1)

Signal	Index	Assignment
IN5	3404 hex	Select either EXT1, EXT2, or EXT3.
IN6	3405 hex	Select either EXT1, EXT2, or EXT3.
IN7	3406 hex	Select either EXT1, EXT2, or EXT3.

*1 The same function cannot be assigned more than once.

Touch Probe Trigger Selection (3758 hex) in (2)

Latch 1			Latch 2		
TP1_SEL		EXT#1	TP2_SEL		EXT#2
Bit 0	Bit 1		Bit 8	Bit 9	
0	0	EXT1	0	0	EXT1
1	0	EXT2	1	0	EXT2
0	1	EXT3	0	1	EXT3
1	1	Phase-Z signal	1	1	Phase-Z signal

Touch probe function (60B8 hex) in (3)

Bit 2	LT1	Bit 10	LT2
0	EXT#1	0	EXT#2
1	Phase-Z signal	1	Phase-Z signal

7-11-3 Operation Sequences

Trigger first event (60B8 Hex Bit 1/9 = 0: Trigger first event)

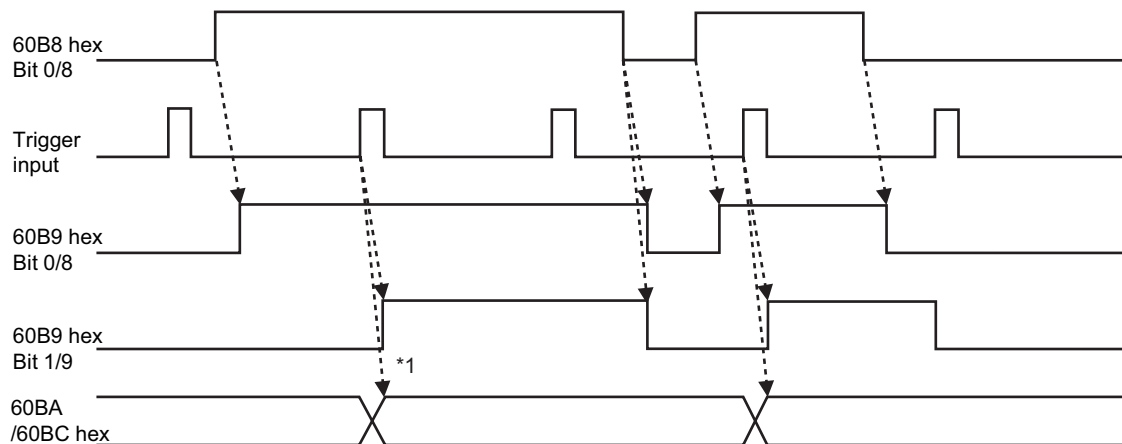

*1 The delay time is several tens of microseconds between the trigger input and position latch. This value is a reference value. Design the operation with a margin.

Continuous (60B8 Hex Bit 1/9 = 1: Continuous)

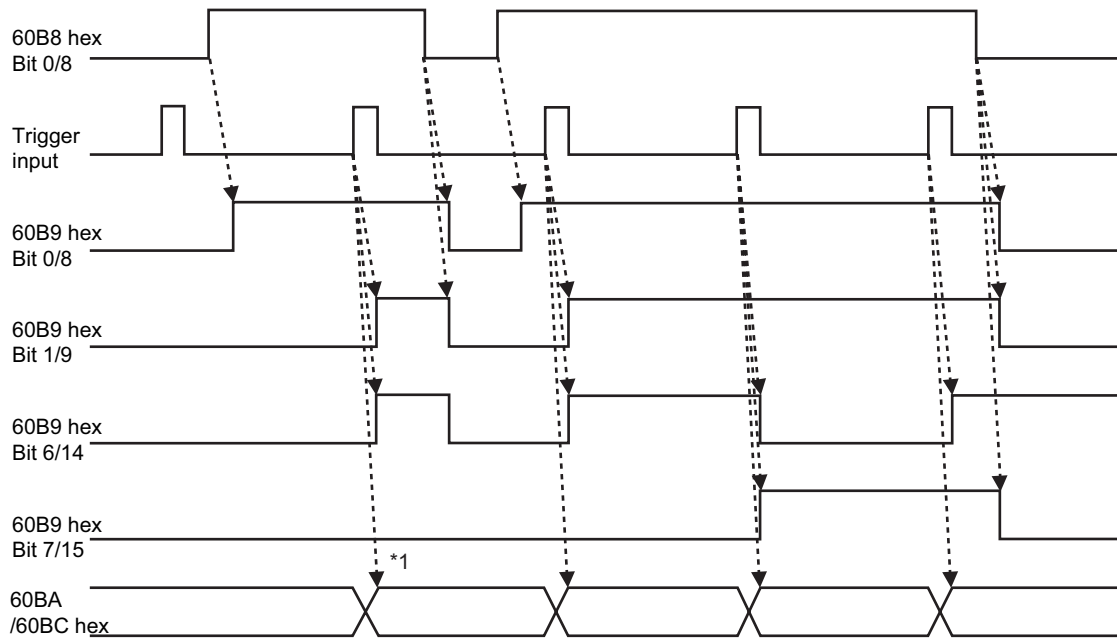

*1 The delay time is several tens of microseconds between the trigger input and position latch. This value is a reference value. Design the operation with a margin.



Safety Function

This function stops the Servomotor based on a signal from a safety controller or safety sensor. An outline of the function is given together with operation and connection examples.

8-1 Safe Torque OFF Function	8-2
8-1-1 I/O Signal Specifications	8-3
8-2 Operation Example	8-5
8-3 Connection Examples	8-7

8-1 Safe Torque OFF Function

The safe torque OFF function (hereinafter referred to as STO according to IEC 61800-5-2) is used to cut off the motor current and stop the motor through the input signals from a safety device, such as a safety controller or safety sensor, that is connected to the safety connector (CN8).

When the STO function is operating, the Servo Drive turns OFF the servo ready completed output (READY) to go into the safety status.

- The PFH value is 2.30×10^{-8} .



Precautions for Safe Use

- When using the STO function, be sure to execute a risk assessment of the equipment to confirm that the system safety requirements are met.
 - There are the following risks even when the STO function is operating. Be sure to take safety into account as part of the risk assessment.
 - The motor runs if an external force is present (e.g., force of gravity on a vertical axis). If holding is required, implement appropriate measures, such as providing external brakes. The brakes for a Servo Drive with brakes are used for holding only, and cannot be used for control.
 - Even if there is no external force, when the Fault reaction option code (605E hex) is set to free-run with the dynamic brake disabled, the motor uses free-run stopping and the stop distance is long.
 - In case of internal failure of components, the motor may operate in the range of up to 180 degrees of electrical angle.
 - The power supply to the motor is cut off by the STO function, but the power supply to the Servo Drive will not be cut off nor electrically isolated. For Servo Drive maintenance, cut off the power supply to the Servo Drive through another means.
 - Do not use the EDM output for any purpose other than the failure monitoring function. The EDM output signal is not a safety output.
 - Be sure to check the wiring when installing. Especially check the following:
 - The wiring is not short-circuited or disconnected.
 - The polarity of EDM circuit is not reversed.
 - SF1, SF2 and EDM operate properly.
 - The system with incorrect wiring may damage the safety function.
 - The dynamic brake and external brake release signal outputs are not safety-related parts. Make sure to design the equipment not to be dangerous even if the external brake release fails during the STO status.
 - When using the STO function, connect equipment that meets the safety standards.
-

8-1-1 I/O Signal Specifications

Safety Input Signals

There are 2 safety input circuits to operate the STO function.

Signal name	Symbol	Pin number	Description	Control mode			
				Position	Speed	Torque	Fully-closed
Safety input 1	SF+	CN8-4	• The upper arm drive signal of the power transistor inside the Servo Drive is cut off.	√	√	√	√
	SF-	CN8-3		√	√	√	√
Safety input 2	SF2+	CN8-6	• The lower arm drive signal of the power transistor inside the Servo Drive is cut off.	√	√	√	√
	SF2-	CN8-5		√	√	√	√

- When safety input 1 or 2 turns OFF, the STO function will start operating within 5 ms of the input, and the motor output torque will be reduced to 0.
- Connect the equipment so that the safety input circuit is turned OFF to operate the STO function.
- Set the operation when the safety input turns OFF in the Fault reaction option code (605E hex).



Precautions for Correct Use

- L pulses for self-diagnosis of safety equipment

When you are connecting a safety device, such as a safety controller or a safety sensor, the safety output signal of the device may include L pulses for self-diagnosis. To avoid malfunction due to the L pulses for self-diagnosis, a filter that removes the L pulses is built into the safety input circuit. If the OFF time of the safety input signal is 1 ms or less, the safety input circuit does not recognize it as OFF. To make sure that OFF is recognized, maintain the OFF status of safety input signal for at least 5 ms.

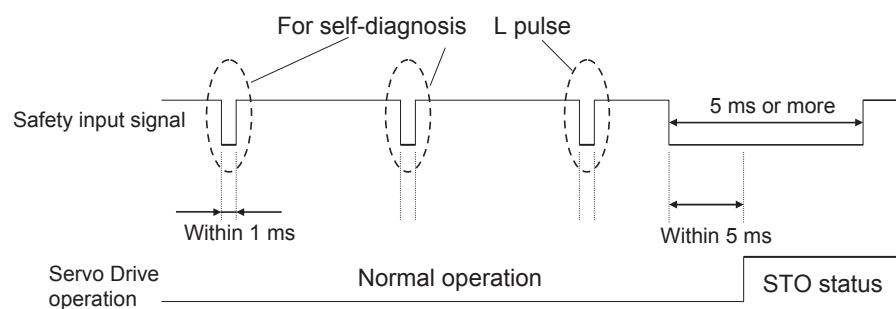

External Device Monitor (EDM) Output Signal

This is a monitor output signal that is used to monitor the status of safety input signals using an external device. Connect a safety device, such as a safety controller or a safety sensor. Connect the EDM output signal to the monitoring terminal on a safety device.

Signal name	Symbol	Pin number	Description	Control mode			
				Position	Speed	Torque	Fully-closed
EDM output	EDM+	CN8-8	<ul style="list-style-type: none"> Monitor signal is output to detect malfunctioning of the safety function. * This is not a safety output. 	√	√	√	√
	EDM-	CN8-7		√	√	√	√

● Relationship between Safety Input Signals and EDM Output Signal

Normally when both safety inputs 1 and 2 are OFF, i.e., when the STO function is activated for both safety input circuits, the EDM output is ON.

You can detect a failure of the safety input circuit and the EDM output circuit by monitoring all of the following 4 signal states using an external device.

These are the two cases of errors:

- Both safety inputs 1 and 2 are OFF, but the EDM output circuit signal does not turn ON.
- Either or both safety inputs 1 and 2 are ON, but the EDM output circuit signal is ON.

Signal name	Symbol	Signal status			
Safety input 1	SF1	ON	ON	OFF	OFF
Safety input 2	SF2	ON	OFF	ON	OFF
EDM output	EDM	OFF	OFF	OFF	ON

- The maximum delay time is 6 ms after the safety input signal is input until the EDM output signal is output.

8-2 Operation Example

● Operation Timings to a Safety Status

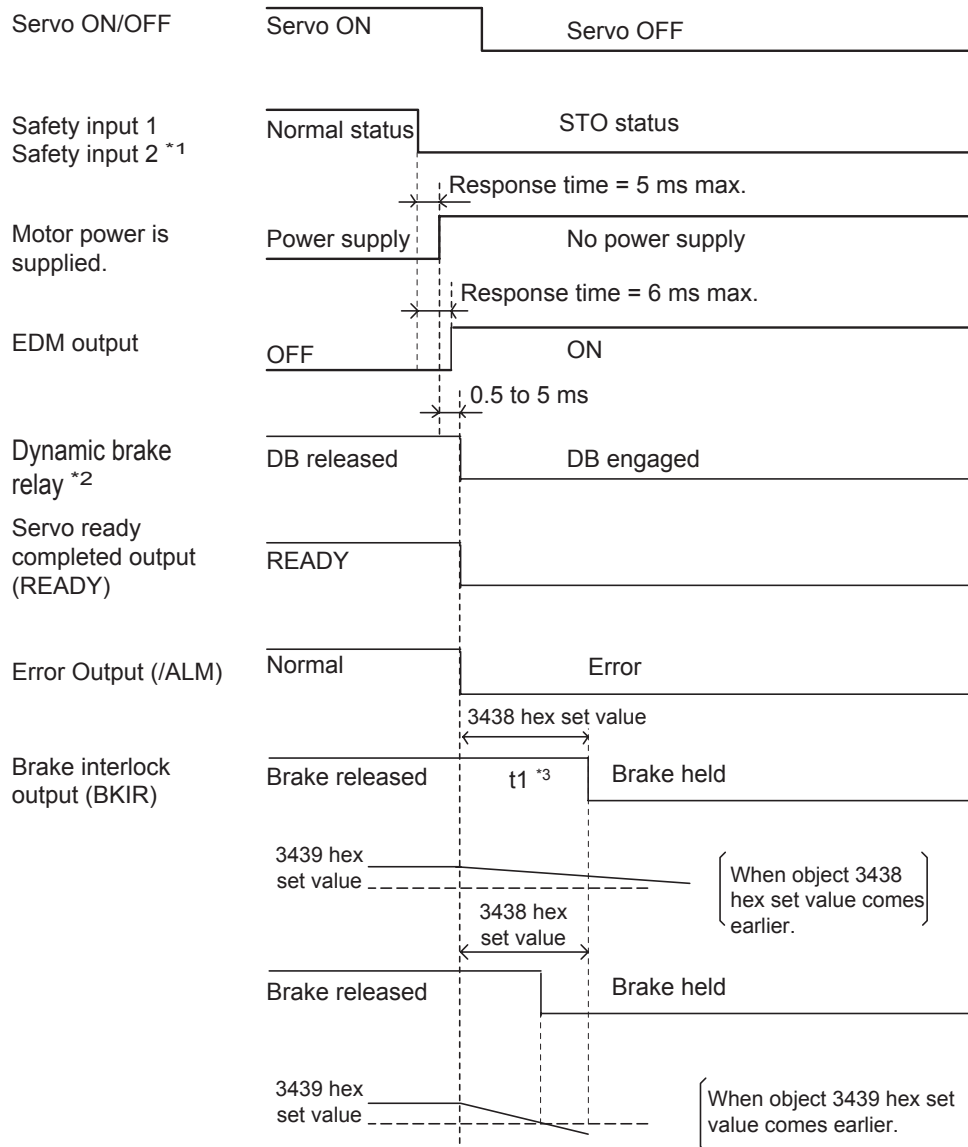

*1 STO status is entered when either safety input 1 or 2 turns OFF

*2 The dynamic brake operates according to the setting of the Fault reaction option code (605E hex).

*3 t1 is the set value of the Brake Timing During Operation (3438 hex), or the time needed for the motor rotation speed to drop to or below the Brake Threshold Speed During Operation (3439 hex), whichever occurs first.

● **Timing of Return from Safety Status**

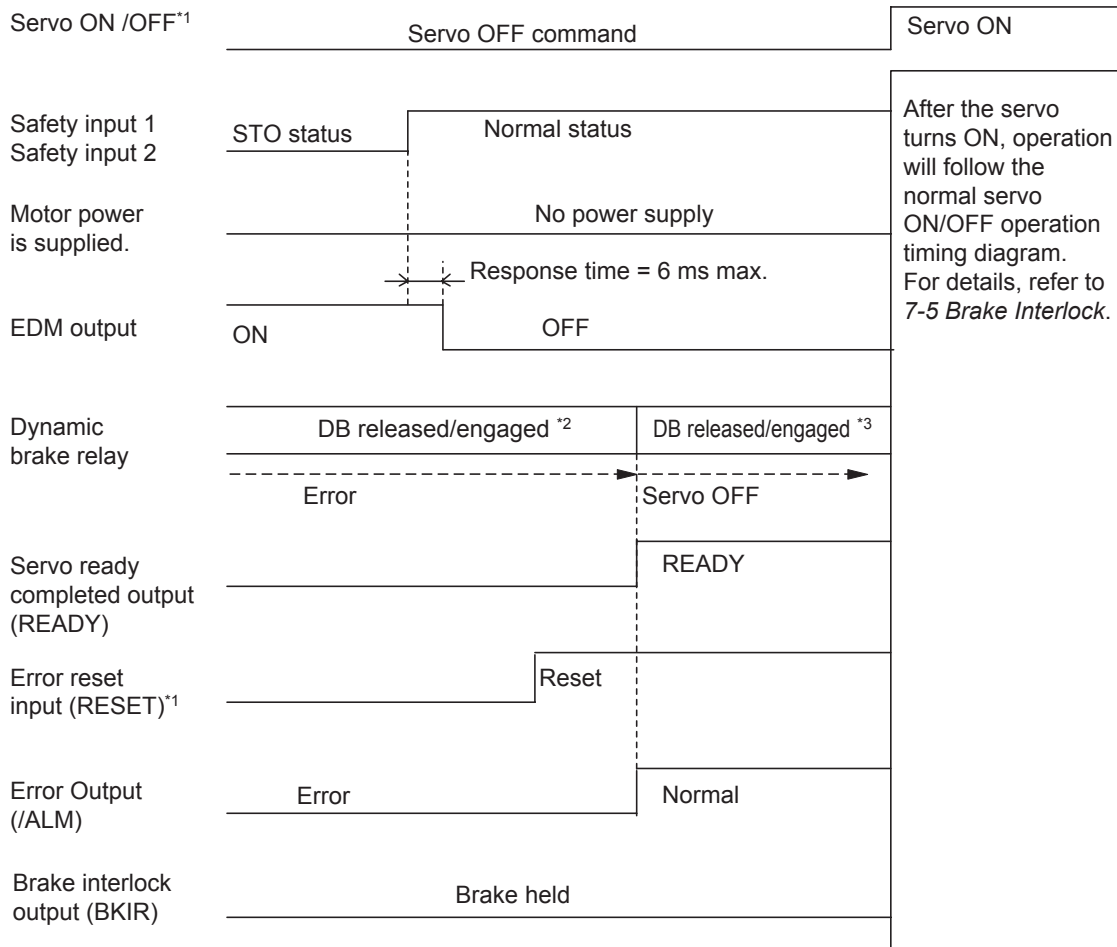

- *1 Make sure that servo ON input is turned OFF when you return the input signals of safety inputs 1 and 2 to ON. If an error exists in this state, be sure to clear the error when both safety inputs 1 and 2 have returned to ON state. Also, depending on the execution timing, an Other Error (Error No. 99.9) may occur. If this error (Error No. 99.9) occurs, turn OFF and then ON the power again.
- *2 An error exists in this state. The dynamic brake operates according to the Fault reaction option code (605E hex).
- *3 An error exists in this state. The dynamic brake operates according to the Disable operation option code (605C hex).

8-3 Connection Examples

Connection with a Safety Controller

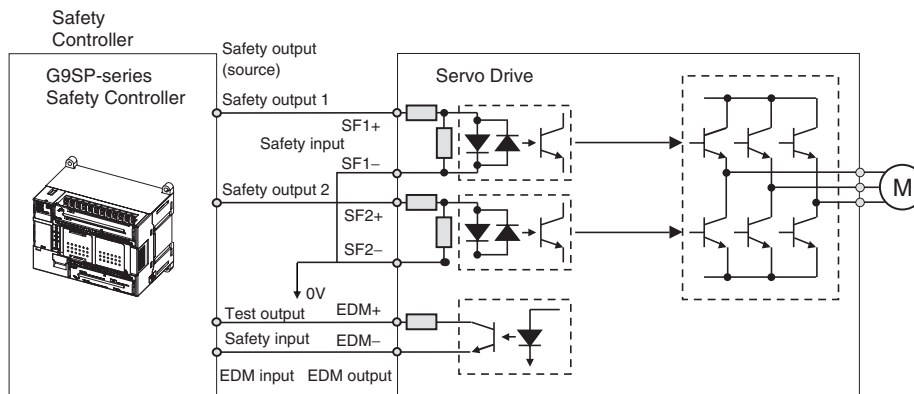

9

Details on Servo Parameter Objects

This chapter explains the settings of each object.

9-1 Basic Settings	9-2
9-2 Gain Settings	9-7
9-3 Vibration Suppression Settings	9-20
9-4 Analog Control Objects	9-26
9-5 Interface Monitor Settings	9-31
9-6 Extended Objects	9-41
9-7 Special Objects	9-47

9-1 Basic Settings

This section describes objects specific to G5-series Servo Drives with built-in EtherCAT communications. G5-series Servo Drive parameters (Pn□□□) are allocated to objects 3000 to 3999 hex. Index 3□□□ hex correspond to G5-series Servo Drive parameters Pn□□□. For example, object 3504 hex is the same as parameter Pn504.



Precautions for Correct Use

Pn□□□ uses decimal numbers but object 3□□□ is a hexadecimal number.

- Some objects are enabled by turning the power supply OFF and then ON again. After changing these objects, turn OFF the power supply, confirm that the power supply indicator has gone OFF, and then turn ON the power supply again.
- Do not change the objects marked “reserved.” Also, do not change the set values that are indicted as being unused or reserved for the system.
- See below for the data attributes.

- A : Always enabled
- B : Prohibited to change during motor rotation or commands.
If it is changed during motor rotation or commands, the update timing will be unknown.
- C : Updated after the control power is reset, or after a Config command is executed via EtherCAT communications.
- D : Changeable only when the EtherCAT communications state is Pre-Operational (Pre-Op).
- R : Updated when the control power supply is reset.
It is not updated for a Config command via EtherCAT communications.
- : Write prohibited.

- The operation modes are shown as follows:

- All : All operation modes
- csp : Cyclic synchronous position mode
- csv : Cyclic synchronous velocity mode
- cst : Cyclic synchronous torque mode
- pp : Profile position mode
- hm : Homing mode
- (semi) : Only objects related to semi-closed control.
- (full) : Only objects related to fully-closed control.

3000 hex	Rotation Direction Switching						<input type="checkbox"/> All
Setting range	0 to 1	Unit	–	Default setting	1	Data attribute	C
Size	2 bytes (INT16)		Access	RW	PDO map	Not possible.	

- This object switches the motor rotation direction for a position, speed, or torque command.

Explanation of Set Values

Set value	Description
0	A forward direction command sets the motor rotation direction to clockwise.
1	A forward direction command sets the motor rotation direction to counterclockwise.

- The motor rotation direction when viewing the shaft from the load side is called clockwise (CW) or counterclockwise (CCW).

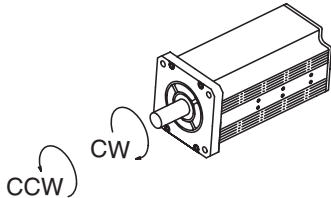

3001 hex	Control Mode Selection						All
Setting range	0 to 6	Unit	–	Default setting	0	Data attribute	R
Size	2 bytes (INT16)		Access	RW	PDO map	Not possible.	

- Set the control mode to be used.

Explanation of Set Values

Set value	Description
0 to 5	Semi-closed control ^{*1}
6	Fully-closed control

*1 Set any value between 0 and 5 for semi-closed control.

3002 hex	Realtime Autotuning Mode Selection						All
Setting range	0 to 6	Unit	–	Default setting	1	Data attribute	B
Size	2 bytes (INT16)		Access	RW	PDO map	Not possible.	

- Set the operating mode for realtime autotuning.
- Refer to *11-3 Realtime Autotuning* on page 11-7.

Explanation of Set Values

Set value	Realtime autotuning	Description
0	Disabled	Realtime autotuning is disabled.
1	Focus on stability (default setting)	No unbalanced load, friction compensation, or gain switching.
2	Focus on position control	Used for a horizontal axis or other axes that have no unbalanced load, or for a ball screw drive with little friction.
3	Vertical axis	Used when an unbalanced load is present, such as a vertical axis.
4	Friction compensation and vertical axis	Used when friction is large (unbalanced load also calculated). Used for a belt-driving shaft with large friction. Variations in finalizing the positioning are suppressed.
5	Load characteristic estimation	Used only for estimating load characteristics.
6	Customization	This mode is used for customizing the realtime autotuning function by using the Realtime Autotuning Customization Mode Setting (3632 hex).

3003 hex	Realtime Autotuning Machine Rigidity Setting						All
Setting range	0 to 31	Unit	–	Default setting	13 *1	Data attribute	B
Size	2 bytes (INT16)		Access	RW	PDO map	Not possible.	

*1 The default setting is 11 for a Drive with 200 V and 1 kW or greater, or for a Drive with 400 V.

- Set the machine rigidity to one of 32 levels when realtime autotuning is enabled.
- The higher the machine rigidity set value is, the higher the responsiveness is, however, the more vibration occurs.

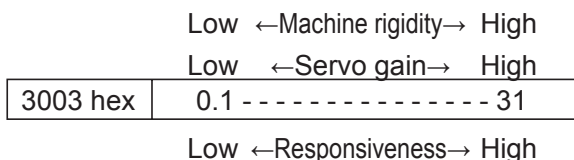

- Refer to *11-3 Realtime Autotuning* on page 11-7.



Precautions for Correct Use

- If the set value is changed suddenly by a large amount, the gain may change rapidly, subjecting the machine to shock. Always start with a small setting, and gradually increase the setting while monitoring machine operation.

3004 hex	Inertia Ratio						All
Setting range	0 to 10000	Unit	%	Default setting	250	Data attribute	B
Size	2 bytes (INT16)		Access	RW	PDO map	Not possible.	

- Set the load inertia as a percentage of the motor rotor inertia.
- $3004 \text{ hex} = (\text{Load inertia} / \text{Rotor inertia}) \times 100\%$
- When realtime autotuning is enabled, the inertia ratio is continuously estimated and saved in EEPROM every 30 minutes.
- If the inertia ratio is set correctly, the setting unit for the Speed Loop Gain 1 (3101 hex) and Speed Loop Gain 2 (3106 hex) is Hz.
- If the Inertia Ratio (3004 hex) is set larger than the actual value, the setting for speed loop gain will increase. If the Inertia Ratio (3004 hex) is set smaller than the actual value, the setting for speed loop gain will decrease.

3013 hex	External Torque Limit 1						All
Setting range	0 to 5000	Unit	0.1 %	Default setting	5000*1	Data attribute	B
Size	2 bytes (INT16)		Access	RW	PDO map	Not possible.	

*1 It is limited by the maximum torque of the connected motor.

- Set the limit values for the motor output torques (3013 hex: External Torque Limit 1, 3522 hex: External Torque Limit 2).
- Refer to the Torque Limit Selection (3521 hex) for the torque limit selection.
- During torque control, it limits the maximum torque in forward and reverse directions. The settings on the Torque Limit Selection (3521 hex) and the External Torque Limit 2 (3522 hex) are ignored.
- Set the value in units of 0.1% of the rated torque (100%).
E.g. When the set value is 1500, the maximum torque is limited to 150.0%.

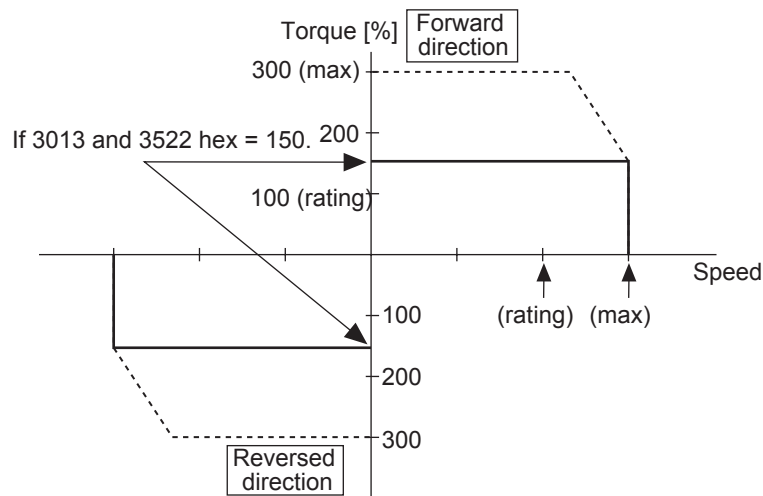

- Refer to 7-7 Torque Limit Switching on page 7-24 for the torque control and the torque limit selection.

3015 hex	Operation Switch when Using Absolute Encoder						All (semi)
Setting range	0 to 2	Unit	–	Default setting	2	Data attribute	C
Size	2 bytes (INT16)		Access	RW	PDO map	Not possible.	

- Set the operating method for the 17-bit absolute encoder.

Explanation of Set Values

Set value	Description
0	Use as absolute encoder.
1	Use as incremental encoder.
2	Use as absolute encoder but ignore multi-rotation counter overflow.

3016 hex	Regeneration Resistor Selection						<input type="button" value="All"/>
Setting range	0 to 3	Unit	–	Default setting	3 ^{*1}	Data attribute	C
Size	2 bytes (INT16)		Access	RW	PDO map	Not possible.	

*1 The default setting is 0 for a Drive with 100 V and 400 W, with 200 V and 750 W or greater, or with 400 V.

- The setting is different whether the Regeneration Resistor built in the Drive is directly used, or it is removed and replaced by an External Regeneration Resistor. In the latter case, the resistor is connected to the External Regeneration Resistor connection terminal.

Explanation of Set Values

Set value	Description
0	Regeneration Resistor used: Built-in Resistor The regeneration processing circuit operates and the Regeneration Overload Error (Error No. 18.0) are enabled according to the Built-in Resistor (with approx. 1% duty).
1	Regeneration Resistor used: External Resistor The regeneration processing circuit operates, and Regeneration Overload Error (Error No. 18.0) cause a trip when the operating rate of the Regeneration Resistor exceeds 10%.
2	Regeneration Resistor used: External Resistor The regeneration processing circuit operates, but Regeneration Overload Error (Error No. 18.0) do not occur.
3	Regeneration Resistor used: None The regeneration processing circuit and Regeneration Overload Error (Error No. 18.0) do not operate, and all regenerative energy is processed by the built-in capacitor.



Precautions for Correct Use

- Do not touch the External Regeneration Resistor. A burn injury may result.
- Always provide a temperature fuse or other protective measure when using an External Regeneration Resistor. Regardless of whether the regeneration overload error is enabled or disabled, the Regeneration Resistor can generate heat and may cause burning.
- To use the Built-in Regeneration Resistor, always set this object to 0.

3017 hex	External Regeneration Resistor Setting						<input type="button" value="All"/>
Setting range	0 to 4	Unit	–	Default setting	0	Data attribute	C
Size	2 bytes (INT16)		Access	RW	PDO map	Not possible.	

- Select the method to calculate the regeneration resistance load ratio, when the External Resistor is selected in the Regeneration Resistor Selection (3016 hex = 1 or 2).

Explanation of Set Values

Set value	Description
0	Regeneration load ratio is 100% when operating rate of the External Regeneration Resistor is 10%.
1	Reserved
2	Reserved
3	Reserved
4	Reserved

9-2 Gain Settings

Refer to *11-2 Gain Adjustment* on page 11-5 for the settings for gain adjustment.

3100 hex	Position Loop Gain 1						csp	pp	hm
Setting range	0 to 30000	Unit	0.1/s	Default setting	480 ^{*1}	Data attribute	B		
Size	2 bytes (INT16)		Access	RW	PDO map	Not possible.			

*1 The default setting is 320 for a Drive with 200 V and 1 kW or greater, or with 400 V.

- Set the position loop response in accordance with the machine rigidity.
- The responsiveness of the servo system is determined by the position loop gain.
- Servo systems with a high position loop gain have a high responsiveness and fast positioning.
- To increase the position loop gain, you must improve machine rigidity and increase the specific damping frequency. This should be 500 to 700 (0.1/s) for ordinary machine tools, 300 to 500 (0.1/s) for general-use and assembly machines, and 100 to 300 (0.1/s) for industrial robots. The default position loop gain is 480 (0.1/s), so be sure to lower the set value for machines with low machine rigidity.
- Increasing the position loop gain in systems with low machine rigidity or systems with low specific damping frequencies may cause machine resonance, resulting in an overload error.
- If the position loop gain is low, you can shorten the positioning time using feed-forward.
- This object is automatically changed by executing realtime autotuning. To set it manually, set the Realtime Autotuning Mode Selection (3002 hex) to 0.

Position loop gain is generally expressed as follows:

$$\text{Position loop gain (Kp)} = \frac{\text{Command pulse frequency (pulses/s)}}{\text{Pulse position error (pulses)}} \quad (0.1/\text{s})$$

Response for Position Loop Gain Changes

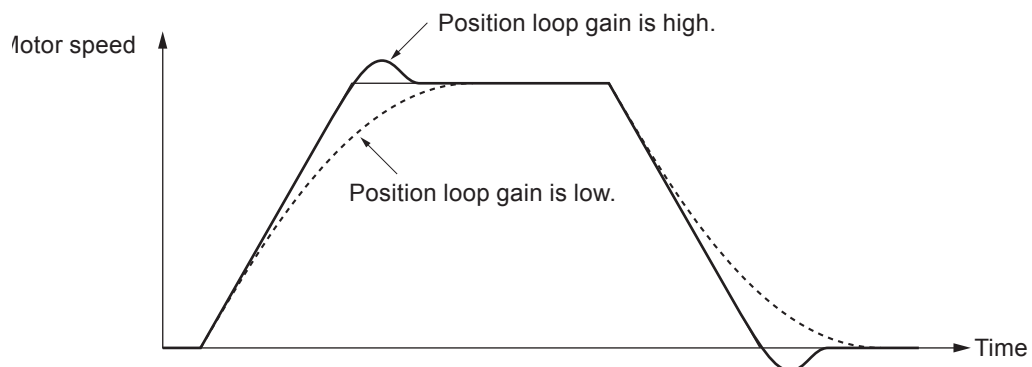

- If the speed loop gain and position loop gain are optimally set, the motor operation for the command delays $2/K_p$ at acceleration and delays $3/K_p$ at deceleration.

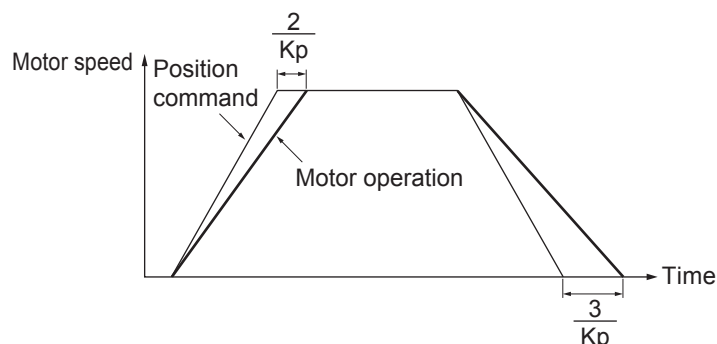

3101 hex	Speed Loop Gain 1						All
Setting range	1 to 32767	Unit	0.1 Hz	Default setting	270*1	Data attribute	B
Size	2 bytes (INT16)		Access	RW	PDO map	Not possible.	

*1 The default setting is 180 for a Drive with 200 V and 1 kW or greater, or with 400 V.

- This object determines speed loop responsiveness.
- The setting for the speed loop gain must be increased to increase the position loop gain and improve the responsiveness of the entire servo system. Setting too high, however, may result in vibration.
- The setting unit for 3101 hex is Hz if the Inertia Ratio (3004 hex) is set correctly.

When the speed loop gain is changed, the response is as shown in the following diagram.

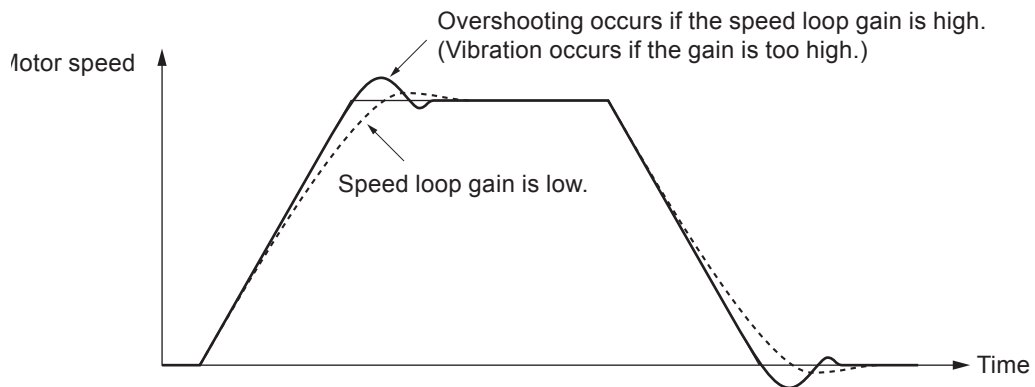

3102 hex	Speed Loop Integral Time Constant 1						All
Setting range	1 to 10000	Unit	0.1 ms	Default setting	210*1	Data attribute	B
Size	2 bytes (INT16)		Access	RW	PDO map	Not possible.	

*1 The default setting is 310 for a Drive with 200 V and 1 kW or greater, or with 400 V.

- Set the speed loop integral time constant.
- The smaller the set value, the faster the error approaches 0 when stopping.

When the speed loop integral time constant is changed, the response is as shown in the following diagram.

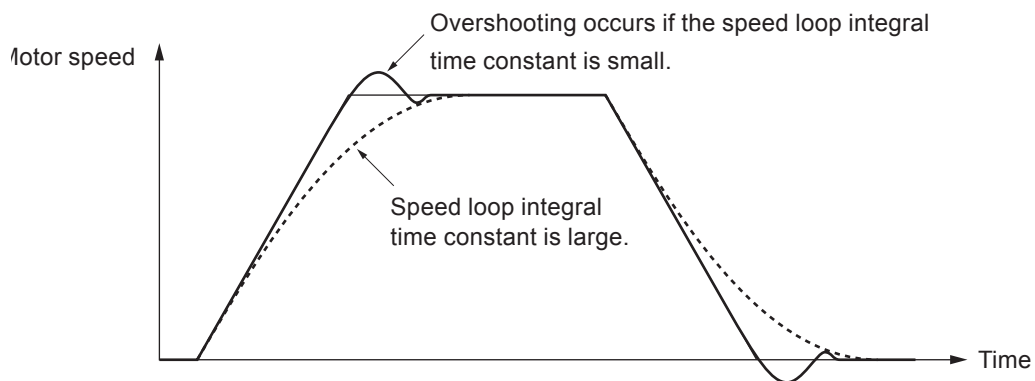

3103 hex	Speed Feedback Filter Time Constant 1						<input type="button" value="All"/>	
Setting range	0 to 5	Unit	–	Default setting	0	Data attribute	B	
Size	2 bytes (INT16)		Access	RW	PDO map	Not possible.		

- Set the time constant for the low pass filter (LPF) after speed detection to one of 6 levels (0 to 5).
- Increasing the set value increases the time constant and decreases the noise generated by the motor. Responsiveness, however, also decreases.
- Normally, use the default set value.

3104 hex	Torque Command Filter Time Constant 1						<input type="button" value="All"/>	
Setting range	0 to 2500	Unit	0.01 ms	Default setting	84* ¹	Data attribute	B	
Size	2 bytes (INT16)		Access	RW	PDO map	Not possible.		

*1 The default setting is 126 for a Drive with 200 V and 1 kW or greater, or with 400 V.

- Set the time constant for the first-order lag filter inserted into the torque command.
- This object may be effective in suppressing vibration due to torsion resonance.

3105 hex	Position Loop Gain 2						<input type="button" value="csp"/> <input type="button" value="pp"/> <input type="button" value="hm"/>	
Setting range	0 to 30000	Unit	0.1/s	Default setting	570* ¹	Data attribute	B	
Size	2 bytes (INT16)		Access	RW	PDO map	Not possible.		

*1 The default setting is 380 for a Drive with 200 V and 1 kW or greater, or with 400 V.

- Set the responsiveness of the position control system for the second position loop.

3106 hex	Speed Loop Gain 2						<input type="button" value="All"/>	
Setting range	1 to 32767	Unit	0.1 Hz	Default setting	270* ¹	Data attribute	B	
Size	2 bytes (INT16)		Access	RW	PDO map	Not possible.		

*1 The default setting is 180 for a Drive with 200 V and 1 kW or greater, or with 400 V.

- Set the responsiveness of the second speed loop.

3107 hex	Speed Loop Integral Time Constant 2						<input type="button" value="All"/>	
Setting range	1 to 10000	Unit	0.1 ms	Default setting	10000	Data attribute	B	
Size	2 bytes (INT16)		Access	RW	PDO map	Not possible.		

- Set the second speed loop integral time constant.

3108 hex	Speed Feedback Filter Time Constant 2						<input type="button" value="All"/>	
Setting range	0 to 5	Unit	–	Default setting	0	Data attribute	B	
Size	2 bytes (INT16)		Access	RW	PDO map	Not possible.		

- Set the second speed feedback filter.

3109 hex	Torque Command Filter Time Constant 2						<input type="checkbox"/> All	
Setting range	0 to 2500	Unit	0.01 ms	Default setting	84 ^{*1}	Data attribute	B	
Size	2 bytes (INT16)		Access	RW	PDO map	Not possible.		

*1 The default setting is 126 for a Drive with 200 V and 1 kW or greater, or with 400 V.

- Set the second torque filter time constant.
- The objects from 3105 to 3109 hex are the gain and time constants to be selected when the Gain Switching Input Operating Mode Selection (3114 hex) is enabled.
- The gain is switched according to the condition set in the Switching Mode (3115 hex, 3120 hex, and 3124 hex).
- If the mechanical system inertia changes greatly or if you want to change the responsiveness depending on whether the motor is rotating or being stopped, you can achieve the appropriate control by setting the gains and time constants beforehand for each of these conditions, and switching them according to the condition.
- This object is automatically changed by executing realtime autotuning function. To set it manually, set the Realtime Autotuning Mode Selection (3002 hex) to 0.

3110 hex	Speed Feed-forward Gain						<input type="checkbox"/> csp <input type="checkbox"/> pp <input type="checkbox"/> hm	
Setting range	0 to 1000	Unit	0.1%	Default setting	300	Data attribute	B	
Size	2 bytes (INT16)		Access	RW	PDO map	Not possible.		

- Set the feed-forward gain.
- Increasing the set value decreases the position error and increases the responsiveness. Overshooting, however, will occur more easily.
- Refer to *11-11 Feed-forward Function* on page 11-31.

3111 hex	Speed Feed-forward Command Filter						<input type="checkbox"/> csp <input type="checkbox"/> pp <input type="checkbox"/> hm	
Setting range	0 to 6400	Unit	0.01 ms	Default setting	50	Data attribute	B	
Size	2 bytes (INT16)		Access	RW	PDO map	Not possible.		

- Set the time constant for the first-order lag filter inserted into the feed-forward.
- Setting the filter may improve operation if speed overshooting occurs or the noise during operation is large when the feed-forward is set high.
- Refer to *11-11 Feed-forward Function* on page 11-31.

3112 hex	Torque Feed-forward Gain						<input type="checkbox"/> csp <input type="checkbox"/> csv <input type="checkbox"/> pp <input type="checkbox"/> hm	
Setting range	0 to 1000	Unit	0.1%	Default setting	0	Data attribute	B	
Size	2 bytes (INT16)		Access	RW	PDO map	Not possible.		

- Set the feed-forward gain in torque control. Increasing the set value decreases the position error and increases the responsiveness. Overshooting, however, will occur more easily.
- Refer to *11-11 Feed-forward Function* on page 11-31.

3113 hex	Torque Feed-forward Command Filter						<input type="checkbox"/> csp <input type="checkbox"/> csv <input type="checkbox"/> pp <input type="checkbox"/> hm	
Setting range	0 to 6400	Unit	0.01 ms	Default setting	0	Data attribute	B	
Size	2 bytes (INT16)		Access	RW	PDO map	Not possible.		

- Set the time constant for the first-order lag filter inserted into the feed-forward.
- Setting the filter may improve operation if speed overshooting occurs or the noise during operation is large when the feed-forward is set high.
- Refer to *11-11 Feed-forward Function* on page 11-31.

3114 hex	Gain Switching Input Operating Mode Selection						<input type="checkbox"/> All	
Setting range	0 to 1	Unit	–	Default setting	1	Data attribute	B	
Size	2 bytes (INT16)		Access	RW	PDO map	Not possible.		

- Select either PI/P operation switching or gain 1/gain 2 switching.
- The PI/P operation switching is performed with the Speed Loop PI/P Control command in EtherCAT communications.
- Refer to *7-10 Gain Switching 3 Function* on page 7-38 for the Gain 1/Gain 2 switching.

Explanation of Set Values

Set value	Description
0	Gain 1 (PI/P switching enabled)
1	Gain 1/gain 2 switching available

3115 hex	Switching Mode in Position Control						<input type="checkbox"/> csp <input type="checkbox"/> pp	
Setting range	0 to 10	Unit	–	Default setting	0	Data attribute	B	
Size	2 bytes (INT16)		Access	RW	PDO map	Not possible.		

- Select the conditions for switching between gain 1 and gain 2 when the Gain Switching Input Operating Mode Selection (3114 hex) is set to 1.

Explanation of Settings

3115 hex set value	Description			
	Gain switching conditions	Gain Switching Delay Time in Position Control (3116 hex) ^{*1}	Gain Switching Level in Position Control (3117 hex)	Gain Switching Hysteresis in Position Control (3118 hex) ^{*2}
0	Always Gain 1 (3100 to 3104 hex).	Disabled	Disabled	Disabled
1	Always Gain 2 (3105 to 3109 hex).	Disabled	Disabled	Disabled
2	Gain switching command input via EtherCAT communications ^{*3}	Disabled	Disabled	Disabled
3	Command torque value (Refer to Figure A.)	Enabled	Enabled ^{*4} (%)	Enabled ^{*4} (%)
4	Always Gain 1 (3100 to 3104 hex).	Disabled	Disabled	Disabled
5	Command speed (Refer to Figure B.)	Enabled	Enabled (r/min)	Enabled (r/min)
6	Pulse position error (Refer to Figure C.)	Enabled	Enabled ^{*5} (pulse)	Enabled ^{*5} (pulse)
7	Whether there is a position command (Refer to Figure D.)	Enabled	Disabled	Disabled
9	Actual motor speed (Refer to Figure B.)	Enabled	Enabled (r/min)	Enabled (r/min)
10	Combination of whether there is a position command and actual motor speed (Refer to Figure E.)	Enabled	Enabled ^{*6} (r/min)	Enabled ^{*6} (r/min)

^{*1} The Gain Switching Delay Time in Position Control (3116 hex) becomes effective when the gain is switched from 2 to 1.

*2 The Gain Switching Hysteresis in Position Control (3118 hex) is defined in the drawing below.

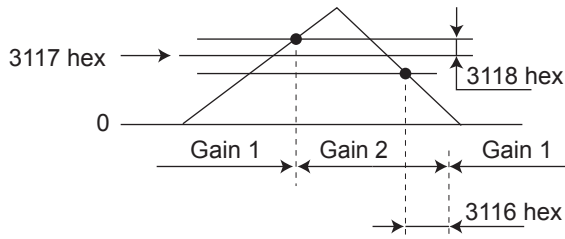

If object 3117 hex is less than object 3118 hex, object 3117 hex will automatically be set to the same value as object 3118 hex.

- *3 When the Gain Switching command of EtherCAT communications is 0, the gain switches to gain 1. When the command is 1, the gain switches to gain 2.
- *4 Set the percentage of the rated torque.
Example: To set 10% of the rated torque, set the set value would be 10.
- *5 The position error is set according to the encoder resolution (i.e., pulses) for position control and according to the external encoder resolution (i.e., pulses) for fully-closed control.
- *6 When the set value is 10, meanings of the Gain Switching Delay Time in Position Control, the Gain Switching Level in Position Control, and the Gain Switching Hysteresis in Position Control differ from the normal case. (Refer to Figure E.)

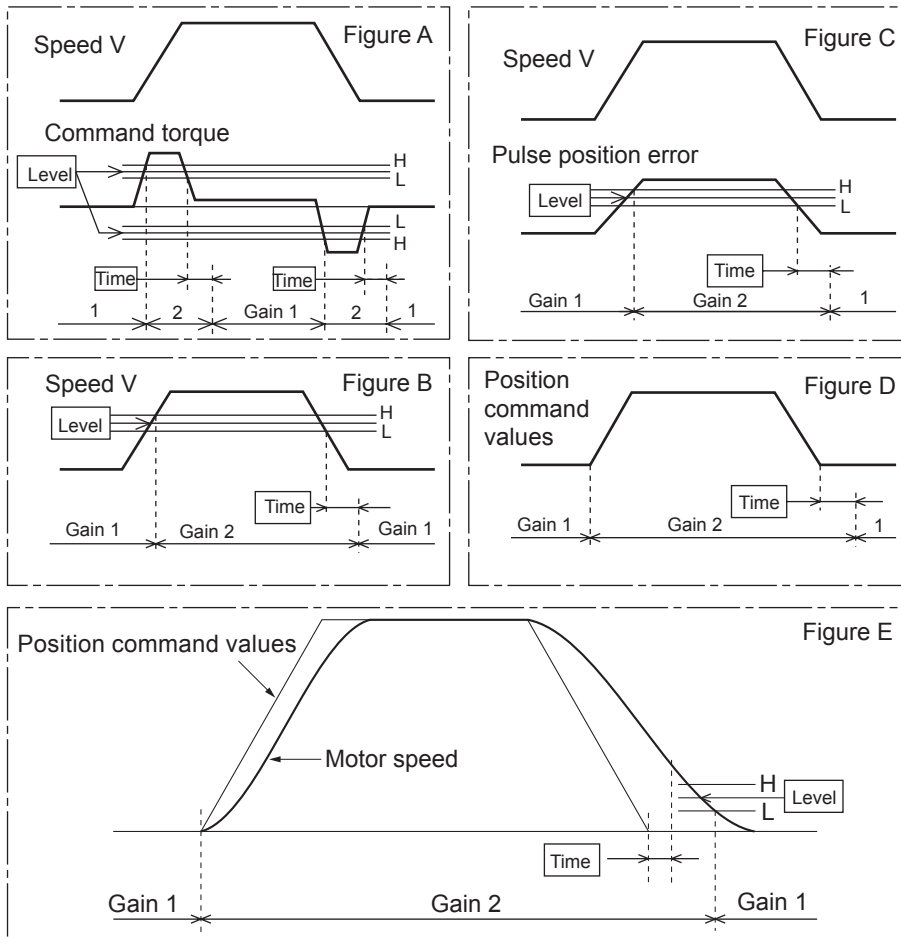

3116 hex	Gain Switching Delay Time in Position Control						<input type="checkbox"/> csp	<input type="checkbox"/> pp	<input type="checkbox"/> hm
Setting range	0 to 10000	Unit	0.1 ms	Default setting	50	Data attribute	B		
Size	2 bytes (INT16)		Access	RW	PDO map	Not possible.			

- Set the delay time when returning from gain 2 to gain 1 if the Switching Mode in Position Control (3115 hex) is set to 3 or 5 to 10.

3117 hex	Gain Switching Level in Position Control						<input type="checkbox"/> csp	<input type="checkbox"/> pp	<input type="checkbox"/> hm
Setting range	0 to 20000	Unit	–	Default setting	50	Data attribute	B		
Size	2 bytes (INT16)		Access	RW	PDO map	Not possible.			

- This object is enabled when the Switching Mode in Position Control (3115 hex) is 3, 5, 6, 9 or 10. It sets the judgment level for switching between gain 1 and gain 2.
- The unit depends on the Switching Mode in Position Control (3115 hex).

3118 hex	Gain Switching Hysteresis in Position Control						<input type="checkbox"/> csp	<input type="checkbox"/> pp	<input type="checkbox"/> hm
Setting range	0 to 20000	Unit	–	Default setting	33	Data attribute	B		
Size	2 bytes (INT16)		Access	RW	PDO map	Not possible.			

- Set the hysteresis width above and below the judgment level set in the Gain Switching Level in Position Control (3117 hex).
- The unit depends on the setting of the Switching Mode in Position Control (3115 hex).
- The following shows the definitions for the Gain Switching Delay Time in Position Control (3116 hex), Gain Switching Level in Position Control (3117 hex), and Gain Switching Hysteresis in Position Control (3118 hex).

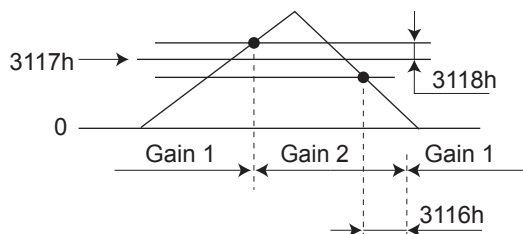

- The settings for the Gain Switching Level in Position Control (3117 hex) and the Gain Switching Hysteresis in Position Control (3118 hex) are enabled as absolute values (positive/negative).

3119 hex	Position Gain Switching Time						csp pp hm
Setting range	0 to 10000	Unit	0.1 ms	Default setting	33	Data attribute	B
Size	2 bytes (INT16)		Access	RW	PDO map	Not possible.	

- Torque fluctuations or vibration will occur if the position loop gain is changed too quickly during position control or fully-closed control. To suppress these, set a Position Gain Switching Time (3119 hex).
- By setting the Position Gain Switching Time (3119 hex), the gain will be switched gradually when there is a large change in the position loop gain.
- If there is a large difference between Position Loop Gain 1 (3100 hex) and Position Loop Gain 2 (3105 hex), set the Position Gain Switching Time (3119 hex).
- When the position loop gain 1 increases, the gain changes in the set time.

Position Loop Gain 1 < Position Loop Gain 2

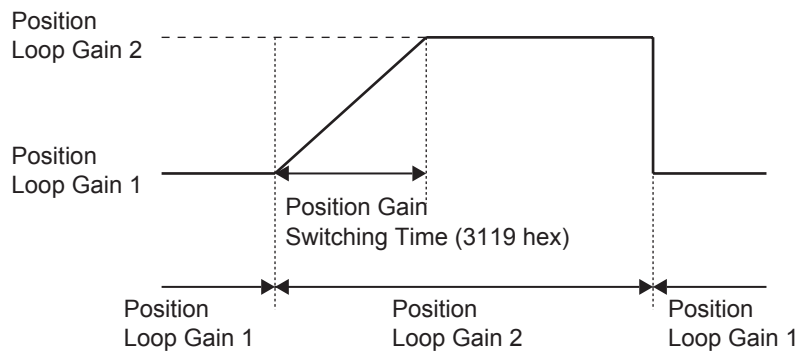

Precautions for Correct Use

When the position loop gain is switched to a smaller value (e.g., when switching from gain 2 to gain 1 in the above figure), Position Gain Switching Time (3119 hex) is ignored and the gain is switched immediately.

3120 hex	Switching Mode in Speed Control						CSV
Setting range	0 to 5	Unit	–	Default setting	0	Data attribute	B
Size	2 bytes (INT16)		Access	RW	PDO map	Not possible.	

- Select the conditions for switching between gain 1 and gain 2 when the Gain Switching Input Operating Mode Selection (3114 hex) is set to 1.
- The gain is always gain 1 regardless of the gain input if the Switching Mode in Speed Control (3120 hex) is 2 and the Torque Limit Selection (3521 hex) is 3 or 6.

Explanation of Settings

3120 hex set value	Description			
	Gain switching conditions	Gain Switching Delay Time in Speed Control (3121 hex) ^{*1}	Gain Switching Level in Speed Control (3122 hex)	Gain Switching Hysteresis in Speed Control (3123 hex) ^{*2}
0	Always the Gain 1 (3100 to 3104 hex).	Disabled	Disabled	Disabled
1	Always the Gain 2 (3105 to 3109 hex).	Disabled	Disabled	Disabled
2	Gain switching command input via EtherCAT communications ^{*3}	Disabled	Disabled	Disabled
3	Torque command variation (Refer to Figure A.)	Enabled	Enabled ^{*3} (0.05%)	Enabled ^{*3} (0.05%)
4	Speed command variation (Refer to Figure B.)	Enabled	Enabled ^{*4} (10 r/min/s)	Enabled ^{*4} (10 r/min/s)
5	Speed command (Refer to Figure C.)	Enabled	Enabled (r/min)	Enabled (r/min)

*1 The Gain Switching Delay Time in Speed Control (3121 hex) becomes effective when the gain is switched from 2 to 1.

*2 The Gain Switching Hysteresis in Speed Control (3123 hex) is defined in the drawing below.

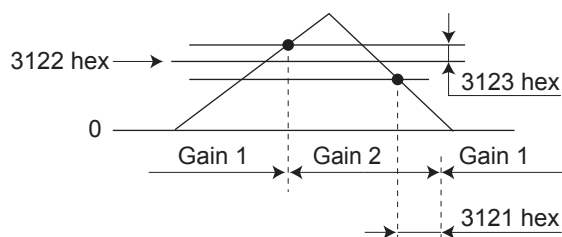

*3 When the Gain switching command of EtherCAT communications (G-SEL) is 0, the gain switches to Gain 1. When the command is 1, the gain switches to Gain 2.

*4 The variation means the change amount in a millisecond (ms).
E.g. The set value is 200 when the condition is a 10% change in torque in 1 millisecond.

*5 When the set value is 10, meanings of the Gain Switching Delay Time in Speed Control (3121 hex), the Gain Switching Level in Speed Control (3122 hex), and the Gain Switching Hysteresis in Speed Control (3123 hex) differ from the normal case. (Refer to Figure D.)

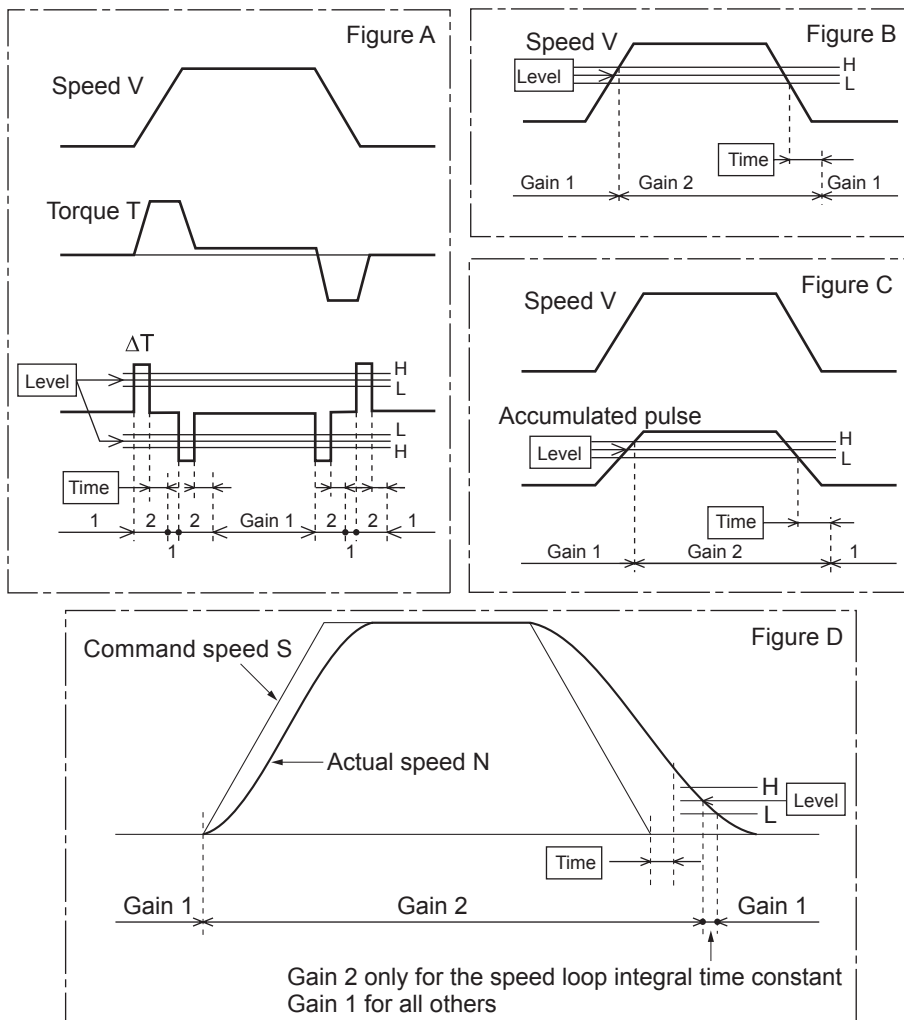

3121 hex	Gain Switching Delay Time in Speed Control						CSV
Setting range	0 to 10000	Unit	0.1 ms	Default setting	0	Data attribute	B
Size	2 bytes (INT16)		Access	RW	PDO map	Not possible.	

- Set the delay time when returning from gain 2 to gain 1 if the Switching Mode in Speed Control (3120 hex) is set to 3 to 5.

3122 hex	Gain Switching Level in Speed Control						CSV
Setting range	0 to 20000	Unit	–	Default setting	0	Data attribute	B
Size	2 bytes (INT16)		Access	RW	PDO map	Not possible.	

- In Speed Control Mode, this is enabled when the Switching Mode in Speed Control (3120 hex) is set to 3 to 5. Set the judgment level for switching between gain 1 and gain 2.
- The unit depends on the Switching Mode in Speed Control (3120 hex).

3123 hex	Gain Switching Hysteresis in Speed Control						CSV
Setting range	0 to 20000	Unit	–	Default setting	0	Data attribute	B
Size	2 bytes (INT16)		Access	RW	PDO map	Not possible.	

- Set the hysteresis width above and below the judgment level set in the Gain Switching Level in Speed Control (3122 hex).
- The unit depends on the setting of the Switching Mode in Speed Control (3120 hex).
- The following shows the definitions for the Gain Switching Delay Time in Speed Control (3121 hex), Gain Switching Level in Speed Control (3122 hex), and Gain Switching Hysteresis in Speed Control (3123 hex).

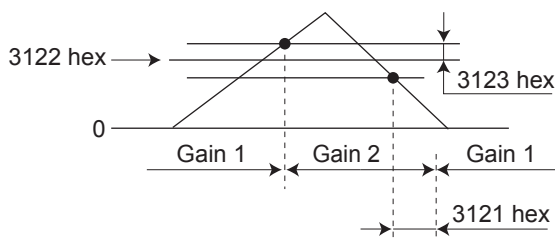

- The settings for the Gain Switching Level in Speed Control (3122 hex) and the Gain Switching Hysteresis in Speed Control (3123 hex) are enabled absolute values (positive/negative).

3124 hex	Switching Mode in Torque Control						cst
Setting range	0 to 3	Unit	–	Default setting	0	Data attribute	B
Size	2 bytes (INT16)		Access	RW	PDO map	Not possible.	

- Select the switching condition between gain 1 and gain 2 when the Gain Switching Input Operating Mode Selection (3114 hex) is set to 1.
- The gain is always gain 1 regardless of the gain input if the Switching Mode in Torque Control (3124 hex) is 2 and the Torque Limit Selection (3521 hex) is 3 or 6.

Explanation of Settings

3124 hex set value	Description			
	Gain switching conditions	Gain Switching Delay Time in Torque Control (3125 hex) *1	Gain Switching Level in Torque Control (3126 hex)	Gain Switching Hysteresis in Torque Control (3127 hex) *2
0	Always Gain 1 (3100 to 3104 hex).	Disabled	Disabled	Disabled
1	Always Gain 2 (3105 to 3109 hex).	Disabled	Disabled	Disabled
2	Gain switching command input via EtherCAT communications *3	Disabled	Disabled	Disabled
3	Torque command variation (Refer to Figure A.)	Enabled	Enabled *4 (0.05%)	Enabled *4 (0.05%)

*1 The Gain Switching Delay Time in Toque Control (3125 hex) becomes effective when the gain is switched from 2 to 1.

*2 The Gain Switching Hysteresis in Torque Control (3127 hex) is defined in the drawing below.

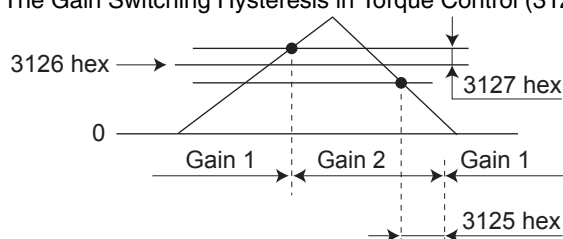

- *3 When the Gain switching command of EtherCAT communications is 0, the gain switches to Gain 1. When the command is 1, the gain switches to Gain 2.
- *4 The variation means the change amount in a millisecond (ms).
E.g. The set value is 200 when the condition is a 10% change in torque in 1 millisecond.

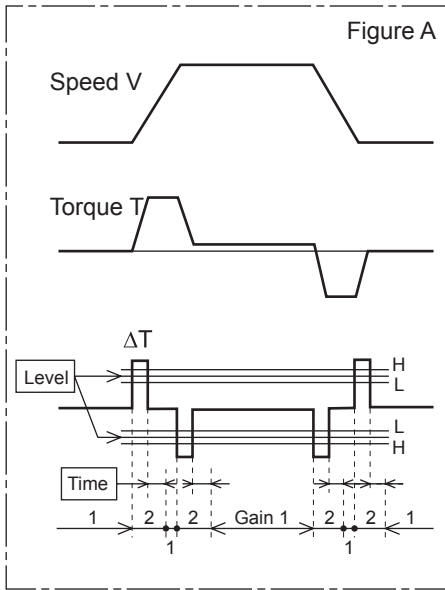

3125 hex	Gain Switching Delay Time in Torque Control						cst
Setting range	0 to 10000	Unit	–	Default setting	0	Data attribute	B
Size	2 bytes (INT16)		Access	RW	PDO map	Not possible.	

- Set the delay time when returning from gain 2 to gain 1 if the Switching Mode in Torque Control (3124 hex) is set to 3.

3126 hex	Gain Switching Level in Torque Control						cst
Setting range	0 to 20000	Unit	–	Default setting	0	Data attribute	B
Size	2 bytes (INT16)		Access	RW	PDO map	Not possible.	

- This is enabled when the Switching Mode in Torque Control (3124 hex) is set to 3. It sets the judgment level for switching between gain 1 and gain 2.
- The unit depends on the setting of Switching Mode in Torque Control (3124 hex).

3127 hex	Gain Switching Hysteresis in Torque Control						cst
Setting range	0 to 20000	Unit	–	Default setting	0	Data attribute	B
Size	2 bytes (INT16)		Access	RW	PDO map	Not possible.	

- Set the hysteresis width above and below the judgment level set in the Gain Switching Level in Torque Control (3126 hex).
- The unit depends on the setting of Switching Mode in Torque Control (3124 hex).
- The following shows the definitions for the Gain Switching Delay Time in Torque Control (3125 hex), Gain Switching Level in Torque Control (3126 hex), and Gain Switching Hysteresis in Torque Control (3127 hex).

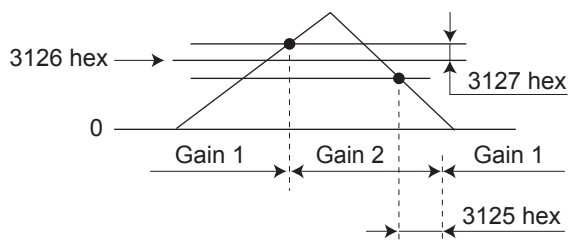

- The settings for the Gain Switching Level in Torque Control (3126 hex) and the Gain Switching Hysteresis in Torque Control (3127 hex) are enabled as absolute values (positive/negative).

9-3 Vibration Suppression Settings

3200 hex	Adaptive Filter Selection						<input type="checkbox"/> csp <input type="checkbox"/> csv <input type="checkbox"/> pp <input type="checkbox"/> hm	
Setting range	0 to 4	Unit	–	Default setting	0	Data attribute	B	
Size	2 bytes (INT16)		Access	RW	PDO map	Not possible.		

- Set the operation of the adaptive filter.
- Refer to *11-6 Adaptive Filter* on page 11-20.

Explanation of Set Values

Set value	Description
0	Adaptive filter disabled
1	One adaptive filter is enabled. The objects related to notch filter 3 are automatically updated.
2	Two adaptive filters are enabled. The objects related to notch filters 3 and 4 are updated.
3	For use by manufacturer. Do not use this setting.
4	Adaptive result is cleared. Objects related to notch filters 3 and 4 are disabled and the adaptive result is cleared.

3201 hex	Notch 1 Frequency Setting						<input type="checkbox"/> All	
Setting range	50 to 5000	Unit	Hz	Default setting	5000	Data attribute	B	
Size	2 bytes (INT16)		Access	RW	PDO map	Not possible.		

- Set the frequency of resonance suppression notch filter 1.
- The notch filter function is disabled if this object is set to 5000.
- Refer to *11-7 Notch Filters* on page 11-23.

3202 hex	Notch 1 Width Setting						<input type="checkbox"/> All	
Setting range	0 to 20	Unit	–	Default setting	2	Data attribute	B	
Size	2 bytes (INT16)		Access	RW	PDO map	Not possible.		

- Set the width of resonance suppression notch filter 1 to one of 20 levels.
- Increasing the setting value widens the notch width. Normally, use the default set value.
- Refer to *11-7 Notch Filters* on page 11-23.

3203 hex	Notch 1 Depth Setting						<input type="checkbox"/> All	
Setting range	0 to 99	Unit	–	Default setting	0	Data attribute	B	
Size	2 bytes (INT16)		Access	RW	PDO map	Not possible.		

- Set the notch depth of resonance suppression notch filter 1.
- Increasing the setting value shortens the notch depth and the phase lag.
- Refer to *11-7 Notch Filters* on page 11-23.

3204 hex	Notch 2 Frequency Setting						<input type="button" value="All"/>
Setting range	50 to 5000	Unit	Hz	Default setting	5000	Data attribute	B
Size	2 bytes (INT16)		Access	RW	PDO map	Not possible.	

- Set the notch frequency of resonance suppression notch filter 2.
- The notch filter function is disabled if this object is set to 5000.
- Refer to *11-7 Notch Filters* on page 11-23.

3205 hex	Notch 2 Width Setting						<input type="button" value="All"/>
Setting range	0 to 20	Unit	–	Default setting	2	Data attribute	B
Size	2 bytes (INT16)		Access	RW	PDO map	Not possible.	

- Select the notch width of resonance suppression notch filter 2.
- Increasing the setting value widens the notch width. Normally, use the default set value.
- Refer to *11-7 Notch Filters* on page 11-23.

3206 hex	Notch 2 Depth Setting						<input type="button" value="All"/>
Setting range	0 to 99	Unit	–	Default setting	0	Data attribute	B
Size	2 bytes (INT16)		Access	RW	PDO map	Not possible.	

- Set the notch depth of resonance suppression notch filter 2.
- Increasing the setting value shortens the notch depth and the phase lag.
- Refer to *11-7 Notch Filters* on page 11-23.

3207 hex	Notch 3 Frequency Setting						<input type="button" value="All"/>
Setting range	50 to 5000	Unit	Hz	Default setting	5000	Data attribute	B
Size	2 bytes (INT16)		Access	RW	PDO map	Not possible.	

- Set the notch frequency of resonance suppression notch filter 3.
- The notch filter function is disabled if this object is set to 5000.
- While the adaptive filter is enabled, the resonance frequency 1 that is assumed by the adaptive filter is automatically set. If no resonance point is found, the value 5000 is set.
- Refer to *11-6 Adaptive Filter* on page 11-20 and *11-7 Notch Filters* on page 11-23.

3208 hex	Notch 3 Width Setting						<input type="button" value="All"/>
Setting range	0 to 20	Unit	–	Default setting	2	Data attribute	B
Size	2 bytes (INT16)		Access	RW	PDO map	Not possible.	

- Select the notch width of resonance suppression notch filter 3.
- Increasing the setting value widens the notch width. Normally, use the default set value.
- While the adaptive filter is enabled, this object is set automatically.
- Refer to *11-6 Adaptive Filter* on page 11-20 and *11-7 Notch Filters* on page 11-23.

3209 hex	Notch 3 Depth Setting						<input type="text" value="All"/>	
Setting range	0 to 99	Unit	–	Default setting	0	Data attribute	B	
Size	2 bytes (INT16)		Access	RW	PDO map	Not possible.		

- Set the notch depth of resonance suppression notch filter 3.
- Increasing the setting value shortens the notch depth and the phase lag.
- While the adaptive filter is enabled, this object is set automatically.
- Refer to *11-6 Adaptive Filter* on page 11-20 and *11-7 Notch Filters* on page 11-23.

3210 hex	Notch 4 Frequency Setting						<input type="text" value="All"/>	
Setting range	50 to 5000	Unit	Hz	Default setting	5000	Data attribute	B	
Size	2 bytes (INT16)		Access	RW	PDO map	Not possible.		

- Set the notch frequency of resonance suppression notch filter 4.
- The notch filter function is disabled if this object is set to 5000.
- While two adaptive filters are enabled, the resonance frequency 2 that is assumed by the adaptive filter is automatically set. If no resonance point is found, the value 5000 is set.
- Refer to *11-6 Adaptive Filter* on page 11-20 and *11-7 Notch Filters* on page 11-23.

3211 hex	Notch 4 Width Setting						<input type="text" value="All"/>	
Setting range	0 to 20	Unit	–	Default setting	2	Data attribute	B	
Size	2 bytes (INT16)		Access	RW	PDO map	Not possible.		

- Select the notch width of resonance suppression notch filter 4.
- Increasing the setting value widens the notch width. Normally, use the default set value.
- This object is automatically set when two adaptive filters are enabled.
- Refer to *11-6 Adaptive Filter* on page 11-20 and *11-7 Notch Filters* on page 11-23.

3212 hex	Notch 4 Depth Setting						<input type="text" value="All"/>	
Setting range	0 to 99	Unit	–	Default setting	0	Data attribute	B	
Size	2 bytes (INT16)		Access	RW	PDO map	Not possible.		

- Set the notch depth of resonance suppression notch filter 4.
- Increasing the setting value shortens the notch depth and the phase lag.
- When two adaptive filters are enabled, this object is set automatically.
- Refer to *11-6 Adaptive Filter* on page 11-20 and *11-7 Notch Filters* on page 11-23.

3213 hex	Damping Filter Selection						<input type="checkbox"/> csp	<input type="checkbox"/> csv	<input type="checkbox"/> pp	<input type="checkbox"/> hm
Setting range	0 to 3	Unit	–	Default setting	0	Data attribute	B			
Size	2 bytes (INT16)		Access	RW	PDO map	Not possible.				

- Set the method to switch among four damping control filters.

Explanation of Set Values

Set value	Explanation
0	Up two damping filters, damping filters 1 and 2, can be used at the same time.
1	Reserved for manufacturer use *1
2	Reserved for manufacturer use *1
3	The damping filters are switched with position command direction. <ul style="list-style-type: none"> • Forward direction: Damping filters 1 / 3 enabled • Reverse direction: Damping filters 2 / 4 enabled

*1 The set value 1 and 2 are for manufacturer's use only. Users are not allowed to set 1 and 2 for this object.

3214 hex	Damping Frequency 1						<input type="checkbox"/> csp	<input type="checkbox"/> pp	<input type="checkbox"/> hm
Setting range	0 to 2000	Unit	0.1 Hz	Default setting	0	Data attribute	B		
Size	2 bytes (INT16)		Access	RW	PDO map	Not possible.			

- Set damping frequency 1 to suppress vibration at the end of the load in damping control.
- Measure the frequency of vibration at the end of the load and make the setting in units of 0.1 Hz.
- The range of setting frequency is 1.0 to 200.0 Hz. The function is disabled if the setting is 0 to 0.9 Hz.
- Refer to *11-5 Damping Control* on page 11-17.

3215 hex	Damping Filter 1 Setting						<input type="checkbox"/> csp	<input type="checkbox"/> pp	<input type="checkbox"/> hm
Setting range	0 to 1000	Unit	0.1 Hz	Default setting	0	Data attribute	B		
Size	2 bytes (INT16)		Access	RW	PDO map	Not possible.			

- First set Damping Frequency 1 (3214 hex). Then reduce the setting if torque saturation occurs or increase the setting to increase operation speed. Normally, use a setting of 0.
- The upper limit of the set value is restricted to the smaller value of the corresponding damping frequency or (2000 – damping frequency).
- Refer to *11-5 Damping Control* on page 11-17 for more information on settings.

3216 hex	Damping Frequency 2						<input type="checkbox"/> csp	<input type="checkbox"/> pp	<input type="checkbox"/> hm
Setting range	0 to 2000	Unit	0.1 Hz	Default setting	0	Data attribute	B		
Size	2 bytes (INT16)		Access	RW	PDO map	Not possible.			

- Set damping frequency 2 to suppress vibration at the end of the load in damping control.
- Measure the frequency of vibration at the end of the load and make the setting in units of 0.1 Hz.
- Setting frequency is 1.0 to 200.0 Hz. The function is disabled if the setting is 0 to 0.9 Hz.
- Refer to *11-5 Damping Control* on page 11-17 for more information on settings.

3217 hex	Damping Filter 2 Setting						<input type="checkbox"/> csp	<input type="checkbox"/> pp	<input type="checkbox"/> hm
Setting range	0 to 1000	Unit	0.1 Hz	Default setting	0	Data attribute	B		
Size	2 bytes (INT16)		Access	RW	PDO map	Not possible.			

- First set Damping Frequency 2 (3216 hex). Then reduce the setting if torque saturation occurs or increase the setting to increase operation speed. Normally, use a setting of 0.
- The upper limit of the set value is restricted to the smaller value of the corresponding damping frequency or (2000 – damping frequency).
- Refer to *11-5 Damping Control* on page 11-17 for more information on settings.

3218 hex	Damping Frequency 3						<input type="checkbox"/> csp	<input type="checkbox"/> pp	<input type="checkbox"/> hm
Setting range	0 to 2000	Unit	0.1 Hz	Default setting	0	Data attribute	B		
Size	2 bytes (INT16)		Access	RW	PDO map	Not possible.			

- Set damping frequency 3 to suppress vibration at the end of the load in damping control.
- Measure the frequency of vibration at the end of the load and make the setting in units of 0.1 Hz.
- Setting frequency is 1.0 to 200.0 Hz. The function is disabled if the setting is 0 to 0.9 Hz.
- Refer to *11-5 Damping Control* on page 11-17 for more information on settings.

3219 hex	Damping Filter 3 Setting						<input type="checkbox"/> csp	<input type="checkbox"/> pp	<input type="checkbox"/> hm
Setting range	0 to 1000	Unit	0.1 Hz	Default setting	0	Data attribute	B		
Size	2 bytes (INT16)		Access	RW	PDO map	Not possible.			

- First set Damping Frequency 3 (3218 hex). Then reduce the setting if torque saturation occurs or increase the setting to increase operation speed. Normally, use a setting of 0.
- The upper limit of the set value is restricted to the smaller value of the corresponding damping frequency or (2000 – damping frequency).
- Refer to *11-5 Damping Control* on page 11-17 for more information on settings.

3220 hex	Damping Frequency 4						<input type="checkbox"/> csp	<input type="checkbox"/> pp	<input type="checkbox"/> hm
Setting range	0 to 2000	Unit	0.1 Hz	Default setting	0	Data attribute	B		
Size	2 bytes (INT16)		Access	RW	PDO map	Not possible.			

- Set damping frequency 4 to suppress vibration at the end of the load in damping control.
- Measure the frequency of vibration at the end of the load and make the setting in units of 0.1 Hz.
- Setting frequency is 1.0 to 200.0 Hz. The function is disabled if the setting is 0 to 0.9 Hz.
- Refer to *11-5 Damping Control* on page 11-17 for more information on settings.

3221 hex	Damping Filter 4 Setting						<input type="checkbox"/> csp	<input type="checkbox"/> pp	<input type="checkbox"/> hm
Setting range	0 to 1000	Unit	0.1 Hz	Default setting	0	Data attribute	B		
Size	2 bytes (INT16)		Access	RW	PDO map	Not possible.			

- First set Damping Frequency 4 (3220 hex). Then reduce the setting if torque saturation occurs or increase the setting to increase operation speed. Normally, use a setting of 0.
- The upper limit of the set value is restricted to the smaller value of the corresponding damping frequency or (2000 – damping frequency).
- Refer to *11-5 Damping Control* on page 11-17 for more information on settings.

3222 hex	Position Command Filter Time Constant						<input type="checkbox"/> csp	<input type="checkbox"/> pp	<input type="checkbox"/> hm
Setting range	0 to 10000	Unit	0.1 ms	Default setting	0	Data attribute	B		
Size	2 bytes (INT16)		Access	RW	PDO map	Not possible.			

- The Position Command Filter Time Constant is the first-order lag filter that is inserted after the electronic gear ratio for the command input.
- This constant is used to reduce the stepping movement of the motor and achieve a smooth operation when the electronic gear ratio is set in 10 times or greater.
- It sets the first-order lag filter time constant, as shown below, for the square-wave command of target speed V_c .

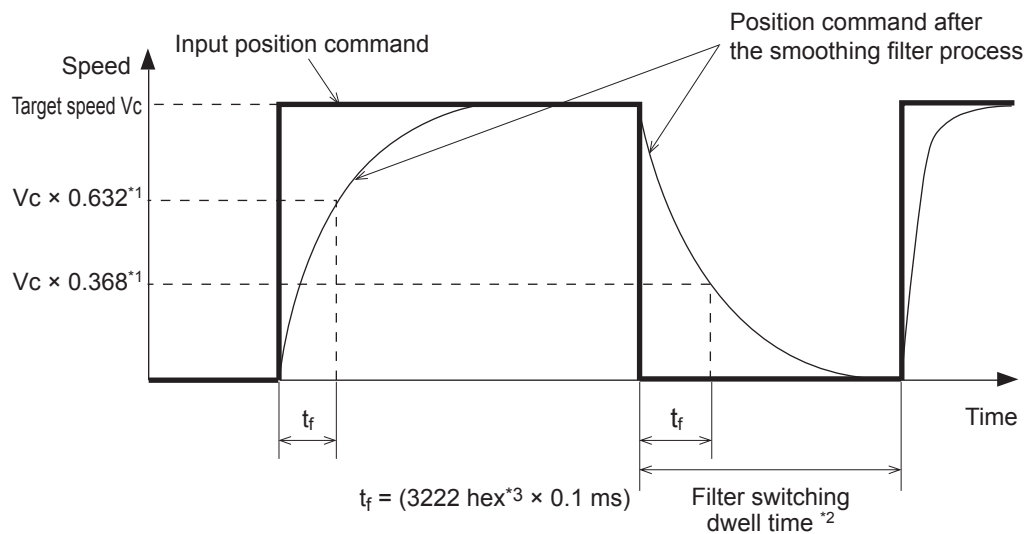

- *1 The error in the position command filter time constant is 0.4 max. (absolute error) for less than 100 ms and 0.2% max. (relative error) for 20 ms or greater for the set value times 0.1 ms.
- *2 The Position Command Filter Time Constant (3222 hex) is switched when the position command value per 0.250 ms changes from 0 to a value other than 0 while the positioning completed output is ON.
- *3 There is a delay from when the Position Command Filter Time Constant (3222 hex) is changed until the new value is applied in internal calculations. If the filter switch wait time expires during this delay, the change may be placed on hold.

9-4 Analog Control Objects

3312 hex	Soft Start Acceleration Time [CSV]						
Setting range	0 to 10000	Unit	ms/maximum motor speed	Default setting	0	Data attribute	B
Size	2 bytes (INT16)		Access	RW	PDO map	Not possible.	

3313 hex	Soft Start Deceleration Time [CSV]						
Setting range	0 to 10000	Unit	ms/maximum motor speed	Default setting	0	Data attribute	B
Size	2 bytes (INT16)		Access	RW	PDO map	Not possible.	

- Control the speed by setting acceleration/deceleration to the speed command inside the Servo Drive.
- A soft start can be set when inputting speed commands of stepping movement or when using internal speed setting.
- Do not set acceleration/deceleration time settings when using the Servo Drive in combination with an external position loop. (Set both 3312 and 3313 hex to 0.)
- Refer to 7-8 *Soft Start* on page 7-26.

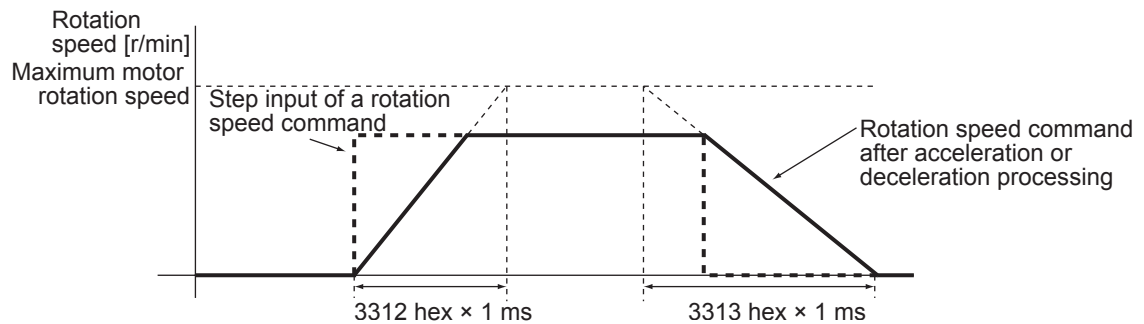

Precautions for Correct Use

- Do not set the Soft Start Acceleration Time and the Soft Start Deceleration Time when the position loop structure with a Host Controller is used.

3314 hex	S-curve Acceleration/Deceleration Time Setting						CSV
Setting range	0 to 1000	Unit	ms	Default setting	0	Data attribute	B
Size	2 bytes (INT16)		Access	RW	PDO map	Not possible.	

- Set the pseudo-S-curve acceleration/deceleration value to add to the speed command to enable smooth operation. This is useful for applications where impact may occur due to a large change in acceleration or deceleration when starting or stopping with linear acceleration or deceleration.
- Refer to *7-8 Soft Start* on page 7-26.

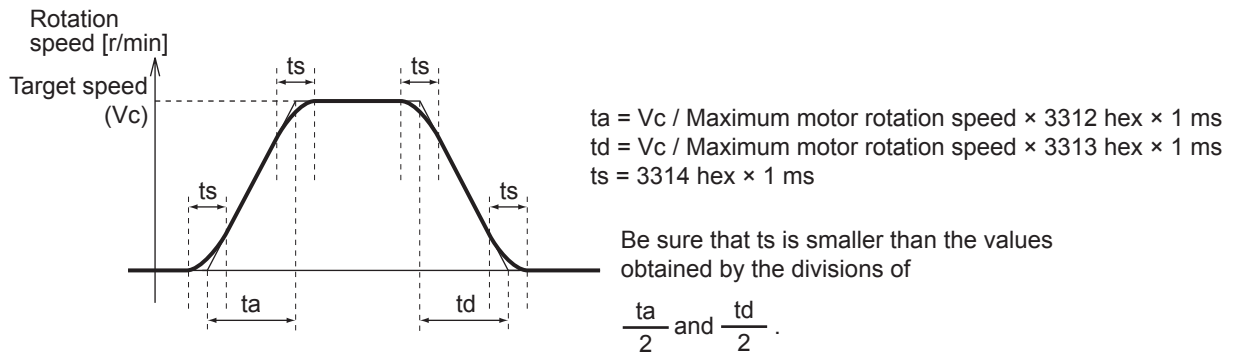

3317 hex	Speed Limit Selection						CST
Setting range	0 to 1	Unit	–	Default setting	1	Data attribute	B
Size	2 bytes (INT16)		Access	RW	PDO map	Not possible.	

- Select the speed limit.
- The speed limit is used as a protection during torque control.
- Refer to *6-3 Cyclic Synchronous Torque Mode* on page 6-8.

Explanation of Set Values

Set value	Description
0	Select the value set on the Speed Limit Value Setting (3321 hex).
1	Select either the speed limit value (VLIM) via EtherCAT communications or the value set by the Speed Limit Value Setting (3321 hex), whichever is smaller.

3321 hex	Speed Limit Value Setting						CST
Setting range	0 to 20000	Unit	r/min	Default setting	20000	Data attribute	A
Size	2 bytes (INT16)		Access	RW	PDO map	Not possible.	

- Set the speed limit value for torque control.
- It controls that the speed during torque control does not exceed the set value.
- Refer to *6-3 Cyclic Synchronous Torque Mode* on page 6-8.

3323 hex	External Feedback Pulse Type Selection						<input type="checkbox"/> csp (full)	<input type="checkbox"/> pp (full)	<input type="checkbox"/> hm (full)
Setting range	0 to 2	Unit	–	Default setting	0	Data attribute	R		
Size	2 bytes (INT16)		Access	RW	PDO map	Not possible.			

- Select the external encoder type. Be sure that the setting conforms to the external encoder which is actually used.
- Refer to 6-6 Fully-closed Control on page 6-16.

Explanation of Set Values

Set value	Description	Maximum input frequency ^{*1}
0	90° phase difference output type ^{*2*3}	0 to 4 Mpps (Multiplication × 4)
1	Serial communications type (Incremental encoder specifications) ^{*3}	0 to 400 Mpps
2	Serial communications type (Absolute encoder specifications) ^{*3}	0 to 400 Mpps

*1 The maximum input frequency is the feedback speed [pps] of the external encoder that can be processed by the Drive. Check the instruction manual of the external encoder for the maximum output frequency of the external encoder.

*2 These are the directions that the Drive counts a 90° phase difference output.

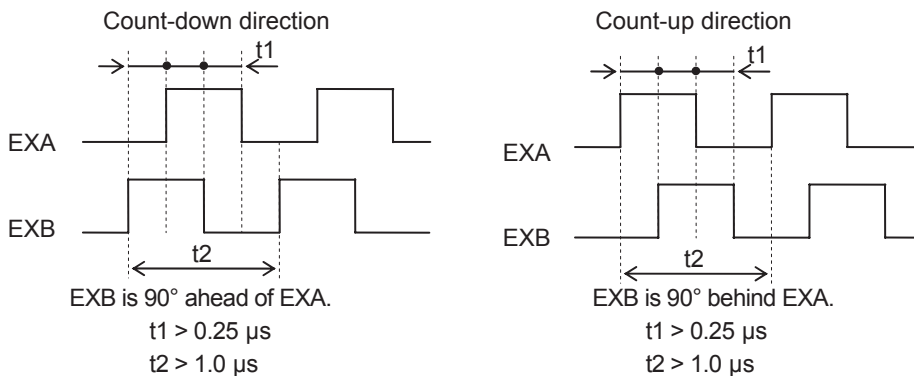

*3 For the external encoder connection direction, set the direction so that count-up occurs when the motor shaft is rotating in the CCW direction, and count-down occurs when the motor shaft is rotating in the CW direction. If the connection direction cannot be selected due to installation conditions, the count direction can be reversed using External Feedback Pulse Direction Switching (3326 hex).



Precautions for Correct Use

- If 3000 hex = 1, the encoder count direction will be opposite to the count direction used for monitoring the total external encoder feedback pulses. If 3000 hex = 0, the count direction matches the count direction for monitoring.
- Even when the speed command is within the Drive's speed command range, an acceleration error will occur if the speed command exceeds the maximum speed of motor shaft rotation.

3324 hex	External Feedback Pulse Dividing Numerator						<input type="checkbox"/> csp (full)	<input type="checkbox"/> pp (full)	<input type="checkbox"/> hm (full)
Setting range	0 to 1048576	Unit	–	Default setting	0	Data attribute	R		
Size	4 bytes (INT32)		Access	RW	PDO map	Not possible.			

3325 hex	External Feedback Pulse Dividing Denominator						<input type="checkbox"/> csp (full)	<input type="checkbox"/> pp (full)	<input type="checkbox"/> hm (full)
Setting range	1 to 1048576	Unit	–	Default setting	10000	Data attribute	R		
Size	4 bytes (INT32)		Access	RW	PDO map	Not possible.			

- Check the number of encoder pulses per motor rotation and number of external encoder pulses per motor rotation, and set External Feedback Pulse Dividing Numerator (3324 hex) and External Feedback Pulse Dividing Denominator (3325 hex).

$$\frac{3324 \text{ hex}}{3325 \text{ hex}} = \frac{\text{Encoder resolution per motor rotation [pulses]}}{\text{External encoder resolution per motor rotation [pulses]}}$$

- Set object 3324 hex to 0 to have the encoder resolution automatically set as the numerator.
- Refer to *6-6 Fully-closed Control* on page 6-16.



Precautions for Correct Use

- If this divider setting is wrong, there will be error between the position calculated from encoder pulses and the position calculated from external encoder pulses. If the movement distance is long, this error accumulates and causes a Excessive Hybrid Deviation Error (Error No. 25.0).
- The recommended divider setting is $1/40 \leq \text{External Feedback Pulse Ratio} \leq 160$. If the ratio is set too small, control to the unit of 1 external feedback pulse may be disabled. On the other hand, if the external feedback pulse ratio is increased, operating noise may increase.



Additional Information

In the example below, ball screw pitch is 10 mm, encoder is 0.1 μm/pulse, and encoder resolution is 20 bits (or 1,048,576 pulses)

$$\frac{3324 \text{ hex}}{3325 \text{ hex}} = \frac{\text{Encoder resolution per motor rotation [pulses]}}{\text{External encoder resolution per motor rotation [pulses]}} = \frac{1,048,576}{100,000}$$

3326 hex	External Feedback Pulse Direction Switching						<input type="checkbox"/> csp (full)	<input type="checkbox"/> pp (full)	<input type="checkbox"/> hm (full)
Setting range	0 to 1	Unit	–	Default setting	0	Data attribute	R		
Size	2 bytes (INT16)		Access	RW	PDO map	Not possible.			

- The direction of external encoder feedback count can be reversed.
- Refer to *6-6 Fully-closed Control* on page 6-16.

Explanation of Set Values

Set value	Description
0	External encoder feedback pulse count direction not reversed
1	External encoder feedback pulse count direction reversed

3327 hex	External Feedback Pulse Phase-Z Setting					csp (full)	pp (full)	hm (full)
Setting range	0 to 1	Unit	–	Default setting	0	Data attribute	R	
Size	2 bytes (INT16)		Access	RW	PDO map	Not possible.		

- Set to enable or disable phase-Z disconnection detection when an external encoder with a 90° phase difference output is used.

Explanation of Set Values

Set value	Explanation
0	Phase-Z disconnection detection enabled
1	Phase-Z disconnection detection disabled

3328 hex	Hybrid Following Error Counter Overflow Level					csp (full)	pp (full)	hm (full)
Setting range	1 to 134217728	Unit	Command unit	Default setting	16000	Data attribute	C	
Size	4 bytes (INT32)		Access	RW	PDO map	Not possible.		

- Set the allowable difference (feedback pulse error) between the motor (encoder) position and load (external encoder) position in command units.
- Refer to 6-6 *Fully-closed Control* on page 6-16.

3329 hex	Hybrid Following Error Counter Reset					csp (full)	pp (full)	hm (full)
Setting range	0 to 100	Unit	Rotation	Default setting	0	Data attribute	C	
Size	2 bytes (INT16)		Access	RW	PDO map	Not possible.		

- The feedback pulse error is reset every time the motor rotates for the amount set by the Hybrid Following Error Counter Reset (3329 hex). This can be used for applications where feedback pulse error accumulates due to slippage.
- Refer to 6-6 *Fully-closed Control* on page 6-16.

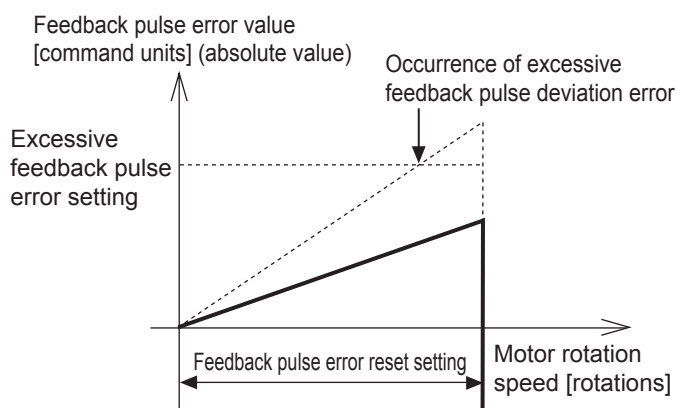

- Ensure that an appropriate value is set to the Hybrid Following Error Counter Reset (3329 hex), before you use the feedback pulse error counter reset. When the set value is extremely small, the protective function may not work to prevent any erroneous operation due to improper connection of the external encoder.



Precautions for Correct Use

- Provide sufficient safety measures. This includes mounting limit sensors.

9-5 Interface Monitor Settings

3400 hex	Input Signal Selection 1						<input type="button" value="All"/>
Setting range	0 to 00FF FFFF hex	Unit	–	Default setting	0094 9494 hex	Data attribute	C
Size	4 bytes (INT32)		Access	RW	PDO map	Not possible.	

- Set the function and logic for general-purpose input 1 (IN1).
- Refer to the Details of Control Inputs in *Control Input Details* on page 3-21, as well as *7-1 Sequence I/O Signals* on page 7-2.

3401 hex	Input Signal Selection 2						<input type="button" value="All"/>
Setting range	0 to 00FF FFFF hex	Unit	–	Default setting	0081 8181 hex	Data attribute	C
Size	4 bytes (INT32)		Access	RW	PDO map	Not possible.	

- Set the function and logic for general-purpose input 2 (IN2).
- Refer to the Details of Control Inputs in *Control Input Details* on page 3-21, as well as *7-1 Sequence I/O Signals* on page 7-2.

3402 hex	Input Signal Selection 3						<input type="button" value="All"/>
Setting range	0 to 00FF FFFF hex	Unit	–	Default setting	0082 8282 hex	Data attribute	C
Size	4 bytes (INT32)		Access	RW	PDO map	Not possible.	

- Set the function and logic for general-purpose input 3 (IN3).
- Refer to the Details of Control Inputs in *Control Input Details* on page 3-21, as well as *7-1 Sequence I/O Signals* on page 7-2.

3403 hex	Input Signal Selection 4						<input type="button" value="All"/>
Setting range	0 to 00FF FFFF hex	Unit	–	Default setting	0022 2222 hex	Data attribute	C
Size	4 bytes (INT32)		Access	RW	PDO map	Not possible.	

- Set the function and logic for general-purpose input 4 (IN4).
- Refer to the Details of Control Inputs in *Control Input Details* on page 3-21, as well as *7-1 Sequence I/O Signals* on page 7-2.

3404 hex	Input Signal Selection 5						<input type="button" value="All"/>
Setting range	0 to 00FF FFFF hex	Unit	–	Default setting	002B 2B2B hex	Data attribute	C
Size	4 bytes (INT32)		Access	RW	PDO map	Not possible.	

- Set the function and logic for general-purpose input 5 (IN5).
- Refer to the Details of Control Inputs in *Control Input Details* on page 3-21, as well as *7-1 Sequence I/O Signals* on page 7-2.

3405 hex	Input Signal Selection 6						<input type="button" value="All"/>
Setting range	0 to 00FF FFFF hex	Unit	–	Default setting	0021 2121 hex	Data attribute	C
Size	4 bytes (INT32)		Access	RW	PDO map	Not possible.	

- Set the function and logic for general-purpose input 6 (IN6).
- Refer to the Details of Control Inputs in *Control Input Details* on page 3-21, as well as *7-1 Sequence I/O Signals* on page 7-2.

3406 hex	Input Signal Selection 7						<input type="button" value="All"/>
Setting range	0 to 00FF FFFF hex	Unit	–	Default setting	0020 2020 hex	Data attribute	C
Size	4 bytes (INT32)		Access	RW	PDO map	Not possible.	

- Set the function and logic for general-purpose input 7 (IN7).
- Refer to the Details of Control Inputs in *Control Input Details* on page 3-21, as well as *7-1 Sequence I/O Signals* on page 7-2.

3407 hex	Input Signal Selection 8						<input type="button" value="All"/>
Setting range	0 to 00FF FFFF hex	Unit	–	Default setting	002E 2E2E hex	Data attribute	C
Size	4 bytes (INT32)		Access	RW	PDO map	Not possible.	

- Set the function and logic for general-purpose input 8 (IN8).
- Refer to the Details of Control Inputs in *Control Input Details* on page 3-21, as well as *7-1 Sequence I/O Signals* on page 7-2.

3410 hex	Output Signal Selection 1						<input type="button" value="All"/>
Setting range	0 to 00FF FFFF hex	Unit	–	Default setting	0003 0303 hex	Data attribute	C
Size	4 bytes (INT32)		Access	RW	PDO map	Not possible.	

- Set the function assignment for general-purpose output 1 (OUTM1).
- Refer to the Details of Control Outputs in *Control Output Details* on page 3-24, as well as *7-1 Sequence I/O Signals* on page 7-2.

3411 hex	Output Signal Selection 2						<input type="button" value="All"/>
Setting range	0 to 00FF FFFF hex	Unit	–	Default setting	0002 0202 hex	Data attribute	C
Size	4 bytes (INT32)		Access	RW	PDO map	Not possible.	

- Set the function assignment for general-purpose output 2 (OUTM2).
- Refer to the Details of Control Outputs in *Control Output Details* on page 3-24, as well as *7-1 Sequence I/O Signals* on page 7-2.

3416 hex	Analog Monitor 1 Selection						<input type="button" value="All"/>
Setting range	0 to 21	Unit	–	Default setting	0	Data attribute	A
Size	2 bytes (INT16)		Access	RW	PDO map	Not possible.	

- Analog signals of various monitor values can be output from the analog monitor connector on the front panel.
- The monitor type to output and the scaling (or output gain) can be selected. These can be set for each object.
- Refer to *11-1 Analog Monitor* on page 11-2.

Explanation of Set Values

Set value	Explanation		
	Monitor type	Unit	Output gain when object 3417 hex = 0
0	Feedback Motor Speed	r/min	500
1	Internal Command Motor Speed	r/min	500
2	Filtered Internal Command Motor Speed	r/min	500
3	Motor Control Effort	r/min	500
4	Torque demand	% (rated torque ratio)	33
5	Position Error	pulses (command units)	3000
6	Pulse Position Error	pulses (encoder units)	3000
7	Fully-closed error	pulses (external encoder units)	3000
8	Hybrid error	pulses (command units)	3000
9	P-N voltage	V	80
10	Regeneration load ratio	%	33
11	Motor load ratio	%	33
12	Forward External Torque Limit	% (rated torque ratio)	33
13	Reverse External Torque Limit	% (rated torque ratio)	33
14	Speed limit value	r/min	500
15	Inertia ratio	%	500
16 to 18	Reserved	–	–
19	Encoder temperature	°C	10
20	Servo Drive temperature	°C	10
21	Encoder 1-rotation data	pulses (encoder units)	110000

3417 hex	Analog Monitor 1 Scale Setting						<input type="button" value="All"/>
Setting range	0 to 214748364	Unit	–	Default setting	0	Data attribute	A
Size	4 bytes (INT32)		Access	RW	PDO map	Not possible.	

- Set the output gain for analog monitor 1.
- Refer to *11-1 Analog Monitor* on page 11-2.

3418 hex	Analog Monitor 2 Selection							<input type="button" value="All"/>
Setting range	0 to 21	Unit	–	Default setting	4	Data attribute	A	
Size	2 bytes (INT16)		Access	RW	PDO map	Not possible.		

- In the same way as for Analog Monitor 1, analog signals of various monitors can be output from the analog monitor connector on the front panel.
- Refer to the Analog Monitor 1 Selection (3416 hex) for the method to set this object.

3419 hex	Analog Monitor 2 Scale Setting							<input type="button" value="All"/>
Setting range	0 to 214748364	Unit	–	Default setting	0	Data attribute	A	
Size	4 bytes (INT32)		Access	RW	PDO map	Not possible.		

- Set the output gain for analog monitor 2.
- Refer to the Analog Monitor 1 Scale Setting (3417 hex) for the method to set this object.

3421 hex	Analog Monitor Output Selection							<input type="button" value="All"/>
Setting range	0 to 2	Unit	–	Default setting	0	Data attribute	A	
Size	2 bytes (INT16)		Access	RW	PDO map	Not possible.		

- Select the analog monitor output voltage direction.
- These are the output voltage range and the output direction when the Analog Monitor 1 Selection or Analog Monitor 2 Selection is set to the Feedback Motor Speed, and the Analog Monitor 1 Scale Setting or the Analog Monitor 2 Scale Setting is set to 0 (i.e., 1V = 500 r/min).

Set value	Output range	Data output
0	-10 to 10 V	
1	0 to 10 V	
2	0 to 10 V (5 V as a center)	

3432 hex	Positioning Completion Condition Selection						<input type="checkbox"/> csp	<input type="checkbox"/> pp	<input type="checkbox"/> hm
Setting range	0 to 3	Unit	–	Default setting	0	Data attribute	A		
Size	2 bytes (U16)		Access	RW	PDO map	Not possible.			

- Select the condition under which the positioning completion signal (INP1) is output.

Explanation of Set Value

Set value	Description
0	Turn ON when the position error is equal to or lower than 6067 hex (Position window).
1 to 3	Turn ON when there is no position command and the position error is equal to or lower than 6067 hex (Position window).

3433 hex	Positioning Completion Hold Time					<input type="checkbox"/> csp	<input type="checkbox"/> pp	<input type="checkbox"/> hm
Setting range	0 to 30000	Unit	ms	Default setting	0	Data attribute	A	
Size	2 bytes (U16)		Access	RW	PDO map	Not possible.		

- Set the hold time for when 3432 hex (Positioning Completion Condition Selection) is set to 3.

Explanation of Set Value

Set value	Description
0	The hold time will be an infinite time and the ON status will be held until the next position command is received.
1 to 30000	The ON status is held for the set time (ms). The output is turned OFF if a position command is received while the ON status is being held.

- The setting of this parameter does not affect the detection condition for the Target reached flag in 6041 hex (Statusword).

3434 hex	Zero Speed Detection					<input type="checkbox"/> All	
Setting range	10 to 20000	Unit	r/min	Default setting	50	Data attribute	A
Size	2 bytes (INT16)		Access	RW	PDO map	Not possible.	

- Set the output timing of the Zero Speed Detection Output (ZSP) as rotation speed [r/min].
- The Zero Speed Detection Output (ZSP) turns ON when the motor speed is lower than the set value of this object.
- The set value of this object is valid in both forward and reverse directions, regardless of the actual motor rotation direction. The setting has a hysteresis of 10 r/min.
- Refer to *Control Output Details* on page 3-24 for the Zero speed detection output (ZSP).

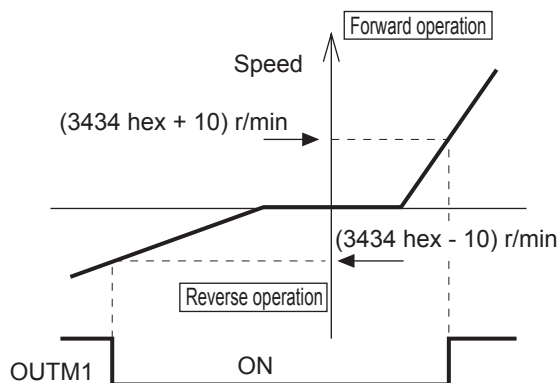

3435 hex	Speed Conformity Detection Range						CSV
Setting range	10 to 20000	Unit	r/min	Default setting	50	Data attribute	A
Size	2 bytes (INT16)		Access	RW	PDO map	Not possible.	

- It outputs the Speed conformity output (VCMP) when the speed command conforms to the motor speed.
- It is regarded as conformed when the difference between the speed command before the acceleration or deceleration process inside the Drive and the motor speed is smaller than the set value on the Speed Conformity Detection Range (3435 hex).
- The setting has a hysteresis of 10 r/min.
- Refer to the Control Output Details in *Control Output Details* on page 3-24 for the Speed conformity output (VCMP).

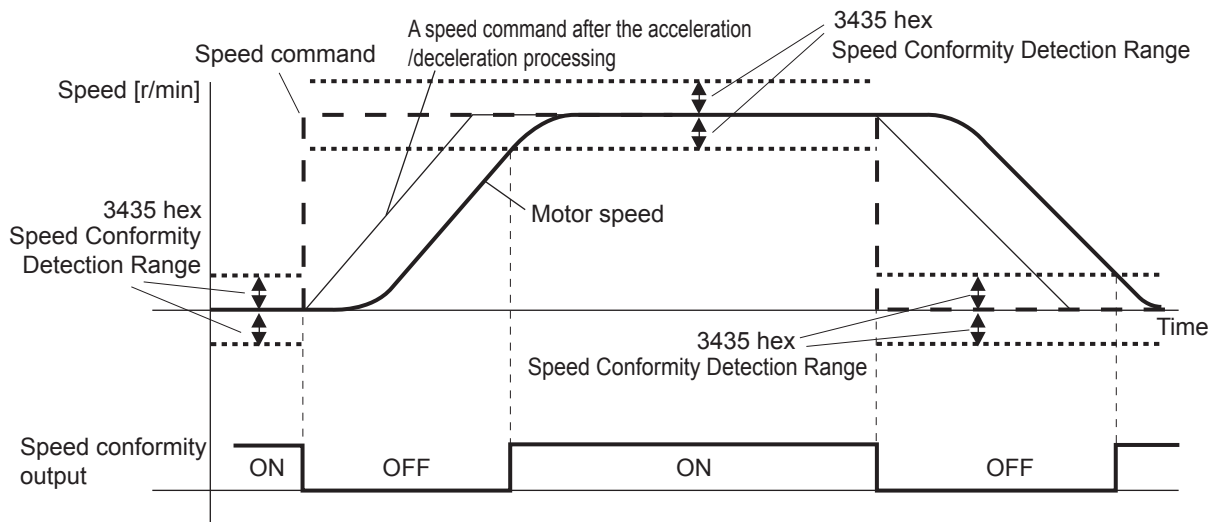

3436 hex	Rotation Speed for Motor Rotation Detection						CSV
Setting range	10 to 20000	Unit	r/min	Default setting	1,000	Data attribute	A
Size	2 bytes (INT16)		Access	RW	PDO map	Not possible.	

- It outputs the Motor rotation speed detection output (TGON) when the motor speed reaches the set arrival speed.
- The setting has a hysteresis of 10 r/min.
- Refer to the Control Output Details in *Control Output Details* on page 3-24 for the Motor rotation speed detection output (TGON).

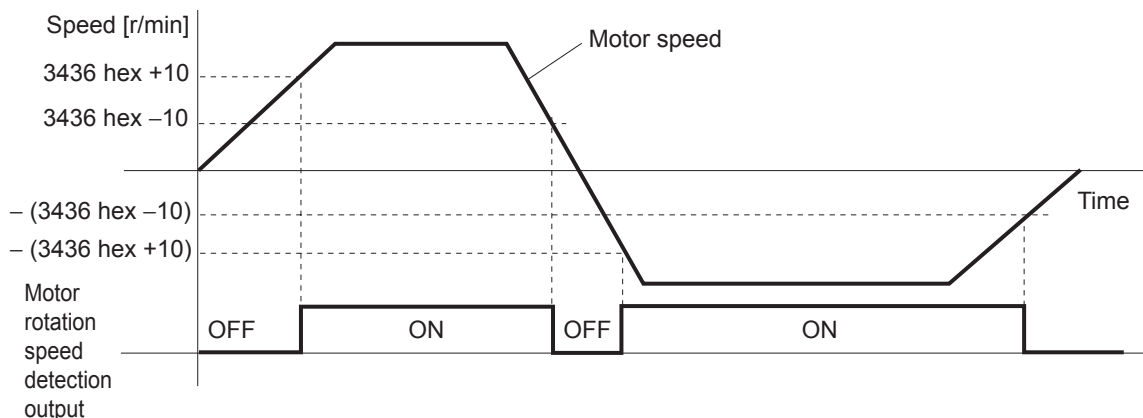

3437 hex	Brake Timing when Stopped						All
Setting range	0 to 10000	Unit	ms	Default setting	0	Data attribute	B
Size	2 bytes (INT16)		Access	RW	PDO map	Not possible.	

- Set the time required for the Servomotor to be de-energized (servo free) after the brake interlock output (BKIR) turns OFF (i.e., brake held), when servo OFF status is entered while the Servomotor is stopped.
- When the servo is turned OFF while the Servomotor is stopped, the brake interlock output (BKIR) turns ON, and the servo is de-energized after waiting for the set time (set value × ms).

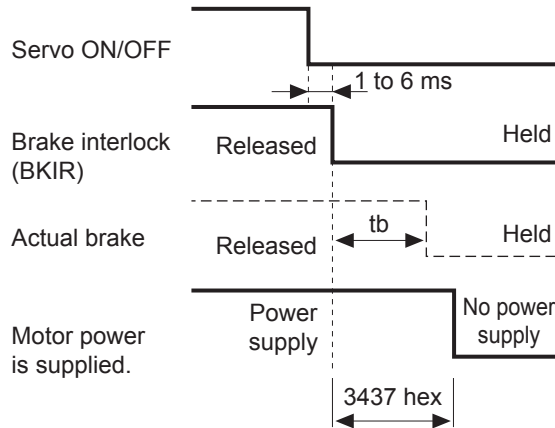

Make the setting as follows to prevent the machine (workpiece) from moving or falling due to the delay time in the brake operation (tb).

Brake timing when stopped (set value × 1 ms) ≥ tb

- For the operation time, refer to 7-5 Brake Interlock on page 7-15.

3438 hex	Brake Timing During Operation						All
Setting range	0 to 10000	Unit	ms	Default setting	0	Data attribute	B
Size	2 bytes (INT16)		Access	RW	PDO map	Not possible.	

- Set the required time for the Brake Interlock Output (BKIR) to turn OFF after the operation command (RUN) is detected to be OFF, when servo OFF status is entered while the Servomotor is operating. When the servo is turned OFF while the Servomotor is operating, the motor decelerates to reduce rotation speed, and the brake interlock output (BKIR) turns ON after the set time (set value × 1 ms) has elapsed.

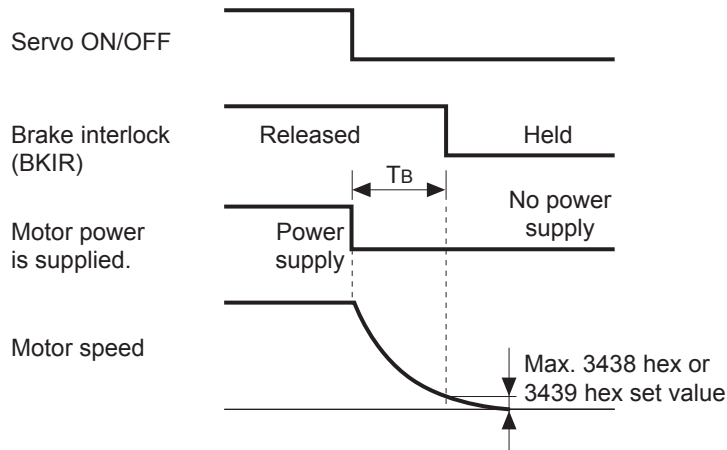

The time T_b in above drawing is either the brake timing during operation (i.e., the set value × 1 ms) or the time taken until it goes below the value set in the Brake Threshold Speed During Operation (3439 hex), whichever is shorter.

- For the operation time, refer to 7-5 Brake Interlock on page 7-15.

3439 hex	Brake Threshold Speed During Operation						All
Setting range	30 to 3000	Unit	r/min	Default setting	30	Data attribute	B
Size	2 bytes (INT16)		Access	RW	PDO map	Not possible.	

- Set the required rotation speed for the Brake Interlock Output (BKIR) to turn OFF after the servo OFF command is detected while the Servomotor is operating.
- For the operation time, refer to 7-5 Brake Interlock on page 7-15.

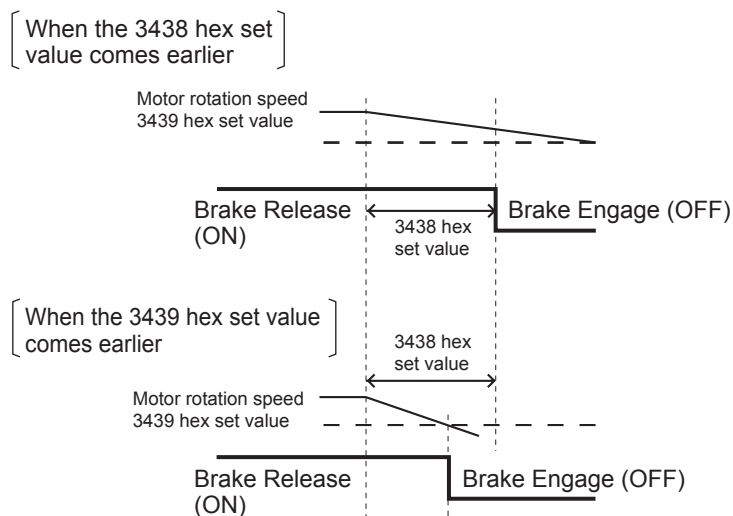

3440 hex	Warning Output Selection 1						<input type="button" value="All"/>	
Setting range	0 to 13	Unit	–	Default setting	0	Data attribute	A	
Size	2 bytes (INT16)		Access	RW	PDO map	Not possible.		

- Select the warning type to be output by Warning Output 1.
- Refer to *12-2 Warnings* on page 12-5.

Explanation of Set Values

Set value	Description
0	Output by all types of warnings
1	Overload warning
2	Excessive regeneration warning
3	Battery warning
4	Fan warning
5	Encoder communications warning
6	Encoder overheating warning
7	Vibration warning
8	Service life warning
9	External encoder error warning
10	External encoder communications error warning
11	Data setting warning
12	Command warning
13	EtherCAT communications warning

3441 hex	Warning Output Selection 2						<input type="button" value="All"/>	
Setting range	0 to 13	Unit	–	Default setting	0	Data attribute	A	
Size	2 bytes (INT16)		Access	RW	PDO map	Not possible.		

- Select the warning type to be output by Warning Output 2.
- Refer to the Warning Output Selection 1 (3440 hex) for the object setting method.
- Refer to *12-2 Warnings* on page 12-5.

3442 hex	Positioning Completion Range 2						<input type="button" value="csp"/> <input type="button" value="pp"/> <input type="button" value="hm"/>	
Setting range	0 to 262144	Unit	Command unit	Default setting	10	Data attribute	A	
Size	4 bytes (INT32)		Access	RW	PDO map	Not possible.		

- Set the positioning completion range to output Positioning Completion Output 2 (INP2).
- The Positioning Completion Output 2 (INP2) is not affected by the position commands. It is ON as long as the position error is below the set value.
- The setting unit is command units. It can be changed to encoder units by the Position Setting Unit Selection (3520 hex). However, note that the unit for the Following error window (6065 hex) will change as well.

9-6 Extended Objects

3504 hex	Drive Prohibition Input Selection						All
Setting range	0 to 2	Unit	–	Default setting	1	Data attribute	C
Size	2 bytes (INT16)		Access	RW	PDO map	Not possible.	

- Set the operation of the Forward Drive Prohibition Input (POT) and the Reverse Drive Prohibition Input (NOT).
- Refer to *7-2 Forward and Reverse Drive Prohibition Functions* on page 7-8.

Explanation of Set Values

Set value	Explanation
0	An error will occur if both the forward and reverse drive prohibition inputs are open at the same time.
1	Forward drive prohibition input and reverse drive prohibition input disabled.
2	An error will occur if either the forward or the reverse drive prohibition input is open.

- Install limit switches at both ends of the axis to prohibit the motor from traveling in the direction where one of the switches operates. This can be used to prevent the workpiece from traveling too far and thus prevent damage to the machine.
- When the object is set to 0, the operation is as follows:
 - Forward Drive Prohibition Input (POT) closed: Forward limit switch not operating and status normal.
 - Forward Drive Prohibition Input (POT) open: Forward direction prohibited and reverse direction permitted.
 - Reverse Drive Prohibition Input (NOT) closed: Reverse limit switch not operating and status normal.
 - Reverse Drive Prohibition Input (NOT) open: Reverse direction prohibited and forward direction permitted.
- If this object is set to 0, the Servomotor decelerates and stops according to the sequence set in the Stop Selection for Drive Prohibition Input (3505 hex). For details, refer to explanation for Stop Selection for Drive Prohibition Input (3505 hex).



Precautions for Correct Use

- If this object is set to 0 and the forward and reverse prohibition inputs are both open, a Drive Prohibition Input Error (Error No. 38.0) will occur because it is taken that Servo Drive is in error condition.
- If this object is set to 2, a Drive Prohibition Input Error (Error No. 38.0) will occur when the connection between either the forward or reverse prohibition input and COM is open.
- If a limit switch above the workpiece is turned OFF when using a vertical axis, the upward torque decreases, and there may be repeated vertical movement of the workpiece. If this occurs, set the Stop Selection for Drive Prohibition Input (3505 hex) to 2 or perform limit processing using the host controller.

3505 hex	Stop Selection for Drive Prohibition Input						<input type="button" value="All"/>
Setting range	0 to 2	Unit	–	Default setting	0	Data attribute	C
Size	2 bytes (INT16)		Access	RW	PDO map	Not possible.	

- Set the drive conditions during deceleration and after stopping, when the Forward or Reverse Drive Prohibition Input is enabled.
- Refer to 7-2 *Forward and Reverse Drive Prohibition Functions* on page 7-8.

Explanation of Set Values

Set value of 3504 hex ^{*1}	Set value of 3505 hex	Decelerating ^{*2}		After stopping
		Deceleration method	Error counter	Operation after stopping
0	0	Dynamic brake	Cleared	Torque command in drive-prohibited direction = 0
	1	Free-run	Cleared	Torque command in drive-prohibited direction = 0
	2	Immediate stop ^{*3}	Cleared	The torque command and torque limits will be as specified.

*1 If the Drive Prohibition Input Selection (3504 hex) is set to 2, a Drive Prohibition Input Error (Error No. 38.0) will occur as soon as either the Forward or Reverse Drive Prohibition Input turns ON. The subsequent operation conforms not to the set value, but to the setting of the Fault reaction option code (605E hex). In the same way, the Fault reaction option code (605E hex) takes priority when any other error occurs.

*2 The term “During deceleration” means the distance until the motor decreases its speed to 30 r/min or less from the normal operation. Once it decelerates to 30 r/min or lower speed, the operation conforms to the description for “after stopping”, regardless of the actual speed.

*3 “Immediate Stop” means that the Servomotor stops immediately by using controls while the servo is kept ON. The torque limit at this time is controlled by the Immediate Stop Torque (3511 hex) set value.



Precautions for Correct Use

- At an immediate stop, an Error Counter Overflow Error (Error No. 24.0) or an Overrun Limit Error (Error No. 34.0) may occur. This is because the immediate stop forces the motor to decelerate quickly, and the position control creates a large position error momentarily. If an error occurs, set the Following error window (6065 hex) and the Overrun Limit Setting (3514 hex) to appropriate values.
- A Command Warning (Warning No. B1 hex) will occur if a command is given in the drive prohibition direction while the Servomotor is stopped (or decreased the speed to 30 r/min or lower) and the Drive Prohibition Input is ON.

3508 hex	Undervoltage Error Selection						<input type="button" value="All"/>
Setting range	0 to 1	Unit	–	Default setting	1	Data attribute	B
Size	2 bytes (INT16)		Access	RW	PDO map	Not possible.	

- Select whether to turn OFF the servo or stop operation with an error when the main circuit power supply is shut OFF.

Explanation of Set Values

Set value	Explanation
0	The servo is turned OFF based on the setting of the Shutdown option code (605B hex). The servo is then turned back ON when the main power supply is turned ON.
1	A Main Power Supply Undervoltage Error (Error No. 13.1) occurs and operation stops.

3509 hex	Momentary Hold Time						<input type="button" value="All"/>	
Setting range	70 to 2000	Unit	ms	Default setting	70	Data attribute	C	
Size	2 bytes (INT16)		Access	RW	PDO map	Not possible.		

- Set the Main Power Supply Undervoltage Error detection time.
- The main power supply OFF detection is disabled if this object is set to 2000.

3511 hex	Immediate Stop Torque						<input type="button" value="All"/>	
Setting range	0 to 5000	Unit	0.1%	Default setting	0	Data attribute	B	
Size	2 bytes (INT16)		Access	RW	PDO map	Not possible.		

- Set the torque limit for immediate stops.
- Set the torque limit for the following cases.
 - Drive prohibition deceleration with the Stop Selection for Drive Prohibition Input (3505 hex) set to 2.
 - When decelerating and the Disable operation option code (605C hex) is -5 or -4
 - When decelerating and the Shutdown option code (605B hex) is -5 or -4
- The normal torque limit is applied if this object is set to 0.
- Set the value in units of 1% of the rated torque (100%).

3512 hex	Overload Detection Level Setting						<input type="button" value="All"/>	
Setting range	0 to 500	Unit	%	Default setting	0	Data attribute	A	
Size	2 bytes (INT16)		Access	RW	PDO map	Not possible.		

- Set the overload detection level.
- When the object is set to 0, the setting is 115%.
- If 115 or higher is set, a value of 115% will be used.
- Set the value in units of 1% of the rated torque (100%).

3513 hex	Overspeed Detection Level Setting						<input type="button" value="All"/>	
Setting range	0 to 20000	Unit	r/min	Default setting	0	Data attribute	A	
Size	2 bytes (INT16)		Access	RW	PDO map	Not possible.		

- Set the overspeed detection level.
- The overspeed detection level setting is 1.2 times the maximum motor rotation speed if this object is set to 0.
- This object should normally be set to 0. The setting should be changed only when it is necessary to lower the overspeed detection level.
- The set value of this object is limited to 1.2 times the maximum motor rotation speed.
- The detection margin of error for the set value is ± 3 r/min for a 5-core absolute encoder and ± 36 r/min for a 5-core incremental encoder.

3514 hex	Overrun Limit Setting						<input type="button" value="csp"/> <input type="button" value="pp"/> <input type="button" value="hm"/>	
Setting range	0 to 1000	Unit	0.1 rotation	Default setting	10	Data attribute	A	
Size	2 bytes (INT16)		Access	RW	PDO map	Not possible.		

- Set the allowable operating range for the position command input range.
- If the set value is exceeded, and Overrun Limit Error (Error No. 34.0) will occur.
- Refer to *7-3 Overrun Protection* on page 7-11.

3515 hex	Control Input Signal Read Setting						<input type="checkbox"/> All	
Setting range	0 to 3	Unit	–	Default setting	0	Data attribute	C	
Size	2 bytes (INT16)		Access	RW	PDO map	Not possible.		

- Select the signal read cycle for control input (digital input).
- The External Latch Inputs 1, 2 and 3 (EXT1, 2, and 3) are excluded.
- The Servo Drive reads an input signal multiple times at the specified cycle. If the Servo Drive reads the same signal for multiple consecutive cycles, then the input signal is valid.

Explanation of Set Values

Set value	Description
0	0.250 ms
1	0.500 ms
2	1.5 ms
3	2.5 ms

3520 hex	Position Setting Unit Selection						<input type="checkbox"/> csp <input type="checkbox"/> pp <input type="checkbox"/> hm	
Setting range	0 to 1	Unit	–	Default setting	0	Data attribute	C	
Size	2 bytes (INT16)		Access	RW	PDO map	Not possible.		

- Select the setting unit of Position Completion Range 2 (3442 hex) and Following error window (6065 hex).

Explanation of Set Values

Set value	Description
0	Command units
1	Encoder units (External encoder units)



Precautions for Correct Use

- Detection of the Positioning Completed status in EtherCAT communications is always performed using command units, regardless of the setting on this object.
- Normally, use the default setting of 0 (command units).

3521 hex	Torque Limit Selection						<input type="button" value="All"/>
Setting range	0 to 7	Unit	–	Default setting	6	Data attribute	B
Size	2 bytes (INT16)		Access	RW	PDO map	Not possible.	

- Select the method to set the forward and reverse torque limits.
- Refer to *7-7 Torque Limit Switching* on page 7-24.

Explanation of Set Values

Set value	Position control/speed control/torque control/fully-closed control			
	Positive torque limit value ^{*1}		Negative torque limit value ^{*2}	
	PCL ON	PCL OFF	NCL ON	NCL OFF
0,1	3013 hex			
2	3013 hex		3522 hex	
3	3522 hex	3013 hex	3522 hex	3013 hex
4	60E0 or 3013 hex ^{*3}		60E1 or 3522 hex ^{*4}	
5	60E0 or 3013 hex ^{*3}	3013 hex	60E1 or 3522 hex ^{*4}	3522 hex
6	3525 hex	60E0 or 3013 hex ^{*3}	3526 hex	60E1 or 3522 hex ^{*4}
7	3013 hex	3525 hex	3522 hex	3526 hex

*1 PCL ON is the state in which either the external input signal (PCL) or the EtherCAT communications torque control command (P-CL) is ON; PCL OFF is the state in which both of these are OFF.

*2 NCL ON is the state in which either the external input signal (NCL) or the EtherCAT communications torque control command (N-CL) is ON; NCL OFF is the state in which both of these are OFF.

*3 The smaller of 60E0 hex or 3013 hex is used.

*4 The smaller of 60E1 hex or 3522 hex is used.

- When this object is set to 0 or 1, the Forward and Reverse Torque Limit Inputs are restricted by the Positive torque limit value (60E0 hex).



Precautions for Correct Use

For the torque limit parameters, the objects that are specified are different for an R88D-KN□□□-ECT-R Servo Drive. Refer to the *G5 AC Servomotors/Servo Drives User's Manual* (Cat. No. I573) for details on R88D-KN□□□-ECT-R objects.

3522 hex	External Torque Limit 2						All
Setting range	0 to 5000	Unit	0.1%	Default setting	5000 ^{*1}	Data attribute	B
Size	2 bytes (INT16)		Access	RW	PDO map	Not possible.	

*1 It is limited by the maximum torque of the connected motor.

- Set the limit value for the output torque (3013 hex: External Torque Limit 1, 3522 hex: External Torque Limit 2) of the motor.
- Refer to information on the Torque Limit Selection (3521 hex) to select the torque limits.
- During torque control, maximum torques for both forward and reverse directions are limited. Settings in Torque Limit Selection (3521 hex) and External Torque Limit 2 (3522 hex) is ignored.
- Make the settings as a percentage of the rated torque.
[Example] Maximum torque is limited to 150%

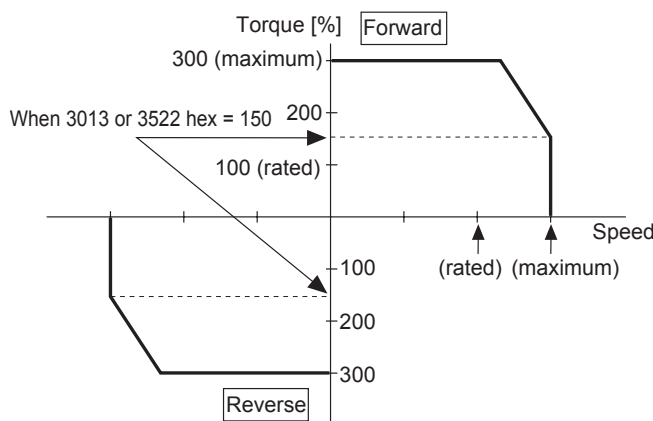

- Refer to 7-7 *Torque Limit Switching* on page 7-24 for more information on torque limits and the torque limit selection.

3525 hex	Forward External Torque Limit						All
Setting range	0 to 5000	Unit	0.1%	Default setting	5000 ^{*1}	Data attribute	B
Size	2 bytes (INT16)		Access	RW	PDO map	Not possible.	

*1 It is limited by the maximum torque of the connected motor.

- Set the forward external torque limit for the torque limit switching input.
- Set the value in units of 0.1% of the rated torque (100%).

3526 hex	Reverse External Torque Limit						All
Setting range	0 to 5000	Unit	0.1%	Default setting	5000 ^{*1}	Data attribute	B
Size	2 bytes (INT16)		Access	RW	PDO map	Not possible.	

*1 It is limited by the maximum torque of the connected motor.

- Set the reverse external torque limit for the torque limit switching input.
- Set the value in units of 0.1% of the rated torque (100%).

9-7 Special Objects

3602 hex	Excessive Speed Error Setting						<input type="checkbox"/> csp (semi)	<input type="checkbox"/> pp (semi)	<input type="checkbox"/> hm (semi)
Setting range	0 to 20000	Unit	r/min	Default setting	0	Data attribute	B		
Size	2 bytes (INT16)		Access	RW	PDO map	Not possible.			

- Set the value for an Excessive Speed Deviation Error (Error No. 24.1).
If the set value is 0, excessive speed errors will not be detected.

3605 hex	Gain 3 Effective Time						<input type="checkbox"/> csp
Setting range	0 to 10000	Unit	0.1 ms	Default setting	0	Data attribute	B
Size	2 bytes (INT16)		Access	RW	PDO map	Not possible.	

- Set effective time of gain 3 of 3-step gain switching.
- Refer to *7-10 Gain Switching 3 Function* on page 7-38.

3606 hex	Gain 3 Ratio Setting						<input type="checkbox"/> csp
Setting range	50 to 1000	Unit	%	Default setting	100	Data attribute	B
Size	2 bytes (INT16)		Access	RW	PDO map	Not possible.	

- Set gain 3 as a multiple of gain 1.
- Refer to *7-10 Gain Switching 3 Function* on page 7-38.

3607 hex	Torque Command Value Offset						<input type="checkbox"/> All
Setting range	-100 to 100	Unit	%	Default setting	0	Data attribute	B
Size	2 bytes (INT16)		Access	RW	PDO map	Not possible.	

- Set the offset torque to add to torque commands.
- Refer to *11-9 Friction Torque Compensation Function* on page 11-28.
- Set the value in units of 1% of the rated torque (100%).

3608 hex	Forward Direction Torque Offset						<input type="checkbox"/> All
Setting range	-100 to 100	Unit	%	Default setting	0	Data attribute	B
Size	2 bytes (INT16)		Access	RW	PDO map	Not possible.	

- Set the value to add to a torque command for forward operation.
- Refer to *11-9 Friction Torque Compensation Function* on page 11-28.
- Set the value in units of 1% of the rated torque (100%).

3609 hex	Reverse Direction Torque Offset						<input type="checkbox"/> All
Setting range	-100 to 100	Unit	%	Default setting	0	Data attribute	B
Size	2 bytes (INT16)		Access	RW	PDO map	Not possible.	

- Set the value to add to a torque command for reverse operation.
- Refer to *11-9 Friction Torque Compensation Function* on page 11-28.
- Set the value in units of 1% of the rated torque (100%).

3610 hex	+Function Expansion Setting						All
Setting range	0 to 127	Unit	–	Default setting	64	Data attribute	B
Size	2 bytes (INT16)		Access	RW	PDO map	Not possible.	

- Set the functions by bit.
- Set the decimal value that has been converted from the bits.
- In the default settings, only the command compensation for communications errors for CSP is enabled. The number 64 decimal is 1000 000 when represented as bits.
- Refer to *11-8 Disturbance Observer Function* on page 11-26 and *11-12 Instantaneous Speed Observer Function* on page 11-34.

Bit	Function	Set value	
		0	1
bit 0	Instantaneous speed observer function	Disabled	Enabled
bit 1	Disturbance observer function	Disabled	Enabled
bit 2	Disturbance observer operation setting	Enabled at all time	Only when gain 1 is selected
bit 3	Reserved for manufacturer use	Fixed to 0.	
bit 4	Electric current response improvement function	Disabled	Enabled
bit 5	Reserved for manufacturer use	Fixed to 0.	
bit 6	Command compensation for communications errors for CSP	Disabled	Enabled

- If the command compensation for communications errors for CSP is enabled and a communications error occurs, the Servo Drive will compensate and control the internal command based on the value of the Target position (607A hex) that was most recently received normally.

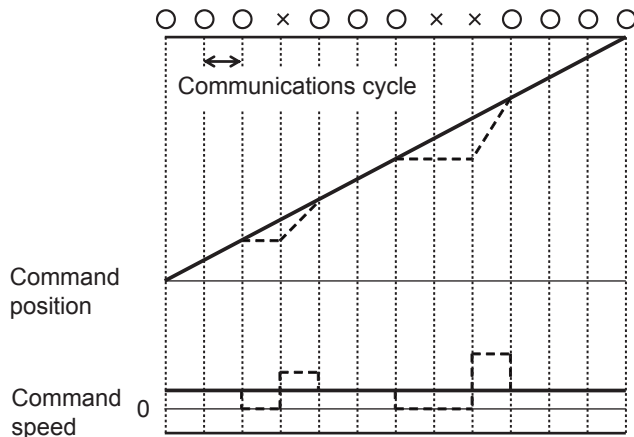

- Solid line: Command compensation enabled.
- Dashed line: Command compensation disabled.
- ○: Normal communications
- ×: Communications error

**Additional Information****Example**

- Instantaneous speed observer function: enabled
 - Disturbance observer function: enabled
 - Disturbance observer operation setting: enabled at all time
 - Electric current response improvement function: enabled
 - Command compensation for communications errors for CSP: Disabled
- If the settings are as described above, the bit will be 0010011, and the decimal value 19. Therefore, the set value will be 19.

3611 hex	Electric Current Response Setting						All
Setting range	50 to 100	Unit	%	Default setting	100	Data attribute	B
Size	2 bytes (INT16)		Access	RW	PDO map	Not possible.	

- Make fine adjustment to electric current response. The default setting is 100%.

3614 hex	Error Detection Allowable Time Setting						All
Setting range	0 to 1000	Unit	ms	Default setting	200	Data attribute	B
Size	2 bytes (INT16)		Access	RW	PDO map	Not possible.	

- Set the allowable time until stopping if an immediate stop is executed when an error is detected.
- When the time exceeds the set value, the operation forcibly turns to an error state.
- When the object is set to 0, the protection for the allowable time does not function.
- Refer to the *Immediate Stop Operation* on page 12-13.

3615 hex	Overspeed Detection Level Setting at Immediate Stop						All
Setting range	0 to 20000	Unit	r/min	Default setting	0	Data attribute	A
Size	2 bytes (INT16)		Access	RW	PDO map	Not possible.	

- If the motor speed exceeds the set value during an immediate stop resulting from an error, an Overspeed 2 Error (Error No. 26.1) will occur.
- The overspeed detection level setting is 1.2 times the maximum motor rotation speed if this object is set to 0.
- This object should normally be set to 0. The setting should be changed only when it is necessary to lower the overspeed detection level.
- Refer to *Immediate Stop Operation* on page 12-13.

3618 hex	Power Supply ON Initialization Time						All
Setting range	0 to 100	Unit	0.1 s	Default setting	0	Data attribute	R
Size	2 bytes (INT16)		Access	RW	PDO map	Not possible.	

- Set the initialization time after turning ON the power supply to the standard 1.5 seconds plus the specified value.
- Refer to the Control Output Sequence in *3-1 Servo Drive Specifications* on page 3-2 for the details at power ON.

3623 hex	Disturbance Torque Compensation Gain						<input type="checkbox"/> csp (semi)	<input type="checkbox"/> csv	<input type="checkbox"/> pp (semi)	<input type="checkbox"/> hm (semi)
Setting range	-100 to 100	Unit	%	Default setting	0	Data attribute	B			
Size	2 bytes (INT16)		Access	RW	PDO map	Not possible.				

- Set the compensation gain for the disturbance torque.
- Refer to *11-8 Disturbance Observer Function* on page 11-26.

3624 hex	Disturbance Observer Filter Setting						<input type="checkbox"/> csp (semi)	<input type="checkbox"/> csv	<input type="checkbox"/> pp (semi)	<input type="checkbox"/> hm (semi)
Setting range	10 to 2500	Unit	0.01 ms	Default setting	53	Data attribute	B			
Size	2 bytes (INT16)		Access	RW	PDO map	Not possible.				

- Set the filter time constant for disturbance torque compensation.
- Refer to *11-8 Disturbance Observer Function* on page 11-26.

3631 hex	Realtime Autotuning Estimated Speed Selection						<input type="checkbox"/> All			
Setting range	0 to 3	Unit	–	Default setting	0	Data attribute	B			
Size	2 bytes (INT16)		Access	RW	PDO map	Not possible.				

- Set the speed to estimate the load characteristic while the realtime autotuning is enabled.
- The higher the set value is, the earlier the load characteristic change is followed, but the estimated variation against the disturbance becomes greater.
- The estimated results is updated in every 30 minutes and saved in EEPEOM.
- Refer to *11-3 Realtime Autotuning* on page 11-7.

Explanation of Set Values

Set value	Mode	Description
0	No change	Stops load estimation.
1	Little change	Estimates every minute from the load characteristic changes.
2	Gradual change	Estimates every second from the load characteristic changes.
3	Sharp change	Estimates the optimum from the load characteristic changes.

3632 hex	Realtime Autotuning Customization Mode Setting						All
Setting range	-32768 to 32767	Unit	–	Default setting	0	Data attribute	B
Size	2 bytes (INT16)		Access	RW	PDO map	Not possible.	

- Set the details of the autotuning function when the Realtime Autotuning Mode Selection (3002 hex) is set to 6.
- Refer to *11-3 Realtime Autotuning* on page 11-7.

Explanation of Set Values

Bit	Name	Description
0 to 1	Load characteristic estimation ^{*1}	Select to enable or disable load characteristic estimation. 0: Disable 1: Enable
2 to 3	Inertia ratio updating	Select whether to update the present set value of the Inertial Ratio (3004 hex) with the load characteristic estimation result. 0: Use the present set value. 1: Update with the estimation result.
4 to 6	Torque compensation	Select whether to update three objects, Torque Command Value Offset (3607 hex), Forward Direction Torque Offset (3608 hex), and Reverse Direction Torque Offset (3609 hex), with the load characteristic estimation result. 0: Use the present set value. 1: Disable the torque compensation. Clear the above three objects to zero. 2: Vertical mode. Update 3607 hex. Clear 3608 hex and 3609 hex to zero. 3: Friction compensation (small). Update 3607 hex. Set a small compensation to 3608 hex and 3609 hex. 4: Friction compensation (intermediate). Update 3607 hex. Set an intermediate compensation in 3608 hex and 3609 hex. 5: Friction compensation (large). Update 3607 hex. Set a large compensation in 3608 hex and 3609 hex.
7	Rigidity setting	Select to enable or disable the basic gain setting by the Realtime Autotuning Machine Rigidity Setting (3003 hex). 0: Disable 1: Enable
8	Fixed object settings	Select whether to allow changes to the objects that normally are fixed. 0: Use the present settings. 1: Set to fixed values.
9 to 10	Gain switch setting	Select the method to set the objects that relate to gain switching while the realtime autotuning is enabled. 0: Use the present settings. 1: Disable gain switching. 2: Enable gain switching.

*1 When load characteristic estimation is disabled, inertial ratio updating is also disabled, even if the latter is set to be updated with the estimation result. When torque compensation is updated with the estimation result, load characteristic estimation is disabled.



Precautions for Safe Use

- This object must be set in units of bits. Users must be fully aware that proper operation of your system is not guaranteed, if you have incorrect object settings. Pay a particular attention when you set them.



Additional Information

Procedure to Set the Object Bit by Bit

Follow these steps and calculate the set values, when you make any setting other than 0.

- (1) Confirm the least significant bit (LSB) in each set value.
E.g. LSB of Torque compensation function: 4
- (2) Multiply the set value by 2 to the power of the bit number of the LSB.
E.g. To set the torque compensation to Friction compensation (small): The set value is 3. The exponent is 4.

$$2^4 \times 3 = 48$$

- (3) Repeat Step (1) and (2) for all bit settings. Add all results and set the outcome to 3632 hex.

E.g. When all of the Load characteristic estimation, the Inertia ratio updating, the Rigidity setting, and the Gain switch setting are enabled, the Torque compensation is set to Friction compensation (small), and the Fixed object setting is set to a Fixed value:

$$2^0 \times 1 + 2^2 \times 1 + 2^4 \times 3 + 2^7 \times 1 + 2^8 \times 1 + 2^9 \times 2 = 1461$$

3634 hex	Hybrid Vibration Suppression Gain						<input type="text" value="csp (semi)"/> <input type="text" value="pp (semi)"/> <input type="text" value="hm (semi)"/>	
Setting range	0 to 30000	Unit	0.1/s	Default setting	0	Data attribute	B	
Size	2 bytes (INT16)		Access	RW	PDO map	Not possible.		

- Set the hybrid vibration suppression gain during fully-closed control.
- In general, set it to the same value as the position loop gain, and finely adjust it based on the situation.
- Refer to *11-10 Hybrid Vibration Suppression Function* on page 11-30.

3635 hex	Hybrid Vibration Suppression Filter						<input type="text" value="csp (semi)"/> <input type="text" value="pp (semi)"/> <input type="text" value="hm (semi)"/>	
Setting range	0 to 6400	Unit	0.01 ms	Default setting	10	Data attribute	B	
Size	2 bytes (INT16)		Access	RW	PDO map	Not possible.		

- Set the hybrid vibration suppression filter.
- Refer to *11-10 Hybrid Vibration Suppression Function* on page 11-30.

3637 hex	Vibration Detection Threshold						<input type="text" value="All"/>	
Setting range	0 to 1000	Unit	0.1%	Default setting	0	Data attribute	B	
Size	2 bytes (INT16)		Access	RW	PDO map	Not possible.		

- Set the vibration detection threshold.
- If torque vibration that exceeds this setting is detected, a vibration detection warning occurs.
- Refer to *12-2 Warnings* on page 12-5.
- Set the value in units of 0.1% of the rated torque (100%).

3638 hex	Warning Mask Setting						<input type="checkbox"/> All
Setting range	-32768 to 32767	Unit	–	Default setting	4	Data attribute	C
Size	2 bytes (INT16)		Access	RW	PDO map	Not possible.	

- Set the warning detection mask setting.
- If you set the corresponding bit to 1, the corresponding warning detection is disabled.
- Refer to the *General Warnings* on page 12-6.

Warning number	Warning name	Warning condition	Warning Mask Setting (3638 hex) *1
A0	Overload warning	The load ratio is 85% or more of the protection level.	Bit 7
A1	Excessive regeneration warning	The regeneration load ratio is 85% or more of the level.	Bit 5
A2	Battery warning	Battery voltage is 3.2 V or less.	Bit 0
A3	Fan warning	The fan stops for 1 second.	Bit 6
A4	Encoder communications warning	Encoder communications errors occurred in series more than the specified value.	Bit 4
A5	Encoder overheating warning	The encoder temperature exceeded the specified value.	Bit 3
A6	Vibration detection warning	Vibration is detected.	Bit 9
A7	Life expectancy warning	The life expectancy of the capacitor or the fan is shorter than the specified value.	Bit 2
A8	External encoder error warning	The external encoder detects a warning.	Bit 8
A9	External encoder communications warning	The external encoder has more communications errors in series than the specified value.	Bit 10

*1 Each warning detection can be masked with the Warning Mask Setting (3638 hex). The table above shows the corresponding bits. When a bit is set to 1, the warning detection is masked.

3700 hex	LED Display Selection						<input type="text" value="All"/>
Setting range	0 to 32767	Unit	–	Default setting	0	Data attribute	A
Size	2 bytes (INT16)		Access	RW	PDO map	Not possible.	

- Select a data type to display on the 7-segment display on the front panel.

Explanation of Set Value

Set value	Indicated item	Description
0	Normal state	Displays “– –” during Servo-OFF, and “00” during Servo ON.
1	Mechanical angle	Displays a value between 0 and FF hex. The value 0 indicates the zero position of the encoder. The value increments when the motor rotates in the counterclockwise (CCW) direction. The value returns to 0 when it exceeds FF, but the count continues. When an incremental encoder is used, it indicates “nF” (i.e., not fixed) is displayed until the zero position of the encoder is detected after the control power is turned ON.
2	Electric angle	Displays a value between 0 and FF hex. The value 0 indicates the position when the U-phase electro-motive force shows the positive peak. The value increments when the motor rotates in the counterclockwise (CCW) direction. The value returns to 0 when it exceeds FF, but the count continues.
3	Total number of EtherCAT communications errors ^{*1}	Displays a value between 0 and FF hex. The cumulative count is saturated when it reaches the maximum value (FFFF hex). In this case, only the lowest order byte is shown. The value returns to 00 when it exceeds FF, but the count continues.
4	Rotary switch setting (node address)	Displays the rotary switch setting (i.e. node address) read at power-ON. The displayed value is in decimal. The value is not altered by any changes to the rotary switch setting after the power-ON.
5	Total number of encoder communications errors ^{*1}	Displays a value between 0 and FF hex. The cumulative count is saturated when it reaches the maximum value (FFFF hex). In this case, only the lowest order byte is shown.
6	Total number of external encoder communications errors ^{*1}	The value returns to 00 when it exceeds FF, but the count continues.
7	Z-phase counter ^{*2}	Displays the Z-phase count value read from the external encoder when an incremental external encoder is used during fully-closed control. The value between 0 and FF hex is displayed.
8 or over	Unused	Do not set anything.

*1 The cumulative count of communication errors is cleared when the control power is cut OFF.

*2 The value read from the encoder is indicated directly, regardless of the External Feedback Pulse Direction Switching (3326 hex).

3701 hex	Power ON Address Display Duration Setting						<input type="checkbox"/> All	
Setting range	0 to 1000	Unit	100 ms	Default setting	0	Data Attribute	R	
Size	2 bytes (INT16)		Access	RW	PDO map	Not possible.		

- Set the time to indicate the node address when the control power is turned ON.

3703 hex	Torque Limit Flag Output Setting						<input type="checkbox"/> cst	
Setting range	0 to 1	Unit	–	Default setting	0	Data Attribute	A	
Size	2 bytes (INT16)		Access	RW	PDO map	Not possible.		

- Set the condition for torque limit output during torque control.

Explanation of Set Value

Set value	Description
0	On by the torque limit value including the torque command value.
1	On by the torque limit value excluding the torque command value.

3704 hex	Backlash Compensation Selection						<input type="checkbox"/> csp <input type="checkbox"/> pp <input type="checkbox"/> hm	
Setting range	0 to 2	Unit	–	Default setting	0	Data Attribute	C	
Size	2 bytes (INT16)		Access	RW	PDO map	Not possible.		

- Select to enable or disable the backlash compensation during position control. Set the compensation direction when compensation is enabled.
- Refer to *7-4 Backlash Compensation* on page 7-13.

Explanation of Set Value

Set value	Description
0	Disable backlash compensation.
1	Compensate for backlash at first forward operation after the servo turns ON.
2	Compensate for backlash at first reverse operation after the servo turns ON.

3705 hex	Backlash Compensation Amount						<input type="checkbox"/> csp <input type="checkbox"/> pp <input type="checkbox"/> hm	
Setting range	–32768 to 32767	Unit	Command unit	Default setting	0	Data Attribute	B	
Size	2 bytes (INT16)		Access	RW	PDO map	Not possible.		

- Set the backlash compensation amount during position control.
- Refer to *7-4 Backlash Compensation* on page 7-13.

3706 hex	Backlash Compensation Time Constant						<input type="checkbox"/> csp <input type="checkbox"/> pp <input type="checkbox"/> hm	
Setting range	0 to 6400	Unit	0.01 ms	Default setting	0	Data Attribute	B	
Size	2 bytes (INT16)		Access	RW	PDO map	Not possible.		

- Set the backlash compensation time constant for position control.
- Refer to *7-4 Backlash Compensation* on page 7-13.

3758 hex	Touch Probe Trigger Selection						<input type="button" value="All"/>
Setting range	0000 to FFFF hex	Unit	–	Default setting	0100 hex	Data Attribute	B
Size	2 bytes (U16)		Access	RW	PDO map	Not possible.	

- Select EXT1, EXT2, EXT3, or phase Z at the external latch trigger for the latch function.
- For details on the latch function, refer to *7-11 Touch Probe Function (Latch Function)* on page 7-40.

Bit Descriptions

Latch 1			Latch 2		
Bit 0	Bit 1	Trigger signal 1	Bit 8	Bit 9	Trigger signal 2
0	0	EXT1	0	0	EXT1
1	0	EXT2	1	0	EXT2
0	1	EXT3	0	1	EXT3
1	1	Phase-Z signal	1	1	Phase-Z signal

3759 hex	Warning Hold Selection						<input type="button" value="All"/>
Setting range	0000 to FFFF hex	Unit	–	Default setting	0000 hex	Data Attribute	R
Size	2 bytes (U16)		Access	RW	PDO map	Not possible.	

- Select whether to hold communications-related and general warning status.

Bit Descriptions

Bit	Function	Set value	Warning status	Resetting warning status
0	Holding Communications-related Warning Status	0	Do not hold	The warnings are automatically cleared when the cause of the warning is eliminated. However, warnings are held for at least 1 s.
		1	Hold	Remove the cause of the warning and then send a warning reset command.
1	Holding General Warning Status ^{*1}	0	Do not hold	The warnings are automatically cleared when the cause of the warning is eliminated. However, warnings are held for at least 1 s.
		1	Hold	Remove the cause of the warning and then send a warning reset command.

*1 The warning state for the Battery Warning (A2 hex) and Life Expectancy Warning (A7 hex) will be held independent of this setting.

3781 hex	Data Setting Warning Detection Setting						All
Setting range	0 to 15	Unit	Times	Default setting	1	Data Attribute	C
Size	2 bytes (INT16)		Access	RW	PDO map	Not possible.	

- Set how many times the EtherCAT communications data setting warning should be detected continuously without an error.
- If a Data Setting Warning (Warning No. B0 hex) occurs more than this setting, a Command Error (Error No. 91.1) will occur.
- It can be set to between 0 and 15. The error will occur when the number of detected Data Setting Warning exceeds this set value + 1.



Additional Information

- This object is supported for unit version 2.1 or later.
- In the default setting, the data setting warning (Warning No. B0 hex) will not occur because the Communications Control (3800 hex) bit 14 is 1, and therefore no Command Error (Error No. 91.1) will occur.
- To enable this setting, set the Communications Control (3800 hex) bit 14 to 0.
- When you enable this setting and do not change the default setting value (default: 1), a Command Error will occur if the data setting warning is detected twice in a row.

3800 hex	Communications Control						All
Setting range	-32768 to 32767	Unit	–	Default setting	Refer to the description.	Data Attribute	C
Size	2 bytes (INT16)		Access	RW	PDO map	Not possible.	

- Set the error and warning masks for EtherCAT communications.



Precautions for Correct Use

This function is for debugging. For normal operation, leave this object at the default setting.

- Bit Descriptions

Bit	15	14	13	12	11	10	9	8	7	6	5	4	3	2	1	0
Function		Error masks								Warning masks			Error masks			

- Error masks
The following table shows the error you can mask by setting each error mask bit of the Communications Control object (3800 hex).
To mask an error, set the corresponding error bit to 1.

Communications Control (3800 hex)	Error	
	Error No. (hex)	Error name
Bit 1	83.1	EtherCAT state change error
Bit 2	83.2	EtherCAT illegal state change error
Bit 3	83.3	Communications synchronization error
Bit 12	83.4	Synchronization error
Bit 13	83.5	Sync Manager WDT Error
Bit 14 ^{*1}	91.1	Command Error

*1. Only Command Errors (Error No. 91.1) due to the data setting warning (B0 hex) are masked. Command Errors (Error No. 91.1) due to other causes are not masked.
For details on the causes of a Command Error (Error No. 91.1), refer to *Command error* on page 12-28.

- Warning masks

The following table shows the warning you can mask by setting each warning mask bit of the Communications Control object (3800 hex).

To mask a warning, set the corresponding warning bit to 1.

Communications Control (3800 hex)	Warning		
	Warning number	Warning name	Warning occurrence conditions
Bit 4	B0 hex	Data setting warning	<ul style="list-style-type: none"> The set value in the command argument is out of the specified range. Object write processing failed. The command set value is incorrect.
Bit 5	B1 hex	Command warning	<ul style="list-style-type: none"> The command transmission conditions are not met. The sub-command transmission conditions are not met. An operation command is given in the prohibited direction after the motor made an emergency stop due to a drive prohibition input.
Bit 6	B2 hex	EtherCAT communications warning	EtherCAT communications errors occurred one or more times.

- Default setting

The following table shows the default setting for each unit version.

Unit version	Default setting	Description
Ver. 2.0	0	The above masks are disabled. Bit 14 is reserved for system use. Do not change the default setting.
Ver. 2.1	16384	Because bit 14 is 1 in the default setting, only Command Errors (Error No. 91.1) due to the data setting warning (B0 hex) are masked.

3801 hex	Software Position Limit Function						All
Setting range	0 to 3	Unit	–	Default setting	3	Data Attribute	A
Size	2 bytes (INT16)		Access	RW	PDO map	Not possible.	

- Select whether to enable or disable the software position limit function.
- When it is enabled, set the software limit values in the Max position limit (607D-02 hex) and the Min position limit (607D-01 hex).

Explanation of Set Value

Set value	Description
0	Enable the software limits in both directions.
1	Disable the forward software limit, but enable the reverse software limit.
2	Enable the forward software limit, but disable the reverse software limit.
3	Disable the software limits in both directions.



Precautions for Correct Use

EtherCAT communications status will be 0 for limit signals that are disabled. The status will also be 0 if an origin return has not been performed.

3803 hex	Origin Range						<input type="checkbox"/> All
Setting range	0 to 250	Unit	Command unit	Default setting	10	Data Attribute	A
Size	2 bytes (INT16)		Access	RW	PDO map	Not possible.	

- Set the threshold for detecting the origin as an absolute value.

3818 hex	Position Command FIR Filter Time Constant						<input type="checkbox"/> csp <input type="checkbox"/> pp <input type="checkbox"/> hm
Setting range	0 to 10000	Unit	0.1 ms	Default setting	0	Data attribute	B
Size	2 bytes (INT16)		Access	RW	PDO map	Not possible.	

- Set the time constant of FIR filter for the position command.
- The Position command FIR filter can be selected to enable or disable, by the position command filter switch input via EtherCAT communications.
- Enable and disable the position command FIR filter in the Motion profile type (6086 hex). It can be set only when the Communications synchronization is 1 ms or more.
- It sets the time to arrive at the target speed V_c , as shown below, for the square-wave command of V_c .

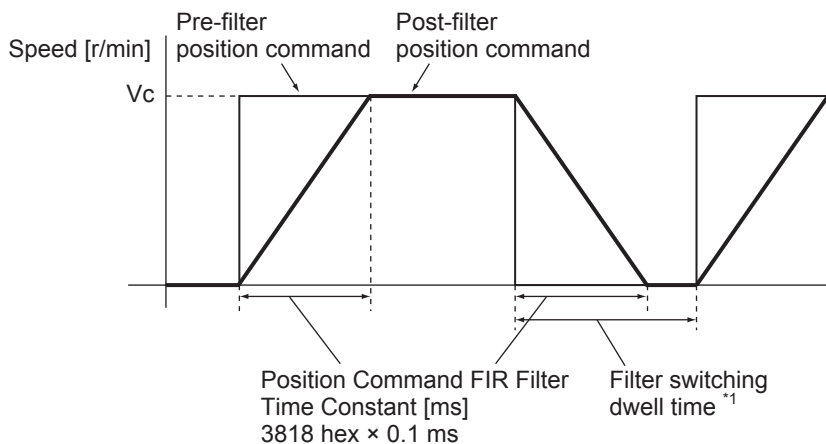

- *1 Change the setting on 3818 hex only after you stop the command pulse and the filter switching dwell time elapses. The dwell time is calculated by the following formulas depending on the value set on 3818 hex.
 If 3818 hex set value ≤ 10 ms, the set value $\times 0.1$ ms + 0.25 ms.
 If 3818 hex set value > 10 ms, the set value $\times 0.1$ ms $\times 1.05$.



Precautions for Correct Use

- If the set value on 3818 hex is changed during the position command is entered, the change is not reflected immediately. It is updated only after the subsequent state of no position command persists for the filter switching dwell time.
- There is some time lag from when the 3818 hex is change and to when the change is applied. If the filter switching dwell time elapses during the lag, the change may be suspended.

3822 hex	Reserved						
Setting range	–	Unit	–	Default setting	–	Data attribute	–
Size	–	Access	–	PDO map	–		

- This is a reserved parameter. Do not set any value.

10

Operation

This chapter explains the operating procedures and how to operate in each mode.

10-1 Operational Procedure	10-2
10-2 Preparing for Operation	10-3
10-2-1 Items to Check Before Turning ON the Power Supply	10-3
10-2-2 Turning ON the Power Supply	10-4
10-2-3 Checking the Displays	10-5
10-2-4 Absolute Encoder Setup	10-7
10-2-5 Setting Up an Absolute Encoder from the CX-Drive	10-7
10-3 Trial Operation	10-8
10-3-1 Preparations for Trial Operation	10-8
10-3-2 Test Operation via USB Communications from the CX-Drive	10-9

10-1 Operational Procedure

Turn ON the power supply after the correct installation and wiring to check the operation of the individual motor and drive.

Then make the function settings as required according to the use of the motor and drive.

If the user objects are set incorrectly, there is a risk of unexpected motor operation, which can be dangerous. Set the objects accurately according to the setting methods in this manual.

Item	Contents	Reference
Mounting and installation	Install the motor and drive according to the installation conditions. (Do not connect the motor to the mechanical system before checking no-load operation.)	Chapter 4, 4-1
↓		
Wiring and connections	Connect the motor and drive to the power supply and peripheral equipment. Specified installation and wiring conditions must be satisfied, particularly for models conforming to the EC Directives.	Chapter 4, 4-2
↓		
Preparing for operation	Check the necessary items and then turn ON the power supply. Check on the display to see whether there are any internal errors in the drive. If using a motor with an absolute encoder, first set up the absolute encoder.	Chapter 10, 10-2
↓		
Function settings	Set the objects related to the functions required for application conditions.	Chapter 9
↓		
Trial operation	First, check motor operation with no-load. Then turn the power supply OFF and connect the motor to the mechanical system. When using a Servomotor with an absolute encoder, set up the absolute encoder. Turn ON the power supply again, and check to see whether protective functions, such as the immediate stop and operational limits, are functioning properly. Check operation at both low speed and high speed using the system without a workpiece, or with dummy workpieces.	Chapter 10, 10-3
↓		
Adjustment	Manually adjust the gain if necessary. Further adjust the various functions to improve the control performance.	Chapter 11
↓		
Operation	Operation can now be started. If any problems should occur, refer to <i>Chapter 12 Troubleshooting and Maintenance</i> .	Chapter 12

10-2 Preparing for Operation

This section explains the procedure to prepare the mechanical system for operation following installation and wiring of the motor and drive. It explains items to check both before and after turning ON the power supply.

It also explains the setup procedure required if using a motor with an absolute encoder.

10-2-1 Items to Check Before Turning ON the Power Supply

Checking Power Supply Voltage

- Check to be sure that the power supply voltage is within the ranges shown below.

R88D-KNA5L-ECT/-KN01L-ECT/-KN02L-ECT/-KN04L-ECT (Single-phase 100-VAC input)

Main circuit power supply: Single-phase 100 to 120 VAC (85 to 132) 50/60 Hz

Control circuit power supply: Single-phase 100 to 120 VAC (85 to 132) 50/60 Hz

R88D-KN01H-ECT/-KN02H-ECT/-KN04H-ECT/-KN08H-ECT/-KN10H-ECT/-KN15H-ECT
(Single-phase or single-phase/3-phase 200-VAC input)

Main circuit power supply: Single-phase or single-phase/3-phase 200 to 240 VAC (170 to 264) 50/60 Hz

Control circuit power supply: Single-phase 200 to 240 VAC (170 to 264) 50/60 Hz

R88D-KN20H-ECT/-KN30H-ECT/-KN50H-ECT/-KN75H-ECT/-KN150H-ECT
(3-phase 200 VAC input)

Main circuit power supply: 3-phase 200 to 230 VAC (170 to 253) 50/60 Hz

Control circuit power supply: Single-phase 200 to 230 VAC (170 to 253) 50/60 Hz

R88D-KN06F-ECT/-KN10F-ECT/-KN15F-ECT/-KN20F-ECT/-KN30F-ECT/-KN50F-ECT/-KN75F-ECT/
-KN150F-ECT (3-phase 400 VAC input)

Main circuit power supply: 3-phase 380 to 480 VAC (323 to 528) 50/60 Hz

Control circuit power supply: 24 VDC \pm 15%

Checking Terminal Block Wiring

- The main circuit power supply inputs (L1/L3 or L1/L2/L3) must be properly connected to the terminal block.
- The control circuit power supply inputs (L1C/L2C) must be properly connected to the terminal block.
- The motor's red (U), white (V), and blue (W) power lines and the green/yellow (\oplus) must be properly connected to the terminal block.

Checking the Motor

- There should be no load on the motor. (Do not connect the mechanical system.)
- The motor side power lines and the power cables must be securely connected.

Checking the Encoder Wiring

- The encoder cable must be securely connected to the encoder connector (CN2) at the drive.
- The encoder cable must be securely connected to the encoder connector at the motor.

Checking the EtherCAT Communications Connectors

- The EtherCAT Communications Cables must be connected securely to the EtherCAT Communications Connectors (ECAT IN and ECAT OUT).

Checking the Node Address Setting

Make sure that the node address is correctly set on the node address switches.

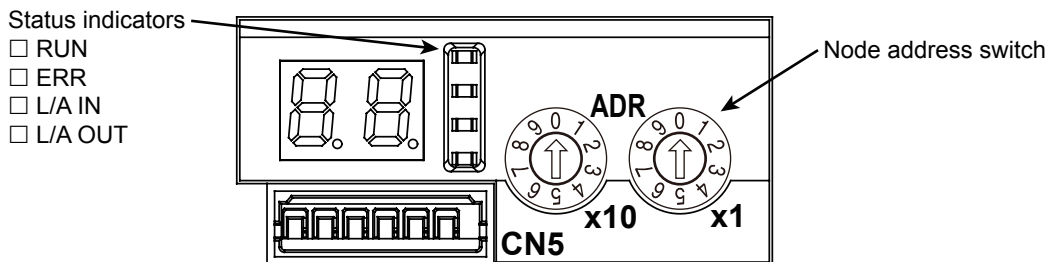

Node address switch setting	Contents
	Connection to NJ501-1□00 or CJ1W-NC281/NC481/NC881/NCF81/NC482/NC882 Position Control Unit
00	The controller sets the node address.
01 to 99	The Node Address switch setting is used as the node address.



Precautions for Correct Use

- Do not change the setting on the Node Address switches after the power supply has been turned ON.
- The node address switches can be set to between 00 and 99.
The node address used over the network is determined by the value set on the Node Address switches.
If the node address is not between 00 and 99, a Node Address Setting Error (Error No. 88.0) will occur.

10-2-2 Turning ON the Power Supply

- Turn ON the control circuit power after you conduct the pre-power-ON checking. You may turn ON the main circuit power, but it is not a required.

10-2-3 Checking the Displays

7-Segment Display

The 7-segment display is on the front panel.

When the power is turned ON, it shows the node address that is set by the rotary switches. Then the display changes according to the setting of the LED Display Selection (3700 hex).

An error code is displayed if an error occurs. A warning code is displayed if a warning occurs.

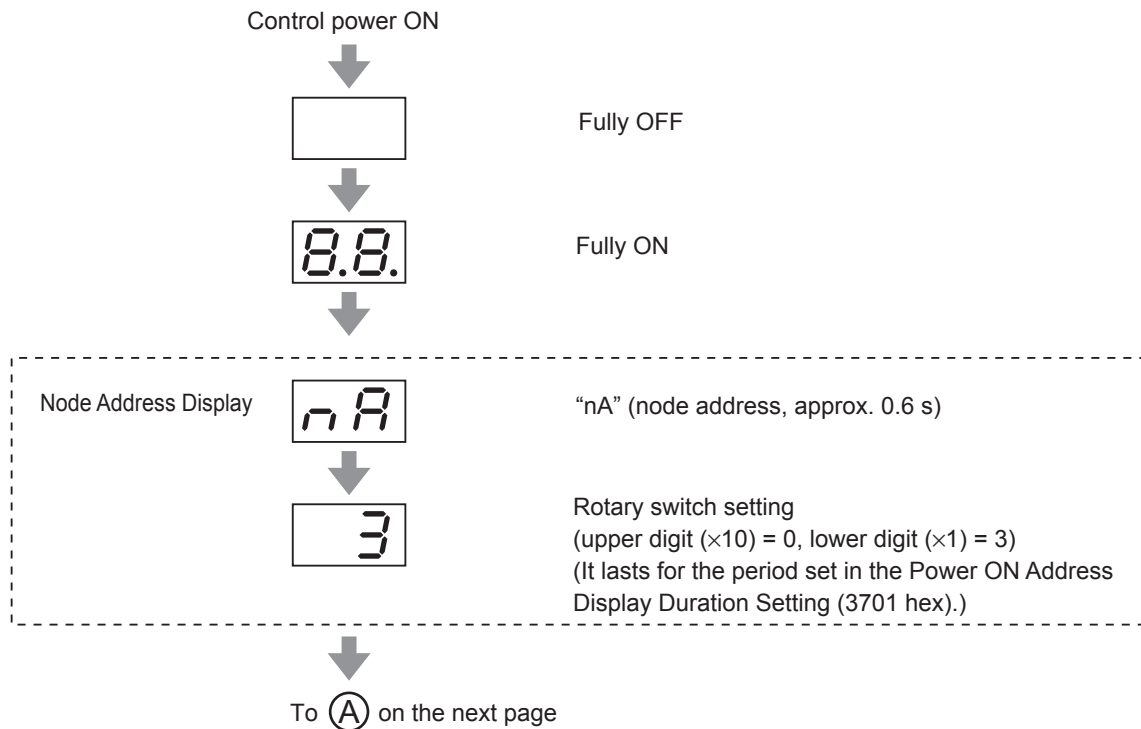

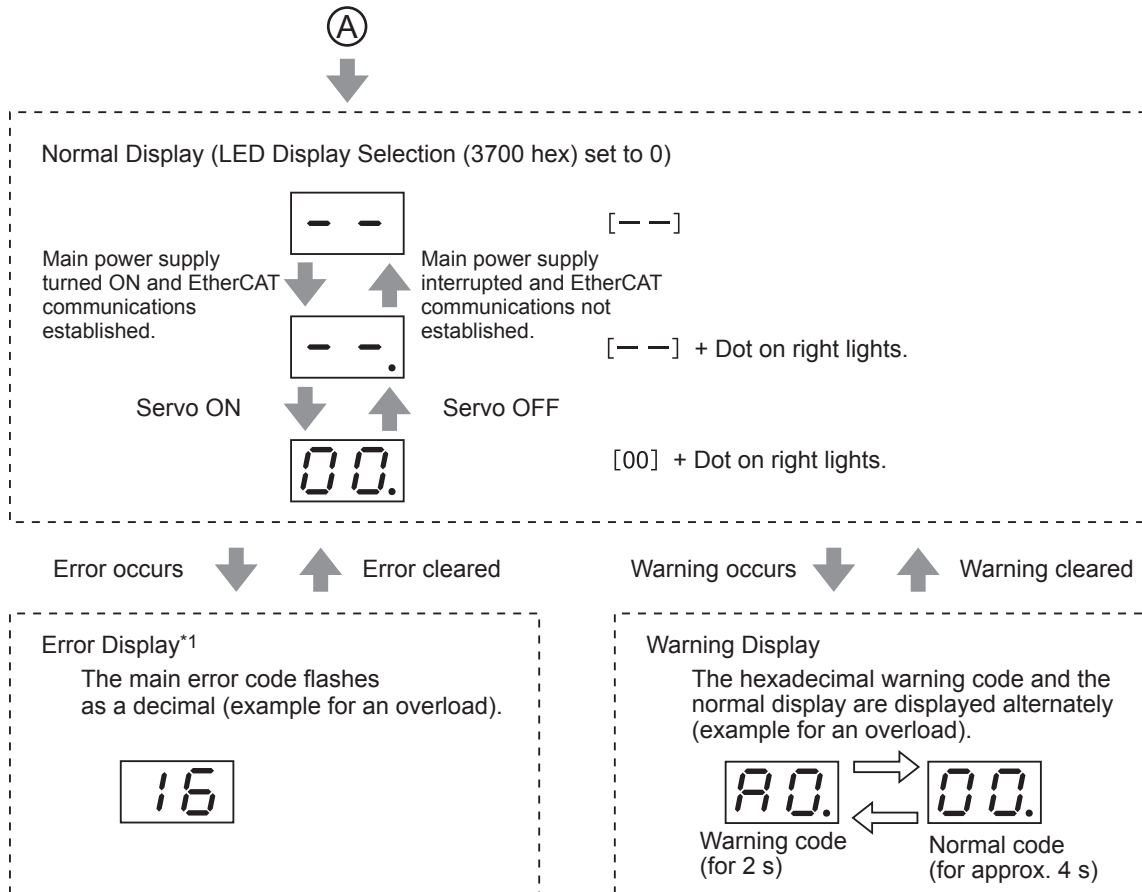

*1 : “SE” will flash when a Safety Input Error (Error No. 30.0) occurs.
 “30” does not flash on the display.

EtherCAT Status Indicators

Check the status of the status indicators.

If the RUN indicator will not turn ON or the ERR indicator will not turn OFF, refer to *Status Indicators* on page 5-3 and check the status.

10-2-4 Absolute Encoder Setup **ABS**

You must set up the absolute encoder if using a motor with an absolute encoder. The setup is required when you turn ON the power supply for the first time, when an Absolute Encoder System Down Error (Error No. 40.0) occurs, or when the encoder cable is disconnected and then connected again.

To use an absolute encoder, set the Operation Switch when Using Absolute Encoder (3015 hex) to 0 or 2 (factory setting).

Refer to the *CJ1W-NC281/NC481/NC881/NCF81/NC482/NC882 Position Control Unit Operation Manual* (Cat. No. W487) and to information on Absolute Encoder Setup (4102 hex) to set up the absolute encoder.

Set up an absolute encoder while the servo is OFF. Always cycle the power supply after completing the setup.

For information on setup using the CX-Drive, refer to “CX-Drive Operation Manual (W453-E1)” or Setting Up an Absolute Encoder from the CX-Drive described below.

10-2-5 Setting Up an Absolute Encoder from the CX-Drive

- 1** Start the CX-Drive and go online with the Servo Drive via EtherCAT or USB communications.
- 2** Select *Absolute Encoder* from the *Tuning* Menu of the CX-Drive.
- 3** Select *Multi-Turn Data and Encoder Error Clear* from the *Absolute Encoder* Dialog Box.

The following error will occur after execution has been completed.

EtherCAT communications:	Position Data Initialized (Error No. 27.7)
USB communications:	Absolute Value Cleared (Error No. 27.1)

- 4** Turn the power supply to the Servo Drive OFF and then ON again.

10-3 Trial Operation

When you have finished installation, wiring, and switch settings, and have confirmed that status is normal after turning ON the power supply, perform trial operation. The main purpose of trial operation is to confirm that the servo system is electrically correct.

If an error occurs during trial operation, refer to *Chapter 12 Troubleshooting and Maintenance* to eliminate the cause. Then check for safety, and retry trial operation.

10-3-1 Preparations for Trial Operation

Inspections before Trial Operation

Check the following items.

- **Wiring**

- Make sure that there are no wiring errors (especially for the power supply input and motor output).
- Make sure that there are no short-circuits. (Check the ground for short circuits as well.)
- Make sure that there are no loose connections.

- **Power Supply Voltage**

- Make sure that the voltage corresponds to the rated voltage.
- Is the voltage stable?

- **Motor Installation**

- Make sure that the Servomotor is securely installed.

- **Disconnection from Mechanical System**

- If necessary, make sure that the load has been disconnected from the mechanical system.

- **Brake Released**

- Make sure that the brake has been released.

- **Connections to the Mechanical System**

- Are the load and Servomotor shaft properly aligned?
- Is the load on the Servomotor shaft within specifications?

10-3-2 Test Operation via USB Communications from the CX-Drive

- 1** Use the Connector CN1.
- 2** Turn ON the Servo Drive power.
- 3** Connect a USB cable to the USB connector (CN7).
- 4** Start the CX-Drive and go online with the Servo Drive via USB communications.
- 5** Select *Test Run* from the *Tuning* Menu of the CX-Drive.
- 6** Select *Servo ON* to servo-lock the Servomotor.
- 7** Select *Forward* or *Reverse* and start the Servomotor.
The Servomotor will rotate until *Stop* is selected.



Precautions for Correct Use

The test operation function via USB communications from the CX-Drive cannot be used while EtherCAT communications are established.

Adjustment Functions

This chapter explains the functions, setting methods, and items to note regarding various gain adjustments.

11-1 Analog Monitor	11-2
11-1-1 Objects Requiring Settings	11-2
11-2 Gain Adjustment	11-5
11-2-1 Purpose of the Gain Adjustment	11-5
11-2-2 Gain Adjustment Methods	11-5
11-2-3 Gain Adjustment Procedure	11-6
11-3 Realtime Autotuning	11-7
11-3-1 Objects Requiring Settings	11-8
11-3-2 Setting Realtime Autotuning	11-8
11-3-3 Setting Machine Rigidity	11-9
11-4 Manual Tuning	11-15
11-4-1 Basic Settings	11-15
11-5 Damping Control	11-17
11-5-1 Objects Requiring Settings	11-17
11-5-2 Operating Procedure	11-18
11-6 Adaptive Filter	11-20
11-6-1 Objects Requiring Settings	11-21
11-6-2 Operating Procedure	11-22
11-7 Notch Filters	11-23
11-7-1 Objects Requiring Settings	11-24
11-7-2 Notch Filter Width and Depth	11-24
11-8 Disturbance Observer Function	11-26
11-8-1 Operating Conditions	11-26
11-8-2 Objects Requiring Settings	11-27
11-8-3 Operating Procedure	11-27
11-9 Friction Torque Compensation Function	11-28
11-9-1 Operating Conditions	11-28
11-9-2 Objects Requiring Settings	11-28
11-9-3 Operation Example	11-29
11-10 Hybrid Vibration Suppression Function	11-30
11-10-1 Operating Conditions	11-30
11-10-2 Objects Requiring Settings	11-30
11-10-3 Operating Procedure	11-30
11-11 Feed-forward Function	11-31
11-11-1 Objects Requiring Settings	11-31
11-11-2 Operating Procedure	11-32
11-12 Instantaneous Speed Observer Function	11-34
11-12-1 Operating Conditions	11-34
11-12-2 Objects Requiring Settings	11-34
11-12-3 Operating Procedure	11-35

11-1 Analog Monitor

Two types of analog signals can be output from the analog monitor connector on the front panel.

They are used when the monitoring is required for adjustment.

The monitor items to be output and the scaling (output gain) can be set as required for each of the objects.

The refresh period of the analog monitor is 1 ms. The analog monitor is not synchronized with another axes in the EtherCAT system.

11-1-1 Objects Requiring Settings

Index	Name	Explanation	Reference
3416 hex	Analog Monitor 1 Selection	Select the monitoring item for the analog monitor 1.	page 9-33
3417 hex	Analog Monitor 1 Scale Setting	Set the output gain for the analog monitor 1.	page 9-33
3418 hex	Analog Monitor 2 Selection	Select the monitoring item for the analog monitor 2.	page 9-34
3419 hex	Analog Monitor 2 Scale Setting	Set the output gain for the analog monitor 2.	page 9-34
3421 hex	Analog Monitor Output Setting	Select the analog monitor output method.	page 9-34

Analog Monitor Objects (3416, 3417, 3418 and 3419 Hex)

The analog monitor scales (3417 hex and 3419 hex) are set in units for 1 V. When the objects are set to 0, the values shown in the table below are automatically set.

3416 hex and 3418 hex set value	Description		
	Monitoring item	Unit	Output gain when 3417 hex and 3419 hex are set to 0
0	Feedback Motor Speed	r/min	500
1	Internal Command Motor Speed ^{*1}	r/min	500
2	Filtered Internal Command Motor Speed ^{*1}	r/min	500
3	Motor Control Effort	r/min	500
4	Torque demand	%	33
5	Position Error ^{*2}	pulses (command units)	3,000
6	Pulse Position Error ^{*2}	pulses (encoder units)	3,000
7	Fully-closed Error ^{*2}	pulses (external encoder unit)	3,000
8	Hybrid Error	pulses (command units)	3,000
9	P-N Voltage	V	80
10	Regeneration Load Ratio	%	33
11	Motor Load Ratio	%	33
12	Forward Torque Limit	%	33
13	Reverse Torque Limit	%	33
14	Speed Limit Value	r/min	500
15	Inertia Ratio	%	500

3416 hex and 3418 hex set value	Description		
	Monitoring item	Unit	Output gain when 3417 hex and 3419 hex are set to 0
16 to 18	Reserved	—	—
19	Encoder Temperature ^{*3}	°C	10
20	Servo Drive Temperature	°C	10
21	Encoder 1-rotation Data ^{*4}	pulses (encoder units)	110,000

*1 The Internal Command Motor Speed is the speed before the command input passes through the command filter (the position command filter time constant and the smoothing filter time constant). The Filtered Internal Command Motor Speed is the speed after the command input passes through the command filter.

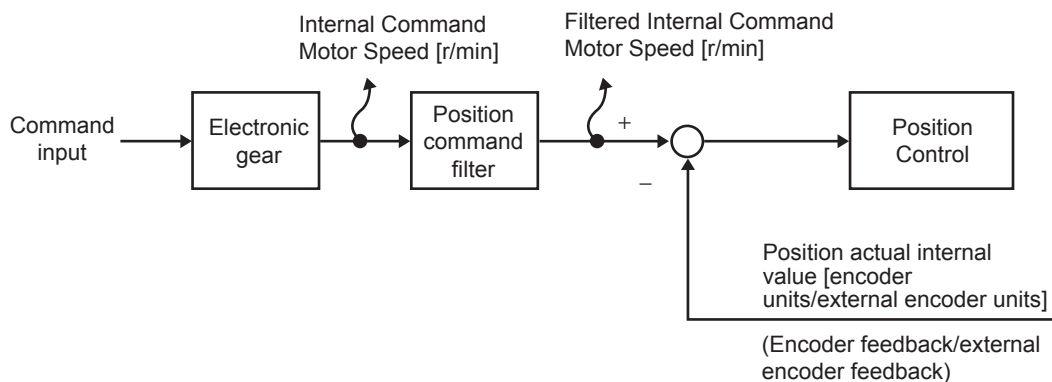

*2 The position error is calculated for the command input after processing for the position command filter. The pulse position error or fully-closed position error is reversely converted to command units for application. The pulse position error or fully-closed error is the error for the position control input.

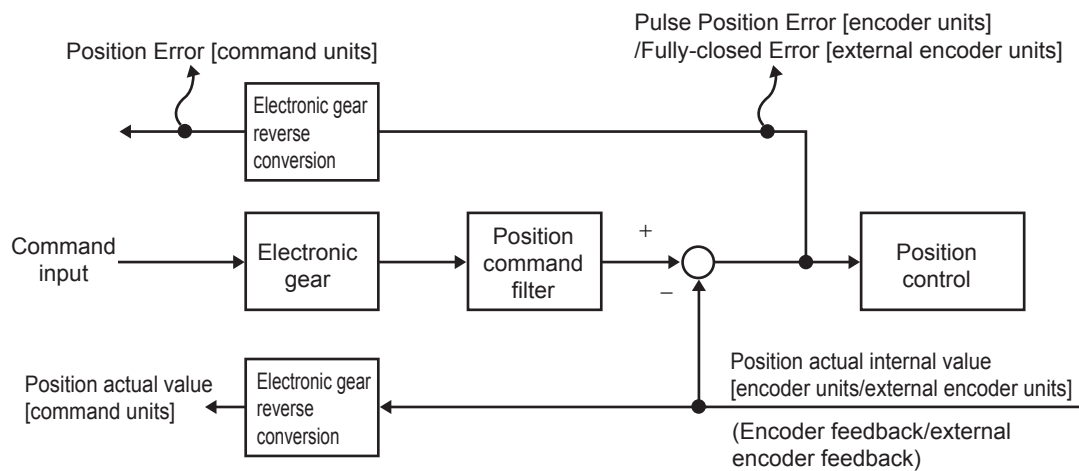

*3 The encoder temperature is indicated only for a 20-bit incremental encoder. The value is not stable for other types of encoders.

*4 The direction of monitor data, either forward or reverse, is the direction set in the Rotation Direction Switching (3000 hex). However, CCW is the forward direction for the absolute encoder 1-rotation data. A normal value is output from the incremental encoder after the first phase Z.

Analog Monitor Output Setting (3421 Hex)

Select the direction for analog monitor output voltage.

These are the output voltage range and the output direction when the Analog Monitor 1 Selection or Analog Monitor 2 Selection is set to the feedback motor speed, and the Analog Monitor 1 Scale Setting or the Analog Monitor 2 Scale Setting is set to 0 (i.e., 1V = 500 r/min).

Set value	Output range	Data output
0	-10 to 10 V	
1	0 to 10 V	
2	0 to 10 V (5 V as the center)	

11-2 Gain Adjustment

G5-Series Servo Drives provide a realtime autotuning function.

With this function, gain adjustments can be made easily even by those using a servo system for the first time.

If you cannot obtain the desired responsiveness with autotuning, use manual tuning.

11-2-1 Purpose of the Gain Adjustment

The Servo Drive must operate the motor in response to commands from the host system with minimal time delay and maximum reliability. The gain is adjusted to bring the actual operation of the motor as close as possible to the operation specified by the commands, and to maximize the performance of the machine.

Example: Ball screw

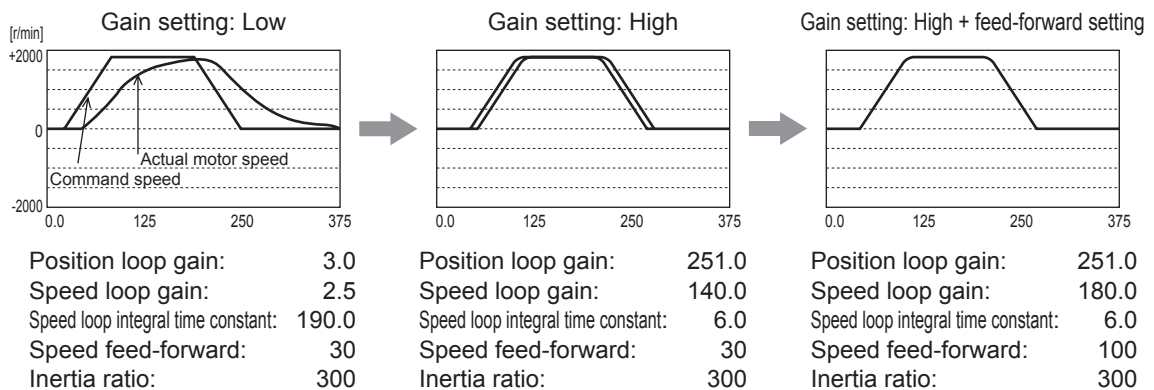

11-2-2 Gain Adjustment Methods

Function		Description	Reference page
Automatic adjustment	Realtime autotuning	Realtime autotuning estimates the load inertia of the machine in realtime and automatically sets the optimal gain according to the estimated load inertia.	page 11-7
Manual adjustment	Manual tuning	Manual adjustment is performed if autotuning cannot be executed due to restrictions on the control mode or load conditions or if ensuring that the maximum responsiveness matches each load is required.	page 11-15
	Basic procedure	Position Control/Fully-closed Control Mode adjustment	page 11-16



Precautions for Safe Use

- Take sufficient measures to ensure safety.
- If vibration occurs (unusual noise or vibration), immediately turn OFF the power supply or turn OFF the servo.

11-2-3 Gain Adjustment Procedure

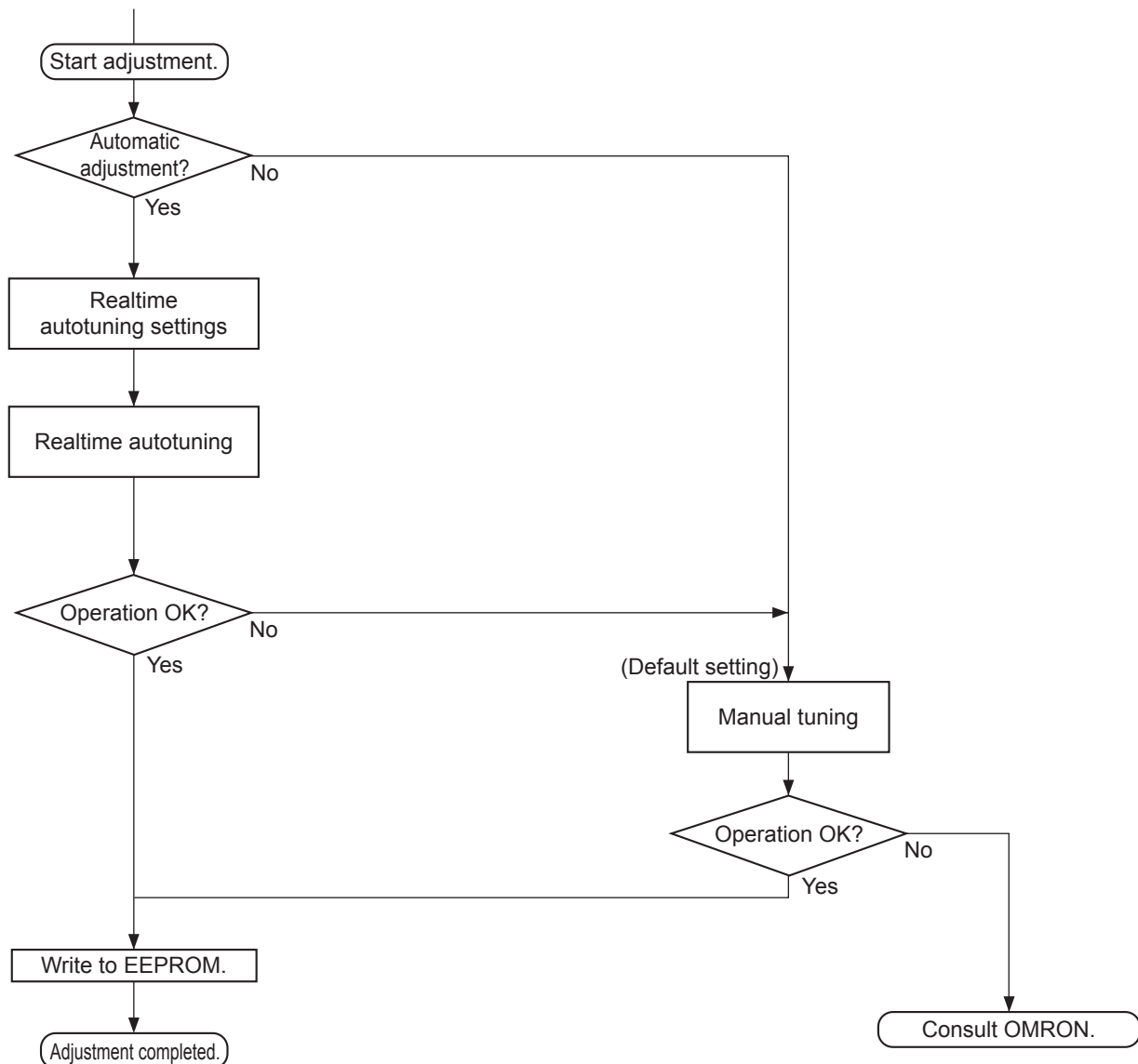

Gain Adjustment and Machine Rigidity

To improve machine rigidity:

- Install the machine on a secure base so that it does not have any play.
- Use couplings that have a high rigidity, and that are designed for servo systems.
- Use a wide timing belt, and use a tension within the range of allowable axial load for the motor.
- Use gears with small backlash.

The specific vibration (resonance frequencies) of the mechanical system has a large impact on the gain adjustment of the servo. The servo system responsiveness cannot be set high for machines with a low resonance frequency (low machine rigidity).

11-3 Realtime Autotuning

Realtime autotuning estimates the load inertia of the machine in realtime, and operates the machine by automatically setting the gain according to the estimated load inertia. At the same time, it can lower the resonance and vibration if the adaptive filter is enabled.

Refer to *11-6 Adaptive Filter* on page 11-20 for details about adaptive filters.

Realtime autotuning is enabled for any control to adjust the speed loop PI control.

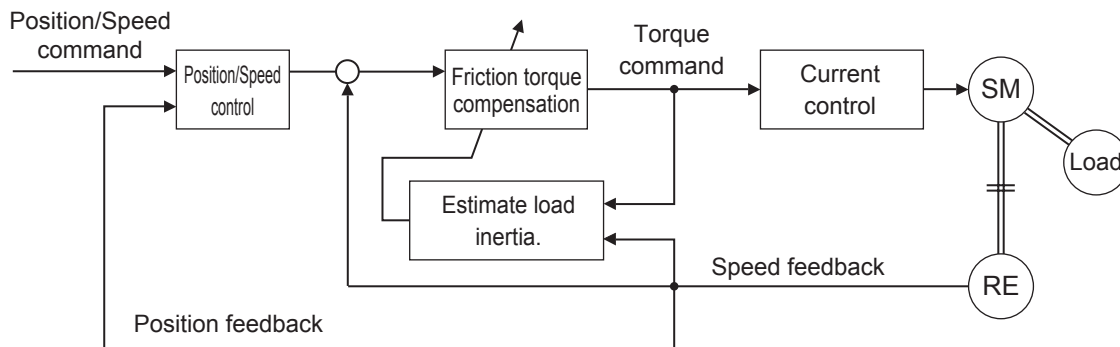

Precautions for Correct Use

- Realtime autotuning may not function properly under the conditions described in the following table. In such cases, use manual tuning.

	Conditions under which realtime autotuning does not operate properly
Load inertia	<ul style="list-style-type: none"> If the load inertia is too small or too large compared with the rotor inertia (less than 3 times, more than 20 times, or more than the applicable load inertia ratio). If the load inertia changes quickly.
Load	<ul style="list-style-type: none"> If the machine rigidity is extremely low. If there is a non-linear element (play), such as a backlash.
Operation pattern	<ul style="list-style-type: none"> If the speed continues at below 100 r/min. If the acceleration/deceleration is below 2,000 r/min in 1 s. If the acceleration/deceleration torque is too small compared with the unbalanced load and the viscous friction torque. If either a speed of 100 r/min or higher, or an acceleration/deceleration of 2,000 r/min/s does not last for at least 50 ms.

- With realtime autotuning, each object is fixed to the value in the machine rigidity table at the time the machine rigidity is set. By estimating the load inertia from the operation pattern, the operation coefficient for the speed loop gain and the integral time constant are altered. Doing this for each pattern can cause vibration, so the estimation value is set conservatively.
- The torque feed-forward function cannot be used when realtime autotuning is being used. Set both the Torque Feed-forward Gain (3112 hex) and Torque Feed-forward Command Filter (3113 hex) to 0.

11-3-1 Objects Requiring Settings

Index	Name	Explanation	Reference
3002 hex	Realtime Autotuning Mode Selection	Set the operation mode for the realtime autotuning.	page 9-3
3003 hex	Realtime Autotuning Machine Rigidity Setting	Set the responsiveness when the realtime autotuning is enabled.	page 9-4
3631 hex	Realtime Autotuning Estimated Speed Selection	Set the speed to estimate the load characteristic when the realtime autotuning is enabled.	page 9-50
3632 hex	Realtime Autotuning Customization Mode Setting	Make detailed settings for the autotuning function, when the customized mode (3002 hex = 6) is selected in the Realtime Autotuning Mode Selection (3002 hex).	page 9-51

11-3-2 Setting Realtime Autotuning

- 1** When setting realtime autotuning, turn the servo OFF.
- 2** Set Realtime Autotuning mode Selection (3002 hex) depending on the load.

Normally, set the object to 1 or 2.

Use a setting of 3 or 4 when a vertical axis is used.

A setting of 5 is used in combination with a software tool. Do not use it for normal operation.

Gain switching function is enabled for set values 2 to 4.

Set value	Realtime autotuning	Description
0	Disabled	Realtime autotuning is disabled.
1	Focus on stability (default setting)	No unbalanced load or friction compensation, nor gain switching.
2	Focus on positioning	Used for a horizontal axis or others that have no unbalanced load, or for a ball screw drive with little friction.
3	Vertical axis	Used when unbalanced load is present, i.e., with a vertical axis, etc.
4	Friction compensation and vertical axis	Used when a vertical axis or other unbalanced load is present and when friction is large. Used for a belt-driving shaft with large friction. Variations in finalizing the positioning are suppressed.
5	Load characteristic estimation	Used only for estimating load characteristics.
6	Customization	Detailed customization can be set in the Realtime Autotuning Customization Mode Setting (3632 hex).

11-3-3 Setting Machine Rigidity

- 1 Set the Realtime Autotuning Machine Rigidity Setting (3003 hex) according to the table below. Start from the lower machine rigidity number and check the operation.

Machine configuration and drive method	Realtime Autotuning Machine Rigidity Setting (3003 hex)
Ball screw direct coupling	12 to 24
Ball screw and timing belt	8 to 20
Timing belt	4 to 16
Gears, rack and pinion drive	4 to 16
Other machines with low rigidity	1 to 8
Stacker cranes	Perform manual tuning.

- 2 Turn the servo ON and operate the machine with a normal pattern.
To increase responsiveness, increase the machine rigidity number, and check the response. If vibration occurs, enable the adaptive filter and operate. If already enabled, lower the machine rigidity number.
- 3 If there are no problems with the operation, turn the servo OFF and set the Realtime Autotuning Mode Selection (3002 hex) to 0 (disabled).

The adaptive filter can be left enabled even if realtime autotuning is disabled after the completion of adjustments. Even if the adaptive filter is disabled, the settings of notch filters 3 and 4 are held.



Precautions for Correct Use

- After startup, immediately after the first servo ON, or when the Realtime Autotuning Machine Rigidity Setting (3003 hex) is increased, unusual noise or vibration may occur until the load inertia is estimated or the adaptive filter stabilizes. This is not an error if it disappears right away. If the unusual noise or vibration, however, continues for 3 or more reciprocating operations, take the following measures in any order you can.
 - Write the objects used during normal operation to the EEPROM.
 - Lower the Realtime Autotuning Machine Rigidity Setting (3003 hex).
 - Manually set the notch filter.
- Once unusual noise or vibration occurs, Inertia Ratio (3004 hex), Torque Command Value Offset (3607 hex), Forward Direction Torque Offset (3608 hex), and Reverse Direction Torque Offset (3609 hex) may have changed to an extreme value. In this case, also take the measures described above.
- Out of the results of realtime autotuning, the Inertia Ratio (3004 hex), Torque Command Value Offset (3607 hex), Forward Direction Torque Offset (3608 hex) and Reverse Direction Torque Offset (3609 hex) are automatically saved to the EEPROM every 30 minutes. Realtime autotuning uses this saved data as the default settings when the power supply is turned ON again.
- The object is automatically set based on the Realtime Autotuning Machine Rigidity Setting (3003 hex) if realtime autotuning is enabled.

● Realtime Autotuning (RTAT) Object Table

Index	Name	AT Machine Rigidity Setting (3003 hex)							
		0	1	2	3	4	5	6	7
3004 hex	Inertia Ratio	Estimated load inertia ratio							
3100 hex	Position Loop Gain 1	20	25	30	40	45	55	75	95
3101 hex	Speed Loop Gain 1	15	20	25	30	35	45	60	75
3102 hex	Speed Loop Integral Time Constant 1	3700	2800	2200	1900	1600	1200	900	700
3103 hex	Speed Feedback Filter Time Constant 1	0	0	0	0	0	0	0	0
3104 hex	Torque Command Filter Time Constant 1* ¹	1500	1100	900	800	600	500	400	300
3105 hex	Position Loop Gain 2	25	30	40	45	55	70	95	120
3106 hex	Speed Loop Gain 2	15	20	25	30	35	45	60	75
3107 hex	Speed Loop Integral Time Constant 2* ²	10000	10000	10000	10000	10000	10000	10000	10000
3108 hex	Speed Feedback Filter Time Constant 2	0	0	0	0	0	0	0	0
3109 hex	Torque Command Filter Time Constant 2* ¹	1500	1100	900	800	600	500	400	300
3110 hex	Speed Feed-forward Gain	300	300	300	300	300	300	300	300
3111 hex	Speed Feed-forward Command Filter	50	50	50	50	50	50	50	50
3112 hex	Torque Feed-forward Gain	0	0	0	0	0	0	0	0
3113 hex	Torque Feed-forward Command Filter	0	0	0	0	0	0	0	0
3114 hex	Gain Switching Input Operating Mode Selection	1	1	1	1	1	1	1	1
3115 hex	Switching Mode in Position Control	Gain Switching Enable Mode: 10 Gain Switching Disable Mode: 0							
3116 hex	Gain Switching Delay Time in Position Control	30	30	30	30	30	30	30	30
3117 hex	Gain Switching Level in Position Control	50	50	50	50	50	50	50	50
3118 hex	Gain Switching Hysteresis in Position Control	33	33	33	33	33	33	33	33
3119 hex	Position Gain Switching Time	33	33	33	33	33	33	33	33
3607 hex	Torque Command Value Offset	Estimated torque command additional value							
3608 hex	Forward Direction Torque Offset	Estimated positive torque compensation value							
3609 hex	Reverse Direction Torque Offset	Estimated negative torque compensation value							
3610 hex.0, 3610 hex.1	Function Expansion Setting	0	0	0	0	0	0	0	0
3623 hex	Disturbance Torque Compensation Gain	0	0	0	0	0	0	0	0
3624 hex	Disturbance Observer Filter Setting	0	0	0	0	0	0	0	0

*1 This is limited to a minimum value of 10 if a 17-bit absolute encoder is used.

*2 If realtime autotuning is performed in vertical axis mode or friction compensation and vertical axis mode, the value will be 9999 until load characteristic estimation (estimation of the inertia ratio, torque command value offset, and forward/reverse direction torque offset) is completed. The value will change to 10000 after the load characteristic estimation is completed.

Index	Name	AT Machine Rigidity Setting (3003 hex)							
		8	9	10	11	12	13	14	15
3004 hex	Inertia Ratio	Estimated load inertia ratio							
3100 hex	Position Loop Gain 1	115	140	175	320	390	480	630	720
3101 hex	Speed Loop Gain 1	90	110	140	180	220	270	350	400
3102 hex	Speed Loop Integral Time Constant 1	600	500	400	310	250	210	160	140
3103 hex	Speed Feedback Filter Time Constant 1	0	0	0	0	0	0	0	0
3104 hex	Torque Command Filter Time Constant 1* ¹	300	200	200	126	103	84	65	57
3105 hex	Position Loop Gain 2	140	175	220	380	460	570	730	840
3106 hex	Speed Loop Gain 2	90	110	140	180	220	270	350	400
3107 hex	Speed Loop Integral Time Constant 2* ²	10000	10000	10000	10000	10000	10000	10000	10000
3108 hex	Speed Feedback Filter Time Constant 2	0	0	0	0	0	0	0	0
3109 hex	Torque Command Filter Time Constant 2* ¹	300	200	200	126	103	84	65	57
3110 hex	Speed Feed-forward Gain	300	300	300	300	300	300	300	300
3111 hex	Speed Feed-forward Command Filter	50	50	50	50	50	50	50	50
3112 hex	Torque Feed-forward Gain	0	0	0	0	0	0	0	0
3113 hex	Torque Feed-forward Command Filter	0	0	0	0	0	0	0	0
3114 hex	Gain Switching Input Operating Mode Selection	1	1	1	1	1	1	1	1
3115 hex	Switching Mode in Position Control	Gain Switching Enable Mode: 10 Gain Switching Disable Mode: 0							
3116 hex	Gain Switching Delay Time in Position Control	30	30	30	30	30	30	30	30
3117 hex	Gain Switching Level in Position Control	50	50	50	50	50	50	50	50
3118 hex	Gain Switching Hysteresis in Position Control	33	33	33	33	33	33	33	33
3119 hex	Position Gain Switching Time	33	33	33	33	33	33	33	33
3607 hex	Torque Command Value Offset	Estimated torque command additional value							
3608 hex	Forward Direction Torque Offset	Estimated positive torque compensation value							
3609 hex	Reverse Direction Torque Offset	Estimated negative torque compensation value							
3610 hex.0, 3610 hex.1	Function Expansion Setting	0	0	0	0	0	0	0	0
3623 hex	Disturbance Torque Compensation Gain	0	0	0	0	0	0	0	0
3624 hex	Disturbance Observer Filter Setting	0	0	0	0	0	0	0	0

*1 This is limited to a minimum value of 10 if a 17-bit absolute encoder is used.

*2 If realtime autotuning is performed in vertical axis mode or friction compensation and vertical axis mode, the value will be 9999 until load characteristic estimation (estimation of the inertia ratio, torque command value offset, and forward/reverse direction torque offset) is completed. The value will change to 10000 after the load characteristic estimation is completed.

Index	Name	AT Machine Rigidity Setting (3003 hex)							
		16	17	18	19	20	21	22	23
3004 hex	Inertia Ratio	Estimated load inertia ratio							
3100 hex	Position Loop Gain 1	900	1080	1350	1620	2060	2510	3050	3770
3101 hex	Speed Loop Gain 1	500	600	750	900	1150	1400	1700	2100
3102 hex	Speed Loop Integral Time Constant 1	120	110	90	80	70	60	50	40
3103 hex	Speed Feedback Filter Time Constant 1	0	0	0	0	0	0	0	0
3104 hex	Torque Command Filter Time Constant 1*1	45	38	30	25	20	16	13	11
3105 hex	Position Loop Gain 2	1050	1260	1570	1880	2410	2930	3560	4400
3106 hex	Speed Loop Gain 2	500	600	750	900	1150	1400	1700	2100
3107 hex	Speed Loop Integral Time Constant 2*2	10000	10000	10000	10000	10000	10000	10000	10000
3108 hex	Speed Feedback Filter Time Constant 2	0	0	0	0	0	0	0	0
3109 hex	Torque Command Filter Time Constant 2*1	45	38	30	25	20	16	13	11
3110 hex	Speed Feed-forward Gain	300	300	300	300	300	300	300	300
3111 hex	Speed Feed-forward Command Filter	50	50	50	50	50	50	50	50
3112 hex	Torque Feed-forward Gain	0	0	0	0	0	0	0	0
3113 hex	Torque Feed-forward Command Filter	0	0	0	0	0	0	0	0
3114 hex	Gain Switching Input Operating Mode Selection	1	1	1	1	1	1	1	1
3115 hex	Switching mode in Position Control	Gain Switching Enable Mode: 10 Gain Switching Disable Mode: 0							
3116 hex	Gain Switching Delay Time in Position Control	30	30	30	30	30	30	30	30
3117 hex	Gain Switching Level in Position Control	50	50	50	50	50	50	50	50
3118 hex	Gain Switching Hysteresis in Position Control	33	33	33	33	33	33	33	33
3119 hex	Position Gain Switching Time	33	33	33	33	33	33	33	33
3607 hex	Torque Command Value Offset	Estimated torque command additional value							
3608 hex	Forward Direction Torque Offset	Estimated positive torque compensation value							
3609 hex	Reverse Direction Torque Offset	Estimated negative torque compensation value							
3610 hex.0, 3610 hex.1	Function Expansion Setting	0	0	0	0	0	0	0	0
3623 hex	Disturbance Torque Compensation Gain	0	0	0	0	0	0	0	0
3624 hex	Disturbance Observer Filter Setting	0	0	0	0	0	0	0	0

*1 This is limited to a minimum value of 10 if a 17-bit absolute encoder is used.

*2 If realtime autotuning is performed in vertical axis mode or friction compensation and vertical axis mode, the value will be 9999 until load characteristic estimation (estimation of the inertia ratio, torque command value offset, and forward/reverse direction torque offset) is completed. The value will change to 10000 after the load characteristic estimation is completed.

Index	Name	AT Machine Rigidity Setting (3003 hex)							
		24	25	26	27	28	29	30	31
3004 hex	Inertia Ratio	Estimated load inertia ratio							
3100 hex	Position Loop Gain 1	4490	5000	5600	6100	6600	7200	8100	9000
3101 hex	Speed Loop Gain 1	2500	2800	3100	3400	3700	4000	4500	5000
3102 hex	Speed Loop Integral Time Constant 1	40	35	30	30	25	25	20	20
3103 hex	Speed Feedback Filter Time Constant 1	0	0	0	0	0	0	0	0
3104 hex	Torque Command Filter Time Constant 1* ¹	9	8	7	7	6	6	5	5
3105 hex	Position Loop Gain 2	5240	5900	6500	7100	7700	8400	9400	10500
3106 hex	Speed Loop Gain 2	2500	2800	3100	3400	3700	4000	4500	5000
3107 hex	Speed Loop Integral Time Constant 2* ²	10000	10000	10000	10000	10000	10000	10000	10000
3108 hex	Speed Feedback Filter Time Constant 2	0	0	0	0	0	0	0	0
3109 hex	Torque Command Filter Time Constant 2* ¹	9	8	7	7	6	6	5	5
3110 hex	Speed Feed-forward Gain	300	300	300	300	300	300	300	300
3111 hex	Speed Feed-forward Command Filter	50	50	50	50	50	50	50	50
3112 hex	Torque Feed-forward Gain	0	0	0	0	0	0	0	0
3113 hex	Torque Feed-forward Command Filter	0	0	0	0	0	0	0	0
3114 hex	Gain Switching Input Operating Mode Selection	1	1	1	1	1	1	1	1
3115 hex	Switching mode in Position Control	Gain Switching Enable Mode: 10 Gain Switching Disable Mode: 0							
3116 hex	Gain Switching Delay Time in Position Control	30	30	30	30	30	30	30	30
3117 hex	Gain Switching Level in Position Control	50	50	50	50	50	50	50	50
3118 hex	Gain Switching Hysteresis in Position Control	33	33	33	33	33	33	33	33
3119 hex	Position Gain Switching Time	33	33	33	33	33	33	33	33
3607 hex	Torque Command Value Offset	Estimated torque command additional value							
3608 hex	Forward Direction Torque Offset	Estimated positive torque compensation value							
3609 hex	Reverse Direction Torque Offset	Estimated negative torque compensation value							
3610 hex.0, 3610 hex.1	Function Expansion Setting	0	0	0	0	0	0	0	0
3623 hex	Disturbance Torque Compensation Gain	0	0	0	0	0	0	0	0
3624 hex	Disturbance Observer Filter Setting	0	0	0	0	0	0	0	0

*1 This is limited to a minimum value of 10 if a 17-bit absolute encoder is used.

- *2 If realtime autotuning is performed in vertical axis mode or friction compensation and vertical axis mode, the value will be 9999 until load characteristic estimation (estimation of the inertia ratio, torque command value offset, and forward/reverse direction torque offset) is completed. The value will change to 10000 after estimation of the load characteristics is completed.

11-4 Manual Tuning

As described before, the G5-series have a realtime autotuning function. Readjustment, however, is required if realtime autotuning cannot adjust the gain properly for some reasons: there is a restriction by load conditions, or a necessity to ensure optimum responsiveness and stability for each load.

This section describes how to perform manual tuning.

11-4-1 Basic Settings

Before Manual Setting

More reliable adjustment can be performed quickly by using waveform monitoring with the data tracing function of the CX-Drive or by measuring the analog voltage waveform with the monitor function.

● Analog Monitor Output

The feedback motor speed, internal command motor speed, command torque, and position error can be measured as an analog voltage level using an oscilloscope or other device. The type of signal to output and the output voltage level are set with Analog Monitor 1 Selection (3416 hex) and Analog Monitor 2 Selection (3418 hex) settings. For details, refer to *11-1 Analog Monitor* on page 11-2.

● CX-Drive Data Tracing Function

Commands to the motor and motor operation (speed, command torque, and position error) can be displayed on a computer as waveforms. Refer to the *CX-Drive Operation Manual* (Cat. No. W453).

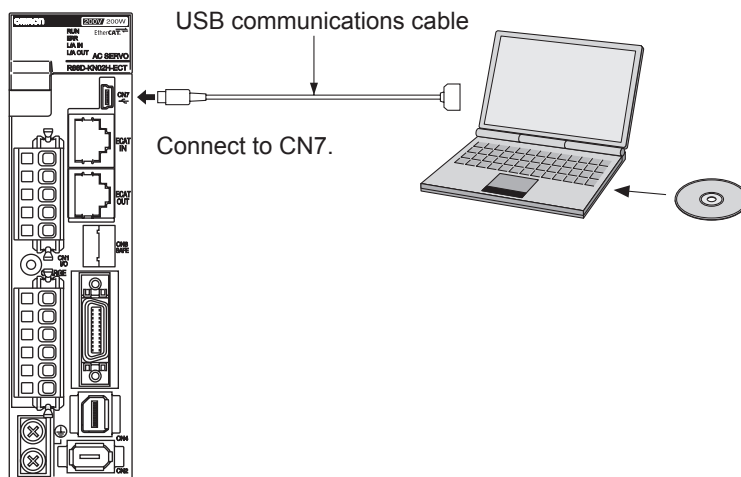

Position Control/Fully-closed Control Mode Adjustment

Use the following procedure to perform the adjustment in position control for the Servo Drive.

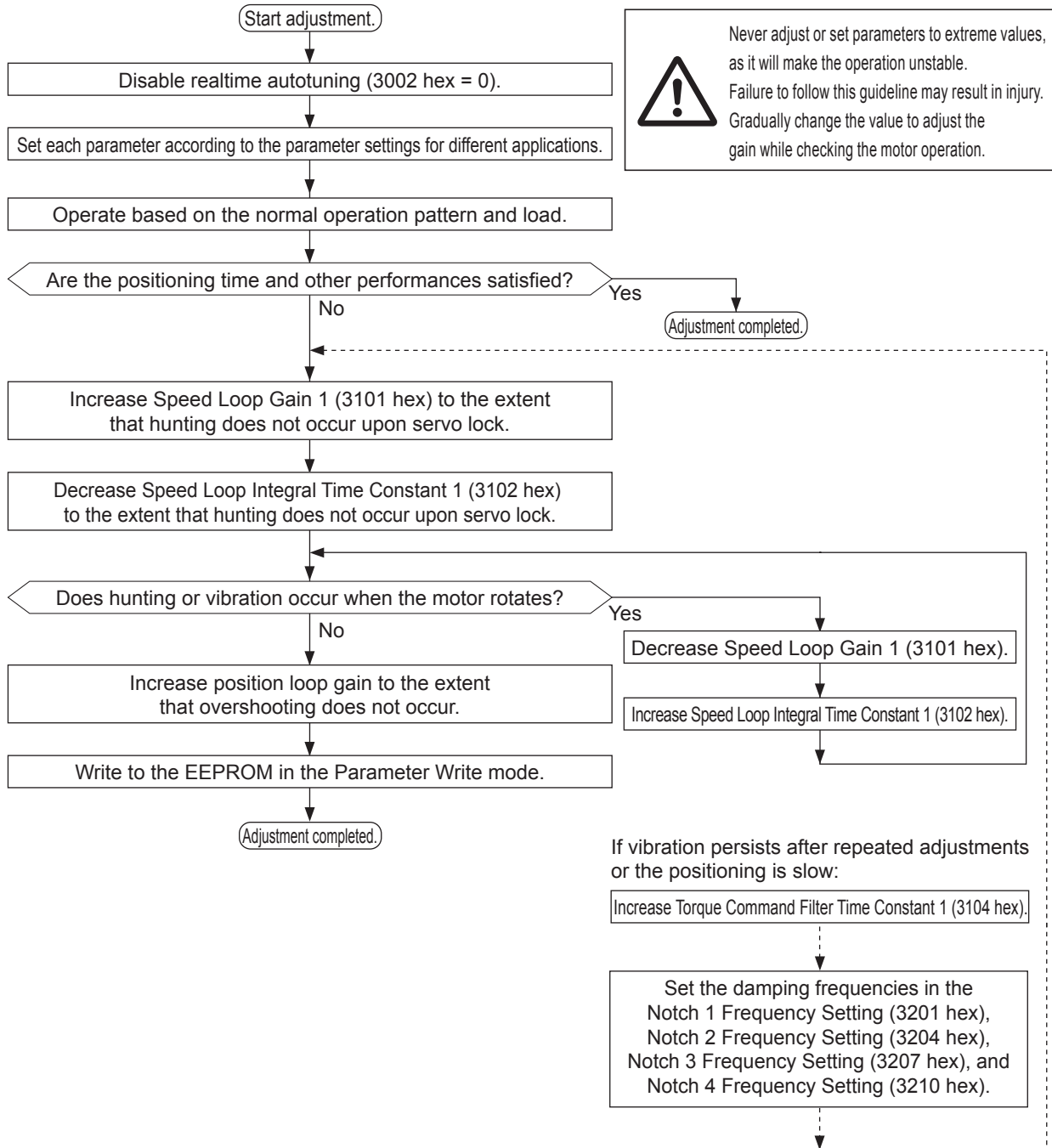

11-5 Damping Control

If the tip of the mechanical unit vibrates, you can use the damping control function to reduce vibration. This is effective on vibration generated by a machine of low rigidity. The applicable frequencies are from 1 to 200 Hz.

You can set four frequencies, and use two of them at the same time.

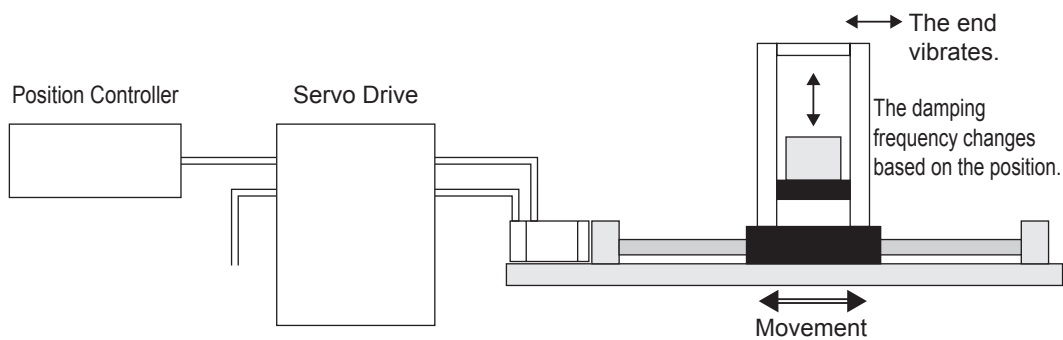

11-5-1 Objects Requiring Settings

Index	Name	Description	Reference
3213 hex	Damping Filter Selection	Select the Damping Filter Switching Mode according to the condition of the unit. 0: Up to two filters can be used simultaneously. 3: Switching with command direction.	page 9-23
3214 hex	Damping Frequency 1	Set damping frequency 1 to suppress vibration at the end of the load in damping control. If the damping control function is not used, set the damping frequency to a value between 0 and 0.9 [Hz].	page 9-23
3215 hex	Damping Filter 1 Setting	When Damping Frequency 1 (3214 hex) is set, reduce this setting if torque saturation occurs or increase this setting to increase operation speed. Normally 0 is set. If damping filter 1 is disabled, this object is also disabled.	page 9-23
3216 hex	Damping Frequency 2	The function is the same with 3214 hex.	page 9-23
3217 hex	Damping Filter 2 Setting	The function is the same with 3215 hex.	page 9-24
3218 hex	Damping Frequency 3	The function is the same with 3214 hex.	page 9-24
3219 hex	Damping Filter 3 Setting	The function is the same with 3215 hex.	page 9-24
3220 hex	Damping Frequency 4	The function is the same with 3214 hex.	page 9-24
3221 hex	Damping Filter 4 Setting	The function is the same with 3215 hex.	page 9-24



Precautions for Correct Use

- Stop operation before changing the objects or switching with DFSEL.
- Damping control may not function properly or the effect may not be apparent under the following conditions.

Item	Conditions under which the effect of damping control is inhibited
Load condition	<ul style="list-style-type: none"> • If forces other than position commands, such as external forces, cause vibration. • If the damping frequency is outside the range of 1.0 to 200 Hz. • If the ratio of the resonance frequency to anti-resonance frequency is large.

11-5-2 Operating Procedure

1 Adjust the position loop gain and speed loop gain.

Adjust Position Loop Gain 1 (3100 hex), Speed Loop Gain 1 (3101 hex), Speed Loop Integral Time Constant 1 (3102 hex), and Torque Command Filter Time Constant 1 (3104 hex).

If no problem occurs in realtime autotuning, you can continue to use the settings.

2 Measure the damping frequency at the tip of the mechanical unit.

Measure the damping frequency by using a measurement device such as a laser displacement sensor, servo acceleration meter, or acceleration pick-up.

Set the measured damping frequency in one of Damping Frequency 1 to Damping Frequency 4 (1: 3214 hex, 2: 3216 hex, 3: 3218 hex, 4: 3220 hex) according to the operation.

Also set the Switching Mode using Damping Filter Selection (3213 hex).

If the measurement device cannot be used, use CX-Drive tracing function, and read the residual damping frequency (Hz) from the position error waveform as shown in the following figure.

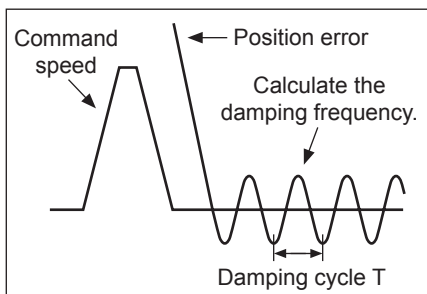

- The damping frequency in the figure is calculated with the following formula:

$$f \text{ (Hz)} = \frac{1}{T \text{ (s)}}$$

Since the object unit is 0.1 Hz:
 (3214 hex, 3216 hex, 3218 hex, 3220 hex) = 10 × f

- Application example
 If the damping cycle is 100 ms or 20 ms, set 100 or 500 in the object so that the damping frequency becomes 10 Hz or 50 Hz.

If vibration persists after setting the frequency, increase or decrease the resonance frequency to find a proper one with minimum vibration.

3 Make the damping filter settings.

Make damping filter settings (1: 3215 hex, 2: 3217 hex, 3: 3219 hex, 4: 3221 hex).

First, set the filter to 0 and check the torque waveform during operation.

The stabilization time can be reduced by setting a large value; however, torque ripple will increase at the command change point as shown in the following figure. Set a range that will not cause torque saturation under actual operation conditions. The effects of vibration suppression will be lost if torque saturation occurs.

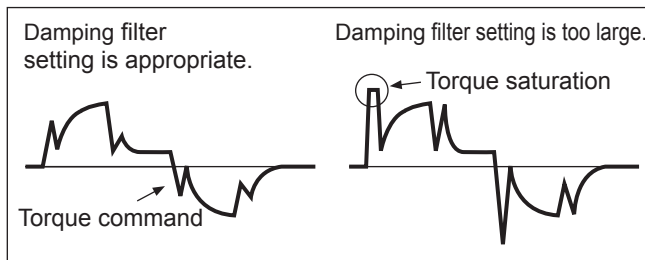

When setting the damping frequencies, reduce the setting if the torque become saturated and increase the setting to make operation faster. Normally 0 is set.

The setting range is as follows:

$$\begin{aligned} \text{Damping filter setting range: } & \text{Damping filter setting} \leq \text{Damping frequency} \\ & 100 \leq (\text{Damping frequency} + \text{Damping filter setting}) \end{aligned}$$

4 Set the Damping Filter Selection (3213 hex).

Damping filters 1 to 4 can be switched according to the conditions of the machine vibration.

Set value	Switching mode
0	Up to two filters, Damping Filter 1 and Damping Filter 2, can be used simultaneously.
1, 2	For use by manufacturer. Do not use this setting.
3	Switching with command direction Forward: Damping filter 1 and 3 enabled Reverse: Damping filter 2 and 4 enabled

11-6 Adaptive Filter

The adaptive filter reduces resonance point vibration by estimating the resonance frequency from the vibration component that appears in the motor speed during actual operation and automatically sets the frequency of the notch filter, which removes the resonance component from the torque command.

The automatically set notch filter frequency is set in Notch 3 (3207 to 3209 hex) or Notch 4 (3210 to 3212 hex). Refer to *11-7 Notch Filters* on page 11-23 for information on notch filter.

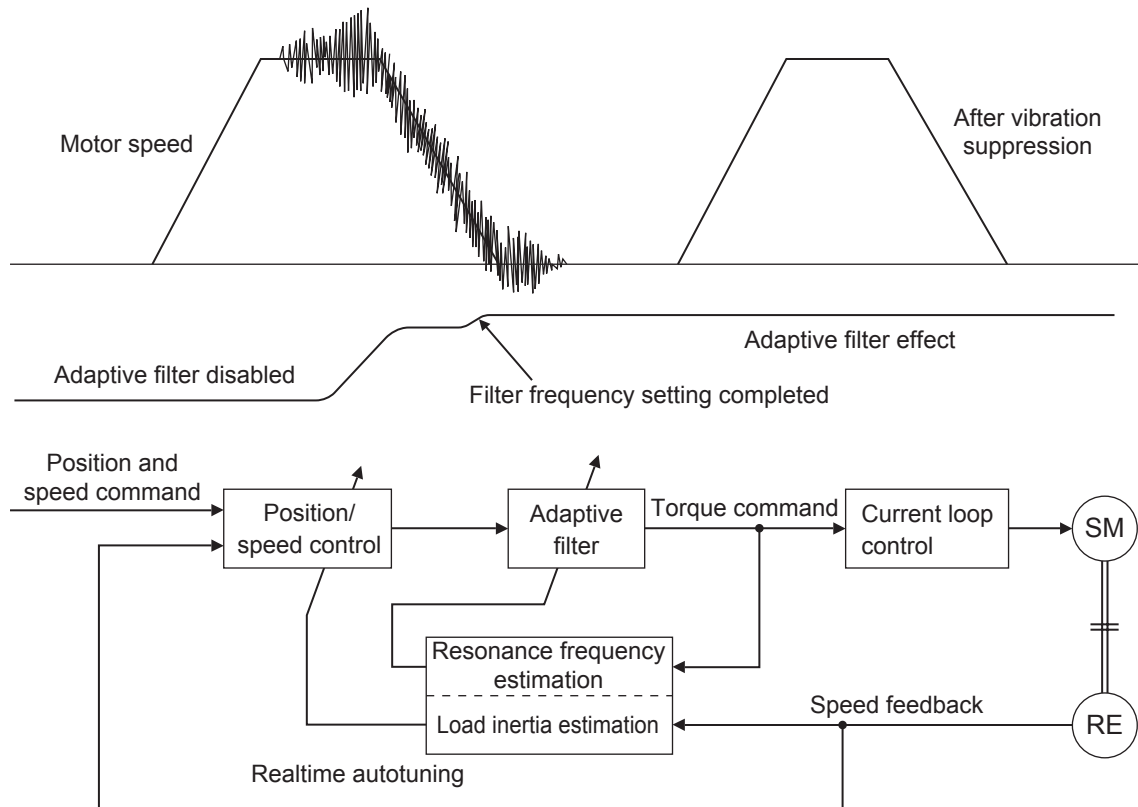

11-6-1 Objects Requiring Settings

Index	Name	Description	Reference
3200 hex	Adaptive Filter Selection	<p>Set the number of resonance frequencies to be estimated by the adaptive filter and the operation to be performed after estimation.</p> <p>0: Adaptive filter disabled.</p> <p>1: One adaptive filter enabled. The objects related to notch filter 3 are automatically updated.</p> <p>2: Two adaptive filters enabled. The objects related to notch filters 3 and 4 are automatically updated.</p> <p>3: For use by manufacturer. Do not use this setting.</p> <p>4: Adaptive result is cleared.</p> <p>Objects related to notch filters 3 and 4 are disabled and the adaptive result is cleared.</p>	page 9-20



Precautions for Correct Use

- Adaptive filter may not operate correctly under the following conditions.

Item	Conditions that interfere with the adaptive filter
Resonance points	<ul style="list-style-type: none"> If the resonance frequency is 300 Hz or lower. If the resonance peak or control gain is too low to affect the motor speed. If there are three or more resonance points.
Load	<ul style="list-style-type: none"> If the motor speed with high-frequency components changes due to backlash or other non-linear elements.
Command pattern	<ul style="list-style-type: none"> If the acceleration/deceleration is 3,000 r/min/s or higher.

- If the adaptive filter does not operate properly, use Notch 1 (3201 to 3203 hex) or Notch 2 (3204 to 3206 hex) to reduce resonance according to the manual adjustment procedure. Refer to *11-7 Notch Filters* on page 11-23 for information on notch filter.

11-6-2 Operating Procedure

1 Set the Adaptive Filter Selection (3200 hex).

Select adaptive filter 1 or 2 in the Adaptive Filter Selection (3200 hex).

2 Start actual operation.

Enter an operation command and start the actual operation.

3 The Notch Filters 3 and 4 are automatically set.

When the influence of a resonance point appears in the motor speed, the Notch Filters 3 and 4 objects are set automatically according to the number of adaptive filters.



Precautions for Correct Use

- An unusual noise or vibration may occur until the adaptive filter stabilizes after startup, immediately after the first servo ON, or when the Realtime Autotuning Machine Rigidity Selection (3003 hex) is increased. This is not a problem if it disappears right away. If the vibration or unusual noise, however, continues for three or more reciprocating operations, take the following measures in the possible order.
 - Write the objects used during normal operation to the EEPROM.
 - Lower the Realtime Autotuning Machine Rigidity Setting (3003 hex).
 - Disable the adaptive filter by setting the Adaptive Filter Selection (3200 hex) to 0. (Resetting of inertial estimation and adaptive operation)
 - Manually set the notch filter.
 - If unusual noise or vibration occurs, the setting of Notch 3 (3207 to 3209 hex) or Notch 4 (3210 to 3212 hex) may have changed to an extreme value. In this case, set Adaptive Filter Selection (3200 hex) to 0 to disable the object and then set the Notch 3 Frequency Setting (3207 hex) and Notch 4 Frequency Setting (3210 hex) to 5,000 (disabled). Next, enable Adaptive Filter Selection again.
 - The Notch 3 Frequency Setting (3207 hex) and Notch 4 Frequency Setting (3210 hex) are written to the EEPROM every 30 minutes. When the power supply is turned OFF and then turned ON again, this data is used as the default settings to perform adaptive operation.
-

11-7 Notch Filters

When the machine rigidity is low, axis torsion may produce resonance which results in vibration and noise. Thus you may not be able to set a high gain. The notch filter can restrict the resonance peak, and allows a high gain setting and vibration reduction.

The G5-series Servo Drives provide four notch filters that can be used for adjusting frequency, width and depth. If a ball screw or other controlled device causes resonance at a specific location, you can set the resonance frequency using a notch filter to eliminate resonance.

A notch filter is used to eliminate a specified frequency component.

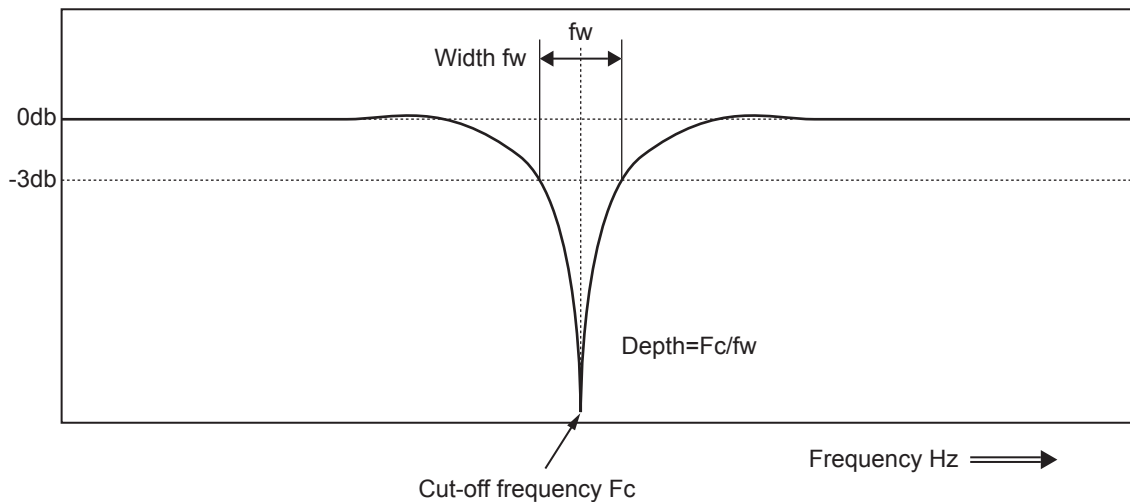

If machine resonance occurs, use this notch filter to eliminate resonance.

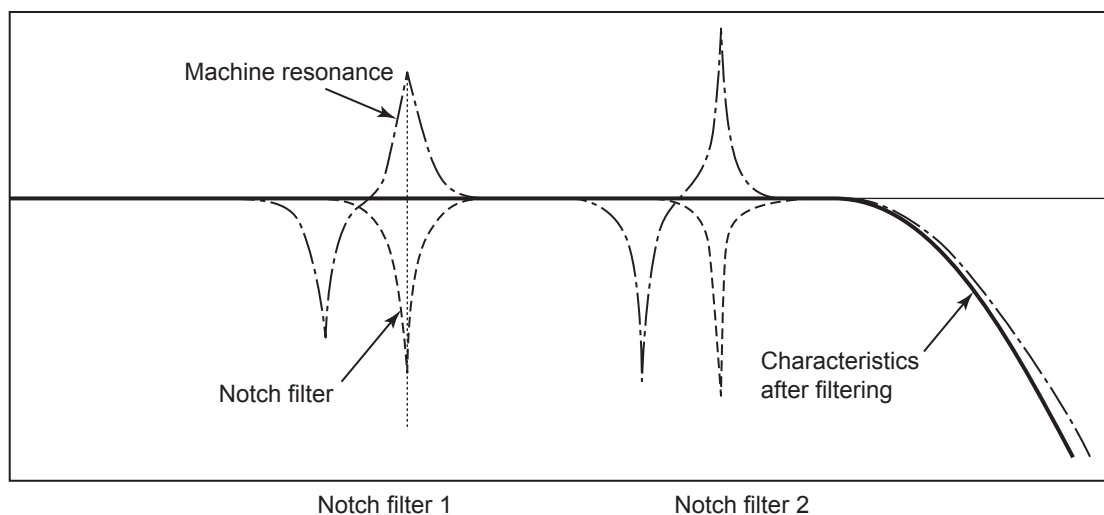

11-7-1 Objects Requiring Settings

Index	Name	Description	Reference
3201 hex	Notch 1 Frequency Setting	Set the center frequency of notch filter 1. The notch filter is enabled at 50 to 4,999 Hz, and disabled if 5,000 Hz is set.	page 9-20
3202 hex	Notch 1 Width Setting	Select the width of the notch filter 1 frequency. Increasing the value widens the notch width. (Setting range: 0 to 20)	page 9-20
3203 hex	Notch 1 Depth Setting	Select the depth of the notch filter 1 center frequency. Increasing the value decreases the notch depth and thereby reduces the phase delay. The notch filter is disabled if 100 is set. (Setting range: 0 to 99)	page 9-20
3204 hex	Notch 2 Frequency Setting	Set the center frequency of the notch filter 2. The details are the same with the notch filter 1 frequency.	page 9-21
3205 hex	Notch 2 Width Setting	Select the width of the notch filter 2 frequency. The details are the same with the notch filter 1 width.	page 9-21
3206 hex	Notch 2 Depth Setting	Select the depth of the notch filter 2 center frequency. The details are the same with the notch filter 1 depth.	page 9-21
3207 hex	Notch 3 Frequency Setting *1	Set the center frequency of the notch filter 3. The details are the same with the notch filter 1 frequency.	page 9-21
3208 hex	Notch 3 Width Setting *1	Select the width of the notch filter 3 frequency. The details are the same with the notch filter 1 width.	page 9-21
3209 hex	Notch 3 Depth Setting *1	Select the depth of the notch filter 3 center frequency. The details are the same with the notch filter 1 depth.	page 9-22
3210 hex	Notch 4 Frequency Setting *1	Set the center frequency of the notch filter 4. The details are the same with the notch filter 1 frequency.	page 9-22
3211 hex	Notch 4 Width Setting *2	Select the width of the notch filter 4 frequency. The details are the same with the notch filter 1 width.	page 9-22
3212 hex	Notch 4 Depth Setting *2	Select the depth of the notch filter 4 center frequency. The details are the same with the notch filter 1 depth.	page 9-22

*1 If an adaptive filter is used, these objects are set automatically.

*2 These objects are set automatically when two adaptive filters are enabled.



Precautions for Correct Use

- Identify the resonance frequency using the FFT analysis function or operation waveform of the waveform graphics function of CX-Drive and set the identified frequency as the notch filter frequency.

11-7-2 Notch Filter Width and Depth

Width Setting

This is the ratio of the frequency bandwidth at a damping factor of -3 [dB] relative to the center frequency when the depth is 0. This value should conform to the left column in the table below.

Depth Setting

This is the I/O ratio at which the center frequency input is completely cut off at a set value of 0 and completely passed at a set value of 100. If the indication unit is [dB], this value should conform to the right column in the table below.

Width	
Set value	Bandwidth/center frequency
0	0.50
1	0.59
2	0.71
3	0.84
4	1.00
5	1.19
6	1.41
7	1.68
8	2.00
9	2.38
10	2.83
11	3.36
12	4.00
13	4.76
14	5.66
15	6.73
16	8.00
17	9.51
18	11.31
19	13.45
20	16.00

Depth		
Set value	I/O ratio (%)	Damping factor (dB)
0	0 (Cut off)	$-\infty$
1	1	-40.0
2	2	-34.0
3	3	-30.5
4	4	-28.0
5	5	-26.0
10	10	-20.0
15	15	-16.5
20	20	-14.0
25	25	-12.0
30	30	-10.5
35	35	-9.1
40	40	-8.0
45	45	-6.9
50	50	-6.0
60	60	-4.4
70	70	-3.1
80	80	-1.9
90	90	-0.9
100	100 (Passed)	0.0

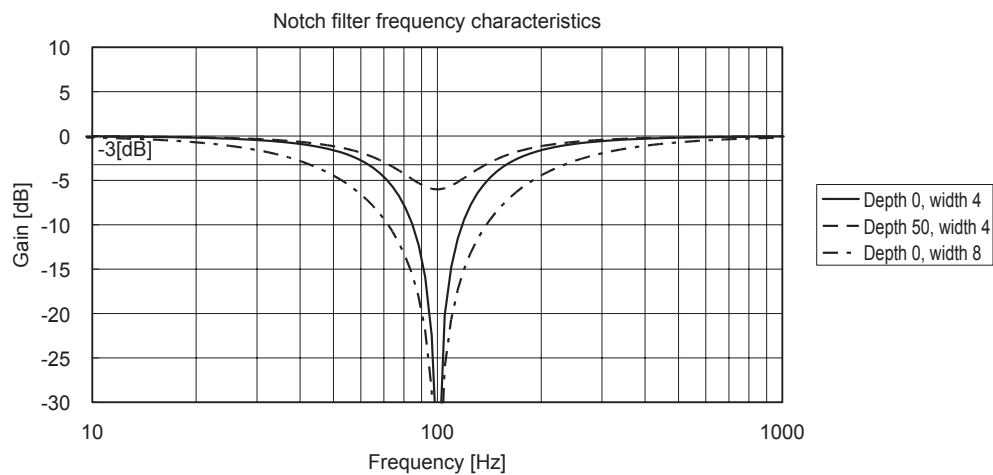

11-8 Disturbance Observer Function

You can lower the effect of the disturbance torque and reduce vibration by using the estimated disturbance torque value.

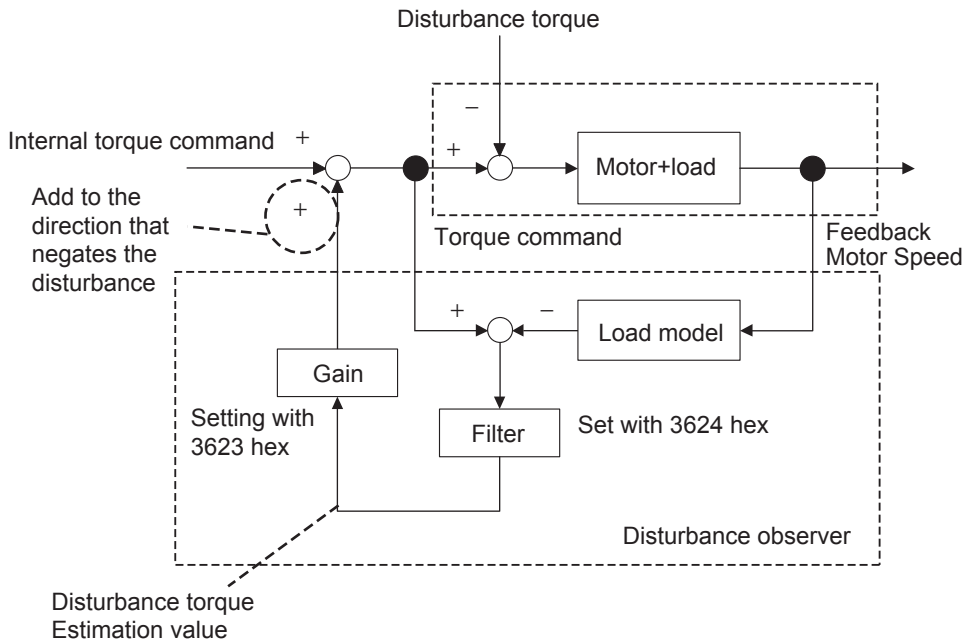

11-8-1 Operating Conditions

You can use the disturbance observer in the following situations.

	Conditions
Operating mode	Position control (semi-closed control), speed control
Others	<ul style="list-style-type: none"> • When Servo is ON. • When elements other than control parameters, such as the torque limit, are set correctly and there is no trouble with the motor's normal rotation. • When realtime autotuning function is disabled (3002 hex = 0). • When instantaneous speed observer function is disabled (3610 hex bit 0 = 0).



Precautions for Correct Use

- If there is a resonance point below the cut-off frequency estimated by the disturbance observer or if a large amount of high-frequency elements is found in the disturbance torque, the disturbance observer may not be effective.

11-8-2 Objects Requiring Settings

Index	Name	Description	Reference
3610 hex	Function Expansion Settings	Set the bits related to the disturbance observer.	page 9-48
3623 hex	Disturbance Torque Compensation Gain	Set the compensation gain for disturbance torque.	page 9-50
3624 hex	Disturbance Observer Filter Setting	Set the filter time constant for disturbance torque compensation.	page 9-50

11-8-3 Operating Procedure

- 1** Set the Function Expansion Setting (3610 hex).

Set whether to enable or disable the disturbance observer in bit 1.

 - 0: Disabled
 - 1: Enabled

Set the operating conditions for enabling the function in bit 2.

 - 0: Enabled at all time
 - 1: Enabled only when gain 1 is selected
- 2** Set the Disturbance Observer Filter Setting (3624 hex).

Set a small value for the Disturbance Torque Compensation Gain (3623 hex). Change the value in the Disturbance Observer Filter Setting (3624 hex) from a large value gradually to a smaller one. The smaller the value set of the Disturbance Observer Filter Setting (3624 hex) is, the lesser disturbance torque lag can be estimated, and the more effective control over the disturbance influence can be obtained. But the smaller the value is, the larger the operation noise can be. You must consider the balance of these advantage and disadvantage to set a value.
- 3** Set the Disturbance Torque Compensation Gain (3623 hex).

After you set the Disturbance Observer Filter Setting (3624 hex), increase the value of the Disturbance Torque Compensation Gain (3623 hex) from a small value to a large value. The larger the value set on the Disturbance Torque Compensation Gain (3623 hex) is, the more effective control over the disturbance influence can be obtained. But the larger the value is, the larger the operation noise will be. Set this object in combination with the Disturbance Observer Filter Setting (3624 hex) to achieve balanced settings.

11-9 Friction Torque Compensation Function

Two types of friction torque compensations can be set to reduce the influence of mechanical frictions. One is the unbalanced load compensation that offsets the constantly applied unbalance torque. The other is the dynamic friction compensation that changes the offset direction in accordance with the operating direction.

11-9-1 Operating Conditions

You can use the function under the following conditions:

Conditions
<ul style="list-style-type: none"> • When Servo is ON. • When elements other than control parameters, such as the torque limit, are set correctly and there is no trouble with the motor's normal rotation.

11-9-2 Objects Requiring Settings

The torque compensation function needs the combined settings of following three objects.

Index	Name	Description	Reference
3607 hex	Torque Command Value Offset	Set the unbalanced load compensation value that is always added to the internal torque command in the control mode other than torque control.	page 9-47
3608 hex	Forward Direction Torque Offset	Set the dynamic friction compensation value that is added to the internal torque command when a forward position command is input for position control or fully-closed control.	page 9-47
3609 hex	Reverse Direction Torque Offset	Set the dynamic friction compensation value that is added to the internal torque command when a reverse position command is input for position control or fully-closed control.	page 9-47

11-9-3 Operation Example

The friction torque compensation is applied in the input direction of the position command as shown in the drawing below.

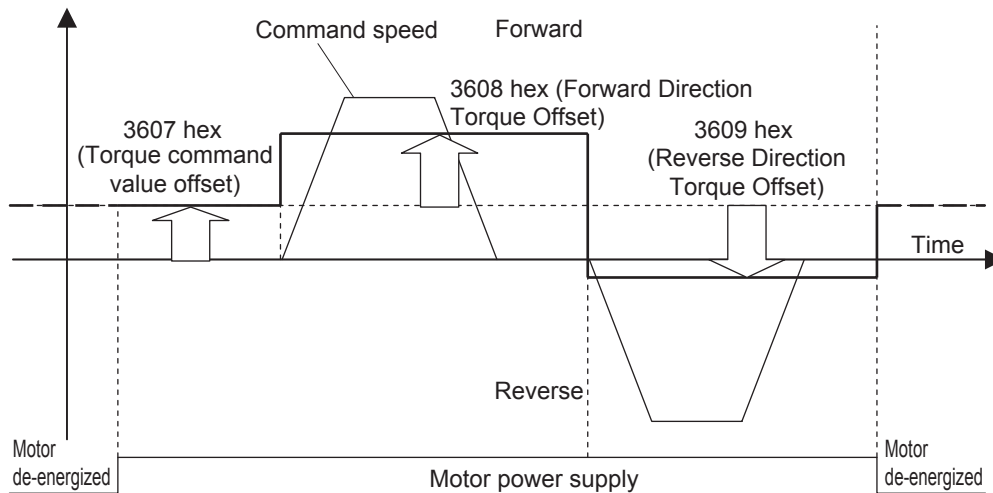

The Torque Command Value Offset (3607 hex) reduces the variations of positioning operations due to the movement directions when a certain amount of unbalanced load torque is always applied to the motor at the vertical axis by setting the torque command.

By setting the friction torque for each rotation direction in the Forward Direction Torque Offset (3608 hex) and Reverse Direction Torque Offset (3609 hex), you can reduce the deterioration of and inconsistencies in the positioning stabilization time due to dynamic friction for loads that require a large amount of dynamic friction torque due to a radial load, such as the belt-driven shaft.



Precautions for Correct Use

You can use the unbalanced load compensation and the dynamic friction compensation together or separately. Take note that the following use limit is applied upon control mode switching or servo ON.

- During Torque Control
The unbalanced load compensation and the dynamic friction compensation are 0 regardless of the object setting.
- When servo is OFF during speed control
The unbalanced load compensation is enabled based on 3607 hex. The dynamic friction compensation will be 0 regardless of the object setting.
- When the Servo Is Turned ON during Position Control or Fully-closed Control
The unbalanced load compensation and the dynamic friction compensation values are held until the first position command is input. When the position command is input, the unbalanced load compensation is updated based on 3607 hex. Also, based on the command direction, the dynamic friction compensation value is updated according to objects 3608 and 3609 hex.

11-10 Hybrid Vibration Suppression Function

This function suppresses the vibration that is caused by the amount of the torsion between the motor and the load in the Fully-closed Control Mode. You can use this function to increase the gain setting.

11-10-1 Operating Conditions

The hybrid vibration suppression function can be used in the following situations.

	Conditions
Operating mode	Fully-closed Control mode
Others	<ul style="list-style-type: none"> When Servo is ON. When elements other than control parameters, such as the torque limit, are set correctly and there is no trouble with the motor's normal rotation.

11-10-2 Objects Requiring Settings

Index	Name	Description	Reference
3634 hex	Hybrid Vibration Suppression Gain	Set the hybrid vibration suppression gain. In general, set it to the same value as the position loop gain, and finely adjust it based on the situation.	page 9-52
3635 hex	Hybrid Vibration Suppression Filter	Set the hybrid vibration suppression filter.	page 9-52

11-10-3 Operating Procedure

- 1 Set the Hybrid Vibration Suppression Gain (3634 hex) to the same value as the position loop gain.
- 2 Gradually increase the set value of the Hybrid Vibration Suppression Filter (3635 hex) while driving with fully-closed control and check the changes in the response.
If the response improves, find the combination of 3634 hex and 3635 hex that result in the optimal response by adjusting them.



Precautions for Correct Use

- This function is effective when the amount of torsion between the motor shaft and the load is large. It may be less effective when the amount of torsion is small.

11-11 Feed-forward Function

The feed-forward function come in 2 types: speed feed-forward and torque feed-forward.

The speed feed-forward can minimize the position error and increase the responsiveness during position or fully-closed control.

Responsiveness is improved by adding the speed feed-forward value calculated from the internal position command and related objects (3110 hex and 3111 hex) to the speed command calculated by comparing the internal position command and the position feedback.

If the Velocity offset (60B1 hex) is set, both the set value and the speed feed-forward valued are added to the Control effort (60FA hex).

The torque feed-forward can increase the responsiveness of the speed control system.

Responsiveness is improved by adding the torque feed-forward value calculated from the Control effort (60FA hex) and related objects (3112 hex and 3113 hex) to the torque command calculated by comparing the Control effort (60FA hex) and the speed feedback.

If the Torque offset (60B2 hex) is set, both the set value and the torque feed-forward valued are added to the torque command.

11-11-1 Objects Requiring Settings

Index	Name	Description	Reference
3110 hex	Speed Feed-forward Gain	The speed command from position control processing is added to the product of the Control effort (60FA hex) that is calculated from the internal position command times the ratio in this object.	page 9-10
3111 hex	Speed Feed-forward Command Filter	Set the time constant for the first-order lag filter that is applied to speed feed-forward input.	page 9-10
3112 hex	Torque Feed-forward Gain	The torque command from speed control processing is added to the product of the Control effort (60FA hex) times the ratio in this object.	page 9-10
3113 hex	Torque Feed-forward Command Filter	Set the time constant for the first-order lag filter that is applied to torque feed-forward input.	page 9-10
60B1 hex	Velocity offset	Set the offset for the speed command. It will be added to the Control effort (60FA hex).	page A-68
60B2 hex	Torque offset	Set the offset for the torque command. It will be added to the torque command value.	page A-68

11-11-2 Operating Procedure

Speed Feed-forward Operating Method

- 1 Set the Speed Feed-forward Command Filter (3111 hex).
Set it to approx. 50 (0.5 ms).

- 2 Adjust the Speed Feed-forward Gain (3110 hex).

Gradually increase the value of the Speed Feed-forward Gain (3110 hex) and finely adjust it to avoid overshooting during acceleration/deceleration.

If the speed feed-forward gain is set to 100%, the position error is calculated at 0. However, large overshooting will occur during acceleration/deceleration.

The position error during an operation at a certain speed will decrease based on the following formula according to the speed feed-forward gain value.

$$\text{Position error [command units]} = \text{Command speed [command units/s]} / \text{Position loop gain [1/s]} \times (100 - \text{Speed feed-forward gain [\%]}) / 100$$

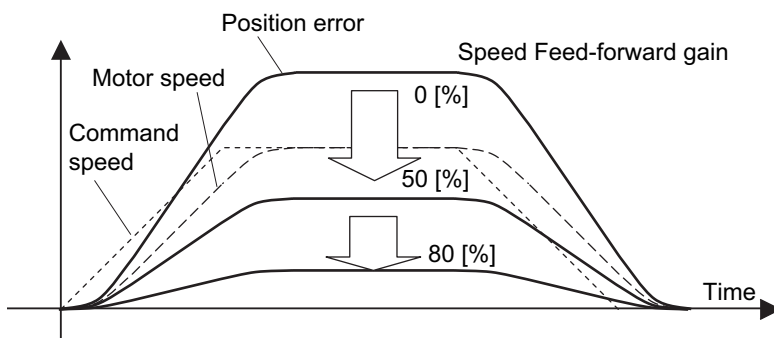

The position error in the range of constant speed becomes smaller as the speed feed-forward gain increases.



Precautions for Correct Use

- If the updating cycle of the position command input is longer than the Servo Drive control cycle, or if the input command frequency is not uniform, the operating noise may increase while the speed feed-forward is enabled. Apply the position command filter (first-order lag or FIR smoothing) or increase the speed feed-forward filter setting.

Torque Feed-forward Operating Method

1 Set the Inertia Ratio (3004 hex).

Set the inertia ratio as correctly as possible.

- If the inertia ratio is calculated for the selected motor, input the calculated value.
- If the inertia ratio is not known, perform autotuning and set the inertia ratio.

2 Set the Torque Feed-forward Command Filter (3113 hex).

Set it to approx. 50 (0.5 ms).

3 Adjust the Torque Feed-forward Gain (3112 hex).

Gradually increase the value of the Torque Feed-forward Gain (3112 hex).

Since the position error during acceleration/deceleration at a constant speed can be brought close to 0, it can be controlled almost to 0 throughout the entire operation range during a trapezoidal speed pattern under ideal conditions where no disturbance torque is working. In reality, disturbance torque is always applied and, therefore, the position error cannot be completely 0.

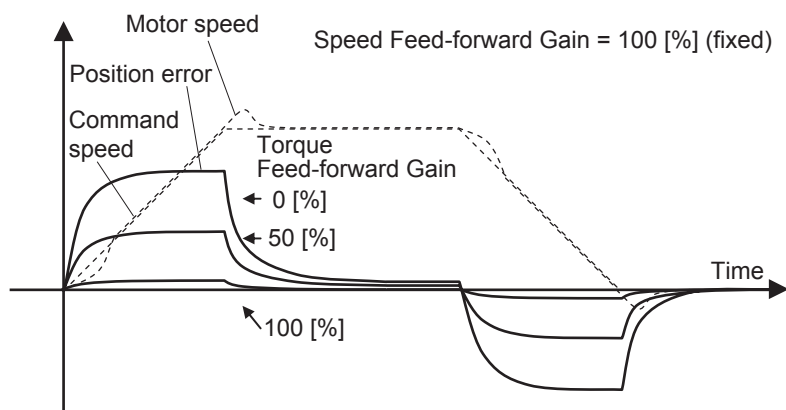

Torque feed-forward can reduce the position error in a range of constant acceleration/ deceleration.



Precautions for Correct Use

- If you increase the torque feed-forward filter time constant, the operation noise will be reduced. However, the position error where the acceleration changes will become larger.
- The torque feed-forward function cannot be used when realtime autotuning is being used. Set both the Torque Feed-forward Gain (3112 hex) and Torque Feed-forward Command Filter (3113 hex) to 0.

11-12 Instantaneous Speed Observer Function

This function uses a load model to estimate the motor speed. It improves the speed detection accuracy and can provide both high responsiveness and minimum vibration when stopping.

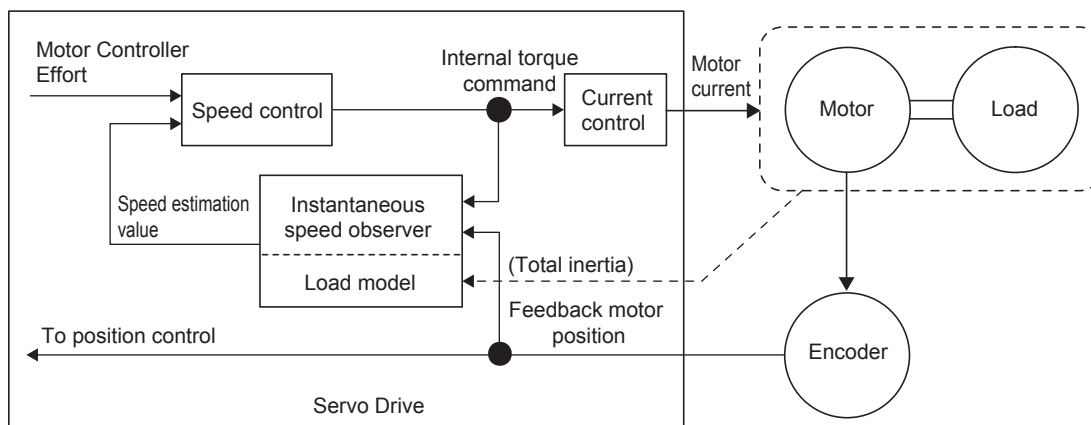

11-12-1 Operating Conditions

The instantaneous speed observer function can be used in the following situations.

	Conditions
Operating mode	Position control (semi-closed control) or speed control
Others	<ul style="list-style-type: none"> • When Servo is ON. • When elements other than control parameters, such as the torque limit, are set correctly and there is no trouble with the motor's normal rotation. • When realtime autotuning function is disabled (3002 hex = 0).

11-12-2 Objects Requiring Settings

Index	Name	Description	Reference
3610 hex	Function Expansion Settings	Set whether to enable or disable the instantaneous observer function.	page 9-48
3004 hex	Inertia Ratio	Set the inertia ratio.	page 9-4
3100 hex	Position Loop Gain 1	Set the position loop gain.	page 9-7
3101 hex	Speed Loop Gain 1	Set the speed loop gain.	page 9-8

11-12-3 Operating Procedure

1 Set the Inertia Ratio (3004 hex).

Set the inertia ratio as correctly as possible.

- If the Inertia Ratio (3004 hex) is obtained in realtime auto gain tuning, use the set value.
- If the inertia ratio is calculated for the selected motor, input the calculated value.
- If the inertia ratio is not known, perform autotuning and set the inertia ratio.

2 Adjust the position loop gain and speed loop gain.

Adjust Position Loop Gain 1 (3100 hex), Speed Loop Gain 1 (3101 hex), Speed Loop Integral Time Constant 1 (3102 hex), and Torque Command Filter Time Constant 1 (3104 hex).

If no problem occurs in realtime autotuning, you can continue to use the settings.

3 Set the Function Expansion Setting (3610 hex).

- Set whether to enable or disable the instantaneous speed observer function in bit 0. If you set this to 1 (enabled), the speed detection method switches to instantaneous speed observer.
- If the machine operation noise or vibration increases, or fluctuations in the torque monitor waveform increase significant enough to cause a problem, return the setting to 0 and make sure that the inertia ratio or the adjustment objects are correct.
- If the machine operation noise or vibration decreases, or fluctuations in the torque monitor waveform decrease, make small adjustments to the Inertia Ratio (3004 hex) to find the setting that makes the smallest fluctuations while monitoring the position error waveform and the actual speed waveform.
- If Position Loop Gain 1 (3100 hex), Speed Loop Gain 1 (3101 hex), or Speed Loop Integral Time Constant 1 (3102 hex) is changed, the optimal value for the Inertia Ratio (3004 hex) may change, so make small adjustments to the value of the Inertia Ratio (3004 hex) again to set a value that makes the smallest fluctuations.



Precautions for Correct Use

This function may not function properly or the effect may not be apparent under the following conditions.

- If there is a large resonance point at a frequency of 300 Hz or lower.
- If there is a non-linear element (play), such as a large backlash.
- If the load inertia changes.
- If there is a large disturbance torque with high-frequency elements applied.
- If the setting range for positioning is small.

12

Troubleshooting and Maintenance

This chapter describes the items to check when problems occur, troubleshooting using the error displays, troubleshooting based on the operating conditions, and periodic maintenance.

12-1 Troubleshooting	12-2
12-1-1 Preliminary Checks When a Problem Occurs	12-2
12-1-2 Precautions When a Problem Occurs	12-3
12-1-3 Replacing the Servomotor or Servo Drive	12-3
12-2 Warnings	12-5
12-2-1 Related Objects	12-5
12-2-2 Warning List	12-6
12-3 Errors	12-9
12-3-1 Error List	12-9
12-3-2 Immediate Stop Operation at Errors	12-12
12-4 Troubleshooting	12-14
12-4-1 Troubleshooting with Error Displays	12-14
12-4-2 Troubleshooting with the AL Status Code	12-29
12-4-3 Troubleshooting Using the Operation State	12-30
12-5 Periodic Maintenance	12-36
12-5-1 Servomotor Life Expectancy	12-36
12-5-2 Servo Drive Life Expectancy	12-37
12-5-3 Replacing the Absolute Encoder Battery	12-38

12-1 Troubleshooting

12-1-1 Preliminary Checks When a Problem Occurs

This section explains the preliminary checks required to determine the cause of a problem if one occurs.

Checking the Power Supply Voltage

- Check the voltage at the power supply input terminals.

Main Circuit Power Supply Input Terminals (L1, L2, L3)

R88D-KN□L-ECT	(50 W to 400 W)	:Single-phase 100 to 120 VAC (85 to 132 V) 50/60 Hz
R88D-KN□H-ECT	(100 W to 1.5 kW)	:Single-phase 200 to 240 VAC (170 to 264 V) 50/60 Hz
	(750 W to 1.5 kW)	:3-phase 200 to 240 VAC (170 to 264 V) 50/60 Hz
	(2 kW to 15 kW)	:3-phase 200 to 230 VAC (170 to 253 V) 50/60 Hz
R88D-KN□F-ECT	(750 W to 15 kW)	:3-phase 380 to 480 VAC (323 to 528 V) 50/60 Hz

Control Circuit Power Supply Input Terminals (L1C, L2C)

R88D-KN□L-ECT	(50 W to 400 W)	:Single-phase 100 to 120 VAC (85 to 132 V) 50/60 Hz
R88D-KN□H-ECT	(100 W to 1.5 kW)	:Single-phase 200 to 240 VAC (170 to 264 V) 50/60 Hz
	(2 kW to 15 kW)	:3-phase 200 to 230 VAC (170 to 253 V) 50/60 Hz
R88D-KN□F-ECT	(750 W to 15 kW)	:24 VDC (21.6 to 26.4 V)

If the voltage is out of range, there is a risk of operation failure. Be sure that the power supply is within the specified range.

- Check the voltage of the sequence input power supply (+24 VIN terminal (CN1 pin 7)). It must be between 11 and 25 VDC.
If the voltage is out of range, there is a risk of operation failure. Be sure that the power supply is within the specified range.

Checking Whether an Error Has Occurred

- Make an analysis using the 7-segment display on the front of the Servo Drive or using CX-Drive tools.
- When an Error Has Occurred
 - ... Check the error display (□□) and make an analysis based on the error that is indicated.
- When an Error Has Not Occurred
 - ... Make an analysis according to the error conditions.
- In either case, refer to *12-4 Troubleshooting* on page 12-14 for details.

12-1-2 Precautions When a Problem Occurs

When checking and verifying I/O after a problem has occurred, the Servo Drive may suddenly start to operate or suddenly stop, so always take the following precautions.

You should assume that anything not described in this manual is not possible with this product.

Precautions

- Disconnect the wiring before checking for cable breakage. If you test conduction with the cable connected, test results may not be accurate due to conduction via bypassing circuit.
- If the encoder signal is lost, the motor may run away, or an error may occur. Be sure to disconnect the motor from the mechanical system before checking the encoder signal.
- When measuring the encoder output, perform the measurement based on the GND (CN1 pin 16). When an oscilloscope is used for measurement, it will not be affected by noise if measurements are performed using the differential between CH1 and CH2.
- When performing tests, first check that there are no persons in the vicinity of the equipment, and that the equipment will not be damaged even if the motor runs away. Before performing the tests, verify that you can immediately stop the machine using an immediate stop in case the machine runs out of control.

12-1-3 Replacing the Servomotor or Servo Drive

Use the following procedure to replace the Servomotor or Servo Drive.

Replacing the Servomotor

- 1** Replace the motor.
- 2** Perform origin adjustment (for position control).
 - When the motor is replaced, the motor's origin position (phase Z) may deviate, so origin adjustment must be performed.
 - Refer to the position controller's manual for details on performing origin adjustment.
- 3** Set up the absolute encoder.
 - If a motor with an absolute encoder is used, the absolute value data in the absolute encoder is cleared when the motor is replaced, so setup is again required. The multi-rotation data will be different from before it was replaced, so initialize the Motion Control Unit settings.
 - For details, refer to *10-2-4 Absolute Encoder Setup* on page 10-7.

Replacing the Servo Drive

1 Take a record of all object settings.

Use the CX-Drive or other software and take a record of the settings of all objects.

2 Replace the Servo Drive.

3 Set the objects.

Use the CX-Drive or other software and set all of the objects.

4 Set up the absolute encoder.

- If a motor with an absolute encoder is used, the absolute value data in the absolute encoder is cleared when the Servo Drive is replaced, so setup is again required. The multi-rotation data will be different from before it was replaced, so initialize the Motion Control Unit settings.
- For details, refer to *10-2-4 Absolute Encoder Setup* on page 10-7.

12-2 Warnings

This function outputs a warning signal and notifies state such as an overload before an error occurs. Set whether to hold warning state by setting the Warning Hold Selection (3759 hex).

If not holding warnings is selected, a warning will be cleared automatically when the cause of the warning has been eliminated. If holding warnings is selected, the normal procedure to clear errors must be performed after removing the cause of the error.

Battery warnings, however, are held in the encoder. The error will be cleared once the hold state has been cleared in the encoder.

12-2-1 Related Objects

Index	Name	Description	Reference
3440 hex	Warning Output Selection 1	Select the warning for Warning Output 1 (WARN1). 0: Output for all warnings. 1 or higher: Refer to <i>12-2-2 Warning List</i> on page 12-6.	page 9-40
3441 hex	Warning Output Selection 2	Select the warning for Warning Output 2 (WARN2). 0: Output for all warnings. 1 or higher: Refer to <i>12-2-2 Warning List</i> on page 12-6.	page 9-40
3638 hex	Warning Mask Setting	Set a mask for warning detection. If you set the corresponding bit to 1, the detection of the corresponding warning is disabled. Refer to <i>12-2-2 Warning List</i> on page 12-6.	page 9-53
3759 hex	Bit 0	Warning Hold Selection for Communications-related Warnings Select whether to hold servo-related and communications-related warning state. 0: Do not hold 1: Hold	page 9-56
	Bit 1		
3800 hex	Communications Control	Controls errors and warnings related to EtherCAT communications. If you set the corresponding bit to 1, the detection of the corresponding warning is disabled.	page 9-57

12-2-2 Warning List

General Warnings

Warning number	Warning name	Warning condition	Warning Hold Selection (3759 hex) ^{*1}	Warning Output Selection (3440 hex, 3441 hex) ^{*2}	Warning Mask Setting (3638 hex) ^{*3}
A0 hex	Overload Warning	The load ratio is 85% or more of the protection level.	√	1	Bit 7
A1 hex	Excessive Regeneration Warning	The regeneration load ratio is 85% or more of the level.	√	2	Bit 5
A2 hex	Battery Warning ^{*4}	The battery voltage is 3.2 V or less.	Fixed to Hold	3	Bit 0
A3 hex	Fan Warning	The fan stop state continues for 1 second.	√	4	Bit 6
A4 hex	Encoder Communications Warning	The encoder communications errors occurred in series more frequently than the specified value.	√	5	Bit 4
A5 hex	Encoder Overheating Warning ^{*5}	The encoder detects the overheat warning.	√	6	Bit 3
A6 hex	Vibration Detection Warning	Vibrating is detected.	√	7	Bit 9
A7 hex	Life Expectancy Warning	The life expectancy of the capacitor or the fan is shorter than the specified value.	Fixed to Hold	8	Bit 2
A8 hex	External Encoder Error Warning	The external encoder detects a warning.	√	9	Bit 8
A9 hex	External Encoder Communications Warning	The external encoder has communications errors in series more than the specified value.	√	10	Bit 10

*1 The √ in above column means that you can use the Warning Hold Selection (3759 hex) to change between Do not hold (hold for 1 second) and Hold. The Battery Warning and Life Expectancy Warning are fixed to Hold.

*2 Set the Warning Output Selection 1 (3440 hex) to the warning type to output to Warning Output 1 (WARN1), and set the Warning Output Selection 2 (3441 hex) to the warning type to output to the Warning Output 2 (WARN2). If you set these objects to 0, all warning types are output.

*3 Detection of general warnings can be masked with the Warning Mask Setting (3638 hex) and detection of EtherCAT communications-related warnings can be masked with the Communications Control (3800 hex). When the bit is set to 1, the warning detection is masked.

*4 If you replace the Battery while the control circuit power is ON, the warning status will remain held. If you want to reset the warning without cycling the power supply, use Error Reset (4107 hex) after you replace the Battery to reset the warning.

*5 The encoder overheating warning is enabled only when using a 20-bit incremental encoder. It is disabled for all other types of encoders.

**Precautions for Correct Use**

- Do not use any settings for Error Output Selection 1 (3440 hex) and Error Output Selection 2 (3441 hex) other than those given in the above table.
- You can clear these warnings by executing the error rest command. The command does clear the warning even if the cause of the warning is not removed, but the same warning will occur again.

Warnings Related to EtherCAT Communications

Warning number	Warning name	Warning condition	Warning Hold Selection (3759 hex) *1	Warning Output Selection (3440 hex, 3441 hex) *1	Warning Mask Setting (3800 hex) *2
B0 hex	Data Setting Warning	<ul style="list-style-type: none"> • An object setting is out of range. 	√	11	Bit 4
B1 hex	Command Warning	<p>Object operating conditions are not satisfied.</p> <ul style="list-style-type: none"> • A forced brake operation request was sent while the servo was ON. • A Switch ON command was sent when the main circuit power supply was OFF and object 3508 hex = 0. • An Enable Operation command was sent to request turning ON the servo when the Servomotor was operating at 30 r/min or higher. • An Enable Operation command was sent to request turning ON the servo when Modes of operation (6060 hex) was not set. <p>A latch operation was started under the following conditions.</p> <ul style="list-style-type: none"> • An absolute external encoder was used and phase Z was selected as the trigger for fully-closed control. • During Homing mode • The absolute multi-rotation data is being cleared or the Config operation is being performed. • The Statusword (6041 hex) bit 9 (remote) is 0 (local). <p>An operation command was applied in the drive-prohibited direction after an immediate stop for a drive prohibition input.</p>	√	12	Bit 5
B2 hex	EtherCAT Communications Warning *3	EtherCAT communications errors occurred one or more times.	√	13	Bit 6

- *1 Set the Warning Output Selection (3440 hex) to the warning type to output to Warning Output 1 (WARN1), and set Warning Output Selection 2 (3441 hex) to the warning type to output to Warning Output 2 (WARN2). If you set these objects to 0, all warning types are output.
- *2 Detection of general warnings can be masked with the Warning Mask Setting (3638 hex) and detection of EtherCAT communications-related warnings can be masked with the Communications Control (3800 hex). The warning detection is masked when you set the corresponding bit to 1.
- *3 This warning can also occur when the power supply to the master is turned OFF while EtherCAT communications are established. Therefore, if you turn OFF the power supply to the master and then immediately turn OFF the power supply to the G5-series Servo Drive, an event may be saved in the error history.



Precautions for Correct Use

Do not use any settings for Error Output Selection 1 (3440 hex) and Error Output Selection 2 (3441 hex) other than those given in the above table.

12-3 Errors

If the Servo Drive detects an abnormality, it outputs an error (ALM), turns OFF the power drive circuit, and displays the main error number on the front panel.



Precautions for Correct Use

- Refer to *12-4-1 Troubleshooting with Error Displays* on page 12-14 for troubleshooting errors.
- Reset the error using one of the following methods. Remove the cause of the error first.
 - Turn OFF the power supply, then turn it ON again.
 - Reset the error via EtherCAT communications or from the CX-Drive via USB communications.

However, some errors can only be reset by turning the power supply OFF then ON again. Refer to the *12-3-1 Error List* on page 12-9.

- An Overload Error (Error No. 16.0) cannot be reset for 10 seconds after it occurs.
- If “hh,” “FF,” or “HH” is displayed as the error number, the internal MPU has malfunctioned. Turn OFF the power immediately if one of these error numbers is displayed.

12-3-1 Error List

Error No. (hex)		Error detection function	Attribute		
Main	Sub		History	Can be reset	Immediate stop ^{*1}
11	0	Control Power Supply Undervoltage	–	√	–
12	0	Overvoltage	√	√	–
13	0	Main Power Supply Undervoltage (insufficient voltage between P and N)	–	√	–
	1	Main Power Supply Undervoltage (AC cutoff detected)	–	√	–
14	0	Overcurrent	√	–	–
	1	IPM Error	√	–	–
15	0	Servo Drive Overheat	√	–	√
16	0	Overload	√	√ ^{*2}	–
18	0	Regeneration Overload	√	–	√
	1	Regeneration Tr Error	√	–	–
21	0	Encoder Communications Disconnection Error	√	–	–
	1	Encoder Communications Error	√	–	–
23	0	Encoder Communications Data Error	√	–	–
24	0	Error Counter Overflow	√	√	√
	1	Excessive Speed Deviation Error	√	√	√
25	0	Excessive Hybrid Deviation Error	√	–	√
26	0	Overspeed	√	√	√
	1	Overspeed 2	√	√	–

Error No. (hex)		Error detection function	Attribute		
Main	Sub		History	Can be reset	Immediate stop ^{*1}
27	1	Absolute Value Cleared ABS	√	–	–
	4	Command Error	√	–	–
	5	Command Generation Error	√	–	–
	6	Operation Command Duplicated	√	√	–
	7	Position Data Initialized	–	√	–
29	1	Error Counter Overflow 1 ABS	√	–	–
	2	Error Counter Overflow 2	√	–	–
30 (st)	0	Safety Input Error	–	√	–
33	0	Interface Input Duplicate Allocation Error 1	√	–	–
	1	Interface Input Duplicate Allocation Error 2	√	–	–
	2	Interface Input Function Number Error 1	√	–	–
	3	Interface Input Function Number Error 2	√	–	–
	4	Interface Output Function Number Error 1	√	–	–
	5	Interface Output Function Number Error 2	√	–	–
	8	External Latch Input Allocation Error	√	–	–
34	0	Overrun Limit Error	√	√	–
36	0 to 2	Object Error	–	–	–
37	0 to 2	Object Corrupted	–	–	–
38	0	Drive Prohibition Input Error 1	–	√	–
	1	Drive Prohibition Input Error 2	–	√	–
40	0	Absolute Encoder System Down Error ABS	√	√ ^{*3}	–
41	0	Absolute Encoder Counter Overflow Error ABS	√	–	–
42	0	Absolute Encoder Overspeed Error ABS	√	√ ^{*3}	–
43	0	Encoder Initialization Error	√	–	–
44	0	Absolute Encoder 1-rotation Counter Error ABS	√	–	–
45	0	Absolute Encoder Multi-rotation Counter Error ABS	√	–	–
47	0	Absolute Encoder Status Error ABS	√	–	–
48	0	Encoder Phase-Z Error	√	–	–
49	0	Encoder CS Signal Error	√	–	–
50	0	External Encoder Connection Error	√	–	–
	1	External Encoder Communications Data Error	√	–	–
51	0	External Encoder Status Error 0	√	–	–
	1	External Encoder Status Error 1	√	–	–
	2	External Encoder Status Error 2	√	–	–
	3	External Encoder Status Error 3	√	–	–
	4	External Encoder Status Error 4	√	–	–
	5	External Encoder Status Error 5	√	–	–
55	0	Phase-A Connection Error	√	–	–
	1	Phase-B Connection Error	√	–	–
	2	Phase-Z Connection Error	√	–	–

Error No. (hex)		Error detection function	Attribute		
Main	Sub		History	Can be reset	Immediate stop ^{*1}
83	1	EtherCAT State Change Error	√	√ ^{*4}	–
	2	EtherCAT Illegal State Change Error	√	√ ^{*4}	–
	3	Communications Synchronization Error	√	√ ^{*5}	–
	4	Synchronization Error	√	√ ^{*4}	–
	5	Sync Manager WDT Error	√	√ ^{*4}	–
87	0	Immediate Stop Input Error	–	√	–
88	0	Node Address Setting Error	√	–	–
	1	ESC Initialization Error	√	–	–
	2	Interruptions Error	√	–	–
	3	SII Verification Error	√	–	–
90	0	Communications Setting Error	√	√ ^{*4}	–
91	1	Command Error	√	√	–
92	0	Encoder Data Restoration Error	√	–	–
	1	External Encoder Data Restoration Error	√	–	–
93	0	Object Setting Error 1	√	–	–
	2	Object Setting Error 2	√	–	–
	3	External Encoder Connection Error	√	–	–
	4	Function Setting Error	√	√	–
95	0 to 4	Motor Non-conformity	–	–	–
99	0	Other errors	√	–	–
Other numbers			√	–	–

*1 An immediate stop error is displayed if an immediate stop is performed when –4 to –7 is set for the Fault reaction option code (605E hex). Refer to the description of object 605E hex on page A-60.

*2 This error cannot be reset for 10 seconds after it occurs.

*3 The error cannot be reset unless the absolute value is cleared.

*4 This error cannot be reset until the cause of the error is removed by performing an operation from the master. When resetting the error via a USB connection, remove the cause of the error beforehand via the master.

*5 This error cannot be reset until the cause of the error is removed by performing an operation from the master. Reset the error from the CX-Drive connected to the PLC and from the ladder diagram. The error cannot be reset from the CX-Drive via USB communications.

Note 1 If an error that cannot be reset occurs, remove the error factor and turn OFF the control power to reset the error.

2 If a resettable error occurs, reset the error via EtherCAT communications or on the CX-Drive.

3 If “hh,” “FF,” or “HH” is displayed as the error number, the internal MPU has malfunctioned. Turn OFF the power immediately if one of these error numbers is displayed.

12-3-2 Immediate Stop Operation at Errors

The immediate stop function controls the motor and stop it immediately if an error that supports for immediate stopping occurs.

Related Objects

Index	Name	Explanation	Reference
605E hex	Fault reaction option code	Set the state during deceleration and after stopping for when an error occurs.	page A-60
3511 hex	Immediate Stop Torque	Set the torque limit for immediate stops.	page 9-43
3513 hex	Overspeed Detection Level Setting	If the motor rotation speed exceeds the set value, an Overspeed Error (Error No. 26.0) will occur.	page 9-43
3614 hex	Error Detection Allowable Time Setting	Set the allowable time until stopping if an immediate stop is executed when an error is detected.	page 9-49
3615 hex	Overspeed Detection Level Setting at Immediate Stop	If the motor speed exceeds the set value during an immediate stop resulting from an error, an Overspeed 2 Error (Error No. 26.1) will occur.	page 9-49

Immediate Stop Operation

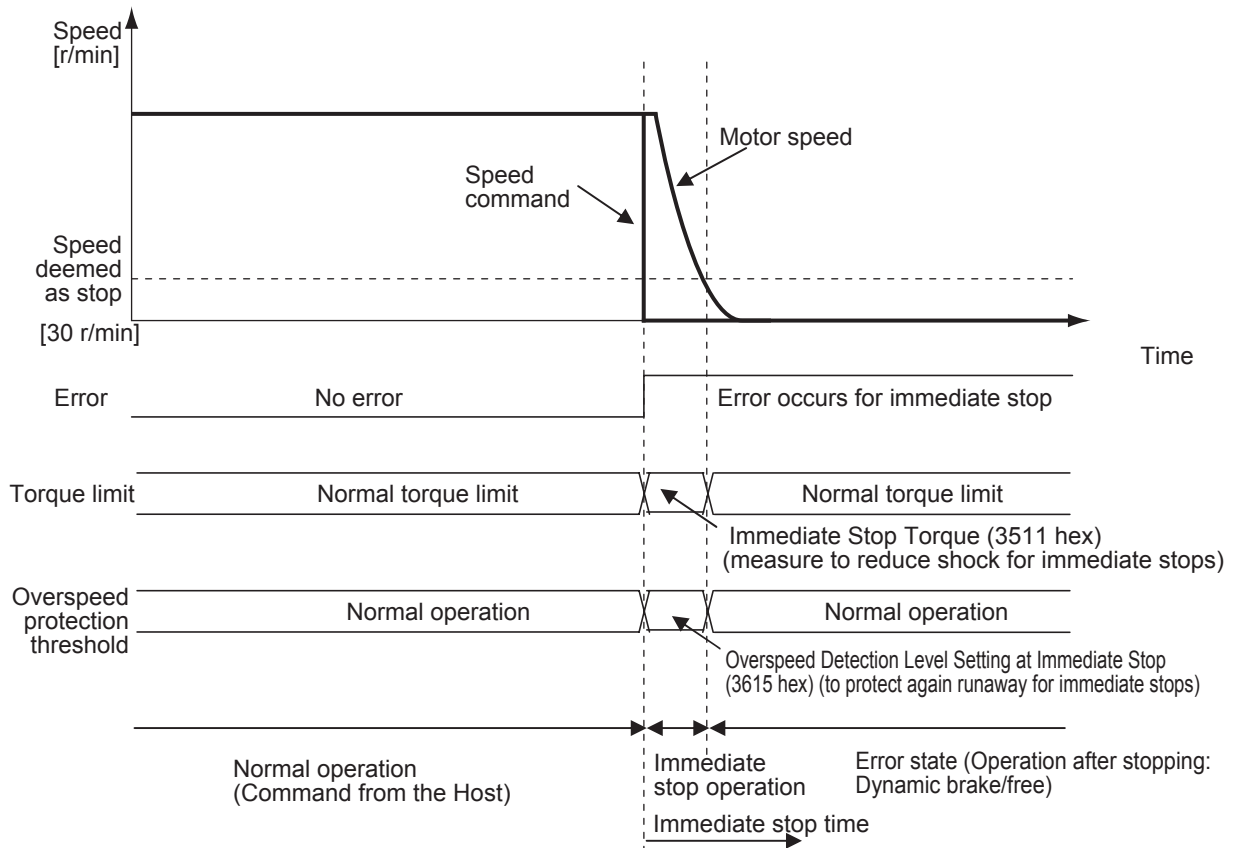

Precautions for Correct Use

- To prevent operation from running out of control for an immediate stop, set the allowable Overspeed Detection Level Setting at Immediate Stop (3615 hex). An Overspeed 2 Error (Error No. 26.1) does not support immediate stopping. If it occurs, an error trip will occur immediately.
- Set a higher value for the Overspeed Detection Level Setting at Immediate Stop (3615 hex) than for the Overspeed Detection Level Setting (3513 hex). If a value lower than the Overspeed Detection Level Setting (3513 hex) is set, an Overspeed 2 Error (Error No. 26.1) will occur before an Overspeed Error (Error No. 26.0). Thus an immediate stop will not occur. If an Overspeed Error (Error No. 26.0) and an Overspeed 2 error (Error No. 26.1) occur at the same time, the immediate stop will not occur, either.
- If the actual rotation speed is not lower than 30 r/min after the time set on the Error Detection Allowable Time Setting (3614 hex) elapses from when an error that supports immediate stopping occurs, an error state will occur immediately.
- If an error that does not support immediate stopping occurs during an immediate stop, an error state will occur immediately.

12-4 Troubleshooting

If an error occurs in the machine, determine the error conditions from the error displays and operation state, identify the cause of the error, and take appropriate measures.

12-4-1 Troubleshooting with Error Displays

Error List

Error No. (hex)		Name	Cause	Measures
Main	Sub			
11	0	Control Power Supply Undervoltage	<p>The voltage between the positive and negative terminals in the control power supply converter dropped below the specified value.</p> <p>100-V products: Approx. 70 VDC (Approx. 50 VAC) 200-V products: Approx. 145 VDC (Approx. 100 VAC) 400-V products: Approx. 15 VDC</p> <ul style="list-style-type: none"> • The power supply voltage is low. A momentary power interruption occurred. • Insufficient power supply capacity: the power supply voltage dropped because there was inrush current when the main power supply was turned ON. • The Servo Drive is faulty (circuit fault). 	<p>Measure the voltage between the L1C and L2C lines on the connectors and the terminal block.</p> <ul style="list-style-type: none"> • Increase the power supply voltage. Change the power supply. • Increase the power supply capacity. • Replace the Servo Drive.
12	0	Overvoltage	<p>The power supply voltage exceeded the allowable input voltage range, causing the voltage between the positive and negative terminals in the converter to exceed the specified value. The power supply voltage is high. The voltage was suddenly increased by the phase advance capacitor or the uninterruptible power supply (UPS).</p> <p>100-V products: Approx. 200 VDC (Approx. 140 VAC) 200-V products: Approx. 400 VDC (Approx. 280 VAC) 400-V products: Approx. 800 VDC (Approx. 560 VAC)</p> <ul style="list-style-type: none"> • The Regeneration Resistor wiring is broken. • The External Regeneration Resistor is inappropriate and cannot absorb all of the regenerative energy. The load inertia is too large, gravitational torque on the vertical axis is too large, or there is some other problem to absorb the regenerative energy. • The Servo Drive is faulty (circuit fault). 	<p>Measure the voltage between the connector (L1, L2, and L3) lines. Input the correct voltage. Remove the phase advance capacitor.</p> <ul style="list-style-type: none"> • Use a tester to measure the resistance of the external resistor between the B1 and B2 terminals on the Servo Drive. If the resistance is infinite, the wiring is broken. Replace the external resistor. • Change the regeneration resistance and wattage to the specified values. (Calculate the regenerative energy and connect an External Regeneration Resistor with the required regeneration absorption capacity. Reduce the descent speed.) • Replace the Servo Drive.

Error No. (hex)		Name	Cause	Measures
Main	Sub			
13	0	Main Circuit Power Supply Undervoltage (Undervoltage between positive and negative terminals)	<p>If the Undervoltage Error Selection (3508 hex) is set to 1, a momentary power interruption occurred between L1 and L3 for longer than the value specified for the Momentary Hold Time (3509 hex). Alternatively, the voltage between the positive and negative terminals in the main power supply converter dropped below the specified value while the servo was ON.</p> <p>100-V products: Approx. 80 VDC (Approx. 55 VAC) 200-V products: Approx. 110 VDC (Approx. 75 VAC) 400-V products: Approx. 180 VDC (Approx. 125 VAC)</p> <ul style="list-style-type: none"> The power supply voltage is low. 	<p>Measure the voltage between the connector (L1, L2, and L3) lines.</p> <ul style="list-style-type: none"> Increase the power supply voltage. Change the power supply. Eliminate the cause of the failure of the electromagnetic contactor on the main circuit power supply, and then turn ON the power again.
	1	Main Power Supply Undervoltage (AC interruption detected)	<ul style="list-style-type: none"> A momentary power interruption occurred. Insufficient power supply capacity: the power supply voltage dropped because there was inrush current when the main power supply was turned ON. Phase-failure: a Servo Drive with 3-phase input specifications was operated with single-phase power supply. The Servo Drive is faulty (circuit fault). 	<ul style="list-style-type: none"> Check the setting of the Momentary Hold Time (3509 hex). Set each phase of the power supply correctly. Increase the power supply capacity. Refer to <i>2-3-1 Servo Drive Model Table</i> on page 2-8 for information on the power supply capacity. Connect each phase (L1, L2, and L3) of the power supply correctly. Use L1 and L3 for single-phase 100 V and single-phase 200 V. Replace the Servo Drive.

Error No. (hex)		Name	Cause	Measures
Main	Sub			
14	0	Overcurrent	<p>The current flowing through the converter exceeded the specified value.</p> <ul style="list-style-type: none"> The Servo Drive is faulty (faulty circuit, faulty IGBT part, etc.). The Servomotor cable is short-circuited between phases U, V, and W. The Servomotor cable is ground-faulted. Motor windings are burned out. 	<ul style="list-style-type: none"> Disconnect the Servomotor cable, and turn ON the servo. If the problem immediately recurs, replace the Servo Drive with a new one. Check to see if the Servomotor cable is short-circuited between phases U, V and W by checking for loose wire strands on the connector lead. Connect the Servomotor cable correctly. Check the insulation resistance between phases U, V, and W of the Servomotor cable and the grounding wire of the Servomotor. If the insulation is faulty, replace the Servomotor. Check the balance between the resistance of each wire of the Servomotor. If resistance is unbalanced, replace the Servomotor. Check for missing connector pins in Servomotor connections U, V, and W. If any loose or missing connector pins are found, secure them firmly. Replace the Servo Drive. Do not turn the servo ON for 3 minutes after using the dynamic brake. Check model (capacity) of the Servomotor and the Servo Drive on the nameplates. Replace the Servomotor with a Servomotor that matches the Servo Drive. Wait at least 100 ms after the servo has been turned ON, then input commands. Connect an External Regeneration Resistor whose resistance is more than the minimum allowable value.
	1	IPM Error	<ul style="list-style-type: none"> The Servomotor wiring contacts are faulty. The relay for the dynamic brake has been welded due to frequent servo ON/OFF operations. The Servomotor is not suitable for the Servo Drive. The command input timing is the same as or earlier than the Servo ON timing. The resistance of the connected External Regeneration Resistor is less than the minimum allowable value. 	
15	0	Servo Drive Overheat	<p>The temperature of the Servo Drive radiator or power elements exceeded the specified value.</p> <ul style="list-style-type: none"> The ambient temperature of the Servo Drive exceeded the specified value. Overload 	<ul style="list-style-type: none"> Improve the ambient temperature and the cooling conditions of the Servo Drive. Increase the capacities of the Servo Drive and the Servomotor. Set longer acceleration and deceleration times. Reduce the load.

Error No. (hex)		Name	Cause	Measures
Main	Sub			
16	0	Overload	<p>When the feedback value for torque command exceeds the overload level specified in the Overload Detection Level Setting (3512 hex), overload protection is performed according to the overload characteristics.</p> <ul style="list-style-type: none"> The load was heavy, the effective torque exceeded the rated torque, and operation continued too long. Vibration or hunting occurred due to faulty gain adjustment. The Servomotor vibrates or makes unusual noise. The Inertia Ratio (3004 hex) setting is faulty. The Servomotor wiring is incorrect or broken. The machine was hit by an object, or the machine load suddenly became heavy. The machine was distorted. The electromagnetic brake remains ON. When multiple machines were wired, the wiring was incorrect and the Servomotor cable to was connected to a Servomotor for another axis. 	<p>Check if torque (current) waveforms oscillate or excessively oscillates vertically during analog output or communications. Check the overload warning display and the load rate through communications.</p> <ul style="list-style-type: none"> Increase the capacities of the Servo Drive and the Servomotor. Set longer acceleration and deceleration times. Reduce the load. Readjust the gain. Connect the Servomotor cable as shown in the wiring diagram. Replace the cable. Remove the distortion from the machine. Reduce the load. Measure the voltage at the brake terminals. Turn OFF the brake. Wire the Servomotor and the encoder correctly so that the wiring matches the axes.
			Refer to <i>3-2 Overload Characteristics (Electronic Thermal Function)</i> on page 3-35 for information on overload characteristics.	
18	0	Regeneration Overload	<p>The regenerative energy exceeds the processing capacity of the Regeneration Resistor.</p> <ul style="list-style-type: none"> The regenerative energy during deceleration caused by a large load inertia increased the converter voltage, and then insufficient energy absorption by the Regeneration Resistor further increased the voltage. The Servomotor rotation speed is too high to absorb the regenerative energy within the specified deceleration time. The operating limit of the external resistor is limited to a 10% duty. 	<p>Check the load rate of the Regeneration Resistor through communications. This Regeneration Resistor cannot be used for continuous regenerative braking.</p> <ul style="list-style-type: none"> Check the operation pattern (speed monitor). Check the load rate of the Regeneration Resistor and check for the excessive regeneration warning display. Increase the capacities of the Servo Drive and the Servomotor, and lengthen the deceleration time. Use an External Regeneration Resistor. Check the operation pattern (speed monitor). Check the load rate of the Regeneration Resistor and the excessive regeneration warning display. Increase the capacities of the Servo Drive and the Servomotor, and lengthen the deceleration time. Reduce the Servomotor rotation speed. Use an External Regeneration Resistor. Set the Regeneration Resistor Selection (3016 hex) to 2.
			<p>Precautions for Correct Use</p> <p>Always provide a temperature fuse or other protective measure when setting the External Regeneration Resistor Setting (3017 hex) to 2. Otherwise, the Regeneration Resistor will not be protected, generate excessive heat, and be burnt.</p>	
	1	Regeneration Tr Error	The Servo Drive regeneration drive Tr is faulty.	Replace the Servo Drive.

Error No. (hex)		Name	Cause	Measures
Main	Sub			
21	0	Encoder Communications Disconnection Error	A disconnection was detected because communications between the encoder and the Servo Drive were stopped more frequently than the specified value.	Wire the encoder correctly as shown in the wiring diagram. Correct the connector pin connections.
	1	Encoder Communications Error	There was a communications error in data from the encoder. There was a data error mainly due to noise. The encode cable is connected, but a communications data error occurred.	<ul style="list-style-type: none"> • Provide the required encoder power supply voltage 5 VDC \pm5% (4.75 to 5.25 V). Be careful especially when the encode cable is long. • If the Servomotor cable and the encoder cable are bundled together, separate them. • Connect the shield to FG.
23	0	Encoder Communications Data Error	No communications error occurred with the data from the encoder, but there is an error in the contents of the data. There was a data error mainly due to noise. The encode cable is connected, but a communications data error occurred.	<ul style="list-style-type: none"> • Provide the required encoder power supply voltage 5 VDC \pm5% (4.75 to 5.25 V). Be careful especially when the encode cable is long. • If the Servomotor cable and the encoder cable are bundled together, separate them. • Connect the shield to FG.
24	0	Error Counter Overflow	<p>Position error pulses exceeded the setting of the Following error window (6065 hex).</p> <ul style="list-style-type: none"> • Motor operation does not follow the command. <p>• The value of the Following error window (6065 hex) is small.</p>	<ul style="list-style-type: none"> • Check to see if the Servomotor rotates according to the position command pulse. Check on the torque monitor to see if the output torque is saturated. Adjust the gain. Maximize the set values on the Positive torque limit value (60E0 hex) and the Negative torque limit value (60E1 hex). Wire the encoder as shown in the wiring diagram. Lengthen the acceleration and deceleration times. Reduce the load and the speed. • Increase the set value of object 6065 hex.
	1	Excessive Speed Deviation Error	<p>The difference (speed deviation) between Motor Velocity Demand Value After Filtering and actual speed has exceeded the set value of the Excessive Speed Deviation Setting (3602 hex).</p> <p>Note When Motor Velocity Demand Value After Filtering is forced to 0 during an immediate stop due to halt or forward/reverse drive prohibition input, the speed deviation immediately increases. The speed deviation also increases when the Motor Velocity Demand Value After Filtering starts. Therefore, provide enough margin when making the settings.</p>	<ul style="list-style-type: none"> • Increase the set value of object 3602 hex. • Lengthen the acceleration time of the Motor Velocity Demand Value After Filtering. Alternatively, improve the tracking (following) performance by adjusting the gain. • Disable the Excessive Speed Deviation Setting. (3602 hex = 0)

Error No. (hex)		Name	Cause	Measures
Main	Sub			
25	0	Excessive Hybrid Deviation Error	During fully-closed control, the difference between the load position from the external encoder and the Servomotor position from the encoder was larger than the number of pulses set as the Hybrid Following Error Counter Overflow Level (3328 hex).	<ul style="list-style-type: none"> • Check the Servomotor and load connection. • Check the external encoder and Servo Drive connection. • When moving the load, check to see if the change in the Servomotor position (encoder feedback value) has the same sign as the change in the load position (external encoder feedback value). Check to see if the External Feedback Pulse Dividing Numerator and Denominator (3324 hex and 3325 hex), and External Feedback Pulse Direction Switching (3326 hex) are set correctly.
26	0	Overspeed	The Servomotor rotation speed exceeded the value set on the Overspeed Detection Level Setting (3513 hex).	<ul style="list-style-type: none"> • Do not give excessive speed commands. • Check the input frequency, dividing ratio, and multiplication ratio of the command pulse.
	1	Overspeed 2	The Servomotor rotation speed exceeded the value set for the Overspeed Detection Level Setting at Immediate Stop (3615 hex).	<ul style="list-style-type: none"> • If overshooting occurred due to faulty gain adjustment, adjust the gain. • Wire the encoder as shown in the wiring diagram.
27	1	Absolute Value Cleared ABS	The multi-rotation counter for the absolute encoder was cleared during USB communications by the CX-Drive.	<ul style="list-style-type: none"> • Check to see if the multi-rotation counter for the absolute encoder was cleared during USB communications by the CX-Drive. <p>Note This operation is performed for safety and is not an error.</p>
	4	Command Error	The position command variation after the electronic gear is higher than the specified value.	<ul style="list-style-type: none"> • Check to see if the position command variation is large. • Check the electronic gear ratio. • Check to see if the backlash compensation amount is too large.
	5	Command Generation Error	During position command processing, an error such as an “over the calculation range” error occurred.	Check to see if the electronic gear ratio, and the acceleration and deceleration rates meet the restrictions.
	6	Operation Command Duplicated	An attempt was made to establish EtherCAT communications (change from Init to Pre-Operational state) or to turn ON the servo from the controller (enable operation) while executing an FFT that operates with the Servo Drive alone or a trial run.	Check to see if EtherCAT communications is established or the servo is turned ON (enable operation) while an FFT or a trial run was being conducted.
	7	Position Data Initialized	A Config operation was performed or the multi-rotation counter was cleared for the absolute encoder during EtherCAT communications.	Check to see if Config operation was performed or the multi-rotation counter was cleared for the absolute encoder during EtherCAT communications. Note: This operation is performed for safety and is not an error.

Error No. (hex)		Name	Cause	Measures
Main	Sub			
29	1	Error Counter Overflow 1 ABS	The value that is obtained by dividing the absolute encoder position (in pulses) by the electronic gear ratio exceeded $\pm 2^{31}$ (2,147,483,648) during the initialization of position data, after the control power was turned ON in absolute value mode, after a Config operation, after FFT was executed, or after a trial run was executed.	Review the operation range of the absolute external encoder position and the electronic gear ratio.
	2	Error Counter Overflow 2	The position error in pulses exceeded $\pm 2^{29}$ (536,870,912). Alternatively, the position error in command units exceeded $\pm 2^{30}$ (1,073,741,824).	<ul style="list-style-type: none"> • Check to see if the Servomotor rotates according to the position command. • Check on the torque monitor to see if the output torque is saturated. • Adjust the gain. • Maximize the set values on the Positive torque limit value (60E0 hex) and the Negative torque limit value (60E1 hex). • Wire the encoder as shown in the wiring diagram.
30 (st)	0	Safety Input Error	At least one of the input photocouplers for safety inputs 1 and 2 turned OFF.	Check the input wiring of safety inputs 1 and 2.
33	0	Interface Input Duplicate Allocation Error 1	There is a duplicate setting in the input signal (IN1, IN2, IN3, and IN4) function allocations.	Allocate the functions to the connector pins correctly.
	1	Interface Input Duplicate Allocation Error 2	There is a duplicate setting in the input signal (IN5, IN6, IN7, and IN8) function allocations.	
	2	Interface Input Function Number Error 1	There is an undefined number specification in the input signal (IN1, IN2, IN3, and IN4) function allocations. Alternatively, a logic setting error was detected.	
	3	Interface Input Function Number Error 2	There is an undefined number specification in the input signal (IN5, IN6, IN7, and IN8) function allocations. Alternatively, a logic setting error was detected.	
	4	Interface Output Function Number Error 1	There is an undefined number specification in the output signal (OUTM1) function allocation.	
	5	Interface Output Function Number Error 2	There is an undefined number specification in the output signal (OUTM2) function allocation.	
	8	External Latch Input Allocation Error	<p>There is an error in the latch input function allocation.</p> <ul style="list-style-type: none"> • The function was allocated to input signals other than IN5, IN6, or IN7. • The function was allocated to NC. • The function was not allocated for all control modes. 	

Error No. (hex)		Name	Cause	Measures
Main	Sub			
34	0	Overrun Limit Error	The Servomotor exceeded the allowable operating range set in the Overrun Limit Setting (3514 hex) with respect to the position command input range. <ul style="list-style-type: none"> The gain is not appropriate. The set value of object 3514 hex is too small. 	<ul style="list-style-type: none"> Check the gains (the balance between position loop gain and speed loop gain) and the inertia ratio. Increase the set value of object 3514 hex. Alternatively, set object 3514 hex to 0 to disable the protection function.
36	0	Object Error	Data in the Object Save Area was corrupted when the power supply was turned ON and data was read from the EEPROM.	<ul style="list-style-type: none"> Reset all of the objects. If this error occurs repeatedly, the Servo Drive may be faulty. In this case, replace the Servo Drive. Return the Servo Drive to the dealer that it was purchased from and ask for investigation and repair.
	1			
	2			
37	0	Object Corrupted	EEPROM write verification data was corrupted when the power supply was turned ON and data was read from the EEPROM.	The Servo Drive is faulty. Replace the Servo Drive. Return the Servo Drive to the dealer that it was purchased from and ask for investigation and repair.
	1			
	2			
38	0	Drive Prohibition Input Error 1	When the Drive Prohibition Input Selection (3504 hex) was set to 0, both the Forward Drive Prohibition Input (POT) and the Reverse Drive Prohibition Input (NOT) turned ON. When object 3504 hex was set to 2, either the Forward Drive Prohibition input or the Reverse Drive Prohibition input turned ON.	Check for any problems with the switches, wires, and power supplies that are connected to the Forward Drive Prohibition input or the Reverse Drive Prohibition input. In particular, check to see if the control signal power supply (12 to 24 VDC) turned ON too slowly.
	1	Drive Prohibition Input Error 2	When object 3504 hex was set to 0, EtherCAT communications were interrupted and either POT or NOT was ON, an operation command (such as a trial run or FFT) was received from the CX-Drive. Conversely, POT or NOT turned ON while operation was being performed for a CX-Drive operation command.	
40	0	Absolute encoder system down error ABS	The voltage of the built-in capacitor dropped below the specified value because the power supply to the encoder or the battery power supply was down.	Connect the battery power supply, and then clear the absolute encoder. Unless the absolute encoder is cleared, the error cannot be reset.
41	0	Absolute Encoder Counter Overflow Error ABS	The multi-rotation counter of the encoder exceeded the specified value.	<ul style="list-style-type: none"> Set the Operation Switch When Using Absolute Encoder (3015 hex) to an appropriate value. Make sure that the traveling distance from the origin of the machine is no more than 32,767 revolutions.
42	0	Absolute Encoder Overspeed Error ABS	The Servomotor rotation speed exceeded the specified value when only the battery power supply was used during a power interruption.	<ul style="list-style-type: none"> Check the power supply voltage (5V ±5%) on the encoder side. Check the connections to connector CN2. Unless the absolute encoder is cleared, the error cannot be reset.
43	0	Encoder Initialization Error	An encoder initialization error was detected.	Replace the Servomotor.

Error No. (hex)		Name	Cause	Measures
Main	Sub			
44	0	Absolute Encoder 1-rotation Counter Error ABS	The encoder detected a 1-rotation counter error.	Replace the Servomotor.
45	0	Absolute Encoder Multi-rotation Counter Error ABS	The encoder detected a multi-rotation counter error.	Replace the Servomotor.
47	0	Absolute Encoder Status Error ABS	The rotation of the encoder was higher than the specified value when the power supply was turned ON.	Do not let the Servomotor move when the power supply is turned ON.
48	0	Encoder Phase-Z Error	A missing serial incremental encoder phase-Z pulse was detected. The encoder is faulty.	Replace the Servomotor.
49	0	Encoder CS Signal Error	A logic error was detected in the CS signal for serial incremental encoder. The encoder is faulty.	Replace the Servomotor.
50	0	External Encoder Connection Error	A disconnection was detected because communications between the external encoder and the Servo Drive were interrupted more than the specified number of times.	Wire the external encoder correctly as shown in the connection diagram. Correct the connector pin connections.
	1	External Encoder Communications Data Error	There was a communications error in data from external encoder. There was a data error mainly due to noise. The external encoder connection cable is connected, but a communications data error occurred.	<ul style="list-style-type: none"> • Provide the required external encoder power supply voltage 5 VDC \pm5% (4.75 to 5.25 V). Be careful especially when the external encoder connection cable is long. • If the Servomotor cable and the external encoder connection cable are bundled together, separate them. • Connect the shield to FG. Refer to the external encoder connection diagram.

Error No. (hex)		Name	Cause	Measures
Main	Sub			
51	0	External Encoder Status Error 0	Bit 0 of the external encoder error code (ALMC) was set to 1. Refer to the external encoder specifications.	Eliminate the cause of the error and then clear the external encoder error. Then, temporarily turn OFF the control power supply to reset.
	1	External Encoder Status Error 1	Bit 1 of the external encoder error code (ALMC) was set to 1. Refer to the external encoder specifications.	
	2	External Encoder Status Error 2	Bit 2 of the external encoder error code (ALMC) was set to 1. Refer to the external encoder specifications.	
	3	External Encoder Status Error 3	Bit 3 of the external encoder error code (ALMC) was set to 1. Refer to the external encoder specifications.	
	4	External Encoder Status Error 4	Bit 4 of the external encoder error code (ALMC) was set to 1. Refer to the external encoder specifications.	
	5	External Encoder Status Error 5	Bit 5 of the external encoder error code (ALMC) was set to 1. Refer to the external encoder specifications.	
55	0	Phase-A Connection Error	An error such as broken wiring was detected in the external encoder phase-A connection.	Check the external encoder phase A connection.
	1	Phase-B Connection Error	An error such as broken wiring was detected in the external encoder phase-B connection.	Check the external encoder phase-B connection.
	2	Phase-Z Connection Error	An error such as broken wiring was detected in the external encoder phase-Z connection.	Check the external encoder phase-Z connection.
83	–	Refer to <i>Troubleshooting Errors Related to EtherCAT Communications</i> on page 12-27.		
87	0	Immediate Stop Input Error	An Immediate Stop (STOP) signal was entered.	Check the Immediate Stop (STOP) signal wiring.
88	–	Refer to <i>Troubleshooting Errors Related to EtherCAT Communications</i> on page 12-27.		
90	–			
91	–			

Error No. (hex)		Name	Cause	Measures
Main	Sub			
92	0	Encoder Data Restoration Error	Initialization of internal position data was not processed correctly in semi-closed control mode and absolute value mode.	<ul style="list-style-type: none"> • Provide the required encoder power supply voltage 5 VDC \pm5% (4.75 to 5.25 V). Be careful especially when the encode cable is long. • If the Servomotor cable and the encoder cable are bundled together, separate them. • Connect the shield to FG.
	1	External Encoder Data Restoration Error	Initialization of internal position data was not processed correctly in fully-closed control mode and absolute value mode.	<ul style="list-style-type: none"> • Provide the required external encoder power supply voltage 5 VDC \pm5% (4.75 to 5.25 V). Be careful especially when the external encoder connection cable is long. • If the Servomotor cable and the external encoder connection cable are bundled together, separate them. • Connect the shield to FG. Refer to the external encoder connection diagram.
93	0	Object Setting Error 1	Electronic gear ratio exceeded the allowable range.	Check the object settings. The electronic gear ratio must be set between 1/1000 and 1000.
	2	Object Setting Error 2	External encoder ratio exceeded the allowable range.	Check the object settings. The external encoder ratio must be set between 1/40 and 160.
	3	External Encoder Connection Error	The set value of the External Feedback Pulse Type Selection (3323 hex) differs from the external encoder type that is actually connected for serial communications. Electronic gear ratio exceeded the allowable range.	Set object 3323 hex to conform with the external encoder type that is actually connected.

Error No. (hex)		Name	Cause	Measures
Main	Sub			
93 (continued)	4	Function Setting Error	<p>The function that was set does not support the communications cycle.</p> <ul style="list-style-type: none"> The electronic gear object ratio was not 1:1 when the communications cycle was set to 250/500 μs. Fully-closed Control Mode was selected when the communications cycle was set to 250 μs. Homing mode (hm) was set in Modes of operation (6060 hex) when the communications cycle was set to 250 or 500 μs. A mapping exceeding 20 bytes was set in an RxPDO when the communications cycle was set to 250 μs. A mapping exceeding 12 bytes was set in an RxPDO during Fully-closed Control Mode. Profile position mode (pp) or Homing mode (hm) was set in Modes of operation (6060 hex) when the communications cycle was set to 1 ms, Fully-closed Control Mode was selected, and the electronic gear object ratio was not 1:1. The number of bytes (objects) mapped to RxPDO is 0. 11 or more objects were mapped to RxPDO. 12 or more objects were mapped to TxPDO. Reference Position for CSP (4020 hex) was mapped to TxPDO when the communications cycle was set to 250/500 μs or when the electronic gear object ratio was not 1:1. 	<ul style="list-style-type: none"> Check the communications cycle settings or the electronic gear object. Check the communications cycle settings or control mode settings. Check the communications cycle settings or the mode of operation. Check the communications cycle settings or the number of bytes of mapping. Check the number of bytes of mapping or the parameters for the control mode settings. Check the number of mapped objects. Check the mapped objects.
95	0 to 4	Motor mismatch	The Servomotor does not match the Servo Drive.	Replace the Servomotor with a Servomotor that matches the Servo Drive.
99	0	Other errors	<ul style="list-style-type: none"> An error signal was detected due to excess noise or some other problem. An error was reset when safety input 1 or 2 was not in a normal state (one of the input photocouplers is not ON). 	<ul style="list-style-type: none"> Turn OFF the power once, and turn it ON again. If the error is displayed even after the power is turned ON again, the system may be faulty. Stop using the system, and replace the Servomotor and/or the Servo Drive. Return the Servo Drive to the dealer that it was purchased from and ask for investigation and repair. Reset the error when both safety input 1 and 2 are in a normal state (the both input photocouplers are ON).
Other numbers			The control circuit malfunctioned due to excess noise or some other problem. The self-diagnosis function of the Servo Drive was activated, and an error occurred in the Servo Drive.	<ul style="list-style-type: none"> Turn OFF the power once, and turn it ON again. If the error is displayed even after the power is turned ON again, the system may be faulty. Stop using the system, and replace the Servomotor and/or the Servo Drive. Return the Servo Drive to the dealer that it was purchased from and ask for investigation and repair.

● Error No. 99.0

Error No. 99.0 may occur due to the timing between safety input 1/2 and error clear input.

This error will occur if both of the following conditions are met:

- An error was cleared when at least one of the input photocouplers for safety inputs 1 and 2 was OFF (which means that a Safety Input Error (Error No. 30.0) had occurred).
- At least one of the input photocouplers for safety inputs 1 and 2 was turned from OFF to ON in a specific period during the error clear process (See below).

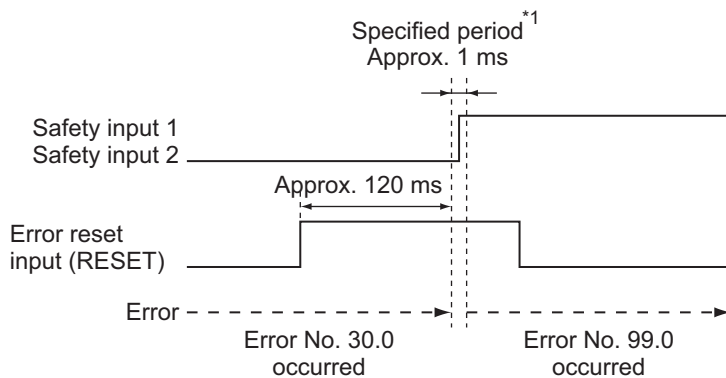

*1 Error No. 99.0 will occur if at least one of the input photocouplers for safety inputs 1 and 2 is turned from OFF to ON.



Precautions for Correct Use

Be sure to clear the error after turning ON the photocouplers for safety inputs 1 and 2 again.

Troubleshooting Errors Related to EtherCAT Communications

Error number		Name	Error timing	Cause	Measures
Main	Sub				
83	1	EtherCAT state change error	Occurs during operation.	A communications state change command was received for which the current communications state could not be changed.	Check the specifications of the communications state change command for the host controller.
	2	EtherCAT illegal state change error	Occurs during operation.	An undefined communications state change command was received.	Check the specifications of the communications state change command for the host controller.
	3	Communications synchronization error ^{*1}	Occurs during operation.	The number of consecutive errors in receiving data during the communication sync time exceeded the value specified for the Communications Error Setting (2200 hex).	<ul style="list-style-type: none"> • Connect the EtherCAT communications cable correctly. • Check to see if the EtherCAT communications cable is exposed to excessive noise. • Check that the host controller completed communications before an interruption is generated in the synchronous cycle (SYNC0 cycle).
	4	Sync Error	Occurs during operation.	Control PCB error	Replace the Servo Drive.
	5	Sync Manager WDT Error	Occurs during operation.	PDO communications were stopped for more than the specified period of time.	<ul style="list-style-type: none"> • Check the operation of the host controller. • Connect the EtherCAT communications cable correctly.
88	0	Node address setting error	Occurs when the power supply is turned ON.	The node address that was read from the rotary switches was not between 00 and 99.	<ul style="list-style-type: none"> • Turn OFF the power supply, then turn it ON again. • Replace the Servo Drive.
	1	ESC initialization error	Occurs when the power supply is turned ON.	Control PCB error	<ul style="list-style-type: none"> • Turn OFF the power supply, then turn it ON again. • Replace the Servo Drive.
	2	Interruptions Error	Occurs when the power supply is turned ON.	Control PCB error	<ul style="list-style-type: none"> • Turn OFF the power supply, then turn it ON again. • Replace the Servo Drive.
	3	SII verification error	Occurs when the power supply is turned ON.	Control PCB error	<ul style="list-style-type: none"> • Turn OFF the power supply, then turn it ON again. • Replace the Servo Drive.

^{*1} This warning can also occur when the power supply to the master is turned OFF while EtherCAT communications are established. Therefore, if you turn OFF the power supply to the master and then immediately turn OFF the power supply to the G5-series Servo Drive, an event may be saved in the error history.

Error number		Name	Error timing	Cause	Measures
Main	Sub				
90	0	Communications setting error	Occurs when the power supply is turned ON.	<ul style="list-style-type: none"> An out-of-range value was set from the host controller. A command that changes the communications state to an unsupported state was received. 	<ul style="list-style-type: none"> Make EtherCAT communications settings such as the synchronous cycle (SYNC0 cycle) correctly. Check the specifications of the communications state change command for the host controller.
91	1	Command error	Occurs during operation.	<ul style="list-style-type: none"> When bit 9 (Remote) of the Statusword (6041 hex) was set to 1 (remote), and the Servo Drive was in operation enabled state (Servo ON), a command that changes the communications state from Operational to another state (Init, Pre-Operational, Safe-Operational) was received. An unsupported number was set in Modes of operation (6060 hex). CSV or CST was set in Modes of operation (6060 hex) during fully-closed control. The Modes of operation (6060 hex) was switched in less than 2 ms. The homing operation was started when the Homing method (6098 hex) was set to a value other than 8, 12, 19, 20, 33, 34, or 35. The data setting warning (Warning No. B0 hex) occurred in a row, exceeding the Data Setting Warning Detection Setting (3781 hex) value. 	Check the command specifications of the host controller.

12-4-2 Troubleshooting with the AL Status Code

The AL Status Codes indicate errors related to EtherCAT communications.

The following list shows causes and measures of each AL status code of which the G5-series Servo Drive notifies the host controller.

AL Status Code List

AL Status Code	Name	Cause	Measures
0011 hex	Illegal State Transition Request Received	An incorrect state transition request was received.	Change the state correctly by the host controller.
0012 hex	Error State Transition Received	An unknown state transition request was received.	Change the state correctly by the host controller.
0014 hex	Slave Unit Verification Error	Data written to the SII does not match data inside the Servo Drive.	<ul style="list-style-type: none"> Write correct values to the SII, and turn OFF the power supply, then turn it ON again. Replace the Servo Drive.
0016 hex	Mailbox Setting Error	An incorrect setting was detected in the mailbox of the Sync Manager.	Review the mailbox setting in the host controller.
001B hex	Process Data WDT Error	A timeout was detected for a transmission frame of process data.	<ul style="list-style-type: none"> Wire the EtherCAT communications cable correctly. Check to see if the EtherCAT communications cable is exposed to excessive noise. Review the synchronous cycle setting in the host controller. Review the WDT setting in the host controller.
001D hex	RxPDO Setting Error	A Sync Manager RxPDO setting is incorrect.	Review the RxPDO setting in the host controller.
001E hex	TxPDO Setting Error	A Sync Manager TxPDO setting is incorrect.	Review the TxPDO setting in the host controller.
001F hex	PDO WDT Setting Error	A PDO WDT setting is incorrect.	Review the PDO WDT setting in the host controller.
0024 hex	TxPDO Mapping Error	A TxPDO mapping setting is incorrect.	Review the TxPDO mapping setting in the host controller.
0025 hex	RxPDO Mapping Error	An RxPDO mapping setting is incorrect.	Review the RxPDO mapping setting in the host controller.
002C hex	Synchronization Interruption Error	After DC Mode was confirmed, the first SYNC0 signal input was never detected.	<ul style="list-style-type: none"> Wire the EtherCAT communications cable correctly. Check to see if the EtherCAT communications cable is exposed to excessive noise. Review the synchronous cycle setting in the host controller.
0035 hex	Synchronization Cycle Setting Error	An unsupported synchronous cycle (SYNC0 cycle) was set.	Review the synchronous cycle (SYNC0 cycle) setting in the host controller.

12-4-3 Troubleshooting Using the Operation State

Symptom	Probable cause	Items to check	Measures
The 7-segment display does not light.	The control power is not supplied.	Check to see if the power supply input is within the allowed power supply voltage range.	Supply the correct power supply voltage.
		Check to see if the power supply input is wired correctly.	Wire correctly.
The ERR indicator flashes or lights.	A communications-related error occurred.	Refer to <i>Troubleshooting Errors Related to EtherCAT Communications</i> on page 12-27.	
The L/A IN and the L/A OUT indicators are OFF.	A link in the EtherCAT physical communications layer has not been established yet.	Check to see if the communications cable is connected correctly.	Connect the communications cable correctly.
		Check to see if the host controller has started.	Start the host controller.
An error occurred.	Read the error number and the error log.	Check the cause listed in <i>12-4-1 Troubleshooting with Error Displays</i> on page 12-14.	Take appropriate measures against the cause of the error that are listed in <i>12-4-1 Troubleshooting with Error Displays</i> on page 12-14.
The servo does not lock.	The power cable is not connected correctly.	Check to see if the Servomotor power cable is connected properly.	Wire the Servomotor power cable correctly.
	The Servomotor power supply is not ON.	Check the main circuit wiring and power voltage.	Input the correct power and voltage for the main circuit.
	The Forward or Reverse Drive Prohibition Input (POT or NOT) is OFF.	<ul style="list-style-type: none"> Check to see if the input for Forward or Reverse Drive Prohibition Input (POT or NOT) is OFF. Check the input of +24 VIN to CN1. 	<ul style="list-style-type: none"> Turn ON POT and NOT. Input +24 VIN to CN1.
	The torque limit is set to 0.	Check to see if the torque limits in the Positive torque limit value (60E0 hex) and the Negative torque limit value (60E1 hex) are set to 0.	Set the maximum torque to be used for each of these objects.
	The Servo Drive has broken down.	–	Replace the Servo Drive.

Symptom	Probable cause	Items to check	Measures
The servo locks but the Servomotor does not rotate.	The host controller does not give a command.	For a position command, check to see if the speed and position are set to 0.	Enter position and speed data. Start the Servomotor.
	The Servo Drive received a command but it is not accepted.	Check to see if the Servo Drive retains the object value for two communications cycles or more in Profile position mode (pp).	Set the Servo Drive so that it retains the object value for two communications cycles or more.
	It is hard to determine if the Servomotor is rotating	Check to see if the speed command given by the host controller is too small.	Check the speed command from the host controller.
	The holding brake is operating.	Check the brake interlock output (BKIR) signal and the +24 VDC power supply.	Check to see if the holding brake on a Servomotor with brake is released when the servo is locked.
	The torque limits set in the Positive torque limit value (60E0 hex) and the Negative torque limit value (60E1 hex) are too small.	Check to see if the torque limits in objects 60E0 hex and 60E1 hex are set to a value close to 0.	Set the maximum torque to be used for each of these objects.
	The Servo Drive has broken down.	–	Replace the Servo Drive.
	The Forward or Reverse Drive Prohibition Input (POT or NOT) is OFF.	Check the ON/OFF state of the POT and NOT signals from the CX-Drive.	<ul style="list-style-type: none"> • Turn ON the POT and NOT signals. • Disable them in the settings when the POT and NOT signals are not used.
	The control mode does not conform to the command.	Check the set value of the Control Mode Selection (3001 hex).	Set the control mode according to the command.
	The Servomotor power cable is wired incorrectly.	Check the wiring.	Wire correctly.
	The encoder cable is wired incorrectly.		
	Power is not supplied.	Check the power supply and the 7-segment display.	Turn ON the power.
Check the voltage between the power terminals.		Wire the power-ON circuit correctly.	
The Servo Drive has broken down.	–	Replace the Servo Drive.	
The Servomotor operates momentarily, but then it does not operate after that.	The position commands given are too little.	Check the position data and the electronic gear ratio at the host controller.	Set the correct data.
	The Servomotor power cable is wired incorrectly.	Check the wiring of the Servomotor power cable's phases U, V, and W.	Wire correctly.
	The encoder cable is wired incorrectly.	Check the encoder cable's wiring.	Wire correctly.
The Servomotor rotates without a command.	There are inputs of small values in speed control mode.	Check if there is an input in speed control mode.	Set the speed command to 0. Alternatively, change the mode to position control mode.
	The Servo Drive has broken down.	–	Replace the Servo Drive.

Symptom	Probable cause	Items to check	Measures
The Servomotor rotates in the reverse direction from the command.	The value set in the Rotation Direction Switching (3000 hex) is incorrect.	Check the set value of object 3000 hex.	Change the set value of object 3000 hex.
	The command given by the host controller is incorrect.	<ul style="list-style-type: none"> The size of the absolute command is set incorrect. The polarity of an incremental command is set incorrect. 	<ul style="list-style-type: none"> Check the actual and target values. Check the rotation direction.
The holding brake does not work.	Power is supplied to the holding brake.	Check to see if power is supplied to the holding brake.	<ul style="list-style-type: none"> Check the brake interlock output (BKIR) signal and the relay circuit. Check to see if the holding brake is worn down.
Motor rotation is unstable.	The Servomotor power cable or encoder cable is wired incorrectly.	Check the wiring of the Servomotor power cable's phases U, V, and W and check the encoder cable's wiring.	Wire correctly.
	Low rigidity is causing vibration.	Measure the vibration frequency of the load.	Enable the damping control. Set the damping filter frequency.
	The load's moment of inertia exceeds the Servo Drive's allowable value.	Calculate the load inertia.	<ul style="list-style-type: none"> Check if manual tuning can achieve proper adjustment. Increase the Servomotor capacity.
	Loose joint and/or large clearance with the machine	Check the joint with the machine.	Remove the joint looseness with the machine.
	The load and gain do not match.	Check the response waveforms for speed and torque.	Adjust the speed loop gain to stabilize the rotation.
The Servomotor is overheating.	The ambient temperature is too high.	Check to see if the ambient temperature around the Servomotor is over 40°C.	<ul style="list-style-type: none"> Lower the ambient temperature around the Servomotor to 40°C or less. (Use a fan or air conditioner.) Lower the load ratio.
	The heat radiation condition for the Servomotor is inappropriate.	<ul style="list-style-type: none"> Check to see if the specified radiation conditions are observed. For a Servomotor with a brake, check the load ratio. 	<ul style="list-style-type: none"> Improve the radiation conditions. Reduce the load. Improve ventilation.
	The Servomotor is overloaded.	Measure the torque on the analog monitor on the front panel or from the CX-Drive.	Decrease the acceleration and deceleration rates.
	The Servomotor vibrates during rotation.		Lower the speed and check the load.
The machine position is misaligned.	The coupling of the Servomotor axis and the machine is abnormal.	Check to see if the coupling of the Servomotor and the machine is misaligned.	<ul style="list-style-type: none"> Tighten the coupling again. Replace the coupling with a coupling that has no looseness.
	The host controller gave a deceleration stop command.	Check the control ladder program in the host controller.	Review the control in the host controller.

Symptom	Probable cause	Items to check	Measures
The Servomotor does not stop or is hard to stop even if the servo is turned OFF while the Servomotor is rotating.	The load inertia is too large.	<ul style="list-style-type: none"> Check the load inertia. Check the Servomotor rotation speed. The dynamic brake resistance is disconnected. 	<ul style="list-style-type: none"> Review the load inertia. Replace the Servomotor and Servo Drive with proper ones.
	The dynamic brake is disabled.	Check if the dynamic brake is disabled or broken.	<ul style="list-style-type: none"> Enable the dynamic brake, if it is disabled. Replace the brake if it is broken or if the resistor is disconnected.
The Servomotor or the load generates abnormal noise or vibration.	Vibration occurs due to improper mechanical installation.	Check to see if the Servomotor's mounting screws are loose.	Retighten the mounting screws.
		Check the load for eccentricity.	Eliminate the eccentricity. It results in torque fluctuation and noise.
		Check to see if the coupling with the load is unbalanced.	Balance the rotation.
		Check to see if the decelerator is generating any abnormal noise.	Check the decelerator specifications. Check the decelerator for malfunctions.
	Vibration occurs due to low mechanical rigidity.	Check to see if the vibration frequency is 100 Hz or lower.	If the frequency is 100 Hz or lower, set the correct damping frequency for the damping filter to eliminate the vibration.
	Vibration occurs due to machine resonance.	Check to see if the resonance frequency is high or low.	If the resonance frequency is high, set the adaptive filter to eliminate the resonance. Alternatively, measure the resonance frequency and set Notch Filter 1 and 2.
	There is a problem with the bearings.	Check for noise or vibration around the bearings.	Check to see if the bearings are mounted properly, and adjust them if necessary.
	The gain is wrong.	–	Check if manual tuning can achieve proper adjustment.
	The Speed Feedback Filter Time Constant 1 (3103 hex) is wrong.	Check the set value of object 3103 hex. Normally set 0.	Return the setting to the default value of 0. Alternatively, set a large value and operate the Servomotor.
The Torque Command Filter Time Constant 1 (3104 hex) does not match the load.	Review the set value of object 3104 hex.	Set a larger value for object 3104 hex to eliminate the vibration.	

Symptom	Probable cause	Items to check	Measures
The Servomotor or the load generates abnormal noise or vibration.	The Position Loop Gain 1 (3100 hex) is too large.	Review the setting of object 3100 hex.	Use the CX-Drive or the analog monitor to measure the response and adjust the gain.
	The Speed Loop Gain 1 (3101 hex) and the Speed Loop Integral Time Constant 1 (3102 hex) are balanced incorrectly.	Review the set values of objects 3101 hex and 3102 hex.	
	Noise is entering into the control I/O signal cable because the cable does not meet specifications.	Check to see if the cable is a twisted-pair cable or shielded twisted-pair cable with core wires that are at least 0.08 mm dia.	Use a control I/O signal cable that meets specifications.
	Noise is entering into the control I/O signal cable because the cable is longer than the specified length.	Check the length of the control I/O signal cable.	Shorten the control I/O signal cable to 3 m or less.
	Noise is entering into the cable because the encoder cable does not meet specifications.	Check to see if it is a shielded twisted-pair cable with core wires that are at least 0.12 mm dia.	Use an encoder cable that meets specifications.
	Noise is entering into the encoder cable because the cable is longer than the specified length.	Check the length of the encoder cable.	Shorten the encoder cable to less than 50 m.
	Noise is entering into the signal lines because the encoder cable is stuck or the sheath is damaged.	Check the encoder cable for damage.	Correct the encoder cable's pathway.
	Excessive noise on encoder cable.	Check to see if the encoder cable is bound together with or too close to high-current lines.	Install the encoder cable where it won't be subjected to surges.
	The FG's potential is fluctuating due to devices near the Servomotor, such as welding machines.	Check for ground problems (loss of ground or incomplete ground) at equipment such as welding machines near the Servomotor.	Ground the equipment properly and prevent current from flowing to the encoder FG.
	Errors are being caused by excessive vibration or shock on the encoder.	There are problems with mechanical vibration or Servomotor installation (such as the precision of the mounting surface, attachment, or axial offset).	Reduce the mechanical vibration or correct the Servomotor's installation.
Overshooting at startup or when stopping	The Position Loop Gain 1 (3100 hex) is too large.	Review the setting of object 3100 hex.	Adjust the gain to prevent overshooting.
	The Speed Loop Gain 1 (3101 hex) and the Speed Loop Integral Time Constant 1 (3102 hex) are balanced incorrectly.	Review the set values of objects 3101 hex and 3102 hex.	Use the CX-Drive or the analog monitor to measure the response and adjust the gain.
	The machine rigidity set by realtime autotuning is incorrect.	Review the setting of the machine rigidity.	Match the machine rigidity setting to the load rigidity.
	The set inertia ratio differs from the load.	Review the set value of the Inertial Ratio (3004 hex).	Adjust the set value of object 3004 hex with the load.

Symptom	Probable cause	Items to check	Measures
Vibration is occurring at the same frequency as the power supply.	Inductive noise is occurring.	Check to see if the drive control signal lines are too long.	Shorten the control signal lines.
		Check to see if the control signal lines and power supply lines are bound together.	<ul style="list-style-type: none"> Separate control signal lines from power supply lines. Use a low-impedance power supply for control signals.
The position is misaligned. (Position misalignment occurs without an error being output.)	There is an error in the coupling of the mechanical system and the Servomotor.	Check to see if the coupling of the mechanical system and the Servomotor is misaligned.	Correct the coupling between the mechanical system and the Servomotor.
	The gain is wrong.	–	Check if manual tuning can achieve proper adjustment.
	The load inertia is too large.	<ul style="list-style-type: none"> Check the load inertia. Check the Servomotor rotation speed. The dynamic brake resistance is disconnected. 	<ul style="list-style-type: none"> Review the load inertia. Replace the Servomotor and Servo Drive with proper ones.

12-5 Periodic Maintenance



Caution



After replacing the unit, transfer to the new unit all data needed to resume operation, before restarting the operation. Equipment damage may result.



Never repair the product by disassembling it. Electric shock or injury may result.

Servomotors and Servo Drives contain many components and will operate properly only when each of the individual components is operating properly. Some of the electrical and mechanical components require maintenance depending on application conditions. Periodic inspection and replacement are necessary to ensure proper long-term operation of Servomotors and Servo Drives. (Quoted from *The Recommendation for Periodic Maintenance of a General-purpose Inverter* published by JEMA.)

The periodic maintenance cycle depends on the installation environment and application conditions of the Servomotors and Servo Drives. Recommended maintenance times are given below for Servomotors and Servo Drives. Use these for reference in periodic maintenance.

12-5-1 Servomotor Life Expectancy

- The lifetimes for the different motor parts are listed below.

Bearings: 20,000 hours

Decelerator: 20,000 hours

Oil seal: 5,000 hours

Encoder: 30,000 hours

These values assume an ambient motor operating temperature of 40°C, a shaft load within the specified value, operation within the rated values (rated torque and rated rotation speed), and proper installation as described in this manual.

The bearings, decelerator, oil seal, and encoder can be replaced for repair.

- The radial load during Servomotor operation on timing pulleys and other components contacting belts is two or more times the static load or more. Consult with the belt and pulley manufacturers and adjust designs and system settings so that the motor allowable axial load is not exceeded even during operation. If a motor is used under a shaft load exceeding the allowable limit, the motor shaft can break and the bearings can be damaged.

12-5-2 Servo Drive Life Expectancy

- The lifetimes for the different drive parts are given below.
 Aluminum electrolytic capacitors: 28,000 hours
 (at an ambient drive operating temperature of 55°C, constant output at rated torque, constant output at rated rotation speed, and installation as described in this manual)
 Axial-flow fan: 10,000 to 30,000 hours (The limit depends on the operating conditions.)
 Inrush current prevention relay: Approx. 20,000 operations (The limit depends on the operation conditions.)
- When using the Servo Drive in continuous operation, use fans or air conditioners to maintain the ambient temperature below 40°C.
- We recommend that the ambient temperature and the power supply ON time be reduced as much as possible to lengthen the service life of the Servo Drive.
- The limit of aluminum electrolytic capacitors is greatly affected by the ambient operating temperature. Generally, an increase of 10°C in the operating ambient temperature will reduce capacitor service life by 50%.
 For example, when the ambient operating temperature is 25°C, the life expectancy will be as follows:

$$\begin{aligned} \text{Life expectancy at } 25^{\circ}\text{C} &= \text{Life expectancy at } 55^{\circ}\text{C} \times 2^{\frac{55-25}{10}} \\ &= 224,000 \text{ hours} \end{aligned}$$

- The aluminum electrolytic capacitors deteriorate even when the Servo Drive is stored with no power supplied. If the Servo Drive is not used for a long time, we recommend periodic inspection and a part replacement period of 5 years.
- If the Servomotor or Servo Drive is not to be used for a long time, or if they are to be used under conditions worse than those described above, a periodic inspection period of 5 years is recommended.
- Upon request, OMRON will inspect the Servo Drive and Servomotor and determine if part replacement is required.

12-5-3 Replacing the Absolute Encoder Battery **ABS**

Replace the Absolute Encoder Backup Battery Unit if it has been used for more than 3 years or if an Absolute Encoder System Down Error (Error No. 40.0) has occurred.

Replacement Battery Model and Specifications

Item	Specifications
Name	Absolute Encoder Backup Battery Unit
Model	R88A-BAT01G
Battery model	ER6V (Toshiba)
Battery voltage	3.6 V
Current capacity	2,000 mA · h

Mounting the Backup Battery Unit

● Mounting the Battery Unit for the First Time

Connect the Absolute Encoder Backup Battery Unit to the motor, then set up the absolute encoder. Refer to *10-2-4 Absolute Encoder Setup* on page 10-7.

After the Absolute Encoder Backup Battery Unit is attached, it is recommended that the control power supply be turned ON and OFF once a day to refresh the battery.

If you do not refresh the battery, the Battery Warning may occur due to voltage delay in the battery.

● Replacing the Battery Unit

If the Battery Warning occurs, the Absolute Encoder Backup Battery Unit must be replaced.

Replace the Battery Unit with the control power supply of the Servo Drive turned ON. If the Battery Unit is replaced with the control power supply of the Servo Drive OFF, data held in the encoder will be lost.

The Battery Warning will occur after you replace the Absolute Encoder Backup Battery Unit. Use one of the following methods to clear it.

- Perform the Error Reset (4107 hex) from the host controller.
- Use the absolute encoder setting in the CX-Drive.



Precautions for Correct Use

- If the absolute encoder is cleared using communications, all error and multi-rotation data will be lost and the absolute encoder must be set up again. Refer to *10-2-4 Absolute Encoder Setup* on page 10-7.

● **Battery Unit Mounting Method**

- 1** Prepare the replacement Battery Unit (R88A-BAT01G).

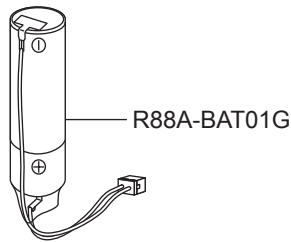

- 2** Remove the Battery Unit box cover.

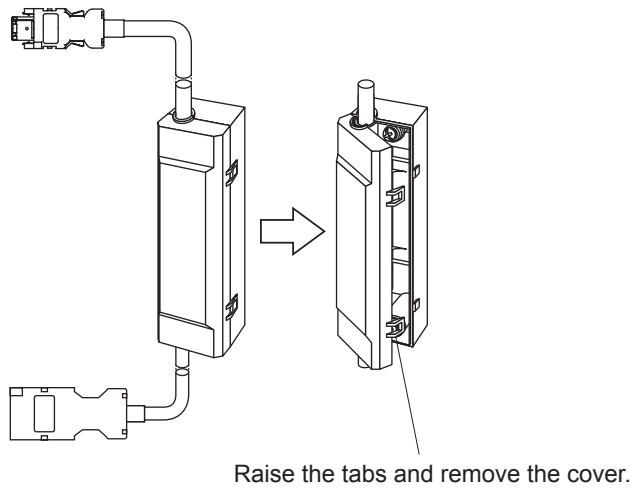

- 3** Put the Battery Unit into the battery box.

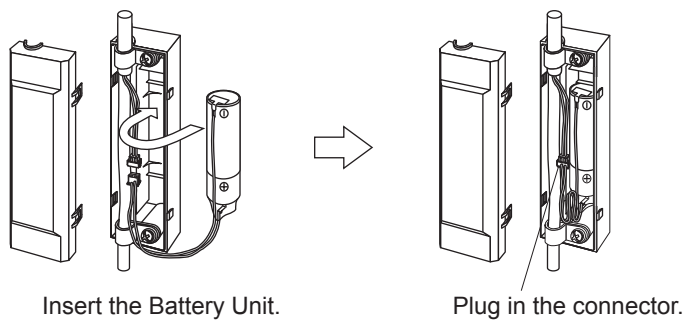

- 4** Close the cover to the battery box.

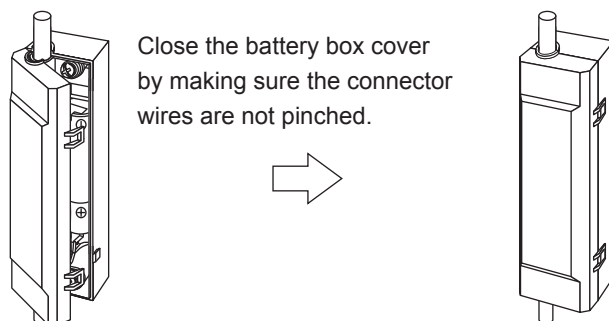



Appendices

The appendix provides explanation for the profile that is used to control the Servo Drive, lists of objects, Sysmac Error Status codes, and other information.

A-1	CiA402 Drive Profile	A-2
A-1-1	Controlling the State Machine of the Servo Drive	A-2
A-1-2	Modes of Operation	A-4
A-1-3	Communications Cycles and Corresponding Modes of Operation	A-5
A-1-4	Modes of Operation and Applied Functions	A-6
A-1-5	Changing the Mode of Operation	A-7
A-1-6	Homing Mode Specifications	A-15
A-1-7	Object Dictionary	A-22
A-1-8	Communication Objects	A-24
A-1-9	PDO Mapping Objects	A-31
A-1-10	Sync Manager Communication Objects	A-44
A-1-11	Manufacturer Specific Objects	A-49
A-1-12	Servo Drive Profile Object	A-55
A-2	Object List	A-77
A-3	Sysmac Error Status Codes	A-94
A-3-1	Error Table	A-94
A-3-2	Error Description	A-108
A-4	EtherCAT Terminology	A-168
A-5	Functional Differences among Unit Versions	A-169

A-1 CiA402 Drive Profile

This section describes the profile that is used to control the Servo Drive.

A-1-1 Controlling the State Machine of the Servo Drive

The state of G5-series Servo Drives with built-in EtherCAT communications is called "PDS state." The PDS state is controlled by the Controlword (6040 hex).

State Machine

The state of an G5-series Servo Drive changes as shown below.

Each box indicates a state, while numbers 2 to 10 and 15 indicate the state control commands.

For details on the states, refer to *State Descriptions* on page A-3 and *Command Coding* on page A-3.

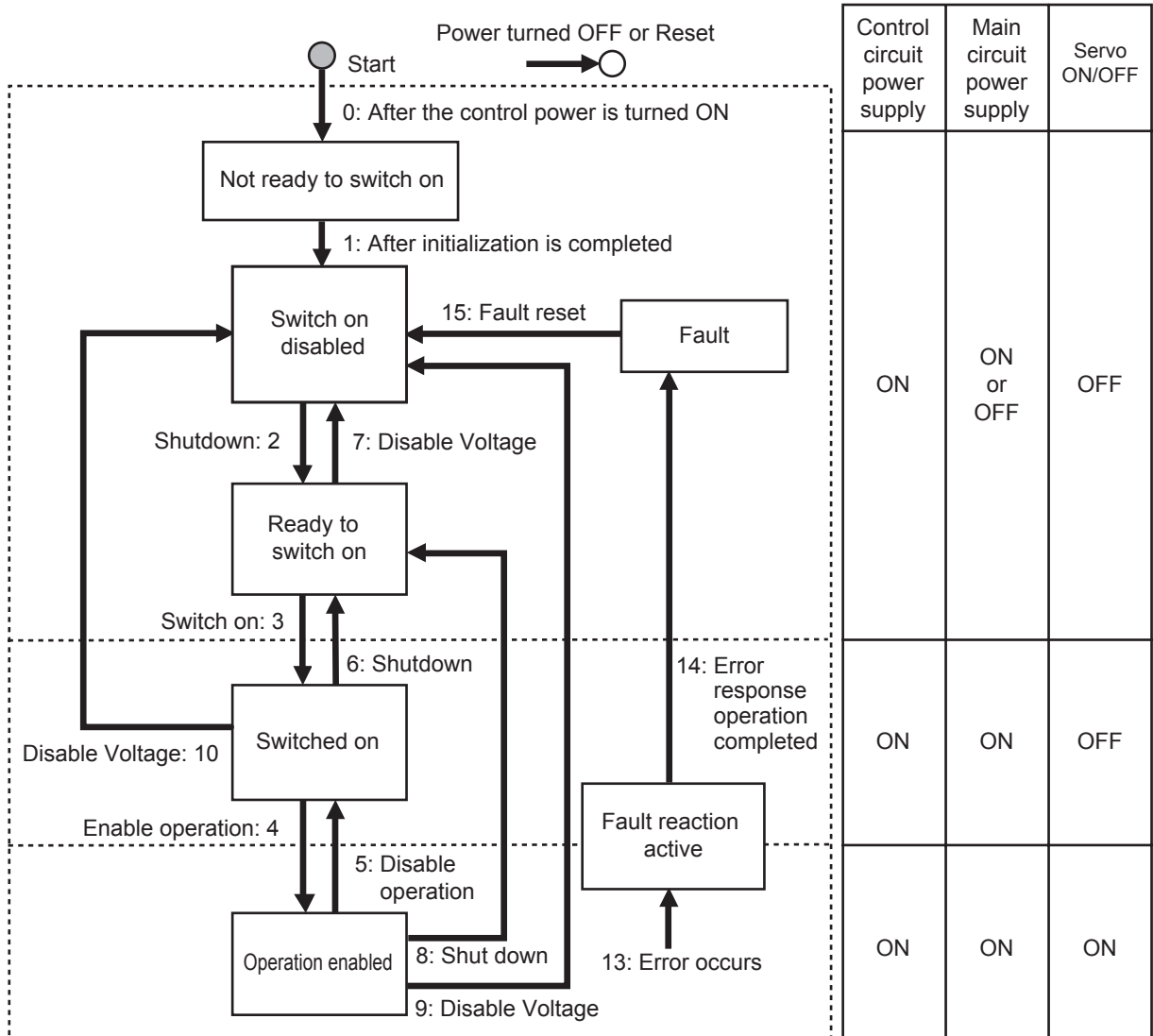

Note 1 Quick stop active state is not supported. Even if a Quick stop command is received, it will be ignored.

- 2 The operation to perform when the main circuit power is turned OFF while the Servo is ON can be set using the Undervoltage Error Selection (3508 hex).
 3508h=0: Moves to a state where the main circuit power supply is turned OFF and stops according to the setting of the Shutdown option code (605B hex).
 3508h=1: Moves to an error processing state and stops according to the setting of the Fault reaction option code (605E hex).

State Descriptions

States	Description
Not ready to switch on	The control circuit power supply is turned ON and initialization is being executed.
Switch on disabled	Initialization has been completed. Servo Drive parameters can be set.
Ready to switch on	The main circuit power supply can be turned ON. Servo Drive parameters can be set.
Switched on	The main circuit power supply is ON. Servo Drive parameters can be set.
Operation enabled	The Servo is ON. Servo Drive parameters can be set.
Fault reaction active	There was an error in the Servo Drive and the cause is being determined. Servo Drive parameters can be set.
Fault	There is an error in the Servo Drive. Servo Drive parameters can be set.

Command Coding

State is controlled by combining the bits in the Controlword (6040 hex) as shown in the following table.
 fr = fault reset, eo = enable operation, qs = quick stop, ev = enable voltage, so = switch on

Command	Controlword Bit					Move to
	Bit 7 fr	Bit 3 eo	Bit 2 qs	Bit 1 ev	Bit 0 so	
Shutdown	×	×	1	1	0	2, 6, 8
Switch on	×	0	1	1	1	3
Switch on + enable operation	×	1	1	1	1	3 + 4 ^{*1}
Disable voltage	×	×	×	0	×	7, 9, 10
Quick stop	×	×	0	1	×	Not supported ^{*2}
Disable operation	×	0	1	1	1	5
Enable operation	×	1	1	1	1	4
Fault reset	0 → 1 ^{*3*4}	×	×	×	×	15

- *1 The state automatically moves to Operation enabled state after Switched on state.
- *2 Quick stop commands are not supported. Even if a quick stop command is received, it will be ignored.
- *3 Bit 7: Operation when Fault reset bit turns ON.
 Fault state: Errors are reset and the Servo Drive returns to its initialized state.
 If there are any warnings (Warning (6041 hex: Statusword bit 7), they are reset.
 State other than Fault state: If there are any warnings (Warning (6041 hex: Statusword bit 7), they are reset.
 The state will change according to command bits 0 to 3.
- *4 When an error reset is executed with bit 7, set the bit back to 0 before giving the next command.

State Coding

State is indicated by the combination of bits in Statusword (6041 hex), as shown in the following table.

State	Bit 6 sod ^{*1}	Bit 5 qs ^{*2}	Bit 4 ve ^{*3}	Bit 3 f ^{*4}	Bit 2 oe ^{*5}	Bit 1 so ^{*6}	Bit 0 rtso ^{*7}
Not ready to switch on	0	0	×	0	0	0	0
Switch on disabled	1	1	×	0	0	0	0
Ready to switch on	0	1	×	0	0	0	1
Switched on	0	1	×	0	0	1	1
Operation enabled	0	1	×	0	1	1	1
Fault reaction active	0	1	×	1	1	1	1
Fault	0	1	×	1	0	0	0

- *1 sod = switch on disabled
- *2 qs = quick stop
- *3 ve = voltage enabled
- *4 f = fault
- *5 oe = operation enabled
- *6 so = switched on
- *7 rtso = ready to switch on

A-1-2 Modes of Operation

G5-series Servo Drives with built-in EtherCAT communications support the following Modes of operation.

- csp: Cyclic synchronous position mode
- csv: Cyclic synchronous velocity mode
- cst: Cyclic synchronous torque mode
- pp: Profile position mode
- hm: Homing mode

The operation mode is set in Modes of operation (6060 hex). It is also given in Modes of operation display (6061 hex).

The operation modes supported by the Servo Drive can be checked in Supported drive modes (6502 hex).

If an unsupported operation mode is specified, a Function Setting Error (Error No. 93.4) will occur.



Precautions for Correct Use

- Cyclic synchronous velocity mode, Cyclic synchronous torque mode, and Homing mode are supported for unit version 2.0 or later.
- Profile position mode (pp) is supported for unit version 2.1 or later.

A-1-3 Communications Cycles and Corresponding Modes of Operation

This section describes the Modes of operation that can be used for each combination of communications cycle and PDO mapping set in the RxPDO.

When the RxPDO is set to 1600 hex, the combination of the communications cycle and the available Modes of operation varies depending on the total size of mapped objects. In the table below, the total size of mapped objects is shown in parentheses. For details on the RxPDO (1600 hex), refer to 5-4-4 Variable PDO Mapping.

- Semi-closed Control

Any of 1701 to 1705 hex or 1600 hex can be set in the RxPDO when 0 to 5 (semi-closed control) is set for the Control Mode Selection (3001 hex). The following table shows the Modes of operation that can be used for each combination of communications cycle and RxPDO.

Communications cycle (μs) ^{*1}	RxPDO		
	When electronic gear ratio is 1:1		When electronic gear ratio is not 1:1
	1701, 1702, 1703, 1705, 1600 hex (20 bytes or less)	1704, 1600 hex (20 to 24 bytes) ^{*3}	1701, 1702, 1703, 1704, 1705, 1600 hex (24 bytes or less) ^{*3}
250	csp, csv, cst	_ ^{*2}	_ ^{*2}
500	csp, csv, cst	csp, csv, cst	_ ^{*2}
1000	csp, csv, cst, pp, hm	csp, csv, cst, pp, hm	csp, csv, cst, pp, hm
2000	csp, csv, cst, pp, hm	csp, csv, cst, pp, hm	csp, csv, cst, pp, hm
4000	csp, csv, cst, pp, hm	csp, csv, cst, pp, hm	csp, csv, cst, pp, hm

*1 The communications cycle is set in the controller. Refer to the manual of the controller that is connected for the setting procedure.

*2 The Function Setting Error (Error No. 93.4) will occur if a setting labeled “– (Not supported)” is set.

*3 If the total size of mapped objects exceeds 24 bytes, a Function Setting Error (Error No. 93.4) will occur.

Note For unit version 2.0, the electronic gear ratio can be set only to 1:1. A Function Setting Error (Error No. 93.4) does not occur even when a value other than 1:1 is set.

Profile position mode (pp) and an object 1600 hex are supported for unit version 2.1 or later.

- Fully-closed Control

Only 1701 hex can be set in the RxPDO when 6 (fully-closed control) is set for the Control Mode Selection (3001 hex). The following table shows the Modes of operation that can be used for each combination of communications cycle and RxPDO.

Communications cycle (μs) ^{*1}	RxPDO ^{*3}			
	When electronic gear ratio is 1:1		When electronic gear ratio is not 1:1	
	1701, 1600 hex (12 bytes or less)	1702, 1705, 1600 hex (13 to 24 bytes)	1701, 1600 hex (12 bytes or less)	1702, 1705, 1600 hex (13 to 24 bytes) ^{*3}
250	_ ^{*2}	_ ^{*2}	_ ^{*2}	_ ^{*2}
500	csp	_ ^{*2}	_ ^{*2}	_ ^{*2}
1000	csp, pp, hm	_ ^{*2}	csp	_ ^{*2}
2000	csp, pp, hm	_ ^{*2}	csp, pp, hm	_ ^{*2}
4000	csp, pp, hm	_ ^{*2}	csp, pp, hm	_ ^{*2}

*1 The communications cycle is set in the controller. Refer to the manual of the controller that is connected for the setting procedure.

*2 The Function Setting Error (Error No. 93.4) will occur if a setting labeled “– (Not supported)” is set.

*3 If the total size of mapped objects exceeds 24 bytes, a Function Setting Error (Error No. 93.4) will occur.

Note For unit version 2.0, the electronic gear ratio can be set only to 1:1. A Function Setting Error (Error No. 93.4) does not occur even when a value other than 1:1 is set.
 Profile position mode (pp) and an object 1600 hex are supported for unit version 2.1 or later.



Additional Information

For functional differences between unit versions, refer to *A-5 Functional Differences among Unit Versions* on page A-169.

A-1-4 Modes of Operation and Applied Functions

The relationships between the modes of operation of G5-series Servo Drives with built-in EtherCAT communications and the application functions are shown below.

○: Supported, –: Not supported

Function	Mode of operation				Supported specifications ^{*2*3}		
	csp pp ^{*10} hm	csv	cst	Fully-closed ^{*1}			
Notch filter (notch 1 to notch 4) ^{*4}	○	○	○	○	4		
Damping filter	○	–	–	○	2		
Speed feed-forward	○	–	–	○	○		
Torque feed-forward function ^{*5}	○	○	–	○	–	○	○
Position command FIR filter ^{*6}	○	–	–	○	–		
Position command smoothing filter	○	–	–	○	○	○	○
Realtime Autotuning (RTAT) ^{*7}	○	○	○	○	○	–	–
Instantaneous speed observer ^{*8}	○	○	–	–	–	○	–
Disturbance Observer ^{*9}	○	○	–	–	–	–	○
					*5	*8	*9

- *1 The fully-closed modes of operation are csp, pp and hm.
- *2 ○ in the Supported specifications column depends on the applicable range of the related control mode.
- *3 The PDO mapping conditions depend on Rx and Tx (number of bytes of the PDOs) values given above in the control mode correspondence table.
- *4 When one adaptive filter is enabled, notch 3 is set automatically. When two adaptive filters are enabled, notch 3 and notch 4 are set automatically.
- *5 When RTAT is enabled, you cannot use the torque feed-forward function. (They are in an exclusive relationship.)
- *6 The FIR filter is enabled only in hm, pp and csp mode when the communications cycle is set to 1 ms or above.
- *7 When Realtime Autotuning (RTAT) is enabled, the instantaneous speed observer and disturbance observer are automatically disabled. RTAT must be disabled to enable the instantaneous speed observer.
- *8 When the instantaneous speed observer is enabled, the disturbance observer is automatically disabled.
- *9 RTAT and the instantaneous speed observer must be disabled to enable the disturbance observer.
- *10 Profile position mode (pp) is supported for unit version 2.1 or later.

A-1-5 Changing the Mode of Operation

The operation mode of the G5-series Servo Drives with built-in EtherCAT communications is changed as described below.

● Changing the Mode of Operation

By setting a mode of operation from the controller, the Servomotor can be operated while switching the control mode of the Servo Drive.

The mode of operation is changed by changing the set value of Modes of operation (6060 hex).

When changing the mode of operation, also change the command value of the object mapped to the RxPDO. For example, in the Cyclic synchronous position mode (csp), which is a position control mode, the Target position (607A hex) is enabled as the command value, whereas in the Cyclic synchronous velocity mode (csv), which is a speed control mode, the Target velocity (60FF hex) is enabled as the command value. Therefore, when the mode of operation is changed from the position control mode to the speed control mode, the enabled command value is set to the Target velocity (60FF hex) at the same time.

The actual mode of operation of the Servo Drive can be checked from the Modes of operation display (6061 hex).

Note 1 Change the operation mode while the Servomotor is stopped.

If you change the operation mode while the Servomotor is running, shock may occur in the operation of the Servomotor.

- 2 Wait at least 2 ms before changing the mode of operation again. If you change the mode of operation again within 2 ms, a Command Error (Error No. 91.1) will occur.

● Changing to an Unsupported Control Mode

- If 6060 hex is set to a value other than 0 (nma), 1 (pp), 6 (hm), 8 (csp), 9 (csv), or 10 (cst), a Command Error (Error No. 91.1) will occur.
- If 6060 hex is set to 9 (csv) or 10 (cst) during fully-closed control mode, a Command Error (Error No. 91.1) will occur.
- If 6060 hex is set to 6 (hm) when the communications cycle is set to 250 or 500 μ s, a Function Setting Error (Error No. 93.4) will occur.

Note Profile position mode (pp) is supported for unit version 2.1 or later. If pp is specified for unit version 2.0, a Command Error (Error No. 91.1) will occur.

● Changing the Control Mode under Warning Conditions

The operation when there is a warning for the related data (Data setting warning or Command warning) is different depending on the control mode.

- Changing to csp, csv, or cst
If there is a warning for the related data, you cannot change to csp, csv, or cst. The current operation mode is maintained.
- Changing to hm and pp
The operation mode changes even when there is a warning for the related data. For the hm mode, a homing error occurs instead of a warning.

Note Profile position mode (pp) is supported for unit version 2.1 or later. If pp is specified for unit version 2.0, operating mode will not change to Profile position mode (pp).

● **Changing the Control Mode to pp or hm Mode When the Motor Is Running**

- When the Halt bit is OFF, the Servomotor comes to an immediate stop if the rising edge of 6040 hex bit 4 (start bit) is not detected when the control mode is changed to pp or hm mode while the motor is running.
- When the Halt bit is ON, the Servomotor performs the stop operation according to the setting of the Halt option code (605D hex) if the rising edge of 6040 hex bit 4 (start bit) is not detected when the control mode is changed to pp or hm mode while the motor is running.

Note Profile position mode (pp) is supported for unit version 2.1 or later.

● **Precautions in hm Mode**

- To disable the stop process using drive prohibition when the control mode changes to hm mode during Servomotor operation, the Servomotor is momentarily set to an immediate stop regardless of the detection of the rising edge of 6040 hex bit 4 (start bit). However, when the Halt bit is ON, the Servomotor stops according to the setting of 605D hex.
- When you change to another operation mode while the motor is running in hm mode (during homing operation), the operation continues for approx. 2 ms, and the stop operation for drive prohibition is not executed. Therefore, change the control mode when the Servomotor has stopped after homing is attained.

● **Modes of Operation Display**

The actual mode of operation can be checked from the Modes of operation display (6061 hex). The display is as follows depending on the state of the Servo Drive:

Servo Drive status		Modes of Operation Display (6061 hex)
Servo OFF (not operation enabled state)		0: Not specified
Servo ON (operation enabled state)		The value that is shown depends on the setting of Modes of operation (6060 hex).
Not following commands in the Controlword (6060 hex) when the servo is ON	Drive prohibition ^{*1}	The value that is shown depends on the setting of Modes of operation (6060 hex). (The stop process is executed inside the Servo Drive using a deceleration stop command generated within the Servo Drive.)
	Deceleration stop in progress due to main circuit power OFF	
	Deceleration stop in progress due to Servo OFF	
Deceleration stop in progress due to an error		0: Not specified (Fault reaction active state or Fault state during an error)

*1 When Drive Prohibition Input Selection (3504 hex) = 0.

*2 When Undervoltage Error Selection (3508 hex) = 0.

● **Bit Displays According to Modes of Operation Display (6061 Hex)**

Some of the bits in the Statusword (6041 hex) and Statusword 1 (4000 hex) are dependent on the control mode. Their relationship with Modes of operation display is shown in the following table:

Object	Bit	6061: Modes of Operation Display					
		Position control mode				Speed Control Mode	Torque Control Mode
		csp	pp ^{*4}	hm	Not specified	csv	cst
6041 hex	10	0	Target reached	Target reached	0	0	0
	12	Target position ignored ^{*1}	Acknowledge	Home attained ^{*3}	0	Target velocity ignored ^{*1}	Target torque ignored ^{*1}
	13	Following error	Following error	Homing error ^{*3}	0	0	0
4000 hex	1	DEN	DEN	DEN	1	0	0
	4	0	0	0	0	0	VLIM ^{*2}
	7	0	0	0	0	VCMP ^{*2}	0
	8	NEAR	NEAR	NEAR	1	0	0

- *1 When commands in the Controlword (6040 hex) are not followed when the servo is ON, this bit will be 0 (ignored). For details, see figures 1) to 3) below.
- *2 When commands in the Controlword (6040 hex) are not followed when the servo is ON, this bit will be 0. For details, see figures 2) and 3) below.
- *3 When commands in the Controlword (6040 hex) are not followed when the servo is ON, the preceding value is retained. For details, see figure 4) below.
- *4 Profile position mode (pp) is supported for unit version 2.1 or later.

1) Example of Servo OFF during Operation in csp

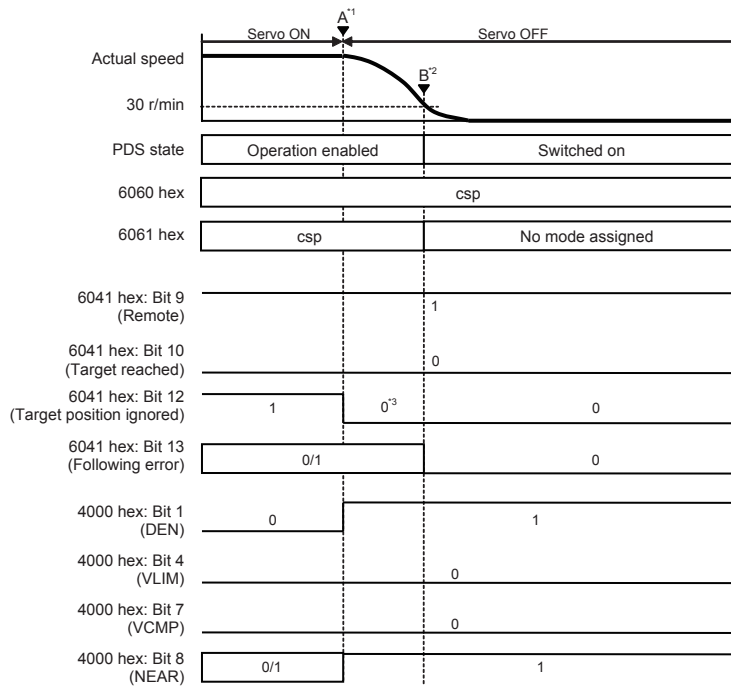

*1 When the servo is turned OFF, a deceleration stop starts and 6061 hex continues to show the same mode as the mode of operation (csp) specified in 6060 hex.

*2 After the motor stops, No mode assigned is shown by 6061 hex.

*3 Bit 12 will be 0 during a deceleration due to servo OFF.

Note The operation during the interval from A to B for drive prohibition and main circuit power OFF is the same as when the servo is turned OFF.

2) Example of Servo OFF during Operation in csv

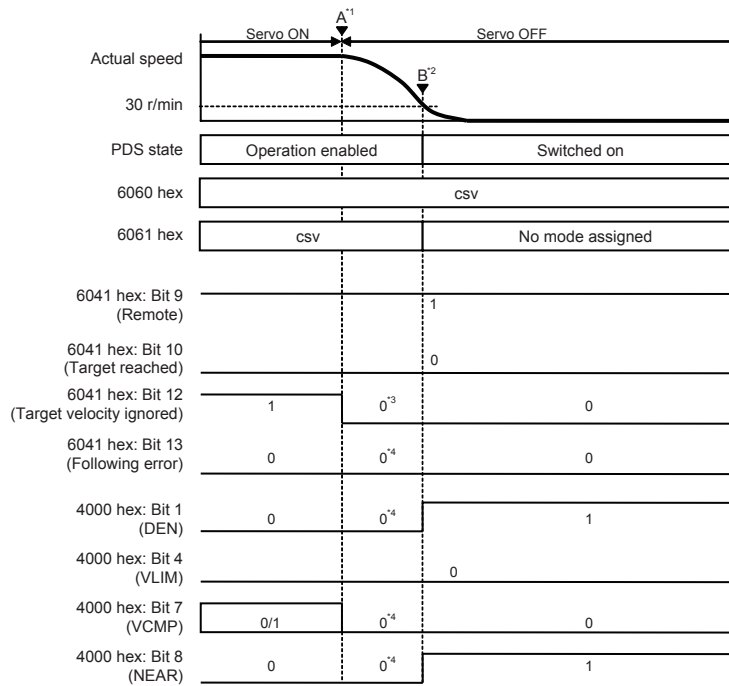

- *1 When the servo is turned OFF, a deceleration stop starts and 6061 hex continues to show the same mode as the mode of operation (csv) specified in 6060 hex.
- *2 After the motor stops, No mode assigned is shown by 6061 hex.
- *3 Bit 12 will be 0 during a deceleration due to servo OFF.
- *4 The mode shown in 6061 hex is forced to 0 because the mode shown in 6061 hex is different from the mode of operation.

Note The operation during the interval from A to B for drive prohibition and main circuit power OFF is the same as when the servo is turned OFF.

3) Example of Servo OFF during Operation in cst

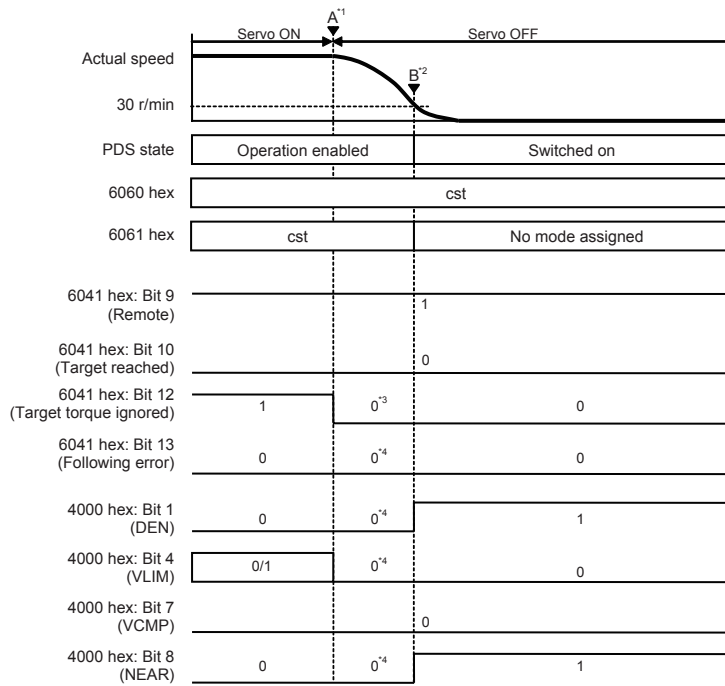

- *1 When the servo is turned OFF, a deceleration stop starts and 6061 hex continues to show the same mode as the mode of operation (cst) specified in 6060 hex.
- *2 After the motor stops, No mode assigned is shown by 6061 hex.
- *3 Bit 12 will be 0 during a deceleration due to servo OFF.
- *4 The mode shown in 6061 hex is forced to 0 because the mode shown in 6061 hex is different from the mode of operation.

Note The operation during the interval from A to B for drive prohibition and main circuit power OFF is the same as when the servo is turned OFF.

4) Example of Servo OFF during Operation in hm

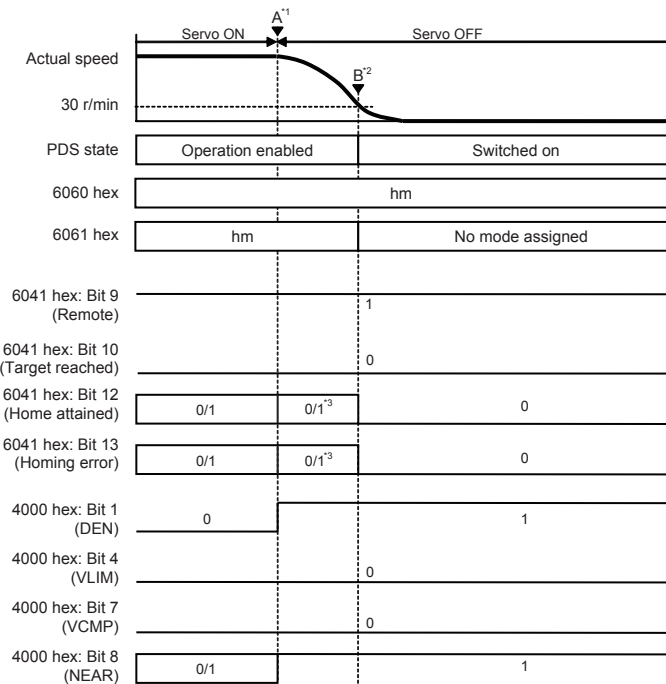

- *1 When the servo is turned OFF, a deceleration stop starts and 6061 hex continues to show the same mode as the mode of operation (hm) specified in 6060 hex.
- *2 After the motor stops, No mode assigned is shown by 6061 hex.
- *3 Bits 12 and 13 will retain the preceding values during deceleration when the servo is turned OFF.

Note The operation during the interval from A to B for main circuit power OFF is the same as when the servo is turned OFF. The stop function due to drive prohibition is disabled during the homing operation in hm mode.

5) Example of Servo OFF during Operation in pp (Unit version 2.1 or later)

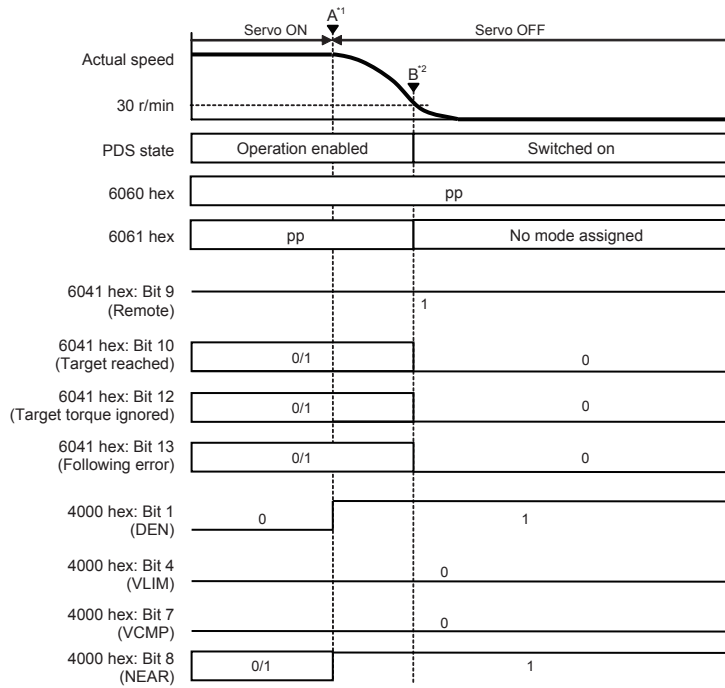

*1 When the servo is turned OFF, a deceleration stop starts and 6061 hex continues to show the same mode as the mode of operation (pp) specified in 6060 hex.

*2 After the motor stops, No mode assigned is shown by 6061 hex.

Note The operation during the interval from A to B for drive prohibition and main circuit power OFF is the same as when the servo is turned OFF.

A-1-6 Homing Mode Specifications

This section describes the Homing mode of the G5-series Servo Drives with built-in EtherCAT communications.

Homing Mode Configuration

The configuration of the Homing mode is as follows:

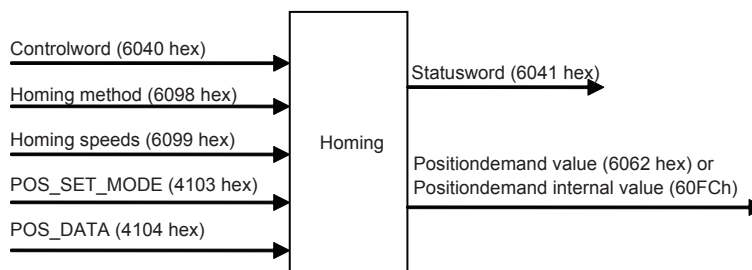

Supported Homing Methods

The following homing methods are supported by G5-series Servo Drives with built-in EtherCAT communications:

Homing method	Explanation	Reference page
0	Not specified	-
8	Homing by Origin Proximity Input and origin signal (forward operation start)	page A-18
12	Homing by Origin Proximity Input and origin signal (reverse operation start)	page A-18
19	Homing without origin signal (forward operation start)	page A-19
20	Homing without origin signal (reverse operation start)	page A-19
33	Homing with origin signal (reverse operation start)	page A-20
34	Homing with origin signal (forward operation start)	page A-20
35	Present home preset	page A-20

The homing methods supported by the Servo Drive can be checked in Supported homing method (60E3 hex).

Related Objects

Index	Sub-index	Object name	Access	Size	Unit	Setting range	Default setting
6040 hex	00 hex	Controlword	RW	U16	0 to FFFF hex	–	0000 hex
6060 hex	00 hex	Modes of operation	RW	INT8	–	0 to 10	0000 hex
6098 hex	00 hex	Homing method	RW	INT8	–	–128 to 127	0
6099 hex	01 hex	Speed during search for switch	RW	U32	Command units/s	100 to 3,276,700	5,000
6099 hex	02 hex	Speed during search for zero	RW	U32	Command units/s	100 to 3,276,700	5,000
4103 hex	00 hex	Coordinate System Setting Mode	RW	U16	–	0000 to FFFF hex	0
4104 hex	00 hex	Coordinate System Setting Position	RW	INT32	Command units	–2,147,483,648 to 2,147,483,647	0
6041 hex	00 hex	Statusword	RO	U16	0 to FFFF hex	–	0000 hex
6083 hex	00 hex	Profile acceleration	RW	U32	Command units/s ²	1 to 655,350,000	1,000,000
6084 hex	00 hex	Profile deceleration	RW	U32	Command units/s ²	1 to 655,350,000	1,000,000
6086 hex	00 hex	Motion profile type	RW	INT16	–	–1 to 0	0

Controlword (6040 hex) in Homing Mode

Bit	Name	Code	Description
4	Homing operation start	0	Do not start homing procedure.
		1	Start or continue homing procedure.
8	Halt	0	Enable bit 4
		1	Stop axis according to halt option code (605D hex)

Bit 6 is not used.

For details on other bits, refer to *Controlword (6040 hex)*.

Statusword (6041 hex) in Homing Mode

Bit	Name	Explanation
10	Target reached	The status of the homing operation is indicated by the combination of these bits.
12	Homing attained	
13	Homing error	The status based on the combination of the bits are shown in the following table.

Bit 13	Bit 12	Bit 10	Explanation
0	0	0	Homing procedure is in progress.
0	0	1	Homing procedure is interrupted or not started.
0	1	0	Homing is attained, but target is not reached.
0	1	1	Homing procedure is completed successfully.
1	0	0	Homing error occurred, velocity is not 0.
1	0	1	Homing error occurred, velocity is 0.
1	1	0	Reserved
1	1	1	Reserved

Homing Operation

This section describes the operation of the supported homing methods.

● Homing Methods 8 and 12: Homing by Origin Proximity Input and Origin Signal

These Homing methods use the Origin Proximity Input that is enabled only in some parts of the drive range, and stops when an origin signal is detected.

An origin signal is detected in the forward direction for Homing method 8 and in the reverse direction for Homing method 12.

The operation start direction of the homing operation is the same as the direction of detection of the origin signal when the Origin Proximity Input is OFF, and the reverse direction when the Origin Proximity Input is ON.

The operation direction reverses for the forward drive prohibition input.

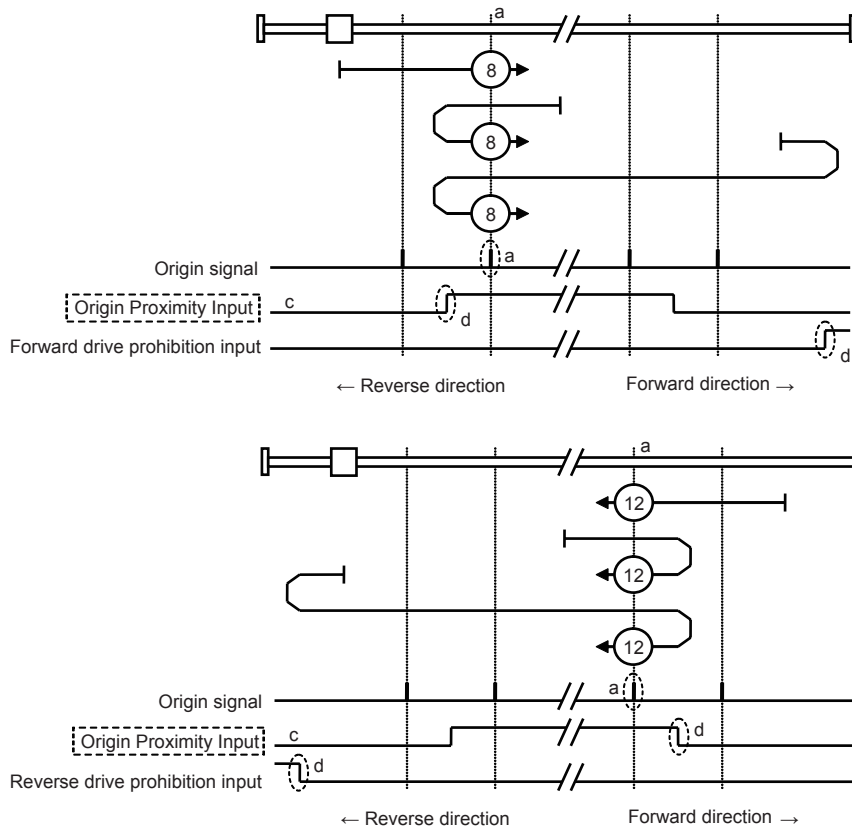

A homing error occurs in the following cases.

- When the drive prohibition inputs on both sides are ON at the same time.
- When the drive prohibition input of one side is ON, and the drive prohibition input of the other side is turned ON without detecting the rising edge of the Origin Proximity Input.
- When the homing operation is started with a sensor without an origin signal (Z phase), such as an absolute scale, during fully-closed control.

- Note 1** If an origin signal exists near the point where the Origin Proximity Input turns ON or OFF, the first origin signal after the Origin Proximity Input is turned ON or OFF may not be detected. Set the Origin Proximity Input so that the origin signal occurs away from the point where the Origin Proximity Input turns ON or OFF.
- 2 During the homing operation, the stop function for the Stop Selection for Drive Prohibition Input is disabled.
 - 3 When the Drive Prohibition Input Selection (3504 hex) is set to 0, a Drive Prohibition Input Error 1 (Error No. 38.0) will occur if the drive prohibition input is detected on both sides.
 - 4 When the Drive Prohibition Input Selection (3504 hex) is set to 1, a homing error (Home error = 1) will occur when the drive prohibition input is detected on both sides. If this Homing method is used without using the drive prohibition input, do not assign the drive prohibition input to a general-purpose input. For details on assigning the general-purpose input signals, refer to 7-1 *Sequence I/O Signals* on page 7-2.
 - 5 When the Drive Prohibition Input Selection (3504 hex) is set to 2, a Drive Prohibition Input Error 1 (Error No. 38.0) will occur if the drive prohibition input is detected on one side. When using this Homing method, set the Drive Prohibition Input Selection (3504 hex) to a value other than 2.

● **Homing Methods 19 and 20: Homing without an Origin Signal**

In these homing methods, only the Origin Proximity Input is used. Homing method 19 stops when the Origin Proximity Input turns OFF, and Homing method 20 stops when the Origin Proximity Input turns ON. The operation start direction of the homing operation is the forward direction for an OFF Origin Proximity Input, and the reverse direction for an ON Origin Proximity Input.

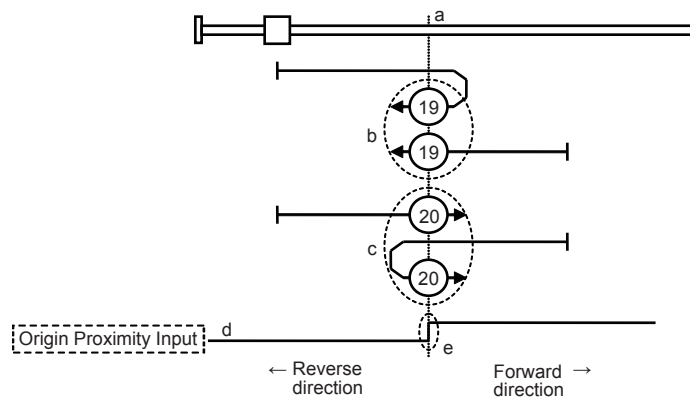

A homing error occurs in the following cases.

- When the drive prohibition inputs on both sides are ON at the same time.
- When an ON or OFF Origin Proximity Input is not detected before the drive prohibition input in the drive direction turns ON.

- Note 1** During the homing operation, the stop function for the Stop Selection for Drive Prohibition Input is disabled.
- 2 When the Drive Prohibition Input Selection (3504 hex) is set to 0, a Drive Prohibition Input Error 1 (Error No. 38.0) will occur if the drive prohibition input is detected on both sides.
 - 3 When the Drive Prohibition Input Selection (3504 hex) is set to 1, a homing error (Home error = 1) will occur when the drive prohibition input is detected on both sides. If this Homing method is used without using the drive prohibition input, do not assign the drive prohibition input to a general-purpose input. For details on assigning the general-purpose input signals, refer to 7-1 *Sequence I/O Signals* on page 7-2.
 - 4 When the Drive Prohibition Input Selection (3504 hex) is set to 2, a Drive Prohibition Input Error 1 (Error No. 38.0) will occur if the drive prohibition input is detected on one side. When using this Homing method, set the Drive Prohibition Input Selection (3504 hex) to a value other than 2.

● Homing Methods 33 and 34: Homing with an Origin Signal

In these Homing methods, only the origin signal is used.

The operation start direction of the homing operation is the reverse direction in Homing method 33 and the forward direction in Homing method 34.

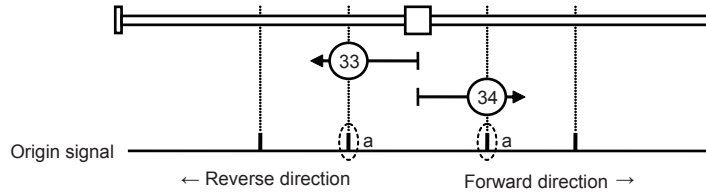

A homing error occurs in the following cases.

- When the drive prohibition inputs on both sides are ON at the same time.
- If no origin signal is detected before the drive prohibition input of the drive direction turns ON.
- When the homing operation is started with a sensor without an origin signal (Z phase), such as an absolute scale, during fully-closed control.

- Note 1** During the homing operation, the stop function for the Stop Selection for Drive Prohibition Input is disabled.
- 2 When the Drive Prohibition Input Selection (3504 hex) is set to 0, a Drive Prohibition Input Error 1 (Error No. 38.0) will occur if the drive prohibition input is detected on both sides.
 - 3 When the Drive Prohibition Input Selection (3504 hex) is set to 1, a homing error (Home error = 1) will occur when the drive prohibition input is detected on both sides.
If this Homing method is used without using the drive prohibition input, do not assign the drive prohibition input to a general-purpose input.
For details on assigning the general-purpose input signals, refer to 7-1 *Sequence I/O Signals* on page 7-2.
 - 4 When the Drive Prohibition Input Selection (3504 hex) is set to 2, a Drive Prohibition Input Error 1 (Error No. 38.0) will occur if the drive prohibition input is detected on one side.
When using this Homing method, set the Drive Prohibition Input Selection (3504 hex) to a value other than 2.

● Homing Method 35: Present Home Presetting

In this Homing method, the present position is considered as the origin.

Set the mode in Coordinate System Setting Mode (4103 hex). By using the Coordinate System Setting Position (4104 hex), you can specify the value of the present position.

You can use this method even when you are using an absolute encoder, but the position is not saved in the Home offset (607C hex). When the control power is turned OFF or when Config (4100 hex) is executed, the origin set by this Homing method is disabled.

This Homing method can be executed only when the mode of operation is set to Homing mode (hm) and the servo is ON. If this Homing method is executed during the latch operation, the latch operation is disabled.

A homing error occurs in the following cases.

- During the Cyclic synchronous velocity mode (csv) or Cyclic synchronous torque mode (cst)
- When backlash compensation is not completed.

Coordinate System Setting Mode (4103 hex)

Index	Sub	Name	R/W	Data type	Unit	Min	Max	Default
4103 hex	00 hex	POS_SET_MODE (Coordinate System Setting Mode)	rw	U16	–	See following table.		83 hex

Bit	15	...	8	7	6	5	4	3	...	0
	Reserved("0")			REFE	0	0	0	POS_SEL		

[POS_SEL]

3: Set the value of the Coordinate System Setting Position (4104 hex) to the Position Demand Value (6062 hex) and Position Demand Value After Filtering (4018 hex).

For the Position actual value (6064 hex), set the value obtained by subtracting the Following error actual value (60F4 hex) from the Position Demand Value After Filtering (4018 hex).

Other than 3: A homing error (Homing error = 1) will occur.

[REFE]

0: The Homing not attained state is reached when this Homing method ends normally.

1: The Homing attained state is reached when this Homing method ends normally.

Note The REFE bits are enabled only when an incremental encoder is used.
An absolute encoder is always in a Homing attained state.

Set Value of the Coordinate System Setting Position (4104 hex) and Position Actual Value

Index	Sub	Name	R/W	Data type	Unit	Min	Max	Default
4104 hex	00 hex	POS_DATA (Coordinate System Setting Position)	rw	INT32	Command units	-2^{31} (8000 0000 hex)	$2^{31}-1$ (7FFF FFFF hex)	0

A-1-7 Object Dictionary

Object Dictionary Area

CAN application protocol over EtherCAT (CoE) uses the object dictionary as its base. All objects are assigned four-digit hexadecimal numbers in the areas shown in the following table.

Index	Area	Description
0000 to 0FFF hex	Data Type Area	Definitions of data types.
1000 to 1FFF hex	CoE Communication Area	Definitions of variables that can be used by all servers for designated communications.
2000 to 2FFF hex	Manufacturer Specific Area 1	Variables with common definitions for all OMRON products.
3000 to 5FFF hex	Manufacturer Specific Area 2	Variables with common definitions for all G5-series Servo Drives (servo parameters).
6000 to 9FFF hex	Device Profile Area	Variables defined in the Servo Drive's CiA402 drive profile.
A000 to FFFF hex	Reserved Area	Area reserved for future use.

Data Types

Data types shown in the following table are used in this profile.

Data Types	Code	Size	Range
Boolean	BOOL	1 bit	0 or 1
Unsigned 8	U8	1 byte	0 to 255
Unsigned 16	U16	2 bytes	0 to 65,535
Unsigned 32	U32	4 bytes	0 to 4,294,967,295
Integer 8	INT8	1 byte	-128 to 127
Integer 16	INT16	2 bytes	-32,768 to 32,767
Integer 32	INT32	4 bytes	-2,147,483,648 to 2,147,483,647
Visible string	VS	-	-
Octet string	OS	-	-

Object Description Format

In this manual, objects are described in the following format.

● Object Description Format

The object format is shown below.

<i><Index></i>	<i><Object name></i>					<i>Modes of Operation</i>	
Range	<i><Range></i>	Unit	<i><Unit></i>	Default	<i><Default></i>	Attribute	<i><Attribute></i>
Size	<i><Size></i>		Access	<i><Access></i>	PDO map	<i><Possible/Not possible></i>	

Data is indicated in pointed brackets <>.

Possible data are listed below.

Index: Object index given by a four-digit hexadecimal number.

Object name: The object name.

Modes of Operation:

Related operation modes.

Common: All operation modes

csp: Cyclic synchronous position mode

csv: Cyclic synchronous velocity mode

cst: Cyclic synchronous torque mode

pp: Profile position mode

hm: Homing mode

(Semi): Only operation modes related to semi-closed control.

(Full): Only operation modes related to fully-closed control.

Range: The possible range of settings.

Unit: Physical units.

Default: Default value set before shipment.

Attribute: The timing when a change in the contents is updated for a writable object.

A: Always updated

B: Changing prohibited during motor rotation or commands.

If a change is made during motor rotation or commands, the update timing is unknown.

C: Updated after the control power is reset, or after a Config command is executed via EtherCAT communications.

D: Changeable only when the EtherCAT communications state is Pre-Operational (Pre-Op).

R: Updated after the control power is reset.

It is not updated for a Config command via EtherCAT communications.

–: Write prohibited.

Size: The object size is given in bytes.

Access: Indicates whether the object is read only, or read and write.

RO: Read only.

RW: Read and write.

PDO map: Indicates the PDO mapping attribute.

Possible (RxPDO): Reception PDOs can be mapped.

Possible (TxPDO): Transmission PDOs can be mapped.

Not possible: PDOs cannot be mapped.

● **Format When There Is Sub-indexing**

The object description format with subindices is shown below.

<Index>	<Object name>						Modes of Operation	
Sub-index 00 hex		Number of entries						
Range	<Range>	Unit	<Unit>	Default	<Default>	Attribute	<Attribute>	
Size	<Size>		Access	<Access>	PDO map	<Possible/Not possible>		
Sub-index 01 hex		<Sub-index name>						
Range	<Range>	Unit	<Unit>	Default	<Default>	Attribute	<Attribute>	
Size	<Size>		Access	<Access>	PDO map	<Possible/Not possible>		
Sub-index 02 hex		<Sub-index name>						
Range	<Range>	Unit	<Unit>	Default	<Default>	Attribute	<Attribute>	
Size	<Size>		Access	<Access>	PDO map	<Possible/Not possible>		
:								
Sub-index NN hex		<Sub-index name>						
Range	<Range>	Unit	<Unit>	Default	<Default>	Attribute	<Attribute>	
Size	<Size>		Access	<Access>	PDO map	<Possible/Not possible>		

The data remains the same even with sub-indexing.

A-1-8 Communication Objects

1000 hex	Device Type						All	
Range	–	Unit	–	Default	0002 0192 hex	Attribute	–	
Size	4 bytes (U32)		Access	RO	PDO map	Not possible		

- Gives the CoE device profile number.

Description of Set Values

Bit	Name	Contents
0 to 15	Device profile number	402 (192 hex): Drive Profile
16 to 23	Type	02: Servo Drive
25 to 31	Mode	0: Manufacturer specific

1001 hex	Error Register						All
Range	–	Unit	–	Default	0	Attribute	–
Size	1 byte (U8)		Access	RO	PDO map	Not possible	

- Gives the error type that has occurred in the Servo Drive.

Description of Set Values

Bit	Description	Bit	Description
0	Generic error	4	Communication error
1	Current error	5	Device profile specific error
2	Voltage error	6	(Reserved)
3	Temperature error	7	Manufacturer specific error

1008 hex	Manufacturer Device Name						All
Range	–	Unit	–	Default	*1	Attribute	–
Size	20 bytes (VS)		Access	RO	PDO map	Not possible	

*1 The following table shows the default settings.

Specifications		Model
Single-phase 100 VAC	50 W	R88D-KNA5L-ECT
	100 W	R88D-KN01L-ECT
	200 W	R88D-KN02L-ECT
	400 W	R88D-KN04L-ECT
Single-phase/3-phase 200 VAC	100 W	R88D-KN01H-ECT
	200 W	R88D-KN02H-ECT
	400 W	R88D-KN04H-ECT
	750 W	R88D-KN08H-ECT
	1 kW	R88D-KN10H-ECT
	1.5 kW	R88D-KN15H-ECT
3-phase 200 VAC	2 kW	R88D-KN20H-ECT
	3 kW	R88D-KN30H-ECT
	5 kW	R88D-KN50H-ECT
	7.5 kW	R88D-KN75H-ECT
	15 kW	R88D-KN150H-ECT
3-phase 400 VAC	600 W	R88D-KN06F-ECT
	1 kW	R88D-KN10F-ECT
	1.5 kW	R88D-KN15F-ECT
	2 kW	R88D-KN20F-ECT
	3 kW	R88D-KN30F-ECT
	5 kW	R88D-KN50F-ECT
	7.5 kW	R88D-KN75F-ECT
	15 kW	R88D-KN150F-ECT

- Gives the Servo Drive model number.

1009 hex	Manufacturer Hardware Version						All
Range	–	Unit	–	Default	–	Attribute	–
Size	20 bytes (VS)		Access	RO	PDO map	Not possible	

- Gives the version of the Servo Drive hardware.
- This is not used by G5-series Servo Drives.

100A hex	Manufacturer Software Version						All
Range	–	Unit	–	Default	*1	Attribute	–
Size	20 bytes (VS)		Access	RO	PDO map	Not possible	

1 The version number is saved in “V.***”.

- Gives the version of the Servo Drive software.

1010 hex	Store Parameters						All
Sub-index 00 hex		Number of entries					
Range	–	Unit	–	Default	01 hex	Attribute	–
Size	1 byte (U8)		Access	RO	PDO map	Not possible	
Sub-index 01 hex		Store Parameters					
Range	–	Unit	–	Default	0000 0001 hex	Attribute	A
Size	4 bytes (U32)		Access	RW	PDO map	Not possible	

- All savable parameters are saved in the Servo Drive EEPROM.
- Saving is executed only when a specific value is written to sub-index 01 hex. This prevents parameter values from being accidentally overwritten.
- The specific value means “save”.

MSB		LSB	
e	v	a	s
65 hex	76 hex	61 hex	73 hex

- A value of 0000 0001 hex (command valid) is given when reading.
- Nothing can be saved to the EEPROM while there is a Control Power Supply Undervoltage Error (Error No. 11.0).
- Objects with attribute C are enabled for Config (4100 hex) or when the control power supply is reset.
- Objects with attribute R are enabled when the control power supply is reset.
- In the following cases, an ABORT code is returned.
 Writing with CompleteAccess.
 Writing a value other than 6576 6173 hex.
 Writing when there is a Control Power Supply Undervoltage Error (Error No. 11.0).
- Writing to the EEPROM may take up to 10 seconds. (This is when all objects are changed.)
- There is a limit to the number of times you can write to the EEPROM.
- The following objects are saved.

Index	Sub-index	Description
2200 hex	00 hex	Communications Error Setting
3000 to 3999 hex	00 hex	All G5-series Servo Drive parameters
605B hex	00 hex	Shutdown option code
605C hex	00 hex	Disable operation option code
605E hex	00 hex	Fault reaction option code

Index	Sub-index	Description
6065 hex	00 hex	Following error window
607C hex	00 hex	Home offset
607D hex	01 hex	Min position limit
607D hex	02 hex	Max position limit
6091 hex	01 hex	Motor revolutions
6091 hex	02 hex	Shaft revolutions

1011 hex	Restore Default Parameters						All		
Sub-index 00 hex		Number of entries							
Range	–	Unit	–	Default	01 hex	Attribute	–		
Size	1 byte (U8)		Access	RO	PDO map	Not possible			
Sub-index 01 hex		Restore all default parameters							
Range	–	Unit	–	Default	000 0001 hex	Attribute	A		
Size	4 bytes (U32)		Access	RW	PDO map	Not possible			

- Parameters are returned to their default values.
- A restoration operation is executed only when a specific value is written to sub-index 01 hex. This prevents parameter values from being accidentally overwritten.
- The specific value means “load.”

MSB		LSB	
d	a	o	l
64 hex	61 hex	6F hex	6C hex

- A value of 0000 0001 hex (command valid) is given when reading.
- EEPROM contents cannot be reset to default values if there is a Control Power Supply Undervoltage Error (Error No. 11.0).
- Reset the control power supply to enable the objects.
- In the following cases, an ABORT code is returned.
 - Writing with CompleteAccess.
 - Writing a value other than 6461 6F6C hex.
 - Writing when there is a Control Power Supply Undervoltage Error (Error No. 11.0).
 - Writing in operation enabled state.
- Writing to the EEPROM may take up to 10 seconds. (This is when all objects are changed.)
- There is a limit to the number of times you can write to the EEPROM.

1018 hex		Identity Object						All
Sub-index 00 hex		Number of entries						
Range	–	Unit	–	Default	04 hex	Attribute	–	
Size	1 byte (U8)		Access	RO	PDO map	Not possible		
Sub-index 01 hex		Vendor ID						
Range	–	Unit	–	Default	0000 0083 hex	Attribute	–	
Size	4 bytes (U32)		Access	RO	PDO map	Not possible		
Sub-index 02 hex		Product Code						
Range	–	Unit	–	Default	Refer to the table.	Attribute	–	
Size	4 bytes (U32)		Access	RO	PDO map	Not possible		
Sub-index 03 hex		Revision Number						
Range	–	Unit	–	Default	Refer to the table.	Attribute	–	
Size	4 bytes (U32)		Access	RO	PDO map	Not possible		
Sub-index 04 hex		Serial Number						
Range	–	Unit	–	Default	Refer to the description.	Attribute	–	
Size	4 bytes (U32)		Access	RO	PDO map	Not possible		

- This object contains device information.
- Sub-index 01 hex (Vendor ID) gives the manufacturer identifier.
- Sub-index 02 hex (Product Code) gives the value assigned to each device.
- Sub-index 03 hex (Revision Number) gives the device revision number.

Specifications	Model	Product code	
Single-phase 100 VAC	50 W	R88D-KNA5L-ECT	00000001 hex
	100 W	R88D-KN01L-ECT	00000002 hex
	200 W	R88D-KN02L-ECT	00000003 hex
	400 W	R88D-KN04L-ECT	00000004 hex
Single-phase/3-phase 200 VAC	100 W	R88D-KN01H-ECT	00000005 hex
	200 W	R88D-KN02H-ECT	00000006 hex
	400 W	R88D-KN04H-ECT	00000007 hex
	750 W	R88D-KN08H-ECT	00000008 hex
	1 kW	R88D-KN10H-ECT	00000009 hex
	1.5 kW	R88D-KN15H-ECT	0000000A hex
3-phase 200 VAC	2 kW	R88D-KN20H-ECT	00000056 hex
	3 kW	R88D-KN30H-ECT	00000057 hex
	5 kW	R88D-KN50H-ECT	00000058 hex
	7.5 kW	R88D-KN75H-ECT	00000059 hex
	15 kW	R88D-KN150H-ECT	0000005A hex
3-phase 400 VAC	600 W	R88D-KN06F-ECT	0000000B hex
	1 kW	R88D-KN10F-ECT	0000000C hex
	1.5 kW	R88D-KN15F-ECT	0000000D hex
	2 kW	R88D-KN20F-ECT	0000005B hex
	3 kW	R88D-KN30F-ECT	0000005C hex
	5 kW	R88D-KN50F-ECT	0000005D hex
	7.5 kW	R88D-KN75F-ECT	0000005E hex
	15 kW	R88D-KN150F-ECT	0000005F hex

Bits	Description
0 to 15	Device's minor revision number
16 to 31	Device's major revision number

- Sub-index 04 hex (Serial Number) gives the device serial number controlled by OMRON. For unit version 2.0, 0000 0000 hex is always displayed.

10F0 hex	Backup Parameters Mode All						
Sub-index 00 hex		Number of entries					
Range	–	Unit	–	Default	02 hex	Attribute	–
Size	1 byte (U8)		Access	RO	PDO map	Not possible	
Sub-index 01 hex		Backup Parameter Checksum					
Range	–	Unit	–	Default	–	Attribute	–
Size	4 bytes (U32)		Access	RO	PDO map	Not possible	
Sub-index 02 hex		Backup Parameter Changed					
Range	–	Unit	–	Default	0	Attribute	A
Size	1 bit (BOOL)		Access	RW	PDO map	Not possible	

- This object gives the state of EEPROM changes.
- Sub-index 01 hex (Backup Parameter Checksum) gives the EEPROM's checksum value. The checksum value is calculated based on objects saved for Store parameters (1010 hex).
- Sub-index 02 hex (Backup Parameter Changed) gives 1 when the EEPROM is changed. After you have checked that it is 1, write 0 to it from the Master.

10F3 hex	Diagnosis History All						
Sub-index 00 hex		Number of entries					
Range	–	Unit	–	Default	13 hex	Attribute	–
Size	1 byte (U8)		Access	RO	PDO map	Not possible	
Sub-index 01 hex		Maximum Messages					
Range	00 to 0E hex	Unit	–	Default	00 hex	Attribute	–
Size	1 byte (U8)		Access	RO	PDO map	Not possible	
Sub-index 02 hex		Newest Message					
Range	06 to 13 hex	Unit	–	Default	06 hex	Attribute	–
Size	1 byte (U8)		Access	RO	PDO map	Not possible	
Sub-index 05 hex		Flags					
Range	0000 to 0001 hex	Unit	–	Default	0000 hex	Attribute	A
Size	2 bytes (U16)		Access	RW	PDO map	Not possible	
Sub-indices 06 to 13 hex		Diagnosis Messages 1 to 14					
Range	–	Unit	–	Default	–	Attribute	–
Size	23 bytes (VS)*1		Access	RO	PDO map	Not possible	

*1 The size for unit version 2.0 or earlier is 16 bytes (VS).

- This object gives up to 14 error history items. It also enables/disables emergency messages.
- Sub-index 01 hex (Maximum Messages) gives the number of error messages.
- Sub-index 02 hex (Newest Message) gives the sub index where the latest error history is saved.
- Sub-index 05 hex (Flags) sets whether or not to notify the error history as an emergency message. It is set to Emergency Message Disabled (0000 hex) when power is turned ON. Write 0001 hex from the master to enable this function.

- Sub-indexes 06 to 13 hex (Diagnosis Messages 1 to 14) give the error history. The error history is saved in Diagnosis Messages 1 to 14 in ascending order. When the 15th error is reached, it is saved as Diagnosis Message 1 and the sequence starts again.

Details on Error Log

Unit Version 2.1

Contents	Size	Details
(Reserved)	18 bytes	This area is reserved.
Manufacturer Specific Error Field	5 bytes	The upper byte is not used. The lower four bytes contain the event code for the error. Example: For a Communications Setting Error (event code 84B80000 hex), 000000B884 hex would be stored.

Unit Version 2.0 or Earlier

Contents	Size	Details
(Reserved)	16 bytes	This area is reserved.

A-1-9 PDO Mapping Objects

Indexes 1600 to 17FF hex are used for Receive PDO mapping and indexes 1A00 to 1BFF hex are used for Transmit PDO mapping. Sub-indexes after sub-index 01 hex provide information about the application object being mapped.

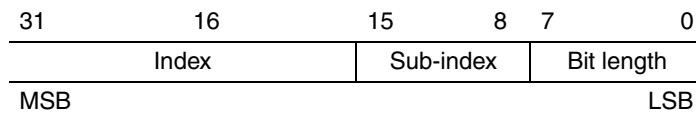

Bits 0 to 7: Bit length of the mapped object. (For example, for 32 bits, 20 hex is given.)

Bits 8 to 15: Sub-index of the mapped object.

Bits 16 to 31: Index of the mapped object.

1600 hex	1st receive PDO Mapping						All
Sub-index 00 hex	Number of objects in this PDO						
Setting range	00 to 0A hex	Unit	–	Default setting	03 hex	Attribute	D
Size	1 byte (U8)	Access	RW	PDO map	Not possible.		
Sub-index 01 hex	PDO entry 1 (1st Output Object to be mapped)						
Setting range	–	Unit	–	Default setting	6040 0010 hex	Attribute	D
Size	4 byte (U32)	Access	RW	PDO map	Not possible.		
Sub-index 02 hex	PDO entry 2 (2nd Output Object to be mapped)						
Setting range	–	Unit	–	Default setting	607A 0020 hex	Attribute	D
Size	4 byte (U32)	Access	RW	PDO map	Not possible.		
Sub-index 03 hex	PDO entry 3 (3rd Output Object to be mapped)						
Setting range	–	Unit	–	Default setting	60B8 0010 hex	Attribute	D
Size	4 byte (U32)	Access	RW	PDO map	Not possible.		
Sub-index 04 hex	PDO entry 4 (4th Output Object to be mapped)						
Setting range	–	Unit	–	Default setting	0000 0000 hex	Attribute	D
Size	4 byte (U32)	Access	RW	PDO map	Not possible.		
Sub-index 05 hex	PDO entry 5 (5th Output Object to be mapped)						
Setting range	–	Unit	–	Default setting	0000 0000 hex	Attribute	D
Size	4 byte (U32)	Access	RW	PDO map	Not possible.		
Sub-index 06 hex	PDO entry 6 (6th Output Object to be mapped)						
Setting range	–	Unit	–	Default setting	0000 0000 hex	Attribute	D
Size	4 byte (U32)	Access	RW	PDO map	Not possible.		
Sub-index 07 hex	PDO entry 7 (7th Output Object to be mapped)						
Setting range	–	Unit	–	Default setting	0000 0000 hex	Attribute	D
Size	4 byte (U32)	Access	RW	PDO map	Not possible.		
Sub-index 08 hex	PDO entry 8 (8th Output Object to be mapped)						
Setting range	–	Unit	–	Default setting	0000 0000 hex	Attribute	D
Size	4 byte (U32)	Access	RW	PDO map	Not possible.		
Sub-index 09 hex	PDO entry 9 (9th Output Object to be mapped)						
Setting range	–	Unit	–	Default setting	0000 0000 hex	Attribute	D
Size	4 byte (U32)	Access	RW	PDO map	Not possible.		
Sub-index 0A hex	PDO entry 10 (10th Output Object to be mapped)						
Setting range	–	Unit	–	Default setting	0000 0000 hex	Attribute	D
Size	4 byte (U32)	Access	RW	PDO map	Not possible.		

- These object mappings can be changed only when the EtherCAT communications state is Pre-Operational (Pre-Op).

- Since the mappings you changed are not saved in EEPROM, you must specify objects each time you turn ON the power of the G5-series Servo Drive in order to use the mapping other than the default setting.
- You can map up to 10 objects in a PDO mapping. If you attempt to map 11 or more objects, a Function Setting Error (Error No. 93.4) will occur.
- The communications cycle you can set varies depending on the total size of mapped objects. Refer to *A-1-3 Communications Cycles and Corresponding Modes of Operation* on page A-5. If the number of the mapped objects is 0, a Function Setting Error (Error No. 93.4) will occur.
- If you map the same object more than once, the value of the last object will be enabled.
- If any of the following operations is attempted, an ABORT code will be returned.
 - Writing when the EtherCAT communications state is Safe-Operational (Safe-Op) or Operational (Op)
 - Writing with non-existent objects specified
 - Writing with incorrect object size specified
 - Writing with objects that cannot be mapped in the PDO mapping specified
- The following objects can be mapped to the Receive PDO mapping.

Index	Sub-Index	Bit length	Object name
4103 hex	00 hex	10 hex	Coordinate System Setting Mode
4104 hex	00 hex	20 hex	Coordinate System Setting Position
6040 hex	00 hex	10 hex	Controlword
6060 hex	00 hex	08 hex	Modes of operation
6071 hex	00 hex	10 hex	Target torque
6072 hex	00 hex	10 hex	Max torque
607A hex	00 hex	20 hex	Target position
607F hex	00 hex	20 hex	Max profile velocity
6081 hex	00 hex	20 hex	Profile velocity
6086 hex	00 hex	10 hex	Motion profile type
60B0 hex	00 hex	20 hex	Position offset
60B1 hex	00 hex	20 hex	Velocity offset
60B2 hex	00 hex	10 hex	Torque offset
60B8 hex	00 hex	10 hex	Touch probe function
60E0 hex	00 hex	10 hex	Positive torque limit value
60E1 hex	00 hex	10 hex	Negative torque limit value
60FE hex	01 hex	20 hex	Physical outputs
60FF hex	00 hex	20 hex	Target velocity

1701 hex	258th receive PDO Mapping						All	
Sub-index 00 hex		Number of objects in this PDO						
Range	–	Unit	–	Default	04 hex	Attribute	–	
Size	1 byte (U8)		Access	RO	PDO map	Not possible		
Sub-index 01 hex		PDO entry 1 (1st Output Object to be mapped)						
Range	–	Unit	–	Default	6040 0010 hex	Attribute	–	
Size	4 bytes (U32)		Access	RO	PDO map	Not possible		
Sub-index 02 hex		PDO entry 2 (2nd Output Object to be mapped)						
Range	–	Unit	–	Default	607A 0020 hex	Attribute	–	
Size	4 bytes (U32)		Access	RO	PDO map	Not possible		
Sub-index 03 hex		PDO entry 3 (3rd Output Object to be mapped)						
Range	–	Unit	–	Default	60B8 0010 hex	Attribute	–	
Size	4 bytes (U32)		Access	RO	PDO map	Not possible		
Sub-index 04 hex		PDO entry 4 (4th Output Object to be mapped)						
Range	–	Unit	–	Default	60FE 0120 hex	Attribute	–	
Size	4 bytes (U32)		Access	RO	PDO map	Not possible		

- This object gives the mapping for an application that uses only cyclic synchronous position control (csp).
- Touch probe function is available.
- The following objects are mapped.
 Controlword (6040 hex), Target position (607A hex), Touch probe function (60B8 hex), and Digital outputs (60FE hex)

1702 hex		259th receive PDO Mapping						All
Sub-index 00 hex		Number of objects in this PDO						
Range	–	Unit	–	Default	07 hex	Attribute	–	
Size	1 byte (U8)		Access	RO	PDO map	Not possible		
Sub-index 01 hex		PDO entry 1 (1st Output Object to be mapped)						
Range	–	Unit	–	Default	6040 0010 hex	Attribute	–	
Size	4 bytes (U32)		Access	RO	PDO map	Not possible		
Sub-index 02 hex		PDO entry 2 (2nd Output Object to be mapped)						
Range	–	Unit	–	Default	607A 0020 hex	Attribute	–	
Size	4 bytes (U32)		Access	RO	PDO map	Not possible		
Sub-index 03 hex		PDO entry 3 (3rd Output Object to be mapped)						
Range	–	Unit	–	Default	60FF 0020 hex	Attribute	–	
Size	4 bytes (U32)		Access	RO	PDO map	Not possible		
Sub-index 04 hex		PDO entry 4 (4th Output Object to be mapped)						
Range	–	Unit	–	Default	6071 0010 hex	Attribute	–	
Size	4 bytes (U32)		Access	RO	PDO map	Not possible		
Sub-index 05 hex		PDO entry 5 (5th Output Object to be mapped)						
Range	–	Unit	–	Default	6060 0008 hex	Attribute	–	
Size	4 bytes (U32)		Access	RO	PDO map	Not possible		
Sub-index 06 hex		PDO entry 6 (6th Output Object to be mapped)						
Range	–	Unit	–	Default	60B8 0010 hex	Attribute	–	
Size	4 bytes (U32)		Access	RO	PDO map	Not possible		
Sub-index 07 hex		PDO entry 7 (7th Output Object to be mapped)						
Range	–	Unit	–	Default	607F 0020 hex	Attribute	–	
Size	4 bytes (U32)		Access	RO	PDO map	Not possible		

- This is the mapping for an application that uses one of the following modes: Cyclic synchronous position mode (csp), Cyclic synchronous velocity mode (csv), and Cyclic synchronous torque mode (cst).
- Touch probe function is available.

1703 hex	260th receive PDO Mapping						All	
Sub-index 00 hex		Number of objects in this PDO						
Range	–	Unit	–	Default	07 hex	Attribute	–	
Size	1 byte (U8)		Access	RO	PDO map	Not possible		
Sub-index 01 hex		PDO entry 1 (1st Output Object to be mapped)						
Range	–	Unit	–	Default	6040 0010 hex	Attribute	–	
Size	4 bytes (U32)		Access	RO	PDO map	Not possible		
Sub-index 02 hex		PDO entry 2 (2nd Output Object to be mapped)						
Range	–	Unit	–	Default	607A 0020 hex	Attribute	–	
Size	4 bytes (U32)		Access	RO	PDO map	Not possible		
Sub-index 03 hex		PDO entry 3 (3rd Output Object to be mapped)						
Range	–	Unit	–	Default	60FF 0020 hex	Attribute	–	
Size	4 bytes (U32)		Access	RO	PDO map	Not possible		
Sub-index 04 hex		PDO entry 4 (4th Output Object to be mapped)						
Range	–	Unit	–	Default	6060 0008 hex	Attribute	–	
Size	4 bytes (U32)		Access	RO	PDO map	Not possible		
Sub-index 05 hex		PDO entry 5 (5th Output Object to be mapped)						
Range	–	Unit	–	Default	60B8 0010 hex	Attribute	–	
Size	4 bytes (U32)		Access	RO	PDO map	Not possible		
Sub-index 06 hex		PDO entry 6 (6th Output Object to be mapped)						
Range	–	Unit	–	Default	60E0 0010 hex	Attribute	–	
Size	4 bytes (U32)		Access	RO	PDO map	Not possible		
Sub-index 07 hex		PDO entry 7 (7th Output Object to be mapped)						
Range	–	Unit	–	Default	60E1 0010 hex	Attribute	–	
Size	4 bytes (U32)		Access	RO	PDO map	Not possible		

- This is the mapping for an application that switches between Cyclic synchronous position mode (csp) and Cyclic synchronous velocity mode (csv).
- Touch probe and torque control are available.

1704 hex		261th receive PDO Mapping						All
Sub-index 00 hex		Number of objects in this PDO						
Range	–	Unit	–	Default	09 hex	Attribute	–	
Size	1 byte (U8)		Access	RO	PDO map	Not possible		
Sub-index 01 hex		PDO entry 1 (1st Output Object to be mapped)						
Range	–	Unit	–	Default	6040 0010 hex	Attribute	–	
Size	4 bytes (U32)		Access	RO	PDO map	Not possible		
Sub-index 02 hex		PDO entry 2 (2nd Output Object to be mapped)						
Range	–	Unit	–	Default	607A 0020 hex	Attribute	–	
Size	4 bytes (U32)		Access	RO	PDO map	Not possible		
Sub-index 03 hex		PDO entry 3 (3rd Output Object to be mapped)						
Range	–	Unit	–	Default	60FF 0020 hex	Attribute	–	
Size	4 bytes (U32)		Access	RO	PDO map	Not possible		
Sub-index 04 hex		PDO entry 4 (4th Output Object to be mapped)						
Range	–	Unit	–	Default	6071 0010 hex	Attribute	–	
Size	4 bytes (U32)		Access	RO	PDO map	Not possible		
Sub-index 05 hex		PDO entry 5 (5th Output Object to be mapped)						
Range	–	Unit	–	Default	6060 0008 hex	Attribute	–	
Size	4 bytes (U32)		Access	RO	PDO map	Not possible		
Sub-index 06 hex		PDO entry 6 (6th Output Object to be mapped)						
Range	–	Unit	–	Default	60B8 0010 hex	Attribute	–	
Size	4 bytes (U32)		Access	RO	PDO map	Not possible		
Sub-index 07 hex		PDO entry 7 (7th Output Object to be mapped)						
Range	–	Unit	–	Default	607F 0020 hex	Attribute	–	
Size	4 bytes (U32)		Access	RO	PDO map	Not possible		
Sub-index 08 hex		PDO entry 8 (8th Output Object to be mapped)						
Range	–	Unit	–	Default	60E0 0010 hex	Attribute	–	
Size	4 bytes (U32)		Access	RO	PDO map	Not possible		
Sub-index 09 hex		PDO entry 9 (9th Output Object to be mapped)						
Range	–	Unit	–	Default	60E1 0010 hex	Attribute	–	
Size	4 bytes (U32)		Access	RO	PDO map	Not possible		

- This is the mapping for an application that uses one of the following modes: Cyclic synchronous position mode (csp), Cyclic synchronous velocity mode (csv), and Cyclic synchronous torque mode (cst).
- Touch probe and torque control are available.

1705 hex	262th receive PDO Mapping						All	
Sub-index 00 hex		Number of objects in this PDO						
Range	–	Unit	–	Default	08 hex	Attribute	–	
Size	1 byte (U8)		Access	RO	PDO map	Not possible		
Sub-index 01 hex		PDO entry 1 (1st Output Object to be mapped)						
Range	–	Unit	–	Default	6040 0010 hex	Attribute	–	
Size	4 bytes (U32)		Access	RO	PDO map	Not possible		
Sub-index 02 hex		PDO entry 2 (2nd Output Object to be mapped)						
Range	–	Unit	–	Default	607A 0020 hex	Attribute	–	
Size	4 bytes (U32)		Access	RO	PDO map	Not possible		
Sub-index 03 hex		PDO entry 3 (3rd Output Object to be mapped)						
Range	–	Unit	–	Default	60FF 0020 hex	Attribute	–	
Size	4 bytes (U32)		Access	RO	PDO map	Not possible		
Sub-index 04 hex		PDO entry 4 (4th Output Object to be mapped)						
Range	–	Unit	–	Default	6060 0008 hex	Attribute	–	
Size	4 bytes (U32)		Access	RO	PDO map	Not possible		
Sub-index 05 hex		PDO entry 5 (5th Output Object to be mapped)						
Range	–	Unit	–	Default	60B8 0010 hex	Attribute	–	
Size	4 bytes (U32)		Access	RO	PDO map	Not possible		
Sub-index 06 hex		PDO entry 6 (6th Output Object to be mapped)						
Range	–	Unit	–	Default	60E0 0010 hex	Attribute	–	
Size	4 bytes (U32)		Access	RO	PDO map	Not possible		
Sub-index 07 hex		PDO entry 7 (7th Output Object to be mapped)						
Range	–	Unit	–	Default	60E1 0010 hex	Attribute	–	
Size	4 bytes (U32)		Access	RO	PDO map	Not possible		
Sub-index 08 hex		PDO entry 8 (8th Output Object to be mapped)						
Range	–	Unit	–	Default	60B2 0010 hex	Attribute	–	
Size	4 bytes (U32)		Access	RO	PDO map	Not possible		

- This is the mapping for an application that switches between Cyclic synchronous position mode (csp) and Cyclic synchronous velocity mode (csv).
- Touch probe and torque control are available.
- The torque feed-forward amount can be specified using the Torque offset (60B2 hex).

1A00 hex		1st transmit PDO Mapping					All	
Sub-index 00 hex		Number of objects in this PDO						
Setting range	00 to 0A hex	Unit	–	Default	07 hex	Attribute	D	
Size	1 byte (U8)		Access	RW	PDO map	Not possible		
Sub-index 01 hex		PDO entry 1 (1st Input Object to be mapped)						
Setting range	–	Unit	–	Default setting	6041 0010 hex	Attribute	D	
Size	4 byte (U32)		Access	RW	PDO map	Not possible.		
Sub-index 02 hex		PDO entry 2 (2nd Input Object to be mapped)						
Setting range	–	Unit	–	Default setting	6064 0020 hex	Attribute	D	
Size	4 byte (U32)		Access	RW	PDO map	Not possible.		
Sub-index 03 hex		PDO entry 3 (3rd Input Object to be mapped)						
Setting range	–	Unit	–	Default setting	60B9 0010 hex	Attribute	D	
Size	4 byte (U32)		Access	RW	PDO map	Not possible.		
Sub-index 04 hex		PDO entry 4 (4th Input Object to be mapped)						
Setting range	–	Unit	–	Default setting	60BA 0020 hex	Attribute	D	
Size	4 byte (U32)		Access	RW	PDO map	Not possible.		
Sub-index 05 hex		PDO entry 5 (5th Input Object to be mapped)						
Setting range	–	Unit	–	Default setting	60BC 0020 hex	Attribute	D	
Size	4 byte (U32)		Access	RW	PDO map	Not possible.		
Sub-index 06 hex		PDO entry 6 (6th Input Object to be mapped)						
Setting range	–	Unit	–	Default setting	603F 0010 hex	Attribute	D	
Size	4 byte (U32)		Access	RW	PDO map	Not possible.		
Sub-index 07 hex		PDO entry 7 (7th Input Object to be mapped)						
Setting range	–	Unit	–	Default setting	60FD 0020 hex	Attribute	D	
Size	4 byte (U32)		Access	RW	PDO map	Not possible.		
Sub-index 08 hex		PDO entry 8 (8th Input Object to be mapped)						
Setting range	–	Unit	–	Default setting	0000 0000 hex	Attribute	D	
Size	4 byte (U32)		Access	RW	PDO map	Not possible.		
Sub-index 09 hex		PDO entry 9 (9th Input Object to be mapped)						
Setting range	–	Unit	–	Default setting	0000 0000 hex	Attribute	D	
Size	4 byte (U32)		Access	RW	PDO map	Not possible.		
Sub-index 0A hex		PDO entry 10 (10th Input Object to be mapped)						
Setting range	–	Unit	–	Default setting	0000 0000 hex	Attribute	D	
Size	4 byte (U32)		Access	RW	PDO map	Not possible.		

- These object mappings can be changed only when the EtherCAT communications state is Pre-Operational (Pre-Op).
- Since the mappings you changed are not saved in EEPROM, you must specify objects each time you turn ON the power of the G5-series Servo Drive in order to use the mapping other than the default setting.
- You can map up to 10 objects in a PDO mapping. If you attempt to map 11 or more objects, a Function Setting Error (Error No. 93.4) will occur.
- The communications cycle you can set varies depending on the total size of mapped objects. Refer to *A-1-3 Communications Cycles and Corresponding Modes of Operation* on page A-5.
- If the number of the mapped objects is 0, a Function Setting Error (Error No. 93.4) will occur.
- If you map the same object more than once, the value of the last object will be enabled.
- If any of the following operations is attempted, an ABORT code will be returned.
 - Writing when the EtherCAT communications state is Safe-Operational (Safe-Op) or Operational (Op)
 - Writing with non-existent objects specified
 - Writing with incorrect object size specified
 - Writing with objects that cannot be mapped in the PDO mapping specified

- The following objects can be mapped to the Receive PDO mapping.

Index	Sub-Index	Bit length	Object name
2002 hex	01 hex	08 hex	Sysmac Error Status
4000 hex	00 hex	10 hex	Statusword1
4001 hex	00 hex	10 hex	Sub Error Code
4020 hex ^{*1}	00 hex	20 hex	Reference Position for CSP
603F hex	00 hex	10 hex	Error code
6041 hex	00 hex	10 hex	Statusword
6061 hex	00 hex	08 hex	Modes of operation display
6062 hex	00 hex	20 hex	Position demand value
6063 hex	00 hex	20 hex	Position actual internal value
6064 hex	00 hex	20 hex	Position actual value
606C hex	00 hex	20 hex	Velocity actual value
6074 hex	00 hex	10 hex	Torque demand
6077 hex	00 hex	10 hex	Torque actual value
60B9 hex	00 hex	10 hex	Touch probe status
60BA hex	00 hex	20 hex	Touch probe pos1 pos value
60BC hex	00 hex	20 hex	Touch probe pos2 pos value
60F4 hex	00 hex	20 hex	Following error actual value
60FA hex	00 hex	20 hex	Control effort
60FC hex	00 hex	20 hex	Position demand internal value
60FD hex	00 hex	20 hex	Digital inputs

*1 If you map 4020 hex when the communications cycle is set to 250/500 μs or when the electronic gear object ratio is not 1:1, a Function Setting Error (Error No. 93.4) will occur.

1B01 hex		258th transmit PDO Mapping						All
Sub-index 00 hex		Number of objects in this PDO						
Range	–	Unit	–	Default	09 hex	Attribute	–	
Size	1 byte (U8)		Access	RO	PDO map	Not possible		
Sub-index 01 hex		PDO entry 1 (1st Input Object to be mapped)						
Range	–	Unit	–	Default	603F 0010 hex	Attribute	–	
Size	4 bytes (U32)		Access	RO	PDO map	Not possible		
Sub-index 02 hex		PDO entry 2 (2nd Input Object to be mapped)						
Range	–	Unit	–	Default	6041 0010 hex	Attribute	–	
Size	4 bytes (U32)		Access	RO	PDO map	Not possible		
Sub-index 03 hex		PDO entry 3 (3rd Input Object to be mapped)						
Range	–	Unit	–	Default	6064 0020 hex	Attribute	–	
Size	4 bytes (U32)		Access	RO	PDO map	Not possible		
Sub-index 04 hex		PDO entry 4 (4th Input Object to be mapped)						
Range	–	Unit	–	Default	6077 0010 hex	Attribute	–	
Size	4 bytes (U32)		Access	RO	PDO map	Not possible		
Sub-index 05 hex		PDO entry 5 (5th Input Object to be mapped)						
Range	–	Unit	–	Default	60F4 0020 hex	Attribute	–	
Size	4 bytes (U32)		Access	RO	PDO map	Not possible		
Sub-index 06 hex		PDO entry 6 (6th Input Object to be mapped)						
Range	–	Unit	–	Default	60B9 0010 hex	Attribute	–	
Size	4 bytes (U32)		Access	RO	PDO map	Not possible		
Sub-index 07 hex		PDO entry 7 (7th Input Object to be mapped)						
Range	–	Unit	–	Default	60BA 0020 hex	Attribute	–	
Size	4 bytes (U32)		Access	RO	PDO map	Not possible		
Sub-index 08 hex		PDO entry 8 (8th Input Object to be mapped)						
Range	–	Unit	–	Default	60BC 0020 hex	Attribute	–	
Size	4 bytes (U32)		Access	RO	PDO map	Not possible		
Sub-index 09 hex		PDO entry 9 (9th Input Object to be mapped)						
Range	–	Unit	–	Default	60FD 0020 hex	Attribute	–	
Size	4 bytes (U32)		Access	RO	PDO map	Not possible		

- This object gives the mapping for an application that uses only cyclic synchronous position control (csp).
- Touch probe status is available.
- The following objects are mapped.

Error code (603F hex), Statusword (6041 hex), Position actual value (6064 hex), Torque actual value (6077 hex), Following error actual value (60F4 hex), Touch probe status (60B9 hex), Touch probe pos1 pos value (60BA hex), Touch probe pos2 pos value (60BC hex), and Digital inputs (60FD hex)

1B02 hex		259th transmit PDO Mapping						All	
Sub-index 00 hex		Number of objects in this PDO							
Range	–	Unit	–	Default	09 hex	Attribute	–		
Size	1 byte (U8)		Access	RO	PDO map	Not possible			
Sub-index 01 hex		PDO entry 1 (1st Input Object to be mapped)							
Range	–	Unit	–	Default	603F 0010 hex	Attribute	–		
Size	4 bytes (U32)		Access	RO	PDO map	Not possible			
Sub-index 02 hex		PDO entry 2 (2nd Input Object to be mapped)							
Range	–	Unit	–	Default	6041 0010 hex	Attribute	–		
Size	4 bytes (U32)		Access	RO	PDO map	Not possible			
Sub-index 03 hex		PDO entry 3 (3rd Input Object to be mapped)							
Range	–	Unit	–	Default	6064 0020 hex	Attribute	–		
Size	4 bytes (U32)		Access	RO	PDO map	Not possible			
Sub-index 04 hex		PDO entry 4 (4th Input Object to be mapped)							
Range	–	Unit	–	Default	6077 0010 hex	Attribute	–		
Size	4 bytes (U32)		Access	RO	PDO map	Not possible			
Sub-index 05 hex		PDO entry 5 (5th Input Object to be mapped)							
Range	–	Unit	–	Default	6061 0008 hex	Attribute	–		
Size	4 bytes (U32)		Access	RO	PDO map	Not possible			
Sub-index 06 hex		PDO entry 6 (6th Input Object to be mapped)							
Range	–	Unit	–	Default	60B9 0010 hex	Attribute	–		
Size	4 bytes (U32)		Access	RO	PDO map	Not possible			
Sub-index 07 hex		PDO entry 7 (7th Input Object to be mapped)							
Range	–	Unit	–	Default	60BA 0020 hex	Attribute	–		
Size	4 bytes (U32)		Access	RO	PDO map	Not possible			
Sub-index 08 hex		PDO entry 8 (8th Input Object to be mapped)							
Range	–	Unit	–	Default	60BC 0020 hex	Attribute	–		
Size	4 bytes (U32)		Access	RO	PDO map	Not possible			
Sub-index 09 hex		PDO entry 9 (9th Input Object to be mapped)							
Range	–	Unit	–	Default	60FD 0020 hex	Attribute	–		
Size	4 bytes (U32)		Access	RO	PDO map	Not possible			

- This is the mapping for an application that uses different modes of operation.
- Touch probe status is available.

1B03 hex		260th transmit PDO Mapping						All
Sub-index 00 hex		Number of objects in this PDO						
Range	–	Unit	–	Default	0A hex	Attribute	–	
Size	1 byte (U8)		Access	RO	PDO map	Not possible		
Sub-index 01 hex		PDO entry 1 (1st Input Object to be mapped)						
Range	–	Unit	–	Default	603F 0010 hex	Attribute	–	
Size	4 bytes (U32)		Access	RO	PDO map	Not possible		
Sub-index 02 hex		PDO entry 2 (2nd Input Object to be mapped)						
Range	–	Unit	–	Default	6041 0010 hex	Attribute	–	
Size	4 bytes (U32)		Access	RO	PDO map	Not possible		
Sub-index 03 hex		PDO entry 3 (3rd Input Object to be mapped)						
Range	–	Unit	–	Default	6064 0020 hex	Attribute	–	
Size	4 bytes (U32)		Access	RO	PDO map	Not possible		
Sub-index 04 hex		PDO entry 4 (4th Input Object to be mapped)						
Range	–	Unit	–	Default	6077 0010 hex	Attribute	–	
Size	4 bytes (U32)		Access	RO	PDO map	Not possible		
Sub-index 05 hex		PDO entry 5 (5th Input Object to be mapped)						
Range	–	Unit	–	Default	60F4 0020 hex	Attribute	–	
Size	4 bytes (U32)		Access	RO	PDO map	Not possible		
Sub-index 06 hex		PDO entry 6 (6th Input Object to be mapped)						
Range	–	Unit	–	Default	6061 0008 hex	Attribute	–	
Size	4 bytes (U32)		Access	RO	PDO map	Not possible		
Sub-index 07 hex		PDO entry 7 (7th Input Object to be mapped)						
Range	–	Unit	–	Default	60B9 0010 hex	Attribute	–	
Size	4 bytes (U32)		Access	RO	PDO map	Not possible		
Sub-index 08 hex		PDO entry 8 (8th Input Object to be mapped)						
Range	–	Unit	–	Default	60BA 0020 hex	Attribute	–	
Size	4 bytes (U32)		Access	RO	PDO map	Not possible		
Sub-index 09 hex		PDO entry 9 (9th Input Object to be mapped)						
Range	–	Unit	–	Default	60BC 0020 hex	Attribute	–	
Size	4 bytes (U32)		Access	RO	PDO map	Not possible		
Sub-index 0A hex		PDO entry 10 (10th Input Object to be mapped)						
Range	–	Unit	–	Default	60FD 0020 hex	Attribute	–	
Size	4 bytes (U32)		Access	RO	PDO map	Not possible		

- This is the mapping for an application that uses different modes of operation.
- Touch probe status is available.
- Following error actual value (60F4 hex) is provided.

1B04 hex		261th transmit PDO Mapping						All	
Sub-index 00 hex		Number of objects in this PDO							
Range	–	Unit	–	Default	0A hex	Attribute	–		
Size	1 byte (U8)		Access	RO	PDO map	Not possible			
Sub-index 01 hex		PDO entry 1 (1st Input Object to be mapped)							
Range	–	Unit	–	Default	603F 0010 hex	Attribute	–		
Size	4 bytes (U32)		Access	RO	PDO map	Not possible			
Sub-index 02 hex		PDO entry 2 (2nd Input Object to be mapped)							
Range	–	Unit	–	Default	6041 0010 hex	Attribute	–		
Size	4 bytes (U32)		Access	RO	PDO map	Not possible			
Sub-index 03 hex		PDO entry 3 (3rd Input Object to be mapped)							
Range	–	Unit	–	Default	6064 0020 hex	Attribute	–		
Size	4 bytes (U32)		Access	RO	PDO map	Not possible			
Sub-index 04 hex		PDO entry 4 (4th Input Object to be mapped)							
Range	–	Unit	–	Default	6077 0010 hex	Attribute	–		
Size	4 bytes (U32)		Access	RO	PDO map	Not possible			
Sub-index 05 hex		PDO entry 5 (5th Input Object to be mapped)							
Range	–	Unit	–	Default	6061 0008 hex	Attribute	–		
Size	4 bytes (U32)		Access	RO	PDO map	Not possible			
Sub-index 06 hex		PDO entry 6 (6th Input Object to be mapped)							
Range	–	Unit	–	Default	60B9 0010 hex	Attribute	–		
Size	4 bytes (U32)		Access	RO	PDO map	Not possible			
Sub-index 07 hex		PDO entry 7 (7th Input Object to be mapped)							
Range	–	Unit	–	Default	60BA 0020 hex	Attribute	–		
Size	4 bytes (U32)		Access	RO	PDO map	Not possible			
Sub-index 08 hex		PDO entry 8 (8th Input Object to be mapped)							
Range	–	Unit	–	Default	60BC 0020 hex	Attribute	–		
Size	4 bytes (U32)		Access	RO	PDO map	Not possible			
Sub-index 09 hex		PDO entry 9 (9th Input Object to be mapped)							
Range	–	Unit	–	Default	60FD 0020 hex	Attribute	–		
Size	4 bytes (U32)		Access	RO	PDO map	Not possible			
Sub-index 0A hex		PDO entry 10 (10th Input Object to be mapped)							
Range	–	Unit	–	Default	606C 0020 hex	Attribute	–		
Size	4 bytes (U32)		Access	RO	PDO map	Not possible			

- This is the mapping for an application that uses different modes of operation.
- Touch probe status is available. Only one latch position is supported.
- The Velocity actual value (606C hex) is provided.

1BFF hex	512th transmit PDO Mapping						All
Sub-index 00 hex		Number of objects in this PDO					
Setting range	–	Unit	–	Default	01 hex	Attribute	–
Size	1 byte (U8)		Access	RO	PDO map	Not possible	
Sub-index 01 hex		PDO entry 1 (1st Input Object to be mapped)					
Setting range	–	Unit	–	Default	20020108 hex	Attribute	–
Size	4 byte (U32)		Access	RO	PDO map	Not possible	

- This object mapping is for notifying that the G5-series Servo Drive has detected an error.
- Sysmac Error Status (2002-01 hex) is mapped.
- If you are connecting the G5-series Servo Drive with an NJ501-1□00-series Machine Automation Controller, map this object to Sync Manager 3 PDO Assignment (1C13 hex). Sysmac Studio, by default, automatically maps this object to Sync Manager 3 PDO Assignment (1C13 hex).

A-1-10 Sync Manager Communication Objects

Objects 1C00 to 1C33 hex set how to use the EtherCAT communications memory.

1C00 hex	Sync Manager Communication Type						All
Sub-index 00 hex		Number of used Sync Manager channels					
Range	–	Unit	–	Default	04 hex	Attribute	–
Size	1 byte (U8)		Access	RO	PDO map	Not possible	
Sub-index 01 hex		Communication type Synch Manager 0					
Range	–	Unit	–	Default	01 hex	Attribute	–
Size	1 byte (U8)		Access	RO	PDO map	Not possible	
Sub-index 02 hex		Communication type Synch Manager 1					
Range	–	Unit	–	Default	02 hex	Attribute	–
Size	1 byte (U8)		Access	RO	PDO map	Not possible	
Sub-index 03 hex		Communication type Synch Manager 2					
Range	–	Unit	–	Default	03 hex	Attribute	–
Size	1 byte (U8)		Access	RO	PDO map	Not possible	
Sub-index 04 hex		Communication type Synch Manager 3					
Range	–	Unit	–	Default	04 hex	Attribute	–
Size	1 byte (U8)		Access	RO	PDO map	Not possible	

- The sync manager has the following settings.

- SM0: Mailbox receive (Master to Slave)
- SM1: Mailbox send (Slave to Master)
- SM2: Process data output (Master to Slave)
- SM3: Process data input (Slave to Master)

1C10 hex	Sync Manager 0 PDO Assignment							All
-----------------	-------------------------------	--	--	--	--	--	--	------------

Sub-index 00 hex		Number of assigned PDOs					
Range	–	Unit	–	Default	00 hex	Attribute	–
Size	1 byte (U8)		Access	RO	PDO map	Not possible	

- The PDO mapping used by this sync manager is given. Mailbox reception sync manager does not have PDOs.

1C11 hex	Sync Manager 1 PDO Assignment							All
-----------------	-------------------------------	--	--	--	--	--	--	------------

Sub-index 00 hex		Number of assigned PDOs					
Range	–	Unit	–	Default	00 hex	Attribute	–
Size	1 byte (U8)		Access	RO	PDO map	Not possible	

- The PDO mapping used by this sync manager is given. Mailbox reception sync manager does not have PDOs.

1C12 hex	Sync Manager 2 PDO Assignment							All
-----------------	-------------------------------	--	--	--	--	--	--	------------

Sub-index 00 hex		Number of assigned PDOs					
Range	–	Unit	–	Default	01 hex	Attribute	D
Size	1 byte (U8)		Access	RW	PDO map	Not possible	
Sub-index 01 hex		1st PDO Mapping Object Index of assigned PDO					
Range	0000 to FFFF hex	Unit	–	Default	1701 hex	Attribute	D
Size	2 bytes (U16)		Access	RW	PDO map	Not possible	
Sub-index 02 hex		2nd PDO Mapping Object Index of assigned PDO					
Range	0000 to FFFF hex	Unit	–	Default	0000 hex	Attribute	D
Size	2 bytes (U16)		Access	RW	PDO map	Not possible	

- The reception PDOs used by this sync manager are given.
- These object mappings can be changed only when the EtherCAT communications state is Pre-Operational (Pre-Op).
- Since the mappings you changed are not saved in EEPROM, you must specify objects each time you turn ON the power of the G5-series Servo Drive in order to use the mapping other than the default setting.
- If any of the following operations is attempted, an ABORT code for SDO mailbox communications will be returned.
 Writing when the EtherCAT communications state is other than Pre-Operational (Pre-Op)
 Writing to other than 1600 hex and 1701 to 1705 hex
 Data written to 1C13 hex is not between 1A00/1B01 hex and 1B04/1BFF hex

1C13 hex	Sync Manager 3 PDO Assignment						All
Sub-index 00 hex		Number of assigned PDOs					
Range	–	Unit	–	Default	01 hex	Attribute	D
Size	1 byte (U8)		Access	RO	PDO map	Not possible	
Sub-index 01 hex		1st PDO Mapping Object Index of assigned PDO					
Range	0000 to FFFF hex	Unit	–	Default	1B01 hex	Attribute	D
Size	2 bytes (U16)		Access	RW	PDO map	Not possible	
Sub-index 02 hex		2nd PDO Mapping Object Index of assigned PDO					
Range	0000 to FFFF hex	Unit	–	Default	0000 hex	Attribute	D
Size	2 bytes (U16)		Access	RW	PDO map	Not possible	

- The transmission PDOs used by this sync manager are given.
- These object mappings can be changed only when the EtherCAT communications state is Pre-Operational (Pre-Op).
- Since the mappings you changed are not saved in EEPROM, you must specify objects each time you turn ON the power of the G5-series Servo Drive in order to use the mapping other than the default setting.
- If any of the following operations is attempted, an ABORT code for SDO mailbox communications will be returned.

Writing when the EtherCAT communications state is other than Pre-Operational (Pre-Op)

Writing to other than 1A00 hex and 1B01 to 1B04 hex and 1BFF hex

1C32 hex		Sync Manager 2 Synchronization						All	
Sub-index 00 hex		Number of Synchronization Parameters							
Range	–	Unit	–	Default	20 hex	Attribute	–		
Size	1 byte (U8)		Access	RO	PDO map	Not possible			
Sub-index 01 hex		Synchronization Type							
Range	–	Unit	–	Default	0002 hex	Attribute	A		
Size	2 bytes (U16)		Access	RO	PDO map	Not possible			
Sub-index 02 hex		Cycle Time							
Range	–	Unit	–	Default	0000 0000 hex	Attribute	–		
Size	4 bytes (U32)		Access	RO	PDO map	Not possible			
Sub-index 04 hex		Synchronization Types supported							
Range	–	Unit	–	Default	0004 hex	Attribute	–		
Size	2 bytes (U16)		Access	RO	PDO map	Not possible			
Sub-index 05 hex		Minimum Cycle Time							
Range	–	Unit	–	Default	0000 4268 hex	Attribute	–		
Size	4 bytes (U32)		Access	RO	PDO map	Not possible			
Sub-index 06 hex		Calc and Copy Time							
Range	–	Unit	–	Default	0007 A120 hex	Attribute	–		
Size	4 bytes (U32)		Access	RO	PDO map	Not possible			
Sub-index 09 hex		Delay Time							
Range	–	Unit	–	Default	0000 0000 hex	Attribute	–		
Size	4 bytes (U32)		Access	RO	PDO map	Not possible			
Sub-index 20 hex		Sync Error							
Range	–	Unit	–	Default	0	Attribute	–		
Size	1 bit (BOOL)		Access	RO	PDO map	Not possible			

- The Synchronization Type indicates the synchronization mode of Sync Manager 2.
0002 hex: DC mode 0
- The Cycle Time indicates the sync 0 event cycle in nanoseconds.
- The Synchronization Types supported indicates the types of synchronization supported.
0004 hex: DC mode 0
- The Sync Error is 1 when there is a synchronization error.

1C33 hex		Sync Manager3 Synchronization						All	
Sub-index 00 hex		Number of Synchronization Parameters							
Range	–	Unit	–	Default	20 hex	Attribute	–		
Size	1 byte (U8)		Access	RO	PDO map	Not possible			
Sub-index 01 hex		Synchronization Type							
Range	–	Unit	–	Default	0002 hex	Attribute	A		
Size	2 bytes (U16)		Access	RO	PDO map	Not possible			
Sub-index 02 hex		Cycle Time							
Range	–	Unit	ns	Default	0000 0000 hex	Attribute	–		
Size	4 bytes (U32)		Access	RO	PDO map	Not possible			
Sub-index 04 hex		Synchronization Types supported							
Range	–	Unit	–	Default	0004 hex	Attribute	–		
Size	2 bytes (U16)		Access	RO	PDO map	Not possible			
Sub-index 05 hex		Minimum Cycle Time							
Range	–	Unit	ns	Default	0000 4268 hex	Attribute	–		
Size	4 bytes (U32)		Access	RO	PDO map	Not possible			
Sub-index 06 hex		Calc and Copy Time							
Range	–	Unit	ns	Default	0006 06F8 hex	Attribute	–		
Size	4 bytes (U32)		Access	RO	PDO map	Not possible			
Sub-index 09 hex		Delay Time							
Range	–	Unit	–	Default	0000 0000 hex	Attribute	–		
Size	4 bytes (U32)		Access	RO	PDO map	Not possible			
Sub-index 20 hex		Sync Error							
Range	–	Unit	–	Default	0	Attribute	–		
Size	1 bit (BOOL)		Access	RO	PDO map	Not possible			

- The Synchronization Type indicates the synchronization mode of Sync Manager 3.
0002 hex: DC mode 0
- The Cycle time indicates the sync 0 event cycle in nanoseconds.
- The Synchronization Types supported indicates the types of synchronization supported.
0004 hex: DC mode 0
- The Delay Time is not supported. It reads as 0000 0000 hex.
- The Sync Error is 1 when there is a synchronization error.

A-1-11 Manufacturer Specific Objects

This section describes objects specific to G5-series Servo Drives with built-in EtherCAT communications. G5-series Servo Drive parameters (Pn□□□) are allocated to objects 3000 to 3999 hex. Index 3□□□ hex corresponds to G5-series Servo Drive parameter Pn□□□. For example, object 3504 hex is the same as parameter Pn504.

For details on servo parameters, refer to *Chapter 9 Details on Servo Parameter Objects*.



Precautions for Correct Use

Pn□□□ uses decimal numbers but object 3 □□□ hex is a hexadecimal number.

2002 hex	Sysmac Error						<input type="text" value="All"/>	
Sub-index 00 hex	Number of entries							
Setting range	–	Unit	–	Default setting	02 hex	Attribute	–	
Size	1 byte (U8)		Access	RO	PDO map	Not possible		
Sub-index 01 hex	Sysmac Error Status							
Setting range	–	Unit	–	Default setting	00 hex	Attribute	–	
Size	1 byte (U8)		Access	RO	PDO map	Possible		
Sub-index 02 hex	Sysmac Error Status Clear							
Setting range	–	Unit	–	Default setting	00 hex	Attribute	A	
Size	1 byte (U8)		Access	RW	PDO map	Not possible		

- This object is used to monitor Sysmac error status and clear the errors.
- Sub-index 01 hex: Sysmac Error Status
 - This object notifies the Controller of an error on the G5 Servo Drive.
 - If you are connecting the G5-series Servo Drive with a Machine Automation Controller NJ-series (Model: NJ501-1□00), map this object to the PDO.
- Sub-index 02 hex: Sysmac Error Status Clear
 - This object enables a Sysmac Product controller to reset the error that has occurred in the G5-series Servo Drive.



Additional Information

Sysmac Studio, by default assign the sub-index 01 hex (Sysmac Error Status) automatically, because it is mapped in the 512th transmit PDO Mapping (1BFF hex).

2100 hex	Error History Clear						All
Range	0000 0000 to FFFF FFFF hex	Unit	–	Default	0000 0000 hex	Attribute	A
Size	4 bytes (U32)		Access	RW	PDO map	Not possible	

- This object clears the contents of Diagnosis history (10F3 hex).
- This function can be executed by writing 6c63 6861 hex using SDO mailbox communications.
- The error history is saved in the EEPROM. If there is a Control Power Supply Undervoltage Error (Error No. 11.0), you cannot make write access to the EEPROM. This means that the diagnosis history cannot be cleared.
- In the following cases, an ABORT code is returned.
 - Writing with CompleteAccess.
 - Writing a value other than 6c63 6861 hex.
 - Writing when there is a Control Power Supply Undervoltage Error (Error No. 11.0).

2200 hex	Communications Error Setting						All
Range	0 to 15	Unit	Times	Default	1	Attribute	C
Size	1 byte (U8)		Access	RW	PDO map	Not possible	

- This object sets the number of times which a communications error can occur consecutively before a Communications Synchronization Error (Error No. 83.3) is detected.
- It can be set to between 0 and 15. The detection value will be set to one value higher than the set value.



Precautions for Correct Use

When the default setting is 1, a Communications Synchronization Error (Error No. 83.3) is detected if a communications error occurs 2 consecutive times.

2201 hex	Sync Not Received Timeout Setting						All
Range	0 to 600	Unit	s	Default	0	Attribute	C
Size	2 bytes (U16)		Access	RO	PDO map	Not possible	

- Set a value for which Interruptions Error (Error No. 88.2) are detected. If the set value is 0, the detection time will be 120 seconds.

4000 hex	Statusword 1						All
Range	0000 to FFFF hex	Unit	–	Default	0000 hex	Attribute	–
Size	2 bytes (U16)		Access	RO	PDO map	Possible	

- This object gives the present state of the Servo Drive.

Bit Descriptions

Bit	Name	Symbol	Code	Description	Support in each mode		
					Position	Speed	Torque
0	Origin Position	ZPOINT	0	Outside origin range	○	○	○
			1	Within origin range			
1	Distribution Completed	DEN	0	Distributing	○	×	×
			1	Distribution Completed			
2	Zero Speed Detected	ZSP	0	Zero speed not detected	○	○	○
			1	Zero speed detected			
3	Torque Limit Applied	TLIMIT	0	Torque limit not applied	○	○	○
			1	Torque Limit Applied			
4	Speed Limit	VLIMIT	0	Speed limit not detected during torque control	×	×	○
			1	Speed limit detected during torque control			
5	Forward Software Limit	PSOT	0	Outside limit range	○	○	○
			1	Within limit range			
6	Reverse Software Limit	NSOT	0	Outside limit range	○	○	○
			1	Within limit range			
7	Speed Agreement	VCMP	0	No speed agreement during speed control	×	○	×
			1	Speed agreement during speed control			
8	Positioning Completed 2	INP2	0	Outside positioning proximity range during positioning control	○	×	×
			1	Within positioning proximity range during positioning control			
9	Servo Ready	CMDRDY	0	Commands cannot be accepted during processing	○	○	○
			1	Commands can be accepted			
10 to 15	Reserved	–	–	–	–	–	

- If an unsupported bit is read, the value will be undefined.
- Bit 0: Origin Position (ZPOINT)
This bit is 1 when Position actual value (6064 hex) is within the Origin Range (3803 hex) after homing is completed. In the absolute mode, homing is completed when the control power is turned ON or when the Config operation is completed.

- **Distribution Completed (DEN)**
This bit shows Distribution Completed (DEN) for the position command. DEN is 1 under the following conditions:
In csp mode
 - When the position command distribution amount before or after position command filtering is zero during the communications cycle.
 In hm mode
 - When the position command distribution amount before or after position command filtering is zero during the communications cycle when the NC built into the servo amplifier has completed command distribution up to the target position.
 - **Bit 2: Zero Speed Detected (ZSP)**
This bit shows Zero Speed (ZSPD).
ZSPD is 1 when the absolute velocity actual value is less than Zero Speed Detection (3434 hex).
 - **Bit 3: Torque Limit (TLIM)**
T_LIM is 1 during torque limit. T_LIM is 0 when the servo is OFF. The judgment conditions during torque limit can be changed in the Torque Limit Flag Output Setting (3703 hex).
3703 hex = 0: 1 at torque limit, including torque command value
3703 hex = 1: 1 at torque limit, excluding torque command value
 - **Bit 4: Speed Limit (VLIMIT)**
This bit shows Speed Limiting (VLIMIT). When the Speed Limit Selection (3317 hex) is 0, the speed is limited by the Speed Limit Value Setting (3321 hex). When the Speed Limit Selection (3317 hex) is 1, the speed is limited by the smaller of the Speed Limit Value Setting (3321 hex) and Max profile velocity (607F hex). VLIMIT is 1 when the speed is being limited.
- Note 1** The position error in encoder pulses can be set as the threshold value for the external output signal INP2 output from the Position Setting Unit Selection (3520 hex). However, this signal is always in command units. Therefore, there may be differences in the judgment conditions for INP2 and NEAR, i.e., when an electronic gear is set.
- 2 This bit is forced to 0 when Target velocity ignored (6041 hex, bit 12) = 0 during deceleration processing for the drive prohibition input. Refer to page A-56 for details.
- **Bit 5: Forward Software Limit (PSOT)**
 - **Bit 6: Reverse Software Limit (NSOT)**
PSOT is 1 when the Position actual value is greater than the set value of the Max position limit (607D hex, Sub-index: 02 hex).
NSOT is 1 when the Position actual value is less than the set value of the Min position limit (607D hex, Sub-index: 01 hex).
The value is 0 when the Software Position Limit Function is disabled (individual settings are possible in each direction with 3801 hex) and when homing is not attained.
 - **Bit 7: Speed Agreement (VCMP)**
This bit operates as the Speed Agreement (V_CMP). VCMP is 1 when the absolute value of the difference between the command speed before acceleration limit and the Velocity actual value is less than the Speed Conformity Detection Range (3435 hex).
- Note 1** The position error in encoder pulses can be set as the threshold value for the external output signal INP output from the Position Setting Unit Selection (3520 hex). However, this signal is always in command units. The set values of Positioning Completion Condition Selection (3432 hex) and Positioning Completed Hold Time (3433 hex) do not affect this signal. Therefore, there may be differences in the judgment conditions for INP and Target reached (6041 hex bit 10), i.e., when an electronic gear is set.
- 2 This bit is forced to 0 when Target velocity ignored (6041 hex, bit 12) = 0 during deceleration processing for the drive prohibition input.
- **Bit 8: Positioning Proximity (NEAR) (Only during position control)**
This bit operates as the Positioning Proximity (NEAR). NEAR will be 1 when the absolute value of the position error converted to command units is less than the Position Completion Range 2 (3442 hex) regardless of whether position command distribution is completed.

- Bit 9: Servo Ready (CMDRDY)
This bit indicates if command reception is possible (1) or not possible (0). When Servo Ready is 0, one of the following operations is being processed. It changes to 1 when all processing has been completed.
 - Writing to object using SDO mailbox communications.
 - Executing Config (4100 hex).
 - Resetting Warning/Error.
 - Executing Error History Clear (2100 hex).
 - Executing Backup parameter changed (10F0 hex, Sub: 02 hex).
 - Executing Save all parameters (1010 hex, Sub: 01 hex).
 - Executing Restore all default parameters (1011 hex, Sub: 01 hex).
 - Executing Absolute Encoder Setup (4102 hex).
 - From when a Servo ON command (Enable operation) is accepted until the Servo ON state is reached.
 - From when a Servo OFF command (Disable operation, Shutdown, or Disable Voltage) is accepted until the Servo OFF state is reached.

4001 hex	Sub Error Code						<input type="checkbox"/>
Range	0000 to FFFF hex	Unit	–	Default	0000 hex	Attribute	–
Size	2 bytes (U16)		Access	RO	PDO map	Possible	

- This object shows errors that have occurred in the Servo Drive.

4020 hex	Reference Position for CSP					<input type="checkbox"/>	<input type="checkbox"/>	<input type="checkbox"/>
Range	-2,147,483,648 to 2,147,483,647 hex	Unit	Command units	Default setting	0	Attribute	–	
Size	4 bytes (INT32)		Access	RO	PDO map	Possible		

- This object shows the reference position by which the G5-series Servo Drive is switched from Cyclic synchronous velocity mode or Cyclic synchronous torque mode to Cyclic synchronous position mode.
- The controller references this object as the first command position after switching the control mode.
- This objects shows the Following error actual value (60F4 hex) in the Cyclic synchronous position mode.
- If you map this object to the PDO when the communications cycle is set to 250/500 μs or when the electronic gear ratio is not 1:1, a Function Setting Error (Error No. 93.4) will occur.
- When switching to Cyclic synchronous position mode (csp), set the Target position (607A hex) so that the difference between the 607A hex and 4020 hex values equals the operation speed.
- Switch to csp during Constant-speed driving while ensuring that the gain before and after switching is kept at the same value.
Torque fluctuations may occur during switching in the following cases due to a large difference in the reference position value:
 - During acceleration/deceleration
 - During high-speed rotation
 - During transition in the operation of the first-order lag filter based on the Position Command Filter Time Constant (3222 hex)
 - During transition in the operation of the FIR filter based on the Position Command FIR Filter Time Constant (3818 hex)
 - During gain switching
 - When the position gain value is small
 - When the speed integral gain is disabled or retained

Note This object is supported for unit version 2.1 or later.

4100 hex	Config						All
Range	0000 0000 to FFFF FFFF hex	Unit	–	Default	0000 0000 hex	Attribute	A
Size	4 bytes (U32)		Access	RW	PDO map	Not possible	

- This object enables changing objects with data attribute C.
- This function can be executed by writing 666e 6f63 hex using SDO mailbox communications.
- The Servo will be forced OFF if Configuration is executed in the Servo ON state.
- The Servo Drive moves to a Fault state (Error No. 27.7) after this process is completed.
- In the following cases, an ABORT code is returned.

Writing with CompleteAccess.

Writing a value other than 666e 6f63 hex.

Writing when there is a Control Power Supply Undervoltage Error (Error No. 11.0).

4102 hex	Absolute Encoder Setup						All except full
Range	0000 0000 to FFFF FFFF hex	Unit	–	Default	0000 0000 hex	Attribute	A
Size	4 bytes (U32)		Access	RW	PDO map	Not possible	

- This object clears the multi-rotation counter of the absolute encoder.
- This function can be executed by writing 6a64 6165 hex using SDO mailbox communications.
- The Servo Drive moves to a Fault State (Error No. 27.7) after this process is completed. Cycle the control power supply to the Servo Drive.
- In the following cases, an ABORT code is returned.

Writing with CompleteAccess.

Writing a value other than 6a64 6165 hex.

Writing during semi-closed control when using an absolute encoder as an absolute encoder and the Servo is not OFF.

4103 hex	Coordinate System Setting Mode						All
Range	0000 to FFFF hex	Unit	–	Default	0	Attribute	B
Size	2 bytes (U16)		Access	RO	PDO map	Possible	

- Set the mode during coordinate system setting.

4104 hex	Coordinate System Setting Position						All
Range	–2,147,483,648 to 2,147,483,647 hex	Unit	Command units	Default	0	Attribute	B
Size	4 bytes (INT32)		Access	RO	PDO map	Possible	

- Set the position information during coordinate system setting.

4107 hex	Error Reset						All
Range	0000 0000 to FFFF FFFF hex	Unit	–	Default	0000 0000 hex	Attribute	A
Size	4 bytes (U32)		Access	RW	PDO map	Not possible	

- This object resets errors and warnings.
- This function can be executed by writing 7473 7274 hex using SDO mailbox communications.

- Write to this object only after removing the cause of the error or warning.
- In the following cases, an ABORT code is returned.

Writing with CompleteAccess.

Writing a value other than 7473 7274 hex.

A-1-12 Servo Drive Profile Object

This section describes the CiA402 drive profile supported by G5-series Servo Drives.

603F hex	Error code						All
Range	0000 to FFFF hex	Unit	–	Default	0000 hex	Attribute	–
Size	2 bytes (U16)		Access	RO	PDO map	Possible	

- This object gives the latest error code or warning code in the Servo Drive.
- The given error is from the manufacturer specific area FF00 to FFFF hex.
- The lower word of FF00 to FFFF hex gives the main number of the error.
- 4001 hex: Sub Error Code (4001 hex) gives the main number and sub number of the error.
- The main number and sub number are hexadecimal numbers but are combinations of 0 to 9.

Index	Name	Data types	Specifications
603F hex	Error code	U16	0000 hex: No error
			FF01 hex: Error main number 1
			FF02 hex: Error main number 2
			: :
			FF99 hex: Error main number 99
			FFA0 hex: Warning A0 hex
			: :
			FFA9 hex: Warning A9 hex
			FFB0 hex: Warning B0 hex
			FFB1 hex: Warning B1 hex
FFB2 hex: Warning B2 hex			
Others	Reserved		
4001 hex	Sub Error Code	U16	Upper 8 bits F0 to F9 hex: Sub numbers 0 to 9
			Lower 8 bits 00 to 99 hex: Main numbers 0 to 99

6040 hex	Controlword						All
Range	0000 to FFFF hex	Unit	–	Default	0000 hex	Attribute	A
Size	2 bytes (U16)		Access	RW	PDO map	Possible	

- This object controls the state machine of the Servo Drive.

Description of Set Values

Bit	Name	Description
0	Switch on	The state is controlled by these bits.
1	Enable voltage	Quick stop is not supported. The Quick stop bit is ignored even if set to 0. For details, refer to <i>Command Coding</i> on page A-3.
2	Quick stop	
3	Enable operation	
4 to 6	Operation mode specific	These bits are specific to the operation mode. They are not used in Cyclic synchronous position mode.
7	Fault reset	Errors and warnings are reset when this bit turns ON.
8	Halt	This bit is specific to the operating mode.*1
9	Operation mode specific	They are not used in Cyclic synchronous position mode.
10	Reserved	
11	P_CL	These bits switch the torque limit function. They are normally set to 0. For details, refer to Torque Limit Switching.
12	N_CL	
13 to 15	Manufacturer specific	These are manufacturer specific bits. Always keep them at 0.

*1 If this bit is set to 1 during the Homing mode (hm), the Servomotor stops according to the settings of the Halt option code (605D hex). This bit is ignored in other modes of operation.

6041 hex	Statusword						All
Range	0000 to FFFF hex	Unit	–	Default	0000 hex	Attribute	–
Size	2 bytes (U16)		Access	RO	PDO map	Possible	

- This object gives the present state of the Servo Drive.

Bit Descriptions

Bit	Name	Description
0	Ready to switch on	These bits give the state. For details, refer to <i>State Coding</i> on page A-4.
1	Switched on	
2	Operation enabled	
3	Fault	
4	Voltage enabled *1	
5	Quick Stop *2	
6	Switch on disabled	
7	Warning	This bit indicates that warning status exists. Operation continues without changing the status.
8	Manufacturer specific	These are manufacturer specific bits. This bit is not used by G5-series Servo Drives.
9	Remote	This bit indicates that the Servo Drive is being controlled by the Controlword. Changes to 1 (remote) after initialization has been completed. When 0 (local) is given, it indicates that the support software has the control right to the Servo Drive.

Bit	Name	Description
10	Target reached	This bit is 1 when homing is completed during the Homing mode. *3 For details, refer to <i>6-5 Homing Mode</i> . This bit is not used in other modes of operation.
11	Internal limit active	This bit indicates that the limit function is in effect. This bit becomes 1 when the limit function in the Servo Drive is activated. The limit function has four limits, the torque limit, speed limit, drive prohibition input, and software limit.
12	Target value ignored or Homing attained	These bits are specific to the operation mode. This bit is 0 when the Servo Drive could not move according to the host command while the Servo is ON or in csp mode, csv mode, or cst mode. This bit will not become 0 if there is an error. When the Target value ignored bit is 0, the target value is ignored and operation will follow the Servo Drive's internal command. Update the target position in the controller while monitoring items such as the Position actual value or other target values for operation when the Target Value Ignored bit changes to 1 and the target position is enabled. It becomes 0 in the following cases. <ul style="list-style-type: none"> • Between when the drive prohibition input (PLS/NLS) is input until when the Servomotor decelerates and stops when the Drive Prohibition Input Selection (3504 hex) is set to 0. • When a warning occurs for a mode of operation. • When a data setting warning (B0 hex) occurs while the mode of operation is being changed and instead of changing the mode of operation, the current mode of operation is retained. • When a drive prohibition direction command is received while in a drive prohibition state. • When there is a change in position command that exceeds the motor's maximum speed. This bit changes to 1 when the homing operation reaches its target while in the Homing mode (hm).
13	Following error	These bits are specific to the operation mode. The Following error (Error counter overflow) is indicated in Cyclic synchronous position mode. Position Error Counter Overflow is set to 1 when the Position actual value (6064 hex) exceeds the Following error window (6065 hex) that is set based on Position demand value (6062 hex). This bit changes to 1 when the homing operation is not completed successfully while in the Homing mode (hm).
14 and 15	Manufacturer specific	These are manufacturer specific bits. This bit is not used by G5-series Servo Drives.

*1 The Voltage enabled bit indicates that the main circuit power supply is ON when it is 1.
*2 Not applicable in Quick stop active state. This bit is 0 in a “Not ready to switch ON” state only. It is always 1 in all other cases.
*3 This bit will also change to 1 when the actual speed becomes less than 30 r/min after bit 8 (Halt) in Controlword (6040 hex) is set to 1 during operation in the Homing mode.

605B hex	Shutdown option code All						
Range	-5 to 0	Unit	-	Default	-1	Attribute	B
Size	2 bytes (INT16)		Access	RW	PDO map	Not possible	

- This object sets the operation of the G5-series Servo Drive during Shutdown (transition from the operation enable state to the ready to switch state).
 "During Shutdown" refers to the duration in which the G5-series Servo Drive decelerates and then stops after main circuit power OFF (Shutdown).

Description of Set Values

Set value	Decelerating ^{*1}		After stopping	
	Deceleration method	Error	Operation after stopping	Error
-5	Immediate Stop ^{*2} Immediate Stop Torque = 3511 hex	Clear ^{*3}	Free	Clear ^{*3}
-4	Immediate Stop ^{*2} Immediate Stop Torque = 3511 hex	Clear ^{*3}	Dynamic brake operation	Clear ^{*3}
-3	Dynamic brake operation	Clear ^{*3}	Free	Clear ^{*3}
-2	Free-run	Clear ^{*3}	Dynamic brake operation	Clear ^{*3}
-1	Dynamic brake operation	Clear ^{*3}	Dynamic brake operation	Clear ^{*3}
0	Free-run	Clear ^{*3}	Free	Clear ^{*3}

- *1 Decelerating is the time between when the motor is running and when the motor speed reaches 30 r/min or less. Once the motor reaches 30 r/min or less and moves to the after-stop status, subsequent operation is based on the after-stop status regardless of the motor speed.
- *2 "Immediate Stop" means that the Servomotor stops immediately by using controls while the servo is kept ON. The torque command value at this time is restricted by the Immediate Stop Torque (3511 hex).
- *3 When the error is cleared, a process which makes the Position demand value follow the Position actual value comes into effect. To operate in cyclic sync mode (csp) after the servo turns ON, reset the command coordinates in the host controller and then execute the operation. The motor may move suddenly.



Precautions for Correct Use

- Position control is forced into operation during deceleration and after the motor has stopped (main power supply OFF). The internal position command generation process is also forced to stop.
- If an error occurs while the main power supply is OFF, operation will follow the Fault reaction option code (605E hex).
- If the main power supply turns OFF while the Servo is ON and the Undervoltage Error Selection (3508 hex) is set to 1, a Main Power Supply Undervoltage (Error No. 13.1) will occur. Operation will then follow the Fault reaction option code (605E hex). The default value is 1.

605C hex	Disable operation option code						All
Range	-5 to 0	Unit	–	Default	-1	Attribute	B
Size	2 bytes (INT16)		Access	RW	PDO map	Not possible	

- This object sets the operation of the G5-series Servo Drive during Disable operation (transition from the operation enable state to the switched on state). "During Disable operation" refers to the duration in which the G5-series Servo Drive decelerates and then stops after Servo OFF (Disable operation).

Description of Set Values

Set value	Decelerating ^{*1}		After stopping	
	Deceleration method	Error	Operation after stopping	Error
-5	Immediate Stop ^{*2} Immediate Stop Torque = 3511 hex	Clear ^{*3}	Free	Clear ^{*3}
-4	Immediate Stop ^{*2} Immediate Stop Torque = 3511 hex	Clear ^{*3}	Dynamic brake operation	Clear ^{*3}
-3	Dynamic brake operation	Clear ^{*3}	Free	Clear ^{*3}
-2	Free-run	Clear ^{*3}	Dynamic brake operation	Clear ^{*3}
-1	Dynamic brake operation	Clear ^{*3}	Dynamic brake operation	Clear ^{*3}
0	Free-run	Clear ^{*3}	Free	Clear ^{*3}

- *1 Decelerating is the time between when the motor is running and when the motor speed reaches 30 r/min or less. Once the motor reaches 30 r/min or less and moves to the after-stop status, subsequent operation is based on the after-stop status regardless of the motor speed.
- *2 "Immediate Stop" means that the Servomotor stops immediately by using controls while the servo is kept ON. The torque command value at this time is restricted by the Immediate Stop Torque (3511 hex).
- *3 When the error is cleared, a process which makes the Position demand value follow the Position actual value comes into effect. To execute interpolation feeding commands after the servo turns ON, reset the command coordinates in the host controller before executing them. The motor may move suddenly.



Precautions for Correct Use

- Position control is forced into operation during deceleration and after the motor has stopped (during servo OFF). The internal position command generation process is also forced to stop.
- If an error occurs while the servo is OFF, operation will follow the Fault reaction option code (605E hex).
- If the main power supply turns OFF while the servo is OFF, the Shutdown option code (605B hex) will be followed.

605D hex	Halt option code						pp hm
Range	1 to 3	Unit	–	Default	1	Attribute	B
Size	2 bytes (INT16)		Access	RW	PDO map	Not possible	

- This object sets the stop method when bit 8 (Halt) in Controlword (6040 hex) is set to 1 during the Homing mode (hm).

Set value	Description
1	Profile deceleration (6084 hex)
2	Not supported
3	Immediate stop

605E hex	Fault reaction option code						All
Range	-7 to 0	Unit	-	Default	-1	Attribute	B
Size	2 bytes (INT16)		Access	RW	PDO map	Not possible	

- This object sets the behavior when an error occurs.

Description of Set Values

Set value	Decelerating ^{*1}		After stopping		
	Deceleration method		Error	Operation after stopping	Error
-7	Operation A ^{*2}	Immediate Stop ^{*2} Immediate Stop Torque = 3511 hex	Clear ^{*3}	Free	Clear ^{*3}
	Operation B ^{*2}	Free-run			
-6	Operation A ^{*2}	Immediate Stop ^{*2} Immediate Stop Torque = 3511 hex	Clear ^{*3}	Free	Clear ^{*3}
	Operation B ^{*2}	Dynamic brake operation			
-5	Operation A ^{*2}	Immediate Stop ^{*2} Immediate Stop Torque = 3511 hex	Clear ^{*3}	Dynamic brake operation	Clear ^{*3}
	Operation B ^{*2}	Free-run			
-4	Operation A ^{*2}	Immediate Stop ^{*2} Immediate Stop Torque = 3511 hex	Clear ^{*3}	Dynamic brake operation	Clear ^{*3}
	Operation B ^{*2}	Dynamic brake operation			
-3	Dynamic brake operation		Clear ^{*3}	Free	Clear ^{*3}
-2	Free-run		Clear ^{*3}	Dynamic brake operation	Clear ^{*3}
-1	Dynamic brake operation		Clear ^{*3}	Dynamic brake operation	Clear ^{*3}
0	Free-run		Clear ^{*3}	Free	Clear ^{*3}

- *1 Decelerating is the time between when the motor is running and when the motor speed reaches 30 r/min or less. Once the motor reaches 30 r/min or less and moves to the after-stop status, subsequent operation is based on the after-stop status regardless of the motor speed.
- *2 Operation A and B indicate whether or not to stop immediately when an error occurs. If this value is set to between 4 and 7, the motor is stopped immediately when a specified error occurs as indicated by operation A. If an error occurs that is not subject to this function, an immediate stop is not applied and dynamic braking is applied or the motor is left to run free as indicated by operation B. For details on errors, refer to *Errors* on page 12-9.
- *3 When the error is cleared, a process which makes the Position demand value follow the Position actual value comes into effect. To operate in cyclic sync mode (csp) after the servo turns ON, reset the command coordinates in the host controller and then execute the operation. The motor may move suddenly.



Precautions for Correct Use

Position control is forced into operation during deceleration and after the motor has stopped (during an error or when the servo is OFF). The internal position command generation process is also forced to stop.

6060 hex	Modes of operation						All
Range	0 to 10	Unit	–	Default	0	Attribute	A
Size	1 byte (INT8)		Access	RW	PDO map	Possible	

- This object sets the operation mode.
- The default value is 0 (Not specified). Set the operation mode from the master after the power supply is turned ON.
- A Command warning (Error No. B1 hex) occurs if the servo is turned ON (Operation enabled = 1) with the default setting of 0 (Not specified).
- Even when the default value (0: Not specified) is set again after changing the mode of operation, the mode of operation does not return to “Not specified.” The previous mode of operation is retained.
- Similarly, when an unsupported mode of operation is set, the previous mode is retained.
- When an unsupported mode of operation is set using SDO mailbox communications, an ABORT code is returned.

Description of Set Values

Code	Description
0	Not specified
1	Profile position mode (pp) ^{*1}
6	Homing mode (hm)
8	Cyclic synchronous position mode (csp)
9	Cyclic synchronous velocity mode (csv)
10	Cyclic synchronous torque mode (cst)

*1 Profile position mode (pp) is supported for unit version 2.1 or later.

For details about changing the modes of operation, refer to *A-1-5 Changing the Mode of Operation* on page A-7.

6061 hex	Modes of operation display						All
Range	0 to 10	Unit	–	Default	0	Attribute	–
Size	1 byte (INT8)		Access	RO	PDO map	Possible	

- This object gives the present operation mode.
- The value definitions are the same as for the Modes of operation (6060 hex).

6062 hex	Position demand value						csp pp hm
Range	–2,147,483,648 to 2,147,483,647	Unit	Command units	Default	0	Attribute	–
Size	4 bytes (INT32)		Access	RO	PDO map	Possible	

- This object gives the Servo Drive's internal command position.

6063 hex	Position actual internal value [All]						
Range	-2,147,483,648 to 2,147,483,647	Unit	Pulses	Default	0	Attribute	-
Size	4 bytes (INT32)		Access	RO	PDO map	Possible	

- This object gives the Servo Drive's present internal position.
- The value is in encoder units or external encoder units.
 - Other than fully-closed control : Encoder units
 - Fully-closed control : External encoder units

6064 hex	Position actual value [All]						
Range	-2,147,483,648 to 2,147,483,647	Unit	Command units	Default	0	Attribute	-
Size	4 bytes (INT32)		Access	RO	PDO map	Possible	

- This object gives the present position.

6065 hex	Following error window [csp] [pp] [hm]						
Range	0 to 134,217,728, 4,294,967,295	Unit	Command units	Default	100,000	Attribute	A
Size	4 bytes (U32)		Access	RW	PDO map	Not possible	

- This object sets the threshold for following errors.
- If it is set to 4,294,967,295 (FFFF FFFF hex), detection of following errors is disabled.
- If it is set to 0, there will always be a following error.
- When it is set to between 134,217,729 and 4,294,967,294, the set value becomes 134,217,728.

6067 hex	Position window [csp] [pp] [hm]						
Range	0 to 262,144	Unit	Command units	Default	10	Attribute	A
Size	4 bytes (U32)		Access	RW	PDO map	Not possible	

- Select the position error threshold at which the positioning completion signal (INP1) is output. The default unit is command units, but 3520 hex (Position Setting Unit Selection) can be used to convert to encoder units. If the unit is converted, the unit of 6065 hex (Following error window) will also be converted.
- This setting is also used for the Target reached flag in the EtherCAT communications status. The unit, however, is always command units regardless of the setting of 3520 hex.

606C hex	Velocity actual value [All]						
Range	-2,147,483,647 to 2,147,483,647	Unit	Command units/s	Default	0	Attribute	-
Size	4 bytes (U32)		Access	RO	PDO map	Possible	

- This object gives the present speed.

6071 hex	Target torque [cst]						
Range	-5,000 to 5,000	Unit	0.1%	Default	0	Attribute	A
Size	2 bytes (U16)		Access	RW	PDO map	Possible	

- This object sets the torque command in the Cyclic synchronous torque mode.

6072 hex	Max torque [All]						
Range	0 to 5,000	Unit	0.1%	Default	5,000	Attribute	A
Size	2 bytes (U16)		Access	RW	PDO map	Possible	

- This object sets the maximum torque.
- Set the value in units of 0.1% of the rated torque (100%).

6074 hex	Torque demand [All]						
Range	-5,000 to 5,000	Unit	0.1%	Default	0	Attribute	-
Size	2 bytes (INT16)		Access	RO	PDO map	Possible	

- This object gives the Servo Drive's internal torque command value.
- Set the value in units of 0.1% of the rated torque (100%).

6077 hex	Torque actual value [All]						
Range	-5,000 to 5,000	Unit	0.1%	Default	0	Attribute	-
Size	2 bytes (INT16)		Access	RO	PDO map	Possible	

- This object gives the feedback torque value. The values are the same as for the internal torque command value.
- Set the value in units of 0.1% of the rated torque (100%).

607A hex	Target position [csp] [pp]						
Range	-2,147,483,648 to 2,147,483,647	Unit	Command units	Default	0	Attribute	A
Size	4 bytes (INT32)		Access	RW	PDO map	Possible	

- This object sets the target position in the Cyclic synchronous position mode.

607C hex	Home offset [All]						
Range	-1,073,741,823 to 1,073,741,823	Unit	Command units	Default	0	Attribute	C
Size	4 bytes (INT32)		Access	RW	PDO map	Not possible	

- This object sets the amount of offset from the origin of the absolute encoder or absolute external encoder to the zero position of the Position actual value (6064 hex).

607D hex	Software position limit						All		
Sub-index 00 hex		Number of entries							
Range	–	Unit	–	Default	02 hex	Attribute	–		
Size	1 byte (U8)		Access	RO	PDO map	Not possible			
Sub-index 01 hex		Min position limit							
Range	–1,073,741,823 to 1,073,741,823	Unit	Command units	Default	–500,000	Attribute	A		
Size	4 bytes (INT32)		Access	RW	PDO map	Not possible			
Sub-index 02 hex		Max position limit							
Range	–1,073,741,823 to 1,073,741,823	Unit	Command units	Default	500,000	Attribute	A		
Size	4 bytes (INT32)		Access	RW	PDO map	Not possible			

- This object sets the software limit.
- Ranges for the Position demand value and Position actual value are restricted. New target positions are checked against these ranges.
- The software limit is always relative to the mechanical origin.
- The Min position limit is the limiting value for reverse rotation and the Max position limit is the limiting value for forward rotation.



Precautions for Correct Use

- Make sure that the Max position limit is larger than the Min position limit.
- The software position limit is disabled when an origin return has not been completed.

607F hex	Max profile velocity						cst	
Range	0 to 2,147,483,647	Unit	Command units/s	Default	0	Attribute	A	
Size	4 bytes (U32)		Access	RW	PDO map	Possible		

- This object sets the maximum velocity in the Cyclic synchronous torque mode.

6081h	Profile Velocity						pp	
Range	0 to 2,147,483,647	Unit	Command units/s	Default setting	0	Attribute	A	
Size	4 bytes (U32)		Access	RW	PDO map	Possible		

- This object sets the target velocity for Profile position mode (pp).

Note This object is supported for unit version 2.1 or later.

6083 hex	Profile acceleration [pp] [hm]						
Range	1 to 655,350,000	Unit	Command units/s ²	Default	1,000,000	Attribute	B
Size	4 bytes (U32)		Access	RW	PDO map	Not possible	

- This object sets the acceleration rate in the Cyclic synchronous torque mode (cst).
- The setting resolution is 4,000. For example, if you set 5,000, the resolution will be 4,000.

6084 hex	Profile deceleration [pp] [hm]						
Range	1 to 655,350,000	Unit	Command units/s ²	Default	1,000,000	Attribute	B
Size	4 bytes (U32)		Access	RW	PDO map	Not possible	

- This object sets the deceleration rate in the Cyclic synchronous torque mode (cst).
- The setting resolution is 4000. For example, if you set 5000, the resolution will be 4,000.

6086 hex	Motion profile type [csp] [pp] [hm]						
Range	-1 to 0	Unit	-	Default	0	Attribute	B
Size	2 bytes (INT16)		Access	RW	PDO map	Possible	

- This object enables and disables the position command FIR filter.
- When this object is set to -1, the value of Position Command FIR Filter Time Constant (3818 hex) is enabled.
- When this object is set to 0, the position command FIR filter is disabled.
- The position command FIR filter can be used in Cyclic synchronous position mode (csp), Profile position mode (pp), and Homing mode (hm).

Note Profile position mode (pp) is supported for unit version 2.1 or later.

- When the communications cycle is set to 250 μs or 500 μs, the position command FIR filter is disabled regardless of this setting.

6091 hex	Gear ratio						All
Sub-index 00 hex		Number of entries					
Range	–	Unit	–	Default	02 hex	Attribute	–
Size	1 byte (U8)		Access	RO	PDO map	Not possible	
Sub-index 01 hex		Motor revolutions					
Range	0 to 1,073,741,824	Unit	–	Default	1	Attribute	C
Size	4 bytes (U32)		Access	RW	PDO map	Not possible	
Sub-index 02 hex		Shaft revolutions					
Range	1 to 1,073,741,824	Unit	–	Default	1	Attribute	C
Size	4 bytes (U32)		Access	RW	PDO map	Not possible	

- These objects set the gear ratio.
- Set the numerator of the electronic gear in the object for sub-index 01h (Motor revolutions). If the set value is 0, the encoder resolution will be set as the numerator.
- Set the denominator of the electronic gear in the object for sub-index 02h (Shaft revolutions).
- Set the gear ratio to between 1/1,000 and 1,000. If the gear ratio is out of range, an Object Setting Error (Error No. 93.0) will occur.
- If the set value of Motor revolutions is 0, the encoder resolution will be set as the numerator, even for fully-closed control.
- If you are mapping the Reference Position for CSP (4020 hex) to the PDO, be sure to set the electronic gear ratio to 1:1. Unless set to 1:1, a Function Setting Error (Error No. 93.4) will occur.
- Refer to 7-6 *Electronic Gear Function* on page 7-21 for details.



Precautions for Correct Use

- The electronic gear function is not supported for unit version 2.0. Use the G-series Servo Drive in the setting of 1:1.

6098 hex	Homing method						hm
Range	-128 to 127	Unit	Command units/s ²	Default	0	Attribute	B
Size	1 byte (INT8)		Access	RW	PDO map	Not possible	

- This object sets the Homing method in the Homing mode (hm).

Explanation of Set Values

Set value	Explanation
0	Not specified
8	Homing by Origin Proximity Input and origin signal (forward operation start)
12	Homing by Origin Proximity Input and origin signal (reverse operation start)
19	Homing without origin signal (forward operation start)
20	Homing without origin signal (reverse operation start)
33	Homing with origin signal (reverse operation start)
34	Homing with origin signal (forward operation start)
35	Present home preset

- If the homing operation is started by setting a value other than 8, 12, 19, 20, 33, 34, or 35, a Command Error (Error No. 91.1) will occur.
- For details on homing, refer to *A-1-6 Homing Mode Specifications* on page A-15.

6099 hex	Homing speeds						hm
Sub-index 00 hex		Number of entries					
Range	-	Unit	-	Default	02 hex	Attribute	-
Size	1 byte (U8)		Access	RO	PDO map	Not possible	
Sub-index 01 hex		Speed during search for switch					
Range	100 to 3,276,700	Unit	Command units/s	Default	5,000	Attribute	B
Size	4 bytes (U32)		Access	RO	PDO map	Not possible	
Sub-index 02 hex		Speed during search for zero					
Range	100 to 3,276,700	Unit	Command units/s	Default	5,000	Attribute	B
Size	4 bytes (U32)		Access	RO	PDO map	Not possible	

- This object sets the homing speed.
- For Sub-index 01 hex (Speed during search for switch), set the operation speed during the homing operation from the start of the homing operation until the Origin Proximity Input turns ON.
- For Sub-index 02 hex (Speed during search for zero), set the operation speed during the homing operation from when the Origin Proximity Input turns ON until the latch signal is detected after the Origin Proximity Input again turns OFF.

60B0 hex	Position offset						<input type="checkbox"/> csp
Range	-2,147,483,648 to 2,147,483,647	Unit	Command units	Default	0	Attribute	A
Size	4 bytes (INT32)		Access	RW	PDO map	Possible	

- This object sets the position command offset.
- In Cyclic synchronous position mode (csp), the offset value is added to the Target position (607A hex) for use as the target position in controlling the position.
- Set the relationship between the Target position (607A hex) and Position offset (60B0 hex) so that the following expression is fulfilled. If the relational expression is not met, the operation may be performed in the direction opposite to the command increment direction.

$$\text{Absolute value of (Current position command additional value - Previous position command additional value)} \leq \text{Maximum motor speed} \leq 2,147,483,647$$

60B1 hex	Velocity offset						<input type="checkbox"/> csp <input type="checkbox"/> csv
Range	-2,147,483,648 to 2,147,483,647	Unit	Command units/s	Default	0	Attribute	A
Size	4 bytes (INT32)		Access	RW	PDO map	Possible	

- In Cyclic synchronous position mode (csp), the value of this object is added to the Speed Feed-forward Gain (3110 hex) for use as the speed feed-forward input value in controlling the speed.

60B2 hex	Torque offset						<input type="checkbox"/> csp <input type="checkbox"/> csv <input type="checkbox"/> cst
Range	-5,000 to 5,000	Unit	0.1%	Default	0	Attribute	A
Size	2 bytes (INT16)		Access	RW	PDO map	Possible	

- In Cyclic synchronous position mode (csp) or Cyclic synchronous velocity mode (csv), the value of this object is added to the Torque Feed-forward Gain (3112 hex) for use as the torque feed-forward input value in controlling the torque. In Cyclic synchronous torque mode (cst), the value of this object is used as the offset value of the Target torque (6071 hex) to control the torque.

60B8 hex	Touch probe function (Latch function)						All
Range	–	Unit	–	Default	0	Attribute	A
Size	2 bytes (U16)		Access	RW	PDO map	Possible	

- This object sets and controls the latch function.
- There are two channels, Latch 1 (bits 1 to 7) and Latch 2 (bits 8 to 15).
- Bits 0 and 8 execute latching when changed from 0 to 1.
- To change the settings, set bit 0 or 8 to 0 and then to 1 again.
- Latching is disabled in the following cases.
 - When communications is in the Init state.
 - When the Statusword (6041 hex) bit 9 (remote) is 0 (local).
- For details on the latch function, refer to *7-11 Touch Probe Function (Latch Function)* on page 7-40.

Bit Descriptions

Bit	Code	Description
0	0	Latch 1 is disabled.
	1	Latch 1 is enabled.
1	0	Trigger first event (Latch on the first trigger).
	1	Continuous (Latch continuously on trigger input).
2	0	Latch on the signal selected in the Touch Probe Trigger Selection (3758 hex).
	1	Latch on the encoder's phase-Z signal.
3 to 7	0	Reserved (always set to 0).
8	0	Latch 2 is disabled.
	1	Latch 2 is enabled.
9	0	Trigger first event (Latch on the first trigger).
	1	Continuous (Latch continuously on trigger input).
10	0	Latch on the signal selected in the Touch Probe Trigger Selection (3758 hex).
	1	Latch on the encoder's phase-Z signal.
11 to 15	0	Reserved (always set to 0).

60B9 hex	Touch probe status (Latch status)						All
Range	–	Unit	–	Default	0	Attribute	–
Size	2 bytes (U16)		Access	RO	PDO map	Possible	

- This object gives the status of the Touch probe function (Latch Function).

Bit Descriptions

Bit	Code	Description
0	0	Latch 1 is disabled.
	1	Latch 1 is enabled.
1	0	No value latched with Latch 1.
	1	There is a value latched with Latch 1.
2 to 5	0	Reserved (always set to 0).
6 and 7	0 to 3	The number of times latching is performed by Latch 1 in continuous latching. *1
8	0	Latch 2 is disabled.
	1	Latch 2 is enabled.
9	0	No value latched with Latch 2.
	1	There is a value latched with Latch 2.
10 to 13	0	Reserved (always set to 0).
14 to 15	0 to 3	The number of times latching is performed by Latch 2 in continuous latching. *1

*1 These bits cyclically indicate the number of times latching is performed between 0 and 3 when continuous latching is set (bits 1 or 9 of 60B8 hex is set to 1). They are cleared when bit 0 or 8 becomes 0.

60BA hex	Touch probe pos1 pos value						All
Range	–2,147,483,648 to 2,147,483,647	Unit	Command units	Default	0	Attribute	–
Size	4 bytes (INT32)		Access	RO	PDO map	Possible	

- This object gives the latch position for Latch 1.

60BC hex	Touch probe pos2 pos value						All
Range	–2,147,483,648 to 2,147,483,647	Unit	Command units	Default	0	Attribute	–
Size	4 bytes (INT32)		Access	RO	PDO map	Possible	

- This object gives the latch position for Latch 2.

60E0 hex	Positive torque limit value						All
Range	0 to 5,000	Unit	0.1%	Default	5,000	Attribute	A
Size	2 bytes (U16)		Access	RW	PDO map	Possible	

- This object sets the forward torque limit.
- It is limited by the maximum torque of the connected motor.
- For details refer to 7-7 *Torque Limit Switching* on page 7-24.
- Set the value in units of 0.1% of the rated torque (100%).

60E1 hex	Negative torque limit value						All
Range	0 to 5000	Unit	0.1%	Default	5000	Attribute	A
Size	2 bytes (U16)		Access	RW	PDO map	Possible	

- This object sets the reverse torque limit.
- It is limited by the maximum torque of the connected motor.
- For details refer to *Torque Limit Switching* on page 7-24.
- Set the value in units of 0.1% of the rated torque (100%).

60E3 hex	Supported homing method						hm
Sub-index 00 hex		Number of objects					
Range	–	Unit	–	Default	07 hex	Attribute	–
Size	1 byte (U8)		Access	RO	PDO map	Not possible	
Sub-index 01 hex		1st supported homing method					
Range	–	Unit	–	Default	08 hex	Attribute	–
Size	2 bytes (U16)		Access	RO	PDO map	Not possible	
Sub-index 02 hex		2nd supported homing method					
Range	–	Unit	–	Default	12 hex	Attribute	–
Size	2 bytes (U16)		Access	RO	PDO map	Not possible	
Sub-index 03 hex		3rd supported homing method					
Range	–	Unit	–	Default	19 hex	Attribute	–
Size	2 bytes (U16)		Access	RO	PDO map	Not possible	
Sub-index 04 hex		4th supported homing method					
Range	–	Unit	–	Default	20 hex	Attribute	–
Size	2 bytes (U16)		Access	RO	PDO map	Not possible	
Sub-index 05 hex		5th supported homing method					
Range	–	Unit	–	Default	33 hex	Attribute	–
Size	2 bytes (U16)		Access	RO	PDO map	Not possible	
Sub-index 06 hex		6th supported homing method					
Range	–	Unit	–	Default	34 hex	Attribute	–
Size	2 bytes (U16)		Access	RO	PDO map	Not possible	
Sub-index 07 hex		7th supported homing method					
Range	–	Unit	–	Default	35 hex	Attribute	–
Size	2 bytes (U16)		Access	RO	PDO map	Not possible	

- This object shows the supported Homing methods.

60F4 hex	Following error actual value						<input type="checkbox"/> csp	<input type="checkbox"/> pp	<input type="checkbox"/> hm
Range	-536,870,912 to 536,870,912	Unit	Command units	Default	0	Attribute	-		
Size	4 bytes (INT32)		Access	RO	PDO map	Possible			

- This object gives the amount of position error.

60FA hex	Control effort						<input type="checkbox"/> pp	<input type="checkbox"/> hm	<input type="checkbox"/> csp	<input type="checkbox"/> csv
Range	-1,073,741,823 to 1,073,741,823	Unit	Command units/s	Default	0	Attribute	-			
Size	4 bytes (INT32)		Access	RO	PDO map	Possible				

- This object shows the Velocity Demand Value for the Servo Drive.

60FC hex	Position demand internal value						<input type="checkbox"/> All
Range	-1,073,741,823 to 1,073,741,823	Unit	Encoder units	Default	0	Attribute	-
Size	4 bytes (INT32)		Access	RO	PDO map	Possible	

- This object shows the Position demand internal value.

60FD hex	Digital inputs						<input type="checkbox"/> All
Range	0000 0000h to FFFF FFFF hex	Unit	-	Default	0000 0000 hex	Attribute	-
Size	4 bytes (U32)		Access	RO	PDO map	Possible	

- The bits in this object give the signal status of functions allocated by servo parameters 3400 to 3407, 3410, and 3411 hex.
- The brake interlock output gives the output status when brake interlock is selected as the general-purpose output.
- EDM output status gives the status of the EDM output.

Bit Descriptions

Bit	Signal name	Symbol	Code	Description
0	Negative limit switch (Reverse Drive Prohibition Input)	NOT	0	OFF
			1	ON
1	Positive limit switch (Forward Drive Prohibition Input)	POT	0	OFF
			1	ON
2	Home switch (Origin Proximity Input)	DEC	0	OFF
			1	ON
3 to 15	Reserved	-	-	-
16	Encoder Phase Z Detection	PC	0	Phase-Z signal not detected during communication cycle
			1	Phase-Z signal detected during communication cycle
17	External Latch Input 1	EXT1	0	OFF
			1	ON
18	External Latch Input 2	EXT2	0	OFF
			1	ON

Bit	Signal name	Symbol	Code	Description
19	External Latch Input 3	EXT3	0	OFF
			1	ON
20	Monitor Input 0	MON0	0	OFF
			1	ON
21	Monitor Input 1	MON1	0	OFF
			1	ON
22	Monitor Input 2	MON2	0	OFF
			1	ON
23	Forward External Torque Limit Input	PCL	0	OFF
			1	ON
24	Reverse External Torque Limit Input	NCL	0	OFF
			1	ON
25	Immediate Stop Input	STOP	0	OFF
			1	ON
26	Brake Interlock Output	BKIR	0	Brake released
			1	Brake locked
27	Safety Input 1	SF1	0	OFF
			1	ON
28	Safety Input 2	SF2	0	OFF
			1	ON
29	EDM Output	EDM	0	OFF
			1	ON

- This object will be 0 if the brake interlock output (BKIR) is not assigned to a general-purpose output.

60FE hex	Digital outputs						All
Sub-index 00 hex		Number of entries					
Range	–	Unit	–	Default	02 hex	Attribute	–
Size	1 byte (U8)		Access	RO	PDO map	Not possible	
Sub-index 01 hex		Physical outputs					
Range	0000 0000 to FFFF FFFF hex	Unit	–	Default	0000 0000 hex	Attribute	A
Size	4 bytes (U32)		Access	RW	PDO map	Possible	
Sub-index 02 hex		Bit mask					
Range	0000 0000 to FFFF FFFF hex	Unit	–	Default	0000 0000 hex	Attribute	B
Size	4 bytes (U32)		Access	RW	PDO map	Not possible	

- The bits in the physical outputs of this object set the outputs of function signals allocated by servo parameters 3400 to 3407, 3410, and 3411 hex.
- The bit mask sets masks for the physical outputs.

Bit Descriptions for Sub-index 01 hex

Bit	Signal name	Symbol	Code	Description
0	Set brake (Brake Interlock Output) ^{*1}	BKIR	0	don't set brake
			1	set brake
1 to 15	Reserved	–	0	–
16	Remote Output 1	R-OUT1	0	OFF
			1	ON
17	Remote Output 2	R-OUT2	0	OFF
			1	ON
24	Gain Switching	G-SEL	0	Gain 1
			1	Gain 2
25	Reserved	–	0	–
26	Speed Loop P/PI Control	P/PI	0	PI control
			1	P control

- The gain can be switched when realtime autotuning is disabled and gain 2 is enabled.
- Speed loop P/PI control can be switched when realtime autotuning and gain 2 are disabled.
- Set all reserved bits to 0.

*1 This bit cannot be used for NJ501-1□00 and CJ1W-NC□8□.

Bit Descriptions for Sub-index 02 hex

Bit	Signal name	Symbol	Code	Description
0	Set brake Mask (Brake Interlock Output Mask)	BKIR	0	Set brake disable output
			1	Set brake enable output
1 to 15	Reserved	–	–	–
16	Remote Output 1 Mask	R-OUT1	0	R-OUT1 disable output
			1	R-OUT1 enable output
17	Remote Output 2 Mask	R-OUT2	0	R-OUT2 disable output
			1	R-OUT2 enable output
24	Gain Switching Mask	G-SEL	0	Switch setting disable
			1	Switch setting enable
25	Reserved	–	–	–
26	Speed Loop P/PI Control Mask	P/PI	0	Switch setting disable
			1	Switch setting enable

60FF hex	Target velocity						<input type="checkbox"/> All
Range	–2,147,483,647 to 2,147,483,647	Unit	Command units/s	Default	0	Attribute	A
Size	4 bytes (INT32)		Access	RO	PDO map	Possible	

- Set the command speed for the Cyclic synchronous velocity.

6402 hex	Motor type						<input type="checkbox"/> All
Range	–	Unit	–	Default	3	Attribute	–
Size	2 bytes (U16)		Access	RO	PDO map	Not possible	

- This object indicates the type of motor that is connected.
- It is always 3 (PM synchronous motor) for G5-series Servo Drives.

6502 hex	Supported drive modes						All
Range	–	Unit	–	Default	Refer to the description.	Attribute	–
Size	4 bytes (U32)		Access	RO	PDO map	Not possible	

- This object indicates the supported operation modes.

Bit Descriptions

Bit	Supported mode	Definition
0	pp (Profile position mode)	Refer to the default setting.
1	vl (Velocity mode)	0: Not supported
2	pv (Profile velocity mode)	0: Not supported
3	tq (Profile torque mode)	0: Not supported
4	Reserved	0
5	hm (Homing mode)	1: Supported
6	ip (Interpolated position mode)	0: Not supported
7	csp (Cyclic synchronous position mode)	1: Supported
8	csv (Cyclic synchronous velocity mode)	1: Supported
9	cst (Cyclic synchronous torque mode)	1: Supported
10 to 31	Reserved	0

- Default setting
The table below describes the default setting for each unit version.

Unit version	Default setting	Description
Ver. 2.0	000003A0 hex	Bit 0 is "0: Not supported." Profile position mode (pp) cannot be used.
Ver. 2.1	000003A1 hex	Bit 0 is "1: Supported." Profile position mode (pp) can be used.

A-2 Object List

- This section describes the profile that is used to control the Servo Drive.
- Some objects are enabled by turning the power supply OFF and then ON again. After changing these objects, turn OFF the power supply, confirm that the power supply indicator has gone OFF, and then turn ON the power supply again.
- See below for the data attributes.

- A: Always enabled
- B: Prohibited to change during motor rotation or commanding.
If it is changed during motor rotation or commanding, the reflection timing is unknown.
- C: Updated after the control power is reset, or after a Config command is executed via EtherCAT communications.
- D: Changeable only when the EtherCAT communications state is Pre-Operational (Pre-Op).
- R: Updated when the control power supply is reset.
It is not updated for a Config command via EtherCAT communications.
- RO: Read only

Index	Sub-Index	Name	Default setting	Setting range	Unit	Size	Data attribute	PDO map	Corresponding Pn number
1000 hex	00 hex	Device Type	0002 0192 hex	–	–	4 bytes (U32)	RO	Not possible.	–
1001 hex	00 hex	Error Register	0	–	–	1 byte (U8)	RO	Not possible.	–
1008 hex	00 hex	Manufacturer Device Name	R88D-KN□□□-ECT	–	–	20 bytes (VS)	RO	Not possible.	–
1009 hex	00 hex	Manufacturer Hardware Version	–	–	–	20 bytes (VS)	RO	Not possible.	–
100A hex	00 hex	Manufacturer Software Version	Contains a number indicating the Servo Drive software version.	–	–	20 bytes (VS)	RO	Not possible.	–
1010 hex		Store Parameters	–	–	–	–	–	–	–
	00 hex	Number of entries	01 hex	–	–	1 byte (U8)	RO	Not possible.	–
	01 hex	Save all parameters	0000 0001 hex	–	–	4 bytes (U32)	A	Not possible.	–
1011 hex		Restore Default Parameters	–	–	–	–	–	–	–
	00 hex	Number of entries	01 hex	–	–	1 byte (U8)	RO	Not possible.	–
	01 hex	Restore all default parameters	0000 0001 hex	–	–	4 bytes (U32)	B	Not possible.	–
1018 hex		Identity Object	–	–	–	–	–	–	–
	00 hex	Number of entries	04 hex	–	–	1 byte (U8)	RO	Not possible.	–
	01 hex	Vender ID	0000 0083 hex	–	–	4 bytes (U32)	RO	Not possible.	–
	02 hex	Product Code	Refer to the table for object 1018 hex on page A-28.	–	–	4 bytes (U32)	RO	Not possible.	–
	03 hex	Revision Number		–	–	4 bytes (U32)	RO	Not possible.	–
	04 hex	Serial Number		–	–	4 bytes (U32)	RO	Not possible.	–

Index	Sub-Index	Name	Default setting	Setting range	Unit	Size	Data attribute	PDO map	Corresponding Pn number
10F0 hex		Backup Parameters Mode	–	–	–	–	–	–	–
	00 hex	Number of entries	02 hex	–	–	1 byte (U8)	RO	Not possible.	–
	01 hex	Backup Parameter Checksum	–	–	–	4 bytes (U32)	RO	Not possible.	–
	02 hex	Backup Parameter Changed	0	–	–	1 bit (BOOL)	A	Not possible.	–
10F3 hex		Diagnosis History	–	–	–	–	–	–	–
	00 hex	Number of entries	13 hex	–	–	1 byte (U8)	RO	Not possible.	–
	01 hex	Maximum Messages	00 hex	–	00 to 0E hex	1 byte (U8)	RO	Not possible.	–
	02 hex	Newest Message	06 hex	–	06 to 13 hex	1 byte (U8)	RO	Not possible.	–
	05 hex	Flags	0000 hex	–	0000 to 0001 hex	2 bytes (U16)	A	Not possible.	–
	06 hex	Diagnosis Message 1	–	–	23 bytes (VS) ^{*1}	16 bytes (VS)	RO	Not possible.	–
	07 hex	Diagnosis Message 2	–	–	23 bytes (VS) ^{*1}	16 bytes (VS)	RO	Not possible.	–
	:	:	:	:	:	:	:	:	:
	13 hex	Diagnosis Message 14	–	–	23 bytes (VS) ^{*1}	16 bytes (VS)	RO	Not possible.	–
1600 hex ^{*2}		1st receive PDO Mapping	–	–	–	–	–	–	–
	00 hex	Number of objects in this PDO	03 hex	–	–	1 byte (U8)	D	Not possible.	–
	01 hex	1st Output Object to be mapped	6040 0010 hex	–	–	4 bytes (U32)	D	Not possible.	–
	02 hex	2nd Output Object to be mapped	607A 0020 hex	–	–	4 bytes (U32)	D	Not possible.	–
	03 hex	3rd Output Object to be mapped	60B8 0010 hex	–	–	4 bytes (U32)	D	Not possible.	–
	04 hex	4th Output Object to be mapped	0000 0000 hex	–	–	4 bytes (U32)	D	Not possible.	–
	05 hex	5th Output Object to be mapped	0000 0000 hex	–	–	4 bytes (U32)	D	Not possible.	–
	06 hex	6th Output Object to be mapped	0000 0000 hex	–	–	4 bytes (U32)	D	Not possible.	–
	07 hex	7th Output Object to be mapped	0000 0000 hex	–	–	4 bytes (U32)	D	Not possible.	–
	08 hex	8th Output Object to be mapped	0000 0000 hex	–	–	4 bytes (U32)	D	Not possible.	–
	09 hex	9th Output Object to be mapped	0000 0000 hex	–	–	4 bytes (U32)	D	Not possible.	–
	0A hex	10th Output Object to be mapped	0000 0000 hex	–	–	4 bytes (U32)	D	Not possible.	–

*1 The size for unit version 2.0 or earlier is 16 bytes (VS).

*2 1600 hex is supported for unit version 2.1 or later.

Index	Sub-Index	Name	Default setting	Setting range	Unit	Size	Data attribute	PDO map	Corresponding Pn number
1701 hex		258th receive PDO Mapping	–	–	–	–	–	–	–
	00 hex	Number of objects in this PDO	04 hex	–	–	1 byte (U8)	RO	Not possible.	–
	01 hex	1st Output Object to be mapped	6040 0010 hex	–	–	4 bytes (U32)	RO	Not possible.	–
	02 hex	2nd Output Object to be mapped	607A 0020 hex	–	–	4 bytes (U32)	RO	Not possible.	–
	03 hex	3rd Output Object to be mapped	60B8 0010 hex	–	–	4 bytes (U32)	RO	Not possible.	–
	04 hex	4th Output Object to be mapped	60FE 0120 hex	–	–	4 bytes (U32)	RO	Not possible.	–
1702 hex		259th receive PDO Mapping	–	–	–	–	–	–	–
	00 hex	Number of objects in this PDO	07 hex	–	–	1 byte (U8)	RO	Not possible.	–
	01 hex	1st Output Object to be mapped	6040 0010 hex	–	–	4 bytes (U32)	RO	Not possible.	–
	02 hex	2nd Output Object to be mapped	607A 0020 hex	–	–	4 bytes (U32)	RO	Not possible.	–
	03 hex	3rd Output Object to be mapped	60FF 0020 hex	–	–	4 bytes (U32)	RO	Not possible.	–
	04 hex	4th Output Object to be mapped	6071 0010 hex	–	–	4 bytes (U32)	RO	Not possible.	–
	05 hex	5th Output Object to be mapped	6060 0008 hex	–	–	4 bytes (U32)	RO	Not possible.	–
	06 hex	6th Output Object to be mapped	60B8 0010 hex	–	–	4 bytes (U32)	RO	Not possible.	–
07 hex	7th Output Object to be mapped	607F 0020 hex	–	–	4 bytes (U32)	RO	Not possible.	–	
1703 hex		260th receive PDO Mapping	–	–	–	–	–	–	–
	00 hex	Number of objects in this PDO	07 hex	–	–	1 byte (U8)	RO	Not possible.	–
	01 hex	1st Output Object to be mapped	6040 0010 hex	–	–	4 bytes (U32)	RO	Not possible.	–
	02 hex	2nd Output Object to be mapped	607A 0020 hex	–	–	4 bytes (U32)	RO	Not possible.	–
	03 hex	3rd Output Object to be mapped	60FF 0020 hex	–	–	4 bytes (U32)	RO	Not possible.	–
	04 hex	4th Output Object to be mapped	6060 0008 hex	–	–	4 bytes (U32)	RO	Not possible.	–
	05 hex	5th Output Object to be mapped	60B8 0010 hex	–	–	4 bytes (U32)	RO	Not possible.	–
	06 hex	6th Output Object to be mapped	60E0 0010 hex	–	–	4 bytes (U32)	RO	Not possible.	–
07 hex	7th Output Object to be mapped	60E1 0010 hex	–	–	4 bytes (U32)	RO	Not possible.	–	

Index	Sub-Index	Name	Default setting	Setting range	Unit	Size	Data attribute	PDO map	Corresponding Pn number
1704 hex		261th receive PDO Mapping	–	–	–	–	–	–	–
	00 hex	Number of objects in this PDO	09 hex	–	–	1 byte (U8)	RO	Not possible.	–
	01 hex	1st Output Object to be mapped	6040 0010 hex	–	–	4 bytes (U32)	RO	Not possible.	–
	02 hex	2nd Output Object to be mapped	607A 0020 hex	–	–	4 bytes (U32)	RO	Not possible.	–
	03 hex	3rd Output Object to be mapped	60FF 0020 hex	–	–	4 bytes (U32)	RO	Not possible.	–
	04 hex	4th Output Object to be mapped	6071 0010 hex	–	–	4 bytes (U32)	RO	Not possible.	–
	05 hex	5th Output Object to be mapped	6060 0008 hex	–	–	4 bytes (U32)	RO	Not possible.	–
	06 hex	6th Output Object to be mapped	60B8 0010 hex	–	–	4 bytes (U32)	RO	Not possible.	–
	07 hex	7th Output Object to be mapped	607F 0020 hex	–	–	4 bytes (U32)	RO	Not possible.	–
	08 hex	8th Output Object to be mapped	60E0 0010 hex	–	–	4 bytes (U32)	RO	Not possible.	–
	09 hex	9th Output Object to be mapped	60E1 0010 hex	–	–	4 bytes (U32)	RO	Not possible.	–
1705 hex		262th receive PDO Mapping	–	–	–	–	–	–	–
	00 hex	Number of objects in this PDO	08 hex	–	–	1 byte (U8)	RO	Not possible.	–
	01 hex	1st Output Object to be mapped	6040 0010 hex	–	–	4 bytes (U32)	RO	Not possible.	–
	02 hex	2nd Output Object to be mapped	607A 0020 hex	–	–	4 bytes (U32)	RO	Not possible.	–
	03 hex	3rd Output Object to be mapped	60FF 0020 hex	–	–	4 bytes (U32)	RO	Not possible.	–
	04 hex	4th Output Object to be mapped	6060 0008 hex	–	–	4 bytes (U32)	RO	Not possible.	–
	05 hex	5th Output Object to be mapped	60B8 0010 hex	–	–	4 bytes (U32)	RO	Not possible.	–
	06 hex	6th Output Object to be mapped	60E0 0010 hex	–	–	4 bytes (U32)	RO	Not possible.	–
	07 hex	7th Output Object to be mapped	60E1 0010 hex	–	–	4 bytes (U32)	RO	Not possible.	–
	08 hex	8th Output Object to be mapped	60B2 0010 hex	–	–	4 bytes (U32)	RO	Not possible.	–

Index	Sub-Index	Name	Default setting	Setting range	Unit	Size	Data attribute	PDO map	Corresponding Pn number
1A00 hex *1		1st transmit PDO Mapping	–	–	–	–	–	–	–
	00 hex	Number of objects in this PDO	07 hex	–	–	1 byte (U8)	D	Not possible.	–
	01 hex	1st Input Object to be mapped	6041 0010 hex	–	–	4 bytes (U32)	D	Not possible.	–
	02 hex	2nd Input Object to be mapped	6064 0020 hex	–	–	4 bytes (U32)	D	Not possible.	–
	03 hex	3rd Input Object to be mapped	60B9 0010 hex	–	–	4 bytes (U32)	D	Not possible.	–
	04 hex	4th Input Object to be mapped	60BA 0020 hex	–	–	4 bytes (U32)	D	Not possible.	–
	05 hex	5th Input Object to be mapped	60BC 0020 hex	–	–	4 bytes (U32)	D	Not possible.	–
	06 hex	6th Input Object to be mapped	603F 0010 hex	–	–	4 bytes (U32)	D	Not possible.	–
	07 hex	7th Input Object to be mapped	60FD 0020 hex	–	–	4 bytes (U32)	D	Not possible.	–
	08 hex	8th Input Object to be mapped	0000 0000 hex	–	–	4 bytes (U32)	D	Not possible.	–
	09 hex	9th Input Object to be mapped	0000 0000 hex	–	–	4 bytes (U32)	D	Not possible.	–
	0A hex	10th Input Object to be mapped	0000 0000 hex	–	–	4 bytes (U32)	D	Not possible.	–
1B01 hex		258th transmit PDO Mapping	–	–	–	–	–	–	–
	00 hex	Number of objects in this PDO	09 hex	–	–	1 byte (U8)	RO	Not possible.	–
	01 hex	1st Input Object to be mapped	603F 0010 hex	–	–	4 bytes (U32)	RO	Not possible.	–
	02 hex	2nd Input Object to be mapped	6041 0010 hex	–	–	4 bytes (U32)	RO	Not possible.	–
	03 hex	3rd Input Object to be mapped	6064 0020 hex	–	–	4 bytes (U32)	RO	Not possible.	–
	04 hex	4th Input Object to be mapped	6077 0010 hex	–	–	4 bytes (U32)	RO	Not possible.	–
	05 hex	5th Input Object to be mapped	60F4 0020 hex	–	–	4 bytes (U32)	RO	Not possible.	–
	06 hex	6th Input Object to be mapped	60B9 0010 hex	–	–	4 bytes (U32)	RO	Not possible.	–
	07 hex	7th Input Object to be mapped	60BA 0020 hex	–	–	4 bytes (U32)	RO	Not possible.	–
	08 hex	8th Input Object to be mapped	60BC 0020 hex	–	–	4 bytes (U32)	RO	Not possible.	–
	09 hex	9th Input Object to be mapped	60FD 0020 hex	–	–	4 bytes (U32)	RO	Not possible.	–

*1 1A00 hex is supported for unit version 2.1 or later.

Index	Sub-Index	Name	Default setting	Setting range	Unit	Size	Data attribute	PDO map	Corresponding Pn number
1B02 hex		259th transmit PDO Mapping	–	–	–	–	–	–	–
	00 hex	Number of objects in this PDO	09 hex	–	–	1 byte (U8)	RO	Not possible.	–
	01 hex	1st Input Object to be mapped	603F 0010 hex	–	–	4 bytes (U32)	RO	Not possible.	–
	02 hex	2nd Input Object to be mapped	6041 0010 hex	–	–	4 bytes (U32)	RO	Not possible.	–
	03 hex	3rd Input Object to be mapped	6064 0020 hex	–	–	4 bytes (U32)	RO	Not possible.	–
	04 hex	4th Input Object to be mapped	6077 0010 hex	–	–	4 bytes (U32)	RO	Not possible.	–
	05 hex	5th Input Object to be mapped	6061 0008 hex	–	–	4 bytes (U32)	RO	Not possible.	–
	06 hex	6th Input Object to be mapped	60B9 0010 hex	–	–	4 bytes (U32)	RO	Not possible.	–
	07 hex	7th Input Object to be mapped	60BA 0020 hex	–	–	4 bytes (U32)	RO	Not possible.	–
	08 hex	8th Input Object to be mapped	60BC 0020 hex	–	–	4 bytes (U32)	RO	Not possible.	–
	09 hex	9th Input Object to be mapped	60FD 0020 hex	–	–	4 bytes (U32)	RO	Not possible.	–
1B03 hex		260th transmit PDO Mapping	–	–	–	–	–	–	–
	00 hex	Number of objects in this PDO	0A hex	–	–	1 byte (U8)	RO	Not possible.	–
	01 hex	1st Input Object to be mapped	603F 0010 hex	–	–	4 bytes (U32)	RO	Not possible.	–
	02 hex	2nd Input Object to be mapped	6041 0010 hex	–	–	4 bytes (U32)	RO	Not possible.	–
	03 hex	3rd Input Object to be mapped	6064 0020 hex	–	–	4 bytes (U32)	RO	Not possible.	–
	04 hex	4th Input Object to be mapped	6077 0010 hex	–	–	4 bytes (U32)	RO	Not possible.	–
	05 hex	5th Input Object to be mapped	60F4 0020 hex	–	–	4 bytes (U32)	RO	Not possible.	–
	06 hex	6th Input Object to be mapped	6061 0008 hex	–	–	4 bytes (U32)	RO	Not possible.	–
	07 hex	7th Input Object to be mapped	60B9 0010 hex	–	–	4 bytes (U32)	RO	Not possible.	–
	08 hex	8th Input Object to be mapped	60BA 0020 hex	–	–	4 bytes (U32)	RO	Not possible.	–
	09 hex	9th Input Object to be mapped	60BC 0020 hex	–	–	4 bytes (U32)	RO	Not possible.	–
	0A hex	10th Input Object to be mapped	60FD 0020 hex	–	–	4 bytes (U32)	RO	Not possible.	–

Index	Sub-Index	Name	Default setting	Setting range	Unit	Size	Data attribute	PDO map	Corresponding Pn number
1B04 hex		261th transmit PDO Mapping	–	–	–	–	–	–	–
	00 hex	Number of objects in this PDO	0A hex	–	–	1 byte (U8)	RO	Not possible.	–
	01 hex	1st Input Object to be mapped	603F 0010 hex	–	–	4 bytes (U32)	RO	Not possible.	–
	02 hex	2nd Input Object to be mapped	6041 0010 hex	–	–	4 bytes (U32)	RO	Not possible.	–
	03 hex	3rd Input Object to be mapped	6064 0020 hex	–	–	4 bytes (U32)	RO	Not possible.	–
	04 hex	4th Input Object to be mapped	6077 0010 hex	–	–	4 bytes (U32)	RO	Not possible.	–
	05 hex	5th Input Object to be mapped	6061 0008 hex	–	–	4 bytes (U32)	RO	Not possible.	–
	06 hex	6th Input Object to be mapped	60B9 0010 hex	–	–	4 bytes (U32)	RO	Not possible.	–
	07 hex	7th Input Object to be mapped	60BA 0020 hex	–	–	4 bytes (U32)	RO	Not possible.	–
	08 hex	8th Input Object to be mapped	60BC 0020 hex	–	–	4 bytes (U32)	RO	Not possible.	–
	09 hex	9th Input Object to be mapped	60FD 0020 hex	–	–	4 bytes (U32)	RO	Not possible.	–
0A hex	10th Input Object to be mapped	606C 0020 hex	–	–	4 bytes (U32)	RO	Not possible.	–	
1BFF hex *1		512th transmit PDO Mapping	–	–	–	–	–	–	–
	00 hex	Number of objects in this PDO	01 hex	–	–	1 byte (U8)	RO	Not possible.	–
	01 hex	1st Input Object to be mapped	2002 0108 hex	–	–	4 bytes (U32)	RO	Not possible.	–
1C00 hex		Sync Manager Communication Type	–	–	–	–	–	–	–
	00 hex	Number of used sync manager channels	04 hex	–	–	1 byte (U8)	RO	Not possible.	–
	01 hex	Communication type Sync Manager 0	01 hex	–	–	1 byte (U8)	RO	Not possible.	–
	02 hex	Communication type Sync Manager 1	02 hex	–	–	1 byte (U8)	RO	Not possible.	–
	03 hex	Communication type Sync Manager 2	03 hex	–	–	1 byte (U8)	RO	Not possible.	–
	04 hex	Communication type Sync Manager 3	04 hex	–	–	1 byte (U8)	RO	Not possible.	–
1C10 hex		Sync Manager 0 PDO Assignment	–	–	–	–	–	–	–
	00 hex	Number of assigned PDOs	00 hex	–	–	1 byte (U8)	RO	Not possible.	–
1C11 hex		Sync Manager 1 PDO Assignment	–	–	–	–	–	–	–
	00 hex	Number of Assigned PDOs	00 hex	–	–	1 byte (U8)	RO	Not possible.	–
1C12 hex		Sync Manager 2 PDO Assignment	–	–	–	–	–	–	–
	00 hex	Number of Assigned RxPDOs	01 hex	–	–	1 byte (U8)	D	Not possible.	–
	01 hex	1st PDO Mapping Object Index of assigned PDO	1701 hex	0000 to FFFF hex	–	2 bytes (U16)	D	Not possible.	–
	02 hex	2nd PDO Mapping Object Index of assigned PDO *2	0000 hex	0000 to FFFF hex	–	2 bytes (U16)	D	Not possible.	–

*1 1BFF hex is supported for unit version 2.1 or later.

*2 The Sync manager 2 PDO assignment (1C12-02 hex) and Sync manager 2 PDO assignment (1C13-02 hex) are supported for unit version 2.1 or later.

Index	Sub-Index	Name	Default setting	Setting range	Unit	Size	Data attribute	PDO map	Corresponding Pn number
1C13 hex		Sync Manager 3 PDO Assignment	-	-	-	-	-	-	-
	00 hex	Number of assigned TxPDOs	01 hex	-	-	1 byte (U8)	D	Not possible.	-
	01 hex	1st PDO Mapping Object Index of assigned PDO	1B01 hex	0000 to FFFF hex	-	2 bytes (U16)	D	Not possible.	-
	02 hex	2nd PDO Mapping Object Index of assigned PDO *2	0000 hex	0000 to FFFF hex	-	2 bytes (U16)	D	Not possible.	-
1C32 hex		Sync Manager 2 synchronization	-	-	-	-	-	-	-
	00 hex	Number of Synchronization Parameters	20 hex	-	-	1 byte (U8)	RO	Not possible.	-
	01 hex	Synchronization Type	0002 hex	-	-	2 bytes (U16)	RO	Not possible.	-
	02 hex	Cycle Time	0000 0000 hex	-	ns	4 bytes (U32)	RO	Not possible.	-
	04 hex	Synchronization Types supported	0004 hex	-	-	2 bytes (U16)	RO	Not possible.	-
	05 hex	Minimum Cycle Time	0000 4268 hex	-	ns	4 bytes (U32)	RO	Not possible.	-
	06 hex	Calc and Copy Time	0007 A120 hex	-	ns	4 bytes (U32)	RO	Not possible.	-
	09 hex	Delay Time	0000 0000 hex	-	ns	4 bytes (U32)	RO	Not possible.	-
	20 hex	Sync Error	0	-	-	1 bit (BOOL)	RO	TxPDO	-
1C33 hex		Sync Manager 3 synchronization	-	-	-	-	-	-	-
	00 hex	Number of Synchronization Parameters	20 hex	-	-	1 byte (U8)	RO	Not possible.	-
	01 hex	Synchronization Type	0002 hex	-	-	2 bytes (U16)	-	Not possible.	-
	02 hex	Cycle Time	0000 0000 hex	-	ns	4 bytes (U32)	RO	Not possible.	-
	04 hex	Synchronization Types supported	0004 hex	-	-	2 bytes (U16)	RO	Not possible.	-
	05 hex	Minimum Cycle Time	0000 4268 hex	-	ns	4 bytes (U32)	RO	Not possible.	-
	06 hex	Calc and Copy Time	0006 06F8 hex	-	ns	4 bytes (U32)	RO	Not possible.	-
	09 hex	Delay Time	0000 0000 hex	-	ns	4 bytes (U32)	RO	Not possible.	-
	20 hex	Sync Error	0	-	-	1 bit (BOOL)	RO	TxPDO	-
2002 hex *1		Sysmac Error	-	-	-	-	-	-	-
	00 hex	Number of entries	02 hex	-	-	1 byte (U8)	RO	Not possible.	-
	01 hex	Sysmac Error Status	00 hex	-	-	1 byte (U8)	RO	TxPDO	-
	02 hex	Sysmac Error Status Clear	00 hex	-	-	1 byte (U8)	A	Not possible.	-
2100 hex	00 hex	Error History Clear	0000 0000 hex	0 to 15	-	4 bytes (U32)	A	Not possible.	-
2200 hex	00 hex	Communications Error Setting	1	00 to 0F hex	Times	1 byte (U8)	C	Not possible.	Pn776

*1 2002 hex is supported for unit version 2.1 or later.

*2 The Sync manager 2 PDO assignment (1C12-02 hex) and Sync manager 2 PDO assignment (1C13-02 hex) are supported for unit version 2.1 or later.

Index	Sub-Index	Name	Default setting	Setting range	Unit	Size	Data attribute	PDO map	Corresponding Pn number
2201 hex	00 hex	Sync Not Received Timeout Setting	0	0 to 600	s	2 bytes (U16)	C	Not possible.	Pn777
3000 hex	00 hex	Rotation Direction Switching	1	0 to 1	–	2 bytes (INT16)	C	Not possible.	Pn000
3001 hex	00 hex	Control Mode Selection	0	0 to 6	–	2 bytes (INT16)	R	Not possible.	Pn001
3002 hex	00 hex	Realtime Autotuning Mode Selection	1	0 to 6	–	2 bytes (INT16)	B	Not possible.	Pn002
3003 hex	00 hex	Realtime Autotuning Machine Rigidity Setting	11/13 ^{*1}	0 to 31	–	2 bytes (INT16)	B	Not possible.	Pn003
3004 hex	00 hex	Inertia Ratio	250	0 to 10000	%	2 bytes (INT16)	B	Not possible.	Pn004
3013 hex	00 hex	External Torque Limit 1	5000	0 to 5000	0.1%	2 bytes (INT16)	B	Not possible.	Pn753
3015 hex	00 hex	Operation Switch when Using Absolute Encoder	2	0 to 2	–	2 bytes (INT16)	C	Not possible.	Pn015
3016 hex	00 hex	Regeneration Resistor Selection	0/3 ^{*2}	0 to 3	–	2 bytes (INT16)	C	Not possible.	Pn016
3017 hex	00 hex	External Regeneration Resistor Setting	0	0 to 4	–	2 bytes (INT16)	C	Not possible.	Pn017
3100 hex	00 hex	Position Loop Gain 1	320/480 ^{*3}	0 to 30000	0.1/s	2 bytes (INT16)	B	Not possible.	Pn100
3101 hex	00 hex	Speed Loop Gain 1	180/270 ^{*4}	1 to 32767	0.1 Hz	2 bytes (INT16)	B	Not possible.	Pn101
3102 hex	00 hex	Speed Loop Integral Time Constant 1	210/310 ^{*5}	1 to 10000	0.1 ms	2 bytes (INT16)	B	Not possible.	Pn102
3103 hex	00 hex	Speed Feedback Filter Time Constant 1	0	0 to 5	–	2 bytes (INT16)	B	Not possible.	Pn103
3104 hex	00 hex	Torque Command Filter Time Constant 1	84/126 ^{*6}	0 to 2500	0.01 ms	2 bytes (INT16)	B	Not possible.	Pn104
3105 hex	00 hex	Position Loop Gain 2	380/570 ^{*7}	0 to 30000	0.1 Hz	2 bytes (INT16)	B	Not possible.	Pn105
3106 hex	00 hex	Speed Loop Gain 2	180/270 ^{*8}	1 to 32767	0.1 Hz	2 bytes (INT16)	B	Not possible.	Pn106
3107 hex	00 hex	Speed Loop Integral Time Constant 2	10000	1 to 10000	0.1 ms	2 bytes (INT16)	B	Not possible.	Pn107
3108 hex	00 hex	Speed Feedback Filter Time Constant 2	0	0 to 5	–	2 bytes (INT16)	B	Not possible.	Pn108
3109 hex	00 hex	Torque Command Filter Time Constant 2	84/126 ^{*9}	0 to 2500	0.01 ms	2 bytes (INT16)	B	Not possible.	Pn109

- *1 The default setting is 11 for a Drive for 200 V and 1 kW or greater, or for a Drive for 400 V. It is set to 13 for other Drives.
- *2 The default setting is 0 for a Drive for 100 V and 400 W, for 200 V and 750 W or greater, or for a Drive for 400 V. It is set to 3 for other Drives.
- *3 The default setting is 320 for a Drive for 200 V and 1 kW or greater, or for a Drive for 400 V. It is set to 480 for other Drives.
- *4 The default setting is 180 for a Drive for 200 V and 1 kW or greater, or for a Drive for 400 V. It is set to 270 for other Drives.
- *5 The default setting is 310 for a Drive for 200 V and 1 kW or greater, or for a Drive for 400 V. It is set to 210 for other Drives.
- *6 The default setting is 126 for a Drive for 200 V and 1 kW or greater, or for a Drive for 400 V. It is set to 84 for other Drives.
- *7 The default setting is 380 for a Drive for 200 V and 1 kW or greater, or for a Drive for 400 V. It is set to 570 for other Drives.
- *8 The default setting is 180 for a Drive for 200 V and 1 kW or greater, or for a Drive for 400 V. It is set to 270 for other Drives.
- *9 The default setting is 126 for a Drive for 200 V and 1 kW or greater, or for a Drive for 400 V. It is set to 84 for other Drives.

Index	Sub-Index	Name	Default setting	Setting range	Unit	Size	Data attribute	PDO map	Corresponding Pn number
3110 hex	00 hex	Speed Feed-forward Gain	300	0 to 1000	0.1%	2 bytes (INT16)	B	Not possible.	Pn110
3111 hex	00 hex	Speed Feed-forward Command Filter	50	0 to 6400	0.01 ms	2 bytes (INT16)	B	Not possible.	Pn111
3112 hex	00 hex	Torque Feed-forward Gain	0	0 to 1000	0.1%	2 bytes (INT16)	B	Not possible.	Pn112
3113 hex	00 hex	Torque Feed-forward Command Filter	0	0 to 6400	0.01 ms	2 bytes (INT16)	B	Not possible.	Pn113
3114 hex	00 hex	Gain Switching Input Operating Mode Selection	1	0 to 1	–	2 bytes (INT16)	B	Not possible.	Pn114
3115 hex	00 hex	Switching Mode in Position Control	0	0 to 10	–	2 bytes (INT16)	B	Not possible.	Pn115
3116 hex	00 hex	Gain Switching Delay Time in Position Control	50	0 to 10000	0.1 ms	2 bytes (INT16)	B	Not possible.	Pn116
3117 hex	00 hex	Gain Switching Level in Position Control	50	0 to 20000	–	2 bytes (INT16)	B	Not possible.	Pn117
3118 hex	00 hex	Gain Switching Hysteresis in Position Control	33	0 to 20000	–	2 bytes (INT16)	B	Not possible.	Pn118
3119 hex	00 hex	Position Gain Switching Time	33	0 to 10000	0.1 ms	2 bytes (INT16)	B	Not possible.	Pn119
3120 hex	00 hex	Switching Mode in Speed Control	0	0 to 5	–	2 bytes (INT16)	B	Not possible.	Pn120
3121 hex	00 hex	Gain Switching Delay Time in Speed Control	0	0 to 10000	0.1 ms	2 bytes (INT16)	B	Not possible.	Pn121
3122 hex	00 hex	Gain Switching Level in Speed Control	0	0 to 20000	–	2 bytes (INT16)	B	Not possible.	Pn122
3123 hex	00 hex	Gain Switching Hysteresis in Speed Control	0	0 to 20000	–	2 bytes (INT16)	B	Not possible.	Pn123
3124 hex	00 hex	Switching Mode in Torque Control	0	0 to 3	–	2 bytes (INT16)	B	Not possible.	Pn124
3125 hex	00 hex	Gain Switching Delay Time in Torque Control	0	0 to 10000	0.1 ms	2 bytes (INT16)	B	Not possible.	Pn125
3126 hex	00 hex	Gain Switching Level in Torque Control	0	0 to 20000	–	2 bytes (INT16)	B	Not possible.	Pn126
3127 hex	00 hex	Gain Switching Hysteresis in Torque Control	0	0 to 20000	–	2 bytes (INT16)	B	Not possible.	Pn127
3200 hex	00 hex	Adaptive Filter Selection	0	0 to 4	–	2 bytes (INT16)	B	Not possible.	Pn200
3201 hex	00 hex	Notch 1 Frequency Setting	5000	50 to 5000	Hz	2 bytes (INT16)	B	Not possible.	Pn201
3202 hex	00 hex	Notch 1 Width Setting	2	0 to 20	–	2 bytes (INT16)	B	Not possible.	Pn202
3203 hex	00 hex	Notch 1 Depth Setting	0	0 to 99	–	2 bytes (INT16)	B	Not possible.	Pn203
3204 hex	00 hex	Notch 2 Frequency Setting	5000	50 to 5000	Hz	2 bytes (INT16)	B	Not possible.	Pn204
3205 hex	00 hex	Notch 2 Width Setting	2	0 to 20	–	2 bytes (INT16)	B	Not possible.	Pn205
3206 hex	00 hex	Notch 2 Depth Setting	0	0 to 99	–	2 bytes (INT16)	B	Not possible.	Pn206
3207 hex	00 hex	Notch 3 Frequency Setting	5000	50 to 5000	Hz	2 bytes (INT16)	B	Not possible.	Pn207
3208 hex	00 hex	Notch 3 Width Setting	2	0 to 20	–	2 bytes (INT16)	B	Not possible.	Pn208
3209 hex	00 hex	Notch 3 Depth Setting	0	0 to 99	–	2 bytes (INT16)	B	Not possible.	Pn209

Index	Sub-Index	Name	Default setting	Setting range	Unit	Size	Data attribute	PDO map	Corresponding Pn number
3210 hex	00 hex	Notch 4 Frequency Setting	5000	50 to 5000	Hz	2 bytes (INT16)	B	Not possible.	Pn210
3211 hex	00 hex	Notch 4 Width Setting	2	0 to 20	–	2 bytes (INT16)	B	Not possible.	Pn211
3212 hex	00 hex	Notch 4 Depth Setting	0	0 to 99	–	2 bytes (INT16)	B	Not possible.	Pn212
3213 hex	00 hex	Damping Filter Selection	0	0 to 3	–	2 bytes (INT16)	B	Not possible.	Pn213
3214 hex	00 hex	Damping Frequency 1	0	0 to 2000	0.1 Hz	2 bytes (INT16)	B	Not possible.	Pn214
3215 hex	00 hex	Damping Filter 1 Setting	0	0 to 1000	0.1 Hz	2 bytes (INT16)	B	Not possible.	Pn215
3216 hex	00 hex	Damping Frequency 2	0	0 to 2000	0.1 Hz	2 bytes (INT16)	B	Not possible.	Pn216
3217 hex	00 hex	Damping Filter 2 Setting	0	0 to 1000	0.1 Hz	2 bytes (INT16)	B	Not possible.	Pn217
3218 hex	00 hex	Damping Frequency 3	0	0 to 2000	0.1 Hz	2 bytes (INT16)	B	Not possible.	Pn218
3219 hex	00 hex	Damping Filter 3 Setting	0	0 to 1000	0.1 Hz	2 bytes (INT16)	B	Not possible.	Pn219
3220 hex	00 hex	Damping Frequency 4	0	0 to 2000	0.1 Hz	2 bytes (INT16)	B	Not possible.	Pn220
3221 hex	00 hex	Damping Filter 4 Setting	0	0 to 1000	0.1 Hz	2 bytes (INT16)	B	Not possible.	Pn221
3222 hex	00 hex	Position Command Filter Time Constant	0	0 to 10000	0.1 ms	2 bytes (INT16)	B	Not possible.	Pn222
3312 hex	00 hex	Soft Start Acceleration Time	0	0 to 10000	ms/max. motor speed	2 bytes (INT16)	B	Not possible.	Pn312
3313 hex	00 hex	Soft Start Deceleration Time	0	0 to 10000	ms/max. motor speed	2 bytes (INT16)	B	Not possible.	Pn313
3314 hex	00 hex	S-curve Acceleration/Deceleration Time Setting	0	0 to 1000	ms	2 bytes (INT16)	B	Not possible.	Pn314
3317 hex	00 hex	Speed Limit Selection	1	0 to 1	–	2 bytes (INT16)	B	Not possible.	Pn317
3321 hex	00 hex	Speed Limit Value Setting	20000	0 to 20000	r/min	2 bytes (INT16)	B	Not possible.	Pn321
3323 hex	00 hex	External Feedback Pulse Type Selection	0	0 to 2	–	2 bytes (INT16)	R	Not possible.	Pn323
3324 hex	00 hex	External Feedback Pulse Dividing Numerator	0	0 to 1048576	–	4 bytes (INT32)	R	Not possible.	Pn324
3325 hex	00 hex	External Feedback Pulse Dividing Denominator	10000	1 to 1048576	–	4 bytes (INT32)	R	Not possible.	Pn325
3326 hex	00 hex	External Feedback Pulse Direction Switching	0	0 to 1	–	2 bytes (INT16)	R	Not possible.	Pn326
3327 hex	00 hex	External Feedback Pulse Phase-Z Setting	0	0 to 1	–	2 bytes (INT16)	R	Not possible.	Pn327
3328 hex	00 hex	Hybrid Following Error Counter Overflow Level	16000	1 to 134217728	Command units	4 bytes (INT32)	C	Not possible.	Pn328
3329 hex	00 hex	Hybrid Following Error Counter Reset	0	0 to 100	Rotations	2 bytes (INT16)	C	Not possible.	Pn329
3400 hex	00 hex	Input Signal Selection 1	0094 9494 hex	0 to 00FF FFFF hex	–	4 bytes (INT32)	C	Not possible.	Pn400
3401 hex	00 hex	Input Signal Selection 2	0081 8181 hex	0 to 00FF FFFF hex	–	4 bytes (INT32)	C	Not possible.	Pn401

Index	Sub-Index	Name	Default setting	Setting range	Unit	Size	Data attribute	PDO map	Corresponding Pn number
3402 hex	00 hex	Input Signal Selection 3	0082 8282 hex	0 to 00FF FFFF hex	–	4 bytes (INT32)	C	Not possible.	Pn402
3403 hex	00 hex	Input Signal Selection 4	0022 2222 hex	0 to 00FF FFFF hex	–	4 bytes (INT32)	C	Not possible.	Pn403
3404 hex	00 hex	Input Signal Selection 5	002B 2B2B hex	0 to 00FF FFFF hex	–	4 bytes (INT32)	C	Not possible.	Pn404
3405 hex	00 hex	Input Signal Selection 6	0021 2121 hex	0 to 00FF FFFF hex	–	4 bytes (INT32)	C	Not possible.	Pn405
3406 hex	00 hex	Input Signal Selection 7	0020 2020 hex	0 to 00FF FFFF hex	–	4 bytes (INT32)	C	Not possible.	Pn406
3407 hex	00 hex	Input Signal Selection 8	002E 2E2E hex	0 to 00FF FFFF hex	–	4 bytes (INT32)	C	Not possible.	Pn407
3410 hex	00 hex	Output Signal Selection 1	0003 0303 hex	0 to 00FF FFFF hex	–	4 bytes (INT32)	C	Not possible.	Pn410
3411 hex	00 hex	Output Signal Selection 2	0002 0202 hex	0 to 00FF FFFF hex	–	4 bytes (INT32)	C	Not possible.	Pn411
3416 hex	00 hex	Analog Monitor 1 Selection	0	0 to 21	*1	2 bytes (INT16)	A	Not possible.	Pn416
3417 hex	00 hex	Analog Monitor 1 Scale Setting	0	0 to 214748364	–	4 bytes (INT32)	A	Not possible.	Pn417
3418 hex	00 hex	Analog Monitor 2 Selection	4	0 to 21	–	2 bytes (INT16)	A	Not possible.	Pn418
3419 hex	00 hex	Analog Monitor 2 Scale Setting	0	0 to 214748364	–	4 bytes (INT32)	A	Not possible.	Pn419
3421 hex	00 hex	Analog Monitor Output Setting	0	0 to 2	–	2 bytes (INT16)	A	Not possible.	Pn421
3432 hex	00 hex	Positioning Completion Condition Selection	0	0 to 3	–	2 bytes (INT16)	A	Not possible.	Pn432
3433 hex	00 hex	Positioning Completion Hold Time	0	0 to 30000	ms	2 bytes (INT16)	A	Not possible.	Pn433
3434 hex	00 hex	Zero Speed Detection	50	10 to 20000	r/min	2 bytes (INT16)	A	Not possible.	Pn434
3435 hex	00 hex	Speed Conformity Detection Range	50	10 to 20000	r/min	2 bytes (INT16)	A	Not possible.	Pn435
3436 hex	00 hex	Rotation Speed for Motor Rotation Detection	1000	10 to 20000	r/min	2 bytes (INT16)	A	Not possible.	Pn436
3437 hex	00 hex	Brake Timing when Stopped	0	0 to 10000	ms	2 bytes (INT16)	B	Not possible.	Pn437
3438 hex	00 hex	Brake Timing During Operation	0	0 to 10000	ms	2 bytes (INT16)	B	Not possible.	Pn438
3439 hex	00 hex	Brake Threshold Speed During Operation	30	30 to 3000	r/min	2 bytes (INT16)	B	Not possible.	Pn439
3440 hex	00 hex	Warning Output Selection 1	0	0 to 13	–	2 bytes (INT16)	A	Not possible.	Pn440
3441 hex	00 hex	Warning Output Selection 2	0	0 to 13	–	2 bytes (INT16)	A	Not possible.	Pn441
3442 hex	00 hex	Position Completion Range 2	10	0 to 262144	Command units	4 bytes (INT32)	A	Not possible.	Pn442
3504 hex	00 hex	Drive Prohibition Input Selection	1	0 to 2	–	2 bytes (INT16)	C	Not possible.	Pn504

*1 For units, refer to information on object 3416 hex on page 9-33.

Index	Sub-Index	Name	Default setting	Setting range	Unit	Size	Data attribute	PDO map	Corresponding Pn number
3505 hex	00 hex	Stop Selection for Drive Prohibition Input	0	0 to 2	–	2 bytes (INT16)	C	Not possible.	Pn505
3508 hex	00 hex	Undervoltage Error Selection	1	0 to 1	–	2 bytes (INT16)	B	Not possible.	Pn508
3509 hex	00 hex	Momentary Hold Time	70	70 to 2000	ms	2 bytes (INT16)	C	Not possible.	Pn509
3511 hex	00 hex	Immediate Stop Torque	0	0 to 5000	0.1%	2 bytes (INT16)	B	Not possible.	Pn755
3512 hex	00 hex	Overload Detection Level Setting	0	0 to 500 *1	–	2 bytes (INT16)	A	Not possible.	Pn512
3513 hex	00 hex	Overspeed Detection Level Setting	0	0 to 20000	r/min	2 bytes (INT16)	A	Not possible.	Pn513
3514 hex	00 hex	Overrun Limit Setting	10	0 to 1000	0.1 rotation	2 bytes (INT16)	A	Not possible.	Pn514
3515 hex	00 hex	Control Input Signal Read Setting	0	0 to 3	–	2 bytes (INT16)	C	Not possible.	Pn515
3520 hex	00 hex	Position Setting Unit Selection	0	0 to 1	–	2 bytes (INT16)	C	Not possible.	Pn520
3521 hex	00 hex	Torque Limit Selection	6	0 to 7	–	2 bytes (INT16)	B	Not possible.	Pn521
3522 hex	00 hex	External Torque Limit 2	5000	0 to 5000	0.1%	2 bytes (INT16)	B	Not possible.	Pn754
3525 hex	00 hex	Forward External Torque Limit	5000	0 to 5000	0.1%	2 bytes (INT16)	B	Not possible.	Pn730
3526 hex	00 hex	Reverse External Torque Limit	5000	0 to 5000	0.1%	2 bytes (INT16)	B	Not possible.	Pn731
3602 hex	00 hex	Excessive Speed Deviation Setting	0	0 to 20000	r/min	2 bytes (INT16)	B	Not possible.	Pn602
3605 hex	00 hex	Gain 3 Effective Time	0	0 to 10000	0.1 ms	2 bytes (INT16)	B	Not possible.	Pn605
3606 hex	00 hex	Gain 3 Ratio Setting	100	0 to 10000	%	2 bytes (INT16)	B	Not possible.	Pn606
3607 hex	00 hex	Torque Command Value Offset	0	50 to 1000	%	2 bytes (INT16)	B	Not possible.	Pn607
3608 hex	00 hex	Forward Direction Torque Offset	0	-100 to 100	%	2 bytes (INT16)	B	Not possible.	Pn608
3609 hex	00 hex	Reverse Direction Torque Offset	0	-100 to 100	%	2 bytes (INT16)	B	Not possible.	Pn609
3610 hex	00 hex	Function Expansion Setting	64	0 to 30000	–	2 bytes (INT16)	B	Not possible.	Pn610
3611 hex	00 hex	Electric Current Response Setting	100	50 to 100	%	2 bytes (INT16)	B	Not possible.	Pn611
3614 hex	00 hex	Error Detection Allowable Time Setting	200	0 to 1000	ms	2 bytes (INT16)	B	Not possible.	Pn614
3615 hex	00 hex	Overspeed Detection Level Setting at Immediate Stop	0	0 to 20000	r/min	2 bytes (INT16)	A	Not possible.	Pn615
3618 hex	00 hex	Power Supply ON Initialization Time	0	0 to 100	0.1 s	2 bytes (INT16)	R	Not possible.	Pn618
3623 hex	00 hex	Disturbance Torque Compensation Gain	0	-100 to 100	–	2 bytes (INT16)	B	Not possible.	Pn623
3624 hex	00 hex	Disturbance Observer Filter Setting	53	10 to 2500	0.01 ms	2 bytes (INT16)	B	Not possible.	Pn624
3631 hex	00 hex	Realtime Autotuning Estimated Speed Selection	1	0 to 3	–	2 bytes (INT16)	B	Not possible.	Pn631

*1 Regarded as 115% when set to 115 or more.

Index	Sub-Index	Name	Default setting	Setting range	Unit	Size	Data attribute	PDO map	Corresponding Pn number
3632 hex	00 hex	Realtime Autotuning Customization Mode Setting	0	-32768 to 32767	-	2 bytes (INT16)	B	Not possible.	Pn632
3634 hex	00 hex	Hybrid Vibration Suppression Gain	0	0 to 30000	0.1/s	2 bytes (INT16)	B	Not possible.	Pn634
3635 hex	00 hex	Hybrid Vibration Suppression Filter	10	0 to 6400	0.01ms	2 bytes (INT16)	B	Not possible.	Pn635
3637 hex	00 hex	Vibration Detection Threshold	0	0 to 1000	0.1%	2 bytes (INT16)	B	Not possible.	Pn637
3638 hex	00 hex	Warning Mask Setting	4	-32768 to 32767	-	2 bytes (INT16)	C	Not possible.	Pn638
3700 hex	00 hex	LED Display Selection	0	0 to 32767	-	2 bytes (INT16)	A	Not possible.	Pn700
3701 hex	00 hex	Power ON Address Display Duration Setting	0	0 to 1000	100ms	2 bytes (INT16)	R	Not possible.	Pn701
3703 hex	00 hex	Torque Limit Flag Output Setting	1	0 to 1	-	2 bytes (INT16)	A	Not possible.	Pn703
3704 hex	00 hex	Backlash Compensation Selection	0	0 to 2	-	2 bytes (INT16)	C	Not possible.	Pn704
3705 hex	00 hex	Backlash Compensation Amount	0	-32768 to 32767	Command units	2 bytes (INT16)	B	Not possible.	Pn705
3706 hex	00 hex	Backlash Compensation Time Constant	0	0 to 6400	0.01ms	2 bytes (INT16)	B	Not possible.	Pn706
3758 hex	00 hex	Touch Probe Trigger Selection	0100h	0000 to FFFF hex	-	2 bytes (U16)	B	Not possible.	Pn758
3759 hex	00 hex	Warning Hold Selection	0	0000 to FFFF hex	-	2 bytes (U16)	B	Not possible.	Pn759
3781 hex *1	00 hex	Data Setting Warning Detection Setting	1	0 to 15	-	2 bytes (INT16)	C	Not possible.	Pn781
3800 hex	00 hex	Communications Control	*2	-32768 to 32767	-	2 bytes (INT16)	C	Not possible.	Pn800
3801 hex	00 hex	Software Position Limit Function	3	0 to 3	-	2 bytes (INT16)	A	Not possible.	Pn801
3803 hex	00 hex	Origin Range	10	0 to 250	Command units	2 bytes (INT16)	A	Not possible.	Pn803
3818 hex	00 hex	Position Command FIR Filter Time Constant	0	0 to 10000	0.1 ms	2 bytes (INT16)	B	Not possible.	Pn818
3822 hex	00 hex	Origin Return Mode Settings	0	0 to 1	-	2 bytes (INT16)	B	Not possible.	Pn822
4000 hex	00 hex	Statusword 1	0000 hex	0000 to FFFF hex	-	2 bytes (U16)	RO	TxPDO	-
4001 hex	00 hex	Sub Error Code	0000 hex	0000 to FFFF hex	-	2 bytes (U16)	RO	TxPDO	-
4020 hex *3	00 hex	Reference Position for CSP	0	-2147483648 to 2147483647	Command units	4 bytes (INT32)	RO	TxPDO	-
4100 hex	00 hex	Config	0000 0000 hex	0000 0000 to FFFF FFFF hex	-	4 bytes (U32)	B	Not possible.	-
4102 hex	00 hex	Absolute Encoder Setup	0000 0000 hex	0000 0000 to FFFF FFFF hex	-	4 bytes (U32)	B	Not possible.	-
4103 hex	00 hex	Coordinate System Setting Mode	0	0000 to FFFF hex	-	2 bytes (U16)	B	RxPDO	-

*1 3781 hex is supported for unit version 2.1 or later.

*2 Default setting: 0 for unit version 2.0, 16384 for unit version 2.1.

*3 4020 hex is supported for unit version 2.1 or later.

Index	Sub-Index	Name	Default setting	Setting range	Unit	Size	Data attribute	PDO map	Corresponding Pn number
4104 hex	00 hex	Coordinate System Setting Position	0	-2147483648 to 2147483647	Command units	4 bytes (INT32)	B	RxPDO	-
4107 hex	00 hex	Error Reset	0000 0000 hex	0000 0000 to FFFF FFFF hex	-	4 bytes (U32)	A	Not possible.	-
603F hex	00 hex	Error code	0000 hex	0000 to FFFF hex	-	2 bytes (U16)	RO	TxPDO	-
6040 hex	00 hex	Controlword	0000 hex	0000 to FFFF hex	-	2 bytes (U16)	A	RxPDO	-
6041 hex	00 hex	Statusword	0000 hex	0000 to FFFF hex	-	2 bytes (U16)	RO	TxPDO	-
605B hex	00 hex	Shutdown option code	-1	-5 to 0	-	2 bytes (INT16)	B	Not possible.	Pn735
605C hex	00 hex	Disable operation option code	-1	-5 to 0	-	2 bytes (INT16)	B	Not possible.	Pn736
605D hex	00 hex	Halt option code	1	1 to 3	-	2 bytes (INT16)	B	Not possible.	Pn737
605E hex	00 hex	Fault reaction option code	-1	-7 to 0	-	2 bytes (INT16)	B	Not possible.	Pn738
6060 hex	00 hex	Modes of operation	0	0 to 10	-	1 byte (INT8)	A	RxPDO	-
6061 hex	00 hex	Modes of operation display	0	0 to 10	-	1 byte (INT8)	RO	TxPDO	-
6062 hex	00 hex	Position demand value	0	-2147483648 to 2147483647	Command units	4 bytes (INT32)	RO	TxPDO	-
6063 hex	00 hex	Position actual internal value	0	-2147483648 to 2147483647	Encoder units/ external encoder units*1	4 bytes (INT32)	RO	TxPDO	-
6064 hex	00 hex	Position actual value	0	-2147483648 to 2147483647	Command units	4 bytes (INT32)	RO	TxPDO	-
6065 hex	00 hex	Following error window	100000	0 to 134217728 or 4294967295	Command units	4 bytes (U32)	A	Not possible.	Pn739
6067 hex	00 hex	Position window	10	0 to 262144	Command units	4 bytes (U32)	A	Not possible.	Pn740
606C hex	00 hex	Velocity actual value	0	-2147483647 to 2147483647	Command units/s	4 bytes (INT32)	RO	TxPDO	-
6071 hex	00 hex	Target torque	0	-5000 to 5000	0.1%	2 bytes (INT16)	A	RxPDO	-
6072 hex	00 hex	Max torque	5000	0 to 5000	0.1%	2 bytes (U16)	A	RxPDO	-
6074 hex	00 hex	Torque demand	0	-5000 to 5000	0.1%	2 bytes (INT16)	RO	TxPDO	-
6077 hex	00 hex	Torque actual value	0	-5000 to 5000	0.1%	2 bytes (INT16)	RO	TxPDO	-
607A hex	00 hex	Target position	0	-2147483648 to 2147483647	Command units	4 bytes (INT32)	A	RxPDO	-
607C hex	00 hex	Home offset	0	-1073741823 to 1073741823	Command units	4 bytes (INT32)	C	Not possible.	Pn742

*1 Encoder units are used for semi-closed control and external encoder units are used for fully-closed control.

Index	Sub-Index	Name	Default setting	Setting range	Unit	Size	Data attribute	PDO map	Corresponding Pn number
607D hex		Software position limit	–	–	–	–	–	–	–
	00 hex	Number of entries	2	02 hex	–	1 byte (U8)	RO	Not possible.	–
	01 hex	Min position limit	–500000	–1073741823 to 1073741823	Command units	4 bytes (INT32)	A	Not possible.	Pn743
	02 hex	Max position limit	500000	–1073741823 to 1073741823	Command units	4 bytes (INT32)	A	Not possible.	Pn744
607F hex	00 hex	Max profile velocity	0	0 to 2147483647	Command units/s	4 bytes (U32)	A	RxPDO	–
6081 hex *1	00 hex	Profile velocity	0	0 to 2147483647	Command units/s	4 bytes (U32)	A	RxPDO	–
6083 hex	00 hex	Profile acceleration	1000000	1 to 655350000	Command units/s ²	4 bytes (U32)	B	Not possible.	Pn745
6084 hex	00 hex	Profile deceleration	1000000	1 to 655350000	Command units/s ²	4 bytes (U32)	B	Not possible.	Pn746
6086 hex	00 hex	Motion profile type	0	–1 to 0	–	2 bytes (INT16)	B	RxPDO	–
6091 hex		Gear ratio	–	–	–	–	–	–	–
	00 hex	Number of entries	02 hex	–	–	1 byte (U8)	RO	Not possible.	–
	01 hex	Motor revolutions	1	0 to 1073741824	–	4 bytes (U32)	C	Not possible.	Pn748
	02 hex	Shaft revolutions	1	1 to 1073741824	–	4 bytes (U32)	C	Not possible.	Pn749
6098 hex	00 hex	Homing method	0	–128 to 127	–	1 byte (INT8)	B	Not possible.	Pn750
6099 hex		Homing speeds	–	–	–	–	–	–	–
	00 hex	Number of entries	02 hex	–	–	1 byte (U8)	RO	Not possible.	–
	01 hex	Speed during search for switch	5000	100 to 3276700	Command units/s	4 bytes (U32)	B	Not possible.	Pn751
	02 hex	Speed during search for zero	5000	100 to 3276700	Command units/s	4 bytes (U32)	B	Not possible.	Pn752
60B0 hex	00 hex	Position offset	0	–2147483648 to 2147483647	Command units	4 bytes (INT32)	A	RxPDO	–
60B1 hex	00 hex	Velocity offset	0	–2147483648 to 2147483647	Command units/s	4 bytes (INT32)	A	RxPDO	–
60B2 hex	00 hex	Torque offset	0	–5000 to 5000	0.1%	2 bytes (INT16)	A	RxPDO	–
60B8 hex	00 hex	Touch probe function	0	–	–	2 bytes (U16)	A	RxPDO	–
60B9 hex	00 hex	Touch probe status	0	–	–	2 bytes (U16)	RO	TxPDO	–
60BA hex	00 hex	Touch probe pos1 pos value	0	–2147483648 to 2147483647	Command units	4 bytes (INT32)	RO	TxPDO	–
60BC hex	00 hex	Touch probe pos2 pos value	0	–2147483648 to 2147483647	Command units	4 bytes (INT32)	RO	TxPDO	–
60E0 hex	00 hex	Positive torque limit value	5000	0 to 5000	0.1%	2 bytes (U16)	A	RxPDO	–

*1 6081 hex is supported for unit version 2.1 or later.

Index	Sub-Index	Name	Default setting	Setting range	Unit	Size	Data attribute	PDO map	Corresponding Pn number
60E1 hex	00 hex	Negative torque limit value	5000	0 to 5000	0.1%	2 bytes (U16)	A	RxPDO	–
60E3 hex		Supported homing method	–	–	–	–	–	–	–
	00 hex	Number of entries	07 hex	–	–	1 byte (U8)	RO	Not possible.	–
	01 hex	1st supported homing method	8	–	–	2 bytes (U16)	RO	Not possible.	–
	02 hex	2st supported homing method	12	–	–	2 bytes (U16)	RO	Not possible.	–
	03 hex	3rd supported homing method	19	–	–	2 bytes (U16)	RO	Not possible.	–
	04 hex	4th supported homing method	20	–	–	2 bytes (U16)	RO	Not possible.	–
	05 hex	5th supported homing method	33	–	–	2 bytes (U16)	RO	Not possible.	–
	06 hex	6st supported homing method	34	–	–	2 bytes (U16)	RO	Not possible.	–
	07 hex	7th supported homing method	35	–	–	2 bytes (U16)	RO	Not possible.	–
60F4 hex	00 hex	Following error actual value	0	–536870912 to 536870912	Command units	4 bytes (INT32)	RO	TxPDO	–
60FA hex	00 hex	Control effort	0	–1073741823 to 1073741823	Command units/s	4 bytes (INT32)	RO	TxPDO	–
60FC hex	00 hex	Position demand internal value	0	–1073741823 to 1073741823	Encoder units	4 bytes (INT32)	RO	TxPDO	–
60FD hex	00 hex	Digital inputs	0000 0000 hex	0000 0000 to FFFF FFFF hex	–	4 bytes (U32)	RO	TxPDO	–
60FE hex		Digital outputs	–	–	–	–	–	–	–
	00 hex	Number of entries	02 hex	–	–	1 byte (U8)	RO	Not possible.	–
	01 hex	Physical outputs	0000 0000 hex	0000 0000 to FFFF FFFF hex	–	4 bytes (U32)	A	RxPDO	–
	02 hex	Bit mask	0000 0000 hex	0000 0000 to FFFF FFFF hex	–	4 bytes (U32)	B	Not possible.	–
60FF hex	00 hex	Target velocity	0	–2147483647 to 2147483647	Command units/s	4 bytes (INT32)	A	RxPDO	–
6402 hex	00 hex	Motor type	3	–	–	2 bytes (U16)	RO	Not possible.	–
6502 hex	00 hex	Supported drive modes	*1	–	–	4 bytes (U32)	RO	Not possible.	–

*1 Default setting: 0000 03A0 hex for unit version 2.0, 0000 03A1 hex for unit version 2.1.

A-3 Sysmac Error Status Codes

This section lists and describes the error event codes that you may see in Sysmac Studio. This function is supported for unit version 2.1 or later.

A-3-1 Error Table

The errors that may occur for this Unit are listed below. Event levels are given in the table as follows:

Maj: Major fault level

Prt: Partial fault level

Min: Minor fault level

Obs: Observation

Info: Information

Refer to the *NJ-series Troubleshooting Manual* (Cat. No. W503) for all of the event codes that may occur in an NJ-series Controller.

Event code	Event name	Meaning	Assumed cause	Level					Reference
				Maj	Prt	Min	Obs	Info	
04A80000 hex	Control Power Supply Undervoltage	The voltage between the positive and negative terminals in the control power supply converter dropped below the specified value.	<ul style="list-style-type: none"> Power supply undervoltage. Or, the power supply voltage dropped because there was inrush current when the main power supply was turned ON. A momentary power interruption occurred. The Servo Drive failed. 			√			page A-109
04A90000 hex	Overvoltage	The power supply voltage exceeded the allowable input voltage range.	<ul style="list-style-type: none"> The voltage between the positive and negative terminals in the control power supply converter exceeded the specified value. The voltage was suddenly increased by the phase advance capacitor or the uninterruptible power supply (UPS). The Regeneration Resistor wiring is broken. The External Regeneration Resistor is not suitable. The Servo Drive failed. 			√			page A-110

Event code	Event name	Meaning	Assumed cause	Level					Reference
				Maj	Prt	Min	Obs	Info	
04AA0000 hex	Main Circuit Power Supply Undervoltage (Undervoltage between positive and negative terminals)	If the Undervoltage Error Selection (3508 hex) is set to 1, a momentary power interruption occurred between L1 and L3 for longer than the value specified for the Momentary Hold Time. The voltage between the positive and negative terminals in the main power supply converter dropped below the specified value while the Servo was ON.	<ul style="list-style-type: none"> Insufficient power supply capacity The electromagnetic contactor in the main circuit power supply was tripped. A momentary power interruption occurred. A Servo Drive with 3-phase input specifications was operated with a single-phase power supply. The Servo Drive failed. 			√			page A-111
04AB0000 hex	Main Circuit Power Supply Undervoltage (AC Cutoff Detected)	If the Undervoltage Error Selection (3508 hex) is set to 1, a momentary power interruption occurred between L1 and L3 for longer than the value specified for the Momentary Hold Time. The voltage between the positive and negative terminals in the main power supply converter dropped below the specified value while the Servo was ON.	<ul style="list-style-type: none"> Insufficient power supply capacity The electromagnetic contactor in the main circuit power supply was tripped. A momentary power interruption occurred. A Servo Drive with 3-phase input specifications was operated with a single-phase power supply. The Servo Drive failed. 			√			page A-112
04AC0000 hex	Overcurrent	The current flowing through the converter exceeded the specified value.	<ul style="list-style-type: none"> A short-circuit, line-to-ground fault, contact failure, or insulation failure occurred on the U, V, or W motor line. The Servo Drive failed. The relay for the dynamic brake has been welded due to frequent Servo ON/OFF operations. Motor windings are burned out. The Servomotor is not suitable for the Servo Drive. The command input timing is the same as or earlier than the Servo ON timing. 			√			page A-113

Event code	Event name	Meaning	Assumed cause	Level					Reference
				Maj	Prt	Min	Obs	Info	
04AD0000 hex	IPM Error	The current flowing through the converter exceeded the specified value.	<ul style="list-style-type: none"> A short-circuit, line-to-ground fault, contact failure, or insulation failure occurred on the U, V, or W motor line. The Servo Drive failed. The relay for the dynamic brake has been welded due to frequent Servo ON/OFF operations. Motor windings are burned out. The Servomotor is not suitable for the Servo Drive. The pulse input timing is the same as or earlier than the Servo ON timing. 			√			page A-114
04AE0000 hex	Regeneration Tr Error	The Servo Drive regeneration drive Tr is faulty.	<ul style="list-style-type: none"> The Servo Drive regeneration drive Tr is faulty. 			√			page A-115
04AF0000 hex	Encoder Phase-Z Error	A missing serial incremental encoder phase-Z pulse was detected.	<ul style="list-style-type: none"> The encoder is faulty. 			√			page A-115
04B00000 hex	Encoder CTS Signal Error	A missing serial incremental encoder CTS signal logic error was detected.	<ul style="list-style-type: none"> The encoder is faulty. 			√			page A-116
04B10000 hex	Node Address Setting Error	The node address that was read from the rotary switches was not between 00 and 99.	<ul style="list-style-type: none"> The Servo Drive failed. 			√			page A-116
08080000 hex	Encoder Communications Disconnection Error	A disconnection was detected because communications between the encoder and the Servo Drive were stopped more frequently than the specified value.	<ul style="list-style-type: none"> The encoder is not wired correctly. 			√			page A-117
08090000 hex	Encoder Communications Error	There is a communications error for the encoder.	<ul style="list-style-type: none"> The power supply voltage of the encoder is low. Noise 			√			page A-117
080A0000 hex	Encoder Communications Data Error	There is an error in the communications data of the encoder.	<ul style="list-style-type: none"> The power supply voltage of the encoder is low. Noise 			√			page A-118
080B0000 hex	Safety Input Error	At least one of the input photocouplers for safety inputs 1 and 2 turned OFF.	<ul style="list-style-type: none"> The cable is disconnected or broken. 			√			page A-118

Event code	Event name	Meaning	Assumed cause	Level					Reference
				Maj	Prt	Min	Obs	Info	
080C0000 hex	External Encoder Connection Error	A disconnection was detected because communications between the external encoder and the Servo Drive were stopped more frequently than the specified value.	<ul style="list-style-type: none"> The wiring is incorrect. 			√			page A-119
080D0000 hex	External Encoder Communications Data Error	There was a communications error in data from the external encoder.	<ul style="list-style-type: none"> There is insufficient external encoder power supply voltage. Noise 			√			page A-119
080E0000 hex	External Encoder Status Error 0	Bit 00 of the external encoder error code (ALMC) was set to 1.	<ul style="list-style-type: none"> Bit 00 of the external scale error code (ALMC) was set to 1. 			√			page A-120
080F0000 hex	External Encoder Status Error 1	Bit 01 of the external encoder error code (ALMC) was set to 1.	<ul style="list-style-type: none"> Bit 01 of the external encoder error code (ALMC) was set to 1. 			√			page A-120
08100000 hex	External Encoder Status Error 2	Bit 02 of the external encoder error code (ALMC) was set to 1.	<ul style="list-style-type: none"> Bit 02 of the external encoder error code (ALMC) was set to 1. 			√			page A-121
08110000 hex	External Encoder Status Error 3	Bit 03 of the external encoder error code (ALMC) was set to 1.	<ul style="list-style-type: none"> Bit 03 of the external encoder error code (ALMC) was set to 1. 			√			page A-121
08120000 hex	External Encoder Status Error 4	Bit 04 of the external encoder error code (ALMC) was set to 1.	<ul style="list-style-type: none"> Bit 04 of the external encoder error code (ALMC) was set to 1. 			√			page A-122
08130000 hex	External Encoder Status Error 5	Bit 05 of the external encoder error code (ALMC) was set to 1.	<ul style="list-style-type: none"> Bit 05 of the external encoder error code (ALMC) was set to 1. 			√			page A-122
08140000 hex	Phase-A Connection Error	An error such as broken wiring was detected in the external encoder phase-A connection.	<ul style="list-style-type: none"> An error such as broken wiring was detected in the external encoder phase-A connection. 			√			page A-123
08150000 hex	Phase-B Connection Error	An error such as broken wiring was detected in the external encoder phase-B connection.	<ul style="list-style-type: none"> An error such as broken wiring was detected in the external encoder phase-B connection. 			√			page A-123
08160000 hex	Phase-Z Connection Error	An error such as broken wiring was detected in the external encoder phase-Z connection.	<ul style="list-style-type: none"> An error such as broken wiring was detected in the external encoder phase-Z connection. 			√			page A-124

Event code	Event name	Meaning	Assumed cause	Level					Reference
				Maj	Prt	Min	Obs	Info	
08170000 hex	Encoder Data Restoration Error	Initialization of internal position data was not processed correctly in Semi-closed Control Mode and Absolute Value Mode.	<ul style="list-style-type: none"> There is insufficient power supply voltage for the encoder. Noise is entering on the encoder line. 			√			page A-124
08180000 hex	External Encoder Data Restoration Error	Initialization of internal position data was not processed correctly in Fully-closed Control Mode and Absolute Value Mode.	<ul style="list-style-type: none"> There is insufficient power supply voltage for the external encoder. Noise is entering on the external encoder line. 			√			page A-125
14A80000 hex	Object Error	The object area data in non-volatile memory is corrupted.	<ul style="list-style-type: none"> Noise Non-volatile memory failure 			√			page A-125
14A90000 hex	Object Error	The object area data in non-volatile memory is corrupted.	<ul style="list-style-type: none"> Noise Non-volatile memory failure 			√			page A-126
14AA0000 hex	Object Error	The object area data in non-volatile memory is corrupted.	<ul style="list-style-type: none"> Noise Non-volatile memory failure 			√			page A-126
14AB0000 hex	Object Corrupted	The checksum data in non-volatile memory is corrupted.	<ul style="list-style-type: none"> Non-volatile memory failure 			√			page A-127
14AC0000 hex	Object Corrupted	The checksum data in non-volatile memory is corrupted.	<ul style="list-style-type: none"> Non-volatile memory failure 			√			page A-127
14AD0000 hex	Object Corrupted	The checksum data in non-volatile memory is corrupted.	<ul style="list-style-type: none"> Non-volatile memory failure 			√			page A-128
18200000 hex	Absolute Encoder Overspeed Error	The Servomotor rotation speed exceeded the specified value when only the battery power supply was used during a power interruption.	<ul style="list-style-type: none"> There is insufficient power supply voltage for the encoder. The wiring of the CN2 connector is wrong. An external force is rotating the motor when the Servo is OFF. 			√			page A-128
18210000 hex	Encoder Initialization Error	An encoder initialization error was detected.	<ul style="list-style-type: none"> Servomotor failed. 			√			page A-129
18220000 hex	Absolute Encoder One-rotation Counter Error	The encoder detected a one-rotation counter error.	<ul style="list-style-type: none"> Servomotor failed. 			√			page A-129
18230000 hex	Absolute Encoder Multi-rotation Counter Error	The encoder detected a multi-rotation counter error.	<ul style="list-style-type: none"> Servomotor failed. 			√			page A-130

Event code	Event name	Meaning	Assumed cause	Level					Reference
				Maj	Prt	Min	Obs	Info	
24680000 hex	Motor Non-conformity	The Servo Drive and Servomotor combination is not correct.	<ul style="list-style-type: none"> The Servo Drive and Servomotor combination is not correct. 			√			page A-130
24690000 hex	Motor Non-conformity	The Servo Drive and Servomotor combination is not correct.	<ul style="list-style-type: none"> The Servo Drive and Servomotor combination is not correct. 			√			page A-131
246A0000 hex	Motor Non-conformity	The Servo Drive and Servomotor combination is not correct.	<ul style="list-style-type: none"> The Servo Drive and Servomotor combination is not correct. 			√			page A-131
246B0000 hex	Motor Non-conformity	The Servo Drive and Servomotor combination is not correct.	<ul style="list-style-type: none"> The Servo Drive and Servomotor combination is not correct. 			√			page A-132
246C0000 hex	Motor Non-conformity	The Servo Drive and Servomotor combination is not correct.	<ul style="list-style-type: none"> The Servo Drive and Servomotor combination is not correct. 			√			page A-132
34E10000 hex	Servo Drive Overheat	The temperature of the Servo Drive radiator or power elements exceeded the specified value.	<ul style="list-style-type: none"> The ambient temperature of the Servo Drive exceeded the specified value. Overload 			√			page A-133
34E20000 hex	Overload	When the feedback value for torque command exceeds the overload level specified in the Overload Detection Level Setting (3512 hex), overload protection is performed according to the overload characteristics.	<ul style="list-style-type: none"> Operation was continued for a long time while overloaded. There is incorrect wiring of the motor line or a broken cable. 			√			page A-134
34E30000 hex	Regeneration Overload	The regenerative energy exceeds the processing capacity of the Regeneration Resistor.	<ul style="list-style-type: none"> The load inertia is too large. Or, the Servomotor rotation speed is too high to absorb the regenerative energy within the specified deceleration time. This Regeneration Resistor cannot be used for continuous regenerative braking. (The operating limit of the external resistor is limited to a 10% duty.) 			√			page A-135
34E40000 hex	Error Counter Overflow	Position error pulses exceeded the setting of the Following error window (6065 hex).	<ul style="list-style-type: none"> Motor operation does not follow the command. The value of the Following error window (6065 hex) is small. The encoder wiring is incorrect. 			√			page A-136

Event code	Event name	Meaning	Assumed cause	Level					Reference
				Maj	Prt	Min	Obs	Info	
34E50000 hex	Excessive Velocity Error	The difference between the internal position command velocity and the actual velocity (i.e., the velocity error) exceeded the Excessive Velocity Error Setting (3602 hex).	<ul style="list-style-type: none"> Motor operation does not follow the command. The setting of the Excessive Velocity Error Setting (3602 hex) is too small. 			√			page A-137
34E60000 hex	Overspeed	The Servomotor rotation speed exceeded the value set on the Overspeed Detection Level Setting (3513 hex).	<ul style="list-style-type: none"> The velocity command value is too large. There is overshooting. The wiring is incorrect. 			√			page A-137
383F0000 hex	Excessive Hybrid Following Error	During fully-closed control, the difference between the load position from the external encoder and the Servomotor position from the encoder was larger than the number of pulses set as the Hybrid Following Error Counter Overflow Level (3328 hex).	<ul style="list-style-type: none"> Connections are not correct. The settings are not correct. 			√			page A-138
38400000 hex	Overspeed 2	The Servomotor rotation speed exceeded the value set on Overspeed Detection Level Setting at Immediate Stop (3615 hex).	<ul style="list-style-type: none"> The velocity command value is too large. There is overshooting. The wiring is incorrect. 			√			page A-139
38410000 hex	Command Error	The position command variation after the electronic gear exceeded the specified value.	<ul style="list-style-type: none"> The change in position command is too large. The backlash compensation amount is too large. 			√			page A-139
38420000 hex	Command Generation Error	During position command processing, an error such as a calculation range error occurred.	<ul style="list-style-type: none"> During position command processing, an error such as a calculation range error occurred. 			√			page A-140
38430000 hex	Error Counter Overflow 1	The absolute encoder (absolute scale) position in pulses divided by the electronic gear ratio exceeded $\pm 2^{31}$ (2,147,483,648).	<ul style="list-style-type: none"> The absolute encoder (absolute scale) position in pulses divided by the electronic gear ratio exceeded $\pm 2^{31}$ (2,147,483,648). 			√			page A-140

Event code	Event name	Meaning	Assumed cause	Level					Reference
				Maj	Prt	Min	Obs	Info	
38440000 hex	Error Counter Overflow 2	The position following error in pulses exceeded $\pm 2^{29}$ (536,870,912). Or, the position following error in command units exceeded $\pm 2^{30}$ (1,073,741,824).	<ul style="list-style-type: none"> There is insufficient torque. There is insufficient gain. The encoder wiring is incorrect. 			√			page A-141
38450000 hex	Interface Input Duplicate Allocation Error 1	There is a duplicate setting in the input signal (IN1, IN2, IN3, and IN4) function allocations.	<ul style="list-style-type: none"> There is a duplicate setting in the input signal (IN1, IN2, IN3, and IN4) function allocations. 			√			page A-141
38460000 hex	Interface Input Duplicate Allocation Error 2	There is a duplicate setting in the input signal (IN5, IN6, IN7, and IN8) function allocations.	<ul style="list-style-type: none"> There is a duplicate setting in the input signal (IN5, IN6, IN7, and IN8) function allocations. 			√			page A-142
38470000 hex	Interface Input Function Number Error 1	There is an undefined number specification in the input signal (IN1, IN2, IN3, and IN4) function allocations. Or, a logic setting error was detected.	<ul style="list-style-type: none"> There is an undefined number specification in the input signal (IN1, IN2, IN3, and IN4) function allocations. Different logic is set for the same function in the function assignments of the input signals (IN1, IN2, IN3, and IN4). 			√			page A-143
38480000 hex	Interface Input Function Number Error 2	There is an undefined number specification in the input signal (IN5, IN6, IN7, and IN8) function allocations. Or, a logic setting error was detected.	<ul style="list-style-type: none"> There is an undefined number specification in the input signal (IN5, IN6, IN7, and IN8) function allocations. Different logic is set for the same function in the function assignments of the input signals (IN5, IN6, IN7, and IN8). 			√			page A-144
38490000 hex	Interface Output Function Number Error 1	There is an undefined number specification in the output signal (OUTM1) function allocation.	<ul style="list-style-type: none"> There is an undefined number specification in the output signal (OUTM1) function allocation. 			√			page A-145
384A0000 hex	Interface Output Function Number Error 2	There is an undefined number specification in the output signal (OUTM2) function allocation.	<ul style="list-style-type: none"> There is an undefined number specification in the output signal (OUTM2) function allocation. 			√			page A-145
384B0000 hex	External Latch Input Allocation Error	There is an error in the latch input function allocation.	<ul style="list-style-type: none"> The latch input was allocated to an input signal other than IN5, IN6, or IN7. A latch input is assigned to an NC signal. The same latch input is not assigned to the same pin in all Control Modes. 			√			page A-146

Event code	Event name	Meaning	Assumed cause	Level					Reference
				Maj	Prt	Min	Obs	Info	
384C0000 hex	Overrun Limit Error	The Servomotor exceeded the allowable operating range set in the Overrun Limit Setting (3514 hex) with respect to the position command input range.	<ul style="list-style-type: none"> The gain or inertial ratio is not suitable. The set value of the Overrun Limit Setting (3514 hex) is too small. 			√			page A-146
384D0000 hex	Absolute Encoder System Down Error	The voltage of the built-in capacitor dropped below the specified value because the power supply to the encoder or the battery power supply was down.	<ul style="list-style-type: none"> The voltage of the built-in capacitor dropped below the specified value because the power supply to the encoder or the battery power supply was down. 			√			page A-147
384E0000 hex	Absolute Encoder Counter Overflow Error	The multi-rotation counter of the encoder exceeded the specified value.	<ul style="list-style-type: none"> The set value for switching operation with the absolute encoder is too large. The traveling distance from home of the machine exceeded 32,767 revolutions. 			√			page A-148
384F0000 hex	Object Setting Error 1	The electronic gear ratio exceeded the allowable range.	<ul style="list-style-type: none"> The electronic gear ratio exceeded the allowable range. 			√			page A-148
38500000 hex	Object Setting Error 2	External encoder ratio exceeded the allowable range.	<ul style="list-style-type: none"> External encoder ratio exceeded the allowable range. 			√			page A-149
38510000 hex	External Encoder Connection Error	The set value of the External Feedback Pulse Type Selection (3323 hex) differs from the external encoder type that is connected for serial communications.	<ul style="list-style-type: none"> The set value of the External Feedback Pulse Type Selection (3323 hex) differs from the external encoder type that is connected for serial communications. 			√			page A-149

Event code	Event name	Meaning	Assumed cause	Level					Reference
				Maj	Prt	Min	Obs	Info	
38520000 hex	Function Setting Error	The function that was set does not support the communications period.	<ul style="list-style-type: none"> The electronic gear object ratio was not 1:1 when the communications period was set to 250 or 500 μs. Fully-closed Control Mode was selected for a communications period setting of 250 μs. Modes of operation (6060 hex) was set to pp or hm when the communications period was set to 250 or 500 μs. More than 20 bytes were mapped for RxPDO when the communications period was set to 250 μs. More than 12 bytes were mapped for RxPDO in Fully-closed Control Mode. Modes of operation (6060 hex) was set to pp or hm in Fully-closed Control Mode when the communications period was set to 1 ms and the electronic gear parameter ratio was not set to 1:1. No bytes (i.e., no objects) were mapped for RxPDO. More than 10 objects were mapped for RxPDO. More than 11 objects were mapped for TxPDO. CSP Switching Reference Position (4020 hex) was mapped for TxPDO when the communications period was set to 250 or 500 μs or when the electronic gear object ratio was not set to 1:1. 			√			page A-150
64E00000 hex	Drive Prohibition Input Error 1	When the Drive Prohibition Input Selection (3504 hex) was set to 0, both the Forward Drive Prohibition Input (POT) and the Reverse Drive Prohibition Input (NOT) turned ON. Or, when the Drive Prohibition Input Selection (3504 hex) was set to 2, either the Forward Drive Prohibition Input (POT) or the Reverse Drive Prohibition Input (NOT) turned ON.	<ul style="list-style-type: none"> A problem occurred with the switches, wires, and power supplies that are connected to the Forward Drive Prohibition input or the Reverse Drive Prohibition input. 			√			page A-151

Event code	Event name	Meaning	Assumed cause	Level					Reference
				Maj	Prt	Min	Obs	Info	
64E10000 hex	Drive Prohibition Input Error 2	An operation command (such as a trial run of FFT) was received from the CX-Drive when the Drive Prohibition Input Selection (3504 hex) was set to 0, EtherCAT communications was interrupted, and either POT or NOT was ON. Or, POT or NOT turned ON while operation was being performed for a CX-Drive operation command.	<ul style="list-style-type: none"> A problem occurred with the switches, wires, and power supplies that are connected to the Forward Drive Prohibition input or the Reverse Drive Prohibition input. 			√			page A-151
64E20000 hex	Immediate Stop Input Error	An Immediate Stop (STOP) signal was input.	<ul style="list-style-type: none"> An Immediate Stop (STOP) signal was input. Incorrect wiring of the immediate stop input (STOP). 			√			page A-152
74810000 hex	Command Error	A mistake was made in using a command.	<ul style="list-style-type: none"> When bit 09 (Remote) of the Statusword (6041 hex) was set to 1 (remote), and the Servo Drive was in operation enabled state (Servo ON), a command was received that changes the communications state from Operational to another state (Init, Pre-operational, or Safe-operational state). When bit 09 (Remote) of the Statusword (6041 hex) was set to 0 (local), a command was received during FFT or test run status that changes the ESM state from Operational, Safe-operational, or Pre-operational state to Init state. An unsupported number was set for 6060 hex (Operation Mode). During Fully-closed Control Mode, csv or cst was set for 6060 hex (Operation Mode). The setting of 6060 hex (Operation Mode) was changed at an interval of less than 2 ms. Homing was started when 6098 hex (Homing Method) was set to a value other than 8, 12, 19, 20, 33, 34, or 35. Data setting warnings (B0 hex) occurred continuously for the number of data setting warnings that is set in 3781 hex (Data Setting Warning Detection Count). 			√			page A-153

Event code	Event name	Meaning	Assumed cause	Level					Reference
				Maj	Prt	Min	Obs	Info	
78010000 hex	Operation Command Competition	An attempt was made to establish EtherCAT communications or to turn ON the Servo from the Controller (enable operation) while executing an FFT that operates with the Servo Drive alone or a trial run.	<ul style="list-style-type: none"> EtherCAT communications (change from Init to Pre-operational state) was established or an attempt to turn ON the Servo from the Controller (enable operation) was made while executing an FFT that operates with the Servo Drive trial run. 			√			page A-154
78020000 hex	Absolute Encoder Status Error	The rotation of the encoder was higher than the specified value when the power supply was turned ON.	<ul style="list-style-type: none"> The rotation of the encoder was higher than the specified value when the power supply was turned ON. 			√			page A-154
84B10000 hex	EtherCAT State Change Error	A communications state change command was received for which the current communications state could not be changed.	<ul style="list-style-type: none"> A communications state change command was received for which the current communications state could not be changed. 			√			page A-155
84B20000 hex	EtherCAT Illegal State Change Error	An undefined communications state change command was received.	<ul style="list-style-type: none"> An undefined communications state change command was received. 			√			page A-155
84B30000 hex	Communications Synchronization Error	The number of consecutive errors in receiving data during the communication sync time exceeded the value specified for the Communications Error Setting (2200 hex).	<ul style="list-style-type: none"> Power to the host controller was interrupted during PDO communications. An EtherCAT communications cable is disconnected, broken, or incorrectly connected. Noise 			√			page A-156
84B40000 hex	Synchronization Error	A synchronization error occurred.	<ul style="list-style-type: none"> Noise Control PCB error 			√			page A-156
84B50000 hex	Sync Manager WDT Error	PDO communications were stopped for more than the specified period of time.	<ul style="list-style-type: none"> The EtherCAT communications cable is disconnected or broken. There is an error in the host controller. 			√			page A-157
84B60000 hex	ESC Initialization Error	An error occurred in ESC initialization.	<ul style="list-style-type: none"> Control PCB error 			√			page A-157
84B70000 hex	Slave Unit Verification Error	An error occurred in Slave Unit verification.	<ul style="list-style-type: none"> Control PCB error 			√			page A-158
84B80000 hex	Communications Setting Error	There is an error in the communications settings.	<ul style="list-style-type: none"> An out-of-range value was set from the host controller. A command that changes the communications state to an unsupported state was received. 			√			page A-158

Event code	Event name	Meaning	Assumed cause	Level					Reference
				Maj	Prt	Min	Obs	Info	
84B90000 hex	Synchronization Interruption Error	A synchronization interruption error occurred.	<ul style="list-style-type: none"> Control PCB error 			√			page A-159
98010000 hex	Absolute Value Cleared	The multi-rotation counter for the absolute encoder was cleared during USB communications by the CX-Drive.	<ul style="list-style-type: none"> The multi-rotation counter for the absolute encoder was cleared during USB communications by the CX-Drive. 			√			page A-159
98020000 hex	Position Data Initialized	A Config operation was performed or the multi-rotation counter was cleared for the absolute encoder during EtherCAT communications.	<ul style="list-style-type: none"> A Config operation was performed or the multi-rotation counter was cleared for the absolute encoder during EtherCAT communications. 			√			page A-160
08010000 hex	Battery Warning	The battery voltage is 3.2 V or less.	<ul style="list-style-type: none"> The battery voltage is 3.2 V or lower. 				√		page A-160
08020000 hex	Fan Warning	The fan stop state continued for 1 second.	<ul style="list-style-type: none"> There is foreign matter in the fan. The Servo Drive failed. 				√		page A-161
08030000 hex	Encoder Communications Warning	Encoder communications errors occurred in series more frequently than the specified value.	<ul style="list-style-type: none"> There is insufficient power supply voltage for the encoder. Noise is entering on the encoder line. 				√		page A-161
08040000 hex	Encoder Overheating Warning	The encoder temperature exceeded the specified value.	<ul style="list-style-type: none"> The ambient temperature is too high. Servomotor failed. 				√		page A-162
08050000 hex	Life Expectancy Warning	The remaining life of the capacitor or the fan is shorter than the specified value.	<ul style="list-style-type: none"> The life expectancy of the capacitor or the fan is shorter than the specified value. 				√		page A-162
08060000 hex	External Encoder Error Warning	The external encoder detected a warning.	<ul style="list-style-type: none"> There is insufficient power supply voltage for the external encoder. Noise is entering on the external encoder connector cable. The external encoder failed. 				√		page A-163
08070000 hex	External Encoder Communications Warning	The external encoder had more communications errors than the specified value.	<ul style="list-style-type: none"> There is insufficient power supply voltage for the external encoder. Noise is entering on the external encoder connector cable. 				√		page A-163
34E00000 hex	Data Setting Warning	An object setting is out of range.	<ul style="list-style-type: none"> An object setting is out of range. 				√		page A-164
383C0000 hex	Overload Warning	The load ratio is 85% or more of the protection level.	<ul style="list-style-type: none"> Overload There is incorrect wiring of the motor line or a broken cable. 				√		page A-164
383D0000 hex	Excessive Regeneration Warning	The regeneration load ratio is 85% or more of the level.	<ul style="list-style-type: none"> There is excessive regeneration. This Regeneration Resistor cannot be used for continuous regenerative braking. 				√		page A-165

Event code	Event name	Meaning	Assumed cause	Level					Reference
				Maj	Prt	Min	Obs	Info	
383E0000 hex	Vibration Detection Warning	Vibration was detected.	<ul style="list-style-type: none"> The gain or inertial ratio setting is not suitable. 				√		page A-165
74800000 hex	Command Warning	A command could not be executed.	<ul style="list-style-type: none"> The absolute multi-rotation counter was cleared when the Servo was not OFF when using an absolute encoder for semi-closed control. A forced brake operation request was sent while the Servo was ON. A Switch ON command was sent when the main power was OFF. (When 3508 hex = 0) An Enable Operation command was sent to request turning ON the Servo when the Servomotor was operating at 30 r/min or higher. A latch operation was started under the following conditions. <ul style="list-style-type: none"> An absolute external encoder was used and phase Z was selected as the trigger for fully-closed control. The absolute multi-rotation data was being cleared or the Config operation was being performed. The Statusword (6041 hex) bit 09 (remote) was 0 (local). An operation command is given in the prohibited direction after the motor made an immediate stop due to a drive prohibition input. 				√		page A-166
84B00000 hex	EtherCAT Communications Warning	An EtherCAT communications error occurred one or more times.	<ul style="list-style-type: none"> The EtherCAT communications cable is disconnected or broken. Noise 				√		page A-167

A-3-2 Error Description

This section describes errors.

Controller Error Descriptions

The items that are used to describe individual errors (events) are described in the following copy of an error table.

Event name	Gives the name of the error (event).		Event code	Gives the code of the error (event).	
Meaning	Gives a short description of the error (event).				
Source	Gives the source of the error (event).		Source details	Gives details on the source of the error.	Detection timing Tells when the error is detected.
Error attributes	Level	Tells the influence on control.*1	Recovery	Gives the recovery method.*2	Log category Tells which log the error is saved in.*3
Effects	User program	Tells what will happen to execution of the user program.*4	Operation	Provides special information on the operation that results from the error (event).	
Indicators	Gives the status of the built-in EtherNet/IP port and built-in EtherCAT port indicators. Indicator status is given only for errors in the EtherCAT Master Function Module and the EtherNet/IP Function Module.				
System-defined variables	Variable	Data type		Name	
	Lists the variable names, data types, and meanings for system-defined variables that provide direct error notification, that are directly affected by the error, or that contain settings that cause the error.				
Cause and correction	Assumed cause		Remedy		Prevention
	Lists the possible causes, remedies, and preventive measures for the error (event).				
Attached information	Provides the additional information that is displayed by the Sysmac Studio or an NS-series PT.				
Precautions/Remarks	Provides precautions, restrictions, and supplemental information.				

*1 One of the following:

- Major fault: Major fault level
- Partial fault: Partial fault level
- Minor fault: Minor fault level
- Observation Information

*2 One of the following:

- Automatic recovery: Normal status is restored automatically when the cause of the error is removed.
- Error reset: Normal status is restored when the error is reset after the cause of the error is removed.
- Cycle the power supply: Normal status is restored when the power supply to the Controller is turned OFF and then back ON after the cause of the error is removed.
- Controller reset: Normal status is restored when the Controller is reset after the cause of the error is removed.
- Depends on cause: The recovery method depends on the cause of the error.

*3 One of the following:

- System: System event log
- Access: Access event log

*4 One of the following:

- Continues: Execution of the user program will continue.
- Stops: Execution of the user program stops.
- Starts: Execution of the user program starts.

Error Descriptions

The following table describes the error codes that are output to *ErrorID* when errors occur in execution of the instructions. The upper four digits of the event codes that are given in the following table are output as the error code to *ErrorID*.

Event name	Control Power Supply Undervoltage		Event code	04A80000 hex		
Meaning	The voltage between the positive and negative terminals in the control power supply converter dropped below the specified value.					
Source	EtherCAT Master Function Module		Source details	Slave	Detection timing	Continuously
Error attributes	Level	Minor fault	Recovery	Error reset (after resetting slave errors)	Log category	System
Effects	User program	Continues.	Operation	Power drive circuit is OFF for relevant slave.		
Indicators	EtherCAT NET RUN		EtherCAT NET ERR		EtherCAT LINK/ACT	
	---		---		---	
System-defined variables	Variable	Data type		Name		
	None		---		---	
Cause and correction	Assumed cause		Remedy		Prevention	
	Power supply undervoltage. Or, the power supply voltage dropped because there was inrush current when the main power supply was turned ON.		Increase the power supply capacity.		None	
	A momentary power interruption occurred.		Review the power supply conditions and prevent momentary power interruption.		Make sure that the power supply conditions prevent momentary power interruption.	
	The Servo Drive failed.		Replace the Servo Drive.		None	
Attached information	None					
Precautions/Remarks	“11” is displayed on the Servo Drive front panel and F011 is given as the AlarmCode (4001 hex)					

Event name	Overvoltage		Event code	04A90000 hex		
Meaning	The power supply voltage exceeded the allowable input voltage range.					
Source	EtherCAT Master Function Module		Source details	Slave	Detection timing	Continuously
Error attributes	Level	Minor fault	Recovery	Error reset (after resetting slave errors)	Log category	System
Effects	User program	Continues.	Operation	Power drive circuit is OFF for relevant slave.		
Indicators	EtherCAT NET RUN		EtherCAT NET ERR		EtherCAT LINK/ACT	
	---		---		---	
System-defined variables	Variable		Data type		Name	
	None		---		---	
Cause and correction	Assumed cause		Remedy		Prevention	
	The voltage between the positive and negative terminals in the control power supply converter exceeded the specified value.		Input the correct voltage.		Input the correct voltage.	
	The voltage was suddenly increased by the phase advance capacitor or the uninterruptible power supply (UPS).		Remove the phase-advancing capacitor or UPS.		Do not use a phase-advancing capacitor or UPS.	
	The Regeneration Resistor wiring is broken.		Measure the resistance of the external resistor between the B1 and B2 terminals on the Servo Drive. If the resistance is infinite, the wiring is broken. Replace the external resistor.		None	
	The External Regeneration Resistor is not suitable.		Change the Regeneration Resistor based on the specified regeneration resistance and the calculated power (W).		Determine the Regeneration Resistor based on the specified regeneration resistance and the calculated power (W).	
	The Servo Drive failed.		Replace the Servo Drive.		None	
Attached information	None					
Precautions/Remarks	"12" is displayed on the Servo Drive front panel and F012 is given as the AlarmCode (4001 hex)					

Event name	Main Circuit Power Supply Undervoltage (Undervoltage between positive and negative terminals)		Event code	04AA0000 hex		
Meaning	If the Undervoltage Error Selection (3508 hex) is set to 1, a momentary power interruption occurred between L1 and L3 for longer than the value specified for the Momentary Hold Time. The voltage between the positive and negative terminals in the main power supply converter dropped below the specified value while the Servo was ON.					
Source	EtherCAT Master Function Module		Source details	Slave	Detection timing	While power is supplied to motor
Error attributes	Level	Minor fault	Recovery	Error reset (after resetting slave errors)	Log category	System
Effects	User program	Continues.	Operation	Power drive circuit is OFF for relevant slave.		
Indicators	EtherCAT NET RUN		EtherCAT NET ERR		EtherCAT LINK/ACT	
	---		---		---	
System-defined variables	Variable		Data type		Name	
	None		---		---	
Cause and correction	Assumed cause		Remedy		Prevention	
	Insufficient power supply capacity		Increase the power supply capacity.		None	
	The electromagnetic contactor in the main circuit power supply was tripped.		Eliminate the cause of the failure of the electromagnetic contactor on the main circuit power supply, and then turn ON the power again.		Check the wiring of the main circuit power supply.	
	A momentary power interruption occurred.		Review the power supply conditions and prevent momentary power interruption. Alternatively, increase the Momentary Hold Time (3509 hex) setting.		Make sure that the power supply conditions prevent momentary power interruption.	
	A Servo Drive with 3-phase input specifications was operated with a single-phase power supply.		Make sure that the phases of the power supply are set correctly before you connect them.		Make sure that the phases of the power supply are set correctly before you connect them.	
	The Servo Drive failed.		Replace the Servo Drive.		None	
Attached information	None					
Precautions/Remarks	"13" is displayed on the Servo Drive front panel and F013 is given as the AlarmCode (4001 hex)					

Event name	Main Circuit Power Supply Undervoltage (AC Cutoff Detected)		Event code	04AB0000 hex		
Meaning	If the Undervoltage Error Selection (3508 hex) is set to 1, a momentary power interruption occurred between L1 and L3 for longer than the value specified for the Momentary Hold Time. The voltage between the positive and negative terminals in the main power supply converter dropped below the specified value while the Servo was ON.					
Source	EtherCAT Master Function Module		Source details	Slave	Detection timing	While power is supplied to motor
Error attributes	Level	Minor fault	Recovery	Error reset (after resetting slave errors)	Log category	System
Effects	User program	Continues.	Operation	Power drive circuit is OFF for relevant slave.		
Indicators	EtherCAT NET RUN		EtherCAT NET ERR		EtherCAT LINK/ACT	
	---		---		---	
System-defined variables	Variable		Data type		Name	
	None		---		---	
Cause and correction	Assumed cause		Remedy		Prevention	
	Insufficient power supply capacity		Increase the power supply capacity.		None	
	The electromagnetic contactor in the main circuit power supply was tripped.		Eliminate the cause of the failure of the electromagnetic contactor on the main circuit power supply, and then turn ON the power again.		Check the wiring of the main circuit power supply.	
	A momentary power interruption occurred.		Review the power supply conditions and prevent momentary power interruption. Alternatively, increase the Momentary Hold Time (3509 hex) setting.		Make sure that the power supply conditions prevent momentary power interruption.	
	A Servo Drive with 3-phase input specifications was operated with a single-phase power supply.		Make sure that the phases of the power supply are set correctly before you connect them.		Make sure that the phases of the power supply are set correctly before you connect them.	
	The Servo Drive failed.		Replace the Servo Drive.		None	
Attached information	None					
Precautions/Remarks	“13” is displayed on the Servo Drive front panel and F113 is given as the AlarmCode (4001 hex)					

Event name	Overcurrent		Event code	04AC0000 hex		
Meaning	The current flowing through the converter exceeded the specified value.					
Source	EtherCAT Master Function Module		Source details	Slave	Detection timing	Continuously
Error attributes	Level	Minor fault	Recovery	Error reset (after cycling slave power)	Log category	System
Effects	User program	Continues.	Operation	Power drive circuit is OFF for relevant slave.		
Indicators	EtherCAT NET RUN		EtherCAT NET ERR		EtherCAT LINK/ACT	
	---		---		---	
System-defined variables	Variable		Data type		Name	
	None		---		---	
Cause and correction	Assumed cause		Remedy		Prevention	
	A short-circuit, line-to-ground fault, contact failure, or insulation failure occurred on the U, V, or W motor line.		If there is a short-circuit, line-to-ground fault, or contact failure on the U, V, or W motor line, correct the connections. If the insulation resistance between the U, V, or W motor line and the ground line has failed, replace the motor.		Confirm that the U, V, and W motor lines are connected correctly.	
	The Servo Drive failed.		Disconnect the motor lines and turn ON the Servo. If this error occurs immediately, replace the Servo Drive.		None	
	The relay for the dynamic brake has been welded due to frequent Servo ON/OFF operations.		Replace the Servo Drive.		Do not start and stop operation by frequently switching the Servo ON/OFF.	
	Motor windings are burned out.		Check the balance of the resistance between the lines of the Servomotor. If resistance is unbalanced, replace the Servomotor.		Do not apply excessive load on the motor.	
	The Servomotor is not suitable for the Servo Drive.		Check the model (capacity) of the Servomotor and the Servo Drive on the nameplates. Replace the Servomotor with a Servomotor that matches the Servo Drive.		Use a Servomotor that matches the Servo Drive.	
	The command input timing is the same as or earlier than the Servo ON timing.		Wait at least 100 ms after the Servo has been turned ON, then input commands.		Wait at least 100 ms after the Servo has been turned ON, then input commands.	
Attached information	None					
Precautions/Remarks	“14” is displayed on the Servo Drive front panel and F014 is given as the AlarmCode (4001 hex)					

Event name	IPM Error		Event code	04AD0000 hex		
Meaning	The current flowing through the converter exceeded the specified value.					
Source	EtherCAT Master Function Module		Source details	Slave	Detection timing	Continuously
Error attributes	Level	Minor fault	Recovery	Error reset (after cycling slave power)	Log category	System
Effects	User program	Continues.	Operation	Power drive circuit is OFF for relevant slave.		
Indicators	EtherCAT NET RUN		EtherCAT NET ERR		EtherCAT LINK/ACT	
	---		---		---	
System-defined variables	Variable		Data type		Name	
	None		---		---	
Cause and correction	Assumed cause		Remedy		Prevention	
	A short-circuit, line-to-ground fault, contact failure, or insulation failure occurred on the U, V, or W motor line.		If there is a short-circuit, line-to-ground fault, or contact failure on the U, V, or W motor line, correct the connections. If the insulation resistance between the U, V, or W motor line and the ground line has failed, replace the motor.		Confirm that the U, V, and W motor lines are connected correctly.	
	The Servo Drive failed.		Disconnect the motor lines and turn ON the Servo. If this error occurs immediately, replace the Servo Drive.		None	
	The relay for the dynamic brake has been welded due to frequent Servo ON/OFF operations.		Replace the Servo Drive.		Do not start and stop operation by frequently switching the Servo ON/OFF.	
	Motor windings are burned out.		Check the balance of the resistance between the lines of the Servomotor. If resistance is unbalanced, replace the Servomotor.		Do not apply excessive load on the motor.	
	The Servomotor is not suitable for the Servo Drive.		Check the model (capacity) of the Servomotor and the Servo Drive on the nameplates. Replace the Servomotor with a Servomotor that matches the Servo Drive.		Use a Servomotor that matches the Servo Drive.	
	The command input timing is the same as or earlier than the Servo ON timing.		Wait at least 100 ms after the Servo has been turned ON, then input commands.		Wait at least 100 ms after the Servo has been turned ON, then input commands.	
Attached information	None					
Precautions/Remarks	“14” is displayed on the Servo Drive front panel and F114 is given as the AlarmCode (4001 hex)					

Event name	Regeneration Tr Error			Event code	04AE0000 hex	
Meaning	The Servo Drive regeneration drive Tr is faulty.					
Source	EtherCAT Master Function Module		Source details	Slave	Detection timing	While power is supplied to motor
Error attributes	Level	Minor fault	Recovery	Error reset (after cycling slave power)	Log category	System
Effects	User program	Continues.	Operation	Power drive circuit is OFF for relevant slave.		
Indicators	EtherCAT NET RUN		EtherCAT NET ERR		EtherCAT LINK/ACT	
	---		---		---	
System-defined variables	Variable		Data type		Name	
	None		---		---	
Cause and correction	Assumed cause		Remedy		Prevention	
	The Servo Drive regeneration drive Tr is faulty.		Replace the Servo Drive.		None	
Attached information	None					
Precautions/Remarks	"18" is displayed on the Servo Drive front panel and F118 is given as the AlarmCode (4001 hex)					

Event name	Encoder Phase-Z Error			Event code	04AF0000 hex	
Meaning	A missing serial incremental encoder phase-Z pulse was detected.					
Source	EtherCAT Master Function Module		Source details	Slave	Detection timing	Continuously
Error attributes	Level	Minor fault	Recovery	Error reset (after cycling slave power)	Log category	System
Effects	User program	Continues.	Operation	Power drive circuit is OFF for relevant slave.		
Indicators	EtherCAT NET RUN		EtherCAT NET ERR		EtherCAT LINK/ACT	
	---		---		---	
System-defined variables	Variable		Data type		Name	
	None		---		---	
Cause and correction	Assumed cause		Remedy		Prevention	
	The encoder is faulty.		Replace the Servomotor.		None	
Attached information	None					
Precautions/Remarks	"48" is displayed on the Servo Drive front panel and F048 is given as the AlarmCode (4001 hex).					

Event name	Encoder CTS Signal Error			Event code	04B00000 hex	
Meaning	A missing serial incremental encoder CTS signal logic error was detected.					
Source	EtherCAT Master Function Module		Source details	Slave	Detection timing	Continuously
Error attributes	Level	Minor fault	Recovery	Error reset (after cycling slave power supply)	Log category	System
Effects	User program	Continues.	Operation	Power drive circuit is OFF for relevant slave.		
Indicators	EtherCAT NET RUN		EtherCAT NET ERR		EtherCAT LINK/ACT	
	---		---		---	
System-defined variables	Variable		Data type		Name	
	None		---		---	
Cause and correction	Assumed cause		Remedy		Prevention	
	The encoder is faulty.		Replace the Servomotor.		None	
Attached information	None					
Precautions/Remarks	"49" is displayed on the Servo Drive front panel and F049 is given as the AlarmCode (4001 hex).					

Event name	Node Address Setting Error			Event code	04B10000 hex	
Meaning	The node address that was read from the rotary switches was not between 00 and 99.					
Source	EtherCAT Master Function Module		Source details	Slave	Detection timing	When establishing communications after turning ON power to the slave
Error attributes	Level	Minor fault	Recovery	Error reset (after cycling slave power)	Log category	System
Effects	User program	Continues.	Operation	Power drive circuit is OFF for relevant slave.		
Indicators	EtherCAT NET RUN		EtherCAT NET ERR		EtherCAT LINK/ACT	
	---		---		---	
System-defined variables	Variable		Data type		Name	
	None		---		---	
Cause and correction	Assumed cause		Remedy		Prevention	
	The Servo Drive failed.		Replace the Servo Drive.		None	
Attached information	None					
Precautions/Remarks	"88" is displayed on the Servo Drive front panel and F088 is given as the AlarmCode (4001 hex).					

Event name	Encoder Communications Disconnection Error		Event code	08080000 hex		
Meaning	A disconnection was detected because communications between the encoder and the Servo Drive were stopped more frequently than the specified value.					
Source	EtherCAT Master Function Module		Source details	Slave	Detection timing	Continuously
Error attributes	Level	Minor fault	Recovery	Error reset (after cycling slave power)	Log category	System
Effects	User program	Continues.	Operation	Power drive circuit is OFF for relevant slave.		
Indicators	EtherCAT NET RUN		EtherCAT NET ERR		EtherCAT LINK/ACT	
	---		---		---	
System-defined variables	Variable		Data type		Name	
	None		---		---	
Cause and correction	Assumed cause		Remedy		Prevention	
	The encoder is not wired correctly.		Wire the encoder correctly as shown in the wiring diagram. Correct the connector pin connections.		Wire the encoder correctly as shown in the wiring diagram. Connect the connector pins correctly.	
Attached information	None					
Precautions/Remarks	“21” is displayed on the Servo Drive front panel and F021 is given as the AlarmCode (4001 hex)					

Event name	Encoder Communications Error		Event code	08090000 hex		
Meaning	There is a communications error for the encoder.					
Source	EtherCAT Master Function Module		Source details	Slave	Detection timing	Continuously
Error attributes	Level	Minor fault	Recovery	Error reset (after cycling slave power)	Log category	System
Effects	User program	Continues.	Operation	Power drive circuit is OFF for relevant slave.		
Indicators	EtherCAT NET RUN		EtherCAT NET ERR		EtherCAT LINK/ACT	
	---		---		---	
System-defined variables	Variable		Data type		Name	
	None		---		---	
Cause and correction	Assumed cause		Remedy		Prevention	
	The power supply voltage of the encoder is low.		Provide the required encoder power supply voltage of 5 VDC \pm 5% (4.75 to 5.25 V). Be careful especially of voltage drop when the encode cable is long.		Provide the required encoder power supply voltage of 5 VDC \pm 5% (4.75 to 5.25 V). Be careful especially of voltage drop when the encode cable is long.	
	Noise		If the Servomotor cable and the encoder cable are bundled together, separate them. Connect the shield to FG.		If the Servomotor cable and the encoder cable are bundled together, separate them. Connect the shield to FG.	
Attached information	None					
Precautions/Remarks	“21” is displayed on the Servo Drive front panel and F121 is given as the AlarmCode (4001 hex)					

Event name	Encoder Communications Data Error		Event code	080A0000 hex		
Meaning	There is an error in the communications data of the encoder.					
Source	EtherCAT Master Function Module		Source details	Slave	Detection timing	Continuously
Error attributes	Level	Minor fault	Recovery	Error reset (after cycling slave power)	Log category	System
Effects	User program	Continues.	Operation	Power drive circuit is OFF for relevant slave.		
Indicators	EtherCAT NET RUN		EtherCAT NET ERR		EtherCAT LINK/ACT	
	---		---		---	
System-defined variables	Variable		Data type		Name	
	None		---		---	
Cause and correction	Assumed cause		Remedy		Prevention	
	The power supply voltage of the encoder is low.		Provide the required encoder power supply voltage of 5 VDC \pm 5% (4.75 to 5.25 V). Be careful especially of voltage drop when the encode cable is long.		Provide the required encoder power supply voltage of 5 VDC \pm 5% (4.75 to 5.25 V). Be careful especially of voltage drop when the encode cable is long.	
	Noise		If the Servomotor cable and the encoder cable are bundled together, separate them. Connect the shield to FG.		If the Servomotor cable and the encoder cable are bundled together, separate them. Connect the shield to FG.	
Attached information	None					
Precautions/Remarks	"23" is displayed on the Servo Drive front panel and F023 is given as the AlarmCode (4001 hex)					

Event name	Safety Input Error		Event code	080B0000 hex		
Meaning	At least one of the input photocouplers for safety inputs 1 and 2 turned OFF.					
Source	EtherCAT Master Function Module		Source details	Slave	Detection timing	Continuously
Error attributes	Level	Minor fault	Recovery	Error reset (after resetting slave errors)	Log category	System
Effects	User program	Continues.	Operation	Power drive circuit is OFF for relevant slave.		
Indicators	EtherCAT NET RUN		EtherCAT NET ERR		EtherCAT LINK/ACT	
	---		---		---	
System-defined variables	Variable		Data type		Name	
	None		---		---	
Cause and correction	Assumed cause		Remedy		Prevention	
	The cable is disconnected or broken.		Reconnect the input wiring for safety inputs 1 and 2. If the cable is broken, replace it.		Reconnect the input wiring for safety inputs 1 and 2.	
Attached information	None					
Precautions/Remarks	"30" is displayed on the Servo Drive front panel and F030 is given as the AlarmCode (4001 hex).					

Event name	External Encoder Connection Error			Event code	080C0000 hex	
Meaning	A disconnection was detected because communications between the external encoder and the Servo Drive were stopped more frequently than the specified value.					
Source	EtherCAT Master Function Module		Source details	Slave	Detection timing	Continuously
Error attributes	Level	Minor fault	Recovery	Error reset (after cycling slave power)	Log category	System
Effects	User program	Continues.	Operation	Power drive circuit is OFF for relevant slave.		
Indicators	EtherCAT NET RUN		EtherCAT NET ERR		EtherCAT LINK/ACT	
	---		---		---	
System-defined variables	Variable		Data type		Name	
	None		---		---	
Cause and correction	Assumed cause		Remedy		Prevention	
	The wiring is incorrect.		Wire the external encoder correctly as shown in the wiring diagram. Correct the connector pin connections.		Wire the external encoder correctly as shown in the wiring diagram. Connect the connector pins correctly.	
Attached information	None					
Precautions/Remarks	“50” is displayed on the Servo Drive front panel and F050 is given as the AlarmCode (4001 hex).					

Event name	External Encoder Communications Data Error			Event code	080D0000 hex	
Meaning	There was a communications error in data from the external encoder.					
Source	EtherCAT Master Function Module		Source details	Slave	Detection timing	Continuously
Error attributes	Level	Minor fault	Recovery	Error reset (after cycling slave power)	Log category	System
Effects	User program	Continues.	Operation	Power drive circuit is OFF for relevant slave.		
Indicators	EtherCAT NET RUN		EtherCAT NET ERR		EtherCAT LINK/ACT	
	---		---		---	
System-defined variables	Variable		Data type		Name	
	None		---		---	
Cause and correction	Assumed cause		Remedy		Prevention	
	There is insufficient external encoder power supply voltage.		Provide the required external encoder power supply voltage 5 VDC ±5% (4.75 to 5.25 V).		Provide the required external encoder power supply voltage 5 VDC ±5% (4.75 to 5.25 V).	
	Noise		If the Servomotor cable and the external encoder cable are bundled together, separate them. Connect the shield to FG.		If the Servomotor cable and the external encoder cable are bundled together, separate them. Connect the shield to FG.	
Attached information	None					
Precautions/Remarks	“50” is displayed on the Servo Drive front panel and F150 is given as the AlarmCode (4001 hex).					

Event name	External Encoder Status Error 0		Event code	080E0000 hex		
Meaning	Bit 00 of the external encoder error code (ALMC) was set to 1.					
Source	EtherCAT Master Function Module		Source details	Slave	Detection timing	Continuously
Error attributes	Level	Minor fault	Recovery	Error reset (after cycling slave power)	Log category	System
Effects	User program	Continues.	Operation	Power drive circuit is OFF for relevant slave.		
Indicators	EtherCAT NET RUN		EtherCAT NET ERR		EtherCAT LINK/ACT	
	---		---		---	
System-defined variables	Variable		Data type		Name	
	None		---		---	
Cause and correction	Assumed cause		Remedy		Prevention	
	Bit 00 of the external scale error code (ALMC) was set to 1.		Check the external encoder specifications and take suitable corrective actions.		Take preventative actions according to the external encoder specifications.	
Attached information	None					
Precautions/Remarks	"51" is displayed on the Servo Drive front panel and F051 is given as the AlarmCode (4001 hex).					

Event name	External Encoder Status Error 1		Event code	080F0000 hex		
Meaning	Bit 01 of the external encoder error code (ALMC) was set to 1.					
Source	EtherCAT Master Function Module		Source details	Slave	Detection timing	Continuously
Error attributes	Level	Minor fault	Recovery	Error reset (after cycling slave power)	Log category	System
Effects	User program	Continues.	Operation	Power drive circuit is OFF for relevant slave.		
Indicators	EtherCAT NET RUN		EtherCAT NET ERR		EtherCAT LINK/ACT	
	---		---		---	
System-defined variables	Variable		Data type		Name	
	None		---		---	
Cause and correction	Assumed cause		Remedy		Prevention	
	Bit 01 of the external encoder error code (ALMC) was set to 1.		Check the external encoder specifications and take suitable corrective actions.		Take preventative actions according to the external encoder specifications.	
Attached information	None					
Precautions/Remarks	"51" is displayed on the Servo Drive front panel and F151 is given as the AlarmCode (4001 hex).					

Event name	External Encoder Status Error 2			Event code	08100000 hex	
Meaning	Bit 02 of the external encoder error code (ALMC) was set to 1.					
Source	EtherCAT Master Function Module		Source details	Slave	Detection timing	Continuously
Error attributes	Level	Minor fault	Recovery	Error reset (after cycling slave power)	Log category	System
Effects	User program	Continues.	Operation	Power drive circuit is OFF for relevant slave.		
Indicators	EtherCAT NET RUN		EtherCAT NET ERR		EtherCAT LINK/ACT	
	---		---		---	
System-defined variables	Variable		Data type		Name	
	None		---		---	
Cause and correction	Assumed cause		Remedy		Prevention	
	Bit 02 of the external encoder error code (ALMC) was set to 1.		Check the external encoder specifications and take suitable corrective actions.		Take preventative actions according to the external encoder specifications.	
Attached information	None					
Precautions/Remarks	"51" is displayed on the Servo Drive front panel and F251 is given as the AlarmCode (4001 hex).					

Event name	External Encoder Status Error 3			Event code	08110000 hex	
Meaning	Bit 03 of the external encoder error code (ALMC) was set to 1.					
Source	EtherCAT Master Function Module		Source details	Slave	Detection timing	Continuously
Error attributes	Level	Minor fault	Recovery	Error reset (after cycling slave power)	Log category	System
Effects	User program	Continues.	Operation	Power drive circuit is OFF for relevant slave.		
Indicators	EtherCAT NET RUN		EtherCAT NET ERR		EtherCAT LINK/ACT	
	---		---		---	
System-defined variables	Variable		Data type		Name	
	None		---		---	
Cause and correction	Assumed cause		Remedy		Prevention	
	Bit 03 of the external encoder error code (ALMC) was set to 1.		Check the external encoder specifications and take suitable corrective actions.		Take preventative actions according to the external encoder specifications.	
Attached information	None					
Precautions/Remarks	"51" is displayed on the Servo Drive front panel and F351 is given as the AlarmCode (4001 hex).					

Event name	External Encoder Status Error 4		Event code	08120000 hex		
Meaning	Bit 04 of the external encoder error code (ALMC) was set to 1.					
Source	EtherCAT Master Function Module		Source details	Slave	Detection timing	Continuously
Error attributes	Level	Minor fault	Recovery	Error reset (after cycling slave power)	Log category	System
Effects	User program	Continues.	Operation	Power drive circuit is OFF for relevant slave.		
Indicators	EtherCAT NET RUN		EtherCAT NET ERR		EtherCAT LINK/ACT	
	---		---		---	
System-defined variables	Variable		Data type		Name	
	None		---		---	
Cause and correction	Assumed cause		Remedy		Prevention	
	Bit 04 of the external encoder error code (ALMC) was set to 1.		Check the external encoder specifications and take suitable corrective actions.		Take preventative actions according to the external encoder specifications.	
Attached information	None					
Precautions/Remarks	"51" is displayed on the Servo Drive front panel and F451 is given as the AlarmCode (4001 hex).					

Event name	External Encoder Status Error 5		Event code	08130000 hex		
Meaning	Bit 05 of the external encoder error code (ALMC) was set to 1.					
Source	EtherCAT Master Function Module		Source details	Slave	Detection timing	Continuously
Error attributes	Level	Minor fault	Recovery	Error reset (after cycling slave power)	Log category	System
Effects	User program	Continues.	Operation	Power drive circuit is OFF for relevant slave.		
Indicators	EtherCAT NET RUN		EtherCAT NET ERR		EtherCAT LINK/ACT	
	---		---		---	
System-defined variables	Variable		Data type		Name	
	None		---		---	
Cause and correction	Assumed cause		Remedy		Prevention	
	Bit 05 of the external encoder error code (ALMC) was set to 1.		Check the external encoder specifications and take suitable corrective actions.		Take preventative actions according to the external encoder specifications.	
Attached information	None					
Precautions/Remarks	"51" is displayed on the Servo Drive front panel and F551 is given as the AlarmCode (4001 hex).					

Event name	Phase-A Connection Error			Event code	08140000 hex	
Meaning	An error such as broken wiring was detected in the external encoder phase-A connection.					
Source	EtherCAT Master Function Module		Source details	Slave	Detection timing	Continuously
Error attributes	Level	Minor fault	Recovery	Error reset (after cycling slave power)	Log category	System
Effects	User program	Continues.	Operation	Power drive circuit is OFF for relevant slave.		
Indicators	EtherCAT NET RUN		EtherCAT NET ERR		EtherCAT LINK/ACT	
	---		---		---	
System-defined variables	Variable		Data type		Name	
	None		---		---	
Cause and correction	Assumed cause		Remedy		Prevention	
	An error such as broken wiring was detected in the external encoder phase-A connection.		Wire phase A of the external encoder correctly as shown in the wiring diagram. If the cable is broken, replace it.		Wire phase A of the external encoder correctly as shown in the wiring diagram.	
Attached information	None					
Precautions/Remarks	"55" is displayed on the Servo Drive front panel and F055 is given as the AlarmCode (4001 hex).					

Event name	Phase-B Connection Error			Event code	08150000 hex	
Meaning	An error such as broken wiring was detected in the external encoder phase-B connection.					
Source	EtherCAT Master Function Module		Source details	Slave	Detection timing	Continuously
Error attributes	Level	Minor fault	Recovery	Error reset (after cycling slave power)	Log category	System
Effects	User program	Continues.	Operation	Power drive circuit is OFF for relevant slave.		
Indicators	EtherCAT NET RUN		EtherCAT NET ERR		EtherCAT LINK/ACT	
	---		---		---	
System-defined variables	Variable		Data type		Name	
	None		---		---	
Cause and correction	Assumed cause		Remedy		Prevention	
	An error such as broken wiring was detected in the external encoder phase-B connection.		Wire phase B of the external encoder correctly as shown in the wiring diagram. If the cable is broken, replace it.		Wire phase B of the external encoder correctly as shown in the wiring diagram.	
Attached information	None					
Precautions/Remarks	"55" is displayed on the Servo Drive front panel and F155 is given as the AlarmCode (4001 hex).					

Event name	Phase-Z Connection Error			Event code	08160000 hex	
Meaning	An error such as broken wiring was detected in the external encoder phase-Z connection.					
Source	EtherCAT Master Function Module		Source details	Slave	Detection timing	Continuously
Error attributes	Level	Minor fault	Recovery	Error reset (after cycling slave power)	Log category	System
Effects	User program	Continues.	Operation	Power drive circuit is OFF for relevant slave.		
Indicators	EtherCAT NET RUN		EtherCAT NET ERR		EtherCAT LINK/ACT	
	---		---		---	
System-defined variables	Variable		Data type		Name	
	None		---		---	
Cause and correction	Assumed cause		Remedy		Prevention	
	An error such as broken wiring was detected in the external encoder phase-Z connection.		Wire phase Z of the external encoder correctly as shown in the wiring diagram. If the cable is broken, replace it.		Wire phase Z of the external encoder correctly as shown in the wiring diagram.	
Attached information	None					
Precautions/Remarks	"55" is displayed on the Servo Drive front panel and F255 is given as the AlarmCode (4001 hex).					

Event name	Encoder Data Restoration Error			Event code	08170000 hex	
Meaning	Initialization of internal position data was not processed correctly in Semi-closed Control Mode and Absolute Value Mode.					
Source	EtherCAT Master Function Module		Source details	Slave	Detection timing	Continuously
Error attributes	Level	Minor fault	Recovery	Error reset (after cycling slave power)	Log category	System
Effects	User program	Continues.	Operation	Power drive circuit is OFF for relevant slave.		
Indicators	EtherCAT NET RUN		EtherCAT NET ERR		EtherCAT LINK/ACT	
	---		---		---	
System-defined variables	Variable		Data type		Name	
	None		---		---	
Cause and correction	Assumed cause		Remedy		Prevention	
	There is insufficient power supply voltage for the encoder.		Provide the required encoder power supply voltage of 5 VDC \pm 5% (4.75 to 5.25 V).		Provide the required encoder power supply voltage of 5 VDC \pm 5% (4.75 to 5.25 V).	
	Noise is entering on the encoder line.		If the Servomotor cable and the encoder cable are bundled together, separate them. Connect the shield to FG.		If the Servomotor cable and the encoder cable are bundled together, separate them. Connect the shield to FG.	
Attached information	None					
Precautions/Remarks	"92" is displayed on the Servo Drive front panel and F092 is given as the AlarmCode (4001 hex).					

Event name	External Encoder Data Restoration Error		Event code	08180000 hex		
Meaning	Initialization of internal position data was not processed correctly in Fully-closed Control Mode and Absolute Value Mode.					
Source	EtherCAT Master Function Module		Source details	Slave	Detection timing	Continuously
Error attributes	Level	Minor fault	Recovery	Error reset (after cycling slave power)	Log category	System
Effects	User program	Continues.	Operation	Power drive circuit is OFF for relevant slave.		
Indicators	EtherCAT NET RUN		EtherCAT NET ERR		EtherCAT LINK/ACT	
	---		---		---	
System-defined variables	Variable		Data type		Name	
	None		---		---	
Cause and correction	Assumed cause		Remedy		Prevention	
	There is insufficient power supply voltage for the external encoder.		Provide the required external encoder power supply voltage 5 VDC \pm 5% (4.75 to 5.25 V).		Provide the required external encoder power supply voltage 5 VDC \pm 5% (4.75 to 5.25 V).	
	Noise is entering on the external encoder line.		If the Servomotor cable and the external encoder cable are bundled together, separate them. Connect the shield to FG.		If the Servomotor cable and the external encoder cable are bundled together, separate them. Connect the shield to FG.	
Attached information	None					
Precautions/Remarks	"92" is displayed on the Servo Drive front panel and F192 is given as the AlarmCode (4001 hex).					

Event name	Object Error		Event code	14A80000 hex		
Meaning	The object area data in non-volatile memory is corrupted.					
Source	EtherCAT Master Function Module		Source details	Slave	Detection timing	When establishing communications after turning ON power to the slave
Error attributes	Level	Minor fault	Recovery	Error reset (after cycling slave power)	Log category	System
Effects	User program	Continues.	Operation	Power drive circuit is OFF for relevant slave.		
Indicators	EtherCAT NET RUN		EtherCAT NET ERR		EtherCAT LINK/ACT	
	---		---		---	
System-defined variables	Variable		Data type		Name	
	None		---		---	
Cause and correction	Assumed cause		Remedy		Prevention	
	Noise		Reset all of the objects. Implement noise countermeasures.		Reset all of the objects. Implement noise countermeasures.	
	Non-volatile memory failure		If the error persists, replace the Servo Drive.		None	
Attached information	None					
Precautions/Remarks	"36" is displayed on the Servo Drive front panel and F036 is given as the AlarmCode (4001 hex).					

Event name	Object Error		Event code	14A90000 hex		
Meaning	The object area data in non-volatile memory is corrupted.					
Source	EtherCAT Master Function Module		Source details	Slave	Detection timing	When establishing communications after turning ON power to the slave
Error attributes	Level	Minor fault	Recovery	Error reset (after cycling slave power)	Log category	System
Effects	User program	Continues.	Operation	Power drive circuit is OFF for relevant slave.		
Indicators	EtherCAT NET RUN		EtherCAT NET ERR		EtherCAT LINK/ACT	
	---		---		---	
System-defined variables	Variable		Data type		Name	
	None		---		---	
Cause and correction	Assumed cause		Remedy		Prevention	
	Noise		Reset all of the objects. Implement noise countermeasures.		Reset all of the objects. Implement noise countermeasures.	
	Non-volatile memory failure		If the error persists, replace the Servo Drive.		None	
Attached information	None					
Precautions/Remarks	"36" is displayed on the Servo Drive front panel and F136 is given as the AlarmCode (4001 hex).					

Event name	Object Error		Event code	14AA0000 hex		
Meaning	The object area data in non-volatile memory is corrupted.					
Source	EtherCAT Master Function Module		Source details	Slave	Detection timing	When establishing communications after turning ON power to the slave
Error attributes	Level	Minor fault	Recovery	Error reset (after cycling slave power)	Log category	System
Effects	User program	Continues.	Operation	Power drive circuit is OFF for relevant slave.		
Indicators	EtherCAT NET RUN		EtherCAT NET ERR		EtherCAT LINK/ACT	
	---		---		---	
System-defined variables	Variable		Data type		Name	
	None		---		---	
Cause and correction	Assumed cause		Remedy		Prevention	
	Noise		Reset all of the objects. Implement noise countermeasures.		Reset all of the objects. Implement noise countermeasures.	
	Non-volatile memory failure		If the error persists, replace the Servo Drive.		None	
Attached information	None					
Precautions/Remarks	"36" is displayed on the Servo Drive front panel and F236 is given as the AlarmCode (4001 hex).					

Event name	Object Corrupted			Event code	14AB0000 hex	
Meaning	The checksum data in non-volatile memory is corrupted.					
Source	EtherCAT Master Function Module		Source details	Slave	Detection timing	When establishing communications after turning ON power to the slave
Error attributes	Level	Minor fault	Recovery	Error reset (after cycling slave power)	Log category	System
Effects	User program	Continues.	Operation	Power drive circuit is OFF for relevant slave.		
Indicators	EtherCAT NET RUN		EtherCAT NET ERR		EtherCAT LINK/ACT	
	---		---		---	
System-defined variables	Variable		Data type		Name	
	None		---		---	
Cause and correction	Assumed cause		Remedy		Prevention	
	Non-volatile memory failure		Replace the Servo Drive.		None	
Attached information	None					
Precautions/Remarks	“37” is displayed on the Servo Drive front panel and F037 is given as the AlarmCode (4001 hex).					

Event name	Object Corrupted			Event code	14AC0000 hex	
Meaning	The checksum data in non-volatile memory is corrupted.					
Source	EtherCAT Master Function Module		Source details	Slave	Detection timing	When establishing communications after turning ON power to the slave
Error attributes	Level	Minor fault	Recovery	Error reset (after cycling slave power)	Log category	System
Effects	User program	Continues.	Operation	Power drive circuit is OFF for relevant slave.		
Indicators	EtherCAT NET RUN		EtherCAT NET ERR		EtherCAT LINK/ACT	
	---		---		---	
System-defined variables	Variable		Data type		Name	
	None		---		---	
Cause and correction	Assumed cause		Remedy		Prevention	
	Non-volatile memory failure		Replace the Servo Drive.		None	
Attached information	None					
Precautions/Remarks	“37” is displayed on the Servo Drive front panel and F137 is given as the AlarmCode (4001 hex).					

Event name	Object Corrupted		Event code	14AD0000 hex		
Meaning	The checksum data in non-volatile memory is corrupted.					
Source	EtherCAT Master Function Module		Source details	Slave	Detection timing	When establishing communications after turning ON power to the slave
Error attributes	Level	Minor fault	Recovery	Error reset (after cycling slave power)	Log category	System
Effects	User program	Continues.	Operation	Power drive circuit is OFF for relevant slave.		
Indicators	EtherCAT NET RUN		EtherCAT NET ERR		EtherCAT LINK/ACT	
	---		---		---	
System-defined variables	Variable		Data type		Name	
	None		---		---	
Cause and correction	Assumed cause		Remedy		Prevention	
	Non-volatile memory failure		Replace the Servo Drive.		None	
Attached information	None					
Precautions/Remarks	"37" is displayed on the Servo Drive front panel and F237 is given as the AlarmCode (4001 hex).					

Event name	Absolute Encoder Overspeed Error		Event code	18200000 hex		
Meaning	The Servomotor rotation speed exceeded the specified value when only the battery power supply was used during a power interruption.					
Source	EtherCAT Master Function Module		Source details	Slave	Detection timing	Continuously
Error attributes	Level	Minor fault	Recovery	Error reset (after resetting slave errors)	Log category	System
Effects	User program	Continues.	Operation	Power drive circuit is OFF for relevant slave.		
Indicators	EtherCAT NET RUN		EtherCAT NET ERR		EtherCAT LINK/ACT	
	---		---		---	
System-defined variables	Variable		Data type		Name	
	None		---		---	
Cause and correction	Assumed cause		Remedy		Prevention	
	There is insufficient power supply voltage for the encoder.		Provide the required encoder power supply voltage of 5 V \pm 5%.		Provide the required encoder power supply voltage of 5 V \pm 5%.	
	The wiring of the CN2 connector is wrong.		Correct the wiring of the CN2 connector.		Connect the wiring of the CN2 connector correctly.	
	An external force is rotating the motor when the Servo is OFF.		Make sure that the motor is not rotated by an external force.		Make sure that the motor is not rotated by an external force.	
Attached information	None					
Precautions/Remarks	"42" is displayed on the Servo Drive front panel and F042 is given as the AlarmCode (4001 hex).					

Event name	Encoder Initialization Error			Event code	18210000 hex	
Meaning	An encoder initialization error was detected.					
Source	EtherCAT Master Function Module		Source details	Slave	Detection timing	When establishing communications after turning ON power to the slave
Error attributes	Level	Minor fault	Recovery	Error reset (after cycling slave power)	Log category	System
Effects	User program	Continues.	Operation	Power drive circuit is OFF for relevant slave.		
Indicators	EtherCAT NET RUN		EtherCAT NET ERR		EtherCAT LINK/ACT	
	---		---		---	
System-defined variables	Variable		Data type		Name	
	None		---		---	
Cause and correction	Assumed cause		Remedy		Prevention	
	Servomotor failed.		Replace the Servomotor.		None	
Attached information	None					
Precautions/Remarks	“43” is displayed on the Servo Drive front panel and F043 is given as the AlarmCode (4001 hex).					

Event name	Absolute Encoder One-rotation Counter Error			Event code	18220000 hex	
Meaning	The encoder detected a one-rotation counter error.					
Source	EtherCAT Master Function Module		Source details	Slave	Detection timing	Continuously
Error attributes	Level	Minor fault	Recovery	Error reset (after cycling slave power)	Log category	System
Effects	User program	Continues.	Operation	Power drive circuit is OFF for relevant slave.		
Indicators	EtherCAT NET RUN		EtherCAT NET ERR		EtherCAT LINK/ACT	
	---		---		---	
System-defined variables	Variable		Data type		Name	
	None		---		---	
Cause and correction	Assumed cause		Remedy		Prevention	
	Servomotor failed.		Replace the Servomotor.		None	
Attached information	None					
Precautions/Remarks	“44” is displayed on the Servo Drive front panel and F044 is given as the AlarmCode (4001 hex).					

Event name	Absolute Encoder Multi-rotation Counter Error			Event code	18230000 hex	
Meaning	The encoder detected a multi-rotation counter error.					
Source	EtherCAT Master Function Module		Source details	Slave	Detection timing	Continuously
Error attributes	Level	Minor fault	Recovery	Error reset (after cycling slave power)	Log category	System
Effects	User program	Continues.	Operation	Power drive circuit is OFF for relevant slave.		
Indicators	EtherCAT NET RUN		EtherCAT NET ERR		EtherCAT LINK/ACT	
	---		---		---	
System-defined variables	Variable		Data type		Name	
	None		---		---	
Cause and correction	Assumed cause		Remedy		Prevention	
	Servomotor failed.		Replace the Servomotor.		None	
Attached information	None					
Precautions/Remarks	"45" is displayed on the Servo Drive front panel and F045 is given as the AlarmCode (4001 hex).					

Event name	Motor Non-conformity			Event code	24680000 hex	
Meaning	The Servo Drive and Servomotor combination is not correct.					
Source	EtherCAT Master Function Module		Source details	Slave	Detection timing	Continuously
Error attributes	Level	Minor fault	Recovery	Error reset (after cycling slave power supply)	Log category	System
Effects	User program	Continues.	Operation	Power drive circuit is OFF for relevant slave.		
Indicators	EtherCAT NET RUN		EtherCAT NET ERR		EtherCAT LINK/ACT	
	---		---		---	
System-defined variables	Variable		Data type		Name	
	None		---		---	
Cause and correction	Assumed cause		Remedy		Prevention	
	The Servo Drive and Servomotor combination is not correct.		Replace the Servomotor with one that matches the Servo Drive.		Use a Servomotor that matches the Servo Drive.	
Attached information	None					
Precautions/Remarks	"95" is displayed on the Servo Drive front panel and F095 is given as the AlarmCode (4001 hex).					

Event name	Motor Non-conformity			Event code	24690000 hex	
Meaning	The Servo Drive and Servomotor combination is not correct.					
Source	EtherCAT Master Function Module		Source details	Slave	Detection timing	Continuously
Error attributes	Level	Minor fault	Recovery	Error reset (after cycling slave power)	Log category	System
Effects	User program	Continues.	Operation	Power drive circuit is OFF for relevant slave.		
Indicators	EtherCAT NET RUN		EtherCAT NET ERR		EtherCAT LINK/ACT	
	---		---		---	
System-defined variables	Variable		Data type		Name	
	None		---		---	
Cause and correction	Assumed cause		Remedy		Prevention	
	The Servo Drive and Servomotor combination is not correct.		Replace the Servomotor with one that matches the Servo Drive.		Use a Servomotor that matches the Servo Drive.	
Attached information	None					
Precautions/Remarks	"95" is displayed on the Servo Drive front panel and F195 is given as the AlarmCode (4001 hex).					

Event name	Motor Non-conformity			Event code	246A0000 hex	
Meaning	The Servo Drive and Servomotor combination is not correct.					
Source	EtherCAT Master Function Module		Source details	Slave	Detection timing	Continuously
Error attributes	Level	Minor fault	Recovery	Error reset (after cycling slave power)	Log category	System
Effects	User program	Continues.	Operation	Power drive circuit is OFF for relevant slave.		
Indicators	EtherCAT NET RUN		EtherCAT NET ERR		EtherCAT LINK/ACT	
	---		---		---	
System-defined variables	Variable		Data type		Name	
	None		---		---	
Cause and correction	Assumed cause		Remedy		Prevention	
	The Servo Drive and Servomotor combination is not correct.		Replace the Servomotor with one that matches the Servo Drive.		Use a Servomotor that matches the Servo Drive.	
Attached information	None					
Precautions/Remarks	"95" is displayed on the Servo Drive front panel and F295 is given as the AlarmCode (4001 hex).					

Event name	Motor Non-conformity			Event code	246B0000 hex	
Meaning	The Servo Drive and Servomotor combination is not correct.					
Source	EtherCAT Master Function Module		Source details	Slave	Detection timing	Continuously
Error attributes	Level	Minor fault	Recovery	Error reset (after cycling slave power)	Log category	System
Effects	User program	Continues.	Operation	Power drive circuit is OFF for relevant slave.		
Indicators	EtherCAT NET RUN		EtherCAT NET ERR		EtherCAT LINK/ACT	
	---		---		---	
System-defined variables	Variable		Data type		Name	
	None		---		---	
Cause and correction	Assumed cause		Remedy		Prevention	
	The Servo Drive and Servomotor combination is not correct.		Replace the Servomotor with one that matches the Servo Drive.		Use a Servomotor that matches the Servo Drive.	
Attached information	None					
Precautions/Remarks	"95" is displayed on the Servo Drive front panel and F395 is given as the AlarmCode (4001 hex).					

Event name	Motor Non-conformity			Event code	246C0000 hex	
Meaning	The Servo Drive and Servomotor combination is not correct.					
Source	EtherCAT Master Function Module		Source details	Slave	Detection timing	Continuously
Error attributes	Level	Minor fault	Recovery	Error reset (after cycling slave power)	Log category	System
Effects	User program	Continues.	Operation	Power drive circuit is OFF for relevant slave.		
Indicators	EtherCAT NET RUN		EtherCAT NET ERR		EtherCAT LINK/ACT	
	---		---		---	
System-defined variables	Variable		Data type		Name	
	None		---		---	
Cause and correction	Assumed cause		Remedy		Prevention	
	The Servo Drive and Servomotor combination is not correct.		Replace the Servomotor with one that matches the Servo Drive.		Use a Servomotor that matches the Servo Drive.	
Attached information	None					
Precautions/Remarks	"95" is displayed on the Servo Drive front panel and F495 is given as the AlarmCode (4001 hex).					

Event name	Servo Drive Overheat		Event code	34E10000 hex		
Meaning	The temperature of the Servo Drive radiator or power elements exceeded the specified value.					
Source	EtherCAT Master Function Module		Source details	Slave	Detection timing	Continuously
Error attributes	Level	Minor fault	Recovery	Error reset (after cycling slave power)	Log category	System
Effects	User program	Continues.	Operation	Power drive circuit is OFF for relevant slave.		
Indicators	EtherCAT NET RUN		EtherCAT NET ERR		EtherCAT LINK/ACT	
	---		---		---	
System-defined variables	Variable		Data type		Name	
	None		---		---	
Cause and correction	Assumed cause		Remedy		Prevention	
	The ambient temperature of the Servo Drive exceeded the specified value.		Improve the ambient temperature and the cooling conditions of the Servo Drive.		Check the ambient temperature of the Servo Drive and set up the necessary cooling conditions.	
	Overload		Increase the capacities of the Servo Drive and the Servomotor. Or, increase the setting of the acceleration/deceleration time and lighten the load.		Increase the setting of the acceleration/deceleration time and lighten the load as much as possible.	
Attached information	None					
Precautions/Remarks	"15" is displayed on the Servo Drive front panel and F015 is given as the AlarmCode (4001 hex)					

Event name	Overload		Event code	34E20000 hex		
Meaning	When the feedback value for torque command exceeds the overload level specified in the Overload Detection Level Setting (3512 hex), overload protection is performed according to the overload characteristics.					
Source	EtherCAT Master Function Module		Source details	Slave	Detection timing	While power is supplied to motor
Error attributes	Level	Minor fault	Recovery	Error reset (after resetting slave errors)	Log category	System
Effects	User program	Continues.	Operation	Power drive circuit is OFF for relevant slave.		
Indicators	EtherCAT NET RUN		EtherCAT NET ERR		EtherCAT LINK/ACT	
	---		---		---	
System-defined variables	Variable		Data type		Name	
	None		---		---	
Cause and correction	Assumed cause		Remedy		Prevention	
	Operation was continued for a long time while overloaded.		<p>Take the following actions according to the situation.</p> <ul style="list-style-type: none"> • Increase the capacities of the Servo Drive and the Servomotor. • Increase the setting of the acceleration/deceleration time and lighten the load. • Adjust the gain or inertial ratio and remove machine distortion. • Measure the voltage at the brake terminal. If the brake is ON, release it. • Correct the system if torque (current) waveforms oscillate or excessively oscillate vertically during analog output or communications. 		Check the items given for corrections in advance and implement countermeasures as required.	
There is incorrect wiring of the motor line or a broken cable.		<p>Connect the Servomotor cable as shown in the wiring diagram. If the cable is broken, replace it.</p> <p>Connect the motor line and encoder line that are used together to the same motor.</p>		Connect the Servomotor cable as shown in the wiring diagram. Connect the motor line and encoder line that are used together to the same motor.		
Attached information	None					
Precautions/Remarks	“16” is displayed on the Servo Drive front panel and F016 is given as the AlarmCode (4001 hex)					

Event name	Regeneration Overload		Event code	34E30000 hex		
Meaning	The regenerative energy exceeds the processing capacity of the Regeneration Resistor.					
Source	EtherCAT Master Function Module		Source details	Slave	Detection timing	While power is supplied to motor
Error attributes	Level	Minor fault	Recovery	Error reset (after cycling slave power)	Log category	System
Effects	User program	Continues.	Operation	Power drive circuit is OFF for relevant slave.		
Indicators	EtherCAT NET RUN		EtherCAT NET ERR		EtherCAT LINK/ACT	
	---		---		---	
System-defined variables	Variable		Data type		Name	
	None		---		---	
Cause and correction	Assumed cause		Remedy		Prevention	
	The load inertia is too large. Or, the Servomotor rotation speed is too high to absorb the regenerative energy within the specified deceleration time.		<p>Check the operation pattern (velocity monitor). Check the Regeneration Register load rate and the excessive regeneration warning, and perform the following accordingly.</p> <ul style="list-style-type: none"> • Increase the capacity of the Servomotor and Servo Drive. • Increase the deceleration time. • Reduce the Servomotor rotation speed. • Use an External Regeneration Resistor. • Set the Regeneration Resistor Selection (3016 hex) to 2. 		Check the items given for corrections in advance and implement countermeasures as required.	
	This Regeneration Resistor cannot be used for continuous regenerative braking. (The operating limit of the external resistor is limited to a 10% duty.)		Set the Regeneration Resistor Selection (3016 hex) to 2.		Set the Regeneration Resistor Selection (3016 hex) to 2.	
Attached information	None					
Precautions/Remarks	"18" is displayed on the Servo Drive front panel and F018 is given as the AlarmCode (4001 hex)					

Event name	Error Counter Overflow		Event code	34E40000 hex		
Meaning	Position error pulses exceeded the setting of the Following error window (6065 hex).					
Source	EtherCAT Master Function Module		Source details	Slave	Detection timing	While power is supplied to motor
Error attributes	Level	Minor fault	Recovery	Error reset (after resetting slave errors)	Log category	System
Effects	User program	Continues.	Operation	Power drive circuit is OFF for relevant slave.		
Indicators	EtherCAT NET RUN		EtherCAT NET ERR		EtherCAT LINK/ACT	
	---		---		---	
System-defined variables	Variable		Data type		Name	
	None		---		---	
Cause and correction	Assumed cause		Remedy		Prevention	
	Motor operation does not follow the command.		<p>Make sure that the motor rotates according to the position command input, and that the output torque is not saturated on the torque monitor. If there is a problem, perform the following.</p> <ul style="list-style-type: none"> Adjust the gain. Set the torque limit objects (60E0 hex, 60E1 hex, 3013 hex, 3522 hex, 3525 hex, and 3526 hex) to the maximum settings. Increase the acceleration/ deceleration time, lighten the load, and reduce the velocity. 		Adjust the gain and torque limits. Increase the acceleration/ deceleration time, lighten the load, and reduce the velocity as much as possible.	
	The value of the Following error window (6065 hex) is small.		Increase the setting of the Following error window (6065 hex) to an acceptable range.		Increase the setting of the Following error window (6065 hex) to an acceptable range.	
	The encoder wiring is incorrect.		Wire the encoder correctly as shown in the wiring diagram.		Wire the encoder correctly as shown in the wiring diagram.	
Attached information	None					
Precautions/Remarks	"24" is displayed on the Servo Drive front panel and F024 is given as the AlarmCode (4001 hex)					

Event name	Excessive Velocity Error			Event code	34E50000 hex	
Meaning	The difference between the internal position command velocity and the actual velocity (i.e., the velocity error) exceeded the Excessive Velocity Error Setting (3602 hex).					
Source	EtherCAT Master Function Module		Source details	Slave	Detection timing	While power is supplied to motor
Error attributes	Level	Minor fault	Recovery	Error reset (after resetting slave errors)	Log category	System
Effects	User program	Continues.	Operation	Power drive circuit is OFF for relevant slave.		
Indicators	EtherCAT NET RUN		EtherCAT NET ERR		EtherCAT LINK/ACT	
	---		---		---	
System-defined variables	Variable		Data type		Name	
	None		---		---	
Cause and correction	Assumed cause		Remedy		Prevention	
	Motor operation does not follow the command.		Adjust the gain to improve the following ability. Increase the acceleration/deceleration time for the internal position command velocity.		Adjust the gain to improve the following ability. Increase the acceleration/deceleration time for the internal position command velocity as much as possible.	
	The setting of the Excessive Velocity Error Setting (3602 hex) is too small.		Increase the setting of the Excessive Velocity Error Setting (3602 hex) to an acceptable range. If there is no need to monitor the velocity error, disable detection of Excessive Velocity Error. (3602 hex = 0)		Increase the setting of the Excessive Velocity Error Setting (3602 hex) to an acceptable range. If there is no need to monitor the velocity error, disable detection of Excessive Velocity Error. (3602 hex = 0)	
Attached information	None					
Precautions/Remarks	“24” is displayed on the Servo Drive front panel and F124 is given as the AlarmCode (4001 hex)					

Event name	Overspeed			Event code	34E60000 hex	
Meaning	The Servomotor rotation speed exceeded the value set on the Overspeed Detection Level Setting (3513 hex).					
Source	EtherCAT Master Function Module		Source details	Slave	Detection timing	While power is supplied to motor
Error attributes	Level	Minor fault	Recovery	Error reset (after removing slave error)	Log category	System
Effects	User program	Continues.	Operation	Power drive circuit is OFF for relevant slave.		
Indicators	EtherCAT NET RUN		EtherCAT NET ERR		EtherCAT LINK/ACT	
	---		---		---	
System-defined variables	Variable		Data type		Name	
	None		---		---	
Cause and correction	Assumed cause		Remedy		Prevention	
	The velocity command value is too large.		Reduce the velocity command value. Adjust the input frequency, dividing ratio, and multiplication ratio of the command pulse.		Set the velocity command value so that the number of motor rotations does not exceed the overspeed detection level. Check the input frequency, dividing ratio, and multiplication ratio of the command pulse.	
	There is overshooting.		Decrease the gain.		Do not make the gain too large.	
	The wiring is incorrect.		Wire the encoder correctly as shown in the wiring diagram.		Wire the encoder correctly as shown in the wiring diagram.	
Attached information	None					
Precautions/Remarks	“26” is displayed on the Servo Drive front panel and F026 is given as the AlarmCode (4001 hex)					

Event name	Excessive Hybrid Following Error		Event code	383F0000 hex		
Meaning	During fully-closed control, the difference between the load position from the external encoder and the Servomotor position from the encoder was larger than the number of pulses set as the Hybrid Following Error Counter Overflow Level (3328 hex).					
Source	EtherCAT Master Function Module		Source details	Slave	Detection timing	While power is supplied to motor
Error attributes	Level	Minor fault	Recovery	Error reset (after cycling slave power)	Log category	System
Effects	User program	Continues.	Operation	Power drive circuit is OFF for relevant slave.		
Indicators	EtherCAT NET RUN		EtherCAT NET ERR		EtherCAT LINK/ACT	
	---		---		---	
System-defined variables	Variable	Data type		Name		
	None	---		---		
Cause and correction	Assumed cause		Remedy		Prevention	
	Connections are not correct.		Correct any mistakes in the connections between the Servomotor and load or between the external encoder and Servo Drive.		Make sure that the connections between the Servomotor and load or between the external encoder and Servo Drive are correct.	
	The settings are not correct.		If the change in the Servomotor position (encoder feedback value) and the change in the load position (external encoder feedback value) do not have matching signs when the load is moved, correct the settings of the External Feedback Pulse Dividing Numerator and Denominator (3324 hex and 3325 hex), and the External Feedback Pulse Direction Switching (3326 hex).		Set the External Feedback Pulse Dividing Numerator and Denominator as well as the External Feedback Pulse Direction Switching so that the change in the Servomotor position and change in the load position result in the same sign when the load is moved.	
Attached information	None					
Precautions/Remarks	"25" is displayed on the Servo Drive front panel and F025 is given as the AlarmCode (4001 hex)					

Event name	Overspeed 2			Event code	38400000 hex	
Meaning	The Servomotor rotation speed exceeded the value set on Overspeed Detection Level Setting at Immediate Stop (3615 hex).					
Source	EtherCAT Master Function Module		Source details	Slave	Detection timing	While power is supplied to motor
Error attributes	Level	Minor fault	Recovery	Error reset (after resetting slave errors)	Log category	System
Effects	User program	Continues.	Operation	Power drive circuit is OFF for relevant slave.		
Indicators	EtherCAT NET RUN		EtherCAT NET ERR		EtherCAT LINK/ACT	
	---		---		---	
System-defined variables	Variable		Data type		Name	
	None		---		---	
Cause and correction	Assumed cause		Remedy		Prevention	
	The velocity command value is too large.		Reduce the velocity. Adjust the input frequency, dividing ratio, and multiplication ratio of the command pulse.		Set the velocity command value in a range that does not exceed the overspeed detection level when the number of motor rotations is stopped immediately. Check the input frequency, dividing ratio, and multiplication ratio of the command pulse.	
	There is overshooting.		Adjust the gain.		Do not make the gain too large.	
	The wiring is incorrect.		Wire the encoder correctly as shown in the wiring diagram.		Wire the encoder correctly as shown in the wiring diagram.	
Attached information	None					
Precautions/Remarks	"26" is displayed on the Servo Drive front panel and F126 is given as the AlarmCode (4001 hex)					

Event name	Command Error			Event code	38410000 hex	
Meaning	The position command variation after the electronic gear exceeded the specified value.					
Source	EtherCAT Master Function Module		Source details	Slave	Detection timing	Continuously
Error attributes	Level	Minor fault	Recovery	Error reset (after cycling slave power)	Log category	System
Effects	User program	Continues.	Operation	Power drive circuit is OFF for relevant slave.		
Indicators	EtherCAT NET RUN		EtherCAT NET ERR		EtherCAT LINK/ACT	
	---		---		---	
System-defined variables	Variable		Data type		Name	
	None		---		---	
Cause and correction	Assumed cause		Remedy		Prevention	
	The change in position command is too large.		Reduce the electronic gear ratio.		Adjust the electronic gear ratio so that the changes in the position command are not too large.	
	The backlash compensation amount is too large.		Reduce the backlash compensation amount.		Adjust the backlash compensation amount so that the changes in the position command are not too large.	
Attached information	None					
Precautions/Remarks	"27" is displayed on the Servo Drive front panel and F427 is given as the AlarmCode (4001 hex)					

Event name	Command Generation Error		Event code	38420000 hex		
Meaning	During position command processing, an error such as a calculation range error occurred.					
Source	EtherCAT Master Function Module		Source details	Slave	Detection timing	Continuously
Error attributes	Level	Minor fault	Recovery	Error reset (after cycling slave power)	Log category	System
Effects	User program	Continues.	Operation	Power drive circuit is OFF for relevant slave.		
Indicators	EtherCAT NET RUN		EtherCAT NET ERR		EtherCAT LINK/ACT	
	---		---		---	
System-defined variables	Variable		Data type		Name	
	None		---		---	
Cause and correction	Assumed cause		Remedy		Prevention	
	During position command processing, an error such as a calculation range error occurred.		Check whether the electronic gear ratio and acceleration/deceleration rate are within the limits and make any necessary corrections.		Set the electronic gear ratio, acceleration rate, and deceleration rate to meet the restrictions.	
Attached information	None					
Precautions/Remarks	"27" is displayed on the Servo Drive front panel and F527 is given as the AlarmCode (4001 hex)					

Event name	Error Counter Overflow 1		Event code	38430000 hex		
Meaning	The absolute encoder (absolute scale) position in pulses divided by the electronic gear ratio exceeded $\pm 2^{31}$ (2,147,483,648).					
Source	EtherCAT Master Function Module		Source details	Slave	Detection timing	While power is supplied to motor
Error attributes	Level	Minor fault	Recovery	Error reset (after cycling slave power)	Log category	System
Effects	User program	Continues.	Operation	Power drive circuit is OFF for relevant slave.		
Indicators	EtherCAT NET RUN		EtherCAT NET ERR		EtherCAT LINK/ACT	
	---		---		---	
System-defined variables	Variable		Data type		Name	
	None		---		---	
Cause and correction	Assumed cause		Remedy		Prevention	
	The absolute encoder (absolute scale) position in pulses divided by the electronic gear ratio exceeded $\pm 2^{31}$ (2,147,483,648).		Check the operation range of the absolute external encoder position and correct the electronic gear ratio.		Check the operation range of the absolute external encoder position and adjust the electronic gear ratio.	
Attached information	None					
Precautions/Remarks	"29" is displayed on the Servo Drive front panel and F129 is given as the AlarmCode (4001 hex)					

Event name	Error Counter Overflow 2		Event code	38440000 hex		
Meaning	The position following error in pulses exceeded $\pm 2^{29}$ (536,870,912). Or, the position following error in command units exceeded $\pm 2^{30}$ (1,073,741,824).					
Source	EtherCAT Master Function Module		Source details	Slave	Detection timing	While power is supplied to motor
Error attributes	Level	Minor fault	Recovery	Error reset (after cycling slave power)	Log category	System
Effects	User program	Continues.	Operation	Power drive circuit is OFF for relevant slave.		
Indicators	EtherCAT NET RUN		EtherCAT NET ERR		EtherCAT LINK/ACT	
	---		---		---	
System-defined variables	Variable		Data type		Name	
	None		---		---	
Cause and correction	Assumed cause		Remedy		Prevention	
	There is insufficient torque.		Lighten the load if the output torque is saturated on the torque monitor. Set the torque limit objects (60E0 hex, 60E1 hex, 3013 hex, 3522 hex, 3525 hex, and 3526 hex) to the maximum settings.		Adjust the gain and torque limits.	
	There is insufficient gain.		Increase the gain.			
	The encoder wiring is incorrect.		Wire the encoder correctly as shown in the wiring diagram.		Wire the encoder correctly as shown in the wiring diagram.	
Attached information	None					
Precautions/Remarks	"29" is displayed on the Servo Drive front panel and F229 is given as the AlarmCode (4001 hex).					

Event name	Interface Input Duplicate Allocation Error 1		Event code	38450000 hex		
Meaning	There is a duplicate setting in the input signal (IN1, IN2, IN3, and IN4) function allocations.					
Source	EtherCAT Master Function Module		Source details	Slave	Detection timing	When establishing communications after turning ON power to the slave or when transferring EtherCAT Configuration Setup
Error attributes	Level	Minor fault	Recovery	Error reset (after cycling slave power)	Log category	System
Effects	User program	Continues.	Operation	Power drive circuit is OFF for relevant slave.		
Indicators	EtherCAT NET RUN		EtherCAT NET ERR		EtherCAT LINK/ACT	
	---		---		---	
System-defined variables	Variable		Data type		Name	
	None		---		---	
Cause and correction	Assumed cause		Remedy		Prevention	
	There is a duplicate setting in the input signal (IN1, IN2, IN3, and IN4) function allocations.		Allocate the functions to the connector pins so that each function is allocated only once.		Allocate the functions to the connector pins so that each function is allocated only once.	
Attached information	None					
Precautions/Remarks	"33" is displayed on the Servo Drive front panel and F033 is given as the AlarmCode (4001 hex).					

Event name	Interface Input Duplicate Allocation Error 2		Event code	38460000 hex		
Meaning	There is a duplicate setting in the input signal (IN5, IN6, IN7, and IN8) function allocations.					
Source	EtherCAT Master Function Module	Source details	Slave	Detection timing	When establishing communications after turning ON power to the slave or when transferring EtherCAT Configuration Setup	
Error attributes	Level	Minor fault	Recovery	Error reset (after cycling slave power)	Log category	System
Effects	User program	Continues.	Operation	Power drive circuit is OFF for relevant slave.		
Indicators	EtherCAT NET RUN		EtherCAT NET ERR		EtherCAT LINK/ACT	
	---		---		---	
System-defined variables	Variable	Data type		Name		
	None	---		---		
Cause and correction	Assumed cause		Remedy		Prevention	
	There is a duplicate setting in the input signal (IN5, IN6, IN7, and IN8) function allocations.		Allocate the functions to the connector pins so that each function is allocated only once.		Allocate the functions to the connector pins so that each function is allocated only once.	
Attached information	None					
Precautions/Remarks	"33" is displayed on the Servo Drive front panel and F133 is given as the AlarmCode (4001 hex).					

Event name	Interface Input Function Number Error 1		Event code	38470000 hex		
Meaning	There is an undefined number specification in the input signal (IN1, IN2, IN3, and IN4) function allocations. Or, a logic setting error was detected.					
Source	EtherCAT Master Function Module		Source details	Slave	Detection timing	When establishing communications after turning ON power to the slave or when transferring EtherCAT Configuration Setup
Error attributes	Level	Minor fault	Recovery	Error reset (after cycling slave power)	Log category	System
Effects	User program	Continues.	Operation	Power drive circuit is OFF for relevant slave.		
Indicators	EtherCAT NET RUN		EtherCAT NET ERR		EtherCAT LINK/ACT	
	---		---		---	
System-defined variables	Variable	Data type		Name		
	None	---		---		
Cause and correction	Assumed cause		Remedy		Prevention	
	There is an undefined number specification in the input signal (IN1, IN2, IN3, and IN4) function allocations.		Allocate the functions to the connector pins using only the numbers that are defined.		Allocate the functions to the connector pins using only the numbers that are defined.	
	Different logic is set for the same function in the function assignments of the input signals (IN1, IN2, IN3, and IN4).		Correct the settings so that the same logic is used for the same function.		Use the same logic for the same function.	
Attached information	None					
Precautions/Remarks	"33" is displayed on the Servo Drive front panel and F233 is given as the AlarmCode (4001 hex).					

Event name	Interface Input Function Number Error 2		Event code	38480000 hex		
Meaning	There is an undefined number specification in the input signal (IN5, IN6, IN7, and IN8) function allocations. Or, a logic setting error was detected.					
Source	EtherCAT Master Function Module		Source details	Slave	Detection timing	When establishing communications after turning ON power to the slave or when transferring EtherCAT Configuration Setup
Error attributes	Level	Minor fault	Recovery	Error reset (after cycling slave power)	Log category	System
Effects	User program	Continues.	Operation	Power drive circuit is OFF for relevant slave.		
Indicators	EtherCAT NET RUN		EtherCAT NET ERR		EtherCAT LINK/ACT	
	---		---		---	
System-defined variables	Variable	Data type		Name		
	None	---		---		
Cause and correction	Assumed cause		Remedy		Prevention	
	There is an undefined number specification in the input signal (IN5, IN6, IN7, and IN8) function allocations.		Allocate the functions to the connector pins using only the numbers that are defined.		Allocate the functions to the connector pins using only the numbers that are defined.	
	Different logic is set for the same function in the function assignments of the input signals (IN5, IN6, IN7, and IN8).		Correct the settings so that the same logic is used for the same function.		Use the same logic for the same function.	
Attached information	None					
Precautions/Remarks	"33" is displayed on the Servo Drive front panel and F333 is given as the AlarmCode (4001 hex).					

Event name	Interface Output Function Number Error 1			Event code	38490000 hex	
Meaning	There is an undefined number specification in the output signal (OUTM1) function allocation.					
Source	EtherCAT Master Function Module		Source details	Slave	Detection timing	When establishing communications after turning ON power to the slave or when transferring EtherCAT Configuration Setup
Error attributes	Level	Minor fault	Recovery	Error reset (after cycling slave power)	Log category	System
Effects	User program	Continues.	Operation	Power drive circuit is OFF for relevant slave.		
Indicators	EtherCAT NET RUN		EtherCAT NET ERR		EtherCAT LINK/ACT	
	---		---		---	
System-defined variables	Variable		Data type		Name	
	None		---		---	
Cause and correction	Assumed cause		Remedy		Prevention	
	There is an undefined number specification in the output signal (OUTM1) function allocation.		Allocate the functions to the connector pins using only the numbers that are defined.		Allocate the functions to the connector pins using only the numbers that are defined.	
Attached information	None					
Precautions/Remarks	"33" is displayed on the Servo Drive front panel and F433 is given as the AlarmCode (4001 hex).					

Event name	Interface Output Function Number Error 2			Event code	384A0000 hex	
Meaning	There is an undefined number specification in the output signal (OUTM2) function allocation.					
Source	EtherCAT Master Function Module		Source details	Slave	Detection timing	When establishing communications after turning ON power to the slave or when transferring EtherCAT Configuration Setup
Error attributes	Level	Minor fault	Recovery	Error reset (after cycling slave power)	Log category	System
Effects	User program	Continues.	Operation	Power drive circuit is OFF for relevant slave.		
Indicators	EtherCAT NET RUN		EtherCAT NET ERR		EtherCAT LINK/ACT	
	---		---		---	
System-defined variables	Variable		Data type		Name	
	None		---		---	
Cause and correction	Assumed cause		Remedy		Prevention	
	There is an undefined number specification in the output signal (OUTM2) function allocation.		Allocate the functions to the connector pins using only the numbers that are defined.		Allocate the functions to the connector pins using only the numbers that are defined.	
Attached information	None					
Precautions/Remarks	"33" is displayed on the Servo Drive front panel and F533 is given as the AlarmCode (4001 hex).					

Event name	External Latch Input Allocation Error			Event code	384B0000 hex	
Meaning	There is an error in the latch input function allocation.					
Source	EtherCAT Master Function Module		Source details	Slave	Detection timing	When establishing communications after turning ON power to the slave or when transferring EtherCAT Configuration Setup
Error attributes	Level	Minor fault	Recovery	Error reset (after cycling slave power)	Log category	System
Effects	User program	Continues.	Operation	Power drive circuit is OFF for relevant slave.		
Indicators	EtherCAT NET RUN		EtherCAT NET ERR		EtherCAT LINK/ACT	
	---		---		---	
System-defined variables	Variable	Data type		Name		
	None	---		---		
Cause and correction	Assumed cause		Remedy		Prevention	
	The latch input was allocated to an input signal other than IN5, IN6, or IN7.		Allocate the latch input to input signals IN5, IN6, or IN7.		Allocate the latch input to input signals IN5, IN6, or IN7.	
	A latch input is assigned to an NC signal.		Assign a latch input to an NO signal.		Assign a latch input to an NO signal.	
	The same latch input is not assigned to the same pin in all Control Modes.		Assign the same latch input in all Control Modes.		Assign the same latch input to the same pin in all Control Modes.	
Attached information	None					
Precautions/Remarks	"33" is displayed on the Servo Drive front panel and F833 is given as the AlarmCode (4001 hex).					

Event name	Overrun Limit Error			Event code	384C0000 hex	
Meaning	The Servomotor exceeded the allowable operating range set in the Overrun Limit Setting (3514 hex) with respect to the position command input range.					
Source	EtherCAT Master Function Module		Source details	Slave	Detection timing	While power is supplied to motor
Error attributes	Level	Minor fault	Recovery	Error reset (after resetting slave errors)	Log category	System
Effects	User program	Continues.	Operation	Power drive circuit is OFF for relevant slave.		
Indicators	EtherCAT NET RUN		EtherCAT NET ERR		EtherCAT LINK/ACT	
	---		---		---	
System-defined variables	Variable	Data type		Name		
	None	---		---		
Cause and correction	Assumed cause		Remedy		Prevention	
	The gain or inertial ratio is not suitable.		Adjust the gain (the balance between position loop gain and velocity loop gain) and the inertia ratio.		Adjust the gain or inertial ratio.	
	The set value of the Overrun Limit Setting (3514 hex) is too small.		Increase the set value of the Overrun Limit Setting (3514 hex). Disable the protective function if it is unnecessary.		Increase the set value of the Overrun Limit Setting (3514 hex). Disable the protective function if it is unnecessary.	
Attached information	None					
Precautions/Remarks	"34" is displayed on the Servo Drive front panel and F034 is given as the AlarmCode (4001 hex).					

Event name	Absolute Encoder System Down Error		Event code	384D0000 hex		
Meaning	The voltage of the built-in capacitor dropped below the specified value because the power supply to the encoder or the battery power supply was down.					
Source	EtherCAT Master Function Module		Source details	Slave	Detection timing	Continuously
Error attributes	Level	Minor fault	Recovery	Error reset (after resetting slave errors)	Log category	System
Effects	User program	Continues.	Operation	Power drive circuit is OFF for relevant slave.		
Indicators	EtherCAT NET RUN		EtherCAT NET ERR		EtherCAT LINK/ACT	
	---		---		---	
System-defined variables	Variable		Data type		Name	
	None		---		---	
Cause and correction	Assumed cause		Remedy		Prevention	
	The voltage of the built-in capacitor dropped below the specified value because the power supply to the encoder or the battery power supply was down.		Reset the power supply to the encoder and to the battery, and then clear the absolute encoder.		None	
Attached information	None					
Precautions/Remarks	"40" is displayed on the Servo Drive front panel and F040 is given as the AlarmCode (4001 hex).					

Event name	Absolute Encoder Counter Overflow Error			Event code	384E0000 hex	
Meaning	The multi-rotation counter of the encoder exceeded the specified value.					
Source	EtherCAT Master Function Module		Source details	Slave	Detection timing	Continuously
Error attributes	Level	Minor fault	Recovery	Error reset (after cycling slave power)	Log category	System
Effects	User program	Continues.	Operation	Power drive circuit is OFF for relevant slave.		
Indicators	EtherCAT NET RUN		EtherCAT NET ERR		EtherCAT LINK/ACT	
	---		---		---	
System-defined variables	Variable		Data type		Name	
	None		---		---	
Cause and correction	Assumed cause		Remedy		Prevention	
	The set value for switching operation with the absolute encoder is too large.		Correct the Operation Switch when Using Absolute Encoder (3015 hex) to a small value.		Set the Operation Switch when Using Absolute Encoder (3015 hex) to a small value.	
	The traveling distance from home of the machine exceeded 32,767 revolutions.		Correct the traveling distance from the home of the machine so that there is no more than 32,767 revolutions.		Correct the traveling distance from the home of the machine is no more than 32,767 revolutions.	
Attached information	None					
Precautions/Remarks	"41" is displayed on the Servo Drive front panel and F041 is given as the AlarmCode (4001 hex).					

Event name	Object Setting Error 1			Event code	384F0000 hex	
Meaning	The electronic gear ratio exceeded the allowable range.					
Source	EtherCAT Master Function Module		Source details	Slave	Detection timing	Continuously
Error attributes	Level	Minor fault	Recovery	Error reset (after cycling slave power)	Log category	System
Effects	User program	Continues.	Operation	Power drive circuit is OFF for relevant slave.		
Indicators	EtherCAT NET RUN		EtherCAT NET ERR		EtherCAT LINK/ACT	
	---		---		---	
System-defined variables	Variable		Data type		Name	
	None		---		---	
Cause and correction	Assumed cause		Remedy		Prevention	
	The electronic gear ratio exceeded the allowable range.		Correct the electronic gear ratio to between 1/1,000 and 1,000.		Set the electronic gear ratio to between 1/1,000 and 1,000.	
Attached information	None					
Precautions/Remarks	"93" is displayed on the Servo Drive front panel and F093 is given as the AlarmCode (4001 hex).					

Event name	Object Setting Error 2			Event code	38500000 hex	
Meaning	External encoder ratio exceeded the allowable range.					
Source	EtherCAT Master Function Module		Source details	Slave	Detection timing	Continuously
Error attributes	Level	Minor fault	Recovery	Error reset (after cycling slave power)	Log category	System
Effects	User program	Continues.	Operation	Power drive circuit is OFF for relevant slave.		
Indicators	EtherCAT NET RUN		EtherCAT NET ERR		EtherCAT LINK/ACT	
	---		---		---	
System-defined variables	Variable		Data type		Name	
	None		---		---	
Cause and correction	Assumed cause		Remedy		Prevention	
	External encoder ratio exceeded the allowable range.		Correct the external encoder ratio to between 1/40 and 160.		Set the external encoder ratio to between 1/40 and 160.	
Attached information	None					
Precautions/Remarks	"93" is displayed on the Servo Drive front panel and F293 is given as the AlarmCode (4001 hex).					

Event name	External Encoder Connection Error			Event code	38510000 hex	
Meaning	The set value of the External Feedback Pulse Type Selection (3323 hex) differs from the external encoder type that is connected for serial communications.					
Source	EtherCAT Master Function Module		Source details	Slave	Detection timing	Continuously
Error attributes	Level	Minor fault	Recovery	Error reset (after cycling slave power)	Log category	System
Effects	User program	Continues.	Operation	Power drive circuit is OFF for relevant slave.		
Indicators	EtherCAT NET RUN		EtherCAT NET ERR		EtherCAT LINK/ACT	
	---		---		---	
System-defined variables	Variable		Data type		Name	
	None		---		---	
Cause and correction	Assumed cause		Remedy		Prevention	
	The set value of the External Feedback Pulse Type Selection (3323 hex) differs from the external encoder type that is connected for serial communications.		Set the External Feedback Pulse Type Selection (3323 hex) according to the connected external encoder type.		Set the External Feedback Pulse Type Selection (3323 hex) according to the connected external encoder type.	
Attached information	None					
Precautions/Remarks	"93" is displayed on the Servo Drive front panel and F393 is given as the AlarmCode (4001 hex).					

Event name	Function Setting Error		Event code	38520000 hex		
Meaning	The function that was set does not support the communications period.					
Source	EtherCAT Master Function Module		Source details	Slave	Detection timing	Continuously
Error attributes	Level	Minor fault	Recovery	Error reset (after resetting slave errors)	Log category	System
Effects	User program	Continues.	Operation	Power drive circuit is OFF for relevant slave.		
Indicators	EtherCAT NET RUN		EtherCAT NET ERR		EtherCAT LINK/ACT	
	---		---		---	
System-defined variables	Variable		Data type		Name	
	None		---		---	
Cause and correction	Assumed cause		Remedy		Prevention	
	The electronic gear object ratio was not 1:1 when the communications period was set to 250 or 500 μ s.		Check the following settings for any of the causes and correct any problems. <ul style="list-style-type: none"> • Communications period setting • Electronic gear object • Objects that set the Control Mode • Control Mode • Number of mapped bytes • Number of mapped objects • Mapped objects 		Check the following settings for any of the causes to make sure that problems do not occur. <ul style="list-style-type: none"> • Communications period setting • Electronic gear object • Objects that set the Control Mode • Control Mode • Number of mapped bytes • Number of mapped objects • Mapped objects 	
	Fully-closed Control Mode was selected for a communications period setting of 250 μ s.					
	Modes of operation (6060 hex) was set to pp or hm when the communications period was set to 250 or 500 μ s.					
	More than 20 bytes were mapped for RxPDO when the communications period was set to 250 μ s.					
	More than 12 bytes were mapped for RxPDO in Fully-closed Control Mode.					
	Modes of operation (6060 hex) was set to pp or hm in Fully-closed Control Mode when the communications period was set to 1 ms and the electronic gear parameter ratio was not set to 1:1.					
	No bytes (i.e., no objects) were mapped for RxPDO.					
	More than 10 objects were mapped for RxPDO.					
	More than 11 objects were mapped for TxPDO.					
CSP Switching Reference Position (4020 hex) was mapped for TxPDO when the communications period was set to 250 or 500 μ s or when the electronic gear object ratio was not set to 1:1.						
Attached information	None					
Precautions/Remarks	“93” is displayed on the Servo Drive front panel and F493 is given as the AlarmCode (4001 hex).					

Event name	Drive Prohibition Input Error 1			Event code	64E00000 hex	
Meaning	When the Drive Prohibition Input Selection (3504 hex) was set to 0, both the Forward Drive Prohibition Input (POT) and the Reverse Drive Prohibition Input (NOT) turned ON. Or, when the Drive Prohibition Input Selection (3504 hex) was set to 2, either the Forward Drive Prohibition Input (POT) or the Reverse Drive Prohibition Input (NOT) turned ON.					
Source	EtherCAT Master Function Module		Source details	Slave	Detection timing	Continuously
Error attributes	Level	Minor fault	Recovery	Error reset (after resetting slave errors)	Log category	System
Effects	User program	Continues.	Operation	Power drive circuit is OFF for relevant slave.		
Indicators	EtherCAT NET RUN		EtherCAT NET ERR		EtherCAT LINK/ACT	
	---		---		---	
System-defined variables	Variable		Data type		Name	
	None		---		---	
Cause and correction	Assumed cause		Remedy		Prevention	
	A problem occurred with the switches, wires, and power supplies that are connected to the Forward Drive Prohibition input or the Reverse Drive Prohibition input.		Remove the problem with the switches, wires, and power supplies that are connected to the Forward Drive Prohibition input or the Reverse Drive Prohibition input. In particular, check to see if the control signal power supply (12 to 24 VDC) turned ON too slowly.		The goal is to detect the error. (A preventative measure is not required.)	
Attached information	None					
Precautions/Remarks	"38" is displayed on the Servo Drive front panel and F038 is given as the AlarmCode (4001 hex).					

Event name	Drive Prohibition Input Error 2			Event code	64E10000 hex	
Meaning	An operation command (such as a trial run of FFT) was received from the CX-Drive when the Drive Prohibition Input Selection (3504 hex) was set to 0, EtherCAT communications was interrupted, and either POT or NOT was ON. Or, POT or NOT turned ON while operation was being performed for a CX-Drive operation command.					
Source	EtherCAT Master Function Module		Source details	Slave	Detection timing	Continuously
Error attributes	Level	Minor fault	Recovery	Error reset (after resetting slave errors)	Log category	System
Effects	User program	Continues.	Operation	Power drive circuit is OFF for relevant slave.		
Indicators	EtherCAT NET RUN		EtherCAT NET ERR		EtherCAT LINK/ACT	
	---		---		---	
System-defined variables	Variable		Data type		Name	
	None		---		---	
Cause and correction	Assumed cause		Remedy		Prevention	
	A problem occurred with the switches, wires, and power supplies that are connected to the Forward Drive Prohibition input or the Reverse Drive Prohibition input.		Remove the problem with the switches, wires, and power supplies that are connected to the Forward Drive Prohibition input or the Reverse Drive Prohibition input. In particular, check to see if the control signal power supply (12 to 24 VDC) turned ON too slowly.		The goal is to detect the error. (A preventative measure is not required.)	
Attached information	None					
Precautions/Remarks	"38" is displayed on the Servo Drive front panel and F138 is given as the AlarmCode (4001 hex).					

Event name	Immediate Stop Input Error		Event code	64E20000 hex		
Meaning	An Immediate Stop (STOP) signal was input.					
Source	EtherCAT Master Function Module		Source details	Slave	Detection timing	Continuously
Error attributes	Level	Minor fault	Recovery	Error reset (after resetting slave errors)	Log category	System
Effects	User program	Continues.	Operation	Power drive circuit is OFF for relevant slave.		
Indicators	EtherCAT NET RUN		EtherCAT NET ERR		EtherCAT LINK/ACT	
	---		---		---	
System-defined variables	Variable	Data type		Name		
	None		---		---	
Cause and correction	Assumed cause		Remedy		Prevention	
	An Immediate Stop (STOP) signal was input.		Clear the cause of the immediate stop input (STOP).		The goal is to detect the error. (A preventative measure is not required.)	
	Incorrect wiring of the immediate stop input (STOP).		Correct the wiring of the immediate stop input (STOP) if it is incorrect.		Make sure that the immediate stop input (STOP) wiring is incorrect.	
Attached information	None					
Precautions/Remarks	"87" is displayed on the Servo Drive front panel and F087 is given as the AlarmCode (4001 hex).					

Event name	Command Error		Event code	74810000 hex		
Meaning	A mistake was made in using a command.					
Source	EtherCAT Master Function Module		Source details	Slave	Detection timing	Continuously
Error attributes	Level	Minor fault	Recovery	Error reset (after resetting slave errors)	Log category	System
Effects	User program	Continues.	Operation	Power drive circuit is OFF for relevant slave.		
Indicators	EtherCAT NET RUN		EtherCAT NET ERR		EtherCAT LINK/ACT	
	---		---		---	
System-defined variables	Variable		Data type		Name	
	None		---		---	
Cause and correction	Assumed cause		Remedy		Prevention	
	When bit 09 (Remote) of the Statusword (6041 hex) was set to 1 (remote), and the Servo Drive was in operation enabled state (Servo ON), a command was received that changes the communications state from Operational to another state (Init, Pre-operational, or Safe-operational state).		Check the command specifications of the host controller and correct the command.		Check the command specifications of the host controller to use correct command.	
	When bit 09 (Remote) of the Statusword (6041 hex) was set to 0 (local), a command was received during FFT or test run status that changes the ESM state from Operational, Safe-operational, or Pre-operational state to Init state.					
	An unsupported number was set for 6060 hex (Operation Mode).					
	During Fully-closed Control Mode, csv or cst was set for 6060 hex (Operation Mode).					
	The setting of 6060 hex (Operation Mode) was changed at an interval of less than 2 ms.					
	Homing was started when 6098 hex (Homing Method) was set to a value other than 8, 12, 19, 20, 33, 34, or 35.					
	Data setting warnings (B0 hex) occurred continuously for the number of data setting warnings that is set in 3781 hex (Data Setting Warning Detection Count).					
Attached information	None					
Precautions/Remarks	"91" is displayed on the Servo Drive front panel and F191 is given as the AlarmCode (4001 hex).					

Event name	Operation Command Competition		Event code	78010000 hex		
Meaning	An attempt was made to establish EtherCAT communications or to turn ON the Servo from the Controller (enable operation) while executing an FFT that operates with the Servo Drive alone or a trial run.					
Source	EtherCAT Master Function Module		Source details	Slave	Detection timing	During independent slave operation
Error attributes	Level	Minor fault	Recovery	Error reset (after resetting slave errors)	Log category	System
Effects	User program	Continues.	Operation	Power drive circuit is OFF for relevant slave.		
Indicators	EtherCAT NET RUN		EtherCAT NET ERR		EtherCAT LINK/ACT	
	---		---		---	
System-defined variables	Variable		Data type		Name	
	None		---		---	
Cause and correction	Assumed cause		Remedy		Prevention	
	EtherCAT communications (change from Init to Pre-operational state) was established or an attempt to turn ON the Servo from the Controller (enable operation) was made while executing an FFT that operates with the Servo Drive trial run.		Do not establish EtherCAT communications while an FFT or a trial run is being performed. Do not turn ON the Servo (enable operation) while an FFT or a trial run is being performed.		Do not establish EtherCAT communications while an FFT or a trial run is being performed. Do not turn ON the Servo (enable operation) while an FFT or a trial run is being performed.	
Attached information	None					
Precautions/Remarks	“27” is displayed on the Servo Drive front panel and F627 is given as the AlarmCode (4001 hex)					

Event name	Absolute Encoder Status Error		Event code	78020000 hex		
Meaning	The rotation of the encoder was higher than the specified value when the power supply was turned ON.					
Source	EtherCAT Master Function Module		Source details	Slave	Detection timing	When establishing communications after turning ON power to the slave
Error attributes	Level	Minor fault	Recovery	Error reset (after cycling slave power)	Log category	System
Effects	User program	Continues.	Operation	Power drive circuit is OFF for relevant slave.		
Indicators	EtherCAT NET RUN		EtherCAT NET ERR		EtherCAT LINK/ACT	
	---		---		---	
System-defined variables	Variable		Data type		Name	
	None		---		---	
Cause and correction	Assumed cause		Remedy		Prevention	
	The rotation of the encoder was higher than the specified value when the power supply was turned ON.		Do not let the Servomotor move when the power supply is turned ON.		Do not let the Servomotor move when the power supply is turned ON.	
Attached information	None					
Precautions/Remarks	“47” is displayed on the Servo Drive front panel and F047 is given as the AlarmCode (4001 hex).					

Event name	EtherCAT State Change Error			Event code	84B10000 hex	
Meaning	A communications state change command was received for which the current communications state could not be changed.					
Source	EtherCAT Master Function Module		Source details	Slave	Detection timing	Continuously
Error attributes	Level	Minor fault	Recovery	Error reset (after resetting slave errors)	Log category	System
Effects	User program	Continues.	Operation	Power drive circuit is OFF for relevant slave.		
Indicators	EtherCAT NET RUN		EtherCAT NET ERR		EtherCAT LINK/ACT	
	---		Flashes at 1-s intervals.		---	
System-defined variables	Variable		Data type		Name	
	None		---		---	
Cause and correction	Assumed cause		Remedy		Prevention	
	A communications state change command was received for which the current communications state could not be changed.		Check the command specifications for communications state transitions in the host controller and correct host controller processing.		Check the command specifications for communications state transitions in the host controller and program host controller processing.	
Attached information	None					
Precautions/Remarks	"83" is displayed on the Servo Drive front panel and F183 is given as the AlarmCode (4001 hex).					

Event name	EtherCAT Illegal State Change Error			Event code	84B20000 hex	
Meaning	An undefined communications state change command was received.					
Source	EtherCAT Master Function Module		Source details	Slave	Detection timing	Continuously
Error attributes	Level	Minor fault	Recovery	Error reset (after resetting slave errors)	Log category	System
Effects	User program	Continues.	Operation	Power drive circuit is OFF for relevant slave.		
Indicators	EtherCAT NET RUN		EtherCAT NET ERR		EtherCAT LINK/ACT	
	---		Flashes at 1-s intervals.		---	
System-defined variables	Variable		Data type		Name	
	None		---		---	
Cause and correction	Assumed cause		Remedy		Prevention	
	An undefined communications state change command was received.		Check the command specifications for communications state transitions in the host controller and correct host controller processing.		Check the command specifications for communications state transitions in the host controller and program host controller processing.	
Attached information	None					
Precautions/Remarks	"83" is displayed on the Servo Drive front panel and F283 is given as the AlarmCode (4001 hex).					

Event name	Communications Synchronization Error			Event code	84B30000 hex	
Meaning	The number of consecutive errors in receiving data during the communication sync time exceeded the value specified for the Communications Error Setting (2200 hex)..					
Source	EtherCAT Master Function Module		Source details	Slave	Detection timing	Continuously
Error attributes	Level	Minor fault	Recovery	Error reset (after resetting slave errors)	Log category	System
Effects	User program	Continues.	Operation	Power drive circuit is OFF for relevant slave.		
Indicators	EtherCAT NET RUN		EtherCAT NET ERR		EtherCAT LINK/ACT	
	---		Flashes at 1-s intervals.		---	
System-defined variables	Variable		Data type		Name	
	None		---		---	
Cause and correction	Assumed cause		Remedy		Prevention	
	Power to the host controller was interrupted during PDO communications.		Reset the error in the host controller. This event reports an error that was detected when power to the host controller was interrupted. It does not indicate that an error currently exists.		If you turn OFF the power supply to the host controller, also turn OFF the power supply to the Servo Drive.	
	An EtherCAT communications cable is disconnected, broken, or incorrectly connected.		Connect the EtherCAT communications cable securely. If the cable is broken, replace it.		Connect the EtherCAT communications cable securely.	
	Noise		Take noise countermeasures if excessive noise is affecting the EtherCAT communications cable.		Take noise countermeasures if excessive noise is affecting the EtherCAT communications cable.	
Attached information	None					
Precautions/Remarks	"83" is displayed on the Servo Drive front panel and F383 is given as the AlarmCode (4001 hex).					

Event name	Synchronization Error			Event code	84B40000 hex	
Meaning	A synchronization error occurred.					
Source	EtherCAT Master Function Module		Source details	Slave	Detection timing	Continuously
Error attributes	Level	Minor fault	Recovery	Error reset (after resetting slave errors)	Log category	System
Effects	User program	Continues.	Operation	Power drive circuit is OFF for relevant slave.		
Indicators	EtherCAT NET RUN		EtherCAT NET ERR		EtherCAT LINK/ACT	
	---		Flashes at 1-s intervals.		---	
System-defined variables	Variable		Data type		Name	
	None		---		---	
Cause and correction	Assumed cause		Remedy		Prevention	
	Noise		Take noise countermeasures if excessive noise is affecting the EtherCAT communications cable.		Take noise countermeasures if excessive noise is affecting the EtherCAT communications cable.	
	Control PCB error		Replace the Servo Drive.		None	
Attached information	None					
Precautions/Remarks	"83" is displayed on the Servo Drive front panel and F483 is given as the AlarmCode (4001 hex).					

Event name	Sync Manager WDT Error			Event code	84B50000 hex	
Meaning	PDO communications were stopped for more than the specified period of time.					
Source	EtherCAT Master Function Module		Source details	Slave	Detection timing	Continuously
Error attributes	Level	Minor fault	Recovery	Error reset (after resetting slave errors)	Log category	System
Effects	User program	Continues.	Operation	Power drive circuit is OFF for relevant slave.		
Indicators	EtherCAT NET RUN		EtherCAT NET ERR		EtherCAT LINK/ACT	
	---		Flashes at 1-s intervals.		---	
System-defined variables	Variable		Data type		Name	
	None		---		---	
Cause and correction	Assumed cause		Remedy		Prevention	
	The EtherCAT communications cable is disconnected or broken.		Connect the EtherCAT communications cable securely.		Connect the EtherCAT communications cable securely.	
	There is an error in the host controller.		Check the operation of the host controller and take appropriate measures if there a problem.		None	
Attached information	None					
Precautions/Remarks	"83" is displayed on the Servo Drive front panel and F583 is given as the AlarmCode (4001 hex).					

Event name	ESC Initialization Error			Event code	84B60000 hex	
Meaning	An error occurred in ESC initialization.					
Source	EtherCAT Master Function Module		Source details	Slave	Detection timing	When establishing communications after turning ON power to the slave
Error attributes	Level	Minor fault	Recovery	Error reset (after cycling slave power)	Log category	System
Effects	User program	Continues.	Operation	Power drive circuit is OFF for relevant slave.		
Indicators	EtherCAT NET RUN		EtherCAT NET ERR		EtherCAT LINK/ACT	
	---		---		---	
System-defined variables	Variable		Data type		Name	
	None		---		---	
Cause and correction	Assumed cause		Remedy		Prevention	
	Control PCB error		Replace the Servo Drive.		None	
Attached information	None					
Precautions/Remarks	"88" is displayed on the Servo Drive front panel and F188 is given as the AlarmCode (4001 hex).					

Event name	Slave Unit Verification Error			Event code	84B70000 hex	
Meaning	An error occurred in Slave Unit verification.					
Source	EtherCAT Master Function Module		Source details	Slave	Detection timing	When establishing communications after turning ON power to the slave
Error attributes	Level	Minor fault	Recovery	Error reset (after cycling slave power)	Log category	System
Effects	User program	Continues.	Operation	Power drive circuit is OFF for relevant slave.		
Indicators	EtherCAT NET RUN		EtherCAT NET ERR		EtherCAT LINK/ACT	
	---		Flashes at 1-s intervals.		---	
System-defined variables	Variable		Data type		Name	
	None		---		---	
Cause and correction	Assumed cause		Remedy		Prevention	
	Control PCB error		Replace the Servo Drive.		None	
Attached information	None					
Precautions/Remarks	"88" is displayed on the Servo Drive front panel and F388 is given as the AlarmCode (4001 hex).					

Event name	Communications Setting Error			Event code	84B80000 hex	
Meaning	There is an error in the communications settings.					
Source	EtherCAT Master Function Module		Source details	Slave	Detection timing	Continuously
Error attributes	Level	Minor fault	Recovery	Error reset (after resetting slave errors)	Log category	System
Effects	User program	Continues.	Operation	Power drive circuit is OFF for relevant slave.		
Indicators	EtherCAT NET RUN		EtherCAT NET ERR		EtherCAT LINK/ACT	
	---		Flashes at 1-s intervals.		---	
System-defined variables	Variable		Data type		Name	
	None		---		---	
Cause and correction	Assumed cause		Remedy		Prevention	
	An out-of-range value was set from the host controller.		Set EtherCAT communications parameters so that the synchronous cycle (SYNC0 cycle) and other setting are within the specified ranges.		Set EtherCAT communications parameters so that the synchronous cycle (SYNC0 cycle) and other setting are within the specified ranges.	
	A command that changes the communications state to an unsupported state was received.		Check the command specifications for communications state transitions in the host controller and correct host controller processing.		Check the command specifications for communications state transitions in the host controller and program host controller processing.	
Attached information	None					
Precautions/Remarks	"90" is displayed on the Servo Drive front panel and F090 is given as the AlarmCode (4001 hex).					

Event name	Synchronization Interruption Error			Event code	84B90000 hex	
Meaning	A synchronization interruption error occurred.					
Source	EtherCAT Master Function Module		Source details	Slave	Detection timing	Continuously
Error attributes	Level	Minor fault	Recovery	Error reset (after cycling slave power)	Log category	System
Effects	User program	Continues.	Operation	Power drive circuit is OFF for relevant slave.		
Indicators	EtherCAT NET RUN		EtherCAT NET ERR		EtherCAT LINK/ACT	
	---		Flashes at 1-s intervals.		---	
System-defined variables	Variable		Data type		Name	
	None		---		---	
Cause and correction	Assumed cause		Remedy		Prevention	
	Control PCB error		Replace the Servo Drive.		None	
Attached information	None					
Precautions/Remarks	"88" is displayed on the Servo Drive front panel and F288 is given as the AlarmCode (4001 hex)					

Event name	Absolute Value Cleared			Event code	98010000 hex	
Meaning	The multi-rotation counter for the absolute encoder was cleared during USB communications by the CX-Drive.					
Source	EtherCAT Master Function Module		Source details	Slave	Detection timing	Continuously
Error attributes	Level	Minor fault	Recovery	Error reset (after cycling slave power)	Log category	System
Effects	User program	Continues.	Operation	Power drive circuit is OFF for relevant slave.		
Indicators	EtherCAT NET RUN		EtherCAT NET ERR		EtherCAT LINK/ACT	
	---		---		---	
System-defined variables	Variable		Data type		Name	
	None		---		---	
Cause and correction	Assumed cause		Remedy		Prevention	
	The multi-rotation counter for the absolute encoder was cleared during USB communications by the CX-Drive.		This operation is performed for safety and is not an error.		(A preventative measure is not required because this is a safety measure.)	
Attached information	None					
Precautions/Remarks	"27" is displayed on the Servo Drive front panel and F127 is given as the AlarmCode (4001 hex)					

Event name	Position Data Initialized		Event code	98020000 hex		
Meaning	A Config operation was performed or the multi-rotation counter was cleared for the absolute encoder during EtherCAT communications.					
Source	EtherCAT Master Function Module		Source details	Slave	Detection timing	Continuously
Error attributes	Level	Minor fault	Recovery	Error reset (after resetting slave errors)	Log category	System
Effects	User program	Continues.	Operation	Power drive circuit is OFF for relevant slave.		
Indicators	EtherCAT NET RUN		EtherCAT NET ERR		EtherCAT LINK/ACT	
	---		---		---	
System-defined variables	Variable		Data type		Name	
	None		---		---	
Cause and correction	Assumed cause		Remedy		Prevention	
	A Config operation was performed or the multi-rotation counter was cleared for the absolute encoder during EtherCAT communications.		This operation is performed for safety and is not an error.		(A preventative measure is not required because this is a safety measure.)	
Attached information	None					
Precautions/Remarks	"27" is displayed on the Servo Drive front panel and F727 is given as the AlarmCode (4001 hex)					

Event name	Battery Warning		Event code	08010000 hex		
Meaning	The battery voltage is 3.2 V or less.					
Source	EtherCAT Master Function Module		Source details	Slave	Detection timing	Continuously
Error attributes	Level	Observation	Recovery	---	Log category	System
Effects	User program	Continues.	Operation	Not affected.		
Indicators	EtherCAT NET RUN		EtherCAT NET ERR		EtherCAT LINK/ACT	
	---		---		---	
System-defined variables	Variable		Data type		Name	
	None		---		---	
Cause and correction	Assumed cause		Remedy		Prevention	
	The battery voltage is 3.2 V or lower.		Replace the Battery and reset the slave error.		Periodically replace the Battery.	
Attached information	None					
Precautions/Remarks	"A2" is displayed on the front panel of the Servo Drive.					

Event name	Fan Warning			Event code	08020000 hex	
Meaning	The fan stop state continued for 1 second.					
Source	EtherCAT Master Function Module		Source details	Slave	Detection timing	Continuously
Error attributes	Level	Observation	Recovery	---	Log category	System
Effects	User program	Continues.	Operation	Not affected.		
Indicators	EtherCAT NET RUN		EtherCAT NET ERR		EtherCAT LINK/ACT	
	---		---		---	
System-defined variables	Variable		Data type		Name	
	None		---		---	
Cause and correction	Assumed cause		Remedy		Prevention	
	There is foreign matter in the fan.		If there is foreign matter in the fan, remove it.		Do not use the fan in an area surrounded by excessive foreign matter. Also, do not allow foreign objects to enter.	
	The Servo Drive failed.		If the above cause is not the cause of the problem, replace the Servo Drive.		None	
Attached information	None					
Precautions/Remarks	"A3" is displayed on the front panel of the Servo Drive.					

Event name	Encoder Communications Warning			Event code	08030000 hex	
Meaning	Encoder communications errors occurred in series more frequently than the specified value.					
Source	EtherCAT Master Function Module		Source details	Slave	Detection timing	Continuously
Error attributes	Level	Observation	Recovery	---	Log category	System
Effects	User program	Continues.	Operation	Not affected.		
Indicators	EtherCAT NET RUN		EtherCAT NET ERR		EtherCAT LINK/ACT	
	---		---		---	
System-defined variables	Variable		Data type		Name	
	None		---		---	
Cause and correction	Assumed cause		Remedy		Prevention	
	There is insufficient power supply voltage for the encoder.		Provide the required encoder power supply voltage of 5 VDC \pm 5% (4.75 to 5.25 V). Be careful especially of voltage drop when the encoder cable is long.		Provide the required encoder power supply voltage of 5 VDC \pm 5% (4.75 to 5.25 V). Be careful especially of voltage drop when the encoder cable is long.	
	Noise is entering on the encoder line.		If the Servomotor cable and the encoder cable are bundled together, separate them. Connect the shield to FG.		If the Servomotor cable and the encoder cable are bundled together, separate them. Connect the shield to FG.	
Attached information	None					
Precautions/Remarks	"A4" is displayed on the front panel of the Servo Drive.					

Event name	Encoder Overheating Warning			Event code	08040000 hex	
Meaning	The encoder temperature exceeded the specified value.					
Source	EtherCAT Master Function Module		Source details	Slave	Detection timing	Continuously
Error attributes	Level	Observation	Recovery	---	Log category	System
Effects	User program	Continues.	Operation	Not affected.		
Indicators	EtherCAT NET RUN		EtherCAT NET ERR		EtherCAT LINK/ACT	
	---		---		---	
System-defined variables	Variable		Data type		Name	
	None		---		---	
Cause and correction	Assumed cause		Remedy		Prevention	
	The ambient temperature is too high.		Remove the cause of encoder overheating.		Adjust the surrounding environment so that the encoder does not overheat.	
	Servomotor failed.		Replace the Servomotor.		None	
Attached information	None					
Precautions/Remarks	“A5” is displayed on the front panel of the Servo Drive.					

Event name	Life Expectancy Warning			Event code	08050000 hex	
Meaning	The remaining life of the capacitor or the fan is shorter than the specified value.					
Source	EtherCAT Master Function Module		Source details	Slave	Detection timing	Continuously
Error attributes	Level	Observation	Recovery	---	Log category	System
Effects	User program	Continues.	Operation	Not affected.		
Indicators	EtherCAT NET RUN		EtherCAT NET ERR		EtherCAT LINK/ACT	
	---		---		---	
System-defined variables	Variable		Data type		Name	
	None		---		---	
Cause and correction	Assumed cause		Remedy		Prevention	
	The life expectancy of the capacitor or the fan is shorter than the specified value.		Replace the Servo Drive.		None	
Attached information	None					
Precautions/Remarks	“A7” is displayed on the front panel of the Servo Drive.					

Event name	External Encoder Error Warning			Event code	08060000 hex	
Meaning	The external encoder detected a warning.					
Source	EtherCAT Master Function Module		Source details	Slave	Detection timing	Continuously
Error attributes	Level	Observation	Recovery	---	Log category	System
Effects	User program	Continues.	Operation	Not affected.		
Indicators	EtherCAT NET RUN		EtherCAT NET ERR		EtherCAT LINK/ACT	
	---		---		---	
System-defined variables	Variable		Data type		Name	
	None		---		---	
Cause and correction	Assumed cause		Remedy		Prevention	
	There is insufficient power supply voltage for the external encoder.		Provide the required external encoder power supply voltage of 5 VDC $\pm 5\%$ (4.75 to 5.25 V).		Provide the required external encoder power supply voltage of 5 VDC $\pm 5\%$ (4.75 to 5.25 V).	
	Noise is entering on the external encoder connector cable.		If the Servomotor cable and the external encoder cable are bundled together, separate them. Connect the shield to FG.		If the Servomotor cable and the external encoder cable are bundled together, separate them. Connect the shield to FG.	
	The external encoder failed.		If none of the above causes applies, replace the external encoder.		None	
Attached information	None					
Precautions/Remarks	"A8" is displayed on the front panel of the Servo Drive.					

Event name	External Encoder Communications Warning			Event code	08070000 hex	
Meaning	The external encoder had more communications errors than the specified value.					
Source	EtherCAT Master Function Module		Source details	Slave	Detection timing	Continuously
Error attributes	Level	Observation	Recovery	---	Log category	System
Effects	User program	Continues.	Operation	Not affected.		
Indicators	EtherCAT NET RUN		EtherCAT NET ERR		EtherCAT LINK/ACT	
	---		---		---	
System-defined variables	Variable		Data type		Name	
	None		---		---	
Cause and correction	Assumed cause		Remedy		Prevention	
	There is insufficient power supply voltage for the external encoder.		Provide the required external encoder power supply voltage of 5 VDC $\pm 5\%$ (4.75 to 5.25 V).		Provide the required external encoder power supply voltage of 5 VDC $\pm 5\%$ (4.75 to 5.25 V).	
	Noise is entering on the external encoder connector cable.		If the Servomotor cable and the external encoder cable are bundled together, separate them. Connect the shield to FG.		If the Servomotor cable and the external encoder cable are bundled together, separate them. Connect the shield to FG.	
Attached information	None					
Precautions/Remarks	"A9" is displayed on the front panel of the Servo Drive.					

Event name	Data Setting Warning			Event code	34E00000 hex	
Meaning	An object setting is out of range.					
Source	EtherCAT Master Function Module		Source details	Slave	Detection timing	Continuously
Error attributes	Level	Observation	Recovery	---	Log category	System
Effects	User program	Continues.	Operation	Not affected.		
Indicators	EtherCAT NET RUN		EtherCAT NET ERR		EtherCAT LINK/ACT	
	---		---		---	
System-defined variables	Variable		Data type		Name	
	None		---		---	
Cause and correction	Assumed cause		Remedy		Prevention	
	An object setting is out of range.		Correct the object settings so that they are within the specified ranges.		Set the object settings so that they are within the specified ranges.	
Attached information	None					
Precautions/Remarks	"B0" is displayed on the front panel of the Servo Drive.					

Event name	Overload Warning			Event code	383C0000 hex	
Meaning	The load ratio is 85% or more of the protection level.					
Source	EtherCAT Master Function Module		Source details	Slave	Detection timing	While power is supplied to motor
Error attributes	Level	Observation	Recovery	---	Log category	System
Effects	User program	Continues.	Operation	Not affected.		
Indicators	EtherCAT NET RUN		EtherCAT NET ERR		EtherCAT LINK/ACT	
	---		---		---	
System-defined variables	Variable		Data type		Name	
	None		---		---	
Cause and correction	Assumed cause		Remedy		Prevention	
	Overload		<p>Take the following actions according to the situation.</p> <ul style="list-style-type: none"> • Increase the capacities of the Servo Drive and the Servomotor. • Increase the setting of the acceleration/deceleration time and lighten the load. • Adjust the gain or inertial ratio. • Remove machine distortion. • Measure the voltage at the brake terminal. If the brake is ON, release it. • Correct the system if torque (current) waveforms oscillate or excessively oscillate vertically during analog output or communications. 		<p>Check the items given for corrections in advance and implement countermeasures as required.</p>	
	There is incorrect wiring of the motor line or a broken cable.		Connect the Servomotor cable as shown in the wiring diagram. If the cable is broken, replace it. Connect the motor line and encoder line that are used together to the same motor.		Connect the Servomotor cable as shown in the wiring diagram. Connect the motor line and encoder line that are used together to the same motor.	
Attached information	None					
Precautions/Remarks	"A0" is displayed on the front panel of the Servo Drive.					

Event name	Excessive Regeneration Warning			Event code	383D0000 hex	
Meaning	The regeneration load ratio is 85% or more of the level.					
Source	EtherCAT Master Function Module		Source details	Slave	Detection timing	While power is supplied to motor
Error attributes	Level	Observation	Recovery	---	Log category	System
Effects	User program	Continues.	Operation	Not affected.		
Indicators	EtherCAT NET RUN		EtherCAT NET ERR		EtherCAT LINK/ACT	
	---		---		---	
System-defined variables	Variable		Data type		Name	
	None		---		---	
Cause and correction	Assumed cause		Remedy		Prevention	
	There is excessive regeneration.		<p>Check the operation pattern (velocity monitor). Check the Regeneration Resistor load rate and the excessive regeneration warning, and perform the following accordingly.</p> <ul style="list-style-type: none"> • Increase the capacities of the Servomotor and the Servo Drive. • Increase the deceleration time. • Reduce the Servomotor rotation speed. • Use an External Regeneration Resistor. • Set the Regeneration Resistor Selection (3016 hex) to 2. 		<p>Check the items given for corrections in advance and implement countermeasures as required. Or, set the Regeneration Resistor Selection (3016 hex) to 2.</p>	
	This Regeneration Resistor cannot be used for continuous regenerative braking.		This Regeneration Resistor cannot be used for continuous regenerative braking.		Do not use the Regeneration Resistor for continuous regenerative braking.	
Attached information	None					
Precautions/Remarks	“A1” is displayed on the front panel of the Servo Drive.					

Event name	Vibration Detection Warning			Event code	383E0000 hex	
Meaning	Vibration was detected.					
Source	EtherCAT Master Function Module		Source details	Slave	Detection timing	While power is supplied to motor
Error attributes	Level	Observation	Recovery	---	Log category	System
Effects	User program	Continues.	Operation	Not affected.		
Indicators	EtherCAT NET RUN		EtherCAT NET ERR		EtherCAT LINK/ACT	
	---		---		---	
System-defined variables	Variable		Data type		Name	
	None		---		---	
Cause and correction	Assumed cause		Remedy		Prevention	
	The gain or inertial ratio setting is not suitable.		Correct the gain (the balance between position loop gain and velocity loop gain) and the inertial ratio.		Adjust the gain (the balance between position loop gain and velocity loop gain) and the inertial ratio.	
Attached information	None					
Precautions/Remarks	“A6” is displayed on the front panel of the Servo Drive.					

Event name	Command Warning		Event code	74800000 hex		
Meaning	A command could not be executed.					
Source	EtherCAT Master Function Module		Source details	Slave	Detection timing	Continuously
Error attributes	Level	Observation	Recovery	---	Log category	System
Effects	User program	Continues.	Operation	Not affected.		
Indicators	EtherCAT NET RUN		EtherCAT NET ERR		EtherCAT LINK/ACT	
	---		---		---	
System-defined variables	Variable		Data type		Name	
	None		---		---	
Cause and correction	Assumed cause		Remedy		Prevention	
	The absolute multi-rotation counter was cleared when the Servo was not OFF when using an absolute encoder for semi-closed control.		Make sure that the settings meet the object's operation conditions. Check the drive prohibition input and operation command, and take actions accordingly.		Make sure that the settings meet the object's operation conditions. Check the drive prohibition input and operation command, and take actions accordingly.	
	A forced brake operation request was sent while the Servo was ON.					
	A Switch ON command was sent when the main power was OFF. (When 3508 hex = 0)					
	An Enable Operation command was sent to request turning ON the Servo when the Servomotor was operating at 30 r/min or higher.					
	A latch operation was started under the following conditions. <ul style="list-style-type: none"> An absolute external encoder was used and phase Z was selected as the trigger for fully-closed control. The absolute multi-rotation data was being cleared or the Config operation was being performed. The Statusword (6041 hex) bit 09 (remote) was 0 (local). 					
An operation command is given in the prohibited direction after the motor made an immediate stop due to a drive prohibition input.						
Attached information	None					
Precautions/Remarks	"B1" is displayed on the front panel of the Servo Drive.					

Event name	EtherCAT Communications Warning		Event code	84B00000 hex	
Meaning	An EtherCAT communications error occurred one or more times.				
Source	EtherCAT Master Function Module	Source details	Slave	Detection timing	Continuously
Error attributes	Level	Observation	Recovery	---	Log category System
Effects	User program	Continues.	Operation	Not affected.	
Indicators	EtherCAT NET RUN		EtherCAT NET ERR		EtherCAT LINK/ACT
	---		---		---
System-defined variables	Variable		Data type		Name
	None		---		---
Cause and correction	Assumed cause		Remedy		Prevention
	The EtherCAT communications cable is disconnected or broken.		Connect the EtherCAT communications cable securely. If the cable is broken, replace it.		Connect the EtherCAT communications cable securely.
	Noise		Take noise countermeasures if excessive noise is affecting the EtherCAT communications cable.		Take noise countermeasures if excessive noise is affecting the EtherCAT communications cable.
Attached information	None				
Precautions/Remarks	"B2" is displayed on the front panel of the Servo Drive.				

A-4 EtherCAT Terminology

Use the following list of EtherCAT terms for reference.

Term	Abbreviation	Description
object	–	Abstract representation of a particular component within a device, which consists of data, parameters, and methods.
object dictionary	OD	Data structure addressed by Index and Subindex that contains description of data type objects, communication objects and application objects.
service data object	SDO	CoE asynchronous mailbox communications where all objects in the object dictionary can be read and written.
index	–	Address of an object within an application process.
subindex	–	Sub-address of an object within the object dictionary.
process data	–	Collection of application objects designated to be transferred cyclically or acyclically for the purpose of measurement and control.
process data object	PDO	Structure described by mapping parameters containing one or several process data entities.
Receive PDO	RxPDO	A process data object received by an EtherCAT slave.
Transmit PDO	TxPDO	A process data object sent from an EtherCAT slave.
sync manager	SM	Collection of control elements to coordinate access to concurrently used objects.
distributed clock	DC	Method to synchronize slaves and maintain a global time base.
device profile	–	Collection of device dependent information and functionality providing consistency between similar devices of the same device type.
fieldbus memory management unit	FMMU	Single element of the fieldbus memory management unit: one correspondence between a coherent logical address space and a coherent physical memory location.
physical device internal interface	PDI	A series of elements to access data link services from the application layer.
CAN in Automation	CiA	CiA is the international users' and manufacturers' group that develops and supports higher-layer protocols.
CAN application protocol over EtherCAT	CoE	A CAN application protocol service implemented on EtherCAT.
EEPROM	EEPROM	Electrically erasable PROM.
EtherCAT Technology Group	ETG	The ETG is a global organization in which OEM, End Users and Technology Providers join forces to support and promote the further technology development.
EtherCAT slave controller	ESC	A controller for EtherCAT slave communication.
EtherCAT state machine	ESM	An EtherCAT communication state machine.
EtherCAT slave information	ESI	An XML file that contains setting information for an EtherCAT slave.
Slave Information Interface	SII	Slave information stored in the nonvolatile memory of each slave.
Power Drive System	PDS	A power drive system consisting of a Servo Drive, an inverter, and other components.

A-5 Functional Differences among Unit Versions

The following table shows the functional differences among unit versions.

Item		Unit version		
		Ver.1.0	Ver.2.0	Ver.2.1
Servo Drive model		R88D-KN□-ECT-R	R88D-KN□-ECT	
Sysmac Device Features	Sysmac Error Status	Not supported		Supported
	Saving the Node Address Setting	Not supported		Supported
	Serial Number Display*1	Not supported		Supported
	ESI Specification (Version 1.0)	Not supported		Supported
	SII Data Check	Not supported		Supported
Fixed PDO mapping		Not supported	Supported	
Variable PDO mapping (1600 hex, 1A00 hex)		Not supported		Supported
Available operation modes	csp: Cyclic synchronous position mode	Supported		
	csv: Cyclic synchronous velocity mode	Not supported	Supported	
	cst: Cyclic synchronous torque mode	Not supported	Supported	
	pp: Profile position mode	Not supported		Supported
	hm: Homing mode	Not supported	Supported	
FIR filter function		Not supported	Supported*2 (Available when the communications cycle is 1 ms or above)	
Error detection function	Excessive Speed Deviation Error	Not supported	Supported	
	Interruptions Error	Not supported	Supported	
Electronic gear function		Supported	Not supported*3 (only to 1:1)	Supported
Fully-closed Control*4		Supported	Available when the communications cycle is 500 μs or above in csp and 1 ms or above in hm.	csp: Available when the communications cycle is 500 μs or above at an electronic gear ratio of 1:1 and 1 ms or above at a gear ratio other than 1:1. pp, hm: Available when the communications cycle is 1 ms or above at an electronic gear ratio of 1:1 and 2 ms or above at a gear ratio other than 1:1.*5
Torque limit objects		PDO mapping to 60E0/60E1 hex is not possible.	PDO mapping to 60E0/60E1 hex is possible.*6	
Positioning Completion Range (6067 hex)		Disabled		Enabled
Reference Position for CSP (4020 hex)		Not supported		Supported
Data Setting Warning Detection Setting (3781 hex)		Not supported		Supported
DC power input		Not supported		Supported*7
Reference manual		I573	I576	

*1 The function to show the serial number controlled by OMRON in 1018h-04 hex.
 *2 Setting the communications cycle to 500 μs or less does not enable the FIR filter function, although doing so does not cause any error.
 *3 Setting this to an electronic gear ratio other than 1:1 simply causes the G5-series AC Servo Drive to operate at 1:1 without any errors.
 *4 If Fully-closed Control is not available, a Function Setting Error (Error No. 93.4) will occur.
 *5 This is applicable only when the total size of the objects mapped to RxPDO is 12 bytes or less. For details, refer to A-1-3 *Communications Cycles and Corresponding Modes of Operation*.
 *6 There are objects added (3013 hex/3522 hex) to or renamed (3525 hex/3526 hex) from unit version 1.0. For details of these objects, refer to Torque Limit Selection (3521 hex) in Extended Objects of each manual.
 *7 Only the following Servo Drive models support DC power input:
 • R88D-KN75H-ECT • R88D-KN150H-ECT



Index



Index

Numerics

1,000-r/min Servomotors	
model table	2-13
rotation speed characteristics	3-57
Servo Drives	2-16
1,500-r/min, 2,000-r/min Servomotors	
model table	2-11
rotation speed characteristics	3-52
Servo Drives	2-15
3,000-r/min Servomotors	
model table	2-9
rotation speed characteristics	3-43
Servo Drives	2-14
7-Segment Display	10-5

A

absolute encoder	
backup battery	2-25
battery cables	2-25
battery replacement	12-38
setup	10-7
specifications	3-59
Accessories	1-12
adaptive filter	11-20
analog control objects	
External Feedback Pulse Direction Switching (3326 hex)	9-29
External Feedback Pulse Dividing Denominator (3325 hex)	9-29
External Feedback Pulse Dividing Numerator (3324 hex)	9-29
External Feedback Pulse Phase-Z Setting (3327 hex)	9-30
External Feedback Pulse Type Selection (3323 hex)	9-28
Hybrid Following Error Counter Overflow Level (3328 hex)	9-30
Hybrid Following Error Counter Reset (3329 hex) ..	9-30
S-curve Acceleration/Deceleration Time Setting (3314 hex)	9-27
Soft Start Acceleration Time (3312 hex)	9-26
Soft Start Deceleration Time (3313 hex)	9-26
Speed Limit Selection (3317 hex)	9-27
Speed Limit Value Setting (3321 hex)	9-27
analog monitor	11-2
Analog Monitor Cable	2-25, 3-97
analog monitor connector specifications (CN5)	3-31
applicable standards	1-16

B

backlash compensation	7-13
-----------------------------	------

Backup Battery Inputs (BAT)	3-23
basic settings	
Control Mode Selection (3001 hex)	9-3
External Regeneration Resistor Setting (3017 hex) ..	9-6
External Torque Limit 1 (3013 hex)	9-5
Inertia Ratio (3004 hex)	9-4
Operation Switch when Using Absolute Encoder (3015 hex)	9-5
Realtime Autotuning Machine Rigidity Setting (3003 hex)	9-4
Realtime Autotuning Mode Selection (3002 hex)	9-3
Regeneration Resistor Selection (3016 hex)	9-6
Rotation Direction Switching (3000 hex)	9-2
Bend Radius of Robot Cable	3-67
Brake Cable Connector	3-93
brake cables (Robot Cable)	2-25
brake cables (Standard Cable)	2-22
brake interlock	7-15
Brake Interlock Output (BKIR)	3-25
brake power supply	4-47

C

CAN application protocol over EtherCAT	5-4
clamp core	4-48
communication objects	A-24
Backup Parameters Mode (10F0 hex)	A-29
Device Type (1000 hex)	A-24
Diagnosis History (10F3 hex)	A-29
Error Register (1001 hex)	A-25
Identity Object (1018 hex)	A-28
Manufacturer Device Name (1008 hex)	A-25
Manufacturer Hardware Version (1009 hex)	A-26
Manufacturer Software Version (100A hex)	A-26
Restore Default Parameters (1011 hex)	A-27
Store Parameters (1010 hex)	A-26
Completion	9-35
connectors	
model list	2-26
Connector-terminal Block	2-26
Connector-terminal Block Cables	2-26
Connector-Terminal Block Conversion Unit	3-100
contactors	4-51
control cables	
model list	2-26
control circuit connector specifications (CNC)	3-13, 4-26
Control effort (60FA hex)	A-72
control I/O connector specifications	3-91
control I/O signal	
connections and external signal processing	3-18
connectors	3-20
control input table	3-19
control output table	3-19
pin arrangement	3-20
control input circuits	3-21

control output circuits	3-23
control output sequence	3-24
control panel structure	4-43
Cyclic synchronous position mode	6-2
Cyclic synchronous torque mode	6-8
Cyclic synchronous velocity mode	6-5

D

damping control	11-17
Data Setting Warning Detection Setting	9-57
DC Power input	4-63
decelerator	
installation conditions	4-6
distributed clock (DC)	5-13
disturbance observer function	11-26

E

EC Directives	1-16
EDM output	8-4
EDM output circuit	3-34
electronic gear function	7-21
emergency messages	5-14
encoder	
specifications	3-59
encoder cable	
noise resistance	4-52
encoder cable specifications	3-69
encoder cables (Robot Cable)	2-23
encoder cables (Standard Cable)	2-20, 3-69
encoder connector specifications (CN2)	3-28
encoder connectors	3-91
Error Clear Attribute Output (ALM-ATB)	3-27
error list	12-9
Error Output (/ALM)	3-25
ESI (V1.0)	5-16
EtherCAT	1-3
command coding	A-3
communications cable	2-25
communications cycle	5-13
communications specifications	3-7
Cyclic synchronous position mode	6-2
state coding	A-4
state descriptions	A-3
terminology	A-168
EtherCAT Slave Information file	5-2
EtherCAT State Machine	5-5
Event code	
04A80000 hex	A-94, A-109
04A90000 hex	A-94, A-110
04AA0000 hex	A-95, A-111
04AB0000 hex	A-95, A-112
04AC0000 hex	A-95, A-113
04AD0000 hex	A-96, A-114
04AE0000 hex	A-96, A-115
04AF0000 hex	A-96, A-115
04B00000 hex	A-96, A-116
04B10000 hex	A-96, A-116

08010000 hex	A-106, A-160
08020000 hex	A-106, A-161
08030000 hex	A-106, A-161
08040000 hex	A-106, A-162
08050000 hex	A-106, A-162
08060000 hex	A-106, A-163
08070000 hex	A-106, A-163
08080000 hex	A-96, A-117
08090000 hex	A-96, A-117
080A0000 hex	A-96, A-118
080B0000 hex	A-96, A-118
080C0000 hex	A-97, A-119
080D0000 hex	A-97, A-119
080E0000 hex	A-97, A-120
080F0000 hex	A-97, A-120
08100000 hex	A-97, A-121
08110000 hex	A-97, A-121
08120000 hex	A-97, A-122
08130000 hex	A-97, A-122
08140000 hex	A-97, A-123
08150000 hex	A-97, A-123
08160000 hex	A-97, A-124
08170000 hex	A-98, A-124
08180000 hex	A-98, A-125
14A80000 hex	A-98, A-125
14A90000 hex	A-98, A-126
14AA0000 hex	A-98, A-126
14AB0000 hex	A-98, A-127
14AC0000 hex	A-98, A-127
14AD0000 hex	A-98, A-128
18200000 hex	A-98, A-128
18210000 hex	A-98, A-129
18220000 hex	A-98, A-129
18230000 hex	A-98, A-130
24680000 hex	A-99, A-130
24690000 hex	A-99, A-131
246A0000 hex	A-99, A-131
246B0000 hex	A-99, A-132
246C0000 hex	A-99, A-132
34E00000 hex	A-106, A-164
34E10000 hex	A-99, A-133
34E20000 hex	A-99, A-134
34E30000 hex	A-99, A-135
34E40000 hex	A-99, A-136
34E50000 hex	A-100, A-137
34E60000 hex	A-100, A-137
383C0000 hex	A-106, A-164
383D0000 hex	A-106, A-165
383E0000 hex	A-107, A-165
383F0000 hex	A-100, A-138
38400000 hex	A-100, A-139
38410000 hex	A-100, A-139
38420000 hex	A-100, A-140
38430000 hex	A-100, A-140
38440000 hex	A-101, A-141
38450000 hex	A-101, A-141
38460000 hex	A-101, A-142
38470000 hex	A-101, A-143
38480000 hex	A-101, A-144

- 38490000 hex A-101, A-145
 - 384A0000 hex A-101, A-145
 - 384B0000 hex A-101, A-146
 - 384C0000 hex A-102, A-146
 - 384D0000 hex A-102, A-147
 - 384E0000 hex A-102, A-148
 - 384F0000 hex A-102, A-148
 - 38500000 hex A-102, A-149
 - 38510000 hex A-102, A-149
 - 38520000 hex A-103, A-150
 - 64E00000 hex A-103, A-151
 - 64E10000 hex A-104, A-151
 - 64E20000 hex A-104, A-152
 - 74800000 hex A-107, A-166
 - 74810000 hex A-104, A-153
 - 78010000 hex A-105, A-154
 - 78020000 hex A-105, A-154
 - 84B00000 hex A-107, A-167
 - 84B10000 hex A-105, A-155
 - 84B20000 hex A-105, A-155
 - 84B30000 hex A-105, A-156
 - 84B40000 hex A-105, A-156
 - 84B50000 hex A-105, A-157
 - 84B60000 hex A-105, A-157
 - 84B70000 hex A-105, A-158
 - 84B80000 hex A-105, A-158
 - 84B90000 hex A-106, A-159
 - 98010000 hex A-106, A-159
 - 98020000 hex A-106, A-160
 - extended objects
 - Control Input Signal Read Setting (3515 hex) 9-44
 - Drive Prohibition Input Selection (3504 hex) 9-41
 - External Torque Limit 2 (3522 hex) 9-46
 - Forward External Torque Limit (3525 hex) 9-46
 - Immediate Stop Torque (3511 hex) 9-43
 - Momentary Hold Time (3509 hex) 9-43
 - Overload Detection Level Setting (3512 hex) 9-43
 - Overrun Limit Setting (3514 hex) 9-43
 - Overspeed Detection Level Setting (3513 hex) 9-43
 - Position Setting Unit Selection (3520 hex) 9-44
 - Reverse External Torque Limit (3526 hex) 9-46
 - Stop Selection for Drive Prohibition Input
(3505 hex) 9-42
 - Torque Limit Selection (3521 hex) 9-45
 - Undervoltage Error Selection (3508 hex) 9-42
 - external device monitor (EDM) output signal 8-4
 - external encoder
 - example of connection 3-29
 - input signal table 3-29
 - External Encoder Connector 3-98
 - external encoder connector specifications (CN4) 3-28
 - External Feedback Pulse Dividing Ratio Setting 6-20
 - External Latch Input Signals (EXT1, EXT2 and EXT3) 3-22
 - External Regeneration Resistor 4-59
 - combining 4-61
 - connecting 4-60
 - dimensions 2-86
 - model list 2-26
 - specifications 3-104
 - External Regeneration Resistor connector specifications
(CNC) 3-9, 4-22
 - External Regeneration Resistor connector specifications
(CND) 3-13, 4-26
 - External Torque Limit Input (NCL) 3-23
- ## F
-
- feed-forward function 11-31
 - fixed PDO mapping 5-7
 - forward drive prohibition function 7-8
 - Forward Drive Prohibition Input (POT) 3-22
 - Forward External Torque Limit Input (PCL) 3-23
 - friction torque compensation function 11-28
 - fully-closed control 6-16
 - supported external encoders 6-18
 - fully-closed mode adjustment 11-16
- ## G
-
- gain adjustment 11-5
 - gain settings
 - Gain Switching Delay Time in Position Control
(3116 hex) 9-13
 - Gain Switching Delay Time in Speed Control
(3121 hex) 9-16
 - Gain Switching Delay Time in Torque Control
(3125 hex) 9-18
 - Gain Switching Hysteresis in Position Control
(3118 hex) 9-13
 - Gain Switching Hysteresis in Speed Control
(3123 hex) 9-17
 - Gain Switching Hysteresis in Torque Control
(3127 hex) 9-19
 - Gain Switching Input Operating Mode Selection
(3114 hex) 9-11
 - Gain Switching Level in Position Control
(3117 hex) 9-13
 - Gain Switching Level in Speed Control (3122 hex) 9-16
 - Gain Switching Level in Torque Control
(3126 hex) 9-18
 - Position Gain Switching Time (3119 hex) 9-14
 - Position Loop Gain 1 (3100 hex) 9-7
 - Position Loop Gain 2 (3105 hex) 9-9
 - Speed Feedback Filter Time Constant 1 (3103 hex) 9-9
 - Speed Feedback Filter Time Constant 2 (3108 hex) 9-9
 - Speed Feed-forward Command Filter (3111 hex) .. 9-10
 - Speed Feed-forward Gain (3110 hex) 9-10
 - Speed Loop Gain 1 (3101 hex) 9-8
 - Speed Loop Gain 2 (3106 hex) 9-9
 - Speed Loop Integral Time Constant 1 (3102 hex) ... 9-8
 - Speed Loop Integral Time Constant 2 (3107 hex) ... 9-9
 - Switching Mode in Position Control (3115 hex) 9-11
 - Switching Mode in Speed Control (3120 hex) 9-15
 - Switching Mode in Torque Control (3124 hex) 9-17
 - Torque Command Filter Time Constant 1
(3104 hex) 9-9
 - Torque Command Filter Time Constant 2
(3109 hex) 9-10

Torque Feed-forward Command Filter (3113 hex)	9-10
Torque Feed-forward Gain (3112 hex)	9-10
gain switching 3 function	7-38
gain switching function	7-28
general-purpose inputs	3-21
General-purpose Outputs (OUTM1 and OUTM2)	3-25

H

harmonic current measures	4-53
Homing mode	6-15
hybrid vibration suppression function	11-30

I

immediate stop operation at errors	12-12
improving control I/O signal noise resistance	4-53
incremental encoder	
specifications	3-59
instantaneous speed observer function	11-34
interface monitor settings	
Analog Monitor 1 Scale Setting (3417 hex)	9-33
Analog Monitor 1 Selection (3416 hex)	9-33
Analog Monitor 2 Scale Setting (3419 hex)	9-34
Analog Monitor 2 Selection (3418 hex)	9-34
Analog Monitor Output Selection (3421 hex)	9-34
Brake Threshold Speed During Operation (3439 hex)	9-39
Brake Timing During Operation (3438 hex)	9-39
Brake Timing when Stopped (3437 hex)	9-38
Input Signal Selection 1 (3400 hex)	9-31
Input Signal Selection 2 (3401 hex)	9-31
Input Signal Selection 3 (3402 hex)	9-31
Input Signal Selection 4 (3403 hex)	9-31
Input Signal Selection 5 (3404 hex)	9-31
Input Signal Selection 6 (3405 hex)	9-32
Input Signal Selection 7 (3406 hex)	9-32
Input Signal Selection 8 (3407 hex)	9-32
Output Signal Selection 1 (3410 hex)	9-32
Output Signal Selection 2 (3411 hex)	9-32
Positioning Completion Condition Selection (3432 hex)	9-35
Positioning Completion Hold Time (3433 hex)	9-36
Positioning Completion Range 2 (3442 hex)	9-40
Rotation Speed for Motor Rotation Detection (3436 hex)	9-37
Speed Conformity Detection Range (3435 hex)	9-37
Warning Output Selection 1 (3440 hex)	9-40
Warning Output Selection 2 (3441 hex)	9-40
Zero Speed Detection (3434 hex)	9-36

L

leakage breaker	4-45
LED Display Selection	9-54

M

Main circuit connector specifications	
---------------------------------------	--

(CNA)	3-8, 3-9, 3-13, 4-21, 4-22, 4-26
Main circuit terminal block specifications	3-10, 3-14
maintenance	12-36
manual tuning	11-15
manufacturer specific objects	A-49
Absolute Encoder Setup (4102 hex)	A-54
Communications Error Setting (2200 hex)	A-50
Config (4100 hex)	A-54
Coordinate System Setting Mode (4103 hex)	A-54
Coordinate System Setting Position (4104 hex)	A-54
Error History Clear (2100 hex)	A-50
Statusword 1 (4000 hex)	A-51
Sub Error Code (4001 hex)	A-53
Sync Not Received Timeout Setting (2201 hex)	A-50
monitor inputs (MON0, MON1, and MON2)	3-23
monitor output circuit	3-31
monitor output signal table	3-31
Motor connector specifications	
(CNB)	3-8, 3-9, 3-13, 4-21, 4-22, 4-26
motor power cable specifications	3-75
motor power cables (Robot Cable)	2-24
motor power cables (Standard Cable)	2-21
Motor Rotation Speed Detection Output (TGON)	3-25
mounting brackets (L-brackets for rack mounting)	2-27
dimensions	2-91
Multiple PDO Mapping	5-10

N

node address setting	5-2
no-fuse breaker (NFB)	4-44
noise filter for power supply input	4-39
noise filter for the brake power supply	4-47
noise filters	4-47, 4-48, 4-54
noise filters for motor output	4-54
notch filter	11-23
width and depth	11-24, 11-25

O

object description format	A-23
object dictionary	1-3
area	A-22
data types	A-22
object list	A-77
operational procedure	10-2
Origin Proximity Input (DEC)	3-22
overload characteristics (electronic thermal function)	3-35
overrun protection	7-11

P

PDO mapping	5-6
PDO mapping for position control	5-8, 5-9
PDO mapping objects	A-31
1st receive PDO Mapping (1600 hex)	A-31
1st transmit PDO Mapping (1A00 hex)	A-38
258th receive PDO Mapping (1701 hex)	A-33
258th transmit PDO Mapping (1B01 hex)	A-40

259th receive PDO Mapping (1702 hex)	A-34
259th transmit PDO Mapping (1B02 hex)	A-41
260th receive PDO Mapping (1703 hex)	A-35
260th transmit PDO Mapping (1B03 hex)	A-42
261th receive PDO Mapping (1704 hex)	A-36
261th transmit PDO Mapping (1B04 hex)	A-43
262th receive PDO Mapping (1705 hex)	A-37
512th transmit PDO Mapping (1BFF hex)	A-44
PDO Mapping Settings	5-6
periodic maintenance	12-36
peripheral equipment connection examples	4-11
position control mode adjustment	11-16
Positioning Completion Output 2 (INP2)	3-25
Power Cable Connector	3-93
Power Cables with Brakes (Robot Cable)	3-85
Power Cables with Brakes (Standard Cable)	3-82
power cables without brakes (Robot Cable)	3-79
power cables without brakes (Standard Cable)	3-75
preparing for operation	10-3
process data objects (PDOs)	5-6
Profile Position Mode	6-11
R	
radio noise filter	4-48
Reactor	
Dimensions	2-87
model list	2-27
Reactor Specifications	3-106
reactor to reduce harmonic current	4-53
reactors	4-53
realtime autotuning	11-7
Reduction Gear	
15 Arcminutes Max.	2-7
For 3,000-r/min Servomotors	3-66
3 Arcminutes Max.	2-6, 2-16
For 1,000-r/min Servomotors	2-19, 3-65
For 2,000-r/min Servomotors	2-18, 3-63
For 3,000-r/min Servomotors	2-16, 3-60
Reference Position for CSP	A-53
regeneration absorption capacity	4-58
regenerative energy absorption	4-56
Remote Outputs (R-OUT1 and R-OUT2)	3-27
reverse drive prohibition function	7-8
Reverse Drive Prohibition Input (NOT)	3-22
Reverse External Torque Limit Input (NCL)	3-23
rotation speed characteristics	
1,000-r/min Servomotors	3-57
1,500-r/min, 2,000-r/min Servomotors	3-52
3,000-r/min Servomotors	3-43
S	
safe torque OFF function	8-2
safety connector specifications (CN8)	3-33
Safety I/O Signal Connector	3-98
safety I/O signal table	3-33
safety I/O signals	3-33
safety input circuit	3-34
safety input signals	8-3
Saving the Node Address Setting	5-15
SEMI F47	1-17
sequence I/O signal	
input signals	7-2
output signals	7-5
sequence outputs	3-23
Serial Number Display	5-16
service data objects (SDOs)	5-12
Servo Drive	
characteristics	
100-VAC input models	3-3
200-VAC input models	3-4
400-VAC input models	3-6
dimensions	2-28
general specifications	3-2
installation conditions	4-2
life expectancy	12-37
model number	2-4
model table	2-8
replacing	12-4
Servo Drive and Servomotor combination tables	2-14
Servo Drive profile objects	A-55
Controlword (6040 hex)	A-56
Digital inputs (60FD hex)	A-72
Digital outputs (60FE hex)	A-74
Disable operation option code (605C hex)	A-59
Error code (603F hex)	A-55
Fault reaction option code (605E hex)	A-60
Following error actual value (60F4 hex)	A-72
Following error window (6065 hex)	A-62
Gear ratio (6091 hex)	A-66
Halt option code (605D hex)	A-59
Home offset (607C hex)	A-63
Homing method (6098hex)	A-67
Homing speeds (6099 hex)	A-67
Max profile velocity (607F hex)	A-64
Max torque (6072 hex)	A-63
Modes of operation (6060 hex)	A-61
Modes of operation display (6061 hex)	A-61
Motion profile type (6086 hex)	A-65
Motor type (6402 hex)	A-75
Negative torque limit value (60E1 hex)	A-71
Position actual internal value (6063 hex)	A-62
Position actual value (6064 hex)	A-62
Position demand internal value (60FC hex)	A-72
Position demand value (6062 hex)	A-61
Position offset (60B0 hex)	A-68
Position window (6067 hex)	A-62
Positive torque limit value (60E0 hex)	A-70
Profile acceleration (6083 hex)	A-65
Profile deceleration (6084 hex)	A-65
Profile velocity (6081 hex)	A-64
Shutdown option code (605B hex)	A-58
Software position limit (607D hex)	A-64
Statusword (6041 hex)	A-56
Supported drive modes (6502 hex)	A-76
Supported homing method(60E3 hex)	A-71
Target position (607A hex)	A-63

- Target torque (6071 hex) A-63
 - Target velocity (60FF hex) A-75
 - Torque actual value (6077 hex) A-63
 - Torque demand (6074 hex) A-63
 - Torque offset (60B2 hex) A-68
 - Touch probe function (60B8 hex) A-69
 - Touch probe pos1 pos value (60BA hex) A-70
 - Touch probe pos2 pos value (60BC hex) A-70
 - Touch probe status (60B9 hex) A-70
 - Velocity actual value (606C hex) A-62
 - Velocity offset (60B1 hex) A-68
 - Servo Ready Completed Output (READY) 3-25
 - Servomotor
 - characteristics
 - 1,000-r/min Servomotors 3-55
 - 1,500-r/min, 2,000-r/min Servomotors 3-47
 - 3,000-r/min Servomotors 3-37
 - dimensions
 - 1,000-r/min Servomotors 2-62
 - 1,500-r/min, 2,000-r/min Servomotors 2-53
 - 3,000-r/min Servomotors 2-44
 - general specifications 3-36
 - installation conditions 4-3
 - life expectancy 12-36
 - model number 2-5
 - model tables 2-9
 - replacing 12-3
 - Servo Drive and Servomotor combination tables .. 2-14
 - SII Data Check 5-17
 - Soft Start 7-26
 - special objects
 - Backlash Compensation Amount (3705 hex) 9-55
 - Backlash Compensation Selection (3704 hex) 9-55
 - Backlash Compensation Time Constant (3706 hex) 9-55
 - Communications Control (3800 hex) 9-57
 - Disturbance Observer Filter Setting (3624 hex) 9-50
 - Disturbance Torque Compensation Gain (3623 hex) 9-50
 - Electric Current Response Setting (3611 hex) 9-49
 - Error Detection Allowable Time Setting (3614 hex) 9-49
 - Excessive Speed Error Setting (3602 hex) 9-47
 - Forward Direction Torque Offset (3608 hex) 9-47
 - Function Expansion Setting (3610 hex) 9-48
 - Gain 3 Effective Time (3605 hex) 9-47
 - Gain 3 Ratio Setting (3606 hex) 9-47
 - Hybrid Vibration Suppression Filter (3635 hex) 9-52
 - Hybrid Vibration Suppression Gain (3634 hex) 9-52
 - Origin Range (3803 hex) 9-59
 - Overspeed Detection Level Setting at Immediate Stop (3615 hex) 9-49
 - Position Command FIR Filter Time Constant (3818 hex) 9-59
 - Power ON Address Display Duration Setting (3701 hex) 9-55
 - Power Supply ON Initialization Time (3618 hex) ... 9-49
 - Realtime Autotuning Estimated Speed Selection (3631 hex) 9-50
 - Reserved (3822 hex) 9-60
 - Reverse Direction Torque Offset (3609 hex) 9-47
 - Torque Command Value Offset (3607 hex) 9-47
 - Torque Limit Flag Output Setting (3703 hex) 9-55
 - Vibration Detection Threshold (3637 hex) 9-52
 - Warning Hold Selection (3759 hex) 9-56
 - Warning Mask Setting (3638 hex) 9-53
 - Speed Conformity Output (VCMP) 3-26
 - status indicators 5-3
 - surge absorber 4-46
 - surge suppressor 4-51
 - Sync Manager 5-7
 - Sync Manager Communication Objects A-44
 - Sync Manager 0 PDO Assignment (1C10 hex) A-45
 - Sync Manager 1 PDO Assignment (1C11 hex) A-45
 - Sync Manager 2 PDO Assignment (1C12 hex) A-45
 - Sync Manager 3 PDO Assignment (1C13 hex) A-46
 - Sync Manager Communication Type (1C00 hex) .. A-44
 - Sync Manager2 synchronization (1C32 hex) A-47
 - Sync Manager3 synchronization (1C33 hex) A-48
 - Sync Not Received Timeout Setting (2201 hex) A-50
 - Sysmac Device 1-2
 - Sysmac Error A-49
 - Sysmac Error Status 5-15
 - Sysmac Products Features 5-15
 - system block diagram 1-7
 - system configuration 1-4, 2-2
- ## T
-
- terminal block
 - wiring procedure 4-33
 - Terminal block specifications ..3-10, 3-11, 3-12, 3-15, 3-16, 4-23, 4-24, 4-25, 4-27, 4-28, 4-29
 - terminal block wire sizes 4-30
 - Torque Limit Output (TLIMIT) 3-26
 - torque limit switching 7-24
 - Touch probe function 7-40
 - trial operation 10-8
 - troubleshooting 12-2, 12-14
 - troubleshooting using the operation state 12-30
 - troubleshooting with error displays 12-14
- ## U
-
- UL and cUL standards 1-16
 - USB connector specifications (CN7) 3-32
- ## V
-
- vibration suppression settings
 - Adaptive Filter Selection (3200 hex) 9-20
 - Damping Filter 1 Setting (3215 hex) 9-23
 - Damping Filter 2 Setting (3217 hex) 9-24
 - Damping Filter 3 Setting (3219 hex) 9-24
 - Damping Filter 4 Setting (3221 hex) 9-24
 - Damping Filter Selection (3213 hex) 9-23
 - Damping Frequency 1 (3214 hex) 9-23
 - Damping Frequency 2 (3216 hex) 9-23
 - Damping Frequency 3 (3218 hex) 9-24

Damping Frequency 4 (3220 hex) 9-24
Notch 1 Depth Setting (3203 hex) 9-20
Notch 1 Frequency Setting (3201 hex) 9-20
Notch 1 Width Setting (3202 hex) 9-20
Notch 2 Depth Setting (3206 hex) 9-21
Notch 2 Frequency Setting (3204 hex) 9-21
Notch 2 Width Setting (3205 hex) 9-21
Notch 3 Depth Setting (3209 hex) 9-22
Notch 3 Frequency Setting (3207 hex) 9-21
Notch 3 Width Setting (3208 hex) 9-21
Notch 4 Depth Setting (3212 hex) 9-22
Notch 4 Frequency Setting (3210 hex) 9-22
Notch 4 Width Setting (3211 hex) 9-22
Position Command Filter Time Constant
(3222 hex) 9-25

W

warning list 12-6
Warning Outputs (WARN1 and WARN2) 3-27
wiring conforming to EMC Directives 4-35

Z

Zero Speed Detection Output (ZSP) 3-26

OMRON Corporation Industrial Automation Company

Tokyo, JAPAN

Contact: www.ia.omron.com

Regional Headquarters

OMRON EUROPE B.V.

Wegalaan 67-69, 2132 JD Hoofddorp
The Netherlands

Tel: (31)2356-81-300/Fax: (31)2356-81-388

OMRON ELECTRONICS LLC

2895 Greenspoint Parkway, Suite 200
Hoffman Estates, IL 60169 U.S.A

Tel: (1) 847-843-7900/Fax: (1) 847-843-7787

OMRON ASIA PACIFIC PTE. LTD.

No. 438A Alexandra Road # 05-05/08 (Lobby 2),
Alexandra Technopark,
Singapore 119967

Tel: (65) 6835-3011/Fax: (65) 6835-2711

OMRON (CHINA) CO., LTD.

Room 2211, Bank of China Tower,
200 Yin Cheng Zhong Road,
PuDong New Area, Shanghai, 200120, China

Tel: (86) 21-5037-2222/Fax: (86) 21-5037-2200

Authorized Distributor:

© OMRON Corporation 2011 All Rights Reserved.
In the interest of product improvement,
specifications are subject to change without notice.

Cat. No. I576-E1-03

0315