

SGMZH-□

Rotary ATEX servo motors

ATEX compliant AC servomotor for Sigma II Servo Drive

Our new flameproof servomotor is both compact and lightweight

- This product complies with the ATEX Directive 94/9/EC, and is approved for use in EU countries
- ATEX Flameproof compliant **II 2 GD Ex d II B T4**
- Built-in high resolution, absolute encoder
- Compact design and robust construction
- 4 different Built-in cable length available

Ratings

- 400 VAC from 500 W to 3 kW (rated torque from 1.59 Nm to 14.3 Nm)
- 2000 rpm and 3000 rpm



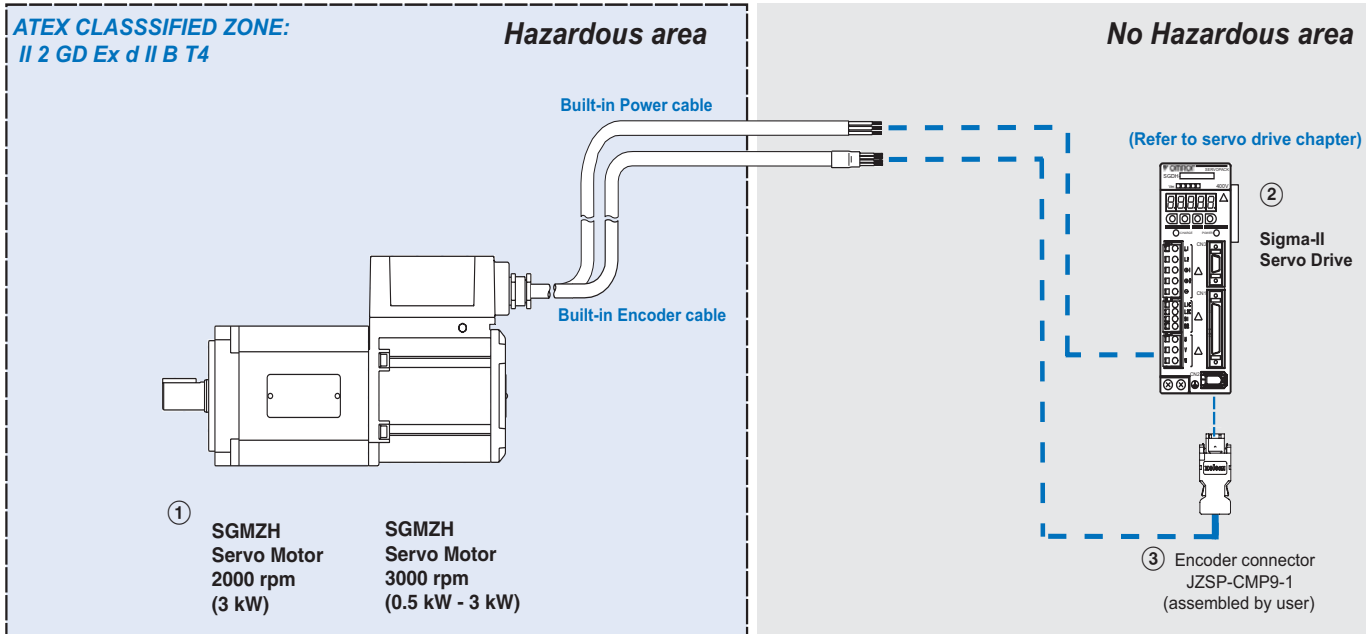

AC Servo systems

System configuration



Servo motor / Servo drive combination

Sigma-II Rotary ATEX Servo motor					Sigma-II servo drive
	Voltage	Rated torque	Capacity	Model	400 V (3-phase)
SGMZH (3000 min ⁻¹) 	400 V	1.59 N.m	0.5 kW	SGMZH-05D2A□	SGDH-05DE-OY
		3.18 N.m	1.0 kW	SGMZH-10D2A□	SGDH-10DE-OY
		5.73 N.m	1.8 kW	SGMZH-18D2A□	SGDH-20DE-OY
		9.8 N.m	3.0 kW	SGMZH-30D2A□	SGDH-30DE-OY
SGMZH (2000 min ⁻¹) 		14.3 N.m	3.0 kW	SGMZH-30D2B□	SGDH-50DE-OY

Note: 1. For servo motor part numbers refer to ordering information at the end of this chapter
 2. Refer to the servo drive chapter for drive options selection and detailed specifications

Motor Type designation

Servo motor

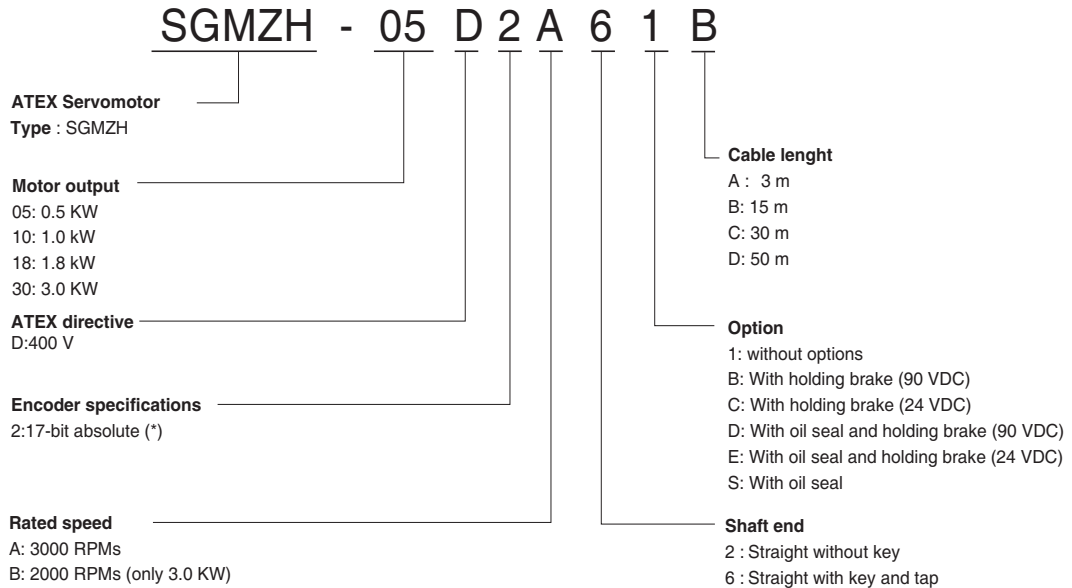

* This servomotor is not applicable for an incremental encoder.

Servo motor specifications

Type SGMZH, 400 V

Ratings and specifications

Applied voltage		400V				
Servo motor model SGMZH-□		05D2A□	10D2A□	18D2A□	30D2A□	30D2BA□
Rated output ^{*1}	KW	.5	1.0	1.8	3.0	3.0
Rated torque ^{*1, *2}	N·m	1.59	3.18	5.73	9.8	14.3
Instantaneous peak torque ^{*1}	N·m	4.77	9.54	17.2	29.4	42.9
Rated current ^{*1}	A (rms)	1.6	2.9	5.2	9.0	12.6
Instantaneous max. current ^{*1}	A (rms)	4	8.5	18	28	39
Rated speed ^{*1}	min ⁻¹	3000				
Max. speed ^{*1}	min ⁻¹	5000				
Torque constant	N·m/A (rms)	1.27	1.27	1.18	1.16	1.21
Rotor moment of inertia (JM)	kg·m ² ×10 ⁻⁴	1.74	1.74	2.47	7.00	12.3
Rated power rate ^{*1}	kW/s	14.5	58.1	133	137	166
Rated angular acceleration ^{*1}	rad/s ²	9138	18276	23198	14000	11626
Applicable encoder	Standard	Absolute encoder (17bits)				
Basic specifications	Time Rating	Continuous				
	Thermal Class	F				
	Vibration Class	V15				
	Withstand Voltage	1800 VAC for one minute				
	Insulation Resistance	500 VDC, 10 M ohm min.				
	Degree of Protection	Totally enclosed, self-cooled, IP64 (except for shaft opening)				
	Ambient Humidity	20% to 80% (no condensation)				
	Drive Method	Direct drive				
	Rotation Direction	Counterclockwise (CCW)				
	Color	Munsell N1.5				
	Ambient Temperature	0°C to 40°C				
	Excitation	Permanent magnet				
Mounting	Flange method					

- Note:** 1. *1. These items and speed/torque characteristics quoted in combination with an SGDh servo drive are at an armature winding temperature of 20 °C.
 2. *2. Rated torques are continuous allowable torque values at an ambient temperature of 40°C with an aluminium heatsink attached: SGMZH-05, 10, 18 : 300 mm x 300 mm x 12 mm ; SGMZH-30D2A, 30D2B : 400 mm x 400 mm x 20 mm.

ATEX Flameproof Compliance

Certification of Notified Body:

TüV SÜD Product Service notified Body No 0123 in accordance with Article 9 of the Council Directive 94/9/EC of March 23rd 1994, certifies that this equipment has been found to comply with the Essential Health and Safety Requirements relating to the design and construction of equipment and protective systems intended for use in potentially explosive atmospheres, given in Annex II of the Directive

The AC Servo motor is certified for temperature class T4 (i.e. max. surface temperature range between 100 °C and 135 °C.

This product can be used in the following subdivisions gases and temperature classes:

- Subdivision gases : IIB, IIA
- Temperature classes: T4, T3, T2 and T1

Refer to EN50014 for specific regulations regarding gas concentration and gas content in the surrounding air.

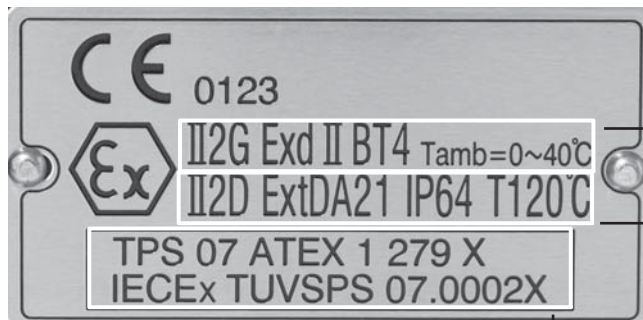

GAS
 CATEGORY: 2 ZONE 1,2
 TYPE OF PROTECTION: FLAMEPROOF ENCLOSURE "d"
 SUBDIVISION GASES : IIB
 TEMPERATURE CLASS: T4 (135 °C)

DUST
 CATEGORY: 2 ZONE 21, 22
 DEGREE OF PROTECTION: IP64
 MAXIMUM SURFACE TEMPERATURE: 120°C

Standard Compliance
 Zone Classification : EN60079-10
 Equipment Category : 94/9/EC
 Gas Subdivision : EN50014

ATEX DIRECTIVE 94/9/EC CERTIFICATION NUMBER:
 TPS 07 ATEX 1 279 X
IECEX SCHEME CERTIFICATION NUMBER:
 IECEX TUVSPS 07.0002 X

Torque-speed characteristics

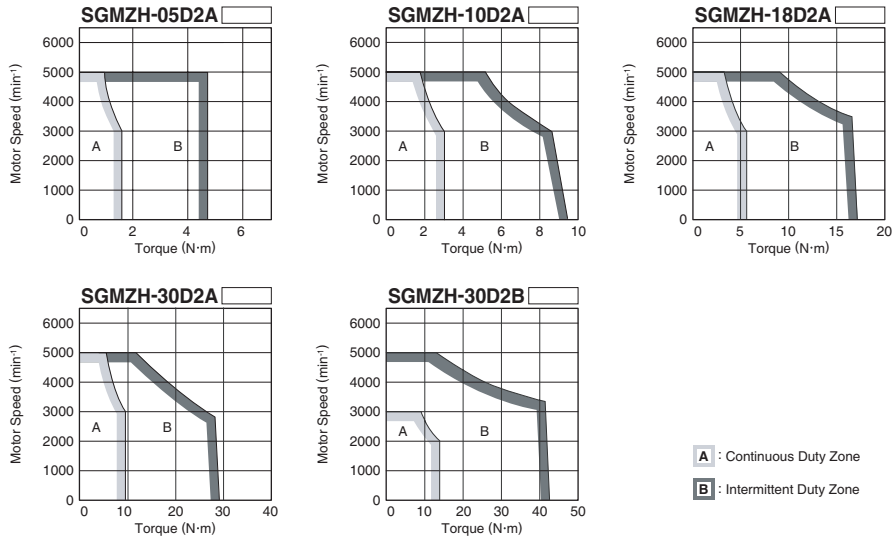

Dimensions

Servo motor

Type SGMZH (400 V)

Dimensions (mm)	L	LL	LR	KL1	KL2	Flange face						Shaft end					Tap x Depth	Aprx. Mass (Kg)	Aprx. Mass (Kg) with holding brake									
						LA	LB	LC	LE	LG	LH	LZ	S	Q	QK	T				U	W							
Model																												
SGMZH-05D2A□	295	255	40	120	90	135		120	6	15	155	9		30	25	5	3	5	M5x2	10	11							
SGMZH-10D2A□															40	32	7	4	8	M8x16	11	12.5						
SGMZH-18D2A□	331	281	50	120						16	195	11		50	40						19.5	21.2						
SGMZH-30D2A□	386	326	60	138	104	165		150						60	50						26.5	28.2						
SGMZH-30D2B□	475	405	70																									

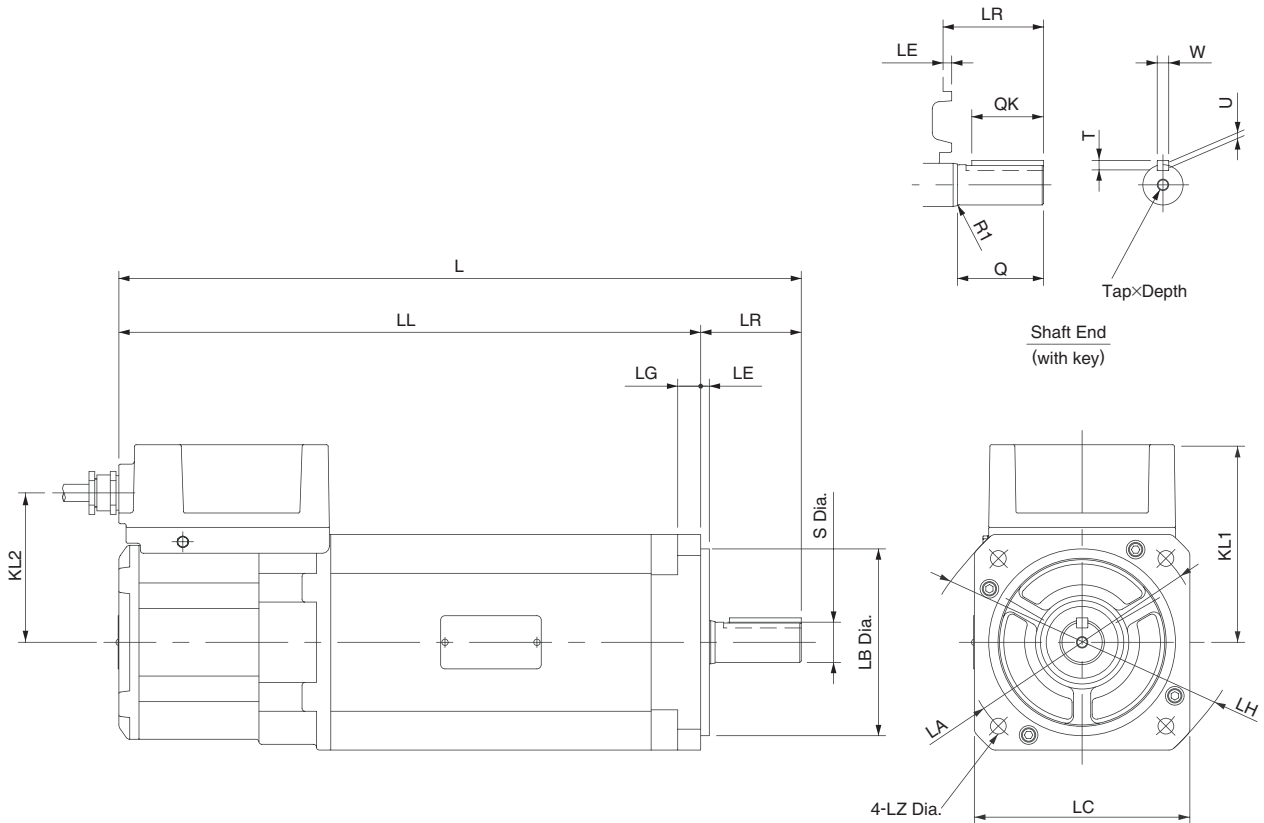

Built-in Motor Cable

Signal	Wire Color	Size
U	Red	SGMZH-05, 10, 18: AWG17 SGMZH-30D2A, 30D2B: AWG12
V	White	
W	Black	
FG (frame ground)	Green	AWG19
Brake (with brake option only)	Yellow	
Brake (with brake option only)	Blue	

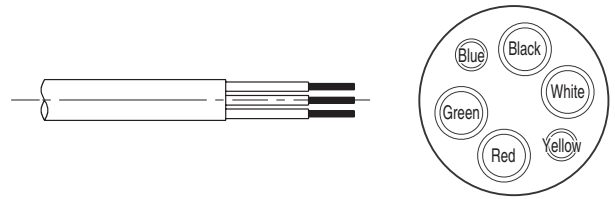

Built-in Encoder Cable

Signal	Wire Color	Size
DATA+	Red	AWG26
DATA-	Blue	
+5VDC	Red	AWG16
0 V	Black	
FG (frame ground)	White (shield)	AWG26
BATT+	Yellow	
BATT-	White	

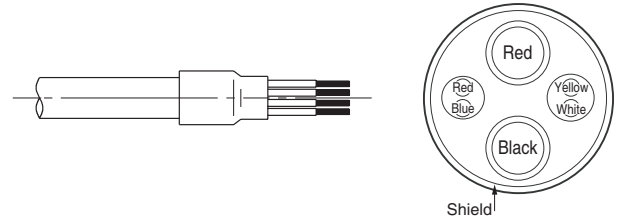

Ordering information

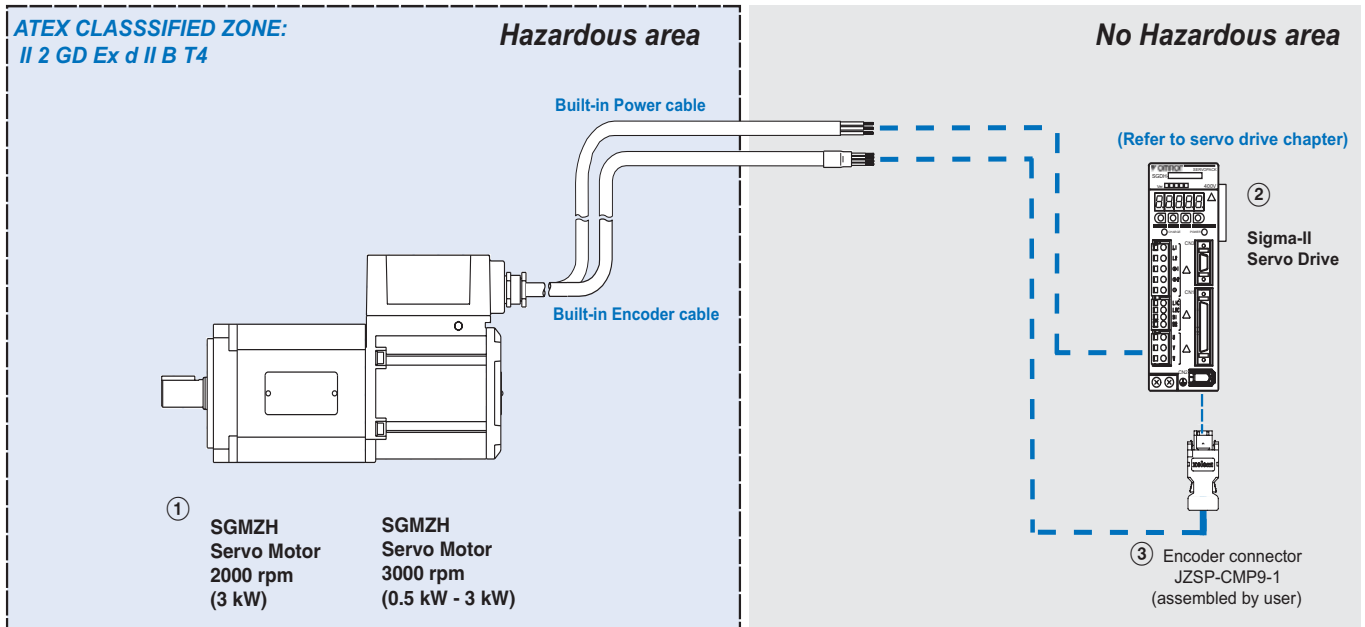

Note: The symbols ①②③... show the recommended sequence to select the servo motor and cables.

Note: For connections to Servodrive in no hazardous area follow wire color and cable size indications provided above.

The protection level of this ATEX compliant flameproof AC Servo motor is category 2; the following conditions are recommended for the installation location:

- Well-ventilated, allowing dispersion of flammable gases or vapors.
- Sufficient space for maintenance.
- Not subject to dust
- Ready access to fire prevention equipment.

Servo motor



① Select motor from families SGMZH 3000r/min or SGMZH 2000 r/min using motor tables below.

Servo drive

② Refer to Sigma-II servo drive chapter for detailed drive specifications and selection of drive accessories.

③ Order Encoder Connector (assembled by user)

ATEX servo motors (0.5 kW - 3 kW)

Symbol	Specifications					Servo motor model	Compatible servo drives (2) Sigma-II				
	Voltage	Encoder and design		Rated torque	Capacity			Built-in Cable length			
① 3000 rpm 	400 V	Absolute encoder (17 bit) Straight shaft with key & tap	Without brake	1.59 Nm	0.5 kW	3 m	SGMZH-05D2A61A	SGDH-05DE-OY			
						15 m	SGMZH-05D2A61B				
						30 m	SGMZH-05D2A61C				
						50 m	SGMZH-05D2A61D				
				3.18 Nm	1.0 kW	3 m	SGMZH-10D2A61A		SGDH-10DE-OY		
						15 m	SGMZH-10D2A61B				
						30 m	SGMZH-10D2A61C				
						50 m	SGMZH-10D2A61D				
				5.73 Nm	1.8 kW	3 m	SGMZH-18D2A61A		SGDH-20DE-OY		
						15 m	SGMZH-18D2A61B				
			30 m			SGMZH-18D2A61C					
			50 m			SGMZH-18D2A61D					
			9.8 Nm	3.0 kW	3 m	SGMZH-30D2A61A	SGDH-30DE-OY				
					15 m	SGMZH-30D2A61B					
					30 m	SGMZH-30D2A61C					
					50 m	SGMZH-30D2A61D					
			With 24 VDC brake	400 V	Absolute encoder (17 bit) Straight shaft with key & tap	Without brake	1.59 Nm	0.5 kW	3 m	SGMZH-05D2A6CA	SGDH-05DE-OY
									15 m	SGMZH-05D2A6CB	
									30 m	SGMZH-05D2A6CC	
									50 m	SGMZH-05D2A6CD	
3.18 Nm	1.0 kW	3 m				SGMZH-10D2A6CA	SGDH-10DE-OY				
		15 m				SGMZH-10D2A6CB					
		30 m				SGMZH-10D2A6CC					
		50 m				SGMZH-10D2A6CD					
5.73 Nm	1.8 kW	3 m				SGMZH-18D2A6CA	SGDH-20DE-OY				
		15 m				SGMZH-18D2A6CB					
		30 m	SGMZH-18D2A6CC								
		50 m	SGMZH-18D2A6CD								
9.8 Nm	3.0 kW	3 m	SGMZH-30D2A6CA	SGDH-30DE-OY							
		15 m	SGMZH-30D2A6CB								
		30 m	SGMZH-30D2A6CC								
		50 m	SGMZH-30D2A6CD								
① 2000 rpm 	400 V	Absolute encoder (17 bit) Straight shaft with key & tap	Without brake	14.3 Nm	3.0 kW	3 m	SGMZH-30D2B61A	SGDH-50DE-OY			
						15 m	SGMZH-30D2B61B				
						30 m	SGMZH-30D2B61C				
						50 m	SGMZH-30D2B61D				
			With 24 VDC brake	14.3 Nm	3.0 kW	3 m	SGMZH-30D2B6CA		SGDH-50DE-OY		
						15 m	SGMZH-30D2B6CB				
						30 m	SGMZH-30D2B6CC				
						50 m	SGMZH-30D2B6CD				

Connector for Encoder cable

Symbol	Specifications	Model	Appearance
③	Encoder connector Sigma II (for CN2)	JZSP-CMP9-1	

ALL DIMENSIONS SHOWN ARE IN MILLIMETERS.
 To convert millimeters into inches, multiply by 0.03937. To convert grams into ounces, multiply by 0.03527.