

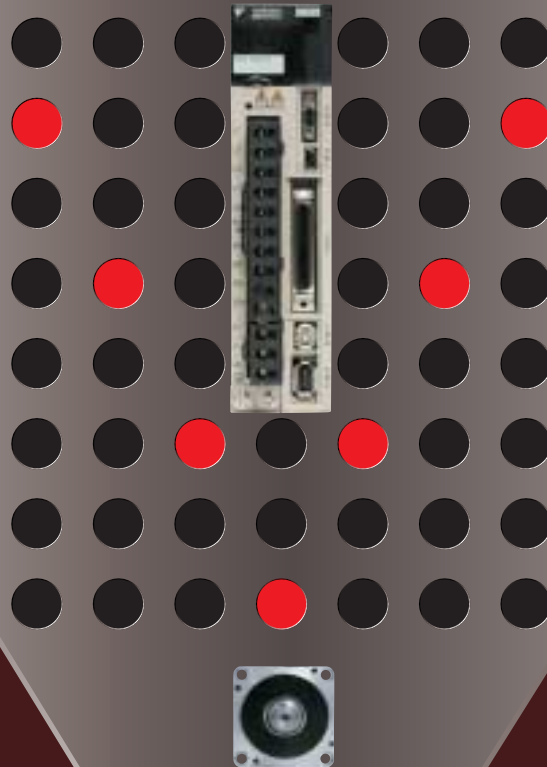

YASKAWA

AC SERVO DRIVES Σ -V SERIES PRODUCT CATALOG

Field-Proven Performance:
A Servo that Does What You Need!



Certified for
ISO9001 and
ISO14001



JQA-0422

JQA-EM0202

JQA-EM0924

Build the machine you've dreamed of, today!

AC servo drive
Sigma Five

Σ -V

You want maximum effect quickly and easily, as does every engineer in the field. And now the Σ -V series is here with the practical answer to your dreams!

How many times have you heard people say servos need adjustment to work well? Our new tuning-less function means it works as soon as you hook it up!

And if you want more performance than ever before, the Σ -V series advanced autotuning function lets you accomplish it rapidly.

Advanced technology makes possible a host of safety standards compliance for the first time in Japan (as of April 2007), compliance with key international standards, a diverse motor line-up, compact size, high speed and simple maintenance: everything you need to answer today's requirements.



International Standards



Safety Standards

Safety Stop-0 (Standard)

RoHS Directive

RoHS Directive Stands for the EU directive on the Restriction of the Use of Certain Hazardous Substances in Electrical and Electronic Equipment.

Features

Superlative Performance

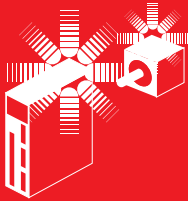

Operate your machinery faster and with higher precision than ever!

The Σ -V delivers the highest performance in the industry.

- The best amplifier response in the industry slashes settling time

In-house comparison: 1/12th

Outstanding frequency response

1.6 kHz



● Servo Adjustment Example

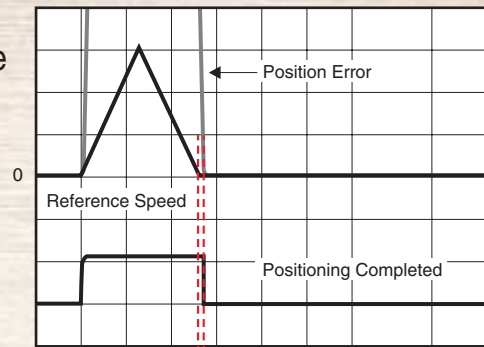

Settling Time 0 to 4 ms! (Σ -V)

- Enhanced vibration suppression

Existing functions to minimize vibration have been enhanced, and new ones added, improving tracking and further improving settling time. Vibration and noise during driving have also been cut, along with vibration at machine edges when stopping.

- Contributing to machine performance in conjunction with a medium-inertia motor

Small Capacity

SGMJV Series



Low Heating

Improved motor constants have reduced both losses and heating.

Better Tact Time

Peak torque has been boosted from 300% to 350%, contributing to shorter tact times

Ease of Use

Moment of inertia has been doubled in the same motor, reducing the load inertia ratio and boosting gain for faster settling

Medium Capacity

SGMGV Series



Compact Design

Smaller package and about 20% lighter, but with the same inertia as the conventional model. A small encoder connector is applied.

Improved Vibration Resistance

New coupling delivers typical 5G vibration resistance

Resolution 1,048,576 pulses/revolution

Simple Start-up

Making servo adjustment quick and simple

Let the Σ -V series simplify your life!

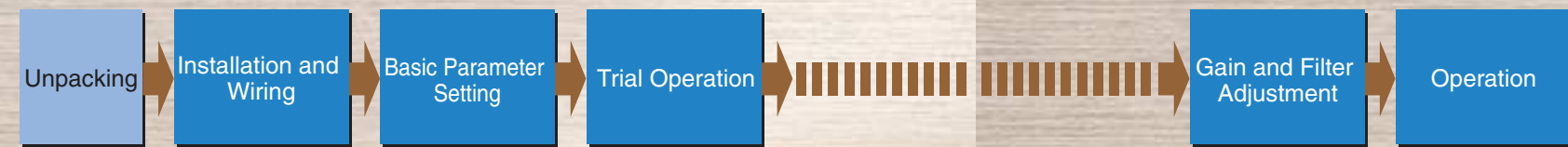

Faster setup

SigmaWin+

Setup Wizard
Simple parameter set-up with wizard-aided input

Wiring Check Function
The SigmaWin+ wiring check function checks your wiring in a single operation

Trace Function
Realtime trace of adjustment state means you can check instantly.

USB1.1 Support

Simple Tuning

New Advanced Autotuning Window

Get up and running quickly after hooking up the motor
New Tuning-less Function
Even without servo adjustment and with load changes, oscillation- and vibration-free drive is possible up to 20 times the load moment of inertia.
Settling time: 100 to 150 ms level

Minimize settling time with less vibration
New Advanced Autotuning
The reference filter and feedback gain adjustment functions have a new automatic feed forward gain adjustment for optimal adjustment performance. The friction compensation function automatically cancels out the effect of friction on machine characteristics.
Settling time: 10 ms level

Fine-tuning is a must
New "One-parameter" Tuning
Fine-tuning can tweak machine performance to the max.
Settling time: 0 to 4 ms level

● Full of handy functions for start-up and more effective operation!

■ **Selection**
Servomotor capacity selection software
SigmaJunmaSize+
Optimal selection for your application:
With consideration of moment of inertia, DB resistance, etc.



■ **Maintenance**
Faster Troubleshooting
PC tool
SigmaWin+
Alarm diagnostic function:
Presumes possible causes of the alarm and immediately displays suggested corrective actions.

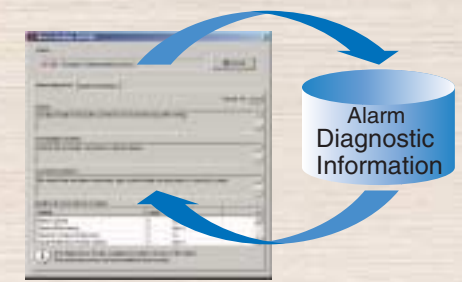

Outstanding Expandability



Use servos that really fit into your system

A rich selection of models and options to match your requirements

- Extensive variety of motors to match any machine
 Medium-inertia servomotors → Improved control stability
 Low-inertia servomotors → High-speed acceleration and deceleration
- Selection of servo actuators
 Support for direct drive servomotors, linear servomotors and linear sliders
- Standard support for analog voltage/pulse train reference series or MECHATROLINK-II communications reference series
- Wide selection of option modules for various communication interfaces and feedback
- Compliant with applicable safety standards
 Easy compliance with machine safety standards
- Motor line-up to handle a wide range of markets and applications

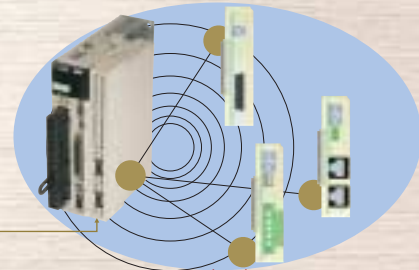

Option Module

The first in the industry in Japan!

(as of April 2007)

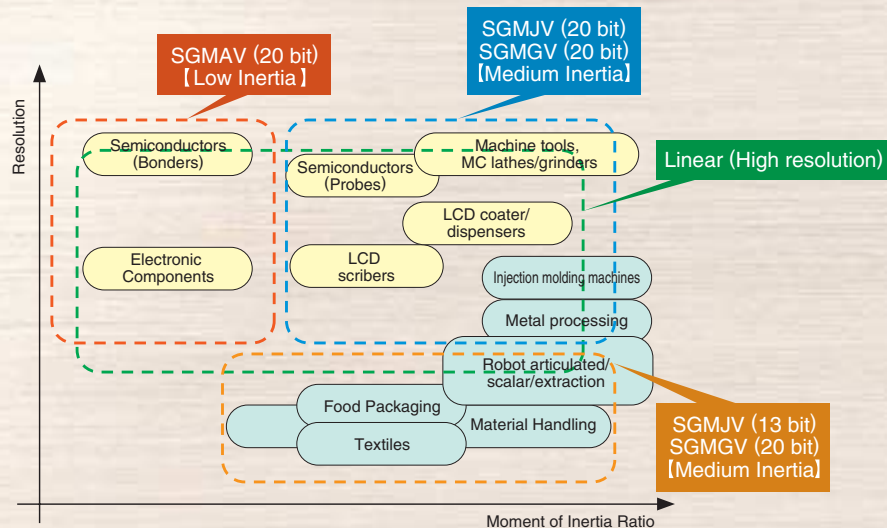

Product Line-up

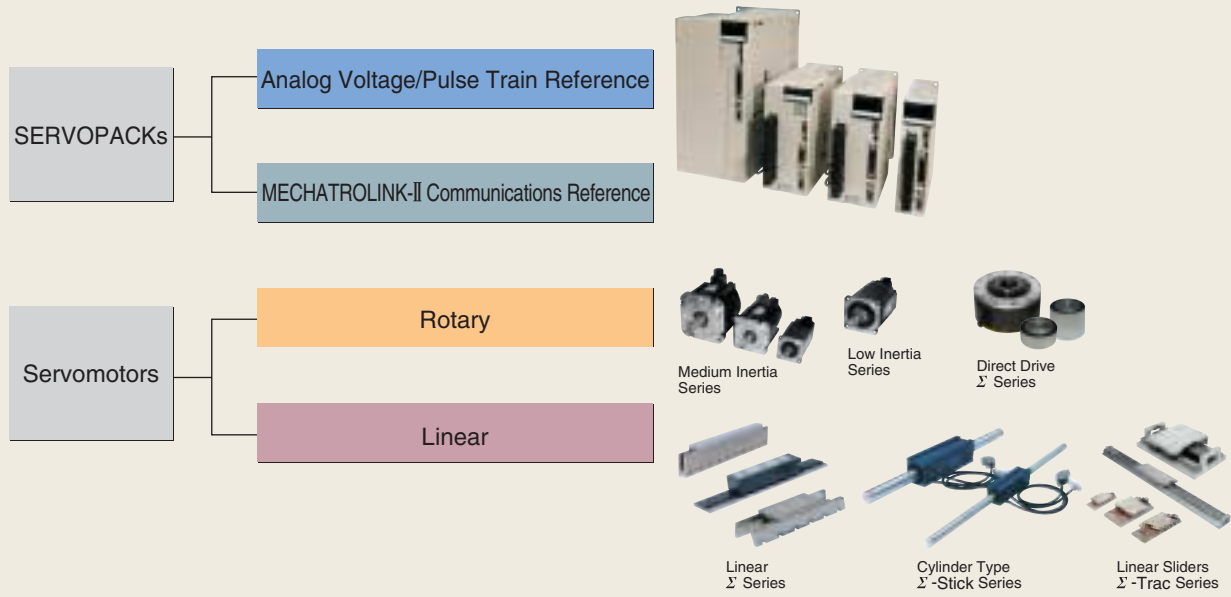

Rotary Servomotor Model			SERVOPACK Model	
			Three-phase 200 VAC	Three-phase 400 VAC
Medium Inertia, Small Capacity Servomotor	Three-phase 200 VAC	SGMJV-A5A	SGDV-R70A	—
		SGMJV-01A	SGDV-R90A	—
		SGMJV-02A	SGDV-1R6A	—
		SGMJV-04A	SGDV-2R8A	—
		SGMJV-08A	SGDV-5R5A	—
Low Inertia, Small Capacity Servomotor	Three-phase 200 VAC	SGMAV-A5A	SGDV-R70A	—
		SGMAV-01A	SGDV-R90A	—
		SGMAV-C2A	SGDV-1R6A	—
		SGMAV-02A		—
		SGMAV-04A	SGDV-2R8A	—
		SGMAV-06A	SGDV-5R5A	—
SGMAV-08A	—			
Medium Inertia, Medium Capacity Servomotor	Three-phase 400 VAC	SGMGV-03D	—	SGDV-1R9D
		SGMGV-05D	—	
		SGMGV-09D	—	SGDV-3R5D
		SGMGV-13D	—	SGDV-5R4D
		SGMGV-20D	—	SGDV-8R4D
		SGMGV-30D	—	SGDV-120D
		SGMGV-44D	—	SGDV-170D
Direct Drive Servomotor	Three-phase 200 VAC	SGMCS-02B	SGDV-2R8A	—
		SGMCS-05B		—
		SGMCS-07B		—
		SGMCS-04C		—
		SGMCS-10C		—
		SGMCS-14C		—
		SGMCS-08D		—
		SGMCS-17D		—
		SGMCS-25D	SGDV-5R5A	—
		SGMCS-16E		—
SGMCS-35E	—			



Linear Servomotor Model		SERVOPACK Model Three-phase 200 VAC	
Linear Servomotors	Coreless Type (With standard magnetic way)	SGLGW-30A050	SGDV-R70A
		SGLGW-30A080	SGDV-R90A
		SGLGW-40A140	
		SGLGW-40A253	SGDV-1R6A
		SGLGW-60A140	
		SGLGW-40A365	SGDV-2R8A
		SGLGW-60A253	
	SGLGW-60A365	SGDV-5R5A	
	Coreless Type (With high-efficiency magnetic way)	SGLGW-40A140	SGDV-1R6A
		SGLGW-60A140	
		SGLGW-40A253	SGDV-2R8A
		SGLGW-40A365	SGDV-3R8A
		SGLGW-60A253	
	With F-type Iron Core	SGLFW-20A090	SGDV-1R6A
		SGLFW-20A120	
		SGLFW-35A120	
		SGLFW-35A230	SGDV-3R8A
		SGLFW-50A200	SGDV-5R5A
	With T-type Iron Core	SGLTW-20A170	SGDV-3R8A
		SGLTW-35A170	SGDV-5R5A
		SGLTW-50A170	
	Cylinder Type	SGLCW-D16A085	SGDV-R70A
		SGLCW-D16A115	
		SGLCW-D16A145	SGDV-R90A
SGLCW-D20A100		SGDV-1R6A	
SGLCW-D20A135			
SGLCW-D20A170			
SGLCW-D25A125		SGDV-2R8A	
SGLCW-D25A170			
SGLCW-D32A165		SGDV-5R5A	
SGLCW-D25A215			
SGLCW-D32A225			
SGLCW-D32A285			
Linear Sliders	Σ -Trac	SGT-□G1□	SGDV-R90A
		SGT-□G2□	SGDV-1R6A
		SGT-□G4□	
		SGT-□F3□	
		SGT-□G3□	SGDV-2R8A
		SGT-□G5□	SGDV-3R8A
		SGT-□F4□	
		SGT-□G6□	SGDV-5R5A
		SGT-□G7□	
	Σ -Trac- μ	SGTMM-01	SGDV-R70A
		SGTMM-03	SGDV-R90A
	Σ -Trac-MAG	SGTMF-4A	SGDV-1R6A
		SGTMF-4B	
		SGTMF-5A	SGDV-5R5A
		SGTMF-5B	



Σ -V Contents

Rotary Servomotors 1

SGMJV (Medium inertia, small capacity)	1
SGMAV (Low inertia, small capacity)	23
SGMGV (Medium inertia, medium capacity)	47
Rotary Servomotor General Instructions	67

Direct Drive Servomotors 75

SGMCS	75
-------	----

Linear Servomotors 89

SGLGW (Coreless type)	89
SGLFW (With F-type iron core)	101
SGLTW (With T-type iron core)	115
SGLCW (Cylinder type Σ -Stick)	131
Linear Servomotor General Instructions	145

Linear Sliders 153

Σ -Trac	153
----------------	-----

SERVOPACKs 165

SGDV- □□□□01/05(Analog voltage/pulse train reference type)*	165
SGDV- □□□□11/15(MECHATROLINK-II communications reference type)*	187

*: Compatible with fully-closed loop control

Wiring Main Circuit and Peripheral Devices 207

Connection to Host Controller 221

Rotary Servomotors

SGMJV



Model Designations

• Without Gears

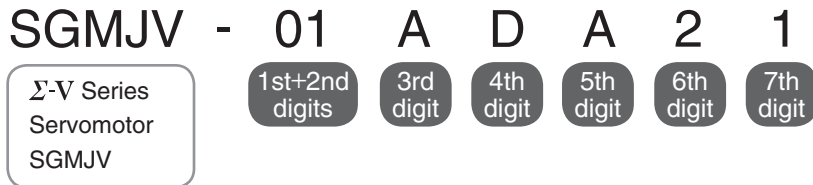

1st+2nd digits Rated Output

Code	Specifications
A5	50 W
01	100 W
02	200 W
04	400 W
08	750 W

3rd digit Power Supply Voltage

Code	Specifications
A	200 VAC

4th digit Serial Encoder

Code	Specifications
3	20-bit absolute (standard)
D	20-bit incremental (standard)
A	13-bit incremental (standard)

5th digit Design Revision Order

Code	Specifications
A	Standard

6th digit Shaft End

Code	Specifications
2	Straight without key (standard)
6	Straight with key and tap (optional)
8	Straight without key and with tap (optional)
B	With two flat seats (optional)

7th digit Options

Code	Specifications
1	Without options
C	With holding brake (24 VDC)
E	With oil seal and holding brake (24 VDC)
S	With oil seal

Features

- Medium inertia
- Instantaneous peak torque (350% of rated torque)
- Mounted high-resolution serial encoder: 13, 20 bits
- Maximum speed: 6,000 min⁻¹
- Wide Selection: 50 to 750 W capacity, holding brake and gear options

Application Examples

- Semiconductor equipment
- Chip mounters
- PCB drilling stations
- Robots
- Material handling machines
- Food processing equipment

● With Gears

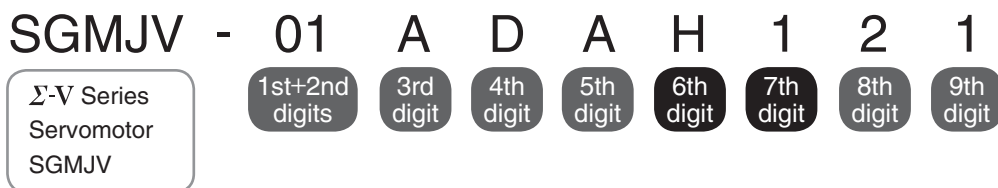

1st+2nd digits Rated Output

Code	Specifications
A5	50 W
01	100 W
02	200 W
04	400 W
08	750 W

3rd digit Power Supply Voltage

Code	Specifications
A	200 VAC

4th digit Serial Encoder

Code	Specifications
3	20-bit absolute (standard)
D	20-bit incremental (standard)
A	13-bit incremental (standard)

5th digit Design Revision Order

Code	Specifications
A	Standard

6th digit Gear Type

Code	Specifications
H	HDS planetary low-backlash gear

7th digit Gear Ratio

Code	Specifications
B	1/11 (Not available: 50 W)
C	1/21
1	1/5
2	1/9 (Only 50 W)
7	1/33

8th digit Shaft End

Code	Specifications
0	Flange output
2	Straight without key
6	Straight with key and tap
8	Straight without key and with tap

9th digit Options

Code	Specifications
1	Without options
C	With holding brake (24 VDC)

Ratings and Specifications

Time Rating: Continuous
Vibration Class: V15
Insulation Resistance: 500 VDC, 10 MΩ min.
Ambient Temperature: 0 to 40°C
Excitation: Permanent magnet
Mounting: Flange method

Thermal Class: B
Withstand Voltage: 1500 VAC for one minute
Enclosure: Totally enclosed, self-cooled, IP65
 (except for shaft opening)
Ambient Humidity: 20% to 80% (no condensation)
Drive Method: Direct drive
Rotation Direction: Counterclockwise (CCW)

Voltage		200 V				
Servomotor Model: SGMJV-□□□		A5A	01A	02A	04A	08A
Rated Output*1	W	50	100	200	400	750
Rated Torque*1, *2	N·m	0.159	0.318	0.637	1.27	2.39
Instantaneous Peak Torque*1	N·m	0.557	1.11	2.23	4.46	8.36
Rated Current*1	Arms	0.61	0.84	1.6	2.7	4.7
Instantaneous Max. Current*1	Arms	2.1	2.9	5.8	9.3	16.9
Rated Speed*1	min ⁻¹	3000				
Max. Speed*1	min ⁻¹	6000				
Torque Constant	N·m/Arms	0.285	0.413	0.435	0.512	0.544
Rotor Moment of Inertia	kg·m ² ×10 ⁻⁴	0.0414 (0.0489)	0.0665 (0.0740)	0.259 (0.323)	0.442 (0.506)	1.57 (1.74)
Rated Power Rate*1	kW/s	6.11	15.2	15.7	36.5	36.3
Rated Angular Acceleration*1	rad/s ²	38400	47800	24600	28800	15200
Applicable SERVOPACK	SGDV-□□□	R70	R90	1R6	2R8	5R5

*1: These items and torque-motor speed characteristics quoted in combination with an SGDV SERVOPACK are at an armature winding temperature of 100°C. Other values quoted are at 20°C.

*2: Rated torques are continuous allowable torque values at 40°C with an aluminum heat sink of the following dimensions attached.
 SGMJV-A5, -01: 200 mm×200 mm×6 mm
 SGMJV-02, -04, -08: 250 mm×250 mm×6 mm

Note: The values in parentheses are for servomotors with holding brakes.

● Torque-Motor Speed Characteristics A : Continuous Duty Zone B : Intermittent Duty Zone

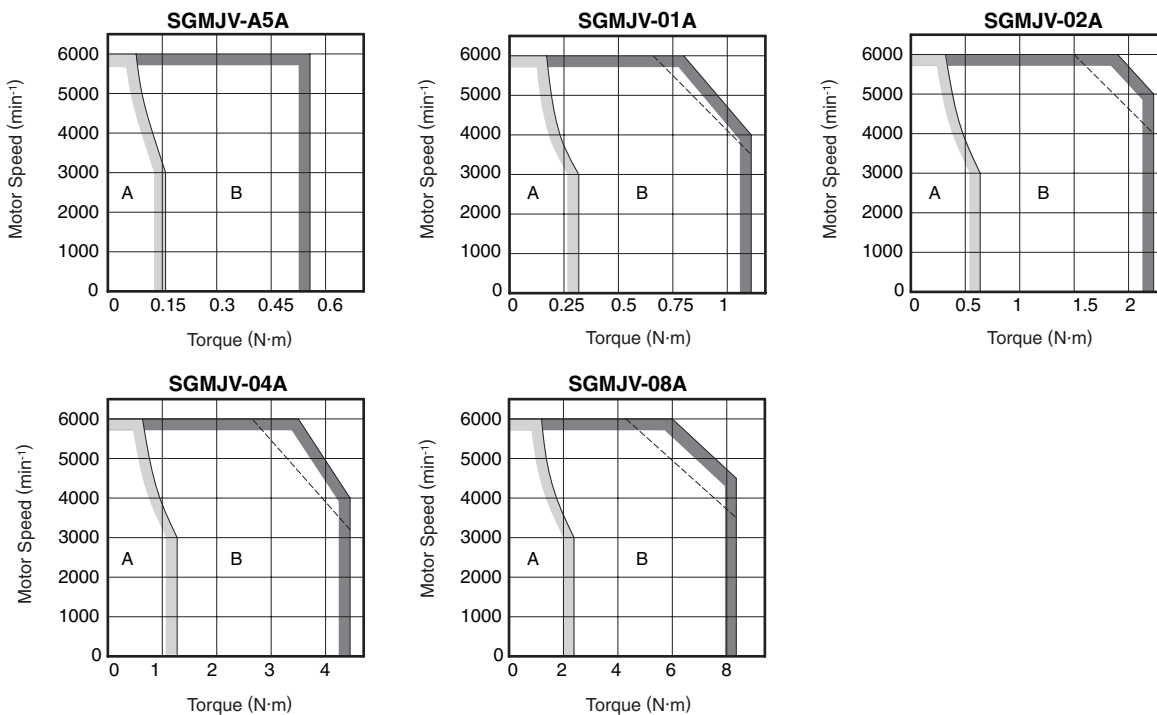

Notes: 1 The solid and dotted lines of the intermittent duty zone indicate the characteristics when a servomotor runs in the following combinations:
 · The solid line: With a three-phase 200 V or a single-phase 230 V SERVOPACK
 · The dotted line: With a single-phase 200 V SERVOPACK
 An SGMJV-A5 servomotor has the same characteristics in combination with three-phase and single-phase SERVOPACKS.
 2 The characteristics of the intermittent duty zone differ depending on the supply voltages.

Ratings and Specifications

● Derating Rate for Servomotor Fitted with an Oil Seal

When a motor is fitted with an oil seal, use the following derating rate because of the higher friction torque.

Servomotor Model SGMJV-	A5A	01A	02A	04A	08A
Derating Rate %	80	90		95	

● Holding Brake Electrical Specifications

Holding Brake Rated Voltage	Servomotor Model	Servomotor Rated Output W	Holding Brake Specifications					
			Capacity W	Holding Torque N·m	Coil Resistance Ω(at 20°C)	Rated Current A(at 20°C)	Brake Release Time ms	Brake Operation Time ms
24 VDC ^{+10%} ₀	SGMJV-A5A	50	6	0.159	96	0.25	60	100
	SGMJV-01A	100	6	0.318	96	0.25	60	100
	SGMJV-02A	200	6.9	0.637	83	0.29	60	100
	SGMJV-04A	400	6.9	1.27	83	0.29	60	100
	SGMJV-08A	750	7.7	2.39	75	0.32	80	100

Note: 1 The holding brake is only used to hold the load and cannot be used to stop the servomotor.

2 The holding brake open time and holding brake operation time vary depending on which discharge circuit is used. Make sure holding brake open time and holding brake operation time are correct for your servomotor.

● Overload Characteristics

The overload detection level is set under hot start conditions at a servomotor ambient temperature of 40°C.

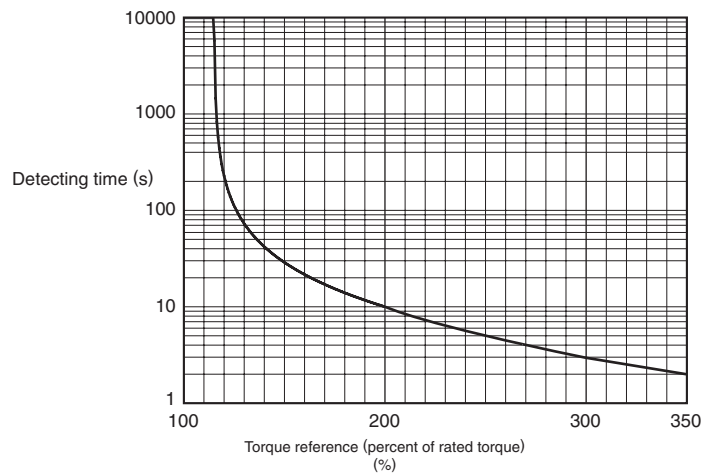

● Allowable Load Moment of Inertia at the Motor Shaft

The rotor moment of inertia ratio is the value for a servomotor without a gear and a brake.

Servomotor Model	Servomotor Rated Output	Allowable Load Moment of Inertia (Rotor Moment of Inertia Ratio)
SGMJV-	A5A, 01A, 02A	50 to 200 W
	04A, 08A	400 to 750 W

Ratings and Specifications

● Load Moment of Inertia

The larger the load moment of inertia, the worse the movement response of the load.

The allowable load moment of inertia (J_L) depends on motor capacity and is limited to within 5 to 30 times the rotor moment of inertia of each servomotor (J_M). This value is provided strictly as a guideline and results may vary depending on servomotor drive conditions.

An overvoltage alarm (A.400) is likely to occur during deceleration if the load moment of inertia exceeds the allowable load moment of inertia. SERVOPACKs with a built-in regenerative resistor may generate a regenerative overload alarm (A.320). Take one of the following steps if this occurs.

- Reduce the torque limit.
- Reduce the deceleration rate.
- Reduce the maximum speed.
- Install an external regenerative resistor if the alarm cannot be cleared. Contact your Yaskawa representative.

Regenerative resistors are not built into 400 W SGD V-2R8 SERVOPACKs.

The following figures show the relationship between the load moment of inertia and motor speed using an example with a load moment of inertia 10 to 15 times the rotor moment of inertia at the motor shaft.

External regenerative resistors are required when this condition is exceeded or if the allowable loss capacity (W) of the built-in regenerative resistor is exceeded due to regenerative drive conditions when a regenerative resistor is already built in.

● Load Moment of Inertia and Motor Speed

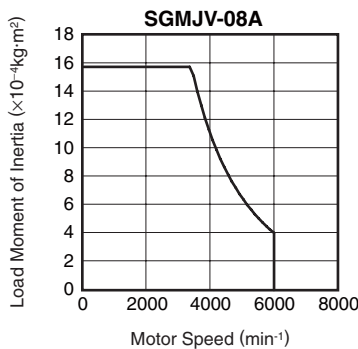
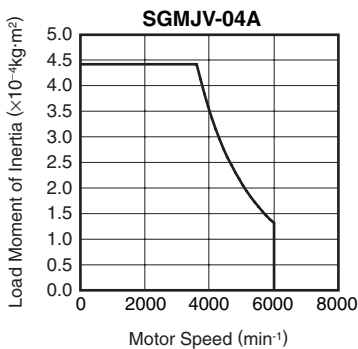
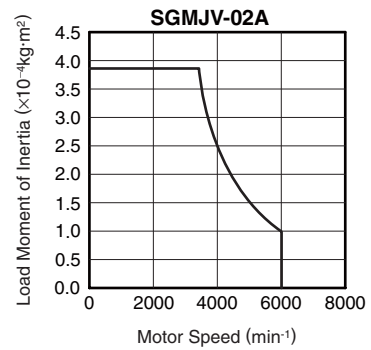
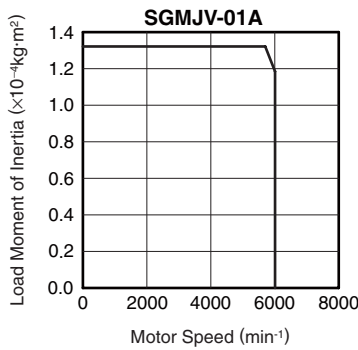
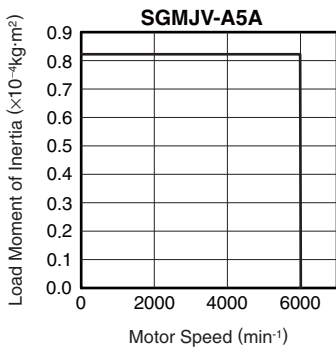

● Allowable Radial and Thrust Loads

Design the mechanical system so thrust and radial loads applied to the servomotor shaft end during operation fall within the ranges shown in the table.

Servomotor Model		Allowable Radial Load (F_r) N	Allowable Thrust Load (F_s) N	LR mm	Reference Diagram
SGMJV-	A5A	78	54	20	
	01A				
	02A	245	74	25	
	04A				
	08A				

External Dimensions Units: mm

● Without Holding Brakes (With Holding Brakes)

(1) 50 to 100 W

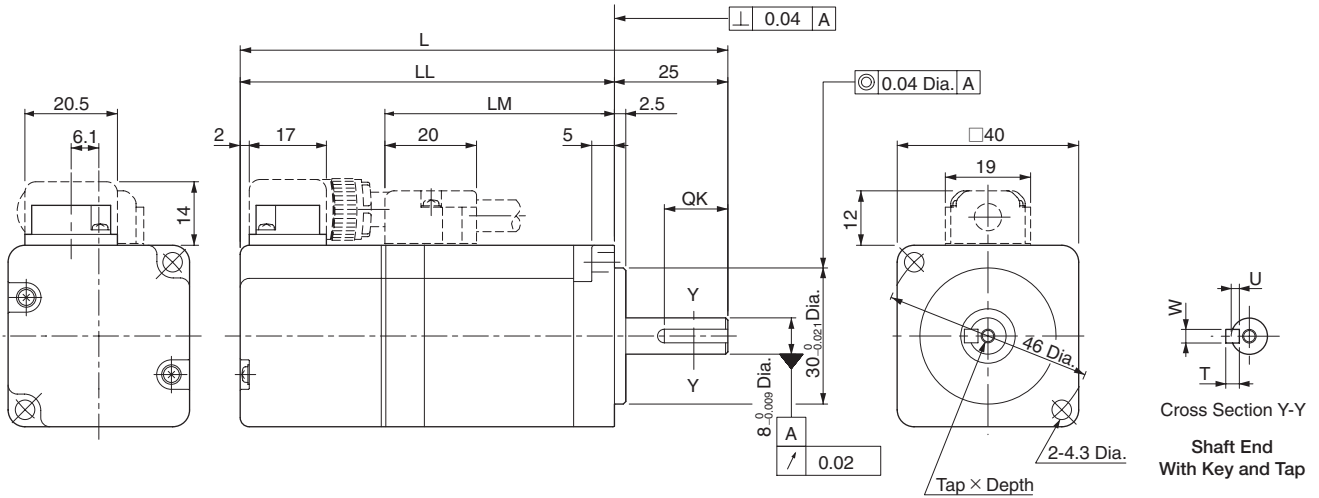

Model SGMJV-	L	LL	LM	Tap×Depth	Key Dimensions				Approx. Mass kg
					QK	U	W	T	
A5A□A21 (A5A□A2C)	94 (139)	69 (114)	37	No tap	No key				0.3 (0.6)
A5A□A61 (A5A□A6C)				M3×6L	14	1.8	3	3	
A5A□A81 (A5A□A8C)				No key					
01A□A21 (01A□A2C)	107.5 (152.5)	82.5 (127.5)	50.5	No tap	No key				0.4 (0.7)
01A□A61 (01A□A6C)				M3×6L	14	1.8	3	3	
01A□A81 (01A□A8C)				No key					

Note: The models and values in parentheses are for servomotors with holding brakes.

<Shaft End and Other Options>

● With Two Flat Seats

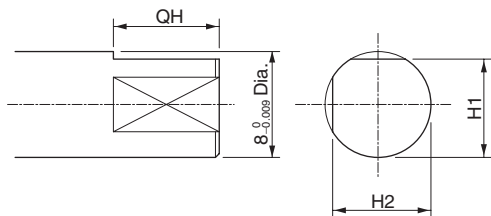

Model SGMJV-	Dimensions of Servomotor with Two Flat Seats mm		
	QH	H1	H2
A5A□AB1 (A5A□ABC)	15	7.5	7.5
01A□AB1 (01A□ABC)	15	7.5	7.5

Note: The models in parentheses are for servomotors with holding brakes.

● With an Oil Seal

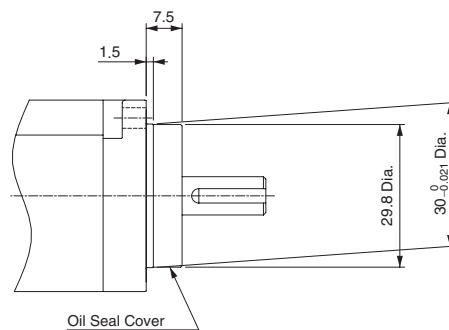

Notes: 1 The 7th digit of the model designation is "S" or "E".
2 Key dimensions are the same as those in the table above.

External Dimensions Units: mm

(2) 200 to 750 W

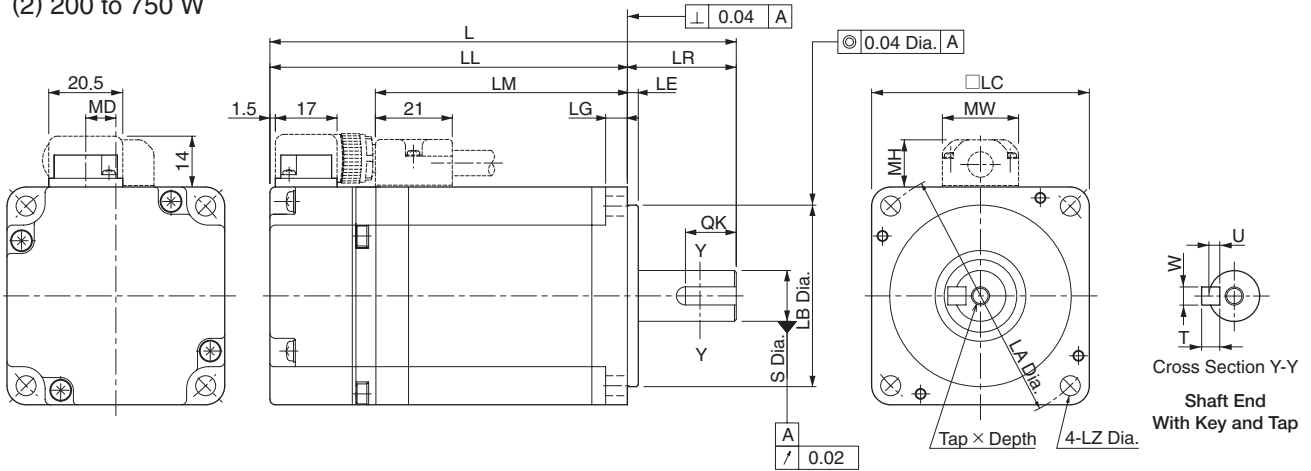

Model SGMJV-	L	LL	LM	Flange Face Dimensions							S	Tap× Depth	Key Dimensions				MD	MW	MH	Approx. Mass kg
				LR	LE	LG	LC	LA	LB	LZ			QK	U	W	T				
02A□A21 (02A□A2C)	110 (150)	80 (120)	51	30	3	6	60	70	50 ⁰ _{0.025}	5.5	14 ⁰ _{0.011}	No tap	No key				8.3	21	13	0.9 (1.5)
M5×8L												14	3	5	5					
No key																				
02A□A61 (02A□A6C)	128.5 (168.5)	98.5 (138.5)	69.5	30	3	6	60	70	50 ⁰ _{0.025}	5.5	14 ⁰ _{0.011}	No tap	No key				8.3	21	13	1.3 (1.9)
M5×8L												14	3	5	5					
No key																				
02A□A81 (02A□A8C)	155 (200)	115 (160)	85	40	3	8	80	90	70 ⁰ _{0.030}	7	19 ⁰ _{0.013}	No tap	No key				13.8	27	15	2.7 (3.6)
M6×10L												22	3.5	6	6					
No key																				

Note: The models and values in parentheses are for servomotors with holding brakes.

<Shaft End and Other Options>

● With Two Flat Seats

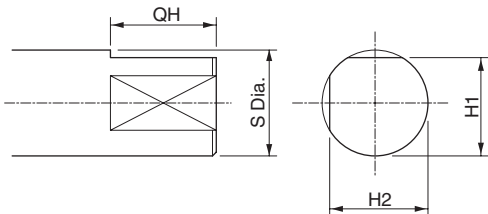

Model SGMJV-	Dimensions of Servomotor with Two Flat Seats mm			
	QH	S	H1	H2
02A□AB1 (02A□ABC)	15	14 ⁰ _{0.011}	13	13
04A□AB1 (04A□ABC)	15	14 ⁰ _{0.011}	13	13
08A□AB1 (08A□ABC)	22	19 ⁰ _{0.013}	18	18

● With an Oil Seal

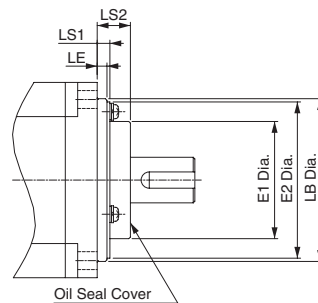

Model SGMJV-	Dimensions of Servomotor with an Oil Seal			
	E1	E2	LS1	LS2
02, 04	36	48	4	10
08	49	66	6	11

Notes: 1 The 7th digit of the model designation is "S" or "E".
2 Key dimensions are the same as those in the table above.

Selecting Cables

● Cables Connections

- Standard Wiring (Max. encoder cable length: 20 m)

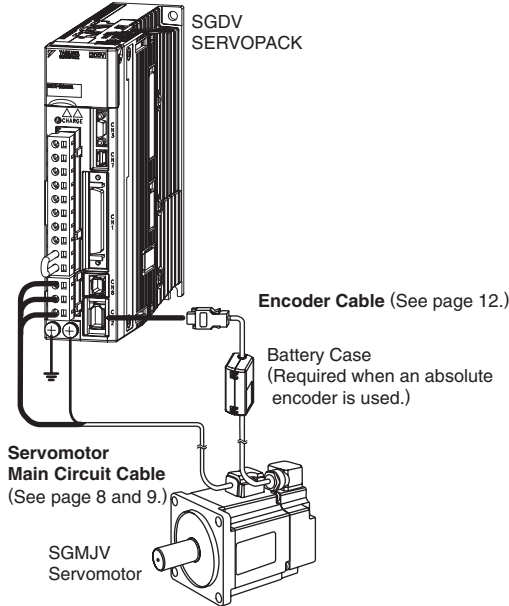

- Encoder Cable Extension from 30 to 50 m

(See page 14.)

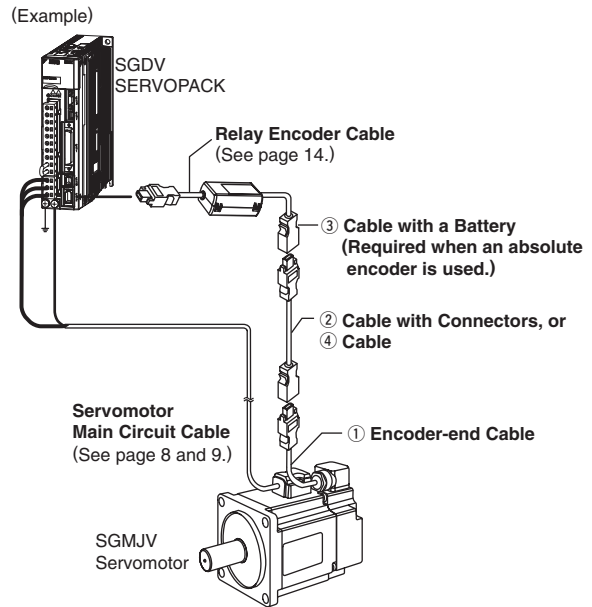

⚠ CAUTION

Separate the servomotor main circuit wiring from the signal line and encoder (PG) feedback line at least 30 cm, and do not bundle or run them in the same duct.



● Servomotor Main Circuit Cable

Contact Yaskawa Controls Co., Ltd.

Name	Servomotor Rated Output	Length	Order No.		Specifications	Details
			Standard Type	Flexible Type*		
For Servomotor without Holding Brakes	50 to 100 W	3 m	JZSP-CSM01-03-E	JZSP-CSM21-03-E		(1)
		5 m	JZSP-CSM01-05-E	JZSP-CSM21-05-E		
		10 m	JZSP-CSM01-10-E	JZSP-CSM21-10-E		
		15 m	JZSP-CSM01-15-E	JZSP-CSM21-15-E		
		20 m	JZSP-CSM01-20-E	JZSP-CSM21-20-E		
		30 m	JZSP-CSM01-30-E	JZSP-CSM21-30-E		
		40 m	JZSP-CSM01-40-E	JZSP-CSM21-40-E		
		50 m	JZSP-CSM01-50-E	JZSP-CSM21-50-E		
	200 to 400 W	3 m	JZSP-CSM02-03-E	JZSP-CSM22-03-E		
		5 m	JZSP-CSM02-05-E	JZSP-CSM22-05-E		
		10 m	JZSP-CSM02-10-E	JZSP-CSM22-10-E		
		15 m	JZSP-CSM02-15-E	JZSP-CSM22-15-E		
		20 m	JZSP-CSM02-20-E	JZSP-CSM22-20-E		
		30 m	JZSP-CSM02-30-E	JZSP-CSM22-30-E		
		40 m	JZSP-CSM02-40-E	JZSP-CSM22-40-E		
		50 m	JZSP-CSM02-50-E	JZSP-CSM22-50-E		
	750 W	3 m	JZSP-CSM03-03-E	JZSP-CSM23-03-E		
		5 m	JZSP-CSM03-05-E	JZSP-CSM23-05-E		
		10 m	JZSP-CSM03-10-E	JZSP-CSM23-10-E		
		15 m	JZSP-CSM03-15-E	JZSP-CSM23-15-E		
		20 m	JZSP-CSM03-20-E	JZSP-CSM23-20-E		
		30 m	JZSP-CSM03-30-E	JZSP-CSM23-30-E		
		40 m	JZSP-CSM03-40-E	JZSP-CSM23-40-E		
		50 m	JZSP-CSM03-50-E	JZSP-CSM23-50-E		

(Cont'd)

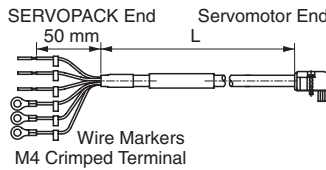
Selecting Cables

Name	Servomotor Rated Output	Length	Order No.		Specifications	Details
			Standard Type	Flexible Type*		
For Servomotor with Holding Brakes	50 to 100 W	3 m	JZSP-CSM11-03-E	JZSP-CSM31-03-E		(2)
		5 m	JZSP-CSM11-05-E	JZSP-CSM31-05-E		
		10 m	JZSP-CSM11-10-E	JZSP-CSM31-10-E		
		15 m	JZSP-CSM11-15-E	JZSP-CSM31-15-E		
		20 m	JZSP-CSM11-20-E	JZSP-CSM31-20-E		
		30 m	JZSP-CSM11-30-E	JZSP-CSM31-30-E		
		40 m	JZSP-CSM11-40-E	JZSP-CSM31-40-E		
	200 to 400 W	3 m	JZSP-CSM12-03-E	JZSP-CSM32-03-E		
		5 m	JZSP-CSM12-05-E	JZSP-CSM32-05-E		
		10 m	JZSP-CSM12-10-E	JZSP-CSM32-10-E		
		15 m	JZSP-CSM12-15-E	JZSP-CSM32-15-E		
		20 m	JZSP-CSM12-20-E	JZSP-CSM32-20-E		
		30 m	JZSP-CSM12-30-E	JZSP-CSM32-30-E		
		40 m	JZSP-CSM12-40-E	JZSP-CSM32-40-E		
	750 W	3 m	JZSP-CSM13-03-E	JZSP-CSM33-03-E		
		5 m	JZSP-CSM13-05-E	JZSP-CSM33-05-E		
		10 m	JZSP-CSM13-10-E	JZSP-CSM33-10-E		
		15 m	JZSP-CSM13-15-E	JZSP-CSM33-15-E		
		20 m	JZSP-CSM13-20-E	JZSP-CSM33-20-E		
		30 m	JZSP-CSM13-30-E	JZSP-CSM33-30-E		
		40 m	JZSP-CSM13-40-E	JZSP-CSM33-40-E		
Servomotor-end Connector Kit	50 to 100 W	JZSP-CSM9-1-E		Crimping Type (A crimp tool is required.)	(3)	
	200 to 400 W	JZSP-CSM9-2-E			(4)	
	750 W	JZSP-CSM9-3-E			(5)	
Cables	50 to 400 W	5 m	JZSP-CSM90-05-E	JZSP-CSM80-05-E		(6)
		10 m	JZSP-CSM90-10-E	JZSP-CSM80-10-E		
		15 m	JZSP-CSM90-15-E	JZSP-CSM80-15-E		
		20 m	JZSP-CSM90-20-E	JZSP-CSM80-20-E		
		30 m	JZSP-CSM90-30-E	JZSP-CSM80-30-E		
		40 m	JZSP-CSM90-40-E	JZSP-CSM80-40-E		
		50 m	JZSP-CSM90-50-E	JZSP-CSM80-50-E		
	750 W	5 m	JZSP-CSM91-05-E	JZSP-CSM81-05-E		(7)
		10 m	JZSP-CSM91-10-E	JZSP-CSM81-10-E		
		15 m	JZSP-CSM91-15-E	JZSP-CSM81-15-E		
		20 m	JZSP-CSM91-20-E	JZSP-CSM81-20-E		
		30 m	JZSP-CSM91-30-E	JZSP-CSM81-30-E		
		40 m	JZSP-CSM91-40-E	JZSP-CSM81-40-E		
		50 m	JZSP-CSM91-50-E	JZSP-CSM81-50-E		

*: Use flexible cables for movable sections such as robot arms.

(1) Wiring Specifications for Servomotors without Holding Brakes (2) Wiring Specifications for Servomotor with Holding Brakes

SERVOPACK-end Leads		Servomotor-end Connector	
Wire Color	Signal	Signal	Pin No.
Green/yellow	FG	FG	1
Blue	Phase W	Phase W	2
White	Phase V	Phase V	3
Red	Phase U	Phase U	4
		—	5
		—	6

SERVOPACK-end Leads		Servomotor-end Connector	
Wire Color	Signal	Signal	Pin No.
Green/yellow	FG	FG	1
Blue	Phase W	Phase W	2
White	Phase V	Phase V	3
Red	Phase U	Phase U	4
Black	Brake	Brake	5
Black	Brake	Brake	6

Note: No polarity for connection to a holding brake.

Selecting Cables

(3) Servomotor-end Connector Kit Specifications: For 50 to 100 W Servomotors

Items	Specifications	External Dimensions mm	
Order No.	JZSP-CSM9-1-E (Cables are not included.)		
Applicable Servomotors	SGMJV-A5, -01		
Manufacturer	J.S.T. Mfg. Co., Ltd.		
Receptacle	J17-06FMH-7KL-1-CF		
Electrical Contact	SJ1F-01GF-P0.8		
Applicable Wire Size	AWG20 to 24		
Outer Diameter of Insulating Sheath	1.11 dia. to 1.53 dia. mm		
Crimp Tool	Hand tool		YRS-8841
	Applicator		APLMK SJIF/M-01-08
Mounting Screw	M2 Pan-head screw		
Applicable Cable Outer Diameter	7±0.3 dia. mm		

(4) Servomotor-end Connector Kit Specifications: For 200 to 400 W Servomotors

Items	Specifications	External Dimensions mm	
Order No.	JZSP-CSM9-2-E (Cables are not included.)		
Applicable Servomotors	SGMJV-02, -04		
Manufacturer	J.S.T. Mfg. Co., Ltd.		
Receptacle	J27-06FMH-7KL-1-CF		
Electrical Contact	SJ2F-01GF-P1.0		
Applicable Wire Size	AWG20 to 24		
Outer Diameter of Insulating Sheath	1.11 dia. to 1.53 dia. mm		
Crimp Tool	Hand tool		YRS-8861
	Applicator		APLMK SJ2F/M-01-08
Mounting Screw	M2 Pan-head screw		
Applicable Cable Outer Diameter	7±0.3 dia. mm		

(5) Servomotor-end Connector Kit Specifications: For 750 W Servomotors

Items	Specifications	External Dimensions mm		
Order No.	JZSP-CSM9-3-E (Cables are not included.)			
Applicable Servomotors	SGMJV-08			
Manufacturer	J.S.T. Mfg. Co., Ltd.			
Receptacle	J37-06FMH-8KL-1-CF			
Cable Type	Standard			
Electrical Contact	SJ3F-41GF-P1.8 (For power terminals)		SJ3F-01GF-P1.8 (For brake terminals)	
	Applicable Wire Size		AWG16 to 20	AWG20 to 24
Outer Diameter of Insulating Sheath	1.53 dia. to 2.5 dia. mm		1.11 dia. to 1.86 dia. mm	
Crimp Tool	Hand tool		YRF-880	YRF-881
	Applicator		APLMK SF3F/M-41-20	APLMK SF3F/M-01-20
Mounting Screw	M2.5 Pan-head screw			
Applicable Cable Outer Diameter	8±0.3 dia. mm			

Selecting Cables

(6) Cable Specifications: For 50 to 400 W Servomotors

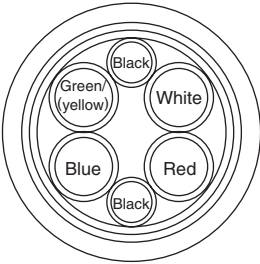
Items	Standard Type	Flexible Type
Order No.*	JZSP-CSM90-□□-E (50 m max.)	JZSP-CSM80-□□-E (50 m max.)
Specifications	UL2517 (Max. operating temperature: 105°C) AWG20×6C For power line: AWG20 (0.52 mm ²) Outer diameter of insulating sheath: 1.53 dia. mm For holding brake line: AWG20 (0.52 mm ²) Outer diameter of insulating sheath: 1.53 dia. mm	UL2517 (Max. operating temperature: 105°C) AWG22×6C For power line: AWG22 (0.33 mm ²) Outer diameter of insulating sheath: 1.37 dia. mm For holding brake line: AWG22 (0.33 mm ²) Outer diameter of insulating sheath: 1.37 dia. mm
Finished Dimensions	7±0.3 dia. mm	
Internal Configuration and Lead Color		
Yaskawa Standard Specifications (Standard Length)	Cable length: 5 m, 10 m, 15 m, 20 m, 30 m, 40 m, 50 m	

*: Specify the cable length in □□ of order no.
 Example: JZSP-CSM90-05-E (5 m)

(7) Cable Specifications: For 750 W Servomotors

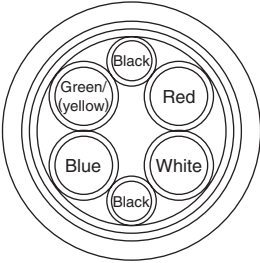
Items	Standard Type	Flexible Type
Order No.*	JZSP-CSM91-□□-E (50 m max.)	JZSP-CSM81-□□-E (50 m max.)
Specifications	UL2517 (Max. operating temperature: 105°C) AWG16×4C, AWG20×2C For power line: AWG16 (1.31 mm ²) Outer diameter of insulating sheath: 2.15 dia. mm For holding brake line: AWG20 (0.52 mm ²) Outer diameter of insulating sheath: 1.6 dia. mm	UL2517 (Max. operating temperature: 105°C) AWG16×4C, AWG22×2C For power line: AWG16 (1.31 mm ²) Outer diameter of insulating sheath: 2.35 dia. mm For holding brake line: AWG22 (0.33 mm ²) Outer diameter of insulating sheath: 1.37 dia. mm
Finished Dimensions	8±0.3 dia. mm	
Internal Configuration and Lead Color		
Yaskawa Standard Specifications (Standard Length)	Cable length: 5 m, 10 m, 15 m, 20 m, 30 m, 40 m, 50 m	

*: Specify the cable length in □□ of order no.
 Example: JZSP-CSM91-05-E (5 m)

Selecting Cables

● Encoder Cables (Length: 20 m or less)

Contact Yaskawa Controls Co., Ltd.

Name	Length	Order No.		Specifications	Details
		Standard Type	Flexible Type*		
Cable with Connectors (For Incremental Encoder)	3 m	JZSP-CSP01-03-E	JZSP-CSP21-03-E		(1)
	5 m	JZSP-CSP01-05-E	JZSP-CSP21-05-E		
	10 m	JZSP-CSP01-10-E	JZSP-CSP21-10-E		
	15 m	JZSP-CSP01-15-E	JZSP-CSP21-15-E		
	20 m	JZSP-CSP01-20-E	JZSP-CSP21-20-E		
Cable with Connectors (For Absolute Encoder, with a Battery Case)	3 m	JZSP-CSP05-03-E	JZSP-CSP25-03-E		(2)
	5 m	JZSP-CSP05-05-E	JZSP-CSP25-05-E		
	10 m	JZSP-CSP05-10-E	JZSP-CSP25-10-E		
	15 m	JZSP-CSP05-15-E	JZSP-CSP25-15-E		
	20 m	JZSP-CSP05-20-E	JZSP-CSP25-20-E		
SERVOPACK-end Connector Kit		JZSP-CMP9-1-E		Soldered	(3)
Encoder-end Connector Kit		JZSP-CSP9-2-E		Crimping Type (A crimp tool is required.)	
Cables	3 m	JZSP-CMP09-03-E	JZSP-CSP39-03-E		(4)
	5 m	JZSP-CMP09-05-E	JZSP-CSP39-05-E		
	10 m	JZSP-CMP09-10-E	JZSP-CSP39-10-E		
	15 m	JZSP-CMP09-15-E	JZSP-CSP39-15-E		
	20 m	JZSP-CMP09-20-E	JZSP-CSP39-20-E		

*: Use flexible cables for movable sections such as robot arms.

Note: When the battery from the host controller is used for the absolute encoder, no battery case is required. In this case, use a cable for the incremental encoders.

(1) Wiring Specifications for Cable with Connectors
(For incremental encoder)

• Standard Type

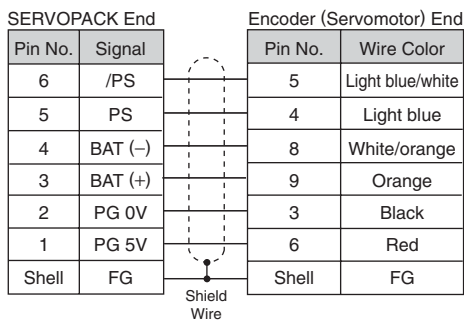

• Flexible Type

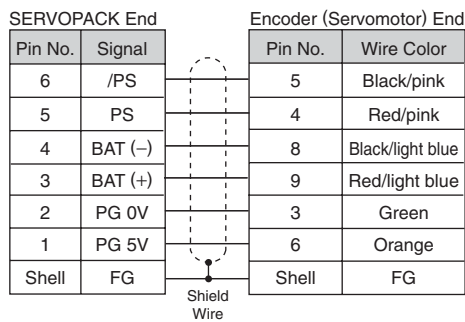

(2) Wiring Specifications for Cable with Connectors
(For absolute encoder, with a battery case)

• Standard Type

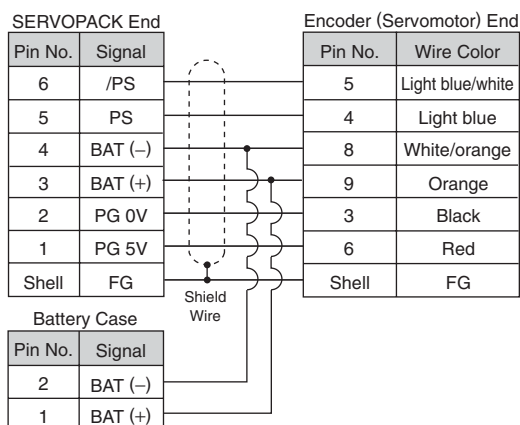

• Flexible Type

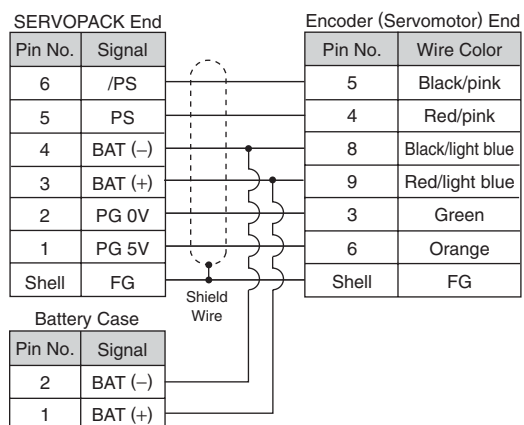

Selecting Cables

(3) SERVOPACK-end/Encoder-end Connector Kit Specifications

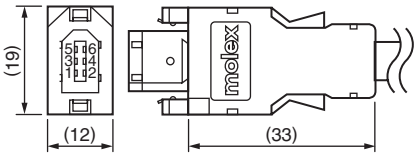
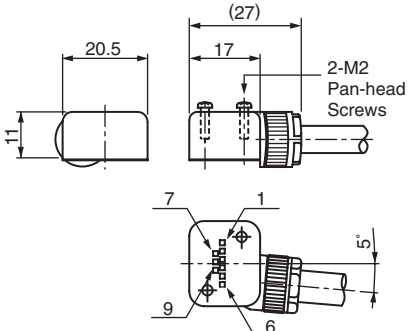
Items	SERVOPACK-end Connector Kit	Encoder-end Connector Kit
Order No.	JZSP-CMP9-1-E (Cables are not included.)	JZSP-CSP9-2-E (Cables are not included.)
Manufacturer	Molex Japan Co., Ltd.	Molex Japan Co., Ltd.
Specifications	55100-0670 (soldered) Note: Contact Molex Japan Co., Ltd. for 55102-0600 connectors (caulking).	54346-0070 (crimped)* Mounting screw: M2 pan-head screw (× 2) Applicable cable outer diameter of applicable cable: 6.3 dia. to 7.7 dia. mm Applicable wire size: AWG22 to 26 Outer diameter of insulating sheath: 1.05 dia. to 1.4 dia. mm
External Dimensions (Units: mm)		

*: A crimp tool is required.

The following crimp tools are applicable for the cables provided by Yaskawa. When using other wire sizes, contact the respective manufacturer for crimp tools.

Applicable crimp tool for Yaskawa's wire size: Hand Tool Model No. 57175-5000
Applicator Model No. 57175-3000

(4) Cable Specifications

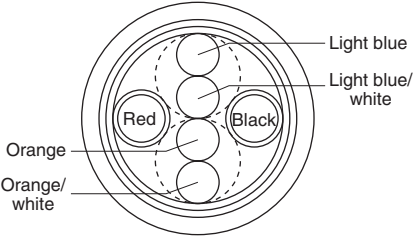
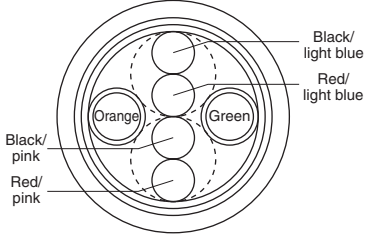
Items	Standard Type	Flexible Type
Order No.*	JZSP-CMP09-□□-E	JZSP-CSP39-□□-E
Cable Length	20 m max.	
Specifications	UL20276 (Max. operating temperature: 80°C) AWG22×2C+AWG24×2P AWG22 (0.33 mm ²) Outer diameter of insulating sheath: 1.15 dia. mm AWG24 (0.20 mm ²) Outer diameter of insulating sheath: 1.09 dia. mm	UL20276 (Max. operating temperature: 80°C) AWG22×2C+AWG24×2P AWG22 (0.33 mm ²) Outer diameter of insulating sheath: 1.35 dia. mm AWG24 (0.20 mm ²) Outer diameter of insulating sheath: 1.21 dia. mm
Finished Dimensions	6.5 dia. mm	6.8 dia. mm
Internal Configuration and Lead Color		
Yaskawa Standards Specifications (Standard Length)	Cable length: 5 m, 10 m, 15 m, 20 m	

*: Specify the cable length in □□ of order no.
Example: JZSP-CSP09-05-E (5 m)

Selecting Cables

● Relay Encoder Cables (For extending from 30 to 50 m)

Name	Length	Order No.	Specifications	Details
		Standard Type		
① Encoder-end Cables (For incremental and absolute encoder)	0.3 m	JZSP-CSP11-E	<p>SERVOPACK End 0.3 m Encoder End</p> <p>Plug Connector (Crimped) (Molex Japan Co., Ltd.) Connector (Molex Japan Co., Ltd.)</p>	(1)
② Cable with Connectors (For incremental and absolute encoder)	30 m	JZSP-UCMP00-30-E	<p>SERVOPACK End L Encoder End</p> <p>Plug Connector (Crimped) (Molex Japan Co., Ltd.) Socket Connector (Soldered) (Molex Japan Co., Ltd.)</p>	(2)
	40 m	JZSP-UCMP00-40-E		
	50 m	JZSP-UCMP00-50-E		
③ Cable with a Battery Case (For absolute encoder)	0.3 m	JZSP-CSP12-E*	<p>SERVOPACK End 0.3 m Encoder End</p> <p>Plug Connector (Crimped) (Molex Japan Co., Ltd.) Socket Connector (Soldered) (Molex Japan Co., Ltd.)</p>	(3)
④ Cables	30 m	JZSP-CMP19-30-E		(4)
	40 m	JZSP-CMP19-40-E		
	50 m	JZSP-CMP19-50-E		

*: When using an incremental encoder or using an absolute encoder with a battery connected to the host controller, no battery case is required.

(1) Wiring Specifications for Encoder-end Cable (For incremental and absolute encoder)

SERVOPACK End		Encoder (Servomotor) End	
Pin No.	Signal	Pin No.	Wire Color
6	/PS	5	Light blue/white
5	PS	4	Light blue
4	BAT (-)	8	White/orange
3	BAT (+)	9	Orange
2	PG 0V	3	Black
1	PG 5V	6	Red
Shell	FG	Shell	FG

(2) Wiring Specifications for Cable with Connectors (For incremental and absolute encoder)

SERVOPACK End		Encoder (Servomotor) End	
Pin No.	Signal	Pin No.	Wire Color
6	/PS	6	Light blue/white
5	PS	5	Light blue
4	BAT (-)	4	White/orange
3	BAT (+)	3	Orange
2	PG 0V	2	Black
1	PG 5V	1	Red
Shell	FG	Shell	FG

(3) Wiring Specifications for Cable with a Battery Case (For absolute encoder)

SERVOPACK End		Encoder (Servomotor) End	
Pin No.	Signal	Pin No.	Wire Color
6	/PS	6	Light blue/white
5	PS	5	Light blue
4	BAT (-)	4	White/orange
3	BAT (+)	3	Orange
2	PG 0V	2	Black
1	PG 5V	1	Red
Shell	FG	Shell	FG

Battery Case	
Pin No.	Signal
2	BAT (-)
1	BAT (+)

(4) Relay Encoder Cable Specifications

Item	Standard Type
Order No.*	JZSP-CMP19-□□-E
Cable Length	50 m max.
Specifications	UL20276 (Max. operating temperature: 80°C) AWG16×2C+AWG26×2P AWG16 (1.31 mm ²) Outer diameter of insulating sheath: 2.0 dia. mm AWG26 (0.13 mm ²) Outer diameter of insulating sheath: 0.91 dia. mm
Finished Dimensions	6.8 dia. mm
Internal Configuration and Lead Colors	
Yaskawa Standard Specifications (Standard Length)	Cable length: 30 m, 40 m, 50 m

*: Specify the cable length in □□ of order no.
Example: JZSP-CMP19-30-E (30 m)

With Low-backlash Gears

Ratings and Specifications

Time Rating: Continuous
Insulation Resistance: 500 VDC, 10 MΩ min.
Ambient Temperature: 0 to 40°C
Excitation: Permanent magnet
Mounting: Flange method
Gear Mechanism: Planetary gear mechanism
Thermal Class: B

Withstand Voltage: 1500 VAC for one minute
Enclosure: Totally enclosed, self-cooled, IP55
 (except for shaft opening)
Ambient Humidity: 20% to 80% (no condensation)
Drive Method: Direct drive
Rotation Direction: Counterclockwise (CCW)

Servomotor Model SGMJV-	Servomotor					Gear					
	Rated Output W	Rated Speed min ⁻¹	Max. Speed min ⁻¹	Rated Torque N·m	Instantaneous Peak Torque N·m	Gear Ratio	Lost Motion arc-min	Rated Torque / Efficiency* ¹ N·m / %	Instantaneous Peak Torque N·m	Rated Speed min ⁻¹	Max. Speed min ⁻¹
A5A□AH1□	50	3000	6000	0.159	0.557	1/5	3 max.	0.557/70	2.40	600	1200
A5A□AH2□						1/9		1.15/80	3.80* ²	333	667
A5A□AHC□						1/21		2.67/80	10.6	143	286
A5A□AH7□						1/33		3.68/70	15.8	91	182
01A□AH1□	100	3000	6000	0.318	1.11	1/5	3 max.	1.35/85	5.00	600	1200
01A□AHB□						1/11		2.45/70	10.6	273	545
01A□AHC□						1/21		5.35/80	20.7	143	286
01A□AH7□						1/33		7.35/70	31.9	91	182
02A□AH1□	200	3000	6000	0.637	2.23	1/5	3 max.	2.39/75	9.80	600	1200
02A□AHB□						1/11		5.60/80	22.1	273	545
02A□AHC□						1/21		10.0/75	42.3	143	286
02A□AH7□						1/33		16.8/80	67.4	91	182
04A□AH1□	400	3000	6000	1.27	4.46	1/5	3 max.	5.41/85	20.1	600	1200
04A□AHB□						1/11		11.2/80	45.0	273	545
04A□AHC□						1/21		22.7/85	87.1	143	286
04A□AH7□						1/33		33.6/80	135	91	182
08A□AH1□	750	3000	6000	2.39	8.36	1/5	3 max.	10.2/85	38.6	600	1200
08A□AHB□						1/11		23.6/90	86.4	273	545
08A□AHC□						1/21		42.6/85	163	143	286
08A□AH7□						1/33		70.9/90	259	91	182

*1: Gear output torque is expressed using the following equation.

$$(\text{Gear output torque}) = (\text{Servomotor output torque}) \times \frac{1}{(\text{gear ratio})} \times (\text{efficiency})$$

*2: Peak torque is 300%

Note: The no-load torque for a servomotor with a gear is high immediately after the servomotor starts, and it then decreases and becomes stable a few minutes later. This is a common phenomenon caused by grease being circulated in the gear and not by a faulty gear.

IMPORTANT The SERVOPACK speed control range is 5000:1. When using servomotors at extremely low speeds (0.02 min⁻¹ at gear output shaft), when using servomotors with one pulse feed reference for extended periods and in some other situations, the gear bearing lubrication may be insufficient. That may cause deterioration of bearing or increase the load ratio. Contact your Yaskawa representative if you are using your servomotor under these conditions.

With Low-backlash Gears Ratings and Specifications

● **Moment of Inertia and Allowable Radial and Thrust Loads**

Servomotor Model SGMJV-	Moment of Inertia $\times 10^{-4}$ kg·m ²				Servomotors with Low-backlash Gears			Reference Diagram
	Motor + Gear	Gear	Flange Output		Allowable Radial Load (Fr) N	Allowable Thrust Load (Fs) N	LR mm	
			Motor + Gear	Gear				
A5A□AH1□	0.0474	0.006	0.0464	0.005	95	431	37	
A5A□AH2□	0.0444	0.003	0.0444	0.003	113	514	37	
A5A□AHC□	0.0454	0.004	0.0454	0.004	146	663	37	
A5A□AH7□	0.0864	0.045	0.0864	0.045	267	1245	53	
01A□AH1□	0.0715	0.005	0.0705	0.004	95	431	37	
01A□AHB□	0.127	0.060	0.126	0.059	192	895	53	
01A□AHC□	0.117	0.050	0.117	0.050	233	1087	53	
01A□AH7□	0.132	0.065	0.131	0.064	605	2581	75	
02A□AH1□	0.466	0.207	0.460	0.201	152	707	53	
02A□AHB□	0.452	0.193	0.451	0.192	192	895	53	
02A□AHC□	0.749	0.490	0.747	0.488	528	2254	75	
02A□AH7□	0.709	0.450	0.708	0.449	605	2581	75	
04A□AH1□	0.649	0.207	0.643	0.201	152	707	53	
04A□AHB□	1.01	0.570	1.00	0.560	435	1856	75	
04A□AHC□	0.932	0.490	0.930	0.488	528	2254	75	
04A□AH7□	1.06	0.620	1.05	0.610	951	4992	128	
08A□AH1□	2.27	0.700	2.23	0.660	343	1465	75	
08A□AHB□	2.17	0.600	2.16	0.590	435	1856	75	
08A□AHC□	4.57	3.00	4.55	2.98	830	4359	128	
08A□AH7□	4.37	2.80	4.36	2.79	951	4992	128	

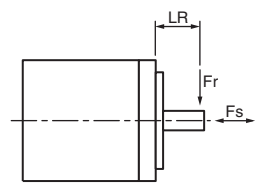

Rotary Servomotors

● Without Holding Brakes(With Holding Brakes)

(1) 50 to 100 W

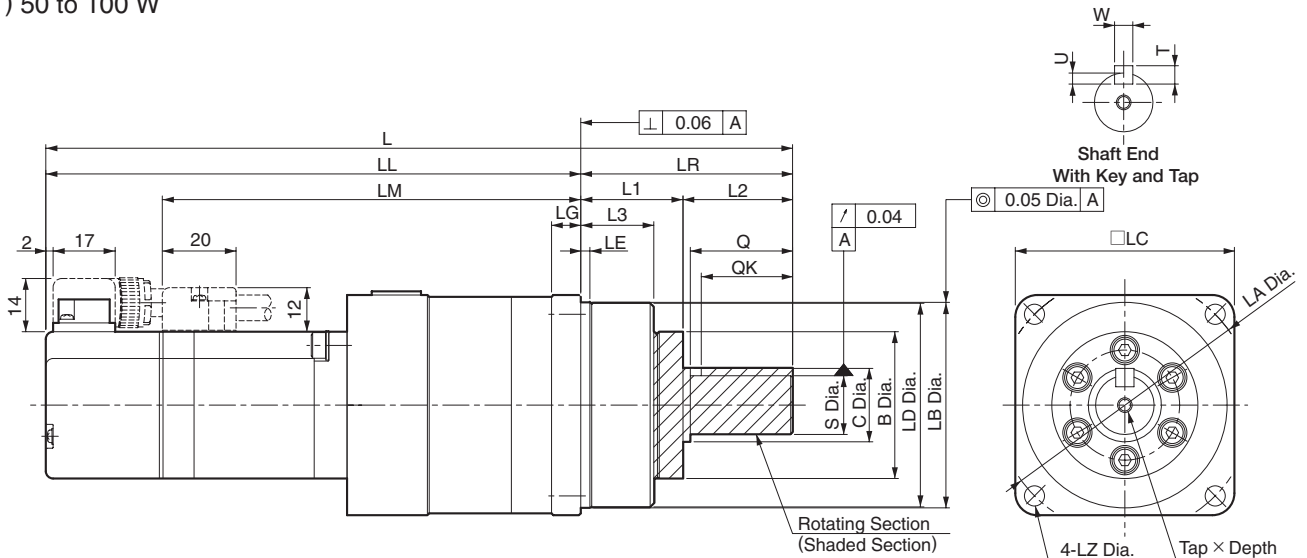

Model SGMJV-	Gear Ratio	L	LL	LM	Flange Face Dimensions								
					LR	LE	LG	B	LD	LB	LC	LA	LZ
A5A□AH1※1 (A5A□AH1※C)	1/5	150.5 (195.5)	108.5 (153.5)	76.5	42	2.2	5	29	39.5	40 ⁰ _{0.025}	40	46	3.4
A5A□AH2※1 (A5A□AH2※C)	1/9												
A5A□AHC※1 (A5A□AHC※C)	1/21	159.5 (204.5)	117.5 (162.5)										
A5A□AH7※1 (A5A□AH7※C)	1/33	191 (236)	133 (178)	101	58	2.5	8	40	55.5	56 ⁰ _{0.030}	60	70	5.5
01A□AH1※1 (01A□AH1※C)	1/5	164 (209)	122 (167)	90	42	2.2	5	29	39.5	40 ⁰ _{0.025}	40	46	3.4
01A□AHB※1 (01A□AHB※C)	1/11	204.5 (249.5)	146.5 (191.5)	114.5	58	2.5	8	40	55.5	56 ⁰ _{0.030}	60	70	5.5
01A□AHC※1 (01A□AHC※C)	1/21												
01A□AH7※1 (01A□AH7※C)	1/33	229 (274)	149 (194)	117	80	7.5	10	59	84	85 ⁰ _{0.035}	90	105	9

Model SGMJV-	L1	L2	L3	Q	C	S (Shaft)	Tap×Depth	Key Dimensions				Approx. Mass kg
								QK	U	W	T	
A5A□AH1※1 (A5A□AH1※C)	22	20	14	20	-	8 ⁰ _{0.015}	M3×6L	15	1.8	3	3	0.6 (0.9)
A5A□AH2※1 (A5A□AH2※C)	22	20	14									
A5A□AHC※1 (A5A□AHC※C)	22	20	14									
A5A□AH7※1 (A5A□AH7※C)	28	30	20	28	20	16 ⁰ _{0.018}	M4×8L	25	3	5	5	1.3 (1.6)
01A□AH1※1 (01A□AH1※C)	22	20	14	20	-	8 ⁰ _{0.015}	M3×6L	15	1.8	3	3	0.7 (1.0)
01A□AHB※1 (01A□AHB※C)	28	30	20	28	20	16 ⁰ _{0.018}	M4×8L	25	3	5	5	1.4 (1.7)
01A□AHC※1 (01A□AHC※C)	28	30	20									
01A□AH7※1 (01A□AH7※C)	36	44	26									

: The asterisk () describes the values of the 8th digit of the model designation, "shaft end code 6 (straight with key and tap)." If a key or tap is not necessary, order a servomotor with "shaft end code 2 (without key and tap)" or "shaft end code 8 (without key and with tap)."

Notes: 1 The models and values in parentheses are for servomotors with holding brakes.

2 Please note that gear dimensions are different from those of Σ-I, Σ-II, and Σ-III series.

With Low-backlash Gears External Dimensions Units: mm

● Flange Output Face

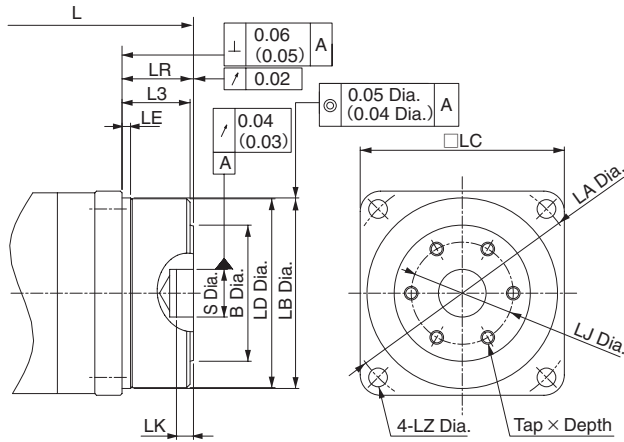

Model SGMJV-	Gear Ratio	L	LR	LJ	LK	S (Hole)	Tap×Depth	Approx. Mass kg	
A5A□AH101 (A5A□AH10C)	1/5	123.5 (168.5)	15	18	3	$8^{+0.015}_0$	3-M4×6L	0.6 (0.9)	
A5A□AH201 (A5A□AH20C)	1/9	123.5 (168.5)	15	18	3		3-M4×6L	0.6 (0.9)	
A5A□AHC01 (A5A□AHC0C)	1/21	132.5 (177.5)	15	18	3		3-M4×6L	0.6 (0.9)	
A5A□AH701 (A5A□AH70C)	1/33	154 (199)	21	30	5	$16^{+0.018}_0$	6-M4×7L	1.2 (1.5)	
01A□AH101 (01A□AH10C)	1/5	137 (182)	15	18	3	$8^{+0.015}_0$	3-M4×6L	0.7 (1.0)	
01A□AHB01 (01A□AHB0C)	1/11	167.5 (212.5)	21	30	5		$16^{+0.018}_0$	3-M4×7L	1.3 (1.6)
01A□AHC01 (01A□AHC0C)	1/21	167.5 (212.5)	21	30	5			3-M4×7L	1.3 (1.6)
01A□AH701 (01A□AH70C)	1/33	176 (221)	27	45	5	$25^{+0.021}_0$	6-M6×10L	2.4 (2.7)	

Notes: 1 The models and values in parentheses are for servomotors with holding brakes.
2 Dimensions not found in the table above are the same as those in the table on the previous page.

(2) 200 to 400 W

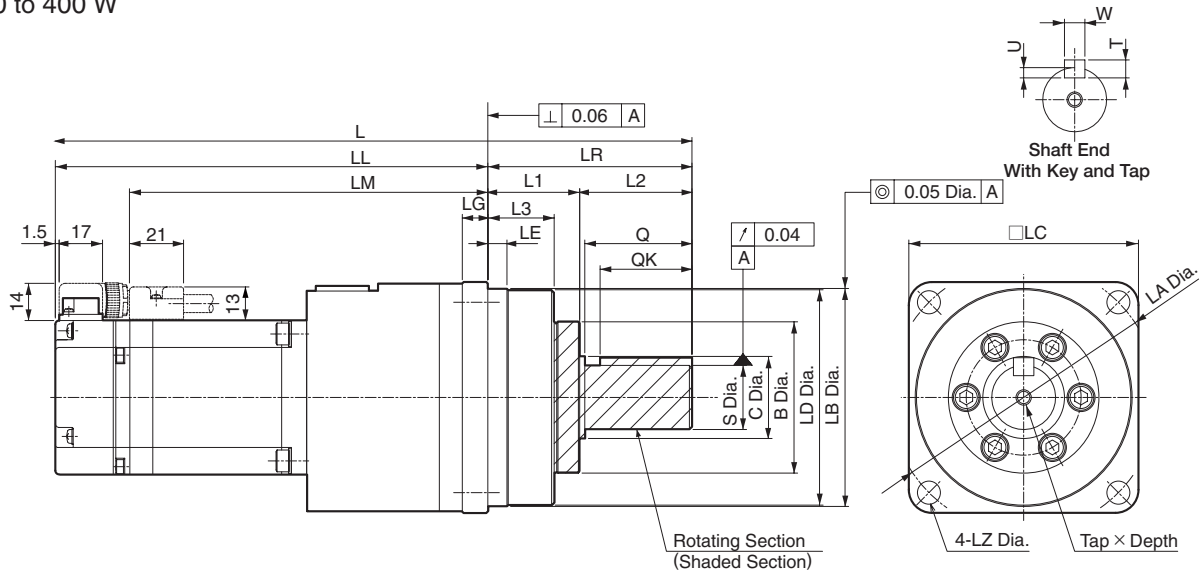

Model SGMJV-	Gear Ratio	L	LL	LM	Flange Face Dimensions								
					LR	LE	LG	B	LD	LB	LC	LA	LZ
02A□AH1※1 (02A□AH1※C)	1/5	202 (242)	144 (184)	115	58	2.5	8	40	55.5	56 ⁰ _{-0.030}	60	70	5.5
02A□AHB※1 (02A□AHB※C)	1/11												
02A□AHC※1 (02A□AHC※C)	1/21	231 (271)	151 (191)	122	80	7.5	10	59	84	85 ⁰ _{-0.035}	90	105	9
02A□AH7※1 (02A□AH7※C)	1/33												
04A□AH1※1 (04A□AH1※C)	1/5	220.5 (260.5)	162.5 (202.5)	133.5	58	2.5	8	40	55.5	56 ⁰ _{-0.030}	60	70	5.5
04A□AHB※1 (04A□AHB※C)	1/11	249.5 (289.5)	169.5 (209.5)	140.5	80	7.5	10	59	84	85 ⁰ _{-0.035}	90	105	9
04A□AHC※1 (04A□AHC※C)	1/21												
04A□AH7※1 (04A□AH7※C)	1/33	335.5 (375.5)	202.5 (242.5)	173.5	133	12.5	13	84	114	115 ⁰ _{-0.035}	120	135	11

Model SGMJV-	L1	L2	L3	Q	C	S (Shaft)	Tap×Depth	Key Dimensions				Approx. Mass kg
								QK	U	W	T	
02A□AH1※1 (02A□AH1※C)	28	30	20	28	20	16 ⁰ _{-0.018}	M4×8L	25	3	5	5	1.9 (2.5)
02A□AHB※1 (02A□AHB※C)												2.0 (2.6)
02A□AHC※1 (02A□AHC※C)	36	44	26	42	32	25 ⁰ _{-0.021}	M6×12L	36	4	8	7	3.8 (4.4)
02A□AH7※1 (02A□AH7※C)												
04A□AH1※1 (04A□AH1※C)	28	30	20	28	20	16 ⁰ _{-0.018}	M4×8L	25	3	5	5	2.3 (2.9)
04A□AHB※1 (04A□AHB※C)	36	44	26	42	32	25 ⁰ _{-0.021}	M6×12L	36	4	8	7	4.2 (4.8)
04A□AHC※1 (04A□AHC※C)	36	44	26									
04A□AH7※1 (04A□AH7※C)	48	85	33	82	44	40 ⁰ _{-0.025}	M10×20L	70	5	12	8	8.8 (9.4)

: The asterisk () describes the values of the 8th digit of the model designation, "shaft end code 6 (straight with key and tap)." If a key or tap is not necessary, order a servomotor with "shaft end code 2 (without key and tap)" or "shaft end code 8 (without key and with tap)."

Notes: 1 The models and values in parentheses are for servomotors with holding brakes.

2 Please note that gear dimensions are different from those of Σ-I, Σ-II, and Σ-III series.

With Low-backlash Gears External Dimensions Units: mm

● Flange Output Face

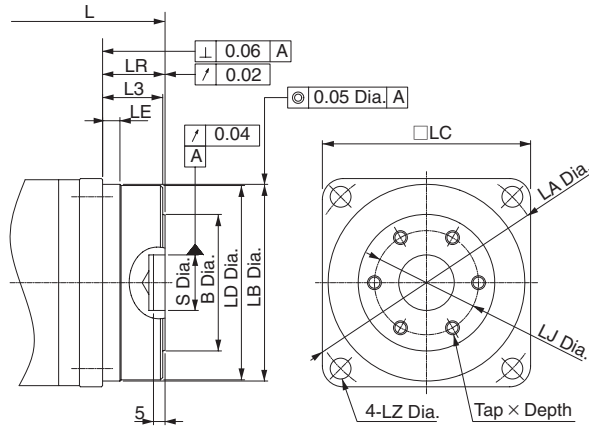

Model SGMJV-	Gear Ratio	L	LR	LJ	S (Hole)	Tap x Depth	Approx. Mass kg
02A□AH101 (02A□AH10C)	1/5	165 (205)	21	30	$16^{+0.018}_0$	6-M4 x 7L	1.8 (2.4)
02A□AHB01 (02A□AHB0C)	1/11						1.9 (2.5)
02A□AHC01 (02A□AHC0C)	1/21	178 (218)	27	45	$25^{+0.021}_0$	6-M6 x 10L	3.4 (4.0)
02A□AH701 (02A□AH70C)	1/33						
04A□AH101 (04A□AH10C)	1/5	183.5 (223.5)	21	30	$16^{+0.018}_0$	6-M4 x 7L	2.2 (2.8)
04A□AHB01 (04A□AHB0C)	1/11	196.5 (236.5)	27	45	$25^{+0.021}_0$	6-M6 x 10L	3.8 (4.4)
04A□AHC01 (04A□AHC0C)	1/21						
04A□AH701 (04A□AH70C)	1/33	237.5 (277.5)	35	60	$40^{+0.025}_0$	6-M8 x 12L	7.4 (8.0)

Notes: 1 The models and values in parentheses are for servomotors with holding brakes.
2 Dimensions not found in the table above are the same as those in the table on the previous page.

(3) 750 W

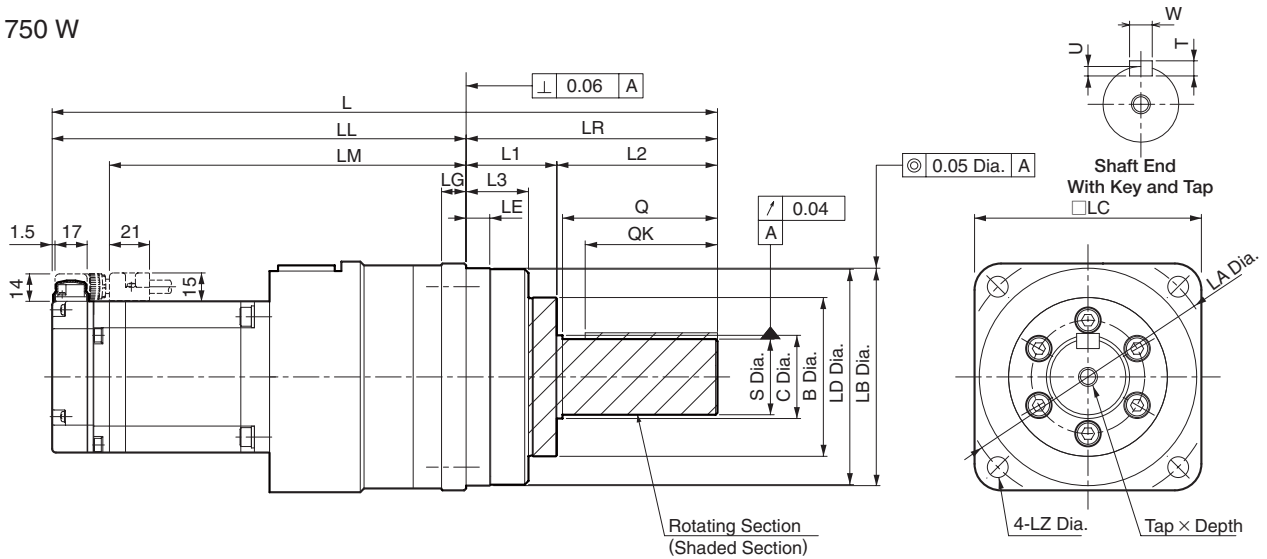

Model SGMJV-	Gear Ratio	L	LL	LM	Flange Face Dimensions								
					LR	LE	LG	B	LD	LB	LC	LA	LZ
08A□AH1※1 (08A□AH1※C)	1/5	273 (318)	193 (238)	163	80	7.5	10	59	84	85 ⁰ _{0.035}	90	105	9
08A□AHB※1 (08A□AHB※C)	1/11												
08A□AHC※1 (08A□AHC※C)	1/21	352 (397)	219 (264)	189	133	12.5	13	84	114	115 ⁰ _{0.035}	120	135	11
08A□AH7※1 (08A□AH7※C)	1/33												

Model SGMJV-	L1	L2	L3	Q	C	S (Shaft)	Tap×Depth	Key Dimensions				Approx. Mass kg
								QK	U	W	T	
08A□AH1※1 (08A□AH1※C)	36	44	26	42	32	25 ⁰ _{0.021}	M6×12L	36	4	8	7	5.6 (6.5)
08A□AHB※1 (08A□AHB※C)												5.8 (6.7)
08A□AHC※1 (08A□AHC※C)	48	85	33	82	44	40 ⁰ _{0.025}	M10×20L	70	5	12	8	10.5 (11.4)
08A□AH7※1 (08A□AH7※C)												

: The asterisk () describes the values of the 8th digit of the model designation, "shaft end code 6 (straight with key and tap)." If a key or tap is not necessary, order a servomotor with "shaft end code 2 (without key and tap)" or "shaft end code 8 (without key and with tap)."

Notes: 1 The models and values in parentheses are for servomotors with holding brakes.

2 Please note that gear dimensions are different from those of Σ-I, Σ-II, and Σ-III series.

With Low-backlash Gears

External Dimensions Units: mm

● Flange Output Face

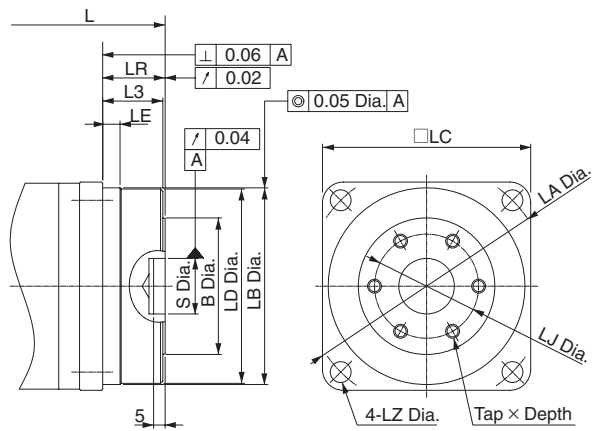

Model SGMJV-	Gear Ratio	L	LR	LJ	S (Hole)	Tap×Depth	Approx. Mass kg
08A□AH101 (A8A□AH10C)	1/5	220 (265)	27	45	$25^{+0.021}_0$	6-M6×10L	5.2 (6.1)
08A□AHB01 (A8A□AHB0C)	1/11						5.4 (6.3)
08A□AHC01 (A8A□AHC0C)	1/21	254 (299)	35	60	$40^{+0.025}_0$	6-M8×12L	9.1 (10.0)
08A□AH701 (A8A□AH70C)	1/33						

Notes: 1 The models and values in parentheses are for servomotors with holding brakes.
 2 Dimensions not found in the table above are the same as those in the table on the previous page.

Rotary Servomotors

SGMAV



Model Designations

• Without Gears

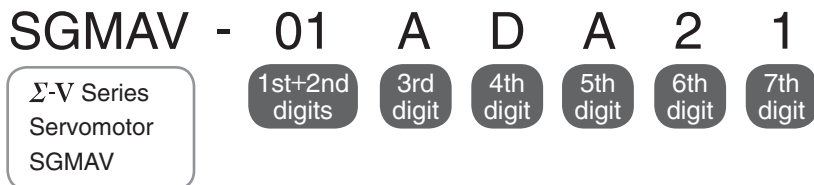

1st+2nd digits Rated Output

Code	Specifications
A5	50 W
01	100 W
C2	150 W
02	200 W
04	400 W
06	550 W
08	750 W

3rd digit Power Supply Voltage

Code	Specifications
A	200 VAC

4th digit Serial Encoder

Code	Specifications
3	20-bit absolute (standard)
D	20-bit incremental (standard)

5th digit Design Revision Order

Code	Specifications
A	Standard

6th digit Shaft End

Code	Specifications
2	Straight without key (standard)
6	Straight with key and tap (optional)
8	Straight without key and with tap (optional)
B	With two flat seats (optional)

7th digit Options

Code	Specifications
1	Without options
C	With holding brake (24 VDC)
E	With oil seal and holding brake (24 VDC)
S	With oil seal

Features

- Super high power rate (Extremely low inertia)
- Instantaneous peak torque (300% of rated torque)
- Mounted high-resolution serial encoder: 20 bits
- Maximum speed: 6,000 min⁻¹
- Wide selection: 50 to 750 W capacity, holding brake and gear options

Application Examples

- Semiconductor equipment
- Chip mounters
- PCB drilling stations
- Robots
- Material handling machines
- Food processing equipment

● With Gears



1st+2nd digits Rated Output

Code	Specifications
A5	50 W
01	100 W
C2	150 W
02	200 W
04	400 W
06	550 W
08	750 W

3rd digit Power Supply Voltage

Code	Specifications
A	200 VAC

4th digit Serial Encoder

Code	Specifications
3	20-bit absolute (standard)
D	20-bit incremental (standard)

5th digit Design Revision Order

Code	Specifications
A	Standard

6th digit Gear Type

Code	Specifications
H	HDS planetary low-backlash gear

7th digit Gear Ratio

Code	Specifications
B	1/11 (Not available: 50 W)
C	1/21
1	1/5
2	1/9 (Only 50 W)
7	1/33

8th digit Shaft End

Code	Specifications
0	Flange output
2	Straight without key
6	Straight with key and tap
8	Straight without key and with tap

9th digit Options

Code	Specifications
1	Without options
C	With holding brake (24 VDC)

Ratings and Specifications

Time Rating: Continuous
Vibration Class: V15
Insulation Resistance: 500 VDC, 10 MΩ min.
Ambient Temperature: 0 to 40°C
Excitation: Permanent magnet
Mounting: Flange method

Thermal Class: B
Withstand Voltage: 1500 VAC for one minute
Enclosure: Totally enclosed, self-cooled, IP65
 (except for shaft opening)
Ambient Humidity: 20% to 80% (no condensation)
Drive Method: Direct drive
Rotation Direction: Counterclockwise (CCW)

Voltage		200 V						
Servomotor Model: SGMAV-□□□		A5A	01A	C2A	02A	04A	06A	08A
Rated Output*1	W	50	100	150	200	400	550	750
Rated Torque*1, *2	N·m	0.159	0.318	0.477	0.637	1.27	1.75	2.39
Instantaneous Peak Torque*1	N·m	0.477	0.955	1.43	1.91	3.82	5.25	7.16
Rated Current*1	Arms	0.66	0.91	1.3	1.5	2.6	3.8	5.3
Instantaneous Max. Current*1	Arms	2.1	2.8	4.2	5.3	8.5	12.2	16.6
Rated Speed*1	min ⁻¹	3000						
Max. Speed*1	min ⁻¹	6000						
Torque Constant	N·m/Arms	0.265	0.375	0.381	0.450	0.539	0.496	0.487
Rotor Moment of Inertia	kg·m ² × 10 ⁻⁴	0.0242 (0.0312)	0.0380 (0.0450)	0.0531 (0.0601)	0.116 (0.180)	0.190 (0.254)	0.326 (0.390)	0.769 (0.940)
Rated Power Rate*1	kW/s	10.4	26.6	42.8	35.0	84.9	93.9	74.1
Rated Angular Acceleration*1	rad/s ²	65800	83800	89900	54900	67000	53700	31000
Applicable SERVOPACK	SGDV-□□□	R70	R90	1R6	1R6	2R8	5R5	5R5

*1: These items and torque-motor speed characteristics quoted in combination with an SGDV SERVOPACK are at an armature winding temperature of 100°C. Other values quoted are at 20°C.

*2: Rated torques are continuous allowable torque values at 40°C with an aluminum heat sink of the following dimensions attached.
 SGMAV-A5, -01: 200 mm×200 mm×6 mm
 SGMAV-C2, -02, -04, -06, -08: 250 mm×250 mm×6 mm

Note: The values in parentheses are for servomotors with holding brakes.

● Torque-Motor Speed Characteristics A: Continuous Duty Zone B: Intermittent Duty Zone

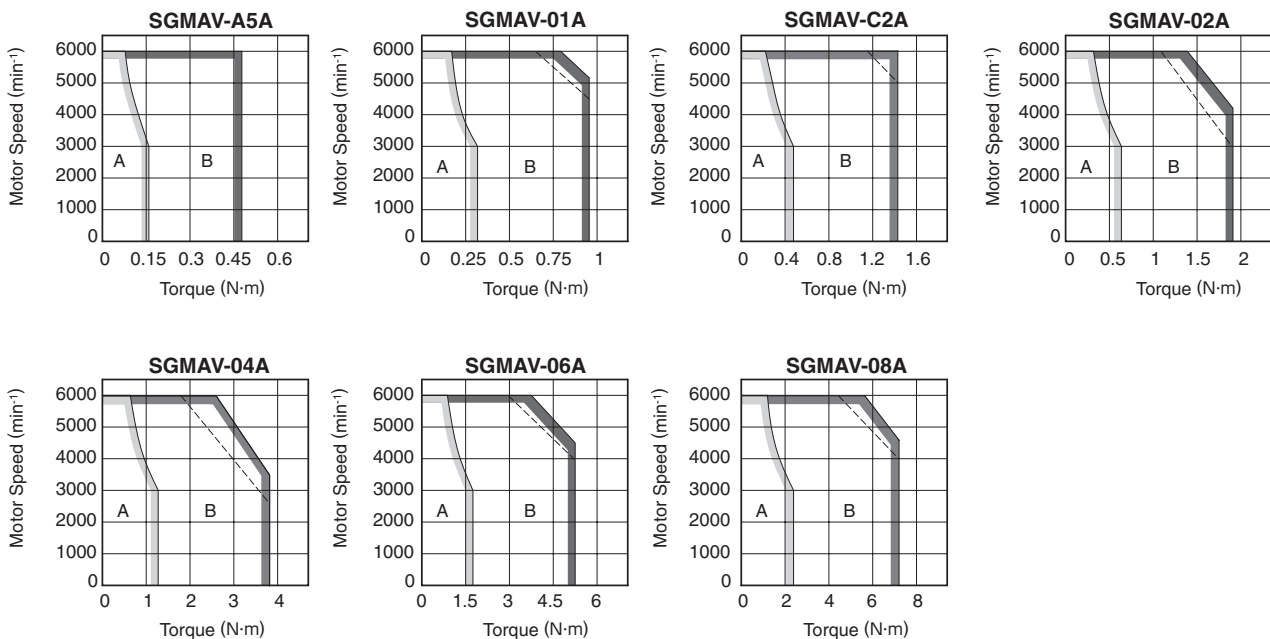

Notes: 1 The solid and dotted lines of the intermittent duty zone indicate the characteristics when a servomotor runs in the following combinations:

- The solid line: With a three-phase 200 V or a single-phase 230 V SERVOPACK
- The dotted line: With a single-phase 200 V SERVOPACK

An SGMAV-A5 servomotor has the same characteristics in combination with three-phase and single-phase SERVOPACKs.

2 The characteristics of the intermittent duty zone differ depending on the supply voltages.

Ratings and Specifications

● Derating Rate for Servomotor Fitted with an Oil Seal

When a motor is fitted with an oil seal, use the following derating rate because of the higher friction torque.

Servomotor Model SGMAV-	A5A	01A	C2A	02A	04A	06A	08A
Derating Rate %	80	90			95		

● Holding Brake Electrical Specifications

Holding Brake Rated Voltage	Servomotor Model	Servomotor Rated Output W	Holding Brake Specifications					
			Capacity W	Holding Torque N·m	Coil Resistance Ω (at 20°C)	Rated Current A(at 20°C)	Brake Release Time ms	Brake Operation Time ms
24 VDC ^{+10%} ₀	SGMAV-A5A	50	6	0.159	96	0.25	60	100
	SGMAV-01A	100	6	0.318	96	0.25	60	100
	SGMAV-C2A	150	6	0.477	96	0.25	60	100
	SGMAV-02A	200	6.9	0.637	83	0.29	60	100
	SGMAV-04A	400	6.9	1.27	83	0.29	60	100
	SGMAV-06A	550	8.7	1.75	67	0.36	80	100
	SGMAV-08A	750	7.7	2.39	75	0.32	80	100

Notes: 1 The holding brake is only used to hold the load and cannot be used to stop the servomotor.

2 The holding brake open time and holding brake operation time vary depending on which discharge circuit is used. Make sure holding brake open time and holding brake operation time are correct for your servomotor.

● Overload Characteristics

The overload detection level is set under hot start conditions at a servomotor ambient temperature of 40°C.

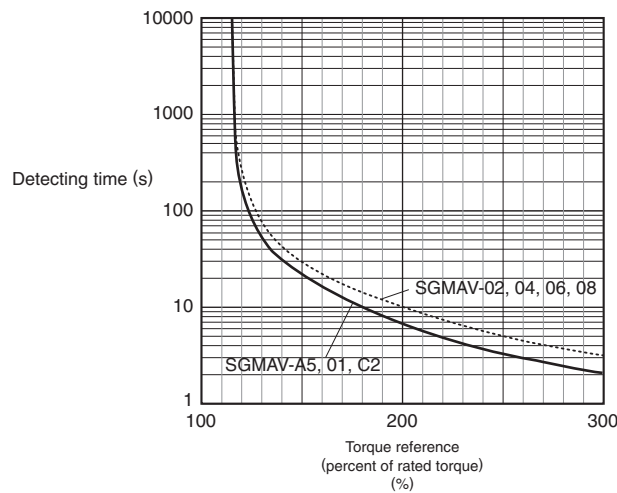

● Allowable Load Moment of Inertia at the Motor Shaft

The rotor moment of inertia ratio is the value for a servomotor without a gear and a brake.

Servomotor Model	Servomotor Rated Output	Allowable Load Moment of Inertia (Rotor Moment of Inertia Ratio)
SGMAV-	A5A, 01A, C2A, 02A	50 to 200 W
	04A, 06A, 08A	400 to 750 W

Ratings and Specifications

● Load Moment of Inertia

The larger the load moment of inertia, the worse the movement response of the load.

The size of the load moment of inertia (J_L) allowable when using a servomotor depends on motor capacity and is limited to within 5 to 30 times the rotor moment of inertia of each servomotor (J_M). This value is provided strictly as a guideline and results may vary depending on servomotor drive conditions.

An overvoltage alarm (A.400) is likely to occur during deceleration if the load moment of inertia exceeds the allowable load moment of inertia. SERVOPACKs with a built-in regenerative resistor may generate a regenerative overload alarm (A.320). Take one of the following steps if this occurs.

- Reduce the torque limit.
- Reduce the deceleration rate.
- Reduce the maximum speed.
- Install an external regenerative resistor if the alarm cannot be cleared. Contact your Yaskawa representative.

Regenerative resistors are not built into SGD-2R8 SERVOPACKs for 400 W motors or less. The following figures show the relationship between the load moment of inertia and motor speed using an example with a load moment of inertia 10 to 30 times the rotor moment of inertia at the motor shaft.

External regenerative resistors are required when this condition is exceeded or if the allowable loss capacity (W) of the built-in regenerative resistor is exceeded due to regenerative drive conditions when a regenerative resistor is already built in.

● Load Moment of Inertia and Motor Speed

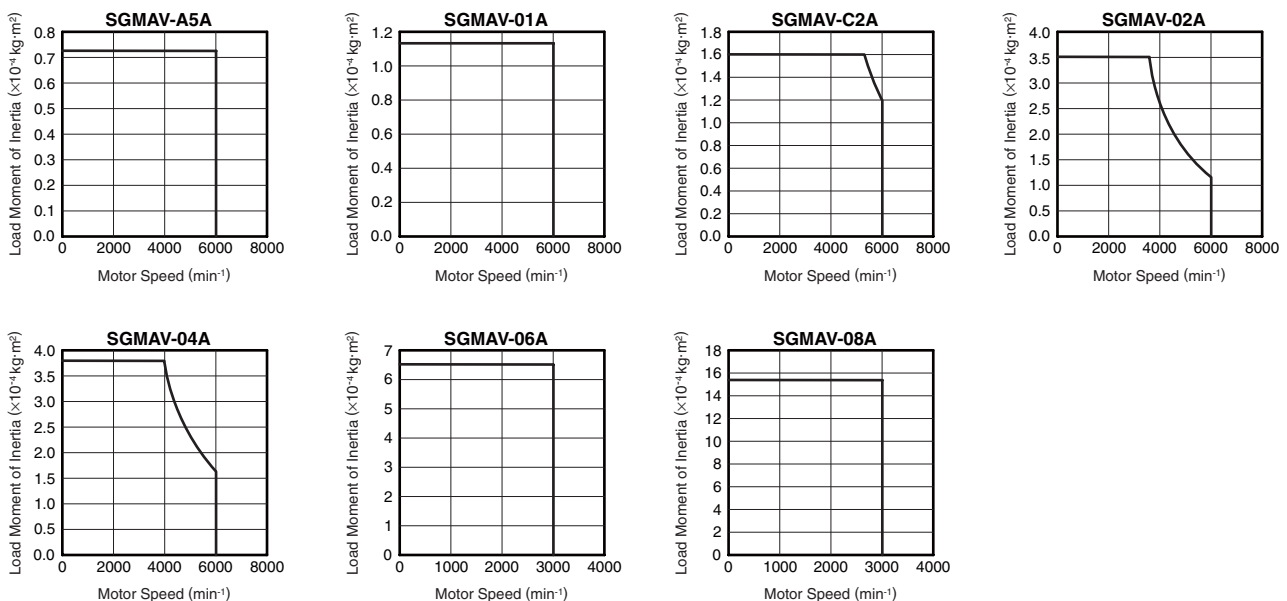

● Allowable Radial and Thrust Loads

Design the mechanical system so thrust and radial loads applied to the servomotor shaft end during operation fall within the ranges shown in the table.

Servomotor Model	Allowable Radial Load (Fr) N	Allowable Thrust Load (Fs) N	LR mm	Reference Diagram
SGMAV-	A5A	54	20	
	01A			
	C2A			
	02A	74	25	
	04A			
	06A			
	08A			

External Dimensions Units: mm

● Without Holding Brakes (With Holding Brakes)

(1) 50 to 150 W

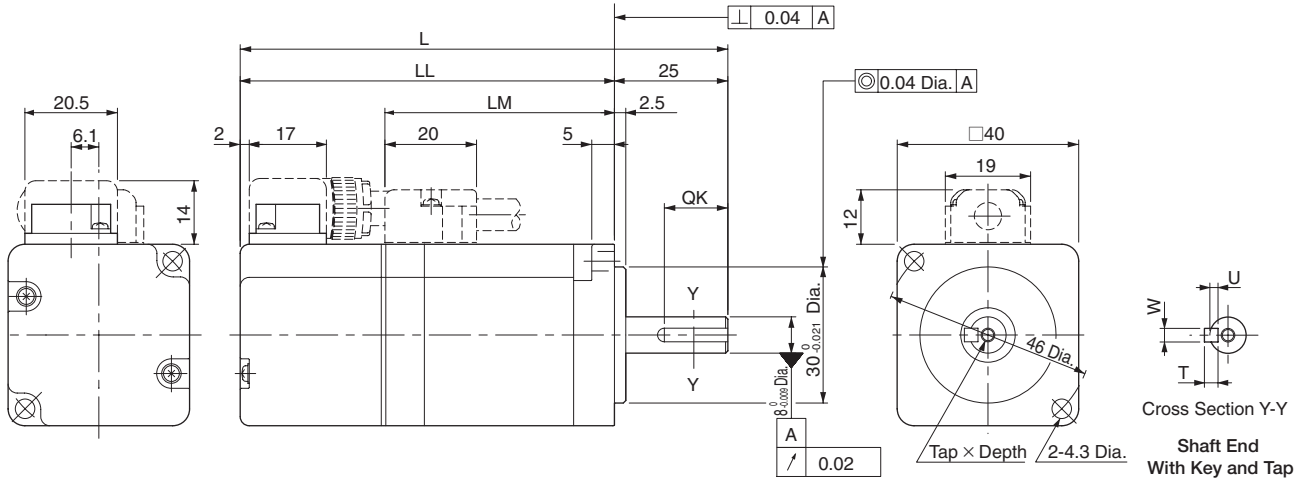

Model SGMAV-	L	LL	LM	Tap×Depth	Key Dimensions				Approx. Mass kg
					QK	U	W	T	
A5A□A21 (A5A□A2C)	95.5 (140.5)	70.5 (115.5)	38.5	No tap	No key				0.3 (0.6)
A5A□A61 (A5A□A6C)				M3×6L	14	1.8	3	3	
A5A□A81 (A5A□A8C)				No key					
01A□A21 (01A□A2C)	107.5 (152.5)	82.5 (127.5)	50.5	No tap	No key				0.4 (0.7)
01A□A61 (01A□A6C)				M3×6L	14	1.8	3	3	
01A□A81 (01A□A8C)				No key					
C2A□A21 (C2A□A2C)	119.5 (164.5)	94.5 (139.5)	62.5	No tap	No key				0.5 (0.8)
C2A□A61 (C2A□A6C)				M3×6L	14	1.8	3	3	
C2A□A81 (C2A□A8C)				No key					

Note: The models and values in parentheses are for servomotors with holding brakes.

〈Shaft End and Other Options〉

● With Two Flat Seats

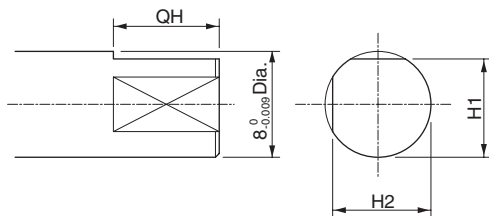

Model SGMAV-	Dimensions of Servomotor with Two Flat Seats		
	QH	H1	H2
A5A□AB1 (A5A□ABC)	14	7.5	7.5
01A□AB1 (01A□ABC)			
C2A□AB1 (C2A□ABC)			

Note: The models in parentheses are for servomotors with holding brakes.

● With an Oil Seal

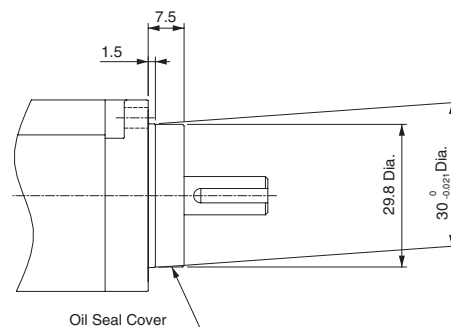

Note: The 7th digit of the model designation is "S" or "E." The key dimensions are the same as those in the table above.

External Dimensions Units: mm

(2) 200 to 750 W

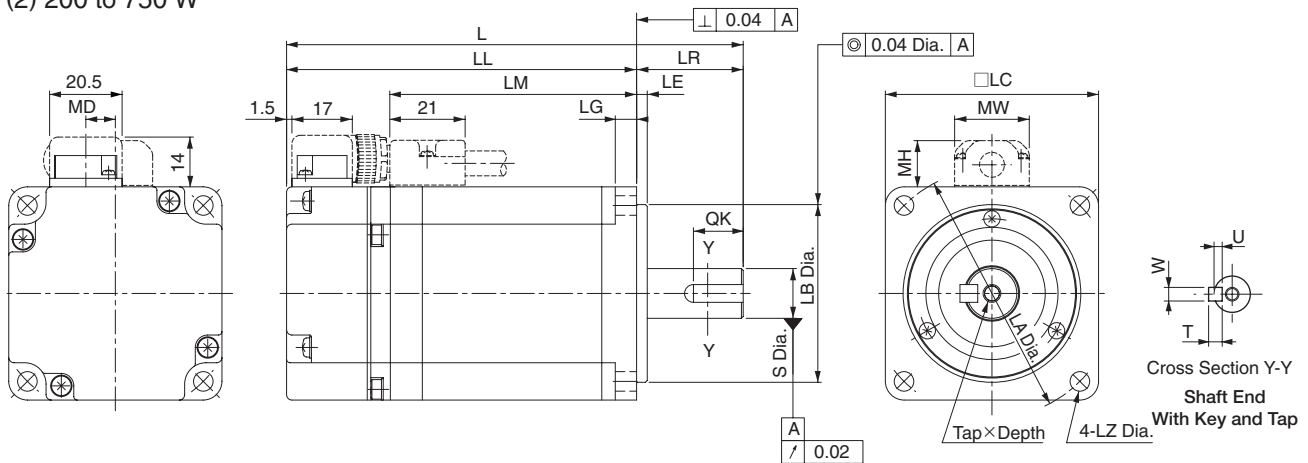

Model SGMAV-	L	LL	LM	Flange Face Dimensions								S	Tap x Depth	Key Dimensions				MD	MW	MH	Approx. Mass kg
				LR	LE	LG	LC	LA	LB	LZ	QK			U	W	T					
02A□A21 (02A□A2C)	110 (150)	80 (120)	51	30	3	6	60	70	50 ⁰ _{0.025}	5.5	14 ⁰ _{0.011}	No tap	No key				8.5	21	13	0.9 (1.5)	
M5×8L												20	3	5	5						
No key																					
04A□A21 (04A□A2C)	128.5 (168.5)	98.5 (138.5)	69.5	30	3	6	60	70	50 ⁰ _{0.025}	5.5	14 ⁰ _{0.011}	No tap	No key				8.5	21	13	1.2 (1.8)	
M5×8L												14	3	5	5						
No key																					
06A□A21 (06A□A2C)	154.5 (200.5)	124.5 (170.5)	95.5	30	3	6	60	70	50 ⁰ _{0.025}	5.5	14 ⁰ _{0.011}	No tap	No key				8.5	21	13	1.7 (2.4)	
M5×8L												14	3	5	5						
No key																					
08A□A21 (08A□A2C)	155 (200)	115 (160)	85	40	3	8	80	90	70 ⁰ _{0.030}	7	19 ⁰ _{0.013}	No tap	No key				13.8	27	15	2.3 (3.2)	
M6×10L												22	3.5	6	6						
No key																					

Note: The models and values in parentheses are for servomotors with holding brakes.

<Shaft End and Other Options>

● With Two Flat Seats

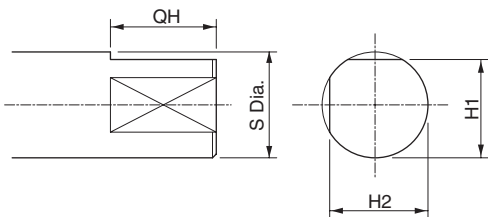

Model SGMAV-	Dimensions of Servomotor with Two Flat Seats			
	QH	S	H1	H2
02A□AB1 (02A□ABC)	14	14 ⁰ _{0.011}	13	13
04A□AB1 (04A□ABC)				
06A□AB1 (06A□ABC)				
08A□AB1 (08A□ABC)	22	19 ⁰ _{0.013}	18	18

Note: The models in parentheses are for servomotors with holding brakes.

● With an Oil Seal

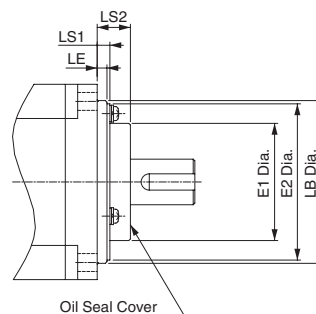

Model SGMAV-	Dimensions of Servomotor with an Oil Seal mm			
	E1	E2	LS1	LS2
02, 04, 06	36	48	4	10
08	49	66	6	11

Note: The 7th digit of the model designation is "S" or "E."
The key dimensions are the same as those in the table above.

Selecting Cables

● Cables Connections

- Standard Wiring (Max. encoder cable length: 20 m)
- Encoder Cable Extension from 30 to 50 m

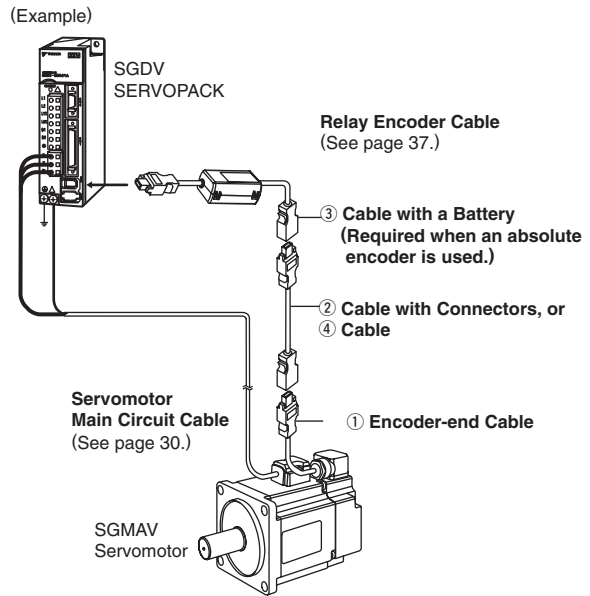
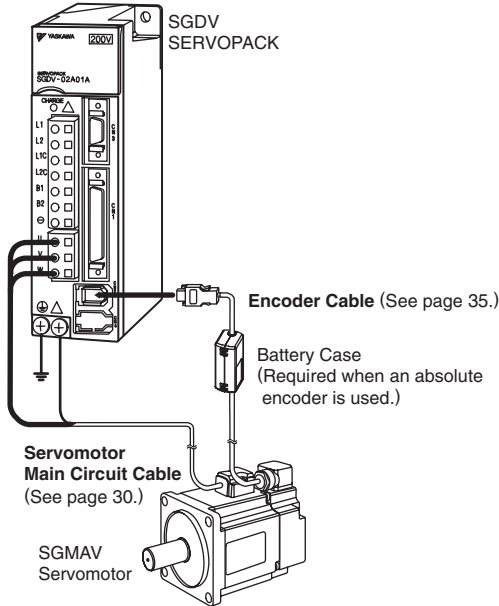

⚠ CAUTION

Separate the servomotor main circuit wiring from the signal line and encoder (PG) feedback line at least 30 cm, and do not bundle or run them in the same duct.



● Servomotor Main Circuit Cable

Contact Yaskawa Controls. Co., Ltd.

Name	Servomotor Rated Output	Length	Order No.		Specifications	Details
			Standard Type	Flexible Type*		
For Servomotor without Holding Brakes	50 to 150 W	3 m	JZSP-CSM01-03-E	JZSP-CSM21-03-E		(1)
		5 m	JZSP-CSM01-05-E	JZSP-CSM21-05-E		
		10 m	JZSP-CSM01-10-E	JZSP-CSM21-10-E		
		15 m	JZSP-CSM01-15-E	JZSP-CSM21-15-E		
		20 m	JZSP-CSM01-20-E	JZSP-CSM21-20-E		
		30 m	JZSP-CSM01-30-E	JZSP-CSM21-30-E		
		40 m	JZSP-CSM01-40-E	JZSP-CSM21-40-E		
	50 m	JZSP-CSM01-50-E	JZSP-CSM21-50-E			
	200 to 550 W	3 m	JZSP-CSM02-03-E	JZSP-CSM22-03-E		
		5 m	JZSP-CSM02-05-E	JZSP-CSM22-05-E		
		10 m	JZSP-CSM02-10-E	JZSP-CSM22-10-E		
		15 m	JZSP-CSM02-15-E	JZSP-CSM22-15-E		
		20 m	JZSP-CSM02-20-E	JZSP-CSM22-20-E		
		30 m	JZSP-CSM02-30-E	JZSP-CSM22-30-E		
		40 m	JZSP-CSM02-40-E	JZSP-CSM22-40-E		
	50 m	JZSP-CSM02-50-E	JZSP-CSM22-50-E			
	750 W	3 m	JZSP-CSM03-03-E	JZSP-CSM23-03-E		
		5 m	JZSP-CSM03-05-E	JZSP-CSM23-05-E		
		10 m	JZSP-CSM03-10-E	JZSP-CSM23-10-E		
		15 m	JZSP-CSM03-15-E	JZSP-CSM23-15-E		
		20 m	JZSP-CSM03-20-E	JZSP-CSM23-20-E		
		30 m	JZSP-CSM03-30-E	JZSP-CSM23-30-E		
		40 m	JZSP-CSM03-40-E	JZSP-CSM23-40-E		
	50 m	JZSP-CSM03-50-E	JZSP-CSM23-50-E			

(Cont'd)

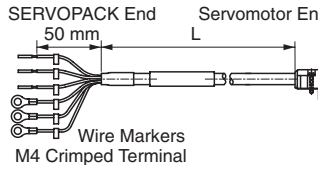
Selecting Cables

Name	Servomotor Rated Output	Length	Order No.		Specifications	Details
			Standard Type	Flexible Type*		
For Servomotor with Holding Brakes	50 to 150 W	3 m	JZSP-CSM11-03-E	JZSP-CSM31-03-E		(2)
		5 m	JZSP-CSM11-05-E	JZSP-CSM31-05-E		
		10 m	JZSP-CSM11-10-E	JZSP-CSM31-10-E		
		15 m	JZSP-CSM11-15-E	JZSP-CSM31-15-E		
		20 m	JZSP-CSM11-20-E	JZSP-CSM31-20-E		
		30 m	JZSP-CSM11-30-E	JZSP-CSM31-30-E		
		40 m	JZSP-CSM11-40-E	JZSP-CSM31-40-E		
	200 to 550 W	3 m	JZSP-CSM12-03-E	JZSP-CSM32-03-E		
		5 m	JZSP-CSM12-05-E	JZSP-CSM32-05-E		
		10 m	JZSP-CSM12-10-E	JZSP-CSM32-10-E		
		15 m	JZSP-CSM12-15-E	JZSP-CSM32-15-E		
		20 m	JZSP-CSM12-20-E	JZSP-CSM32-20-E		
		30 m	JZSP-CSM12-30-E	JZSP-CSM32-30-E		
		40 m	JZSP-CSM12-40-E	JZSP-CSM32-40-E		
	750 W	3 m	JZSP-CSM13-03-E	JZSP-CSM33-03-E		
		5 m	JZSP-CSM13-05-E	JZSP-CSM33-05-E		
		10 m	JZSP-CSM13-10-E	JZSP-CSM33-10-E		
		15 m	JZSP-CSM13-15-E	JZSP-CSM33-15-E		
		20 m	JZSP-CSM13-20-E	JZSP-CSM33-20-E		
		30 m	JZSP-CSM13-30-E	JZSP-CSM33-30-E		
		40 m	JZSP-CSM13-40-E	JZSP-CSM33-40-E		
Servomotor-end Connector Kit	50 to 150 W	JZSP-CSM9-1-E		Crimping Type (A crimp tool is required.) 	(3)	
	200 to 550 W	JZSP-CSM9-2-E			(4)	
	750 W	JZSP-CSM9-3-E			(5)	
Cables	50 to 550 W	5 m	JZSP-CSM90-05-E	JZSP-CSM80-05-E		(6)
		10 m	JZSP-CSM90-10-E	JZSP-CSM80-10-E		
		15 m	JZSP-CSM90-15-E	JZSP-CSM80-15-E		
		20 m	JZSP-CSM90-20-E	JZSP-CSM80-20-E		
		30 m	JZSP-CSM90-30-E	JZSP-CSM80-30-E		
		40 m	JZSP-CSM90-40-E	JZSP-CSM80-40-E		
		50 m	JZSP-CSM90-50-E	JZSP-CSM80-50-E		
	750 W	5 m	JZSP-CSM91-05-E	JZSP-CSM81-05-E		(7)
		10 m	JZSP-CSM91-10-E	JZSP-CSM81-10-E		
		15 m	JZSP-CSM91-15-E	JZSP-CSM81-15-E		
		20 m	JZSP-CSM91-20-E	JZSP-CSM81-20-E		
		30 m	JZSP-CSM91-30-E	JZSP-CSM81-30-E		
		40 m	JZSP-CSM91-40-E	JZSP-CSM81-40-E		
		50 m	JZSP-CSM91-50-E	JZSP-CSM81-50-E		

*: Use flexible cables for movable sections such as robot arms.

Selecting Cables

(1) Wiring Specifications for Servomotors without Holding Brakes (2) Wiring Specifications for Servomotor with Holding Brakes

SERVOPACK-end Leads		Servomotor-end Connector	
Wire Color	Signal	Signal	Pin No.
Green/yellow	FG	FG	1
Blue	Phase W	Phase W	2
White	Phase V	Phase V	3
Red	Phase U	Phase U	4
		-	5
		-	6

SERVOPACK-end Leads		Servomotor-end Connector	
Wire Color	Signal	Signal	Pin No.
Green/yellow	FG	FG	1
Blue	Phase W	Phase W	2
White	Phase V	Phase V	3
Red	Phase U	Phase U	4
Black	Brake	Brake	5
Black	Brake	Brake	6

Note: No polarity for connection to a holding brake.

(3) Servomotor-end Connector Kit Specifications: For 50 to 150 W Servomotors

Items	Specifications	External Dimensions mm
Order No.	JZSP-CSM9-1-E (Cables are not included.)	
Applicable Servomotors	SGMAV-A5, -01, -C2	
Manufacturer	J.S.T. Mfg. Co., Ltd.	
Receptacle	J17-06FMH-7KL-1-CF	
Electrical Contact	SJ1F-01GF-P0.8	
Applicable Wire Size	AWG20 to 24	
Outer Diameter of Insulating Sheath	1.11 dia. to 1.53 dia. mm	
Crimp Tool	Hand tool: YRS-8841 Applicator: APLMK SJIF/M-01-08	
Mounting Screw	M2 Pan-head screw	
Applicable Cable Outer Diameter	7±0.3 dia. mm	

Selecting Cables

(4) Servomotor-end Connector Kit Specifications: For 200 to 550 W Servomotors

Items	Specifications	External Dimensions mm	
Order No.	JZSP-CSM9-2-E (Cables are not included.)		
Applicable Servomotors	SGMAV-02, -04, -06		
Manufacturer	J.S.T. Mfg. Co., Ltd.		
Receptacle	J27-06FMH-7KL-1-CF		
Electrical Contact	SJ2F-01GF-P1.0		
Applicable Wire Size	AWG20 to 24		
Outer Diameter of Insulating Sheath	1.11 dia. to 1.53 dia. mm		
Crimp Tool	Hand tool		YRS-8861
	Applicator		APLMK SJ2F/M-01-08
Mounting Screw	M2 Pan-head screw		
Applicable Cable Outer Diameter	7±0.3 dia. mm		

(5) Servomotor-end Connector Kit Specifications: For 750 W Servomotors

Items	Specifications	External Dimensions mm		
Order No.	JZSP-CSM9-3-E (Cables are not included.)			
Applicable Servomotors	SGMAV-08			
Manufacturer	J.S.T. Mfg. Co., Ltd.			
Receptacle	J37-06FMH-8KL-1-CF			
Cable Type	Standard			
Electrical Contact	SJ3F-41GF-P1.8 (For power terminals)		SJ3F-01GF-P1.8 (For holding brake terminals)	
	Applicable Wire Size		AWG16 to 20	AWG20 to 24
Outer Diameter of Insulating Sheath	1.53 dia. to 2.5 dia. mm		1.11 dia. to 1.86 dia. mm	
Crimp Tool	Hand tool		YRF-880	YRF-881
	Applicator		APLMK SF3F/M-41-20	APLMK SF3F/M-01-20
Mounting Screw	M2.5 Pan-head screw			
Applicable Cable Outer Diameter	8±0.3 dia. mm			

Selecting Cables

(6) Cable Specifications: For 50 to 550 W Servomotors

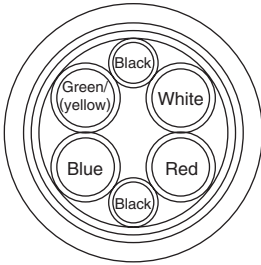
Items	Standard Type	Flexible Type
Order No.*	JZSP-CSM90-□□-E (50 m max.)	JZSP-CSM80-□□-E (50 m max.)
Specifications	UL2517 (Max. operating temperature: 105°C) AWG20×6C For power line: AWG20 (0.52 mm ²) Outer diameter of insulating sheath: 1.53 dia. mm For holding brake line: AWG20 (0.52 mm ²) Outer diameter of insulating sheath: 1.53 dia. mm	UL2517 (Max. operating temperature: 105°C) AWG22×6C For power line: AWG22 (0.33 mm ²) Outer diameter of insulating sheath: 1.37 dia. mm For holding brake line: AWG22 (0.33 mm ²) Outer diameter of insulating sheath: 1.37 dia. mm
Finished Dimensions	7±0.3 dia. mm	
Internal Configuration and Lead Color		
Yaskawa Standard Specifications (Standard Length)	Cable length: 5 m, 10 m, 15 m, 20 m, 30 m, 40 m, 50 m	

*: Specify the cable length in □□ of order no.
Example: JZSP-CSM90-05-E (5 m)

(7) Cable Specifications: For 750 W Servomotors

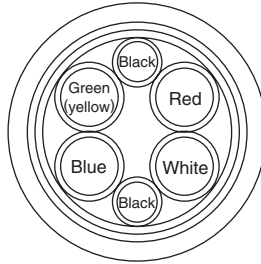
Items	Standard Type	Flexible Type
Order No.*	JZSP-CSM91-□□-E (50 m max.)	JZSP-CSM81-□□-E (50 m max.)
Specifications	UL2517 (Max. operating temperature: 105°C) AWG16×4C, AWG20×2C For power line: AWG16 (1.31 mm ²) Outer diameter of insulating sheath: 2.15 dia. mm For holding brake line: AWG20 (0.52 mm ²) Outer diameter of insulating sheath: 1.6 dia. mm	UL2517 (Max. operating temperature: 105°C) AWG16×4C, AWG22×2C For power line: AWG16 (1.31 mm ²) Outer diameter of insulating sheath: 2.35 dia. mm For holding brake line: AWG22 (0.33 mm ²) Outer diameter of insulating sheath: 1.37 dia. mm
Finished Dimensions	8±0.3 dia. mm	
Internal Configuration and Lead Color		
Yaskawa Standard Specifications (Standard Length)	Cable length: 5 m, 10 m, 15 m, 20 m, 30 m, 40 m, 50 m	

*: Specify the cable length in □□ of order no.
Example: JZSP-CSM91-15-E (15 m)

Selecting Cables

Encoder Cables (Length: 20 m or less)

Contact Yaskawa Controls Co., Ltd.

Name	Length	Order No.		Specifications	Details
		Standard Type	Flexible Type*		
Cable with Connectors (For Incremental Encoder)	3 m	JZSP-CSP01-03-E	JZSP-CSP21-03-E		(1)
	5 m	JZSP-CSP01-05-E	JZSP-CSP21-05-E		
	10 m	JZSP-CSP01-10-E	JZSP-CSP21-10-E		
	15 m	JZSP-CSP01-15-E	JZSP-CSP21-15-E		
	20 m	JZSP-CSP01-20-E	JZSP-CSP21-20-E		
Cable with Connectors (For Absolute Encoder, with a Battery Case)	3 m	JZSP-CSP05-03-E	JZSP-CSP25-03-E		(2)
	5 m	JZSP-CSP05-05-E	JZSP-CSP25-05-E		
	10 m	JZSP-CSP05-10-E	JZSP-CSP25-10-E		
	15 m	JZSP-CSP05-15-E	JZSP-CSP25-15-E		
	20 m	JZSP-CSP05-20-E	JZSP-CSP25-20-E		
SERVOPACK-end Connector Kit		JZSP-CMP9-1-E		Soldered 	(3)
Encoder-end Connector Kit		JZSP-CSP9-2-E		Crimping Type (A crimp tool is required.) 	
Cables	3 m	JZSP-CMP09-03-E	JZSP-CSP39-03-E		(4)
	5 m	JZSP-CMP09-05-E	JZSP-CSP39-05-E		
	10 m	JZSP-CMP09-10-E	JZSP-CSP39-10-E		
	15 m	JZSP-CMP09-15-E	JZSP-CSP39-15-E		
	20 m	JZSP-CMP09-20-E	JZSP-CSP39-20-E		

*: Use flexible cables for movable sections such as robot arms.

Note: When the battery from the host controller is used for the absolute encoder, no battery case is required. In this case, use a cable for the incremental encoders.

(1) Wiring Specifications for Cable with Connectors (For incremental encoder)

Standard Type

SERVOPACK End		Encoder (Servomotor) End	
Pin No.	Signal	Pin No.	Wire Color
6	/PS	5	Light blue/white
5	PS	4	Light blue
4	BAT (-)	8	White/orange
3	BAT (+)	9	Orange
2	PG 0V	3	Black
1	PG 5V	6	Red
Shell	FG	Shell	FG

Shield Wire

Flexible Type

SERVOPACK End		Encoder (Servomotor) End	
Pin No.	Signal	Pin No.	Wire Color
6	/PS	5	Black/pink
5	PS	4	Red/pink
4	BAT (-)	8	Black/light blue
3	BAT (+)	9	Red/light blue
2	PG 0V	3	Green
1	PG 5V	6	Orange
Shell	FG	Shell	FG

Shield Wire

(2) Wiring Specifications for Cable with Connectors (For absolute encoder, with a battery case)

Standard Type

SERVOPACK End		Encoder (Servomotor) End	
Pin No.	Signal	Pin No.	Wire Color
6	/PS	5	Light blue/white
5	PS	4	Light blue
4	BAT (-)	8	White/orange
3	BAT (+)	9	Orange
2	PG 0V	3	Black
1	PG 5V	6	Red
Shell	FG	Shell	FG

Shield Wire

Battery Case	
Pin No.	Signal
2	BAT (-)
1	BAT (+)

Flexible Type

SERVOPACK End		Encoder (Servomotor) End	
Pin No.	Signal	Pin No.	Wire Color
6	/PS	5	Black/pink
5	PS	4	Red/pink
4	BAT (-)	8	Black/light blue
3	BAT (+)	9	Red/light blue
2	PG 0V	3	Green
1	PG 5V	6	Orange
Shell	FG	Shell	FG

Shield Wire

Battery Case	
Pin No.	Signal
2	BAT (-)
1	BAT (+)

Selecting Cables

(3) SERVOPACK-end/Encoder-end Connector Kit Specifications

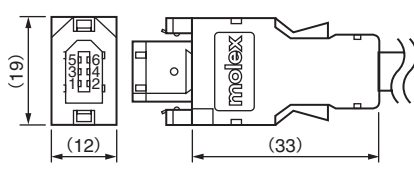
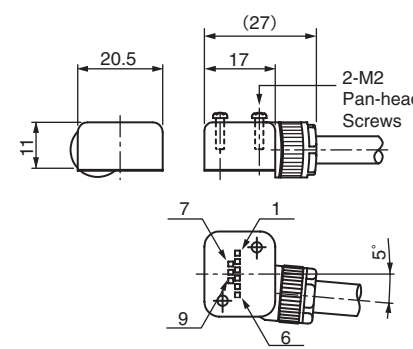
Items	SERVOPACK-end Connector Kit	Encoder-end Connector Kit
Order No.	JZSP-CMP9-1-E (Cables are not included.)	JZSP-CSP9-2-E (Cables are not included.)
Manufacturer	Molex Japan Co., Ltd.	Molex Japan Co., Ltd.
Specifications	55100-0670 (soldered)	54346-0070 (crimped)* Mounting screw: M2 pan-head screw (×2) Outer diameter of applicable cable: 6.3 dia. to 7.7 dia. mm Applicable wire size: AWG22 to 26 Outer diameter of insulating sheath: 1.05 dia. to 1.4 dia. mm
External Dimensions mm		

*: A crimp tool is required.
The following crimp tools are applicable for the cables provided by Yaskawa. When using other wire sizes, contact the respective manufacturer for crimp tools.
Applicable crimp tool for Yaskawa's wire size: Hand Tool Model No. 57175-5000
Applicator Model No. 57175-3000

(4) Cable Specifications

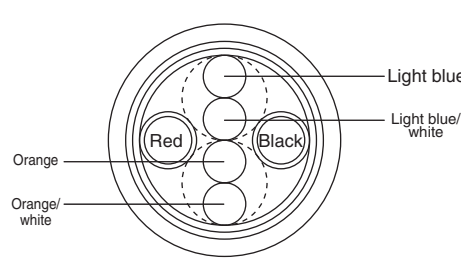
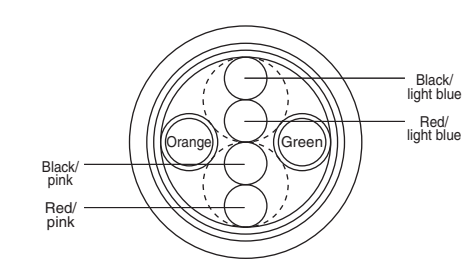
Items	Standard Type	Flexible Type
Order No.*	JZSP-CMP09-□□-E	JZSP-CSP39-□□-E
Cable Length	20 m max.	
Specifications	UL20276 (Max. operating temperature: 80°C) AWG22×2C+AWG24×2P AWG22 (0.33 mm ²) Outer diameter of insulating sheath: 1.15 dia. mm AWG24 (0.20 mm ²) Outer diameter of insulating sheath: 1.09 dia. mm	UL20276 (Max. operating temperature: 80°C) AWG22×2C+AWG24×2P AWG22 (0.33 mm ²) Outer diameter of insulating sheath: 1.35 dia. mm AWG24 (0.20 mm ²) Outer diameter of insulating sheath: 1.21 dia. mm
Finished Dimensions	6.5 dia. mm	6.8 dia. mm
Internal Configuration and Lead Color		
Yaskawa Standards Specifications (Standard Length)	Cable length: 5 m, 10 m, 15 m, 20 m	

*: Specify the cable length in □□ of order no.
Example: JZSP-CSM09-05-E (5 m)

Selecting Cables

● Relay Encoder Cables (For extending from 30 to 50 m)

Contact Yaskawa Controls Co., Ltd.

Name	Length	Order No. Standard Type	Specifications	Details
① Encoder-end Cables (For incremental and absolute encoder)	0.3 m	JZSP-UCSP11-E	<p>SERVOPACK End 0.3 m Encoder End</p> <p>Plug Connector (Crimped) Connector (Molex Japan Co., Ltd.) (Molex Japan Co., Ltd.)</p>	(1)
② Cable with Connectors (For incremental and absolute encoder)	30 m	JZSP-UCMP00-30-E	<p>SERVOPACK End L Encoder End</p> <p>Plug Connector (Crimped) Socket Connector (Soldered) (Molex Japan Co., Ltd.) (Molex Japan Co., Ltd.)</p>	(2)
	40 m	JZSP-UCMP00-40-E		
	50 m	JZSP-UCMP00-50-E		
③ Cable with a Battery Case (For absolute encoder)	0.3 m	JZSP-CSP12-E*	<p>SERVOPACK End 0.3 m Encoder End</p> <p>Plug Connector (Crimped) Socket Connector (Soldered) (Molex Japan Co., Ltd.) (Molex Japan Co., Ltd.)</p>	(3)
④ Cables	30 m	JZSP-CMP19-30-E		(4)
	40 m	JZSP-CMP19-40-E		
	50 m	JZSP-CMP19-50-E		

* : When using an incremental encoder or using an absolute encoder with a battery connected to the host controller, no battery case is required.

(1) Wiring Specifications for Encoder-end Cable

SERVOPACK End		Encoder (Servomotor) End	
Pin No.	Signal	Pin No.	Wire Color
6	/PS	5	Light blue/white
5	PS	4	Light blue
4	BAT (-)	8	White/orange
3	BAT (+)	9	Orange
2	PG 0V	3	Black
1	PG 5V	6	Red
Shell	FG	Shell	FG

Shield Wire

(2) Wiring Specifications for Cable with Connectors

SERVOPACK End		Encoder (Servomotor) End	
Pin No.	Signal	Pin No.	Wire Color
6	/PS	6	Light blue/white
5	PS	5	Light blue
4	BAT (-)	4	White/orange
3	BAT (+)	3	Orange
2	PG 0V	2	Black
1	PG 5V	1	Red
Shell	FG	Shell	FG

Shield Wire

Selecting Cables

(3) Wiring Specifications for Cable with a Battery Case

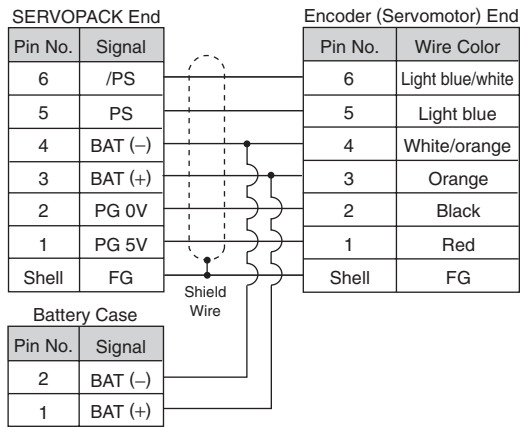

(4) Relay Encoder Cable Specifications

Item	Standard Type
Order No.*	JZSP-CMP19-□□-E
Cable Length	50 m max.
Specifications	UL20276 (Max. operating temperature: 80°C) AWG16×2C+AWG26×2P AWG16 (1.31 mm ²) Outer diameter of insulating sheath: 2.0 dia. mm AWG26 (0.13 mm ²) Outer diameter of insulating sheath: 0.91 dia. mm
Finished Dimensions	6.8 dia. mm
Internal Configuration and Lead Colors	
Yaskawa Standard Specifications (Standard Length)	Cable length: 30 m, 40 m, 50 m

*: Specify the cable length in □□ of order no.
Example: JZSP-CMP19-30-E (30 m)

With Low-backlash Gears

Ratings and Specifications

Time Rating: Continuous
Insulation Resistance: 500 VDC, 10 MΩ min.
Ambient Temperature: 0 to 40°C
Excitation: Permanent magnet
Mounting: Flange method
Gear Mechanism: Planetary gear mechanism
Thermal Class: B

Withstand Voltage: 1500 VAC for one minute
Enclosure: Totally enclosed, self-cooled, IP55
 (except for shaft opening)
Ambient Humidity: 20% to 80% (no condensation)
Drive Method: Direct drive
Rotation Direction: Counterclockwise (CCW)

Servomotor Model SGMAV-	Servomotor					Gear								
	Rated Output W	Rated Speed min ⁻¹	Max. Speed min ⁻¹	Rated Torque N·m	Instantaneous Peak Torque N·m	Gear Ratio	Lost Motion arc-min	Rated Torque / Efficiency*1 N·m /%	Instantaneous Peak Torque N·m	Rated Speed min ⁻¹	Max. Speed min ⁻¹			
A5A□AH1□	50	3000	6000	0.159	0.477	1/5	3 max.	0.557/70	2.10	600	1200			
A5A□AH2□						1/9		1.15/80				3.80	333	667
A5A□AHC□						1/21		2.67/80				9.00	143	286
A5A□AH7□						1/33		3.68/70				13.3	91	182
01A□AH1□	100	3000	6000	0.318	0.955	1/5	3 max.	1.35/85	4.30	600	1200			
01A□AHB□						1/11		2.45/70				9.00	273	545
01A□AHC□						1/21		5.35/80				17.6	143	286
01A□AH7□						1/33		7.35/70				27.7	91	182
C2A□AH1□	150	3000	6000	0.477	1.43	1/5	3 max.	2.03/85	6.50	600	1200			
C2A□AHB□						1/11		4.20/80				13.9	273	545
C2A□AHC□						1/21		7.02/70				26.2	143	286
C2A□AH7□						1/33		12.6/80				42.7	91	182
02A□AH1□	200	3000	6000	0.637	1.91	1/5	3 max.	2.39/75	8.30	600	1200			
02A□AHB□						1/11		5.60/80				18.8	273	545
02A□AHC□						1/21		10.0/75				35.9	143	286
02A□AH7□						1/33		16.8/80				57.3	91	182
04A□AH1□	400	3000	6000	1.27	3.82	1/5	3 max.	5.41/85	17.2	600	1200			
04A□AHB□						1/11		11.2/80				38.2	273	545
04A□AHC□						1/21		22.7/85				74.2	143	286
04A□AH7□						1/33		33.6/80				115	91	182
06A□AH1□	550	3000	6000	1.75	5.25	1/5	3 max.	7.00/80	23.6	600	1200			
06A□AHB□						1/11		16.4/85				53.4	273	545
06A□AHC□						1/21		29.4/80				100	143	286
06A□AHH□						1/33		49.1/85				161	91	182
08A□AH1□	750	3000	6000	2.39	7.16	1/5	3 max.	10.2/85	32.8	600	1200			
08A□AHB□						1/11		23.6/90				73.6	273	545
08A□AHC□						1/21		42.6/85				138	143	286
08A□AH7□						1/33		70.9/90				220	91	182

*1: Gear output torque is expressed using the following equation.

$$(\text{Gear output torque}) = (\text{Servomotor output torque}) \times \frac{1}{(\text{gear ratio})} \times (\text{efficiency})$$

*2: Peak torque is 300%

Note: The no-load torque for a servomotor with a gear is high immediately after the servomotor starts, and it then decreases and becomes stable a few minutes later. This is a common phenomenon caused by grease being circulated in the gear and not by a faulty gear.

IMPORTANT The SERVOPACK speed control range is 5000:1. When using servomotors at extremely low speeds (0.02 min⁻¹ at gear output shaft), or when using servomotors with 1 pulse feed reference for extended periods etc., the gear bearing lubrication may be insufficient. That may cause deterioration of bearing or increase the load ratio. Contact your Yaskawa representative if you are using your servomotor under these conditions.

With Low-backlash Gears Ratings and Specifications

● **Moment of Inertia and Allowable Radial and Thrust Loads**

Servomotor Model SGMAV-	Moment of Inertia × 10 ⁻⁴ kg·m ²				Servomotors with Low-backlash Gears			Reference Diagram
	Motor + Gear	Gear	Flange Output		Allowable Radial Load (Fr) N	Allowable Thrust Load (Fs) N	LR mm	
			Motor + Gear	Gear				
A5A□AH1□	0.0302	0.006	0.0292	0.005	95	431	37	
A5A□AH2□	0.0272	0.003	0.0272	0.003	113	514	37	
A5A□AHC□	0.0282	0.004	0.0282	0.004	146	663	37	
A5A□AH7□	0.0692	0.045	0.0692	0.045	267	1245	53	
01A□AH1□	0.0430	0.005	0.0420	0.004	95	431	37	
01A□AHB□	0.0980	0.060	0.0970	0.059	192	895	53	
01A□AHC□	0.0880	0.050	0.0880	0.050	233	1087	53	
01A□AH7□	0.1030	0.065	0.1020	0.064	605	2581	75	
C2A□AH1□	0.0581	0.005	0.0571	0.004	95	431	37	
C2A□AHB□	0.1131	0.060	0.1121	0.059	192	895	53	
C2A□AHC□	0.1631	0.110	0.1611	0.108	528	2254	75	
C2A□AH7□	0.1181	0.065	0.1171	0.064	605	2581	75	
02A□AH1□	0.323	0.207	0.317	0.201	152	707	53	
02A□AHB□	0.309	0.193	0.308	0.192	192	895	53	
02A□AHC□	0.606	0.490	0.604	0.480	528	2254	75	
02A□AH7□	0.566	0.450	0.565	0.449	605	2581	75	
04A□AH1□	0.397	0.207	0.391	0.201	152	707	53	
04A□AHB□	0.760	0.570	0.750	0.560	435	1856	75	
04A□AHC□	0.680	0.490	0.678	0.488	528	2254	75	
04A□AH7□	0.810	0.620	0.800	0.610	951	4992	128	
06A□AH1□	1.026	0.700	0.986	0.660	343	1465	75	
06A□AHB□	0.896	0.570	0.886	0.560	435	1856	75	
06A□AHC□	1.166	0.840	1.146	0.820	830	4359	128	
06A□AH7□	0.946	0.620	0.936	0.610	951	4992	128	
08A□AH1□	1.469	0.700	1.429	0.660	343	1465	75	
08A□AHB□	1.369	0.600	1.359	0.590	435	1856	75	
08A□AHC□	3.77	3.000	3.75	2.980	830	4359	128	
08A□AH7□	3.57	2.800	3.56	2.790	951	4992	128	

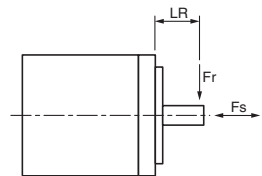

● Without Holding Brakes (With Holding Brakes)

(1) 50 to 150 W

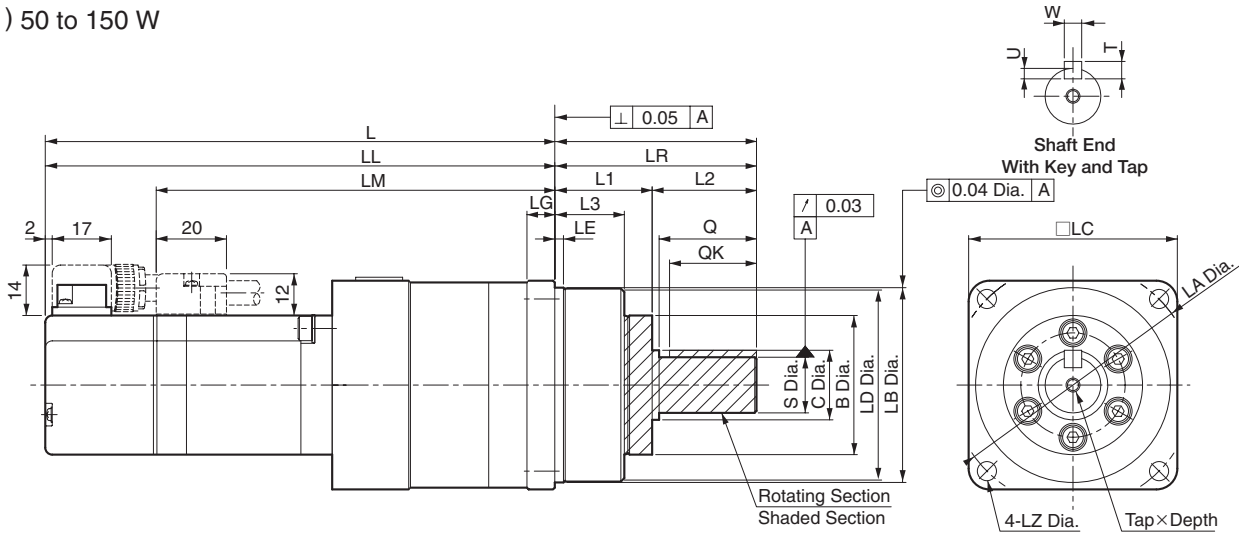

Model SGMAV-	Gear Ratio	L	LL	LM	Flange Face Dimensions								
					LR	LE	LG	B	LD	LB	LC	LA	LZ
A5A□AH1※1 (A5A□AH1※C)	1/5	152 (197)	110 (155)	78	42	2.2	5	29	39.5	40 ⁰ _{-0.025}	40	46	3.4
A5A□AH2※1 (A5A□AH2※C)	1/9												
A5A□AHC※1 (A5A□AHC※C)	1/21	161 (206)	119 (164)	87									
A5A□AH7※1 (A5A□AH7※C)	1/33	192.5 (237.5)	134.5 (179.5)	102.5	58	2.5	8	40	55.5	56 ⁰ _{-0.030}	60	70	5.5
01A□AH1※1 (01A□AH1※C)	1/5	164 (209)	122 (167)	90	42	2.2	5	29	39.5	40 ⁰ _{-0.025}	40	46	3.4
01A□AHB※1 (01A□AHB※C)	1/11	204.5 (249.5)	146.5 (191.5)	114.5	58	2.5	8	40	55.5	56 ⁰ _{-0.030}	60	70	5.5
01A□AHC※1 (01A□AHC※C)	1/21												
01A□AH7※1 (01A□AH7※C)	1/33	229 (274)	149 (194)	117	80	7.5	10	59	84	85 ⁰ _{-0.035}	90	105	9
C2A□AH1※1 (02A□AH1※C)	1/5	176 (225)	134 (179)	102	42	2.2	5	29	39.5	40 ⁰ _{-0.025}	40	46	3.4
C2A□AHB※1 (02A□AHB※C)	1/11	216.5 (261.5)	158.5 (203.5)	126.5	58	2.5	8	40	55.5	56 ⁰ _{-0.030}	60	70	5.5
C2A□AHC※1 (02A□AHC※C)	1/21	241 (286)	161 (206)	129	80	7.5	10	59	84	85 ⁰ _{-0.035}	90	105	9
C2A□AH7※1 (02A□AH7※C)	1/33												

Model SGMAV-	L1	L2	L3	Q	C	S (Shaft)	Tap × Depth	Key Dimensions				Approx. Mass kg
								QK	U	W	T	
A5A□AH1※1 (A5A□AH1※C)	22	-	14	20	-	8 ⁰ _{-0.015}	M3×6L	15	1.8	3	3	0.6 (0.9)
A5A□AH2※1 (A5A□AH2※C)												
A5A□AHC※1 (A5A□AHC※C)												
A5A□AH7※1 (A5A□AH7※C)	28	30	20	28	20	16 ⁰ _{-0.018}	M4×8L	25	3	5	5	1.3 (1.6)
01A□AH1※1 (01A□AH1※C)	22	-	14	20	-	8 ⁰ _{-0.015}	M3×6L	15	1.8	3	3	0.7 (1.0)
01A□AHB※1 (01A□AHB※C)												
01A□AHC※1 (01A□AHC※C)												
01A□AH7※1 (01A□AH7※C)	36	44	26	42	32	25 ⁰ _{-0.021}	M6×12L	36	4	8	7	2.8 (3.1)
C2A□AH1※1 (02A□AH1※C)	22	-	14	20	-	8 ⁰ _{-0.015}	M3×6L	15	1.8	3	3	0.8 (1.1)
C2A□AHB※1 (02A□AHB※C)												
C2A□AHC※1 (02A□AHC※C)												
C2A□AH7※1 (02A□AH7※C)	36	44	26	42	32	25 ⁰ _{-0.021}	M6×12L	36	4	8	7	2.9 (3.2)

※: The asterisk (*) describes the values of the 8th digit of the model designation, "shaft end code 6 (straight with key and tap)." If a key or tap is not necessary, order a servomotor with "shaft end code 2 (without key and tap)" or "shaft end code 8 (without key and with tap)."

Notes: 1 The models and values in parentheses are for servomotors with holding brakes.

2 Please note that gear dimensions are different from those of Σ-I, Σ-II, and Σ-III series.

With Low-backlash Gears External Dimensions Units: mm

● Flange Output Face

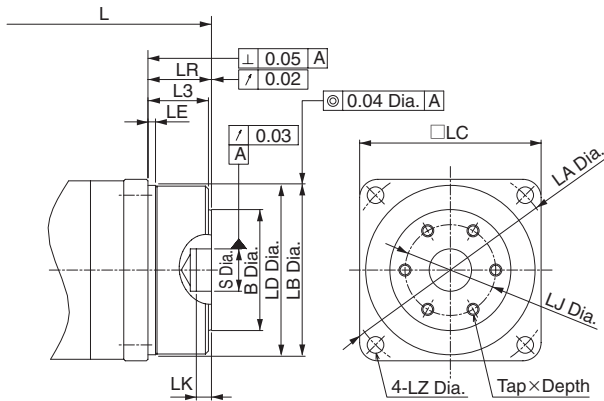

Model SGMAV-	Gear Ratio	L	LR	LJ	LK	S (Hole)	Tap × Depth	Approx. Mass kg
A5A□AH101 (A5A□AH10C)	1/5	125 (170)	15	18	3	8 ^{+0.015} ₀	3-M4×6L	0.6 (0.9)
A5A□AH201 (A5A□AH20C)	1/9							
A5A□AHC01 (A5A□AHC0C)	1/21							
A5A□AH701 (A5A□AH70C)	1/33	155.5 (200.5)	21	30	5	16 ^{+0.018} ₀	6-M4×7L	1.2 (1.5)
01A□AH101 (01A□AH10C)	1/5	137 (182)	15	18	3	8 ^{+0.015} ₀	3-M4×6L	0.7 (1.0)
01A□AHB01 (01A□AHB0C)	1/11	167.5 (212.5)	21	30	5	16 ^{+0.018} ₀	6-M4×7L	1.3 (1.6)
01A□AHC01 (01A□AHC0C)	1/21							
01A□AH701 (01A□AH70C)	1/33	176 (221)	27	45	5	25 ^{+0.021} ₀	6-M6×10L	2.4 (2.7)
C2A□AH101 (C2A□AH10C)	1/5	149 (194)	15	18	3	8 ^{+0.015} ₀	3-M4×6L	0.8 (1.1)
C2A□AHB01 (C2A□AHB0C)	1/11	179.5 (224.5)	21	30	5	16 ^{+0.018} ₀	6-M4×7L	1.4 (1.7)
C2A□AHC01 (C2A□AHC0C)	1/21	188 (233)	27	45	5	25 ^{+0.021} ₀	6-M6×10L	2.5 (2.8)
C2A□AH701 (C2A□AH70C)	1/33							

Notes: 1 The models and values in parentheses are for servomotors with holding brakes.
2 The dimensions not given on the table above are the same as those in the table on the previous page.

(2) 200 to 550 W

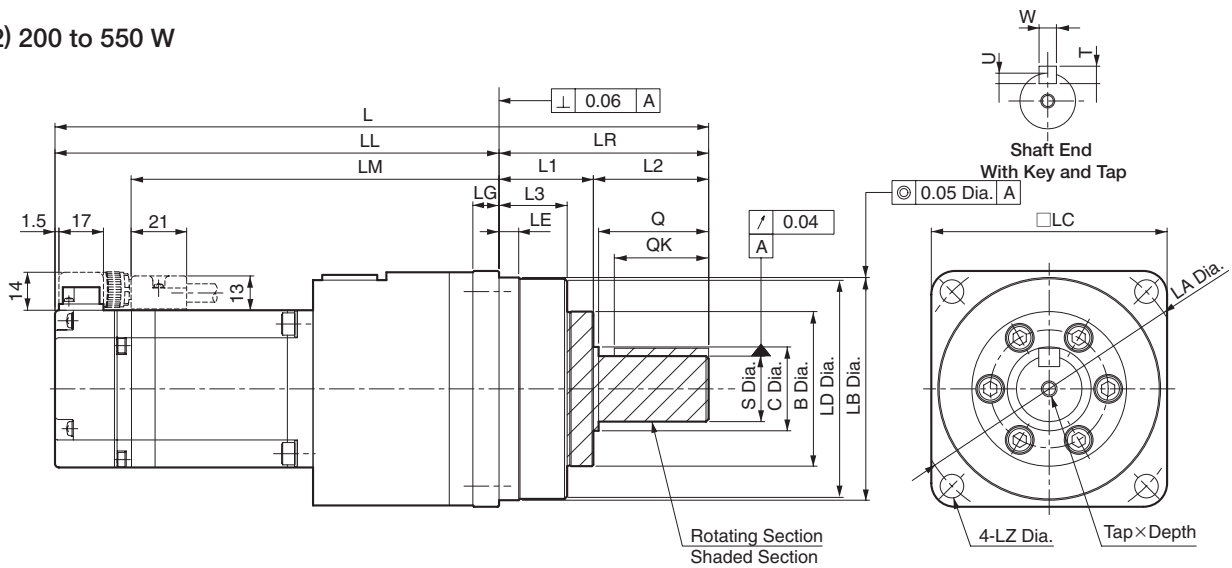

Model SGMAV-	Gear Ratio	L	LL	LM	Flange Face Dimensions									
					LR	LE	LG	B	LD	LB	LC	LA	LZ	
02A□AH1※1 (02A□AH1※C)	1/5	202 (242)	144 (184)	115	58	2.5	8	40	55.5	56 ⁰ _{-0.030}	60	70	5.5	
02A□AHB※1 (02A□AHB※C)	1/11													
02A□AHC※1 (02A□AHC※C)	1/21	231 (271)	151 (191)	122	80	7.5	10	59	84	85 ⁰ _{-0.035}	90	105	9	
02A□AH7※1 (02A□AH7※C)	1/33													
04A□AH1※1 (04A□AH1※C)	1/5	220.5 (260.5)	162.5 (202.5)	133.5	58	2.5	8	40	55.5	56 ⁰ _{-0.030}	60	70	5.5	
04A□AHB※1 (04A□AHB※C)	1/11	249.5 (289.5)	169.5 (209.5)	140.5	80	7.5	10	59	84	85 ⁰ _{-0.035}	90	105	9	
04A□AHC※1 (04A□AHC※C)	1/21													
04A□AH7※1 (04A□AH7※C)	1/33	335.5 (375.5)	202.5 (242.5)	173.5	133	12.5	13	84	114	115 ⁰ _{-0.035}	120	135	11	
06A□AH1※1 (06A□AH1※C)	1/5	275.5 (321.5)	195.5 (241.5)	166.5	80	7.5	10	59	84	85 ⁰ _{-0.035}	90	105	9	
06A□AHB※1 (06A□AHB※C)	1/11													
06A□AHC※1 (06A□AHC※C)	1/21	361.5 (407.5)	228.5 (274.5)	199.5	133	12.5	13	84	114	115 ⁰ _{-0.035}	120	135	11	
06A□AH7※1 (06A□AH7※C)	1/33													

Model SGMAV-	L1	L2	L3	Q	C	S	Tap × Depth	Key Dimensions				Approx. Mass kg
								QK	U	W	T	
02A□AH1※1 (02A□AH1※C)	28	30	20	28	20	16 ⁰ _{-0.018}	M4×8L	25	3	5	5	1.9 (2.5)
02A□AHB※1 (02A□AHB※C)												2.0 (2.6)
02A□AHC※1 (02A□AHC※C)	36	44	26	42	32	25 ⁰ _{-0.021}	M6×12L	36	4	8	7	3.8 (4.4)
02A□AH7※1 (02A□AH7※C)												
04A□AH1※1 (04A□AH1※C)	28	30	20	28	20	16 ⁰ _{-0.018}	M4×8L	25	3	5	5	2.2 (2.8)
04A□AHB※1 (04A□AHB※C)												
04A□AHC※1 (04A□AHC※C)	36	44	26	42	32	25 ⁰ _{-0.021}	M6×12L	36	4	8	7	4.1 (4.7)
04A□AH7※1 (04A□AH7※C)												
04A□AH7※1 (04A□AH7※C)	48	85	33	82	44	40 ⁰ _{-0.025}	M10×20L	70	5	12	8	8.7 (9.3)
06A□AH1※1 (06A□AH1※C)												
06A□AHB※1 (06A□AHB※C)	36	44	26	42	32	25 ⁰ _{-0.021}	M6×12L	36	4	8	7	4.4 (5.1)
06A□AHC※1 (06A□AHC※C)												4.6 (5.3)
06A□AH7※1 (06A□AH7※C)	48	85	33	82	44	40 ⁰ _{-0.025}	M10×20L	70	5	12	8	9.2 (9.9)

※: The asterisk (*) describes the values of the 8th digit of the model designation, "shaft end code 6 (straight with key and tap)." If a key or tap is not necessary, order a servomotor with "shaft end code 2 (without key and tap)" or "shaft end code 8 (without key and with tap)."

Notes: 1 The models and values in parentheses are for servomotors with holding brakes.

2 Please note that gear dimensions are different from those of Σ-I, Σ-II, and Σ-III series.

With Low-backlash Gears External Dimensions Units: mm

● Flange Output Face

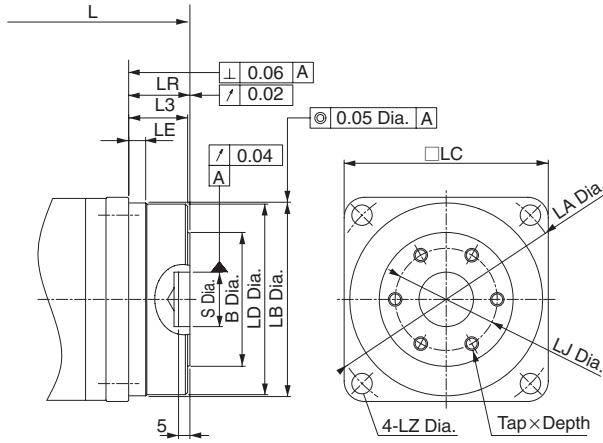

Model SGMAV-	Gear Ratio	L	LR	LJ	S (Hole)	Tap × Depth	Approx. Mass kg
02A□AH101 (02A□AH10C)	1/5	165 (205)	21	30	16 ^{+0.018} ₀	6-M4×7L	1.8 (2.4)
02A□AHB01 (02A□AHB0C)	1/11						1.9 (2.5)
02A□AHC01 (02A□AHC0C)	1/21	178 (218)	27	45	25 ^{+0.021} ₀	6-M6×10L	3.4 (4.0)
02A□AH701 (02A□AH70C)	1/33						
04A□AH101 (04A□AH10C)	1/5	183.5 (223.5)	21	30	16 ^{+0.018} ₀	6-M4×7L	2.1 (2.7)
04A□AHB01 (04A□AHB0C)	1/11	196.5 (236.5)	27	45	25 ^{+0.021} ₀	6-M6×10L	3.7 (4.3)
04A□AHC01 (04A□AHC0C)	1/21						
04A□AH701 (04A□AH70C)	1/33	237.5 (277.5)	35	60	40 ^{+0.025} ₀	6-M8×12L	7.3 (7.9)
06A□AH101 (06A□AH10C)	1/5	222.5 (268.5)	27	45	25 ^{+0.021} ₀	6-M6×10L	4.0 (4.7)
06A□AHB01 (06A□AHB0C)	1/11						4.2 (4.9)
06A□AHC01 (06A□AHC0C)	1/21	263.5 (309.5)	35	60	40 ^{+0.025} ₀	6-M8×12L	7.8 (8.5)
06A□AH701 (06A□AH70C)	1/33						

Notes: 1 The models and values in parentheses are for servomotors with holding brakes.
2 The dimensions not given on the table above are the same as those in the table on the previous page.

(3) 750 W

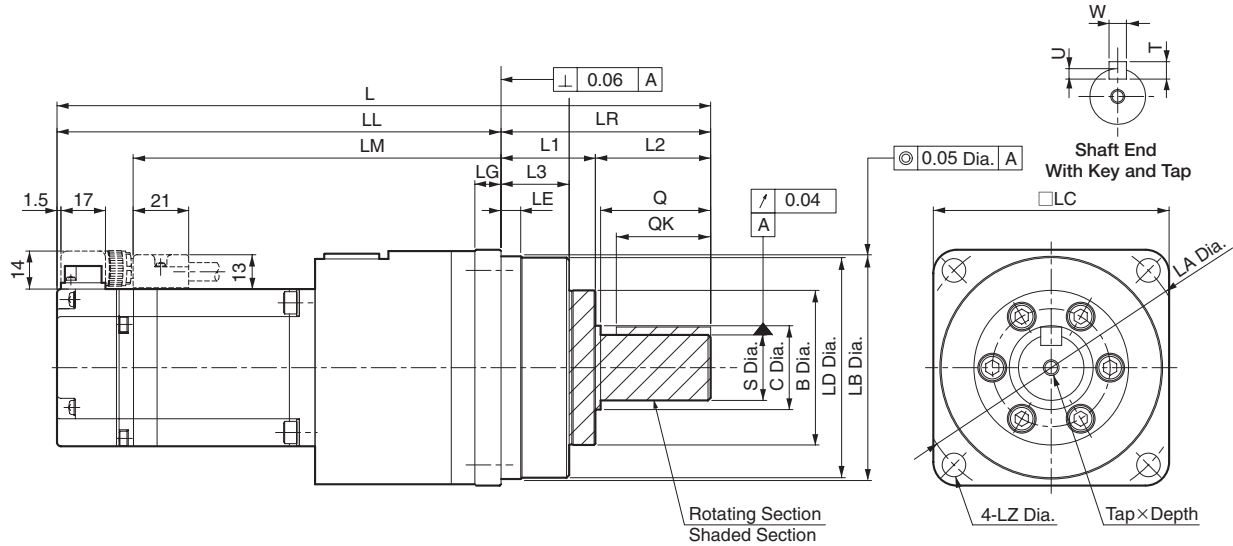

Model SGMAV-	Gear Ratio	L	LL	LM	Flange Face Dimensions									
					LR	LE	LG	B	LD	LB	LC	LA	LZ	
08A□AH1※1 (08A□AH1※C)	1/5	273 (318)	193 (238)	163	80	7.5	10	59	84	85	90	105	9	
08A□AHB※1 (08A□AHB※C)	1/11													
08A□AHC※1 (08A□AHC※C)	1/21	352 (397)	219 (264)	189	133	12.5	13	84	114	115	120	135	11	
08A□AH7※1 (08A□AH7※C)	1/33													

Model SGMAV-	L1	L2	L3	Q	C	S	Tap × Depth	Key Dimensions				Approx. Mass kg
								QK	U	W	T	
08A□AH1※1 (08A□AH1※C)	36	44	26	42	32	25	M6×12L	36	4	8	7	5.2 (6.1)
08A□AHB※1 (08A□AHB※C)												5.4 (6.3)
08A□AHC※1 (08A□AHC※C)	48	85	33	82	44	40	M10×20L	70	5	12	8	10.1 (11)
08A□AH7※1 (08A□AH7※C)												

: The asterisk () describes the values of the 8th digit of the model designation, "shaft end code 6 (straight with key and tap)." If a key or tap is not necessary, order a servomotor with "shaft end code 2 (without key and tap)" or "shaft end code 8 (without key and with tap)."

Notes: 1 The models and values in parentheses are for servomotors with holding brakes.
 2 Please note that gear dimensions are different from those of Σ-I, Σ-II, and Σ-III series.

With Low-backlash Gears External Dimensions Units: mm

● Flange Output Face

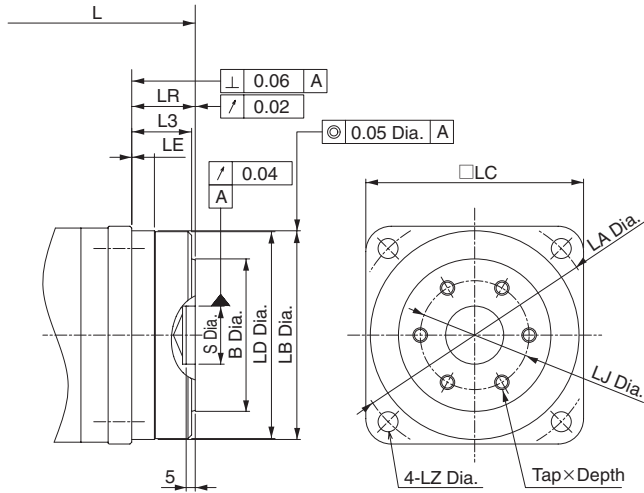

Model SGMAV-	Gear Ratio	L	LR	LJ	S (Hole)	Tap × Depth	Approx. Mass kg
08A□AH101 (08A□AH10C)	1/5	220 (265)	27	45	25 ^{+0.021} ₀	6-M6×10L	4.8 (5.7)
08A□AHB01 (08A□AHB0C)	1/11						5.0 (5.9)
08A□AHC01 (08A□AHC0C)	1/21	254 (299)	35	60	40 ^{+0.025} ₀	6-M8×12L	8.7 (9.6)
08A□AH701 (08A□AH70C)	1/33						

Notes: 1 The models and values in parentheses are for servomotors with holding brakes.
2 The dimensions not given on the table above are the same as those in the table on the previous page.

Rotary Servomotors

SGMGV

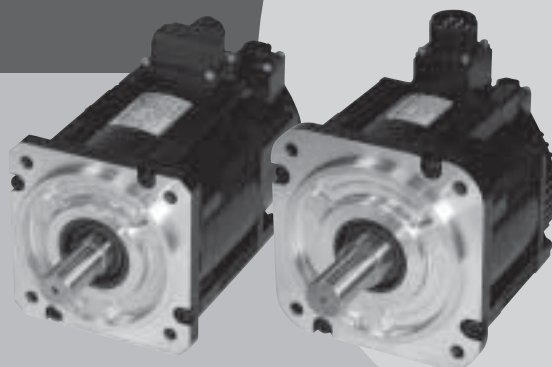

Model Designations

Without Gears

SGMGV - 03 D 3 A 2 1

1st+2nd digits 3rd digit 4th digit 5th digit 6th digit 7th digit

1st+2nd digits Rated Output

Code	Specifications	Code	Specifications
03	300 W	20	1.8 kW
05	450 W	30	2.9 kW
09	850 W	44	4.4 kW
13	1.3 kW		

3rd digit Power Supply Voltage

Code	Specifications
D	400 VAC

4th digit Serial Encoder

Code	Specifications
D	20-bit incremental (standard)
3	20-bit absolute (standard)

5th digit Design Revision Order

Code	Specifications
A	Standard

6th digit Shaft End

Code	Specifications
2	Straight without key (standard)
6	Straight with key and tap (optional)

7th digit Options

Code	Specifications
1	Without options
B	With holding brake (90 VDC)
C	With holding brake (24 VDC)
D	With oil seal and holding brake (90 VDC)
E	With oil seal and holding brake (24 VDC)
S	With oil seal

Features

- High-speed driving of feed shafts for various machines
- Wide selection: 300 W to 4.4 kW capacity, holding brake option
- Mounted serial encoder: 20 bits, high resolution
- Protective structure: IP67

Application Examples

- Machine tools
- Transfer machines
- Material handling machines
- Food processing equipment

Configurations of connectors for the main circuit vary depending on servomotor capacity.

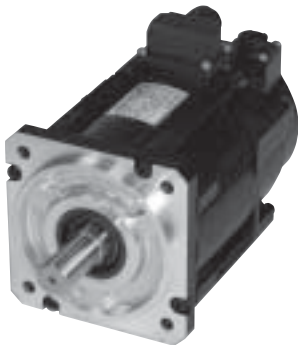

SGMGV-03/-05

The connectors are used only for Yaskawa servomotors. Order the connectors specified by Yaskawa. Both protective structure IP67 and European Safety Standards compliant connectors are available.

Note: Connectors are not provided by Yaskawa.

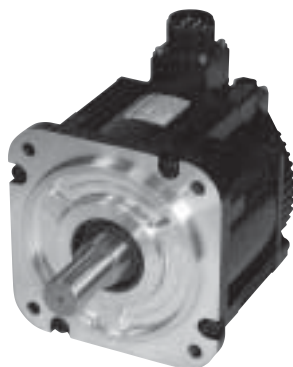

SGMGV-09 to -44

The connectors for these models are round. The connectors specified by Yaskawa are required. Note that the connectors vary depending on the operation environment of servomotors.

Two types of connectors are available.

- Standard connectors
- Protective structure IP67 and European Safety Standards compliant connectors

Note: Connectors are not provided by Yaskawa.

Ratings and Specifications

Time Rating: Continuous
Vibration Class: V15
Insulation Resistance: 500 VDC, 10 MΩ min.
Ambient Temperature: 0 to 40°C
Excitation: Permanent magnet
Mounting: Flange method

Thermal Class: F
Withstand Voltage: 1800 VAC for one minute
Enclosure: Totally enclosed, self-cooled, IP67
 (except for shaft opening)
Ambient Humidity: 20% to 80% (no condensation)
Drive Method: Direct drive
Rotation Direction: Counterclockwise (CCW)

Voltage		400 V						
Servomotor Model: SGMGV-□□□		03D	05D	09D	13D	20D	30D	44D
Rated Output*	kW	0.3	0.45	0.85	1.3	1.8	2.9	4.4
Rated Torque*	N·m	1.96	2.86	5.39	8.34	11.5	18.6	28.4
Instantaneous Peak Torque*	N·m	5.88	8.92	13.8	23.3	28.7	45.1	71.1
Rated Current*	Arms	1.4	1.9	3.5	5.4	8.4	11.9	16.5
Instantaneous Max. Current*	Arms	4	5.5	8.5	14	20	28	40.5
Rated Speed*	min ⁻¹	1500						
Max. Speed*	min ⁻¹	3000						
Torque Constant	N·m/Arms	1.55	1.71	1.72	1.78	1.50	1.70	1.93
Rotor Moment of Inertia	kg·m ² ×10 ⁻⁴	2.48 (2.69)	3.33 (3.54)	13.9 (16)	19.9 (22)	26 (28.1)	46 (54.5)	67.5 (76.0)
Rated Power Rate*	kW/s	15.5 (14.3)	24.6 (23.1)	20.9 (18.2)	35.0 (31.6)	50.9 (47.1)	75.2 (63.5)	119 (106)
Rated Angular Acceleration*	rad/s ²	7900 (7290)	8590 (8080)	3880 (3370)	4190 (3790)	4420 (4090)	4040 (3410)	4210 (3740)
Applicable SERVOPACK SGD□-□□□□		1R9D	1R9D	3R5D	5R4D	8R4D	120D	170D

*: These items and torque-motor speed characteristics quoted in combination with a SERVOPACK are at an armature winding temperature of 20°C.
 Notes: 1 The values in parentheses are for servomotors with holding brakes.
 2 The above specifications show the values under the cooling condition when the following heat sinks are mounted on the servomotors.
 SGMGV-03/-05: 250 mm × 250 mm × 6 mm (aluminum)
 SGMGV-09/-13/-20: 400 mm × 400 mm × 20 mm (iron)
 SGMGV-30/-44: 550 mm × 550 mm × 30 mm (iron)

● Torque-Motor Speed Characteristics A : Continuous Duty Zone B : Intermittent Duty Zone

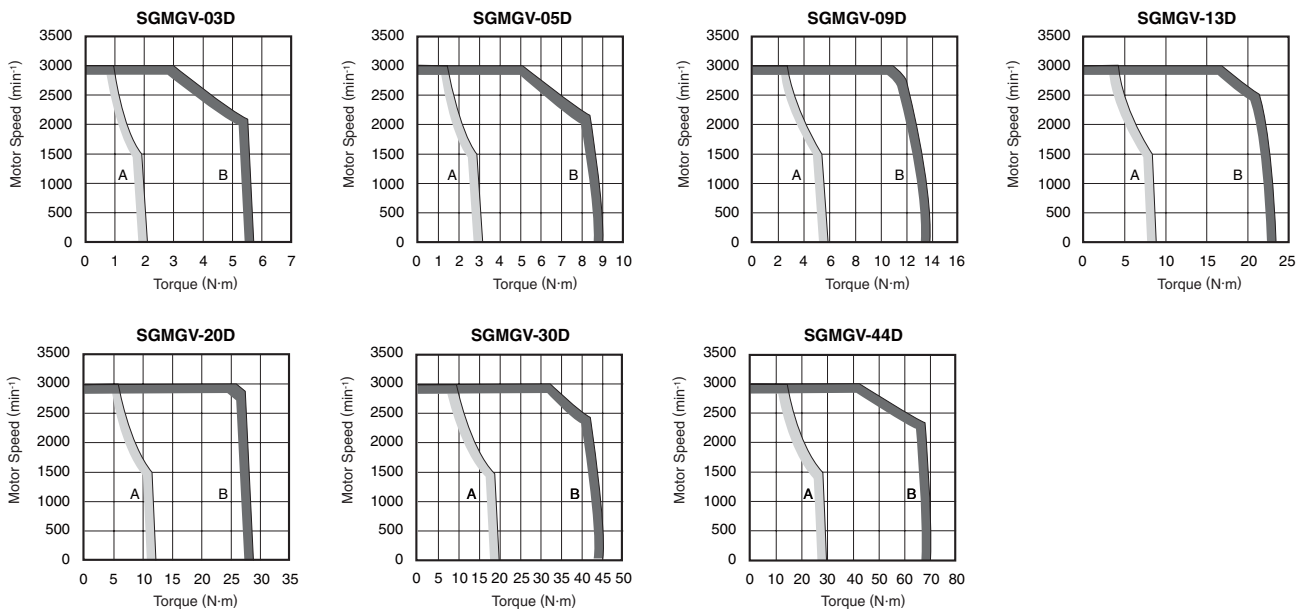

Ratings and Specifications

● **Holding Brake Electrical Specifications**

Servomotor Model	Servomotor Rated Output kW	Holding Brake Specifications				
		Holding Torque N·m	Rated Voltage 24 VDC		Rated Voltage 90 VDC	
			Capacity W	Rated Current A (at 20°C)	Capacity W	Rated Current A (at 20°C)
SGMGV-03	0.3	4.5	10	0.42	10	0.11
SGMGV-05	0.45	4.5	10	0.42	10	0.11
SGMGV-09	0.85	12.7	9.8	0.41	10.1	0.11
SGMGV-13	1.3	19.6	9.8	0.41	10.1	0.11
SGMGV-20	1.8	19.6	9.8	0.41	10.1	0.11
SGMGV-30	2.9	43.1	18.5	0.77	18.5	0.21
SGMGV-44	4.4	43.1	18.5	0.77	18.5	0.21

Note: The holding brake is only used to hold the load and cannot be used to stop the servomotor.

● **Allowable Load Moment of Inertia at the Motor Shaft**

The rotor moment of inertia ratio is the value for a servomotor without a gear and a brake.

Servomotor Model	Servomotor Rated Output	Allowable Load Moment of Inertia (Rotor Moment of Inertia Ratio)
SGMGV	0.3 to 4.4 kW	5 times

● **Load Moment of Inertia**

The larger the load moment of inertia, the worse the movement response of the load.

The allowable load moment of inertia (J_L) depends on motor capacity and is limited to within 5 to 30 times the rotor moment of inertia of each servomotor (J_M). This value is provided strictly as a guideline and results may vary depending on servomotor drive conditions.

An overvoltage alarm (A.400) is likely to occur during deceleration if the load moment of inertia exceeds the allowable load moment of inertia. SERVOPACKs with a built-in regenerative resistor may generate a regenerative overload alarm (A.320). Take one of the following steps if this occurs.

- Reduce the torque limit.
- Reduce the deceleration rate.
- Reduce the maximum speed.
- Install an external regenerative resistor if the alarm cannot be cleared. Contact your Yaskawa representative.

● **Allowable Radial and Thrust Loads**

Design the mechanical system so thrust and radial loads applied to the servomotor shaft end during operation fall within the ranges shown in the table.

Servomotor Model	Allowable Radial Load (Fr) N	Allowable Thrust Load (Fs) N	LR mm	Reference Diagram	
SGMGV-	03D□A21	490	98	37	
	05D□A21	490	98	40	
	09D□A21	490	98	58	
	13D□A21	686	343	58	
	20D□A21	980	392	58	
	30D□A21	1470	490	79	
	44D□A21	1470	490	79	

External Dimensions Units: mm

● Without Holding Brakes

(1) 300 W, 450 W

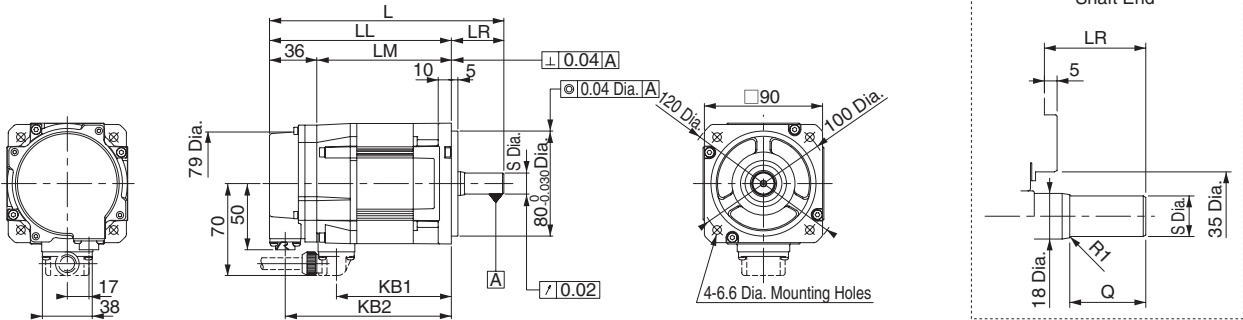

Note: For the specifications of the other shaft ends, refer to page 55.

Model SGMGV-	L	LL	LM	LR	KB1	KB2	Shaft End Dimensions		Approx. Mass kg
							S	Q	
03D□A21	163	126	90	37	75	114	14 ⁰ _{0.011}	25	2.6
05D□A21	179	139	103	40	88	127	16 ⁰ _{0.011}	30	3.2

Note: Models with oil seals are of the same configuration.

· Cable Specifications for Encoder-end Connector (20-bit Encoder)

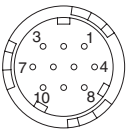

Receptacle: CM10-R10P-D
 Applicable plug (To be provided by the customer)
 Plug: CM10-AP10S-*⁻D (Angle)
 CM10-SP10S-*⁻D (Straight)
 (Asterisks(*) indicate a value that varies, depending on cable size.)

· Cable Specifications for Servomotor-end Connector

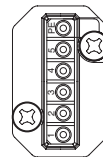

PE	FG (Frame ground)
5	-
4	-
3	Phase U
2	Phase V
1	Phase W

With an Absolute Encoder

1	PS	6	BAT (+)
2	/PS	7	-
3	-	8	-
4	PG 5V	9	PG 0V
5	BAT (-)	10	FG (Frame ground)

With an Incremental Encoder

1	PS	6	-
2	/PS	7	-
3	-	8	-
4	PG 5V	9	PG 0V
5	-	10	FG (Frame ground)

External Dimensions Units: mm

(2) 850 W to 4.4 kW

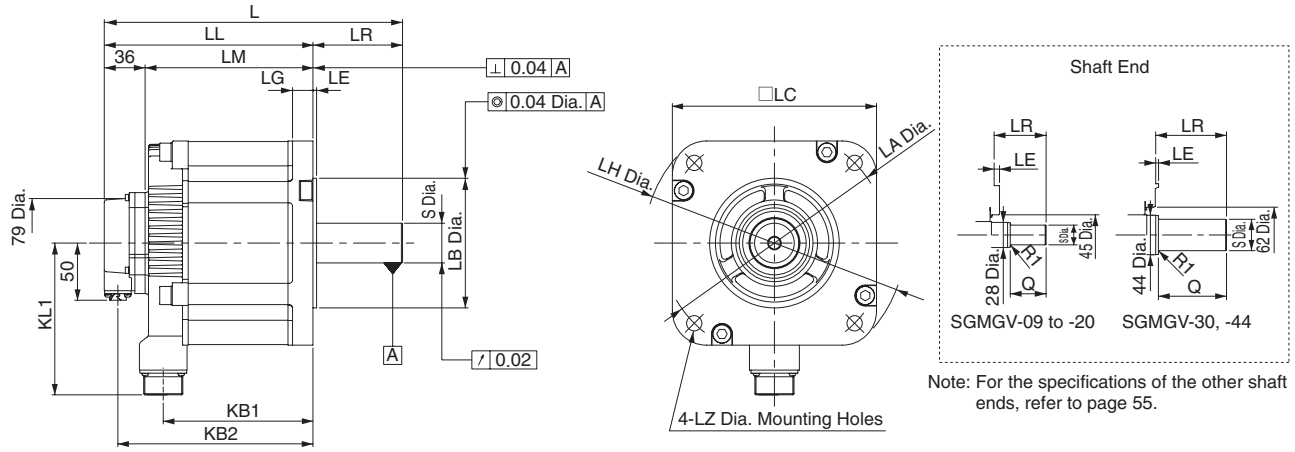

Note: For the specifications of the other shaft ends, refer to page 55.

Model SGMGV-	L	LL	LM	LR	KB1	KB2	KL1	Flange Face Dimensions						Shaft End Dimensions		Approx. Mass kg	
								LA	LB	LC	LE	LG	LH	LZ	S		Q
09D□A21	195	137	101	58	83	125	104	145	110 ⁰ _{-0.035}	130	6	12	165	9	19 ⁰ _{-0.013}	40	5.5
13D□A21	211	153	117	58	99	141	104	145	110 ⁰ _{-0.035}	130	6	12	165	9	22 ⁰ _{-0.013}	40	7.1
20D□A21	229	171	135	58	117	159	104	145	110 ⁰ _{-0.035}	130	6	12	165	9	24 ⁰ _{-0.013}	40	8.6
30D□A21	239	160	124	79	108	148	134	200	114.3 ⁰ _{-0.025}	180	3.2	18	230	13.5	35 ^{+0.01} ₀	76	13.4
44D□A21	263	184	148	79	132	172	134	200	114.3 ⁰ _{-0.025}	180	3.2	18	230	13.5	35 ^{+0.01} ₀	76	17.5

Note: Models with oil seals are of the same configuration.

• Cable Specifications for Encoder-end Connector (20-bit Encoder)

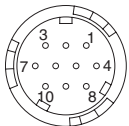

Receptacle: CM10-R10P-D
Applicable plug (To be provided by the customer)
Plug: CM10-AP10S-□-D (Angle)
CM10-SP10S-□-D (Straight)
(Asterisks (□) indicate a value that varies, depending on cable size.)

• Cable Specifications for Servomotor-end Connector

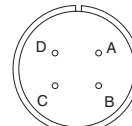

A	Phase U
B	Phase V
C	Phase W
D	FG (Frame ground)

With an Absolute Encoder

1	PS	6	BAT (+)
2	/PS	7	-
3	-	8	-
4	PG 5V	9	PG 0V
5	BAT (-)	10	FG (Frame ground)

With an Incremental Encoder

1	PS	6	-
2	/PS	7	-
3	-	8	-
4	PG 5V	9	PG 0V
5	-	10	FG (Frame ground)

External Dimensions Units: mm

● With Holding Brakes

(1) 300 W, 450 W

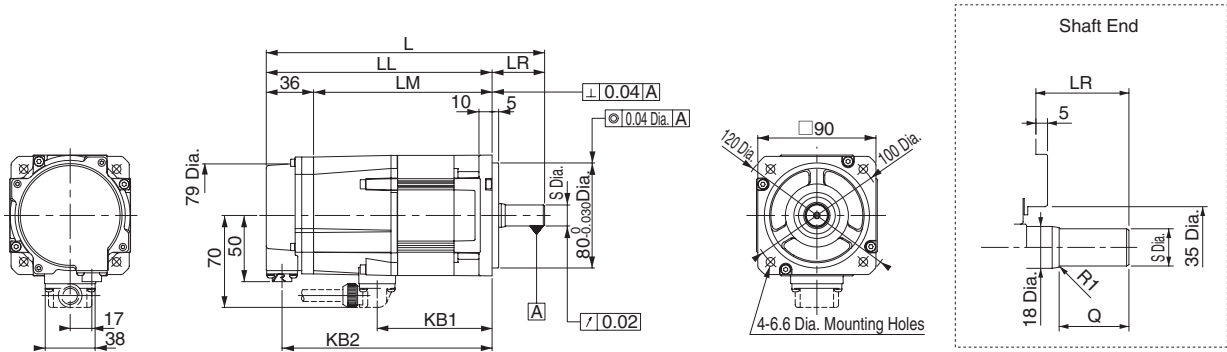

Note: For the specifications of the other shaft ends, refer to page 55.

Model SGMGV-	L	LL	LM	LR	KB1	KB2	Shaft End Dimensions		Approx. Mass kg
							S	Q	
03D□A2□	196	159	123	37	75	147	14 _{0.011} ⁰	25	4.5
05D□A2□	212	172	136	40	88	160	16 _{0.011} ⁰	30	5.0

Note: Models with oil seals are of the same configuration.

· Cable Specifications for Encoder-end Connector (20-bit Encoder)

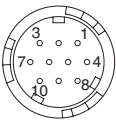

Receptacle: CM10-R10P-D
 Applicable plug (To be provided by the customer)
 Plug: CM10-AP10S-□-D (Angle)
 CM10-SP10S-□-D (Straight)
 (Asterisks (*) indicate a value that varies, depending on cable size.)

· Cable Specifications for Servomotor-end Connector

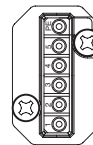

PE	FG (Frame ground)
5	Brake terminal
4	Brake terminal
3	Phase U
2	Phase V
1	Phase W

With an Absolute Encoder

1	PS	6	BAT (+)
2	/PS	7	-
3	-	8	-
4	PG 5V	9	PG 0V
5	BAT (-)	10	FG (Frame ground)

With an Incremental Encoder

1	PS	6	-
2	/PS	7	-
3	-	8	-
4	PG 5V	9	PG 0V
5	-	10	FG (Frame ground)

External Dimensions Units: mm

(2) 850 W to 4.4 kW

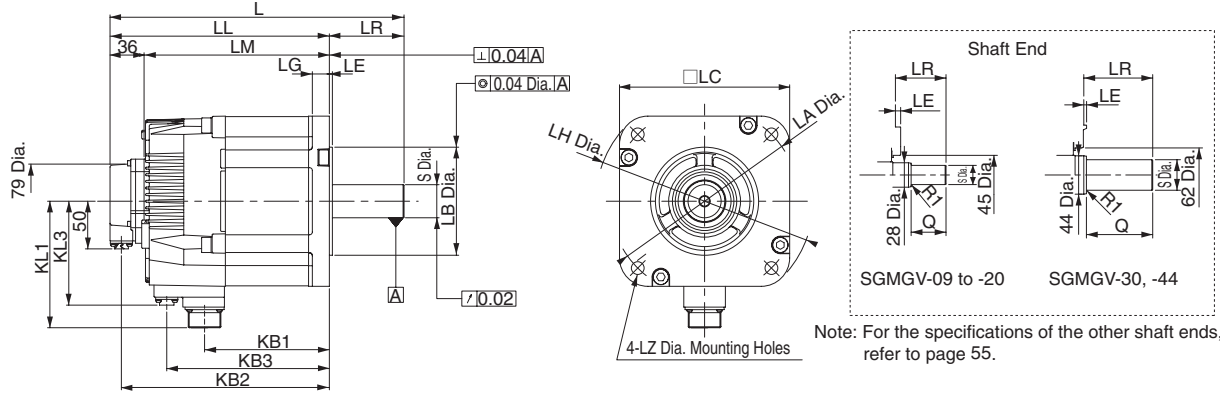

Note: For the specifications of the other shaft ends, refer to page 55.

Model SGMGV-	L	LL	LM	LR	KB1	KB2	KB3	KL1	KL3	Flange Face Dimensions						Shaft End Dimensions		Approx. Mass kg	
										LA	LB	LC	LE	LG	LH	LZ	S		Q
09D□A2□	231	173	137	58	83	161	115	104	80	145	110 ⁰ _{-0.035}	130	6	12	165	9	19 ⁰ _{-0.013}	40	7.5
13D□A2□	247	189	153	58	99	177	131	104	80	145	110 ⁰ _{-0.035}	130	6	12	165	9	22 ⁰ _{-0.013}	40	9.0
20D□A2□	265	207	171	58	117	195	149	104	80	145	110 ⁰ _{-0.035}	130	6	12	165	9	24 ⁰ _{-0.013}	40	11.0
30D□A2□	287	208	172	79	108	196	148	134	110	200	114.3 ⁰ _{-0.025}	180	3.2	18	230	13.5	35 ^{+0.01} ₀	76	19.5
44D□A2□	311	232	196	79	132	220	172	134	110	200	114.3 ⁰ _{-0.025}	180	3.2	18	230	13.5	35 ^{+0.01} ₀	76	23.5

Note: Models with oil seals are of the same configuration.

• Cable Specifications for Encoder-end Connector (20-bit Encoder)

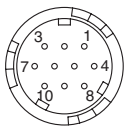

Receptacle: CM10-R10P-D
Applicable plug (To be provided by the customer)
Plug: CM10-AP10S-*D (Angle)
CM10-SP10S-*D (Straight)
(Asterisks (*) indicate a value that varies, depending on cable size.)

• Cable Specifications for Servomotor-end Connector

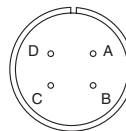

A	Phase U
B	Phase V
C	Phase W
D	FG (Frame ground)

With an Absolute Encoder

1	PS	6	BAT (+)
2	/PS	7	-
3	-	8	-
4	PG 5V	9	PG 0V
5	BAT (-)	10	FG (Frame ground)

With an Incremental Encoder

1	PS	6	-
2	/PS	7	-
3	-	8	-
4	PG 5V	9	PG 0V
5	-	10	FG (Frame ground)

• Cable Specifications for Brake-end Connector

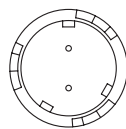

Receptacle: CM10-R2P-D
Applicable plug (To be provided by the customer)
Plug: CM10-AP2S-*D (Angle)
CM10-SP2S-*D (Straight)
(Asterisks (*) indicate a value that varies, depending on cable size.)

Brake terminal
Brake terminal

Note: No polarity for connection to the brake terminals

External Dimensions Units: mm

● Shaft End

SGMGV -

Code	Specifications	Remarks
2	Straight without key	Standard
6	Straight with key and tap for one location (Key slot is JIS B1301-1996 fastening type)	Optional

Code	Specifications	Shaft End	Model SGMGV-							
			03	05	09	13	20	30	44	
2	Straight without Key		LR	37	40	58	58	58	79	79
			Q	25	30	40	40	40	76	76
			S	14 ⁰ _{-0.011}	16 ⁰ _{-0.011}	19 ⁰ _{-0.013}	22 ⁰ _{-0.013}	24 ⁰ _{-0.013}	35 ^{+0.01} ₀	35 ^{+0.01} ₀
6	Straight with Key and Tap		LR	37	40	58	58	58	79	79
			Q	25	30	40	40	40	76	76
			QK	15	20	25	25	25	60	60
			S	14 ⁰ _{-0.011}	16 ⁰ _{-0.011}	19 ⁰ _{-0.013}	22 ⁰ _{-0.013}	24 ⁰ _{-0.013}	35 ^{+0.01} ₀	35 ^{+0.01} ₀
			W	5	5	5	6	8	10	10
			T	5	5	5	6	7	8	8
			U	3	3	3	3.5	4	5	5
P	M4 Screw, Depth 10	M5 Screw, Depth 12	M5 Screw, Depth 12	M5 Screw, Depth 12	M5 Screw, Depth 12	M12 Screw, Depth 25	M12 Screw, Depth 25			

Selecting Cables (SGMGV-03 / -05)

● **Cables Connections**

- Standard Wiring (Max. encoder cable length: 20 m)
- Encoder Cable Extension from 30 to 50 m (See page 64.)

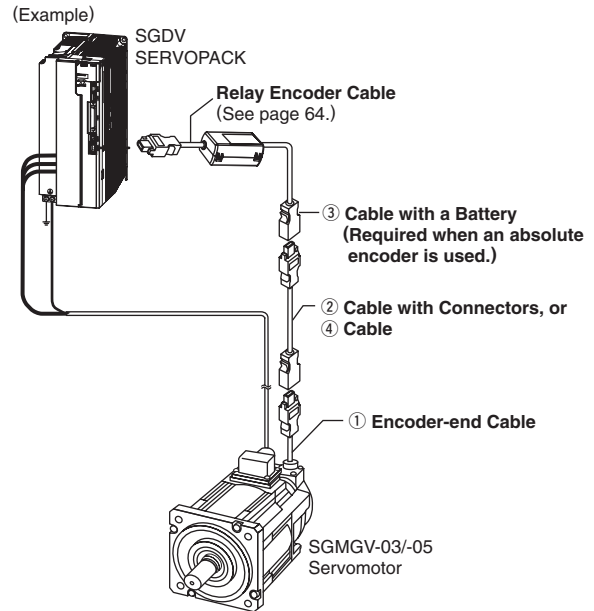
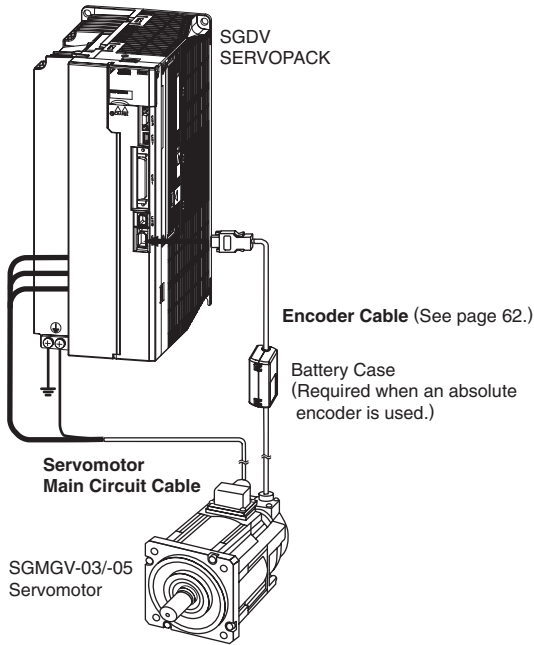

⚠ CAUTION

Separate the servomotor main circuit wiring from the signal line and encoder (PG) feedback line at least 30 cm, and do not bundle or run them in the same duct.

● **Servomotor Main Circuit Cable**

Contact Yaskawa Controls Co., Ltd.

Servomotor Rated Output kW	Name	Length	Order No.	Specifications	Details
			Standard (Flexible) Type*		
0.3 kW 0.45 kW	For Servomotor without Holding Brakes	3 m	JZSP-CVM21-03-E		(1)
		5 m	JZSP-CVM21-05-E		
		10 m	JZSP-CVM21-10-E		
		15 m	JZSP-CVM21-15-E		
		20 m	JZSP-CVM21-20-E		
		30 m	JZSP-CVM21-30-E		
		40 m	JZSP-CVM21-40-E		
	50 m	JZSP-CVM21-50-E			
	For Servomotor with Holding Brakes	3 m	JZSP-CVM41-03-E		(2)
		5 m	JZSP-CVM41-05-E		
		10 m	JZSP-CVM41-10-E		
		15 m	JZSP-CVM41-15-E		
		20 m	JZSP-CVM41-20-E		
		30 m	JZSP-CVM41-30-E		
40 m		JZSP-CVM41-40-E			
50 m	JZSP-CVM41-50-E				
	Servomotor-end Connector Kit	—	JZSP-CVM9-1-E	Crimping Type (A crimp tool is required.)	(3)

* These flexible cables are provided as standard equipment.

(Cont'd)

Selecting Cables (SGMGV-03 / -05)

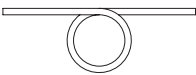
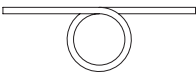
Servomotor Rated Output kW	Name		Length	Order No.	Specifications	Details
				Standard (Flexible) Type*		
0.3 kW 0.45 kW	Cables	For Servomotor without Holding Brakes (4 wires)	5 m	JZSP-CVM29-05-E		(4)
			10 m	JZSP-CVM29-10-E		
			15 m	JZSP-CVM29-15-E		
			20 m	JZSP-CVM29-20-E		
			30 m	JZSP-CVM29-30-E		
			40 m	JZSP-CVM29-40-E		
			50 m	JZSP-CVM29-50-E		
		For Servomotor with Holding Brakes (6 wires)	5 m	JZSP-CVM49-05-E		(4)
			10 m	JZSP-CVM49-10-E		
			15 m	JZSP-CVM49-15-E		
			20 m	JZSP-CVM49-20-E		
			30 m	JZSP-CVM49-30-E		
			40 m	JZSP-CVM49-40-E		
			50 m	JZSP-CVM49-50-E		

*: These flexible cables are provided as standard equipment.

(1) Wiring Specifications for Servomotors without Holding Brakes

SERVOPACK-end Leads		Servomotor-end Connector	
Wire Color	Signal	Signal	Pin No.
Green/yellow	FG	FG	PE
Blue	Phase W	Phase W	1
White	Phase V	Phase V	2
Red	Phase U	Phase U	3
		-	4
		-	5

(2) Wiring Specifications for Servomotor with Holding Brakes

SERVOPACK-end Leads		Servomotor-end Connector	
Wire Color	Signal	Signal	Pin No.
Green/yellow	FG	FG	PE
Blue	Phase W	Phase W	1
White	Phase V	Phase V	2
Red	Phase U	Phase U	3
Black	Brake	Brake	4
Black	Brake	Brake	5

Note: No polarity for connection to a holding brake

(3) Servomotor-end Connector Kit Specifications

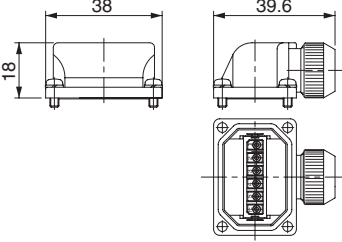
Items	Specifications	Dimensional Drawings mm
Order No.	JZSP-CVM9-1-E (Cables are not included.)	
Applicable Servomotors	SGMGV-03/-05	
Manufacturer	Japan Aviation Electronics Industry, Ltd.	
Plug	JNYFX06SJ3	
Electrical Contact	ST-TMH-S-C1B	
Applicable Wire Size	AWG18 to 22	
Outer Diameter of Insulating Sheath	1.3 dia. to 2.6 dia.	
Crimp Tool	Hand tool: CT160-3-TMH5B Applicator: 350-TMH5B-2B	
Mounting Screw	M3 Pan head screw	
Applicable Cable Outer Diameter	6.9 dia. to 8.3 dia.	

(4) Cable Specifications (Flexible Type)

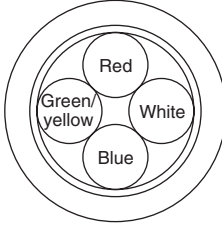
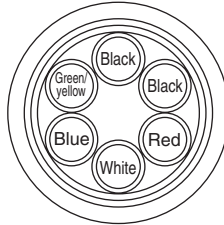
Items	For Servomotor without Holding Brakes (4 wires)	For Servomotor with Holding Brakes (6 wires)
Order No.*	JZSP-CVM29-□□-E	JZSP-CVM49-□□-E
Cable Length	50 m max.	
Specifications	UL2586 (Max. operating temperature: 105°C) AWG20×4C For power line: AWG20 (0.55 mm ²) Outer diameter of insulating sheath: 1.77 dia.	UL2586 (Max. operating temperature: 105°C) AWG20×6C For power line: AWG20 (0.55 mm ²) Outer diameter of insulating sheath: 1.77 dia. For brake line: AWG20 (0.55 mm ²) Outer diameter of insulating sheath: 1.77 dia.
Finished Dimensions	7.3 0.3 dia.	7.4 0.3 dia.
Internal Configuration and Lead Color		
Yaskawa Standard Specifications (Standard Length)	Cable length: 5 m, 10 m, 15 m, 20 m, 30 m, 40 m, 50 m	

*: Specify the cable length in □□ of order no.
Example: JZSP-CVM□□-05-E (5 m)

Selecting Cables (SGMGV-09 to -44)

● **Cables Connections**

- Standard Wiring (Max. encoder cable length: 20 m)
- Encoder Cable Extension from 30 to 50 m (See page 64.)

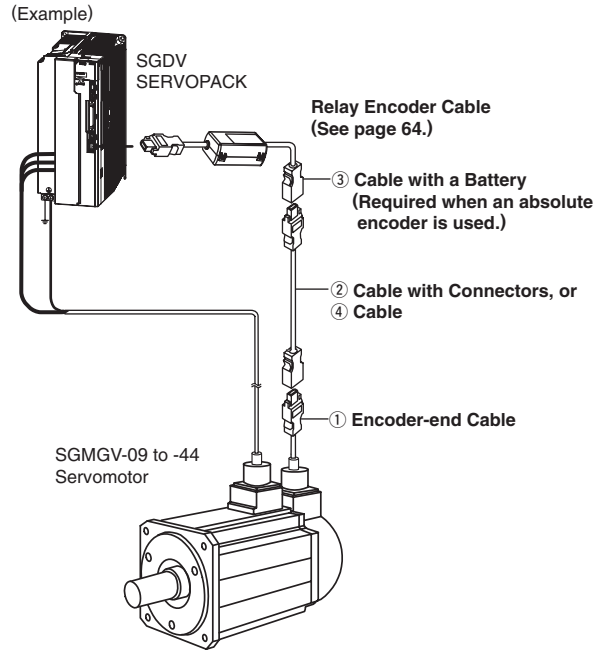
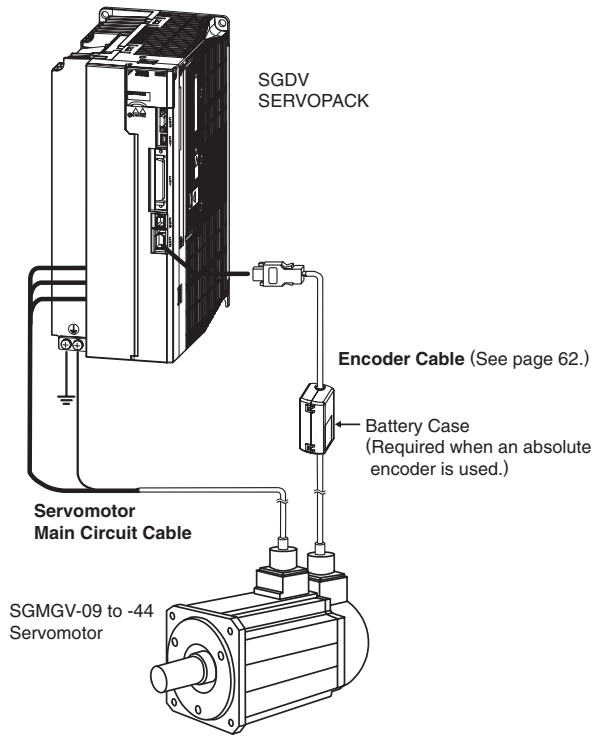

⚠ CAUTION

Separate the servomotor main circuit wiring from the signal line and encoder (PG) feedback line at least 30 cm, and do not bundle or run them in the same duct.

● **Servomotor Main Circuit Cables**

Customers must assemble the servomotor's main circuit cables and attach connectors to connect the SERVOPACKs and the SGMGV servomotors.

Use the connectors specified by Yaskawa when assembling the cable. Select the appropriate type of connector in accordance with the motor application. The following two types of connectors are available for SGMGV servomotors.

- Standard Environment Connectors (Standard)
- Protective Structure IP67/European Safety Standards Compliant Connectors

Yaskawa does not specify which cables to use. Use appropriate cables for the connectors.

Selecting Cables (SGMGV-09 to -44)

● Standard Connectors

● Connector Configuration

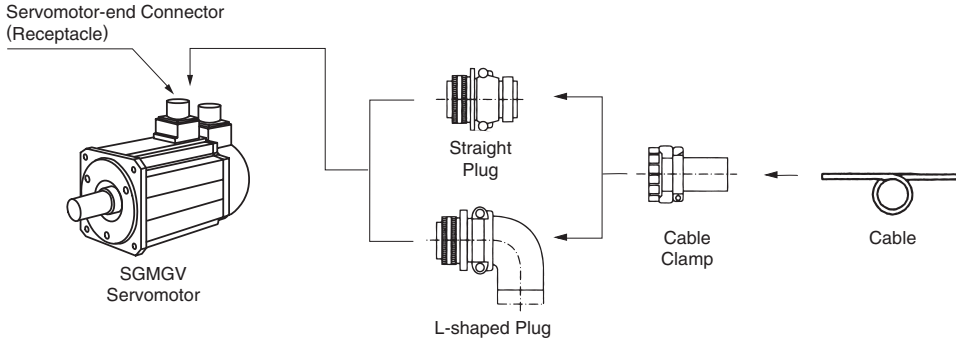

(1) Without Holding Brakes

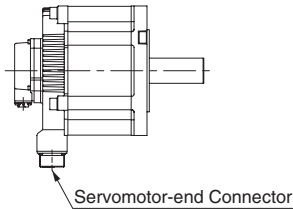

Servomotor-end Connector
For 0.85 to 4.4 kW

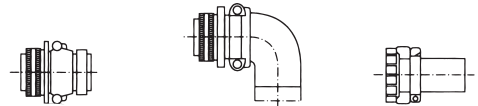

Capacity kW	Servomotor-end Connector (Receptacle)	Cable-end Connector (Not provided by Yaskawa)		
		Straight Plug	L-shaped Plug	Cable Clamp
0.85 1.3 1.8	MS3102A18-10P	MS3106B18-10S	MS3108B18-10S	MS3057-10A
2.9 4.4	MS3102A22-22P	MS3106B22-22S	MS3108B22-22S	MS3057-12A

Note: Servomotor-end connectors (receptacles) are RoHS-compliant. Contact the respective connector manufacturers for RoHS-compliant cable-end connectors (not provided by Yaskawa).

(2) With Holding Brakes

5.5 to 7.5 kW servomotors require servomotor-end connector and brake power supply connector. The servomotor-end connector is the same as is used for servomotors without holding brakes.

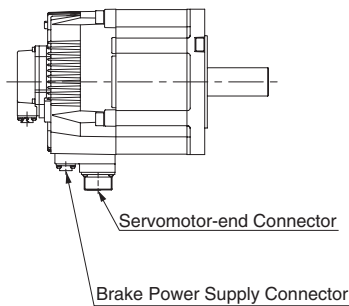

Brake Power Supply Connector
0.85 to 4.4 kW

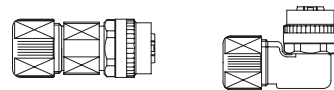

Capacity kW	Servomotor-end Connector (Receptacle)	Cable-end Connector (Not provided by Yaskawa)	
		Straight Plug	L-shaped Plug
0.85 to 4.4	CM10-R2P-D	CM10-SP2S-S-D Applicable Cable: 4.0 dia. to 6.0 dia.	CM10-AP2S-S-D Applicable Cable: 4.0 dia. to 6.0 dia.
		CM10-SP2S-M-D Applicable Cable: 6.0 dia. to 9.0 dia.	CM10-AP2S-M-D Applicable Cable: 6.0 dia. to 9.0 dia.
		CM10-SP2S-L-D Applicable Cable: 9.0 dia. to 11.6 dia.	CM10-AP2S-L-D Applicable Cable: 9.0 dia. to 11.6 dia.

Selecting Cables (SGMGV-09 to -44) mm

• Dimensional Drawings

(1) MS3106B□□-□□S : Straight Plug

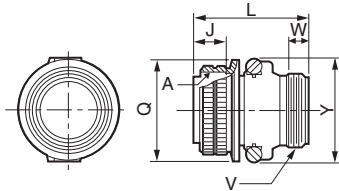

Shell Size	Joint Screw A	Length of Joint Portion J 0.12	Overall Length L max.	Outer Diameter of Joint Nut Q ⁺⁰ _{-0.38}	Cable Clamp Set Screw V	Effective Screw Length W min.	Maximum Width Y max.
18	1-1/8-18UNEF	18.26	52.37	34.13	1-20UNEF	9.53	42
22	1-3/8-18UNEF	18.26	55.57	40.48	1-3/16-18UNEF	9.53	50
32	2-18UNS	18.26	61.92	56.33	1-3/4-18UNS	11.13	66

(2) MS3108B□□-□□S : L-shaped Plug

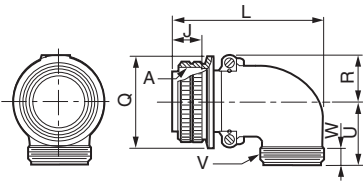

Shell Size	Joint Screw A	Length of Joint Portion J 0.12	Overall Length L max.	Outer Diameter of Joint Nut Q ⁺⁰ _{-0.38}	R 0.5	U 0.5	Cable Clamp Set Screw V	Effective Screw Length W min.
18	1-1/8-18UNEF	18.26	68.27	34.13	20.5	30.2	1-20UNEF	9.53
22	1-3/8-18UNEF	18.26	76.98	40.48	24.1	33.3	1-3/16-18UNEF	9.53
32	2-18UNS	18.26	95.25	56.33	32.8	44.4	1-3/4-18UNS	11.13

(3) MS3057-□□A : Cable Clamp with Rubber Bushing

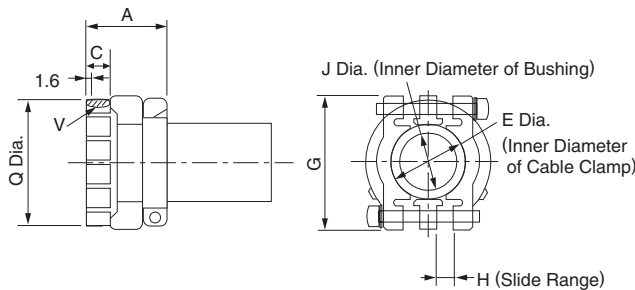

Cable Clamp Type	Applicable Connector Shell Size	Overall Length A 0.7	Effective Screw Length C	E Diameter	G 0.7	H	J Diameter	Set Screw V	Outer Diameter Q 0.7 Dia.	Attached Bushing
MS3057-10A	18	23.8	10.3	15.9	31.7	3.2	14.3	1-20UNEF	30.1	AN3420-10
MS3057-12A	20, 22	23.8	10.3	19	37.3	4	15.9	1-3/16-18UNEF	35.0	AN3420-12
MS3057-20A	32	27.8	11.9	31.7	51.6	6.3	23.8	1-3/4-18UNS	51.6	AN3420-20

Selecting Cables (SGMGV-09 to -44)

● Protective Structure IP67/European Safety Standards Compliant Connector

● Connector Configuration

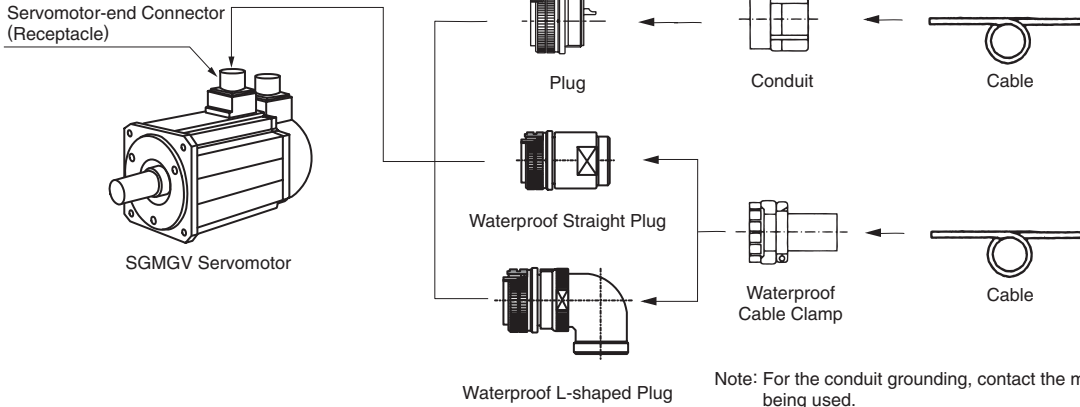

(1) Without Holding Brakes

Servomotor-end Connector
For 0.85 to 4.4kW

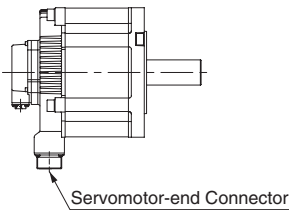
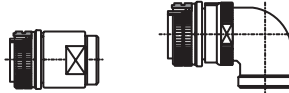

Capacity kW	Servomotor-end Connector (Receptacle)	Cable-end Connector (Not Provided by Yaskawa)			Applicable Cable Diameter (For Reference)	Manufacturer
		Straight Plug	L-shaped Plug	Cable Clamp		
0.85 1.3 1.8	CE05-2A18- 10PD-D	CE05-6A18- 10SD-D-BSS	CE05-8A18- 10SD-D-BAS	CE3057-10A-1-D	10.5 dia. to 14.1 dia.	DDK Ltd.
				CE3057-10A-2-D	8.5 dia. to 11.0 dia.	
				CE3057-10A-3-D	6.5 dia. to 8.7 dia.	
2.9 4.4	CE05-2A22- 22PD-D	CE05-6A22- 22SD-D-BSS	CE05-8A22- 22SD-D-BAS	CE3057-12A-1-D	12.5 dia. to 16.0 dia.	
				CE3057-12A-2-D	9.5 dia. to 13.0 dia.	
				CE3057-12A-3-D	6.8 dia. to 10.0 dia.	
				CE3057-12A-7-D	14.5 dia. to 17.0 dia.	

(2) With Holding Brakes

0.85 to 4.4 kW servomotors require servomotor-end connector and brake power supply connector.
The servomotor-end connector is the same as is used for servomotors without holding brakes.

Brake Power Supply Connector
0.85 to 4.4 kW

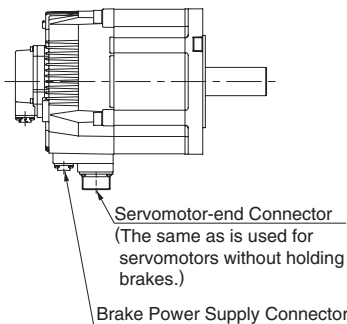
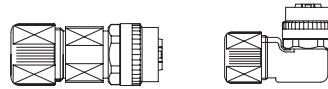

Capacity kW	Servomotor-end Connector (Receptacle)	Cable-end Connector (Not provided by Yaskawa)	
		Straight Plug	L-shaped Plug
0.85 to 4.4	CM10-R2P-D	CM10-SP2S-S-D Applicable Cable: 4.0 dia. to 6.0 dia.	CM10-AP2S-S-D Applicable Cable: 4.0 dia. to 6.0 dia.
		CM10-SP2S-M-D Applicable Cable: 6.0 dia. to 9.0 dia.	CM10-AP2S-M-D Applicable Cable: 6.0 dia. to 9.0 dia.
		CM10-SP2S-L-D Applicable Cable: 9.0 dia. to 11.6 dia.	CM10-AP2S-L-D Applicable Cable: 9.0 dia. to 11.6 dia.

Selecting Cables

● Encoder Cables (Max. length: 20 m)

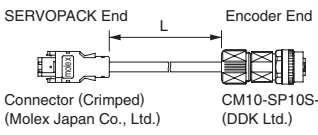
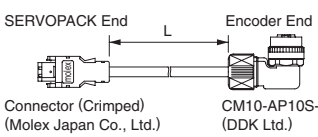
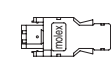
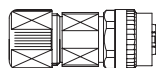
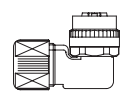
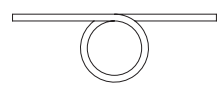
Name	Length (L)	Order No.		Specifications	Details	
		Standard Type	Flexible Type*			
Encoder Cable with Connectors (For Incremental Encoder)	3 m	JZSP-CVP01-03-E	JZSP-CVP11-03-E	 <p>SERVOPACK End L Encoder End</p> <p>Connector (Crimped) (Molex Japan Co., Ltd.) CM10-SP10S-※-D (DDK Ltd.)</p>	(1)	
	5 m	JZSP-CVP01-05-E	JZSP-CVP11-05-E			
	10 m	JZSP-CVP01-10-E	JZSP-CVP11-10-E			
	15 m	JZSP-CVP01-15-E	JZSP-CVP11-15-E			
	20 m	JZSP-CVP01-20-E	JZSP-CVP11-20-E			
	3 m	JZSP-CVP02-03-E	JZSP-CVP12-03-E			
	5 m	JZSP-CVP02-05-E	JZSP-CVP12-05-E			
	10 m	JZSP-CVP02-10-E	JZSP-CVP12-10-E			
Encoder Cable with Connectors (For Absolute Encoder, with a Battery Case)	15 m	JZSP-CVP02-15-E	JZSP-CVP12-15-E	 <p>SERVOPACK End L Encoder End</p> <p>Connector (Crimped) (Molex Japan Co., Ltd.) CM10-AP10S-※-D (DDK Ltd.)</p>	(2)	
	20 m	JZSP-CVP02-20-E	JZSP-CVP12-20-E			
	3 m	JZSP-CVP06-03-E	JZSP-CVP26-03-E			
	5 m	JZSP-CVP06-05-E	JZSP-CVP26-05-E			
	10 m	JZSP-CVP06-10-E	JZSP-CVP26-10-E			
	15 m	JZSP-CVP06-15-E	JZSP-CVP26-15-E			
	20 m	JZSP-CVP06-20-E	JZSP-CVP26-20-E			
	3 m	JZSP-CVP07-03-E	JZSP-CVP27-03-E			
5 m	JZSP-CVP07-05-E	JZSP-CVP27-05-E				
SERVOPACK-end Connector Kit		JZSP-CMP9-1-E		<p>Soldered</p> 	(3)	
	Encoder-end Connectors for Protective Structure IP67 (Connector on Servomotor: CM10-R10P-D)	CM10-SP10S-S-D		Straight plug		-
		Applicable Cable Diameter 4.0 dia. to 6.0 dia.				
		CM10-SP10S-M-D				
Applicable Cable Diameter 6.0 dia. to 9.0 dia.						
CM10-SP10S-L-D		L-shaped plug				
Applicable Cable Diameter 9.0 dia. to 11.6 dia.						
CM10-AP10S-S-D						
Applicable Cable Diameter 4.0 dia. to 6.0 dia.						
CM10-AP10S-M-D		Applicable Cable Diameter 6.0 dia. to 9.0 dia.				
CM10-AP10S-L-D						
Applicable Cable Diameter 9.0 dia. to 11.6 dia.						
Cables	3 m	JZSP-CMP09-03-E	JZSP-CMP39-03-E		(4)	
	5 m	JZSP-CMP09-05-E	JZSP-CMP39-05-E			
	10 m	JZSP-CMP09-10-E	JZSP-CMP39-10-E			
	15 m	JZSP-CMP09-15-E	JZSP-CMP39-15-E			
	20 m	JZSP-CMP09-20-E	JZSP-CMP39-20-E			

*: Use flexible cables for movable sections such as robot arms.

Selecting Cables

(1) Wiring Specifications for Cable with Connectors (For incremental encoder)

SERVOPACK End		Encoder (Servomotor) End	
Pin No.	Signal	Pin No.	Wire Color
5	PS	1	Light blue
6	/PS	2	Light blue/white
2	PG 0V	9	Black
1	PG 5V	4	Red
4	BAT (-)	5	White/orange
3	BAT (+)	6	Orange
Shell	FG	10	FG Shield Wire

Note: The signals BAT(+) and BAT(-) are used when using an absolute encoder.

(2) Wiring Specifications for Cable with Connectors (For absolute encoder, with a battery case)

SERVOPACK End		Encoder (Servomotor) End	
Pin No.	Signal	Pin No.	Wire Color
5	PS	1	Light blue
6	/PS	2	Light blue/white
2	PG 0V	9	Black
1	PG 5V	4	Red
4	BAT (-)	5	White/orange
3	BAT (+)	6	Orange
Shell	FG	10	FG Shield Wire

Battery Case	
Pin No.	Signal
2	BAT (-)
1	BAT (+)

(3) SERVOPACK-end Connector Kit Specifications

Items	Specifications
Order No.	JZSP-CMP9-1-E
Manufacturer	Molex Japan Co., Ltd.
Connector Model (For standard)	55100-0600 (soldered) or 55102-0600 (crimped)*
External Dimensions (Units: mm)	

Note: The mating connector model on SERVOPACK: 54280-800
The mating connector model on servomotor: 55102-0600

*: A crimp tool is required. The following crimp tools are applicable for the cables provided by Yaskawa. When using other wire sizes, contact the respective manufacturer for crimp tools.

Applicable crimp tool for Yaskawa's wire size: Hand Tool Model 57175-5000
Applicator Model 57175-3000

(4) Cable Specifications

Items	Standard Type	Flexible Type
Order No.*	JZSP-CMP09-□□-E	JZSP-CSP39-□□-E
Cable Length	20 m max.	
Specifications	UL20276 (Max. operating temperature: 80°C) AWG22×2C+AWG24×2P AWG22 (0.33 mm ²) Outer diameter of insulating sheath: 1.15 dia. AWG24 (0.20 mm ²) Outer diameter of insulating sheath: 1.09 dia.	UL20276 (Max. operating temperature: 80°C) AWG22×2C+AWG24×2P AWG22 (0.33 mm ²) Outer diameter of insulating sheath: 1.35 dia. AWG24 (0.20 mm ²) Outer diameter of insulating sheath: 1.21 dia.
Finished Dimensions	6.5 dia.	6.8 dia.
Internal Configuration and Lead Color		
Yaskawa Standards Specifications (Standard Length)	Cable length: 5 m, 10 m, 15 m, 20 m	

*: Specify the cable length in □□ of order no.
Example: JZSP-CMP09-05-E (5 m)

Selecting Cables

● Encoder Cables (For extending from 30 to 50 m)

Contact Yaskawa Controls Co., Ltd.

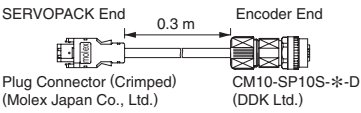
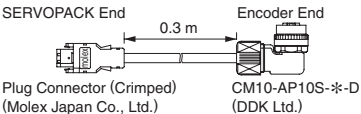
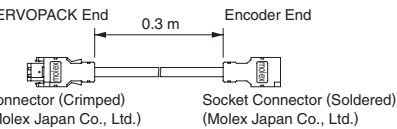
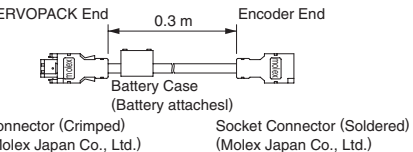
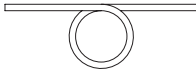
Name	Length	Order No.	Specifications	Details
① Encoder-end Cables (For incremental and absolute encoder)	0.3 m	JZSP-CVP01-E	 <p>SERVOPACK End 0.3 m Encoder End</p> <p>Plug Connector (Crimped) CM10-SP10S-?-D (Molex Japan Co., Ltd.) (DDK Ltd.)</p>	(1)
		JZSP-CVP02-E	 <p>SERVOPACK End 0.3 m Encoder End</p> <p>Plug Connector (Crimped) CM10-AP10S-?-D (Molex Japan Co., Ltd.) (DDK Ltd.)</p>	
② Cable with Connectors (For incremental and absolute encoder)	30 m	JZSP-UCMP00-30-E	 <p>SERVOPACK End 0.3 m Encoder End</p> <p>Connector (Crimped) Socket Connector (Soldered) (Molex Japan Co., Ltd.) (Molex Japan Co., Ltd.)</p>	(2)
	40 m	JZSP-UCMP00-40-E		
	50 m	JZSP-UCMP00-50-E		
③ Cable with a Battery Case (For absolute encoder)	0.3 m	JZSP-CMP12-E*	 <p>SERVOPACK End 0.3 m Encoder End</p> <p>Connector (Crimped) Socket Connector (Soldered) (Molex Japan Co., Ltd.) (Molex Japan Co., Ltd.)</p> <p>Battery Case (Battery attaches!)</p>	(3)
④ Relay Cables	30 m	JZSP-CMP19-30-E		(4)
	40 m	JZSP-CMP19-40-E		
	50 m	JZSP-CMP19-50-E		

*: When using an incremental encoder or using an absolute encoder with a battery connected to the host controller, no battery case is required.

Selecting Cables

(1) Wiring Specifications for Encoder-end Cable (For incremental and absolute encoder)

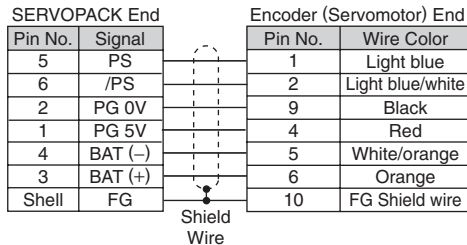

Note: The signals BAT(+) and BAT(-) are used when using an absolute encoder.

(2) Wiring Specifications for Cable with Connectors (For incremental and absolute encoder)

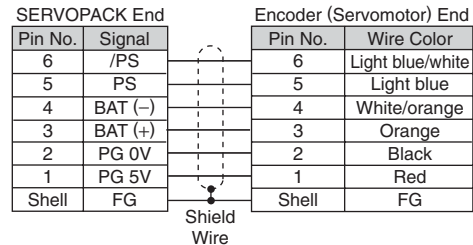

(3) Wiring Specifications for Cable with a Battery Case (For absolute encoder)

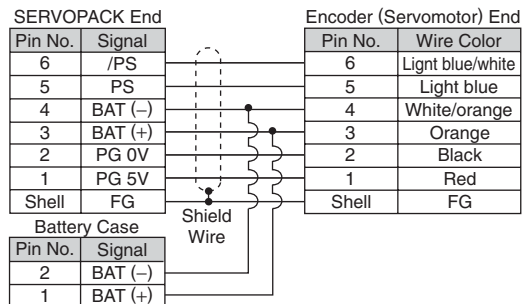

(4) Relay Encoder Cable Specifications

Item	Standard Type
Order No.*	JZSP-CMP19-□□-E
Cable Length	50 m max.
Specifications	UL20276 (Max. operating temperature: 80°C) AWG16×2C+AWG26×2P AWG16 (1.31 mm ²) Outer diameter of insulating sheath: 2.0 dia. mm AWG26 (0.13 mm ²) Outer diameter of insulating sheath: 0.91 dia. mm
Finished Dimensions	6.8 dia.
Internal Configuration and Lead Colors	
Yaskawa Standard Specifications (Standard Length)	Cable length: 30 m, 40 m, 50 m

*: Specify the cable length in □□ of order no.
Example: JZSP-CMP19-30-E (30 m)



Rotary Servomotor General Instructions

Precautions on Servomotor Installation

Servomotors can be installed either horizontally or vertically.

The service life of the servomotor will be shortened or unexpected problems will occur if the servomotor is installed incorrectly or in an inappropriate location. Always observe the following installation instructions.

CAUTION

Do not connect the servomotor directly to a commercial power line. This will damage the servomotor.

The servomotor cannot operate without the proper SERVOPACK.

(1) Installation Environment

Items	Condition
Ambient Temperature	0 to 40°C (no freezing)
Ambient Humidity	20% to 80%RH (no condensation)
Installation Site	<ul style="list-style-type: none"> • Free of corrosive or explosive gases. • Well-ventilated and free of dust and moisture. • Facilitates inspection and cleaning. • Elevation :1,000 m max. • Free of high magnetic field
Storage Environment	Store the servomotor in the following environment if it is stored with the power cable disconnected. Ambient temperature during storage: -20 to 60°C (no freezing) Ambient humidity during storage: 20% to 80%RH (no condensation)

(2) Protective Structure

The servomotor protective structure* is described table as follows.

Model	Without Gears	With Gears
SGMAV, SGMJV	IP65	IP55
SGMGV	IP67	—

*: Except through shaft section. The protective structure specifications can be satisfied only when using a specified cable.

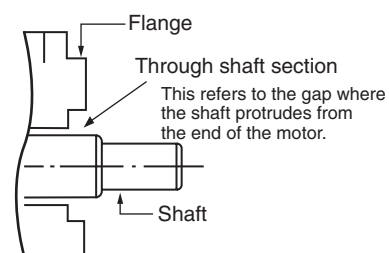

- Do not use servomotors in a location that is subject to oil. If the servomotor is used in a location that is subject to water or oil mist, order a servomotor with an oil seal to seal the through shaft section.

Precautions on Using Servomotor with Oil Seal:

- Put the oil surface under the oil seal lip.
- Use an oil seal in favorably lubricated condition.
- When using a servomotor with its shaft upward direction, be sure that oil will not stay in the oil seal lips.

(3) Orientation

- Servomotors can be installed either horizontally or vertically.

When installing servomotors vertically, make cable traps to keep out water. When mounting servomotors with the shaft up, take measures with the connected machine to prevent oil from getting into the servomotors through gear boxes etc.

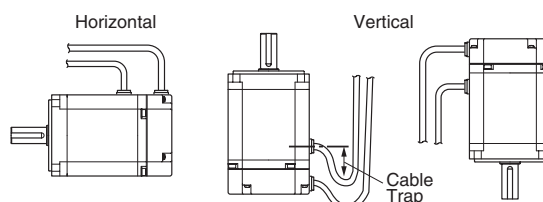

(4) Alignment

Align the shaft of the servomotor with the shaft of the equipment, and then couple the shafts.

IMPORTANT

- 1 Install the servomotor so that alignment accuracy falls within the following range. Vibration that will damage the bearings and encoders if the shafts are not properly aligned.

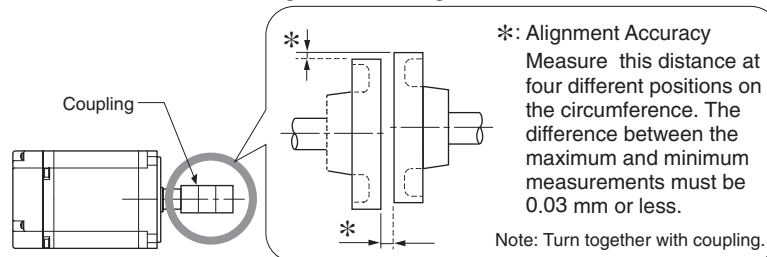

- 2 Do not allow any direct impact to the shafts when installing the couplings. Do not hit the area near encoders with a hammer etc., as impacts may damage the encoders.

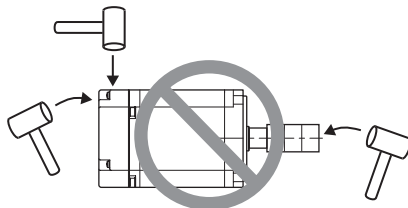

- 3 Before installation, thoroughly remove the anticorrosive paint from the end of the motor shaft. Only after removing the paint can servomotors be installed on the machines.

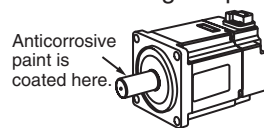

(5) Cable Stress

- Make sure there is no bending or tension on the cables themselves, the connections, or the cable lead inlets. Be especially careful to wire encoder cables so that they are not subject to stress because the core wires of encoder cables and main circuit cables are very thin at only 0.2 to 0.3 mm.

(6) Connectors

Observe the following precautions:

- When the connectors are connected to the motor, be sure to connect the end of motor main circuit cables before connecting the encoder cable's end. If the encoder cable's end is connected, the encoder may break because of the voltage differences between FG.
- Make sure there is no foreign matters such as dust and metal chips in the connector before connecting.
- Do not apply shock to resin connectors. Otherwise, they may be damaged.
- Make sure of the pin arrangement.
- Be sure not to apply stress on the connector, when using flexible cables. The connector may be damaged by stress.
- When handling a servomotor with its cables connected, hold the servomotor or the connectors and cables will be damaged.
- Fix the cable connector to SGMJV, SGMAV or SGMGV-03/-05 servomotors with screws. Refer to "Cable connections to SGMJV and SGMAV servomotors" or "Cable connections to SGMGV-03/-05 servomotors." Make sure that the connector is securely fixed with screws.
- If connectors are not connected properly, the protective structure specifications may not be satisfied.

Cable Connections to SGMJV and SGMJV Servomotors

Connect the main circuit cable and encoder cable to SGMJV or SGMJV servomotor in the following manner.

! CAUTION

Do not directly touch the connector pins provided with the servomotor. Particularly, the encoder may be damaged by static electricity, etc.

STEP1 Remove the protective tape and cap from the servomotor connector.

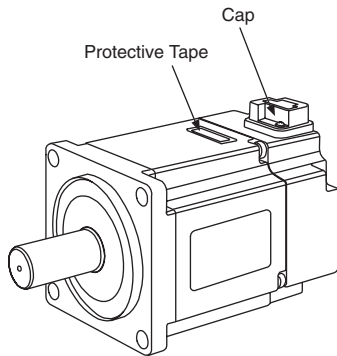

STEP2 Mount the cable connector on the servomotor and fix it with screws as shown in the figure below.

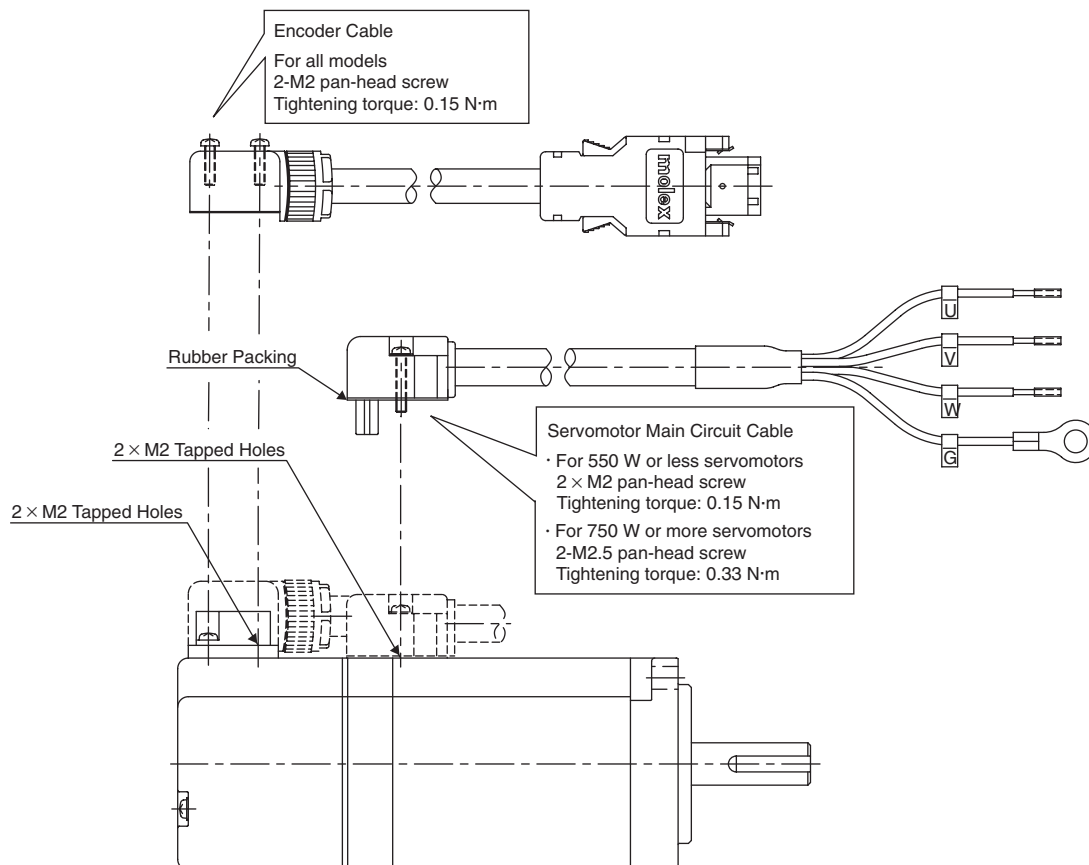

IMPORTANT

- First, connect the servomotor to the servomotor main circuit cable end.
- Do not remove the rubber packing. Mount the connector so that the rubber packing is seated properly.
If the rubber packing is not seated properly, the requirements for the protective structure specifications may not be met.

Cable Connections to SGMGV-03/-05 Servomotors

Connect the main circuit cable and encoder cable to SGMGV-03/-05 servomotor in the following manner.

CAUTION

Do not directly touch the connector pins provided with the servomotor. Particularly, the encoder may be damaged by static electricity, etc.

STEP1 Remove the protective cap from the servomotor connector.

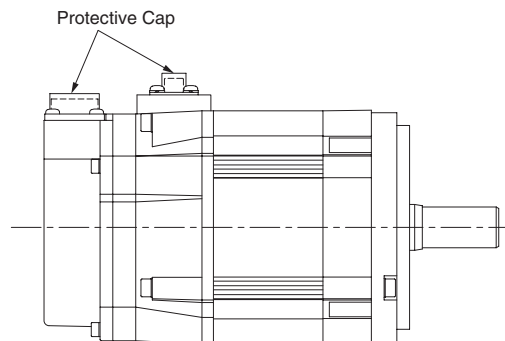

STEP2 Mount the cable connector on the servomotor and fix it with screws as shown in the figure below.

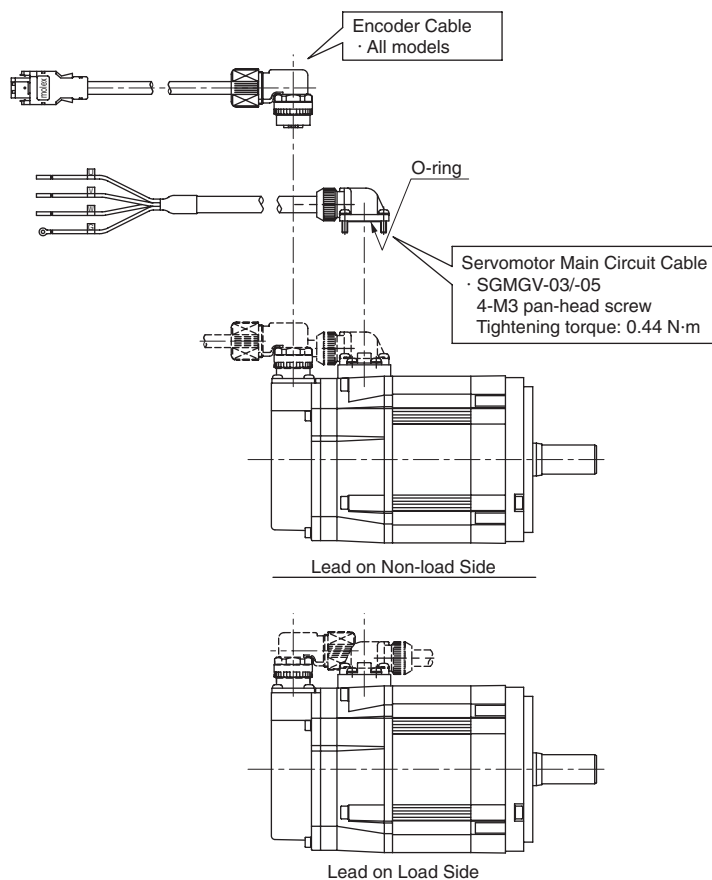

IMPORTANT

- First, connect the servomotor to the servomotor main circuit cable end.
- Do not remove the O-ring. Mount the connector so that the O-ring is seated properly. If the O-ring is not seated properly, the requirements for the protective structure specifications may not be met.

Mechanical Specifications

● Mechanical Tolerance T.I.R. (Total Indicator Reading)

The following figure shows tolerances for the servomotor's output shaft and installation area. For more details on tolerances, refer to the external dimensions of the individual servomotor.

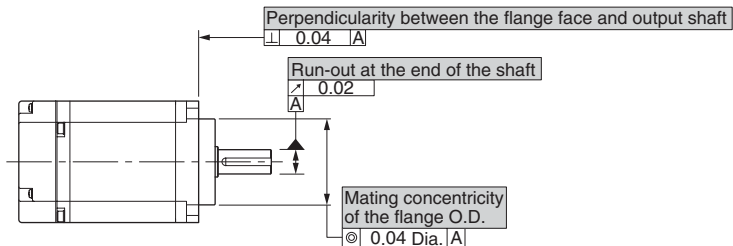

● Direction of Servomotor Rotation

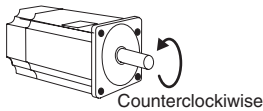

Positive rotation of the servomotor without a gear is counterclockwise when viewed from the load. Refer to "Ratings and Specifications" for each series regarding positive rotation of the servomotor with a gear. The direction of rotation can be reversed by changing the SERVOPACK parameters.

● Impact Resistance

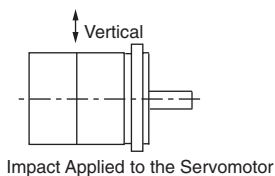

Mount the servomotor with the axis horizontal. The servomotor will withstand the following vertical impacts:

- Impact Acceleration: 490 m/s²
- Impact occurrences: 2

● Vibration Resistance

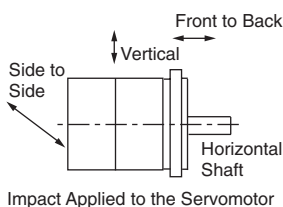

Mount the servomotor with the axis horizontal. The servomotor will withstand the following vibration acceleration in three directions: Vertical, side to side, and front to back.

Servomotor Model	Vibration Acceleration at Flange
SGMJV, SGMAV	49 m/s ²
SGMGV	49 m/s ² (Front to back direction: 24.5 m/s ²)

IMPORTANT

The amount of vibration the servomotor endures will vary depending on the application. Check the vibration acceleration being applied to your servomotor for each application.

● Vibration Class

The vibration class for the SGM□V servomotors at rated motor speed is as follows:

- Vibration Class: V15

(A vibration class of V15 indicates a total vibration amplitude of 15 μm maximum on the servomotor during rated rotation.)

Rotor Moment of Inertia

Small-capacity servomotors come in a medium inertia series "SGMJV servomotor" and low inertia series "SGMAV servomotor." The rotor moment of inertia of SGMJV servomotor is twice as large as that of SGMAV. Select servomotors based on the specifications of your devices, such as load moment of inertia or machine rigidity.

- When the rotor moment of inertia is large:

Servomotors are capable of corresponding load changes. This has the benefit of reducing settling time and speed ripple. This should also improve control stability of machines with low rigidity.

- When mounting the servomotor with low rotor moment of inertia to devices with load moment of inertia:

Acceleration/deceleration torque increases and effective load ratio increases. Check the effective load ratio when you select motor capacity.

Servomotor Heating Conditions

The motor rated specifications are continuous allowable values at an ambient temperature of 40°C when servomotors are installed with heat sinks. When the motor is mounted on a small surface, the motor temperature may rise considerably because of the limited heat radiating abilities of the surface. See the following graph for the relation between heat sink size and derating (derating ratio).

IMPORTANT The actual temperature rise depends on how the heat sink (servomotor mounting section) is fixed on the installation surface, what material is used for the motor mounting section, and motor speed. Always check the actual motor temperature.

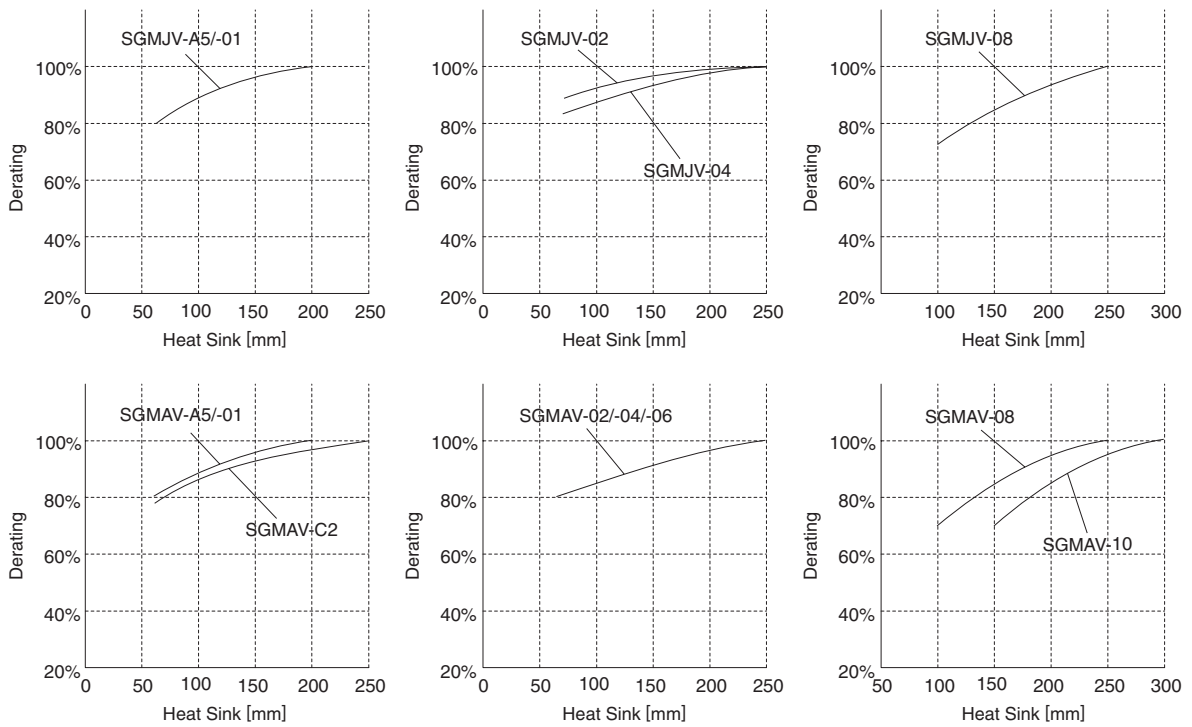

Holding Brake Delay Time

Holding brakes have motion delay time that varies depending on when the brake is open and when the brake is operating. The following table shows the brake delay time of each servomotor.

IMPORTANT Make sure the holding brake delay time is correct for your servomotor.

- Example, switching the holding brakes on the DC side

Model	Voltage	Brake Open Time ms	Brake Operation Time ms
SGMAV-A5 to 04	24 V	60	100
SGMAV-06 to 10		80	100
SGMJV-A5 to 04	24 V	60	100
SGMJV-08		80	100
SGMGV-03, 05	24 V, 90 V	100	80
SGMGV-09, 13, 20		100	80
SGMGV-30, 44		170	100 (24 V) , 80 (90 V)

Cables

● Standard Cables

Standard servomotor main circuit cables, encoder cables, and relay cables cannot be used in cases where high flexibility is needed, as when the cables themselves move or are twisted or turned.

R15 min. is recommended for the bending radius of standard cables. Use flexible cables for flexible applications.

● Flexible Cables

(1) Life of Flexible Cable

The flexible cable supports 10,000,000 or more operations of bending life with the recommended bending radius $R = 90$ mm under the following test conditions.

● Conditions

- 1 Repeat moving one end of the cable forward and backward for 320 mm using the test equipment shown in the following figure.
- 2 Connect the lead wires in parallel, and count the number of cable return motion times until a lead wire is disconnected. Note that one reciprocation is counted as one test.

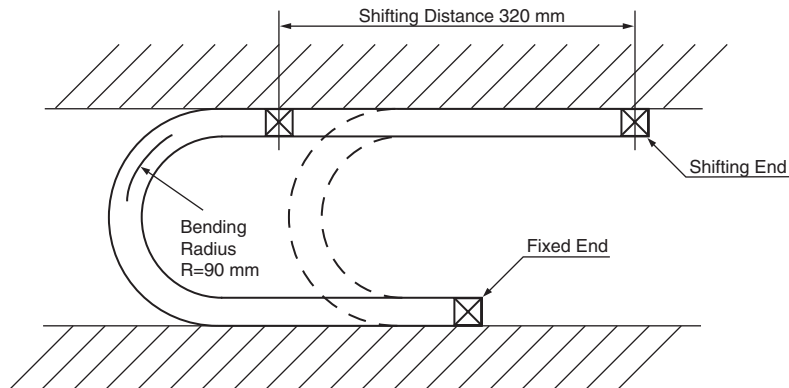

Notes: 1 The life of flexible cable differs largely depending on the amount of mechanical shocks, mounting to the cable, and fixing methods. The life of flexible cable is limited under the specified conditions.

2 The life of flexible cable indicates the number of bending times in which lead wires are electrically conducted and by which no cracks and damages that affects the performance of cable sheathing are caused. Disconnecting the shield wire is not taken into account.

(2) Wiring Precautions

Even if the recommended bending radius R is followed in the mechanical design, incorrect wiring may cause the early disconnection. Observe the following precautions when wiring.

(a) Cable twisting

Straighten the flexible cables wiring.

Twisted cables cause the early disconnection. Check the indication on the cable surface to make sure that the cable is not twisted.

(b) Fixing method

Do not fix the moving points of the flexible cable, or stress on the fixed points may cause early disconnection.

Fix the cable at the minimum number of points. Do not put stress on the servomotor-end and SERVOPACK-end connectors.

(c) Cable length

If the cable length is too long, it may result the cable sagging. If the cable length is too short, excessive tension on the fixed points will cause the early disconnection. Use a flexible cable with the optimum length.

(d) Interference between cables

Avoid interference between cables.

Interference limits the motion of flexible cable, which causes early disconnection. Keep enough distance between cables, or provide a partition when wiring.

Direct Drive Servomotors

SGMCS

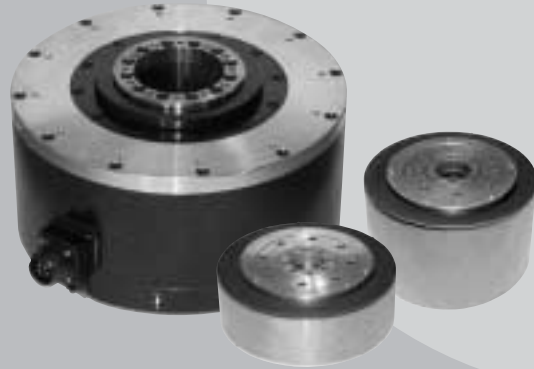

Model Designations

SGMCS - 02 B 3 C 1 1

Direct Drive Servomotor SGMCS

1st+2nd digits 3rd digit 4th digit 5th digit 6th digit 7th digit

1st+2nd digits Rated Torque

Code	Rated Torque
02	2.0 N·m
04	4.0 N·m
05	5.0 N·m
07	7.0 N·m
08	8.0 N·m
10	10 N·m
14	14 N·m
16	16 N·m
17	17 N·m
25	25 N·m
35	35 N·m

3th digit Motor Outer Diameter

Code	Motor Outer Diameter
B	135 dia. mm
C	175 dia. mm
D	230 dia. mm
E	290 dia. mm

4th digit Encoder Specifications

Code	Specifications
3	20-bit absolute (without multiturn data) (standard)
D	20-bit incremental (option)

5th digit Design Revision Order

Code	Specifications
B	Model of servomotor outer diameter code E
C	Model of servomotor outer diameter code B, C, D

6th digit Flange Specifications

Code	Flange Specifications		Motor Outer Diameter Code (3rd digit)			
	Specifications	Mounted Side	B	C	D	E
1	C-face	Non-load side	○	○	○	○
4	C-face	Non-load side (with cable on side)	○	○	○	○

○ : Applicable Model

7th digit Brake Specifications

Code	Brake Specifications
1	Without brake

Features

- Directly coupled to a load without a mechanical transmission such as a gear.
- Powerful and smooth operation throughout the speed range from low to high.
(Instantaneous peak torque: 6 to 600 N·m
maximum speed: 250 to 500 min⁻¹)
- High-resolution, 20-bit encoder for highly precise indexing.
- Easy wiring and piping with the hollow structure.

Application Examples

- Semiconductor equipment
- LCD manufacturing equipment
- Units for inspection and testing
- Electronic parts assembling machines
- IC handlers
- Inspection units for integrated circuits
- Automated machines
- Robots

Rated Torque / Peak Torque

Outer Diameter 135 mm, Inner Diameter 20 mm

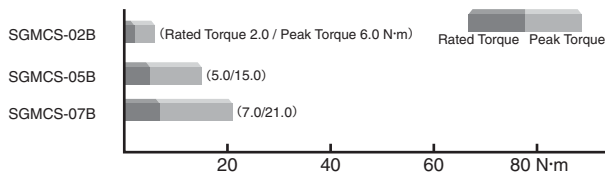

Outer Diameter 175 mm, Inner Diameter 35 mm

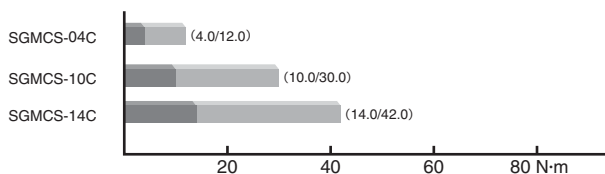

Outer Diameter 230 mm, Inner Diameter 60 mm

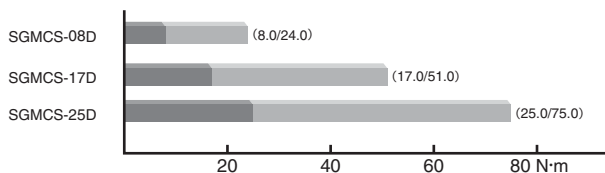

Outer Diameter 290 mm, Inner Diameter 75 mm

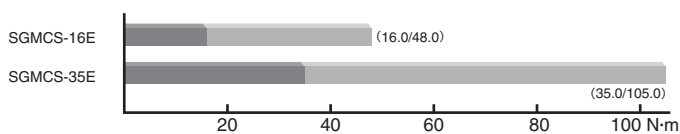

Ratings and Specifications

Time Rating: Continuous

Vibration Class: V15

Insulation Resistance: 500 VDC, 10 MΩ min.

Ambient Temperature: 0 to 40°C

Excitation: Permanent magnet

Mounting: Flange method

Thermal Class: A

Withstand Voltage: 1500 VAC for one minute

Enclosure: Totally enclosed, self-cooled, IP42 (except for gaps on the rotating section of the shaft)

Ambient Humidity: 20% to 80% (no condensation)

Drive Method: Direct drive

Voltage		200 V										
Servomotor Model SGMCS-□□		02B□C	05B□C	07B□C	04C□C	10C□C	14C□C	08D□C	17D□C	25D□C	16E□C	35E□C
Rated Output*1	W	42	105	147	84	209	293	168	356	393	335	550
Rated Torque*1, *2	N·m	2.0	5.0	7.0	4.0	10.0	14.0	8.0	17.0	25.0	16.0	35.0
Instantaneous Peak Torque*1	N·m	6.0	15.0	21.0	12.0	30.0	42.0	24.0	51.0	75.0	48.0	105
Stall Torque*1	N·m	2.05	5.15	7.32	4.09	10.1	14.2	8.64	19.2	27.2	17.6	38.3
Rated Current*1	Arms	1.8	1.7	1.4	2.2	2.2	2.8	1.9	2.3	2.4	3.3	3.5
Instantaneous Max. Current*1	Arms	5.4	5.1	4.1	7.0	7.0	8.3	5.6	6.9	7.2	9.4	10.0
Rated Speed*1	min ⁻¹	200			200			200		150	200	150
Max. Speed*1	min ⁻¹	500			500	400	300	500	350	250	500	250
Torque Constant	N·m/Arms	1.18	3.17	5.44	2.04	5.05	5.39	5.1	8.48	12.1	5.58	11.1
Rotor Moment of Inertia	kg·m ² ×10 ⁻⁴	28	51	77	77	140	220	285	510	750	930	1430
Rated Power Rate*1	kW/s	1.4	4.9	6.4	2.1	7.1	8.9	2.2	5.7	8.3	2.75	8.57
Rated Angular Acceleration*1	rad/s ²	710	980	910	520	710	640	280	330	330	170	240
Absolute Accuracy	second	±15			±15			±15		±15		
Repeatability	second	±1.3			±1.3			±1.3		±1.3		
Applicable SERVOPACK	SGDV-	2R8A			2R8A			2R8A		5R5A		

*1: These items and torque-motor speed characteristics quoted in combination with an SGD V SERVOPACK are at an armature winding temperature of 100°C. Other values quoted at 20°C.

*2: Rated torques are continuous allowable torque values at 40°C with a steel heat sink attached.

Heat sink: SGMCS-□□B : 350 mm × 350 mm × 12 mm SGMCS-□□C : 450 mm × 450 mm × 12 mm

SGMCS-□□D : 550 mm × 550 mm × 12 mm SGMCS-□□E : 650 mm × 650 mm × 12 mm

Notes: 1 SGMCS servomotor with holding brake is not available.

2 For the bearings used in SGMCS servomotors, loss varies according to the bearing temperature. At low temperatures, the amount of heat loss will be large.

Torque-Motor Speed Characteristics

□A : Continuous Duty Zone □B : Intermittent Duty Zone

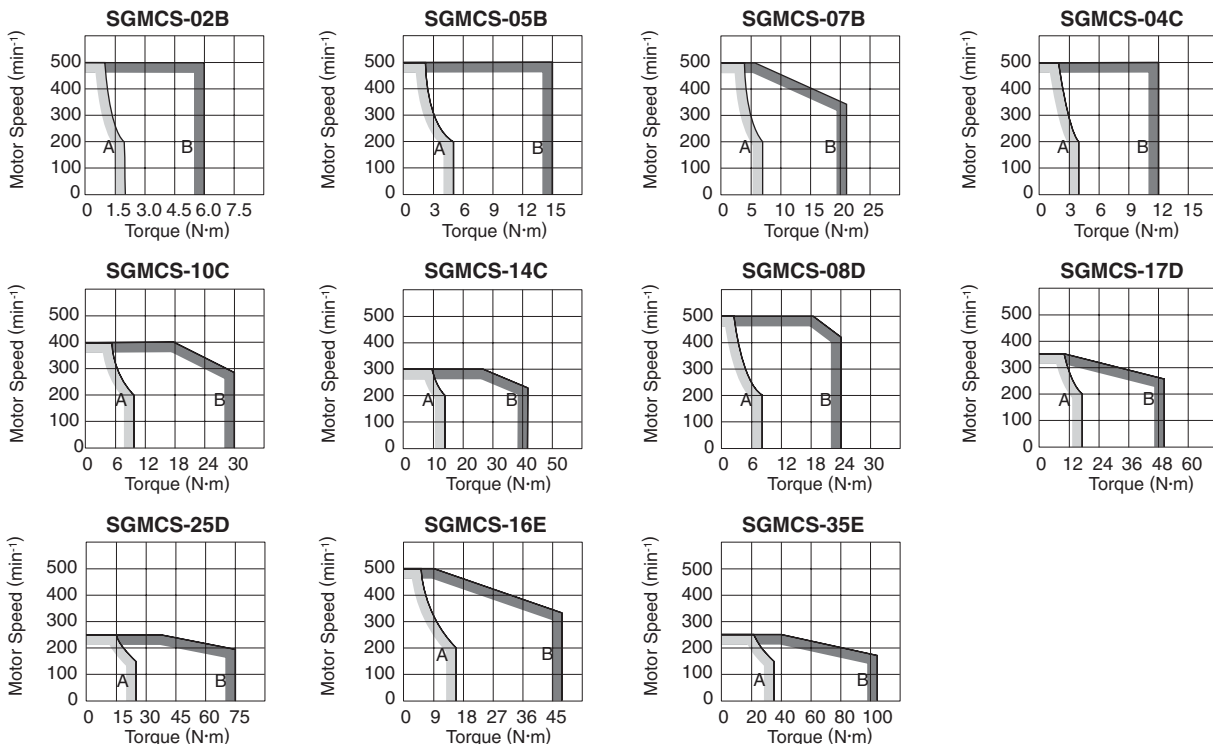

Ratings and Specifications

● **Load Moment of Inertia and Motor Speed**

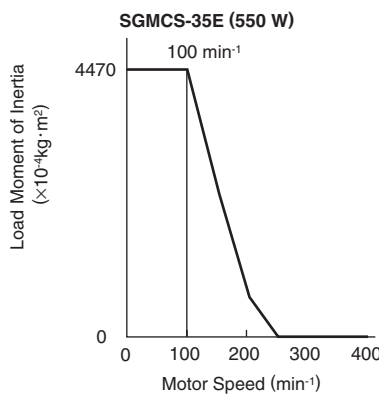
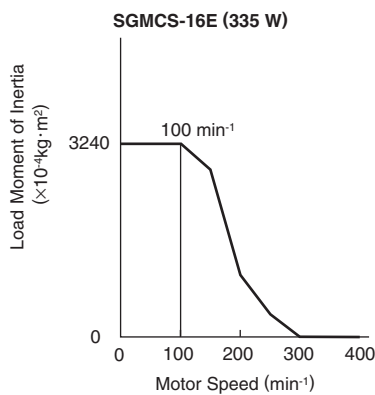
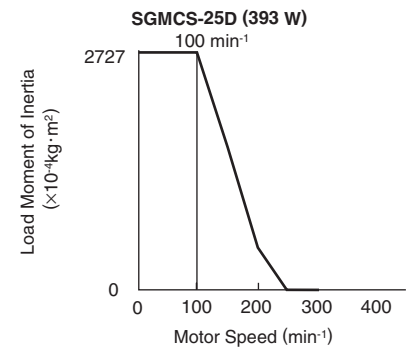
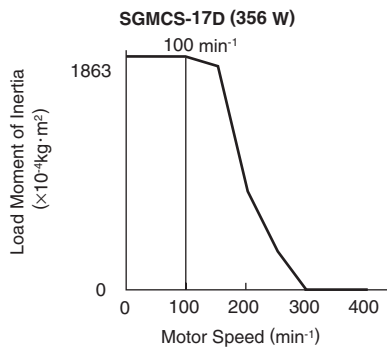
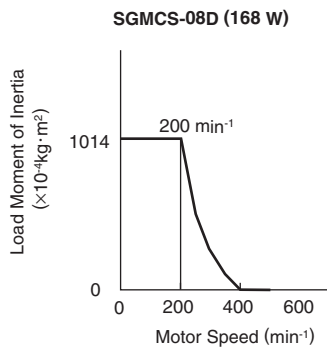
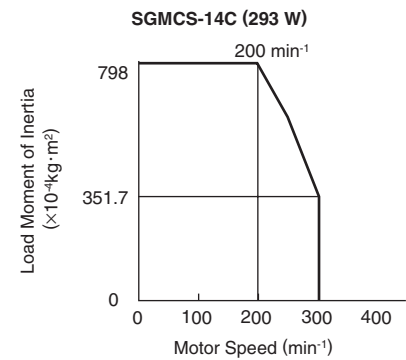
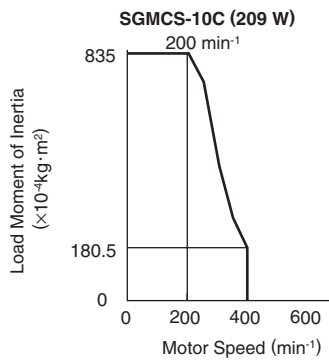
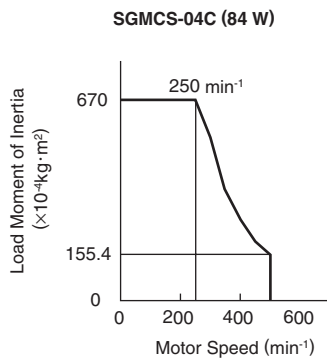
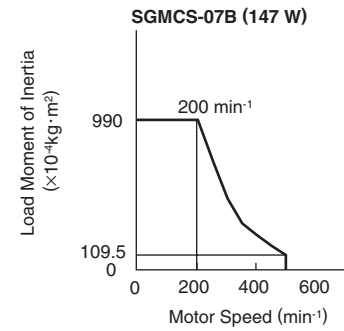
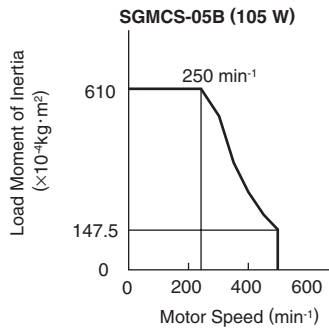
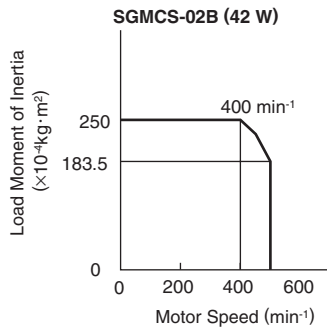

● **Allowable Load Moment of Inertia at the Motor Shaft**

Servomotor Model	Rated Torque N·m	Allowable Load Moment of Inertia (Rotor Moment of Inertia Ratio)
SGMCS	2.0, 4.0, 5.0, 7.0	10 times
	10.0	5 times
	8.0, 14.0, 16.0, 17.0, 25.0, 35.0	3 times

Mechanical Specifications

● Allowable Loads

The loads applied while a servomotor is running are roughly classified in the following patterns. Design the machine so that the thrust load and moment load will not exceed the values in the table.

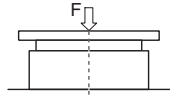

Where F is external force,
Thrust load: $F_a = F + \text{Load mass}$
Moment load: $M = 0$

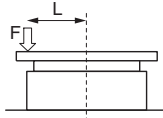

Where F is external force,
Thrust load: $F_a = F + \text{Load mass}$
Moment load: $M = F \times L$

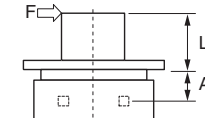

Where F is external force,
Thrust load: $F_a = \text{Load mass}$
Moment load: $M = F \times (L + A)$

(See the table below for the dimension A of each servomotor model.)

Servomotor Model SGMCS-□	02B	05B	07B	04C	10C	14C	08D	17D	25D	16E	35E
Dimension A mm	0			0			0			0	
Allowable Thrust Load (F_a) N	1500			3300			4000			11000	
Allowable Moment Load (M) N·m	40	50	64	70	75	90	93	103	135	250	320

Note: SGMCS-02B to -35E servomotors, set dimensions A to 0 (zero).

● Mechanical Tolerance

The following table shows tolerances for the servomotor's output shaft and installation area. See the dimensional drawing of the individual servomotor for more details on tolerances.

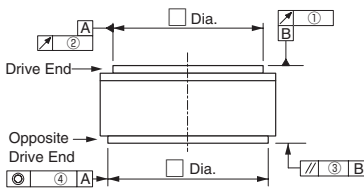

Tolerance T.I.R. (Total Indicator Reading) Units: mm	Servomotor Model SGMCS-										
	02B	05B	07B	04C	10C	14C	08D	17D	25D	16E	35E
① Run-out of the Surface of the Shaft	0.02			0.02			0.02			0.02	
② Run-out at the End of the Shaft	0.04			0.04			0.04			0.04	
③ Perpendicularity between the Flange Face and Output Shaft	0.07			0.07			0.08			0.08	
④ Coaxiality of Output Axis and Mounting Socket Joint	0.07			0.07			0.08			0.08	

● Direction of Rotation

Positive rotation of the servomotor is counterclockwise when viewed from the load.

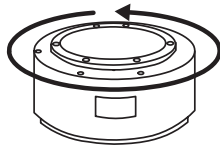

● Impact Resistance

Mount the servomotor with the axis horizontal. The servomotor will withstand the following vertical impacts:

- Impact Acceleration: 490 m/s²
- Number of Impacts: 2

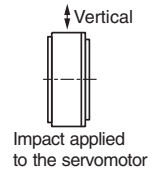

● Vibration Resistance

Mount the servomotor with the axis horizontal. The servomotor will withstand the following vibration acceleration in three directions: Vertical, side to side, and front to back.

Vibration Acceleration at Flange
49 m/s ²

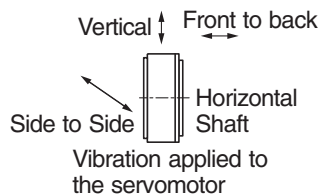

● Vibration Class

The vibration class at rated motor speed is 15 μm or below. (A vibration class of 15 μm or below indicates a total vibration amplitude of 15 μm maximum on the servomotor during rated rotation.)

● Enclosure

Enclosure
IP42 (gaps on the rotating section of the shaft)

External Dimensions Units: mm

(1) Rated Torque 2.0 to 7.0 N·m (Outer Diameter 135 mm, Inner Diameter 20 mm)

• Applicable Flange : 1

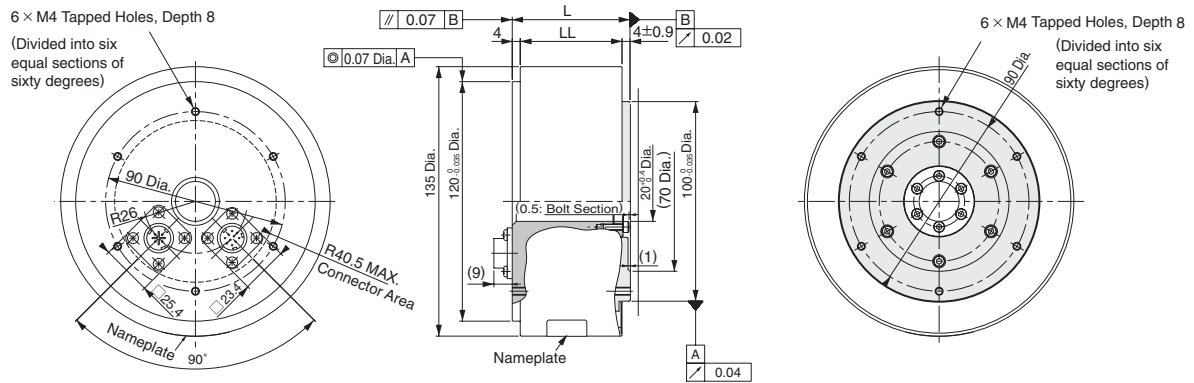

Model SGMCS-	L	LL	Approx. Mass kg
02B□C11	59	51	4.8
05B□C11	88	80	5.8
07B□C11	128	120	8.2

• Applicable Flange : 4

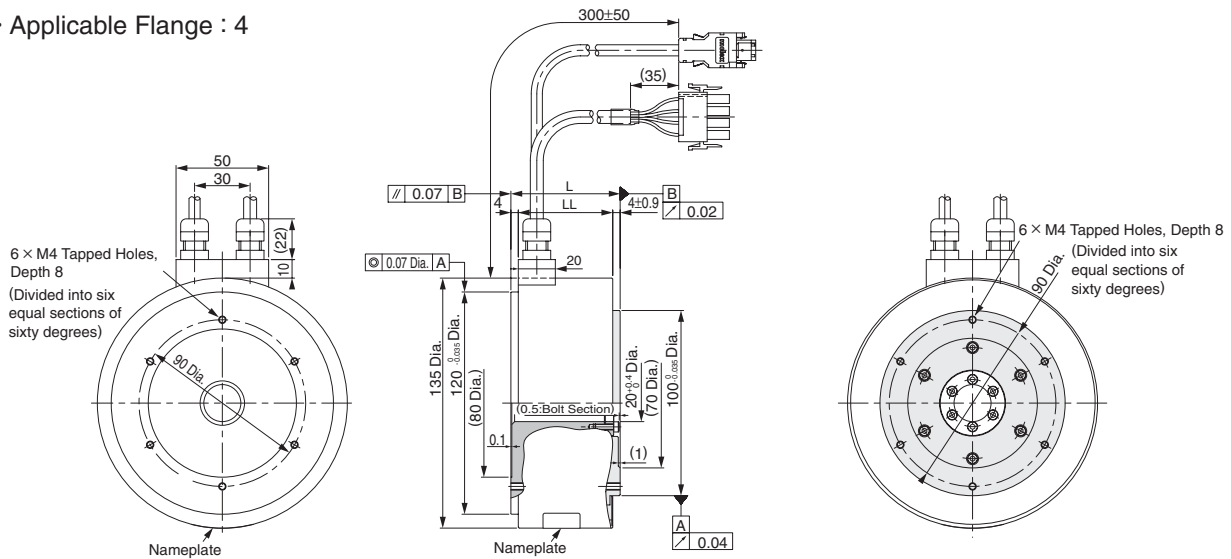

Model SGMCS-	L	LL	Approx. Mass kg
02B□C41	59	51	4.8
05B□C41	88	80	5.8
07B□C41	128	120	8.2

● Connectors on Servomotor
Servomotor-end Connector Specifications

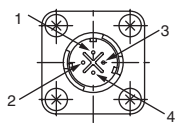

Model: JN1AS04MK2
Manufacturer: Japan Aviation Electronics Industry, Ltd.
Applicable plug: JN1DS04FK1
(Provided by the customer.)

1	Phase U	Red
2	Phase V	White
3	Phase W	Blue
4	FG (Frame ground)	Green (yellow)

Encoder-end Connector Specifications

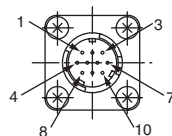

Model: JN1AS10ML1
Manufacturer: Japan Aviation Electronics Industry, Ltd.
Applicable plug: JN1DS10SL1
(Provided by the customer.)

1	PS	Light blue	6	-	-
2	/PS	Light blue/ white	7	FG (Frame ground)	Shield
3	-	-	8	-	-
4	PG5V	Red	9	PG0V	Black
5	-	-	10	-	-

External Dimensions Units: mm

(2) Rated Torque 4.0 to 14.0 N·m (Outer Diameter 175 mm, Inner Diameter 35 mm)

• Applicable Flange: 1

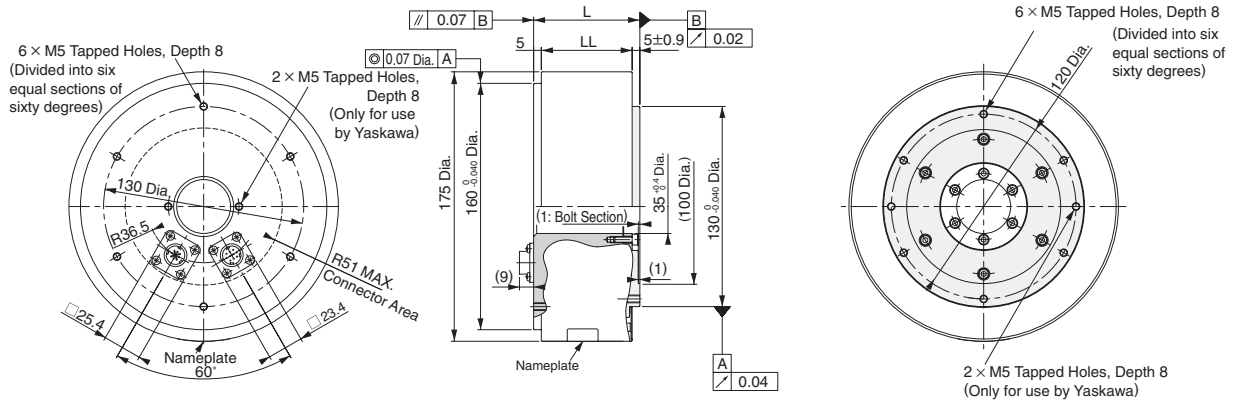

Model SGMCS-	L	LL	Approx. Mass kg
04C□C11	69	59	7.2
10C□C11	90	80	10.2
14C□C11	130	120	14.2

• Applicable Flange : 4

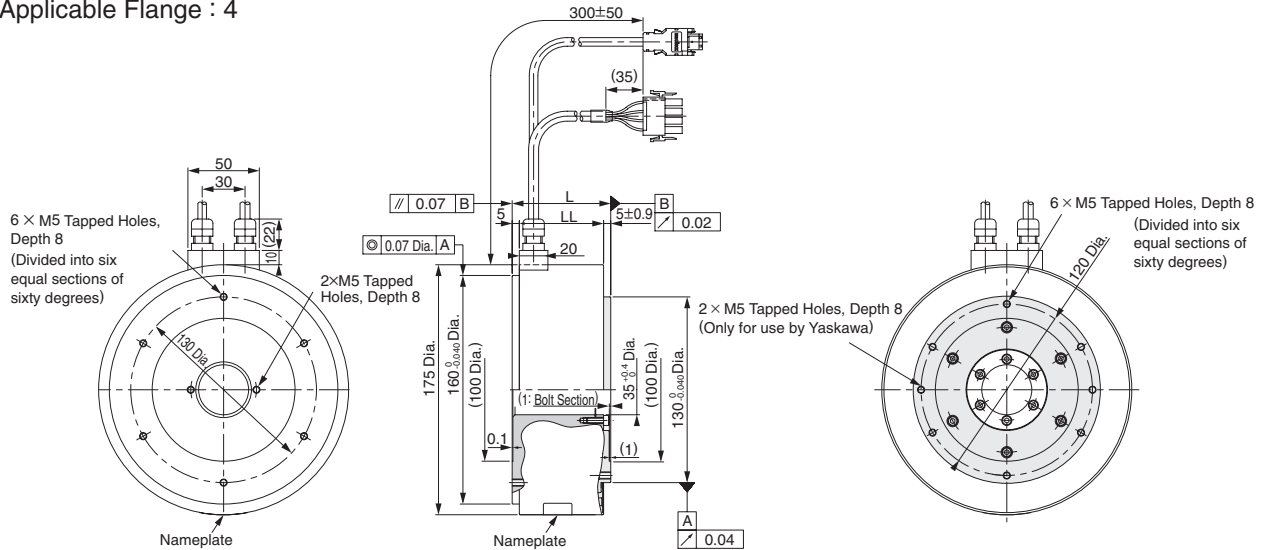

Model SGMCS-	L	LL	Approx. Mass kg
04C□C41	69	59	7.2
10C□C41	90	80	10.2
14C□C41	130	120	14.2

● Connectors on Servomotor (Applicable Flange : 4)

Servomotor-end Connector Specifications

- Model
- Plug : 350779-1
 - Pin : 350561-3 or 350690-3 (No.1 to 3)
 - Ground pin : 350654-1 or 350669-1 (No.4)
- Manufacturer: Tyco Electronics AMP K.K.
Applicable plug
- Cap : 350780-1
 - Socket : 350570-3 or 350689-3

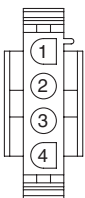

1	Phase U	Red
2	Phase V	White
3	Phase W	Blue
4	FG (Frame ground)	Green (yellow)

Encoder-end Connector Specifications

- Model : 55102-0600
Manufacturer : Molex Japan Co., Ltd
Applicable plug : 54280-0600

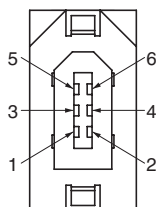

1	PG5V	Red
2	PG0V	Black
3	-	-
4	-	-
5	PS	Light blue
6	/PS	Light blue/white
Connector Case	FG (Frame ground)	Shield

External Dimensions Units: mm

(3) Rated Torque 8.0 to 25.0 N·m (Outer Diameter 230 mm, Inner Diameter 60 mm)

• Applicable Flange : 1

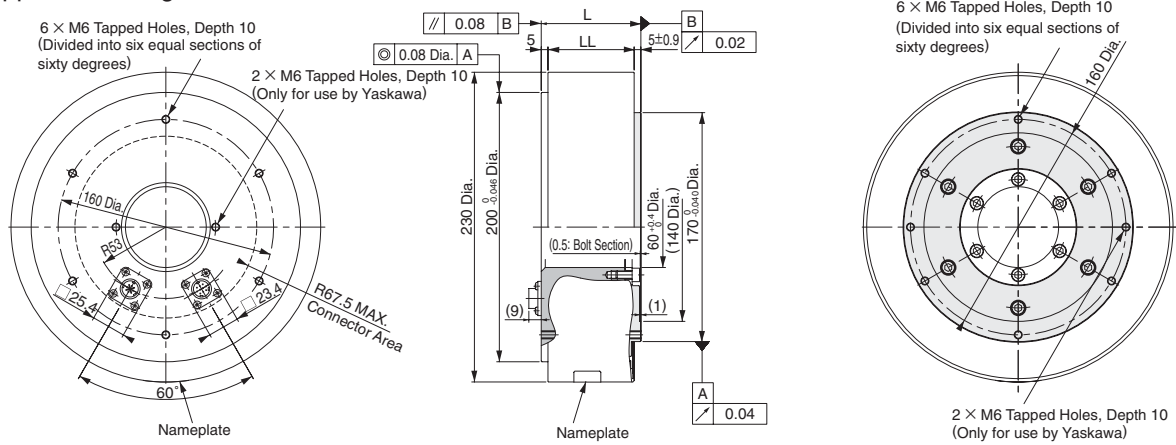

Model SGMCS-	L	LL	Approx. Mass kg
08D□C11	74	64	14.0
17D□C11	110	100	22.0
25D□C11	160	150	29.7

• Applicable Flange : 4

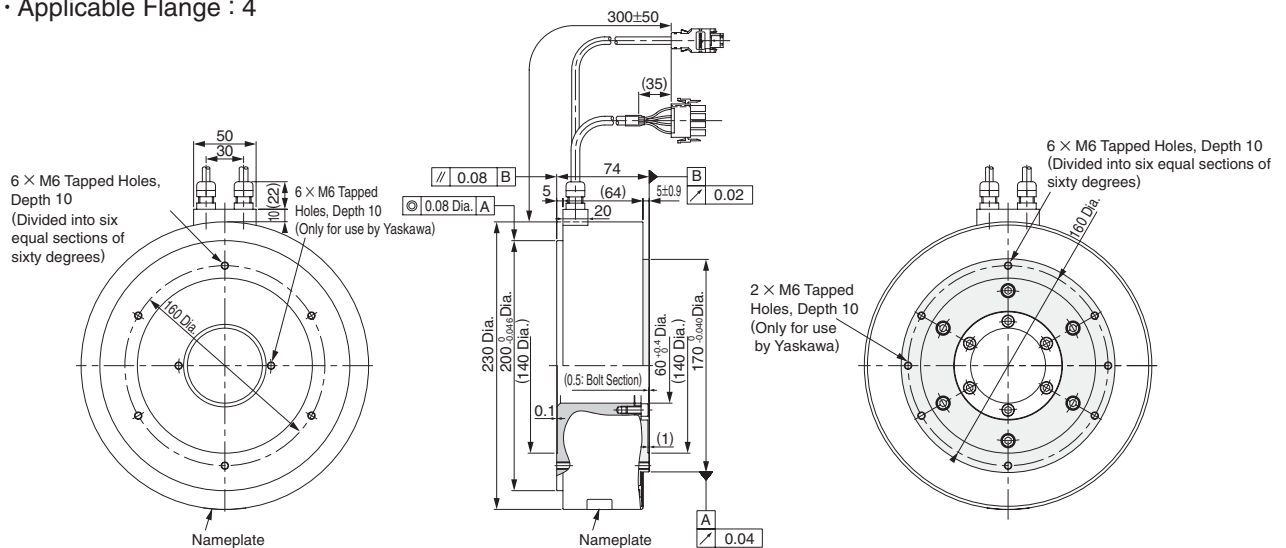

Model SGMCS-	L	LL	Approx. Mass kg
08D□C41	74	64	14.0
17D□C41	110	100	22.0
25D□C41	160	150	29.7

External Dimensions Units: mm

(4) Rated Torque 16.0 to 35.0 N·m (Outer Diameter 290 mm, Inner Diameter 75 mm)

• Applicable Flange : 1

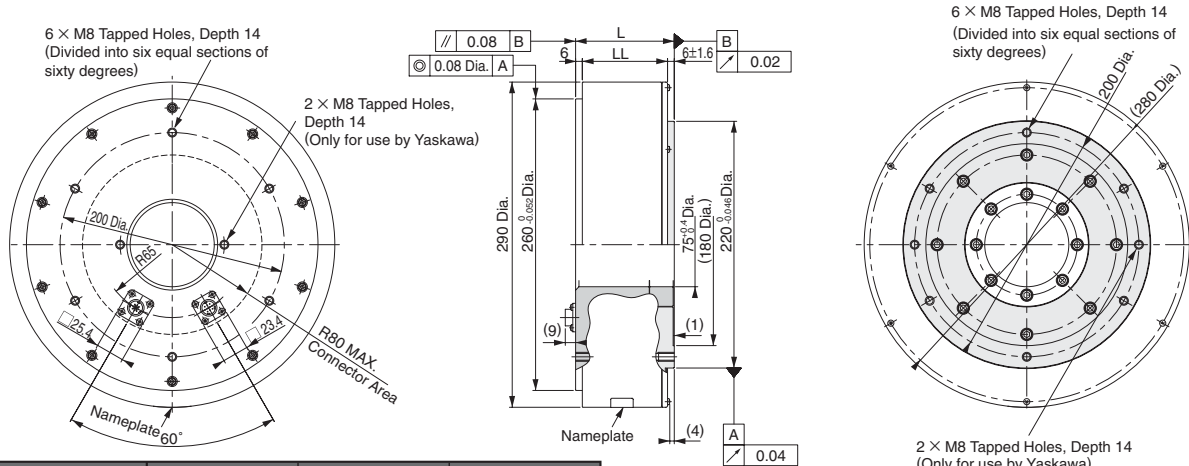

Model SGMCS-	L	LL	Approx. Mass kg
16E□B11	88	76	26.0
35E□B11	112	100	34.0

• Applicable Flange : 4

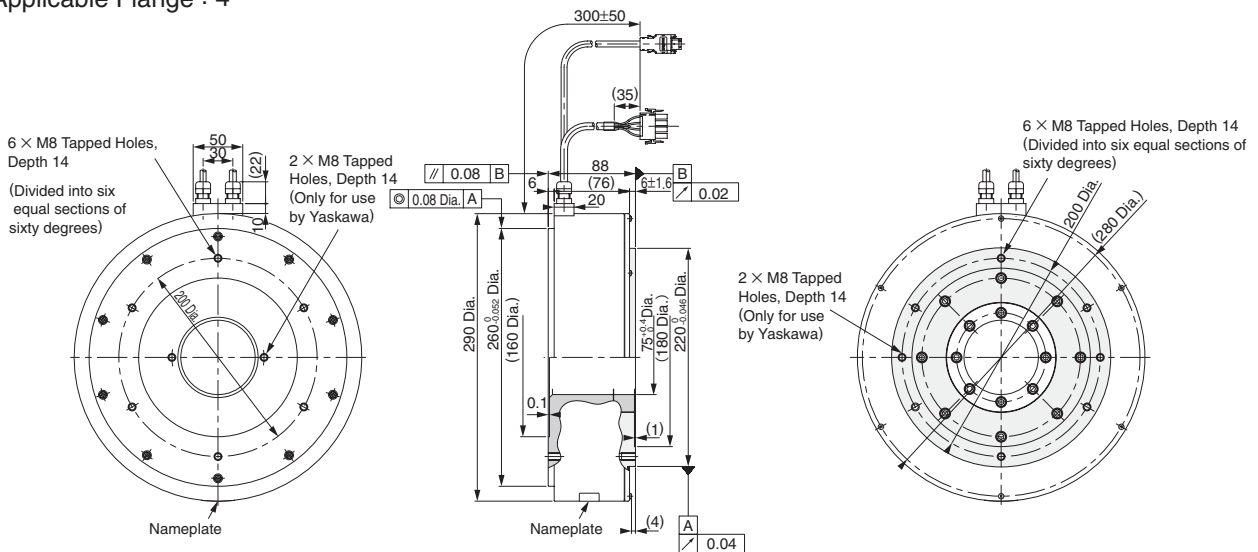

Model SGMCS-	L	LL	Approx. Mass kg
16E□B41	88	76	26.0
35E□B41	112	100	34.0

Selecting Cables

● Cables Connections

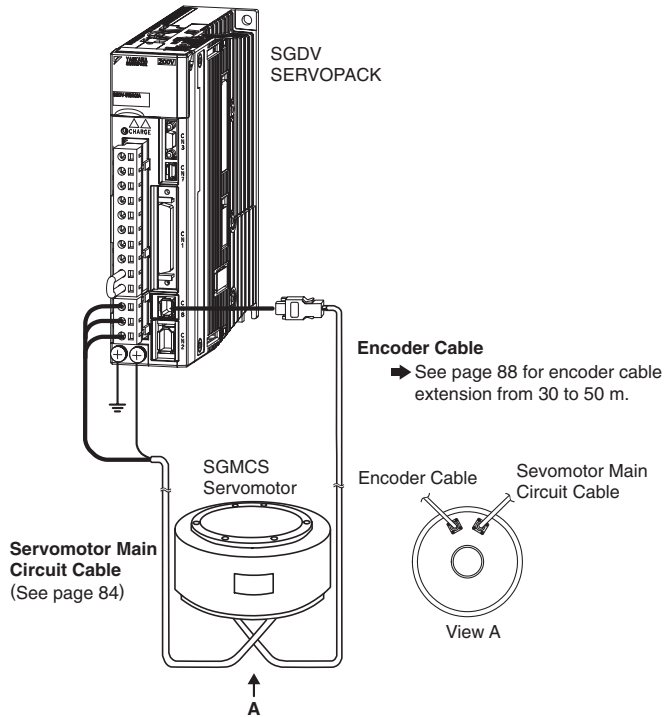

● Servomotor Main Circuit Cables

Contact Yaskawa Controls Co., Ltd.

Name	Length (L)	Order No.		Specifications	Details
		Standard Type	Flexible Type*1		
Cable with Loose Wire at SERVOPACK End	3 m	JZSP-CMM60-03-E	JZSP-CSM60-03-E	Applicable Flange*3 : 1 SERVOPACK End 50 mm Encoder (Servomotor) End M4 Crimped Terminals	(1)
	5 m	JZSP-CMM60-05-E	JZSP-CSM60-05-E		
	10 m	JZSP-CMM60-10-E	JZSP-CSM60-10-E		
	15 m	JZSP-CMM60-15-E	JZSP-CSM60-15-E		
	20 m	JZSP-CMM60-20-E	JZSP-CSM60-20-E		
	3 m	JZSP-CMM00-03-E	JZSP-CMM01-03-E	Applicable Flange*3 : 4 SERVOPACK End 8.5±0.5 (Exposed core wire) 50 Encoder (Servomotor) End Sheath to Bind Core Wires (6.5) Heat-shrinkable Tube M4 Crimped Terminals Cable: UL2517 (AWG20×4C) Cap 350780-1(4-pole) Socket 350536-6(Chained)	
	5 m	JZSP-CMM00-05-E	JZSP-CMM01-05-E		
	10 m	JZSP-CMM00-10-E	JZSP-CMM01-10-E		
	15 m	JZSP-CMM00-15-E	JZSP-CMM01-15-E		
	20 m	JZSP-CMM00-20-E	JZSP-CMM01-20-E		
Servomotor-end Connector		JN1DS04FK1*2		Soldered 	(2)
Cables	5 m	JZSP-CSM90-05-E	JZSP-CSM80-05-E		(3)
	10 m	JZSP-CSM90-10-E	JZSP-CSM80-10-E		
	15 m	JZSP-CSM90-15-E	JZSP-CSM80-15-E		
	20 m	JZSP-CSM90-20-E	JZSP-CSM80-20-E		

*1: Use flexible cables for movable sections such as robot arms.
 *2: Contact Japan Aviation Electronics Industry, Ltd. for details.
 *3: For applicable flanges, see model designations on page 75.
 Note: SGMCS servomotors with holding brakes are not available.

Selecting Cables

(1) Wiring Specifications for Cables

• Applicable Flange : 1

SERVOPACK End		Servomotor End	
Wire Color	Signal	Signal	Pin No.
Red	Phase U	Phase U	1
White	Phase V	Phase V	2
Blue	Phase W	Phase W	3
Green/(yellow)	FG	FG	4

• Applicable Flange : 4

SERVOPACK End		Servomotor End	
Wire Color	Signal	Signal	Pin No.
Red	Phase U	Phase U	1
White	Phase V	Phase V	2
Blue	Phase W	Phase W	3
Green/(yellow)	FG	FG	4

(2) Servomotor-end Connector Specifications

Items	Specifications
Manufacturer	Japan Aviation Electronics Industry, Ltd.
Order No.	JNDS04FK1 (Soldered)
Outer Diameter of Applicable Cable	5.7 dia. to 7.3 dia. mm
External Dimensions mm	

(3) Cable Specifications



Items	Standard Type	Flexible Type
Order No.*	JZSP-CSM90-□□-E (20 m max.)	JZSP-CSM80-□□-E (20 m max.)
Specifications	UL2517 (Max. operating temperature: 105°C) AWG20 × 6C For power line: AWG20 (0.52 mm ²) Outer diameter of insulating sheath: 1.53 dia. mm For brake line: AWG20 (0.52 mm ²) Outer diameter of insulating sheath: 1.53 dia. mm	UL2517 (Max. operating temperature: 105°C) AWG22 × 6C For power line: AWG22 (0.33 mm ²) Outer diameter of insulating sheath: 1.37 dia. mm For brake line: AWG22 (0.33 mm ²) Outer diameter of insulating sheath: 1.37 dia. mm
Finished Dimensions	7 ± 0.3 mm	
Internal Configuration and Lead Color		
Yaskawa Standard Specifications (Standard Length)	Cable length : 5 m, 10 m, 15 m, 20 m	

*: Specify the cable length □□ of order no.
 Example JZSP-CSM90-15-E (15 m)

Selecting Cables

Encoder Cables and Connectors (For Standard Wiring)

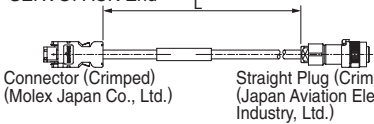
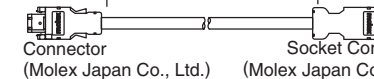
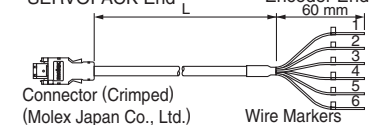
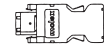
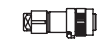
Contact Yaskawa Controls Co., Ltd.

Name	Length (L)	Order No.		Specifications	Details		
		Standard Type	Flexible Type*1				
Cable with Connectors (For Incremental and Absolute Encoder)	3 m	JZSP-CMP60-03-E	JZSP-CSP60-03-E	Applicable Flange*3: 1, 3 SERVOPACK End Encoder (Servomotor) End  Connector (Crimped) (Molex Japan Co., Ltd.) Straight Plug (Crimped) (Japan Aviation Electronics Industry, Ltd.)	(1)		
	5 m	JZSP-CMP60-05-E	JZSP-CSP60-05-E				
	10 m	JZSP-CMP60-10-E	JZSP-CSP60-10-E				
	15 m	JZSP-CMP60-15-E	JZSP-CSP60-15-E				
	20 m	JZSP-CMP60-20-E	JZSP-CSP60-20-E				
	3 m	JZSP-CMP00-03-E	JZSP-CMP10-03-E			Applicable Flange*3 : 4 SERVOPACK End Encoder End  Connector (Molex Japan Co., Ltd.) Socket Connector (Molex Japan Co., Ltd.)	(2)
	5 m	JZSP-CMP00-05-E	JZSP-CMP10-05-E				
	10 m	JZSP-CMP00-10-E	JZSP-CMP10-10-E				
	15 m	JZSP-CMP00-15-E	JZSP-CMP10-15-E				
	20 m	JZSP-CMP00-20-E	JZSP-CMP10-20-E				
Cable with Loose Wire at Encoder End (For Incremental and Absolute Encoder)	3 m	JZSP-CMP03-03-E	JZSP-CMP13-03-E	SERVOPACK End Encoder End 60 mm  Connector (Crimped) (Molex Japan Co., Ltd.) Wire Markers	(3)		
	5 m	JZSP-CMP03-05-E	JZSP-CMP13-05-E				
	10 m	JZSP-CMP03-10-E	JZSP-CMP13-10-E				
	15 m	JZSP-CMP03-15-E	JZSP-CMP13-15-E				
	20 m	JZSP-CMP03-20-E	JZSP-CMP13-20-E				
SERVOPACK-end Connector Kit		JZSP-CMP9-1-E		Soldered 	(4)		
Encoder-end Connector (Straight Plug)		JN1DS10SL1*2		Crimping Type (A crimp tool is required.) 			
Encoder-end Connector (Socket Contact)		JN1-22-22S-PKG100*2					
Cables	5 m	JZSP-CMP09-05-E	JZSP-CSP39-05-E		(5)		
	10 m	JZSP-CMP09-10-E	JZSP-CSP39-10-E				
	15 m	JZSP-CMP09-15-E	JZSP-CSP39-15-E				
	20 m	JZSP-CMP09-20-E	JZSP-CSP39-20-E				

*1: Use flexible cables for movable sections such as robot arms.
 *2: Contact Japan Aviation Electronics Industry, Ltd. for details.
 *3: For applicable flanges, see model designations on page 75.

(1) Wiring Specifications for Cable with Connectors

- Applicable Flange: 1, 3
(Standard type)

SERVOPACK End		Encoder (Servomotor) End	
Pin No.	Signal	Pin No.	Wire Color
1	PG5V	4	Red
2	PG0V	9	Black
5	PS	1	Light blue
6	/PS	2	Light blue/white
Shell	FG	7	FG Shield wire

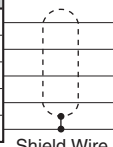

- (Flexible type)

SERVOPACK End		Encoder End	
Pin No.	Signal	Pin No.	Wire Color
1	PG5V	4	Orange
2	PG0V	9	Green
5	PS	1	Black/light blue
6	/PS	2	Red/light blue
Shell	FG	7	Shield

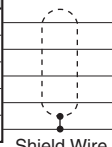

Note: Be sure to connect the shield wire of encoder cable to the connector case (shell).

(2) Wiring Specifications for Cable with Connectors

- Applicable Flange: 4
(Standard type)

SERVOPACK End		Encoder (Servomotor) End	
Pin No.	Signal	Pin No.	Wire Color
1	PG5V	1	Red
2	PG0V	2	Black
5	PS	5	Light blue
6	/PS	6	Light blue/white
Shell	FG	Shell	FG Shield wire

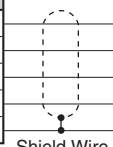

- (Flexible type)

SERVOPACK End		Encoder End	
Pin No.	Signal	Pin No.	Wire Color
1	PG5V	1	Orange
2	PG0V	2	Green
5	PS	5	Red/light blue
6	/PS	6	Black/light blue
Shell	FG	7	Shield

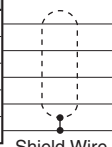

Note: Be sure to connect the shield wire of encoder cable to the connector case (shell).

Selecting Cables

(3) Wiring Specifications for Cable with Loose Wire at Encoder End

(Standard type)

SERVOPACK End		Encoder (Servomotor) End	
Pin No.	Signal	Wire Color	Marker
6	/PS	Light blue/white	6
5	PS	Light blue	5
4	BAT(-)	White/orange	4
3	BAT(+)	Orange	3
2	PG0V	Black	2
1	PG5V	Red	1
Shell	FG		

(Flexible type)

SERVOPACK End		Encoder (Servomotor) End	
Pin No.	Signal	Wire Color	Marker
1	PG5V	Orange	1
2	PG0V	Green	2
3	BAT(+)	BAT(+)	3
4	BAT(-)	BAT(-)	4
5	PS	Red/light blue	5
6	/PS	Black/light blue	6
Shell	FG		

- Notes: 1 The signals BAT (+) and BAT (-) are used when using an absolute encoder.
 2 Be sure to connect the shield wire of encoder cable to the connector case (shell).

(4) SERVOPACK-end Connector Specifications

Items	SERVOPACK End	Encoder End
Order No.	JZSP-CMP9-1-E	Order from Yaskawa Controls Co., Ltd. Tools are not included.
Manufacturer	Molex Japan Co., Ltd.	Japan Aviation Electronics Industry, Ltd.
Connector	55100-0670 (soldered) Note: 55100-0670 (soldered) when using a connector kit	Straight plug: JN1DS10SL1 (crimped) Socket contact type: JN1-22-22S-PKG100 Outer diameter of applicable cable : 5.7 dia. to 7.3 dia. mm Applicable wire size: AWG21 to 25 Outer diameter of insulating sheath: 0.8 dia. to 1.5 dia. mm Crimp tool (hand tool) model: CT150-2-JN
External Dimensions (Units: mm)		

(5) Cable Specifications

Items	Standard Type	Flexible Type
Order No.*	JZSP-CMP09-□□-E	JZSP-CSP39-□□-E
Cable Length	20 m max.	
Specifications	UL20276 (Max. operating temperature: 80°C) AWG22×2C+AWG24×2P AWG22 (0.33 mm ²) Outer diameter of insulating sheath: 1.15 dia. mm AWG24 (0.20 mm ²) Outer diameter of insulating sheath: 1.09 dia. mm	UL20276 (Max. operating temperature: 80°C) AWG22×2C+AWG24×2P AWG22 (0.33 mm ²) Outer diameter of insulating sheath: 1.35 dia. mm AWG24 (0.20 mm ²) Outer diameter of insulating sheath: 1.21 dia. mm
Finished Dimensions	6.5 dia. mm	6.8 dia. mm
Internal Configuration and Lead Colors		
Yaskawa Standard Specifications (Standard Length)	Cable length: 5 m, 10 m, 15 m, 20 m	

* Specify the cable length in □□ of order no.
 Example: JZSP-CMP09-05-E (5 m)

Selecting Cables

● Encoder Cables (For Extending from 30 to 50 m)

To extend the wiring distance up to 50 m, the following cables and connectors are available from Yaskawa Controls Co., Ltd.

• Cable Specifications

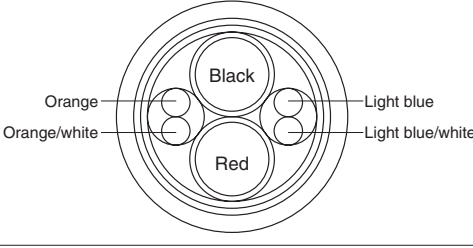
Items	Standard
Order No.*	JZSP-CMP19-□□-E
Cable Length	50 m max.
Specifications	UL20276 (Max. operating temperature: 80°C) AWG16×2C+AWG26×2P AWG16 (1.31 mm ²) Outer diameter of insulating sheath: 2.0 dia.mm AWG26 (0.13 mm ²) Outer diameter of insulating sheath: 0.91 dia. mm
Finished Dimensions	6.8 dia. mm
Internal Configuration and Lead Colors	
Yaskawa Standard Specifications (Standard Length)	Cable length: 30 m, 40 m, 50 m

* Specify the cable length in □□ of order no.
Example: JZSP-CMP19-30-E (30 m)

• SERVOPACK-end Connector Specifications

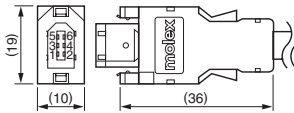
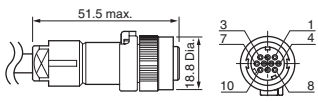
Items	SERVOPACK End	Servomotor End
Order No.	JZSP-CMP9-1-E	Order form Yaskawa Controls Co., Ltd. Tools are not included.
Manufacturer	Molex Japan Co., Ltd.	Japan Aviation Electronics Industry, Ltd.
Connector	55100-0670 (soldered) Note: 55100-0670 (soldered) when using a connector kit	Straight plug: JN1DS10SL1 (crimped) Socket contact : JN1-22-22S-PKG100 Outer diameter of applicable cable : 5.7 dia. to 7.3 dia. mm Applicable wire size: AWG21 to 25 Outer diameter of insulating sheath: 0.8 dia. to 1.5 dia. mm Crimp tool (hand tool) model: CT150-2-JN
External Dimensions (Units: mm)		

Linear Servomotors

SGLGW

(Coreless Type)

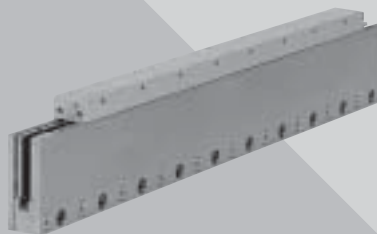

Model Designations

● Coil Assembly

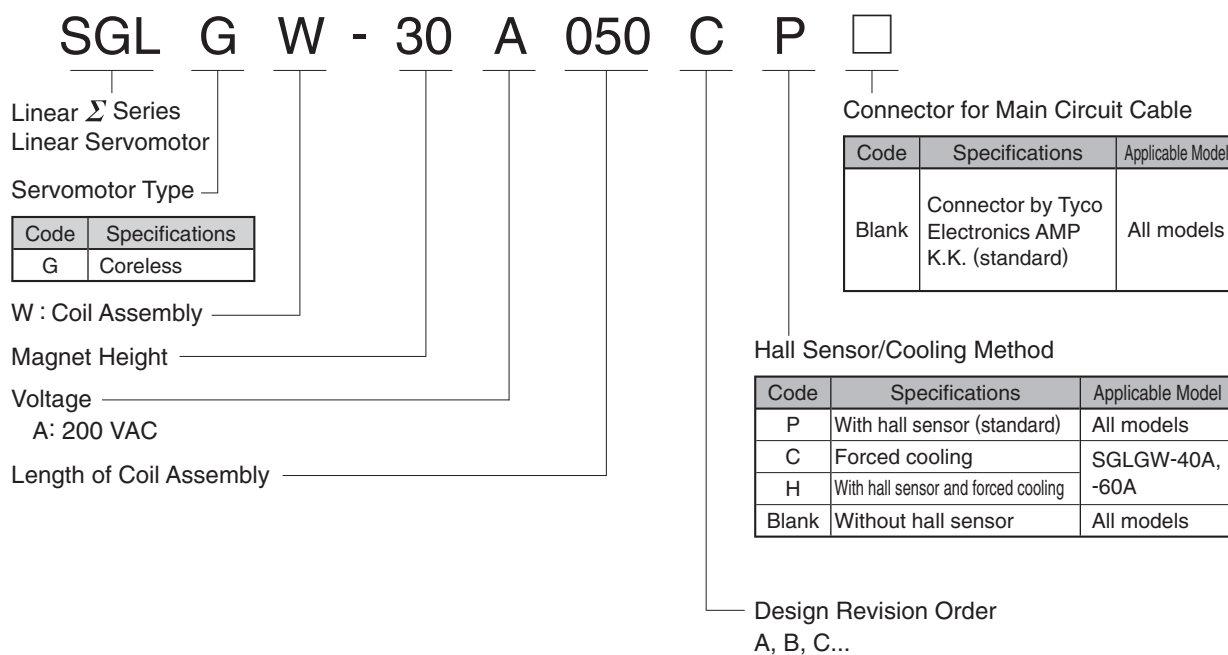

Features

- Direct-feed mechanism for high-speed and high-precision positioning.
- Lack of magnetic attraction force helps extend the life of linear motion guides and minimizes noise.
- Zero cogging for minimal force ripple.

Application Examples

- Feeders and loaders
- Semiconductor equipment
- LCD manufacturing equipment

● Magnetic Way

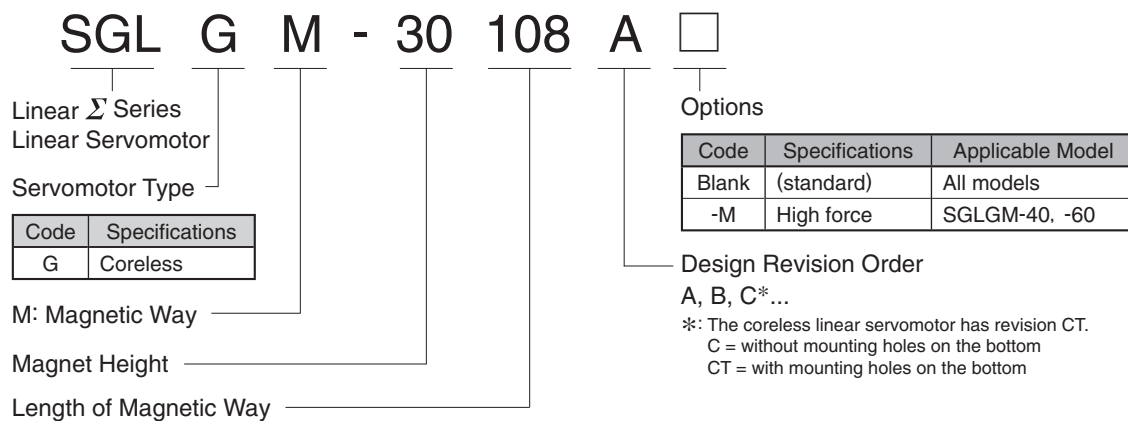

Ratings and Specifications

Time Rating: Continuous
 Insulation Resistance: 500 VDC, 10 MΩ min.
 Ambient Temperature: 0 to 40°C
 Excitation: Permanent magnet

Withstand Voltage: 1500 VAC for one minute
 Enclosure: Self-cooled, air-cooling
 Ambient Humidity: 20% to 80% (no condensation)
 Allowable Winding Temperature: 130°C
 (Thermal class B)

● With Standard-force Magnetic Ways

Linear Servomotor Model SGLGW- <input type="text"/>		30A050C	30A080C	40A140C	40A253C	40A365C	60A140C	60A253C	60A365C
Rated Speed*	m/s	1.5	1.5	2	2	2	2.3	2.3	2.3
Peak Speed*	m/s	5	5	5	5	5	4.8	4.8	4.8
Rated Force*	N	12.5	25	47	93	140	70	140	210
Rated Current*	Arms	0.51	0.79	0.8	1.6	2.4	1.2	2.2	3.3
Peak Force*	N	40	80	140	280	420	220	440	660
Peak Current*	Arms	1.62	2.53	2.4	4.9	7.3	3.5	7.0	10.5
Coil Assembly Mass	kg	0.10	0.15	0.34	0.60	0.87	0.42	0.76	1.10
Force Constant	N/Arms	26.4	33.9	61.5	61.5	61.5	66.6	66.6	66.6
BEMF Constant	V/(m/s)	8.8	11.3	20.5	20.5	20.5	22.2	22.2	22.2
Motor Constant	N/√W	3.7	5.6	7.8	11.0	13.5	11.1	15.7	19.2
Electrical Time Constant	ms	0.2	0.4	0.4	0.4	0.4	0.5	0.5	0.5
Mechanical Time Constant	ms	7.30	4.78	5.59	4.96	4.77	3.41	3.08	2.98
Thermal Resistance (With heat sink)	K/W	5.19	3.11	1.67	0.87	0.58	1.56	0.77	0.51
Thermal Resistance (Without heat sink)	K/W	8.13	6.32	3.02	1.80	1.23	2.59	1.48	1.15
Magnetic Attraction	N	0	0	0	0	0	0	0	0
Applicable SERVOPACK	SGDV	R70A	R90A	R90A	1R6A	2R8A	1R6A	2R8A	5R5A

Notes: 1 The items marked with an * and "Force and Speed Characteristics" (the table below) are the values at a motor winding temperature of 100°C during operation in combination with a SERVOPACK. The others are at 20°C.

2 The above specifications show the values under the cooling condition when a heat sink (aluminium board) listed in the following table is mounted on the coil assembly.

[Heat Sink Size] 200 mm × 300 mm × 12 mm : SGLGW-30A050C, -30A080C, -40A140C, -60A140C
 300 mm × 400 mm × 12 mm : SGLGW-40A253C, -60A253C
 400 mm × 500 mm × 12 mm : SGLGW-40A365C, -60A365C

● Force and Speed Characteristics A : Continuous Duty Zone B : Intermittent Duty Zone

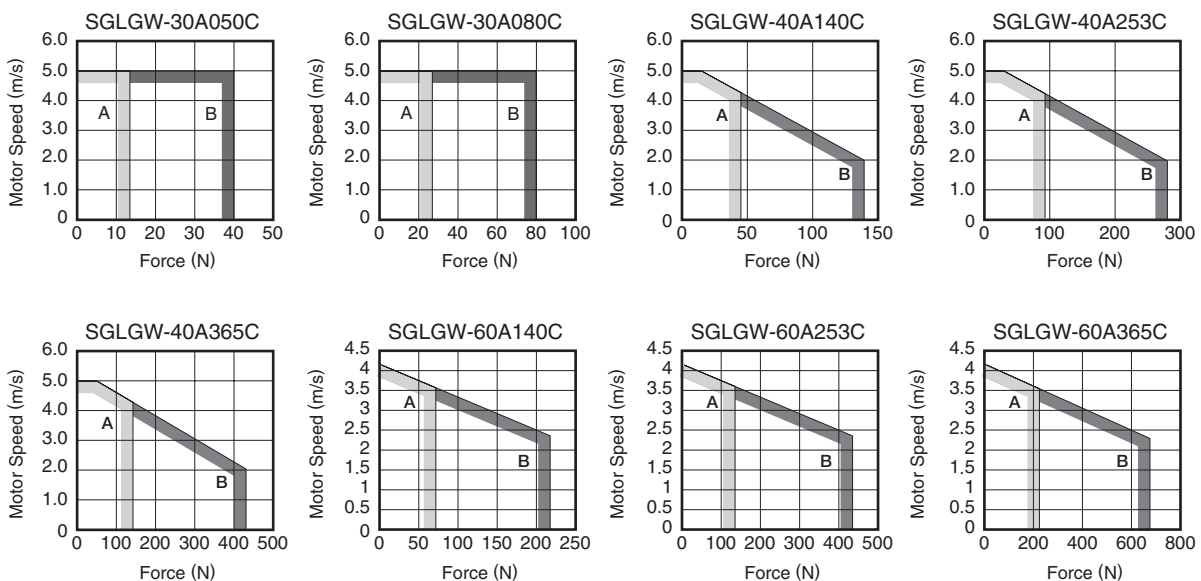

Ratings and Specifications

● With High-force Magnetic Ways

Linear Servomotor Model SGLGW- 		40A140C	40A253C	40A365C	60A140C	60A253C
Rated Speed*	m/s	1.0	1.0	1.0	1.0	1.0
Peak Speed*	m/s	4.2	4.2	4.2	4.2	4.2
Rated Force*	N	57	114	171	85	170
Rated Current*	Arms	0.8	1.6	2.4	1.2	2.2
Peak Force*	N	230	460	690	360	720
Peak Current*	Arms	3.2	6.5	9.7	5.0	10.0
Coil Assembly Mass	kg	0.34	0.60	0.87	0.42	0.76
Force Constant	N/Arms	76.0	76.0	76.0	77.4	77.4
BEMF Constant	V/(m/s)	25.3	25.3	25.3	25.8	25.8
Motor Constant	N/√W	9.6	13.6	16.7	12.9	18.2
Electrical Time Constant	ms	0.4	0.4	0.4	0.5	0.5
Mechanical Time Constant	ms	3.69	3.24	3.12	2.52	2.29
Thermal Resistance (With heat sink)	K/W	1.67	0.87	0.58	1.56	0.77
Thermal Resistance (Without heat sink)	K/W	3.02	1.80	1.23	2.59	1.48
Magnetic Attraction	N	0	0	0	0	0
Applicable SERVOPACK	SGDV	1R6A	2R8A	3R8A	1R6A	3R8A

Notes: 1 The items marked with an * and "Force and Speed Characteristics" (the table below) are the values at a motor winding temperature of 100°C during operation in combination with a SERVOPACK. The others are at 20°C.
 2 The above specifications show the values under the cooling condition when a heat sink (aluminum board) listed in the following table is mounted on the coil assembly.

Heat Sink Size	200 mm × 300 mm × 12 mm	300 mm × 400 mm × 12 mm	400 mm × 500 mm × 12 mm
SGLGW-40A140C, -60A140C			
SGLGW-40A253C, -60A253C			
SGLGW-40A365C			

● Force and Speed Characteristics A : Continuous Duty Zone B : Intermittent Duty Zone

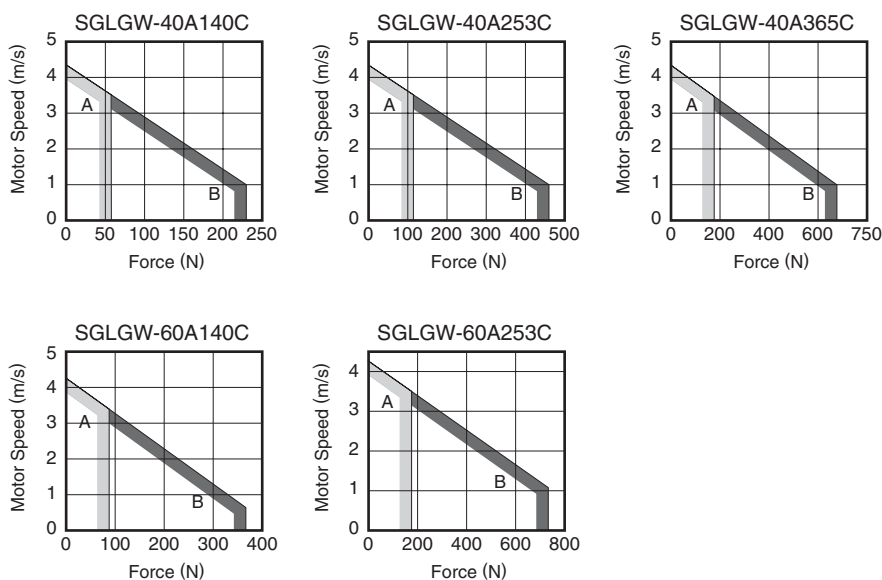

● Mechanical Specifications

(1) Impact Resistance

- Impact acceleration: 196 m/s²
- Impact occurrences: twice

(2) Vibration Resistance

The linear servomotors will withstand the following vibration acceleration in three directions: Vertical, side to side, and front to back.

- Vibration acceleration: 49 m/s²

External Dimensions Units: mm

(1) SGLGW-30A

- Coil Assembly: SGLGW-30A□□□B□ (With a connector by Tyco Electronics AMP K.K.)

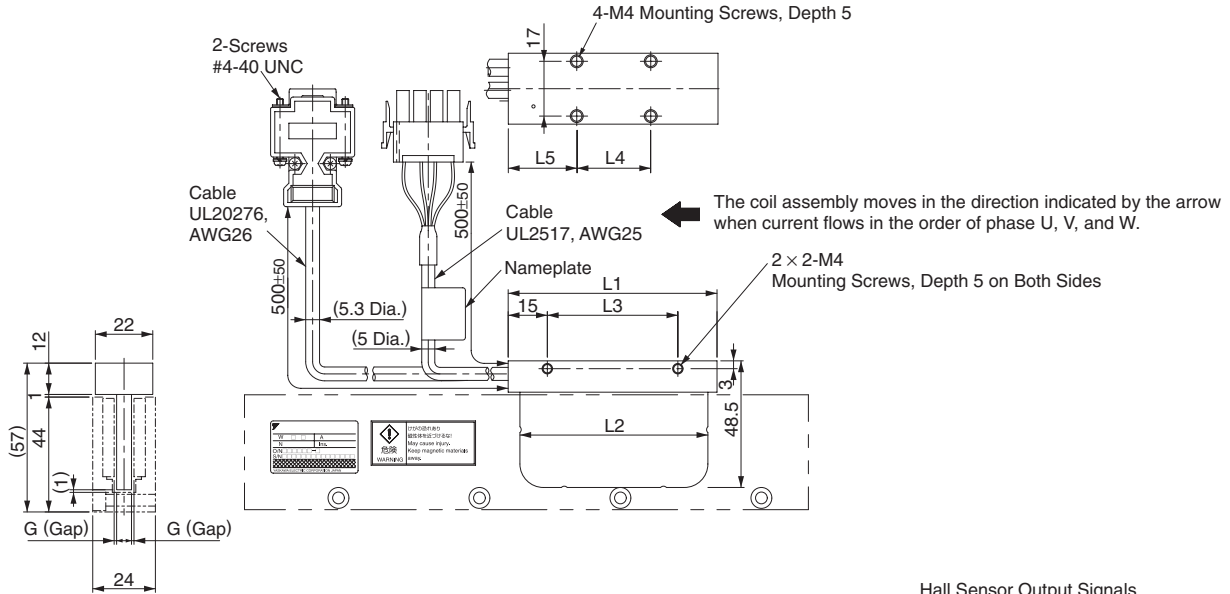

Hall Sensor Connector Specifications

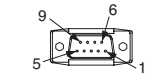

Pin Connector:
17JE-23090-02 (D8C)
by DDK Ltd.

The Mating Connector

Socket Connector
: 17JE-13090-02 (D8C)
Stud : 17L-002C or
17L-002C1

Pin No.	Signal
1	+5V (Power supply)
2	Phase U
3	Phase V
4	Phase W
5	0V (Power supply)
6	Not used
7	Not used
8	Not used
9	Not used

Linear Servomotor Connector Specifications

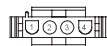

Plug : 350779-1
Pin : 350924-1 or
770672-1
by Tyco Electronics AMP K.K.

The Mating Connector

Cap : 350780-1
Socket : 350925-1 or
770673-1

Pin No.	Signal	Wire Color
1	Phase U	Red
2	Phase V	White
3	Phase W	Blue
4	FG	Green

Hall Sensor Output Signals

When the coil assembly moves in the direction indicated by the arrow in the figure, the relationship between the hall sensor output signals Su, Sv, Sw and the inverse power of each motor phase Vu, Vv, Vw becomes as shown in the figure below.

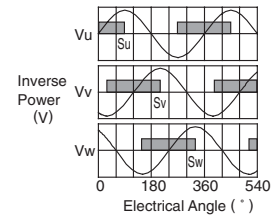

Coil Assembly Model SGLGW-□□□□	L1	L2	L3	L4	L5	G (Gap)	Approx. Mass* kg
30A050B□	50	48	30	20	20	0.85	0.14
30A080B□	80	72	50	30	25	0.95	0.19

*: The values indicate the mass of coil assembly with a hall sensor unit.

- Magnetic Way: SGLGM-30□□□A

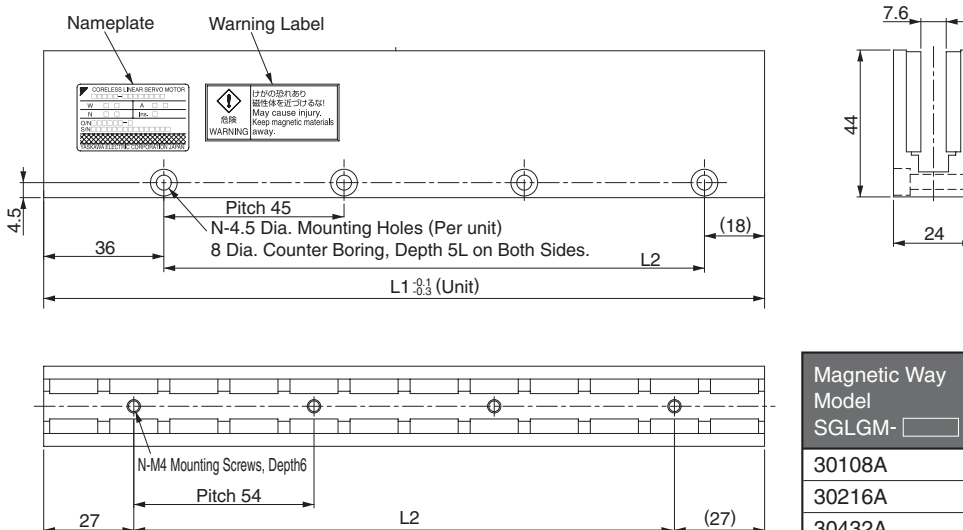

Magnetic Way Model SGLGM-□□□□	L1	L2	N	Approx. Mass kg
30108A	108	54	2	0.6
30216A	216	162	4	1.1
30432A	432	378	8	2.3

External Dimensions Units: mm

(2) SGLGW-40A

- Coil Assembly: SGLGW-40A□□□□C□ (With a connector by Tyco Electronics AMP K.K.)

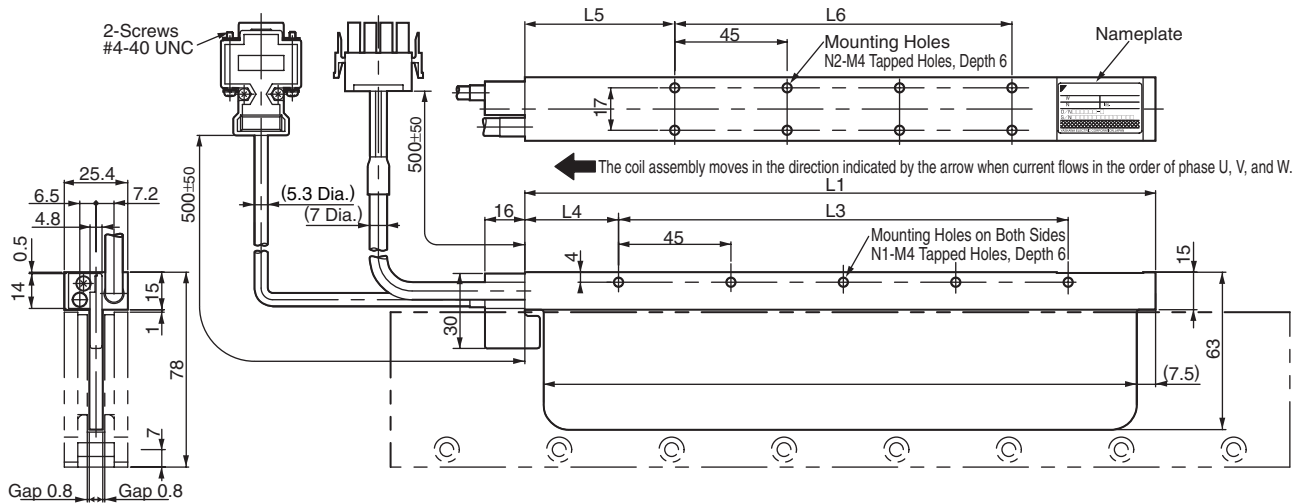

Hall Sensor Connector Specifications

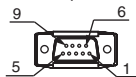

Pin Connector :
 17JE-23090-02 (D8C)
 by DDK Ltd.

The Mating Connector

Socket Connector :
 17JE-13090-02 (D8C)
 Stud : 17L-002C or
 17L-002C1

Pin No.	Signal
1	+5V (Power supply)
2	Phase U
3	Phase V
4	Phase W
5	0V (Power supply)
6	Not used
7	Not used
8	Not used
9	Not used

Linear Servomotor Connector Specifications

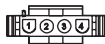

Plug : 350779-1
 Pin : 350561-3 or
 350690-3 (No.1 to 3)
 350654-1
 350669-1 (No.4)
 by Tyco Electronics AMP K.K.

The Mating Connector
 Cap : 350780-1
 Socket : 350570-3 or
 350689-3

Pin No.	Signal	Wire Color
1	Phase U	Red
2	Phase V	White
3	Phase W	Blue
4	FG	Green

Hall Sensor Output Signals

When the coil assembly moves in the direction indicated by the arrow in the figure, the relationship between the hall sensor output signals S_u , S_v , S_w and the inverse power of each motor phase V_u , V_v , V_w becomes as shown in the figure below.

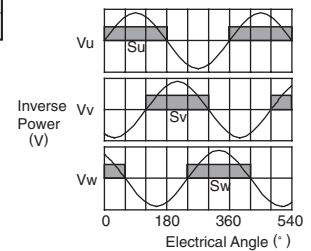

Coil Assembly Model SGLGW-	L1	L2	L3	L4	L5	L6	N1	N2	Approx. Mass* kg
40A140C□	140	125	90	30	52.5	45	3	4	0.40
40A253C□	252.5	237.5	180	37.5	60	135	5	8	0.66
40A365C□	365	350	315	30	52.5	270	8	14	0.93

*: The values indicate the mass of coil assembly with a hall sensor unit.

External Dimensions Units: mm

- Magnetic Way : SGLGM-40□□□C (Without mounting holes on the bottom)
SGLGM-40□□□CT (With mounting holes on the bottom)

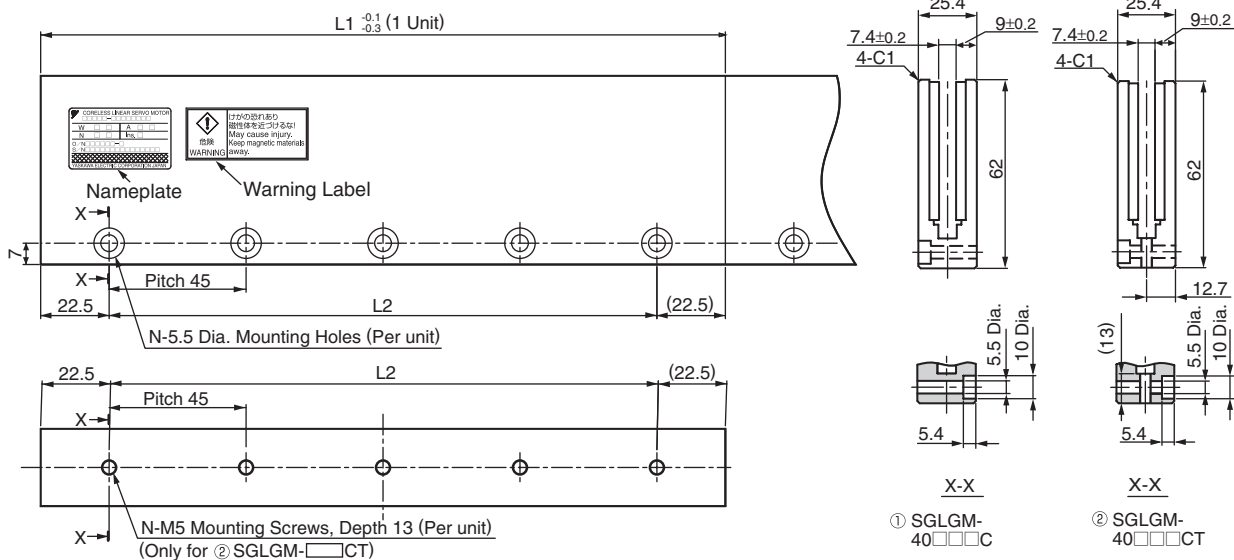

Type	Standard-force Magnetic Way Model SGLGM-	L1	L2	N	Approx. Mass kg
Standard Force	40090C or 40090CT	90	45	2	0.8
	40225C or 40225CT	225	180	5	2.0
	40360C or 40360CT	360	315	8	3.1
	40405C or 40405CT	405	360	9	3.5
	40450C or 40450CT	450	405	10	3.9

- High-force Magnetic Way : SGLGM-40□□□C-M (Without mounting holes on the bottom)
SGLGM-40□□□CT-M (With mounting holes on the bottom)

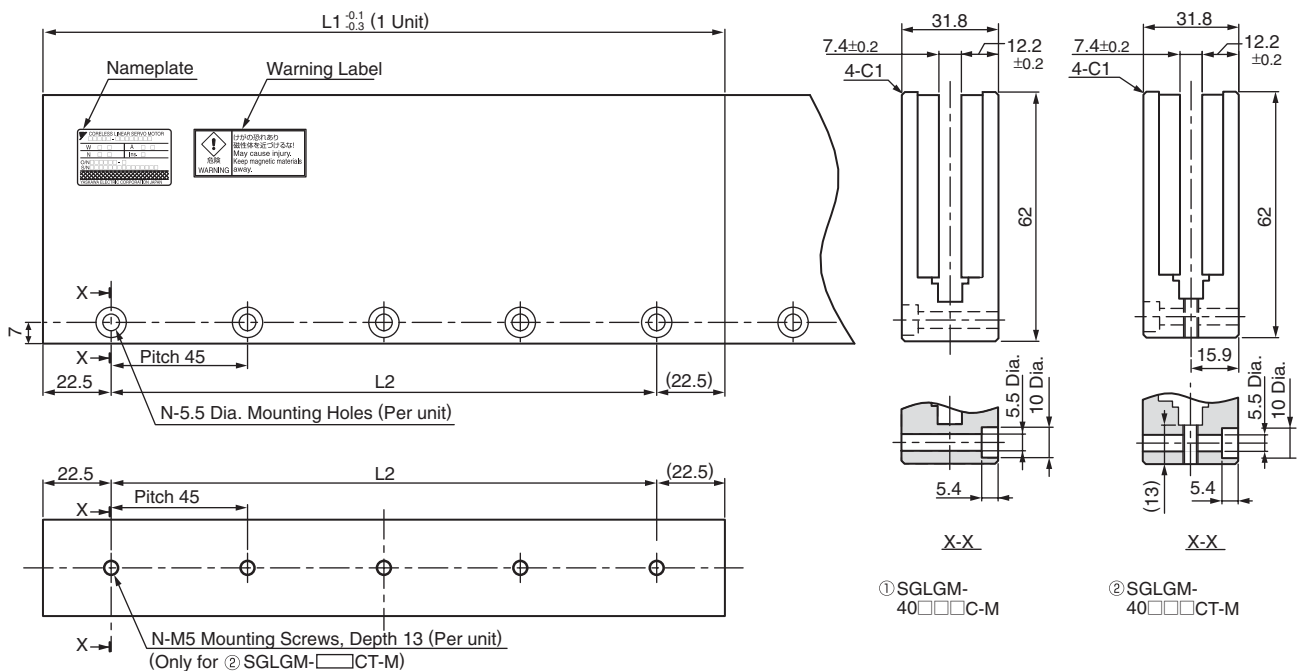

Type	High-force Magnetic Way Model SGLGM-	L1	L2	N	Approx. Mass kg
High Force	40090C-M or 40090CT-M	90	45	2	1.0
	40225C-M or 40225CT-M	225	180	5	2.6
	40360C-M or 40360CT-M	360	315	8	4.1
	40405C-M or 40405CT-M	405	360	9	4.6
	40450C-M or 40450CT-M	450	405	10	5.1

External Dimensions Units: mm

(3) SGLGW-60A

- Coil Assembly: SGLGW-60A□□□□C□
(With a connector by Tyco Electronics AMP K.K.)

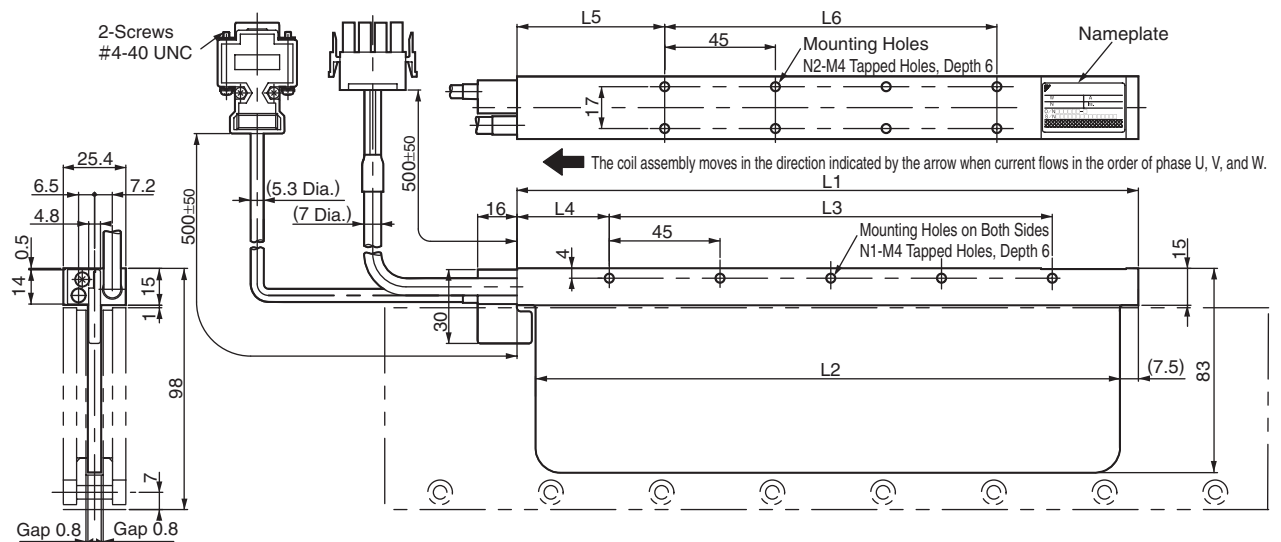

Hall Sensor Connector Specifications

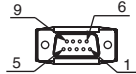

Pin Connector :
17JE-23090-02 (D8C)
by DDK Ltd.

The Mating Connector
Socket Connector :
17JE-13090-02 (D8C)
Stud : 17L-002C or
17L-002C1

Pin No.	Signal
1	+5V (Power supply)
2	Phase U
3	Phase V
4	Phase W
5	0V (Power supply)
6	Not used
7	Not used
8	Not used
9	Not used

Linear Servomotor Connector Specifications



Plug : 350779-1
Pin : 350561-3 or
350690-3 (No.1 to 3)
350654-1
350669-1 (No.4)
by Tyco Electronics AMP K.K.

The Mating Connector
Cap : 350780-1
Socket : 350570-3 or
350689-3

Pin No.	Signal	Wire Color
1	Phase U	Red
2	Phase V	White
3	Phase W	Blue
4	FG	Green

Hall Sensor Output Signals

When the coil assembly moves in the direction indicated by the arrow in the figure, the relationship between the hall sensor output signals S_u , S_v , S_w and the inverse power of each motor phase V_u , V_v , V_w becomes as shown in the figure below.

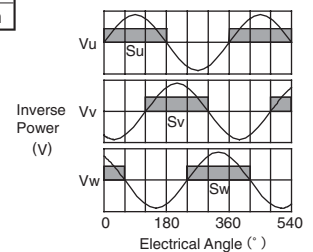

Coil Assembly Model SGLGW-	L1	L2	L3	L4	L5	L6	N1	N2	Approx. Mass* kg
60A140C□	140	125	90	30	52.5	45	3	4	0.48
60A253C□	252.5	237.5	180	37.5	60	135	5	8	0.82
60A365C□	365	350	315	30	52.5	270	8	14	1.16

*: The values indicate the mass of coil assembly with a hall sensor unit.

External Dimensions Units: mm

- Magnetic Way : SGLGM-60□□□C (Without mounting holes on the bottom)
SGLGM-60□□□CT (With mounting holes on the bottom)

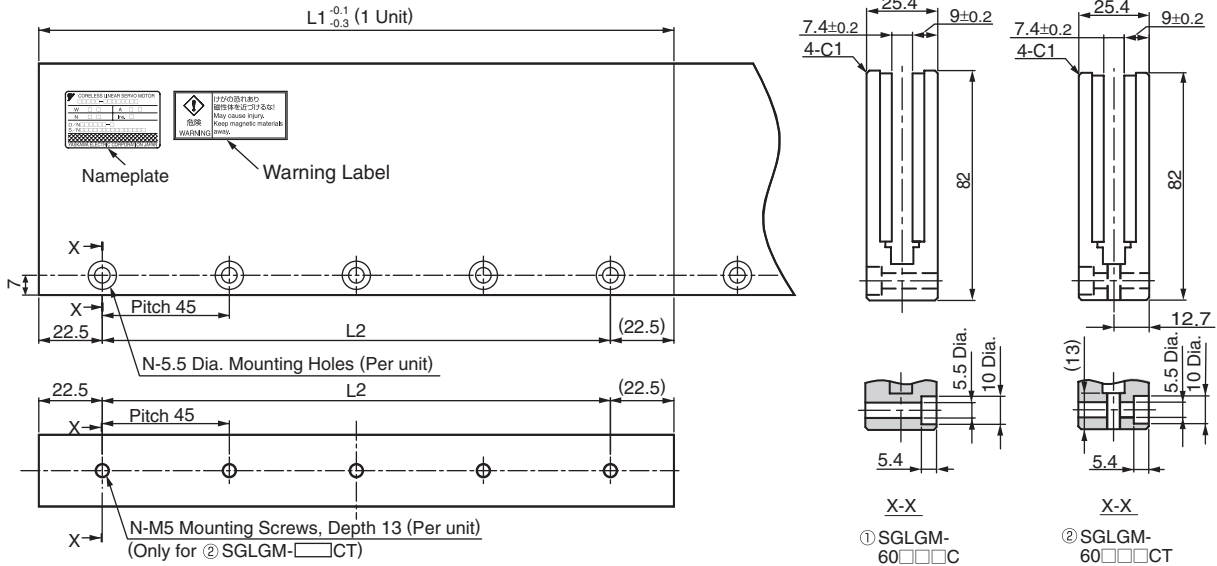

Type	Standard-force Magnetic Way Model SGLGM-	L1	L2	N	Approx. Mass kg
Standard Force	60090C or 60090CT	90	45	2	1.1
	60225C or 60225CT	225	180	5	2.6
	60360C or 60360CT	360	315	8	4.1
	60405C or 60405CT	405	360	9	4.6
	60450C or 60450CT	450	405	10	5.1

- High-force Magnetic Way : SGLGM-60□□□C-M (Without mounting holes on the bottom)
SGLGM-60□□□CT-M (With mounting holes on the bottom)

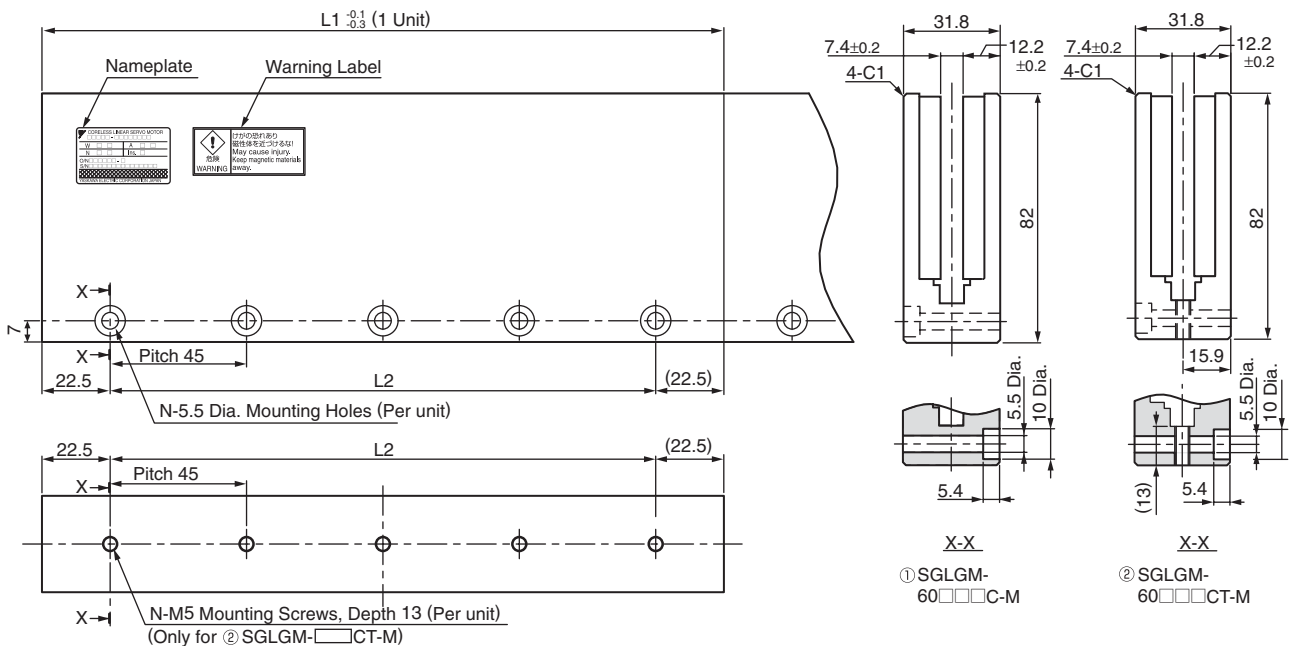

Type	High-force Magnetic Way Model SGLGM-	L1	L2	N	Approx. Mass kg
High Force	60090C-M or 60090CT-M	90	45	2	1.3
	60225C-M or 60225CT-M	225	180	5	3.3
	60360C-M or 60360CT-M	360	315	8	5.2
	60405C-M or 60405CT-M	405	360	9	5.9
	60450C-M or 60450CT-M	450	405	10	6.6

Selecting Cables

● Cables Connections

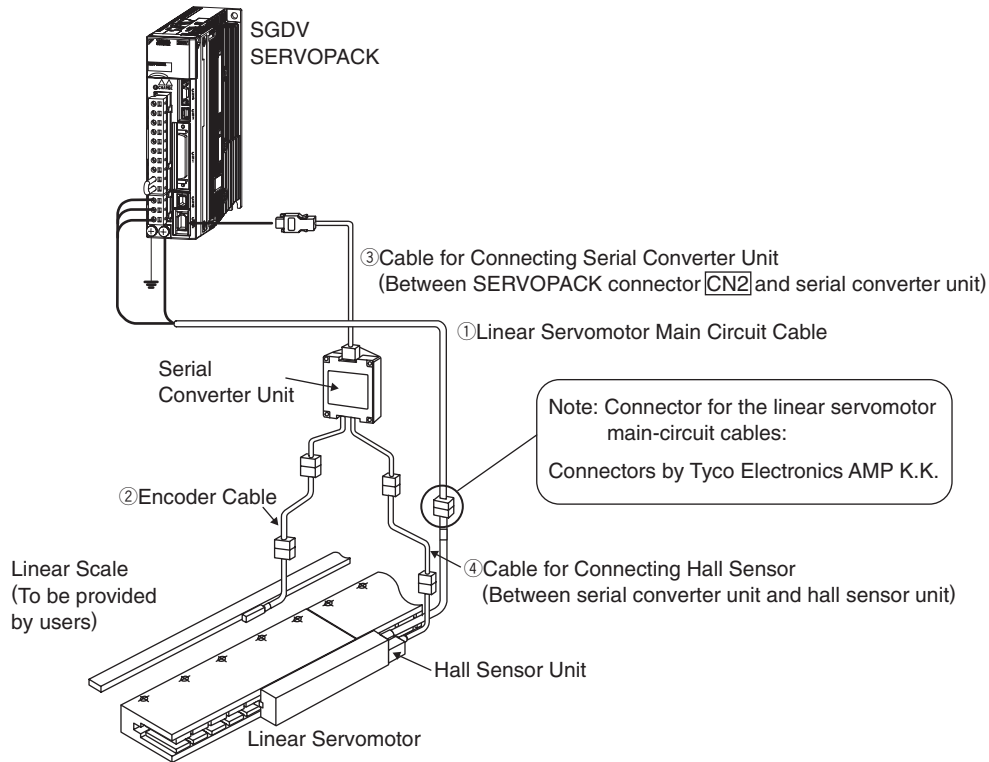

● Cables

Contact Yaskawa Controls Co., Ltd.

Name	Applicable Linear Servomotor Model	Length	Order No.	Specifications	Details
① Linear Servomotor Main Circuit Cables	All models	1 m	JZSP-CLN11-01-E		(1)
		3 m	JZSP-CLN11-03-E		
		5 m	JZSP-CLN11-05-E		
		10 m	JZSP-CLN11-10-E		
		15 m	JZSP-CLN11-15-E		
20 m	JZSP-CLN11-20-E				
② Encoder Cables	All models	1 m	JZSP-CLL00-01-E		(2)
		3 m	JZSP-CLL00-03-E		
		5 m	JZSP-CLL00-05-E		
		10 m	JZSP-CLL00-10-E		
		15 m	JZSP-CLL00-15-E		
③ Cables for Connecting Serial Converter Units	All models	1 m	JZSP-CLP70-01-E		(3)
		3 m	JZSP-CLP70-03-E		
		5 m	JZSP-CLP70-05-E		
		10 m	JZSP-CLP70-10-E		
		15 m	JZSP-CLP70-15-E		
		20 m	JZSP-CLP70-20-E		
④ Cables for Connecting Hall Sensors	All models	1 m	JZSP-CLL10-01-E		(4)
		3 m	JZSP-CLL10-03-E		
		5 m	JZSP-CLL10-05-E		
		10 m	JZSP-CLL10-10-E		
		15 m	JZSP-CLL10-15-E		

Linear Servomotors

Selecting Cables

(1) Linear Servomotor Main Circuit Cables: JZSP-CLN11-□□-E

· Wiring Specifications

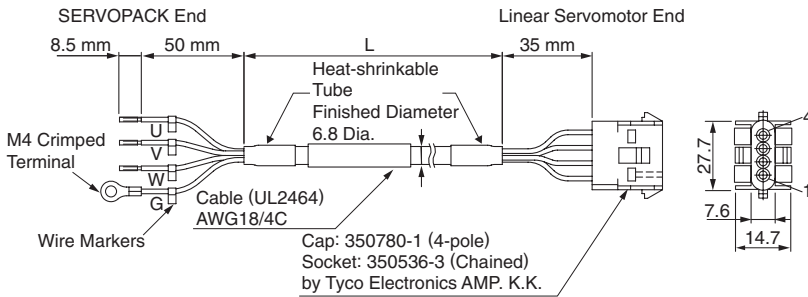

SERVOPACK-end Leads		Linear Servomotor-end Connector	
Wire Color	Signal	Signal	Pin. No.
Red	Phase U	Phase U	1
White	Phase V	Phase V	2
Blue	Phase W	Phase W	3
Green/yellow	FG	FG	4

(2) Encoder Cables: JZSP-CLL00-□□-E

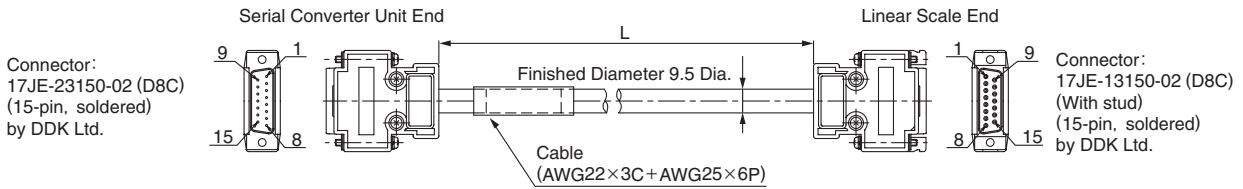

· Wiring Specifications

Serial Converter Unit End		Linear Scale End	
Pin No.	Signal	Pin No.	Signal
1	/Cos (V1-)	1	/Cos (V1-)
2	/Sin (V2-)	2	/Sin (V2-)
3	Ref (V0+)	3	Ref (V0+)
4	+5V	4	+5V
5	5Vs	5	5Vs
6	BID	6	BID
7	Vx	7	Vx
8	Vq	8	Vq
9	Cos (V1+)	9	Cos (V1+)
10	Sin (V2+)	10	Sin (V2+)
11	/Ref (V0+)	11	/Ref (V0-)
12	0V	12	0V
13	0Vs	13	0Vs
14	DIR	14	DIR
15	Inner	15	Inner
Case	Shield	Case	Shield

Selecting Cables

(3) Cables for Connecting Serial Converter Units: JZSP-CLP70-□□-E

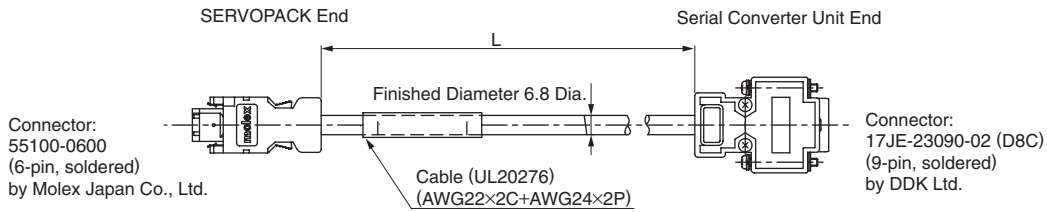

• Wiring Specifications

SERVOPACK End			Serial Converter Unit End		
Pin No.	Signal	Wire Color	Pin No.	Signal	Wire Color
1	PG5V	Red	1	+5V	Red
2	PG0V	Black	5	0V	Black
3	—	—	3	—	—
4	—	—	4	—	—
5	PS	Light blue	2	Phase S output	Light blue
6	/PS	Light blue/white	6	Phase /S output	Light blue/white
Shell	Shield	—	Case	Shield	—
			7	—	—
			8	—	—
			9	—	—

(4) Cables for Connecting Hall Sensors: JZSP-CLL10-□□-E

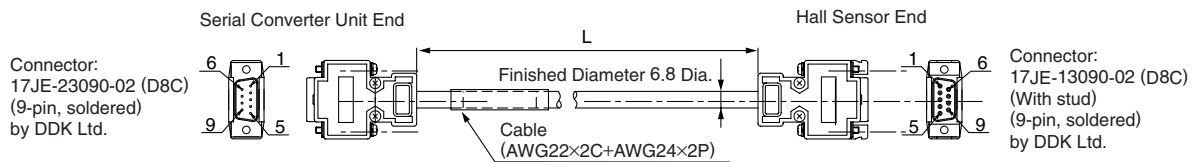

• Wiring Specifications

Serial Converter Unit End		Hall Sensor End	
Pin No.	Signal	Pin No.	Signal
1	+5V	1	+5V
2	Phase U input	2	Phase U input
3	Phase V input	3	Phase V input
4	Phase W input	4	Phase W input
5	0V	5	0V
6	—	6	—
7	—	7	—
8	—	8	—
9	—	9	—
Case	Shield	Case	Shield

Linear Servomotors

SGLFW

(With F-type iron core)

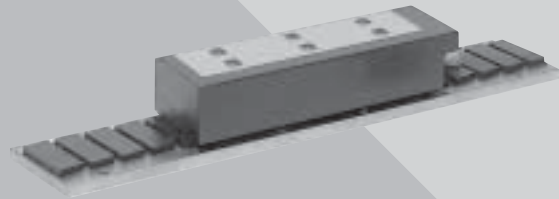

Model Designations

● Coil Assembly

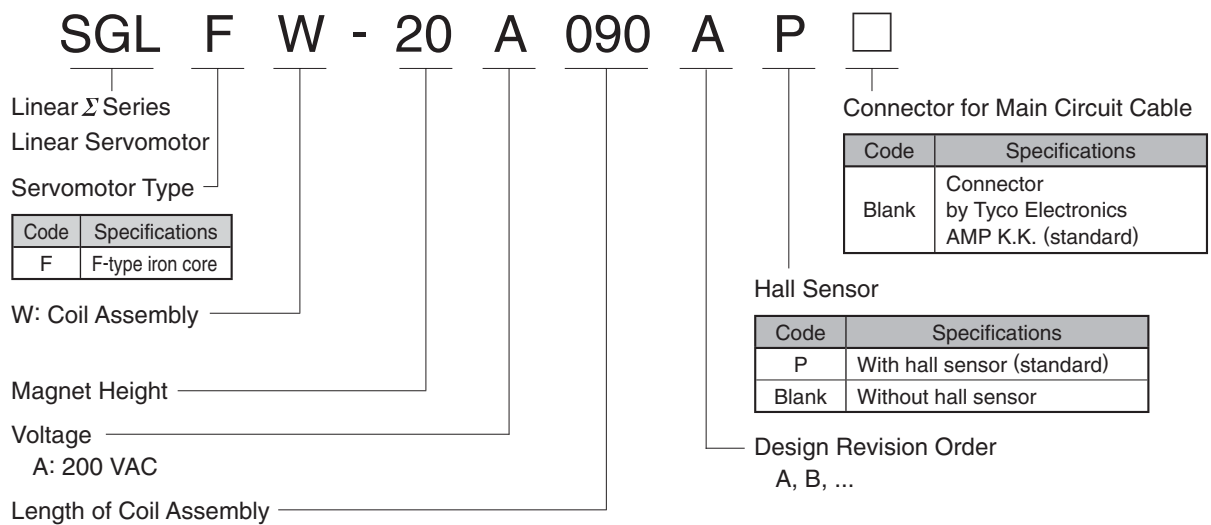

Features

- Direct-feed mechanism for high-speed and high-precision positioning.
- The magnetic attraction force between the moving and stationary members can be used effectively to increase the rigidity of the linear guidance by preloading the linear motion bearings.
- The magnetic preloading on certain types of compliant linear motion bearings can help increase the system's frequency response, improving its deceleration and settling performances.

Application Examples

- Feeders and loaders
- Semiconductor equipment
- LCD manufacturing equipment

● Magnetic Way

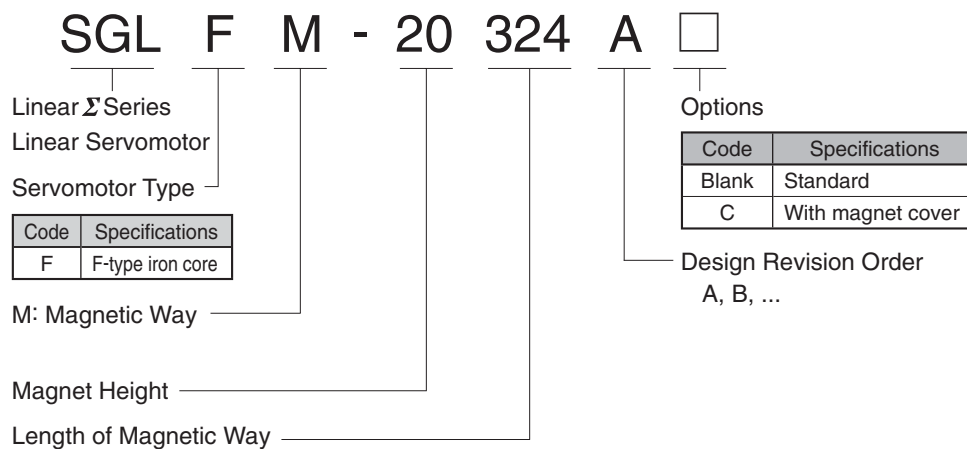

Ratings and Specifications

Time Rating: Continuous
 Insulation Resistance: 500 VDC, 10 MΩ min.
 Ambient Temperature: 0 to 40°C
 Excitation: Permanent magnet

Withstand Voltage: 1500 VAC for one minute
 Enclosure: Self-cooled
 Ambient Humidity: 20% to 80% (no condensation)
 Allowable Winding Temperature: 130°C
 (Thermal class B)

Linear Servomotor Model SGLFW- 		20A090A	20A120A	35A120A	35A230A	50A200B
Rated Speed*	m/s	5.0	3.5	2.5	3.0	1.5
Peak Speed*	m/s	5.0	5.0	5.0	5.0	5.0
Rated Force*	N	25	40	80	160	280
Rated Current*	Arms	0.70	0.80	1.4	2.8	5.0
Peak Force*	N	86	125	220	440	600
Peak Current*	Arms	3.0	2.9	4.4	8.8	12.4
Coil Assembly Mass	kg	0.7	0.9	1.3	2.3	3.5
Force Constant	N/Arms	36.0	54.0	62.4	62.4	60.2
BEMF Constant	V/ (m/s)	12.0	18.0	20.8	20.8	20.1
Motor Constant	N/√w	7.9	9.8	14.4	20.4	34.3
Electrical Time Constant	ms	3.2	3.29	3.63	3.6	15.9
Mechanical Time Constant	ms	11.0	9.31	6.23	5.51	3.0
Thermal Resistance (With Heat Sink)	K/W	4.35	3.19	1.57	0.96	0.56
Thermal Resistance (Without Heat Sink)	K/W	7.69	5.02	4.10	1.94	1.65
Magnetic Attraction	N	314	462	809	1590	1650
Applicable SERVOPACK	SGDV-	1R6	1R6	1R6	3R8	5R5

Notes: 1 The items marked with an* and "Force and Speed Characteristics" (the table below) are the values at a motor winding temperature of 100°C during operation in combination with a SERVOPACK. The others are at 20°C.

2 The above specifications show the values under the cooling condition when a heat sink (aluminum board) listed in the following table is mounted on the coil assembly.

Heat Sink Size	:125 mm×125 mm×13 mm: SGLFW-20A090A, -20A120A
	254 mm×254 mm×25 mm: SGLFW-35A120A, -35A230A
	400 mm×500 mm×40 mm: SGLFW-50A200B

● Force and Speed Characteristics

A : Continuous Duty Zone **B** : Intermittent Duty Zone

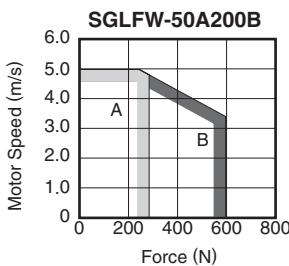
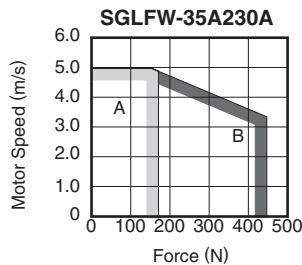
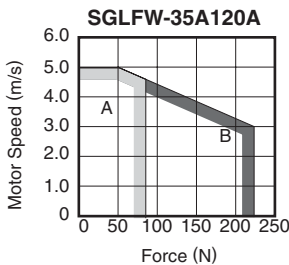
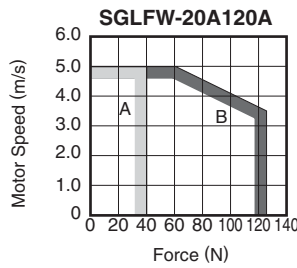
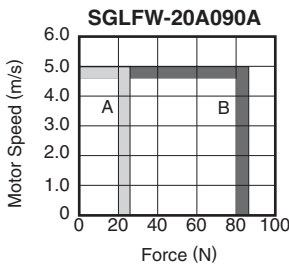

● Mechanical Specifications

(1) Impact Resistance

- Impact acceleration: 196 m/s²
- Impact occurrences: twice

(2) Vibration Resistance

The linear servomotors will withstand the following vibration acceleration in three directions: Vertical, side to side, and front to back.

- Vibration acceleration: 49 m/s²

External Dimensions Units: mm

(1) SGLFW-20A

· Coil Assembly: SGLFW-20A□□□A□

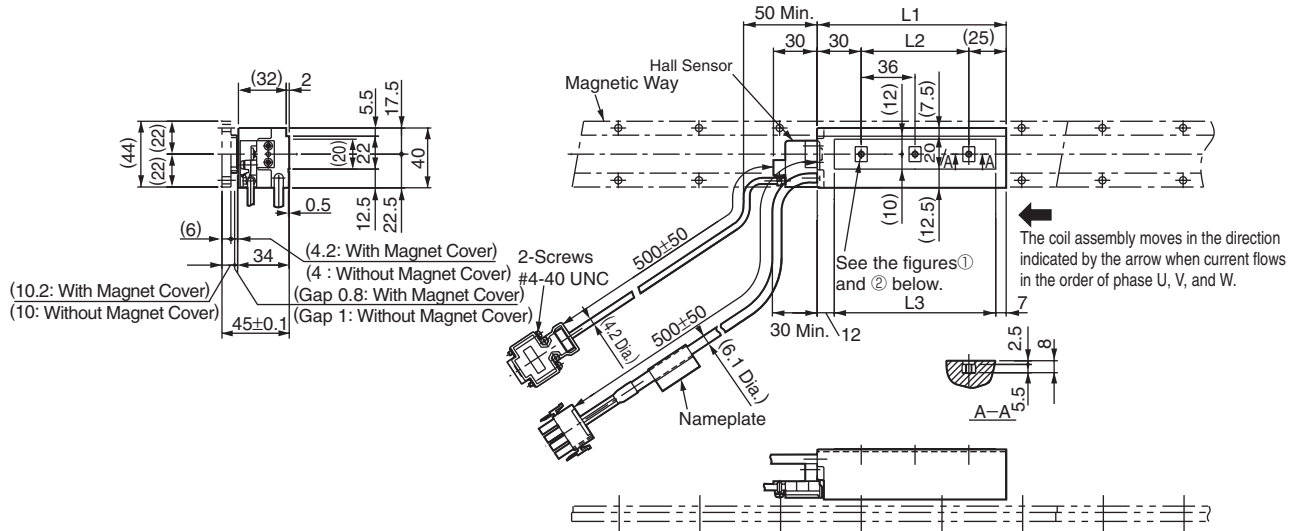

① SGLFW-20A090A□

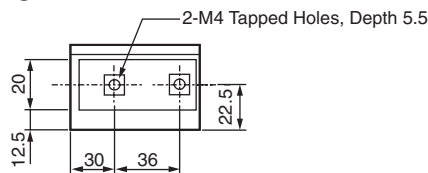

② SGLFW-20A120A□

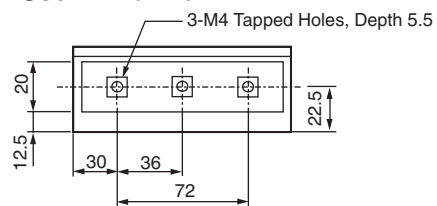

Hall Sensor Connector Specifications

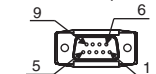

Pin Connector : 17JE-13090-02 (D8C) by DDK Ltd.

The Mating Connector

Socket Connector: 17JE-13090-02 (D8C) Stud: 17L-002C or 17L-002C1

Pin No.	Signal
1	+5V (Power supply)
2	Phase U
3	Phase V
4	Phase W
5	0V (Power supply)
6	Not used
7	Not used
8	Not used
9	Not used

Linear Servomotor Connector Specifications



Plug: 350779-1
 Pin : 350218-3 or 350547-3 (No.1 to 3) 350654-1 350669-1 (No.4) by Tyco Electronics AMP K.K.

The Mating Connector

Cap : 350780-1
 Socket: 350536-3 or 350550-3

Pin No.	Signal	Wire Color
1	Phase U	Red
2	Phase V	White
3	Phase W	Black
4	FG	Green

Hall Sensor Output Signals

When the coil assembly moves in the direction indicated by the arrow in the figure, the relationship between the hall sensor output signals S_u , S_v , S_w and the inverse power of each motor phase V_u , V_v , V_w becomes as shown in the figure below.

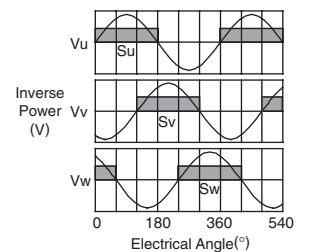

Coil Assembly Model SGLFW-	L1	L2	L3	Approx. Mass kg
20A090A□	91	36	72	0.7
20A120A□	127	72	108	0.9

External Dimensions Units: mm

• Magnetic Way: SGLFM-20□□□A

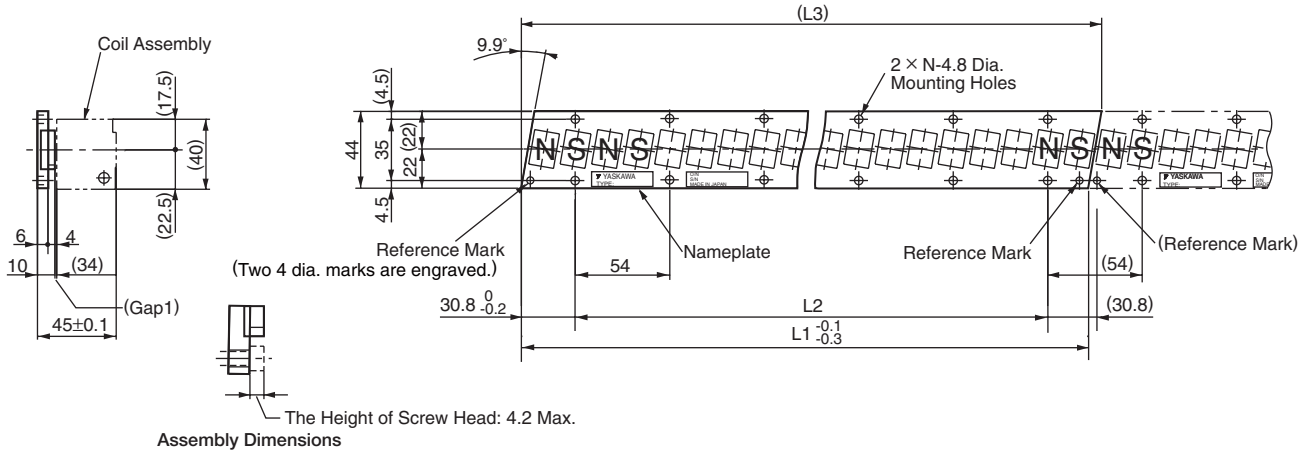

Notes: 1 Multiple SGLFM-20□□□A magnetic ways can be connected. Connect magnetic ways so that the reference marks match one on the other in the same direction as shown in the figure.

2 The magnetic way may affect pacemakers. Keep a minimum distance of 200 mm from the magnetic way.

Magnetic Way Model SGLFM-	L1 ^{-0.1} _{-0.3}	L2	(L3)	N	Approx. Mass kg
20324A	324	270 (54×5)	(331.6)	6	0.9
20540A	540	486 (54×9)	(547.6)	10	1.4
20756A	756	702 (54×13)	(763.6)	14	2

External Dimensions Units: mm

(2) SGLFW-35A

· Coil Assembly: SGLFW-35A□□□A□

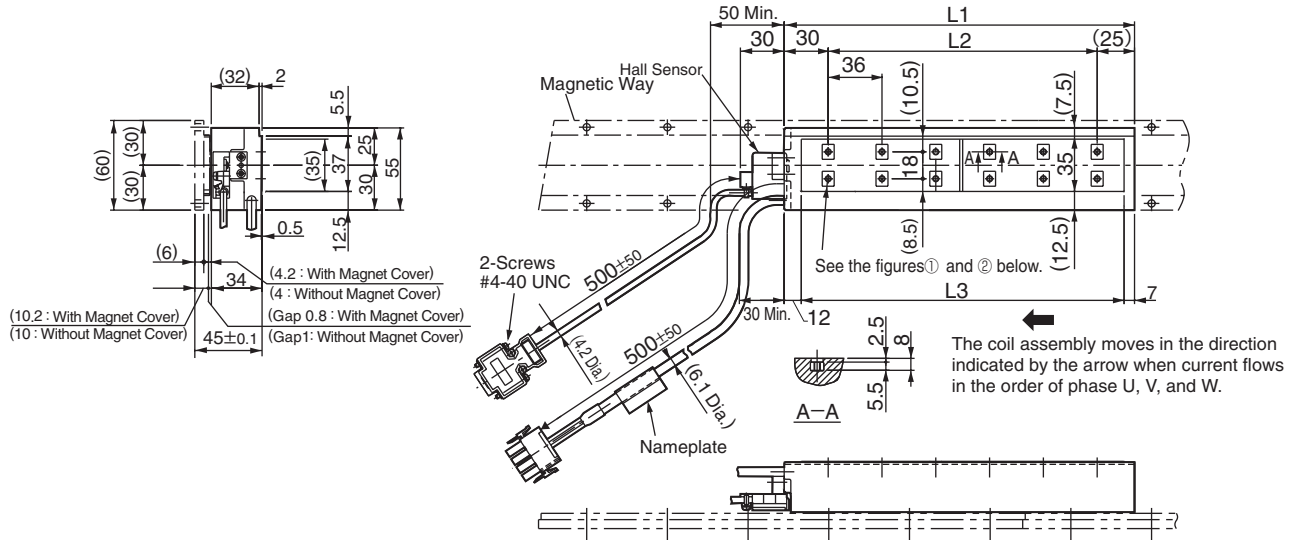

① SGLFW-35A120A□

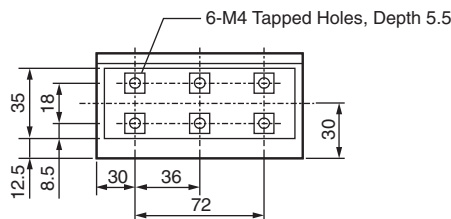

② SGLFW-35A230A□

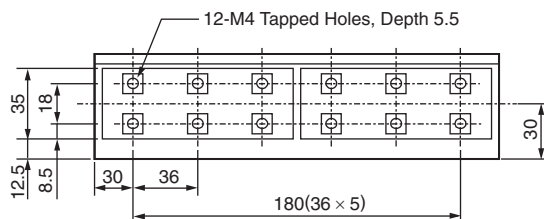

Hall Sensor Connector Specifications

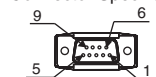

Pin Connector
 17JE-23090-02 (D8C)
 by DDK Ltd.

The Mating Connector

Socket Connector:
 17JE-13090-02(D8C)
 Stud: 17L-002C or
 17L-002C1

Pin No.	Signal
1	+5V (Power supply)
2	Phase U
3	Phase V
4	Phase W
5	0V (Power supply)
6	Not used
7	Not used
8	Not used
9	Not used

Linear Servomotor Connector Specifications



Plug: 350779-1
 Pin : 350218-3 or
 350547-3 (No.1 to 3)
 350654-1
 350669-1 (No.4)
 by Tyco Electronics AMP K.K.

The Mating Connector

Cap : 350780-1
 Socket: 350536-3 or
 350550-3

Pin No.	Signal	Wire Color
1	Phase U	Red
2	Phase V	White
3	Phase W	Black
4	FG	Green

Hall Sensor Output Signals

When the coil assembly moves in the direction indicated by the arrow in the figure, the relationship between the hall sensor output signals S_u , S_v , S_w and the inverse power of each motor phase V_u , V_v , V_w becomes as shown in the figure below.

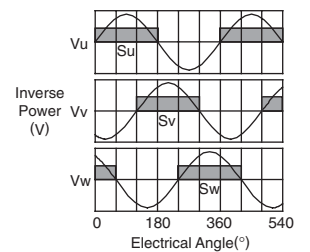

Coil Assembly Model SGLFW-	L1	L2	L3	Approx. Mass kg
35A090A□	127	72	108	1.3
35A120A□	235	180	216	2.3

External Dimensions Units: mm

(3) SGLFW-50A

• Coil Assembly: SGLFW-50A□□□□B□

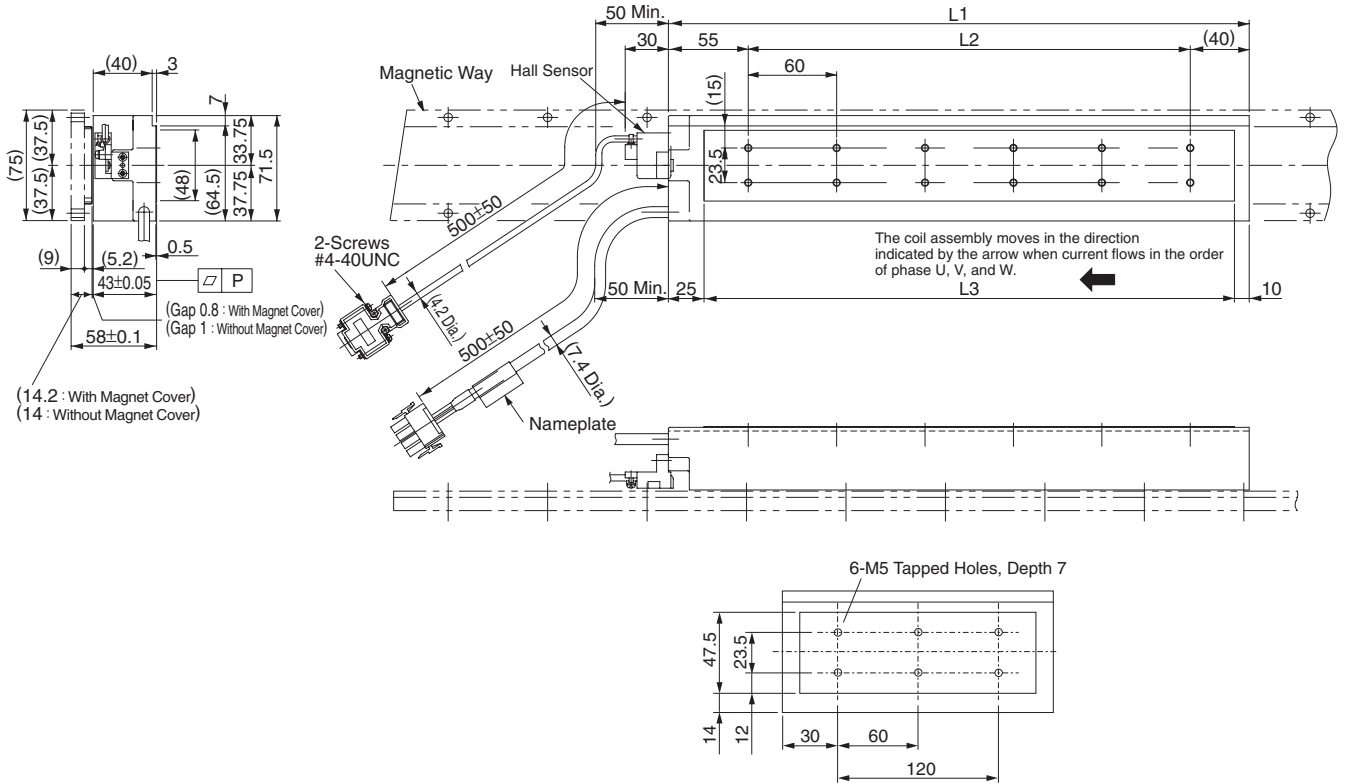

Hall Sensor Connector Specifications

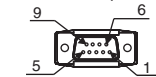

Pin Connector
 17JE-23090-02 (D8C)
 by DDK Ltd.

The Mating Connector

Socket Connector:
 17JE-13090-02(D8C)
 Stud: 17L-002C or
 17L-002C1

Pin No.	Signal
1	+5V (Power supply)
2	Phase U
3	Phase V
4	Phase W
5	0V (Power supply)
6	Not used
7	Not used
8	Not used
9	Not used

Linear Servomotor Connector Specifications

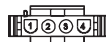

Plug: 350779-1
 Pin : 350218-3 or
 350547-3 (No.1 to 3)
 350654-1
 350669-1 (No.4)
 by Tyco Electronics AMP K.K.

The Mating Connector

Cap : 350780-1
 Socket: 350536-3 or
 350550-3

Pin No.	Signal	Wire Color
1	Phase U	Red
2	Phase V	White
3	Phase W	Black
4	FG	Green

Hall Sensor Output Signals

When the coil assembly moves in the direction indicated by the arrow in the figure, the relationship between the hall sensor output signals S_u , S_v , S_w and the inverse power of each motor phase V_u , V_v , V_w becomes as shown in the figure below.

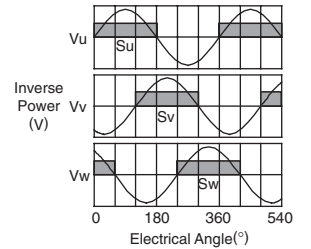

Coil Assembly Model SGLFW-	L1	L2	L3	Flatness P	Approx. Mass kg
50A200B□	215	120	180	0.2	3.5

Selecting Cables

● Cables Connections

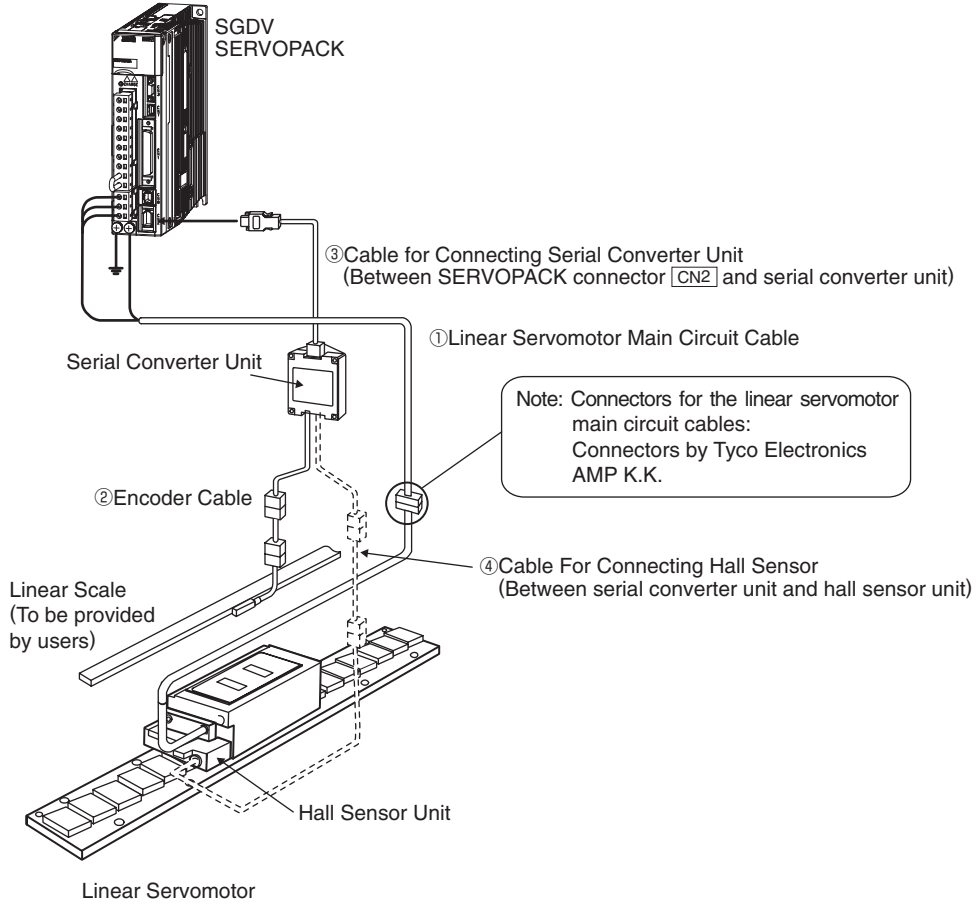

Linear Servomotors

Selecting Cables

Contact Yaskawa Controls Co., Ltd.

●Cables

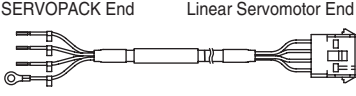
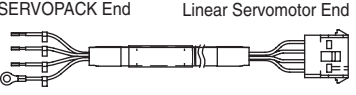
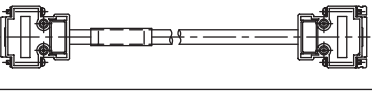
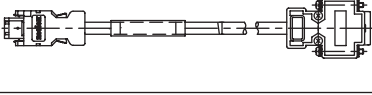
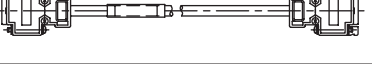
Name	Applicable Linear Servomotor Model	Length	Order No.	Specifications	Details
① Linear Servomotor Main Circuit Cables	SGLFW-20, SGLFW-35	1m	JZSP-CLN11-01-E		(1)
		3m	JZSP-CLN11-03-E		
		5m	JZSP-CLN11-05-E		
		10m	JZSP-CLN11-10-E		
		15m	JZSP-CLN11-15-E		
		20m	JZSP-CLN11-20-E		
	SGLFW-50	1m	JZSP-CLN21-01-E		(2)
		3m	JZSP-CLN21-03-E		
		5m	JZSP-CLN21-05-E		
		10m	JZSP-CLN21-10-E		
		15m	JZSP-CLN21-15-E		
		20m	JZSP-CLN21-20-E		
② Encoder Cables	All models	1m	JZSP-CLL00-01-E		(3)
		3m	JZSP-CLL00-03-E		
		5m	JZSP-CLL00-05-E		
		10m	JZSP-CLL00-10-E		
		15m	JZSP-CLL00-15-E		
③ Cables for Connecting Serial Converter Units	All models	1m	JZSP-CLP70-01-E		(4)
		3m	JZSP-CLP70-03-E		
		5m	JZSP-CLP70-05-E		
		10m	JZSP-CLP70-10-E		
		15m	JZSP-CLP70-15-E		
		20m	JZSP-CLP70-20-E		
④ Cables for Connecting Hall Sensors	All models	1m	JZSP-CLL10-01-E		(5)
		3m	JZSP-CLL10-03-E		
		5m	JZSP-CLL10-05-E		
		10m	JZSP-CLL10-10-E		
		15m	JZSP-CLL10-15-E		

Selecting Cables

(1) Linear Servomotor Main Circuit Cables: JZSP-CLN11-□□-E

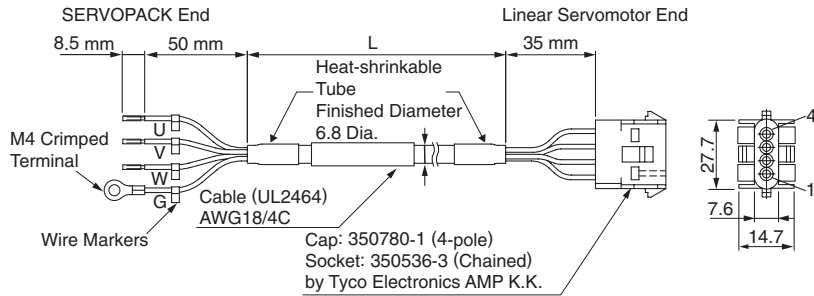

• Wiring Specifications

SERVOPACK-end Leads		Linear Servomotor-end Connector	
Wire Color	Signal	Signal	Pin No.
Red	Phase U	Phase U	1
White	Phase V	Phase V	2
Blue	Phase W	Phase W	3
Green/yellow	FG	FG	4

(2) Linear Servomotor Main Circuit Cables: JZSP-CLN21-□□-E

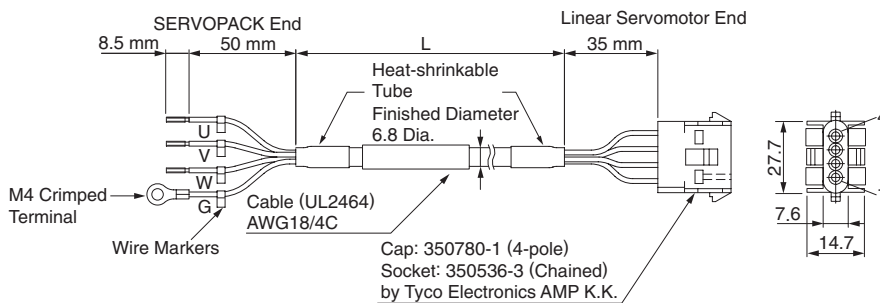

• Wiring Specifications

SERVOPACK-end Leads		Linear Servomotor-end Connector	
Wire Color	Signal	Signal	Pin No.
Red	Phase U	Phase U	1
White	Phase V	Phase V	2
Blue	Phase W	Phase W	3
Green/yellow	FG	FG	4

(3) Encoder Cable: JZSP-CLL00-□□-E

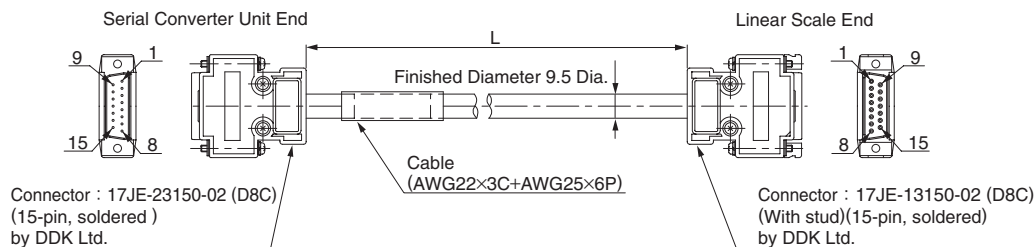

• Wiring Specifications

Serial Converter Unit End		Linear Scale End	
Pin No.	Signal	Pin No.	Signal
1	/Cos(V1-)	1	/Cos(V1-)
2	/Sin(V2-)	2	/Sin(V2-)
3	Ref(V0+)	3	Ref(V0+)
4	+5V	4	+5V
5	5Vs	5	5Vs
6	BID	6	BID
7	Vx	7	Vx
8	Vq	8	Vq
9	Cos(V1+)	9	Cos(V1+)
10	Sin(V2+)	10	Sin(V2+)
11	/Ref(V0+)	11	/Ref(V0-)
12	0V	12	0V
13	0Vs	13	0Vs
14	DIR	14	DIR
15	Inner	15	Inner
Case	Shield	Case	Shield

Selecting Cables

(4) Cables for Connecting Serial Converter Units: JZSP-CLP70-□□-E

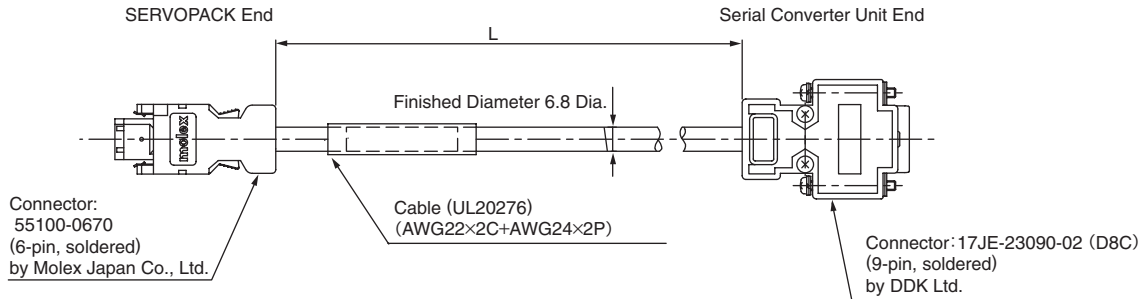

• Wiring Specifications

SERVOPACK End			Serial Converter Unit End		
Pin No.	Signal	Wire Color	Pin No.	Signal	Wire Color
1	PG5V	Red	1	+5V	Red
2	PG0V	Black	5	0V	Black
3	—	—	3	—	—
4	—	—	4	—	—
5	PS	Light blue	2	Phase S output	Light blue
6	/PS	Light blue/white	6	Phase /S output	Light blue/white
Shell	Shield	—	Case	Shield	—
			7	—	—
			8	—	—
			9	—	—

(5) Cables for Connecting Hall Sensors: JZSP-CLL10-□□-E

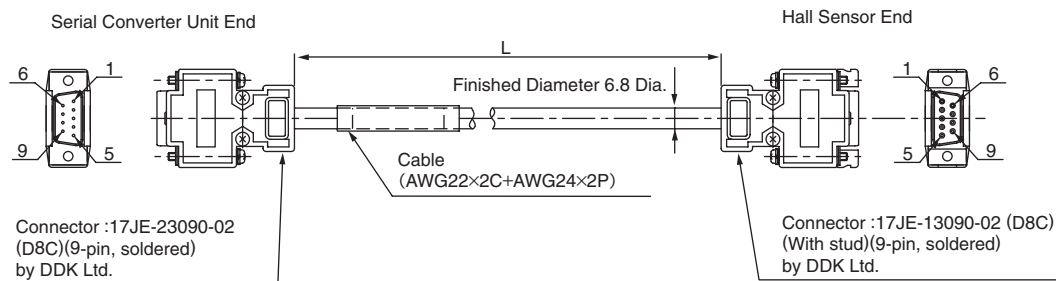

• Wiring Specifications

Serial Converter Unit End		Hall Sensor End	
Pin No.	Signal	Pin No.	Signal
1	+5V	1	+5V
2	Phase U input	2	Phase U input
3	Phase V input	3	Phase V input
4	Phase W input	4	Phase W input
5	0V	5	0V
6	—	6	—
7	—	7	—
8	—	8	—
9	—	9	—
Case	Shield	Case	Shield

Linear Servomotors

SGLTW

(With T-type iron core)

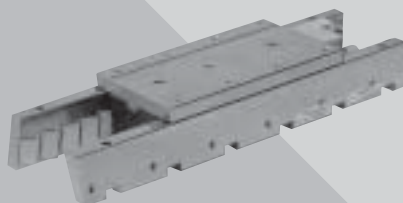

Model Designations

● Coil Assembly

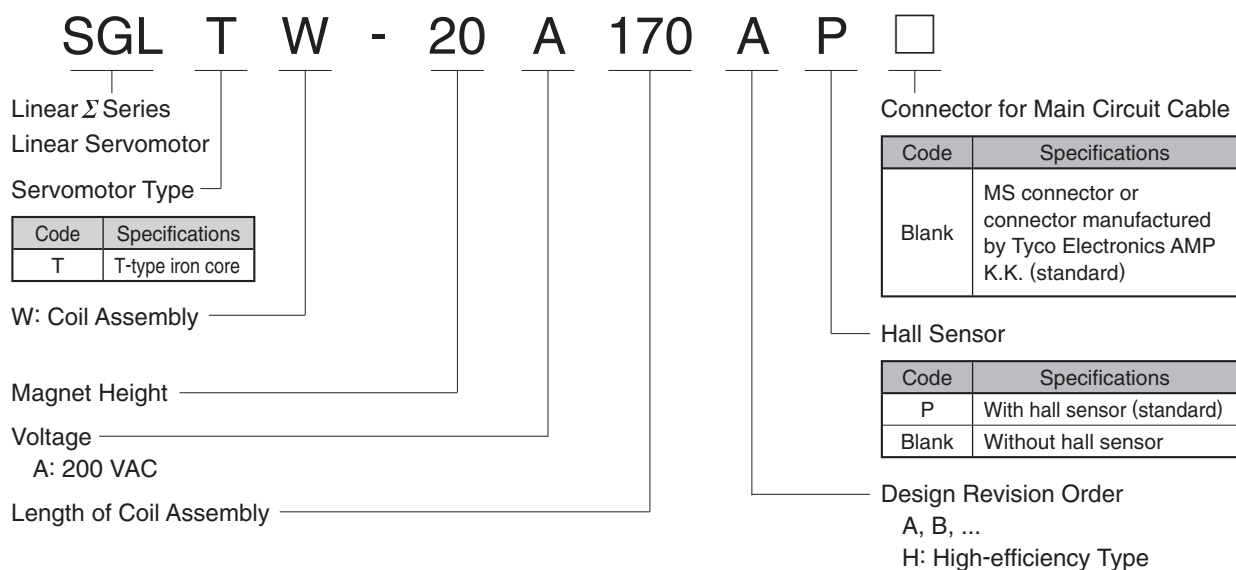

Features

- Direct-feed mechanism for high-speed and high-precision positioning.
- Yaskawa's unique construction principles of the TW linear motors negate the effects of the magnetic attraction force between the relative motor members.
- Lack of magnetic attraction helps to extend the life of the linear motion guides and to minimize operation noise.
- Very little cogging.

Application Examples

- Feeders and loaders
- Mounters
- Machine tools

• Magnetic Way

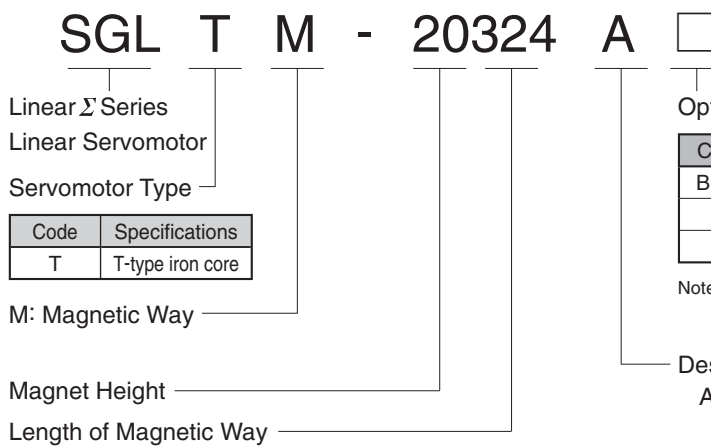

Ratings and Specifications

Time Rating: Continuous

Insulation Resistance: 500 VDC, 10 MΩ min.

Ambient Temperature: 0 to 40°C

Excitation: Permanent magnet

Withstand Voltage: 1500 VAC for one minute

Enclosure: Self-cooled

Ambient Humidity: 20% to 80% (no condensation)

Allowable Winding Temperature: 130°C

(Thermal class B)

Linear Servomotor Model SGLTW- <input type="text"/>		Standard Type		High-efficiency Type	
		20A170A	35A170A	35A170H	50A170H
Rated Speed	m/s	3.0	2.5	2.5	2.0
Peak Speed	m/s	5.0	5.0	4.8	3.2
Rated Force*	N	130	220	300	450
Rated Current*	Arms	2.3	3.5	5.1	4.9
Peak Force*	N	380	660	600	900
Peak Current*	Arms	7.7	12.1	11.9	11.5
Coil Assembly Mass	kg	2.5	3.7	4.9	6
Force Constant	N/Arms	61	67.5	64	98.5
BEMF Constant	V/(m/s)	20.3	22.5	21.3	32.8
Motor Constant	N/√w	18.7	26.7	37.4	50.3
Electrical Time Constant	ms	5.9	6.94	15.1	16.5
Mechanical Time Constant	ms	7.5	5.21	3.3	2.8
Thermal Resistance (With Heat Sink)	K/W	1.01	0.76	0.76	0.61
Thermal Resistance (Without Heat Sink)	K/W	1.82	1.26	1.26	0.97
Magnetic Attraction*1	N	0	0	0	0
Magnetic Attraction(on one side)*2	N	802	1400	1400	2000
Applicable SERVOPACK	SGDV-	3R8A	5R5A	5R5A	5R5A

*1 : The unbalanced magnetic gap resulted from the coil assembly installation condition causes a magnetic attraction on the coil assembly.

*2 : The value indicates the magnetic attraction generated on one side of the magnetic way.

Notes: 1 The items marked with an * and "Force and Speed Characteristics" (the table below) are the values at a motor winding temperature of 100°C during operation in combination with a SERVOPACK. The others are at 20°C.

2 The above specifications show the values under the cooling condition when a heat sink (aluminum board) listed in the following table is mounted on the coil assembly.

Heat Sink Size 254 mm×254 mm×25 mm : SGLTW-20A170A, -35A170A
 400 mm×500 mm×40 mm : SGLTW-35A170H, -50A170H

● Force and Characteristics

A : Continuous Duty Zone **B** : Intermittent Duty Zone

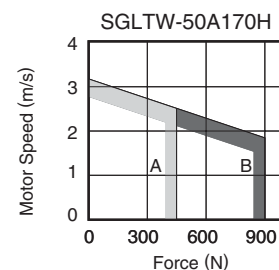
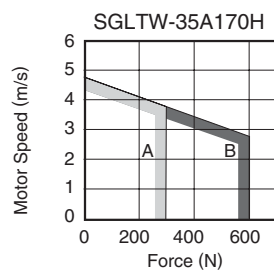
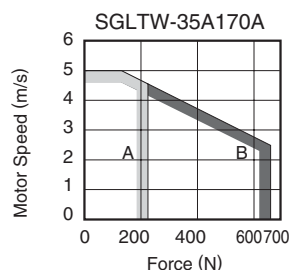
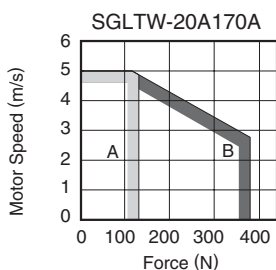

● Mechanical Specifications

(1) Impact Resistance

- Impact acceleration: 196 m/s²
- Impact occurrences: twice

(2) Vibration Resistance

The linear servomotors will withstand the following vibration acceleration in three directions: Vertical, side to side, and front to back.

- Vibration acceleration: 49 m/s²

External Dimensions Units: mm

- Standard Type: SGLTW-20A□□□A□
- Coil Assembly: SGLTW-20A□□□A□

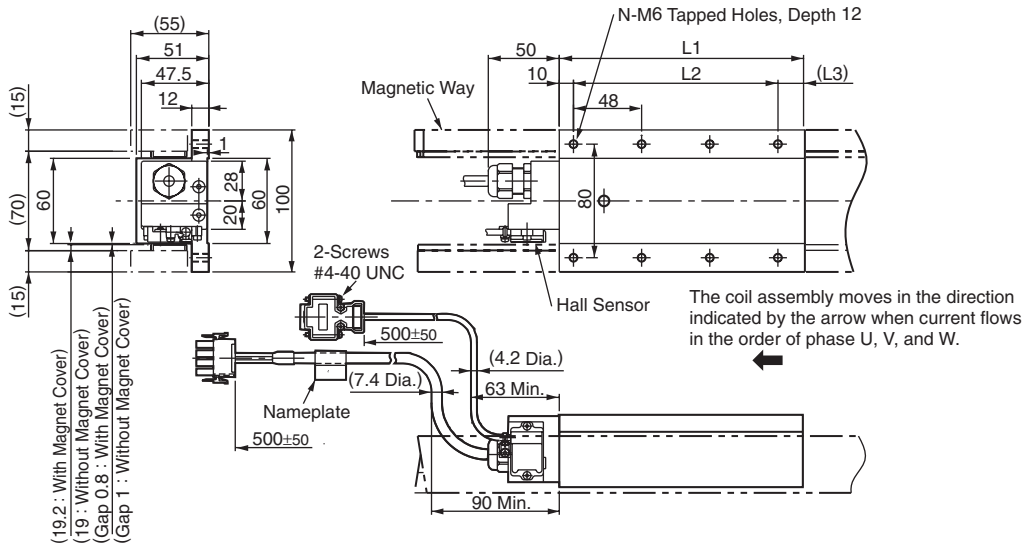

Hall Sensor Connector Specifications

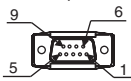

Pin Connector:
 17JE-23090-02 (D8C)
 by DDK Ltd.

The Mating Connector
 Socket Connector:
 17JE-13090-02 (D8C)
 Stud: 17L-002C or
 17L-002C1

Pin No.	Signal
1	+5VDC
2	Phase U
3	Phase V
4	Phase W
5	0V
6	Not used
7	Not used
8	Not used
9	Not used

Linear Servomotor Connector Specifications

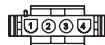

Plug: 350779-1
 Pin : 350218-3 or
 350547-3 (No.1 to 3)
 350654-1
 350669-1 (No.4)
 by Tyco Electronics AMP K.K.

The Mating Connector

Cap : 350780-1
 Socket: 350536-3 or
 350550-3

Pin No.	Signal	Wire Color
1	Phase U	Red
2	Phase V	White
3	Phase W	Black
4	Ground	Green

Hall Sensor Output Signals

When the coil assembly moves in the direction indicated by the arrow in the figure, the relationship between the hall sensor output signals S_u , S_v , S_w and the inverse power of each motor phase V_u , V_v , V_w becomes as shown in the figure below.

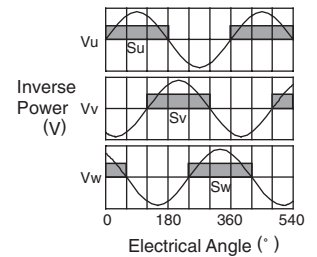

Coil Assembly Model SGLTW-	L1	L2	(L3)	N	Approx. Mass kg
20A170A□	170	144 (48×3)	(16)	8	2.5

External Dimensions Units: mm

• Magnetic Way : SGLTM-20□□□A

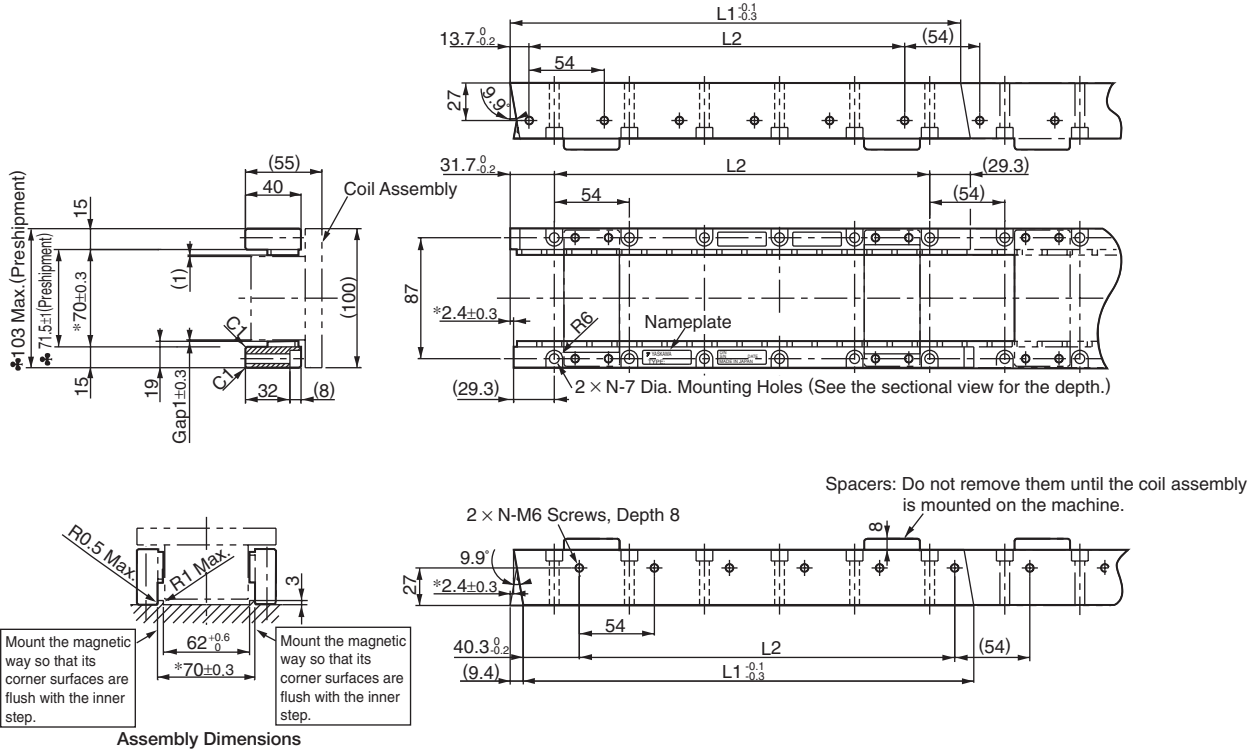

- Notes: 1 Two magnetic ways for both ends of coil assembly make one set. Spacers are mounted on magnetic ways for safety during transportation. Do not remove the spacers until the coil assembly is mounted on a machine.
 2 The magnetic way may affect pacemakers. Keep a minimum distance of 200 mm from the magnetic way.
 3 Two magnetic ways in a set can be connected to each other.
 4 The dimensions marked with an * are the dimensions between the magnetic ways. Be sure to follow exactly the dimensions specified in the figure above. Mount magnetic ways as shown in Assembly Dimensions. The values with a ♣ are the dimensions at preshipment.
 5 Use socket headed screws of strength class 10.9 minimum for magnetic way mounting screws. Do not use stainless steel screws.

Magnetic Way Model SGLTM-	$L1_{-0.3}^{-0.1}$	$L2$	N	Approx. Mass kg
20324A	324	270 (54×5)	6	3.4
20540A	540	486 (54×9)	10	5.7
20756A	756	702 (54×13)	14	7.9

External Dimensions Units: mm

- Magnetic Way with Base: SGLTM-20□□□AY

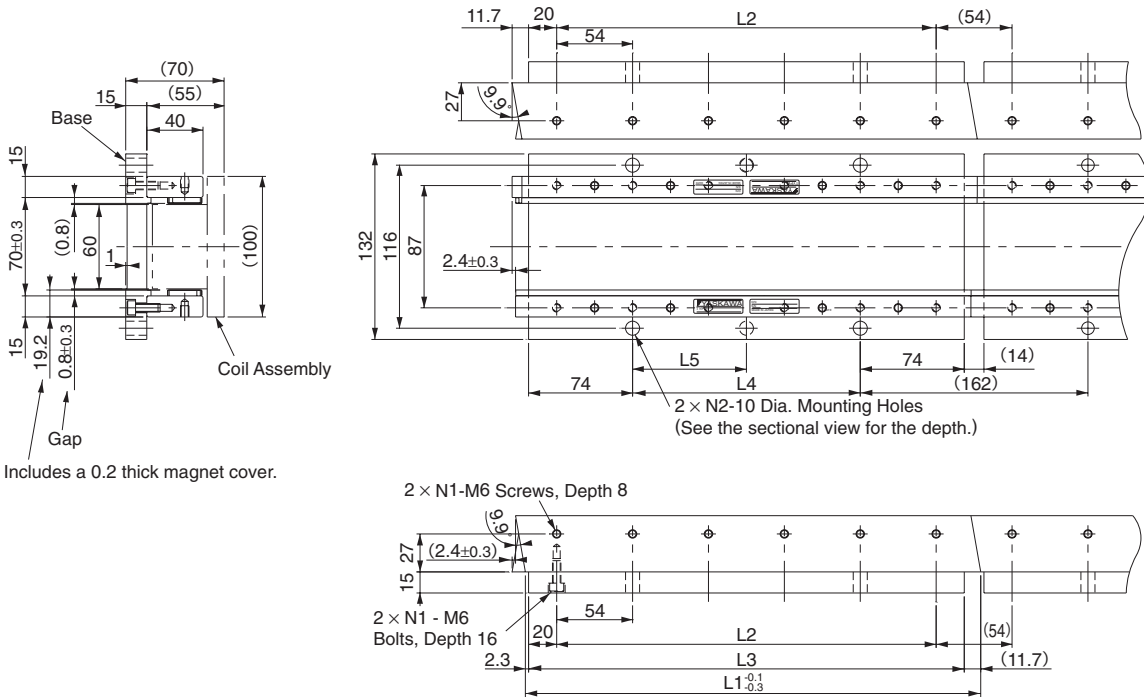

- Notes: 1 The magnetic way may affect pacemakers. Keep a minimum distance of 200 mm from the magnetic way.
 2 Two magnetic ways in a set can be connected to each other.
 3 The characteristics of the magnetic way with base are the same as of the magnetic way without base (SGLTM-20□□□A).

Magnetic Way Model SGLTM-	L1	L2	L3	L4	L5	N1	N2	Approx. Mass kg
20324AY	324	270	310	162	162	6	2	5.1
20540AY	540	486	526	378	189	10	3	8.5
20756AY	756	702	742	594	198	14	4	12

External Dimensions Units: mm

- Standard Type SGLTW-35A□□□A□
- Coil Assembly: SGLTW-35A□□□A□

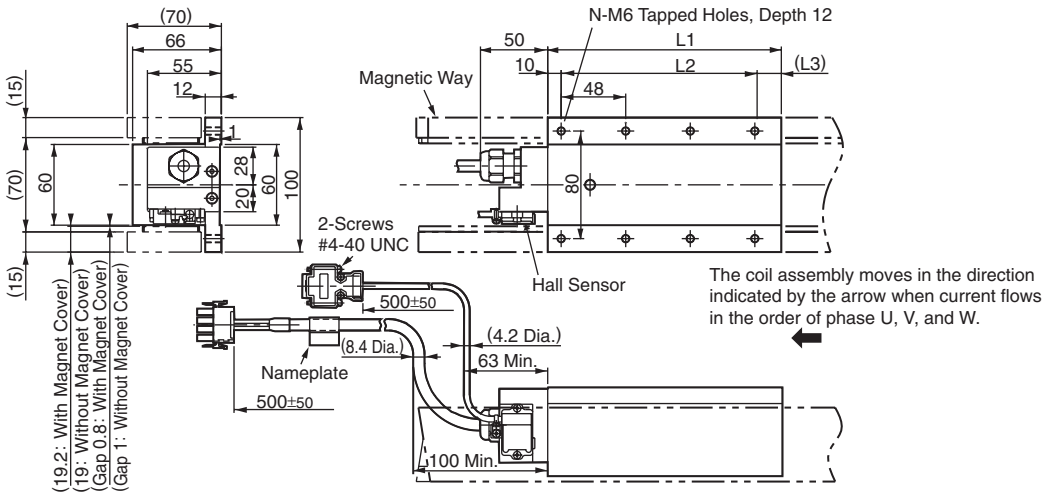

Hall Sensor Connector Specifications

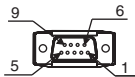

Pin Connector:
17JE-23090-02 (D8C)
by DDK Ltd.

The Mating Connector

Socket Connector:
17JE-13090-02 (D8C)
Stud: 17L-002C or
17L-002C1

Pin No.	Signal
1	+5VDC
2	Phase U
3	Phase V
4	Phase W
5	0V
6	Not used
7	Not used
8	Not used
9	Not used

Linear Servomotor Connector Specifications



Plug: 350779-1
Pin : 350218-3 or
350547-3 (No.1 to 3)
350654-1
350669-1 (No.4)

by Tyco Electronics AMP K.K.

The Mating Connector

Cap : 350780-1
Socket: 350536-3 or
350550-3

Pin No.	Signal	Wire Color
1	Phase U	Red
2	Phase V	White
3	Phase W	Black
4	Ground	Green

Hall Sensor Output Signals

When the coil assembly moves in the direction indicated by the arrow in the figure, the relationship between the hall sensor output signals S_u , S_v , S_w and the inverse power of each motor phase V_u , V_v , V_w becomes as shown in the figure below.

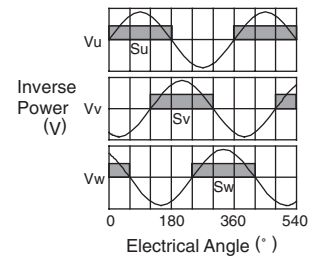

Coil Assembly Model SGLTW-	L1	L2	(L3)	N	Approx. Mass kg
35A170A□	170	144 (48×3)	(16)	8	3.7

External Dimensions Units: mm

• Magnetic Way: SGLTM-35□□□A

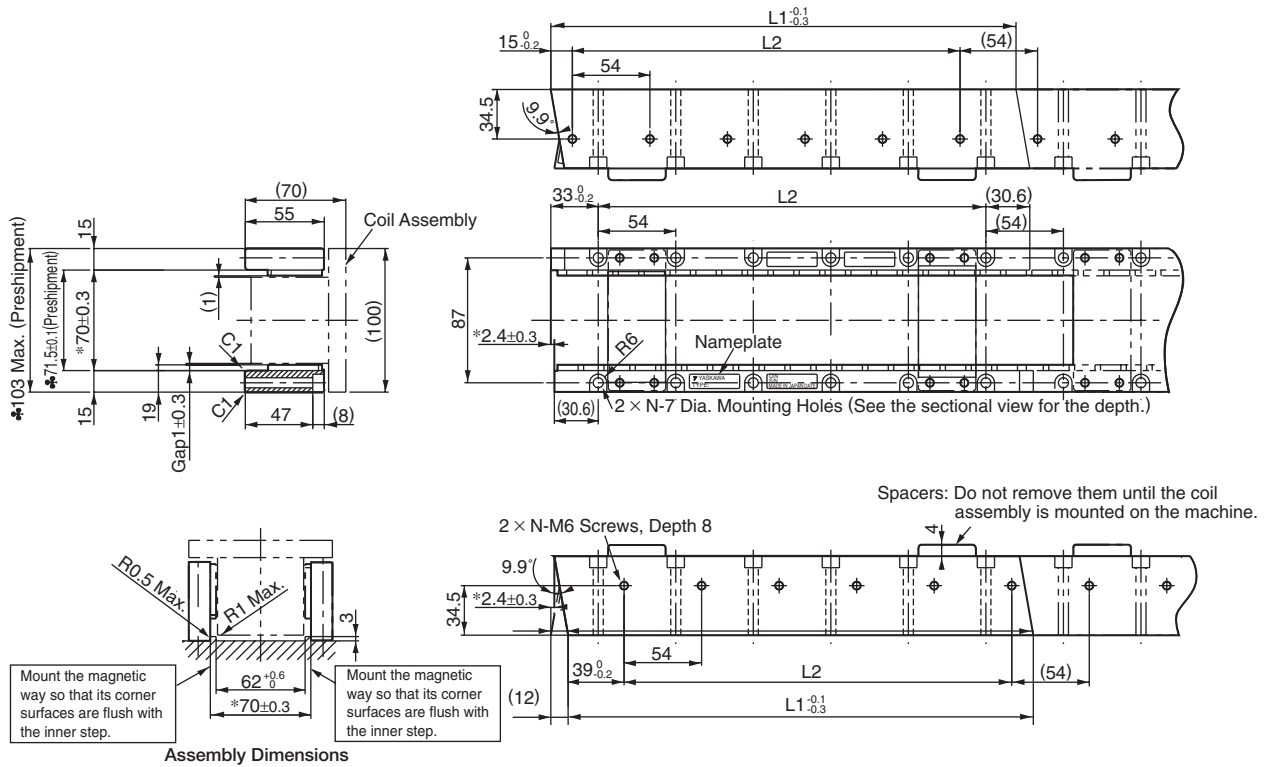

- Notes: 1 Two magnetic ways for both ends of coil assembly make one set. Spacers are mounted on magnetic ways for safety during transportation. Do not remove the spacers until the coil assembly is mounted on a machine.
 2 The magnetic way may affect pacemakers. Keep a minimum distance of 200 mm from the magnetic way.
 3 Two magnetic ways in a set can be connected to each other.
 4 The dimensions marked with an * are the dimensions between the magnetic ways. Be sure to follow exactly the dimensions specified in the figure above. Mount magnetic ways as shown in Assembly Dimensions. The values with a ♣ are the dimensions at preshipment.
 5 Use socket headed screws of strength class 10.9 minimum for magnetic way mounting screws. Do not use stainless steel screws.

Magnetic Way Model SGLTM-	L1 ^{-0.1} _{-0.3}	L2	N	Approx. Mass kg
35324A	324	270 (54×5)	6	4.8
35540A	540	486 (54×9)	10	8
35756A	756	702 (54×13)	14	11

External Dimensions Units: mm

• Magnetic Way with Base: SGLTM-35□□□AY

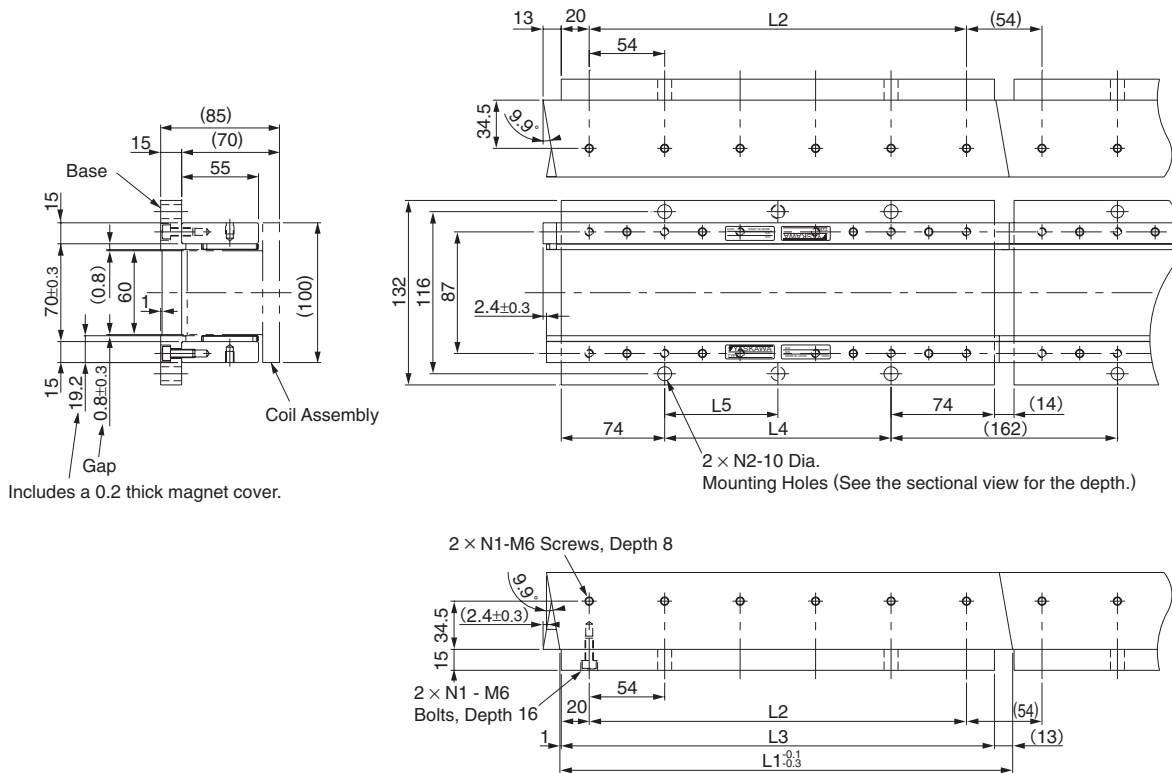

- Notes: 1 The magnetic way may affect pacemakers. Keep a minimum distance of 200 mm from the magnetic way.
 2 Two magnetic ways in a set can be connected to each other.
 3 The characteristics of the magnetic way with base are the same as of the magnetic way without base (SGLTM-35□□□A).

Magnetic Way Model SGLTM-	L1	L2	L3	L4	L5	N1	N2	Approx. Mass kg
35324AY	324	270	310	162	162	6	2	6.4
35540AY	540	486	526	378	189	10	3	11
35756AY	756	702	742	594	198	14	4	15

External Dimensions Units: mm

- High-efficiency Type SGLTW-35A□□□H□
 - Coil Assembly: SGLTW-35A□□□H□

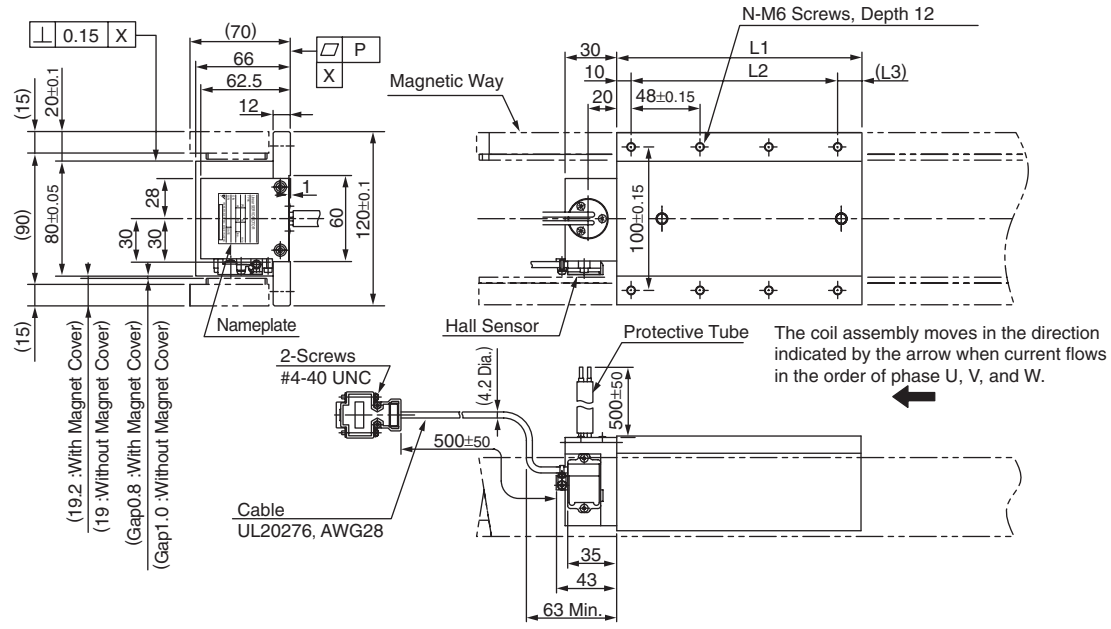

Hall Sensor Connector Specifications

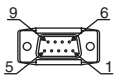

Pin Connector:
 17JE-23090-02 (D8C)
 by DDK Ltd.

The Mating Connector
 Socket Connector:
 17JE-13090-02 (D8C)
 Stud: 17L-002C or
 17L-002C1

Pin No.	Signal
1	+5VDC
2	Phase U
3	Phase V
4	Phase W
5	0V
6	Not used
7	Not used
8	Not used
9	Not used

Lead Specifications of Coil Assembly

· If this cable is bent repetitively, the cable will disconnect.

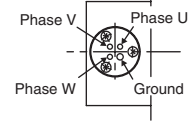

(View from Top of Coil Assembly)

Name	Color	Code	Wire Size
Phase U		U	2 mm ²
Phase V	Black	V	
Phase W		W	
Ground	Green	-	2 mm ²

Hall Sensor Output Signals

When the coil assembly moves in the direction indicated by the arrow in the figure, the relationship between the hall sensor output signals Su, Sv, Sw and the inverse power of each motor phase Vu, Vv, Vw becomes as shown in the figure below.

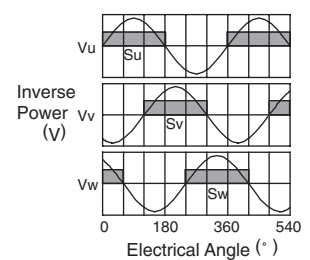

Coil Assembly Model SGLTW-	L1	L2	(L3)	N	Approx. Mass kg
35A170H□	170	144 (48×3)	(16)	8	4.7

External Dimensions Units: mm

• Magnetic Way: SGLTM-35□□□H

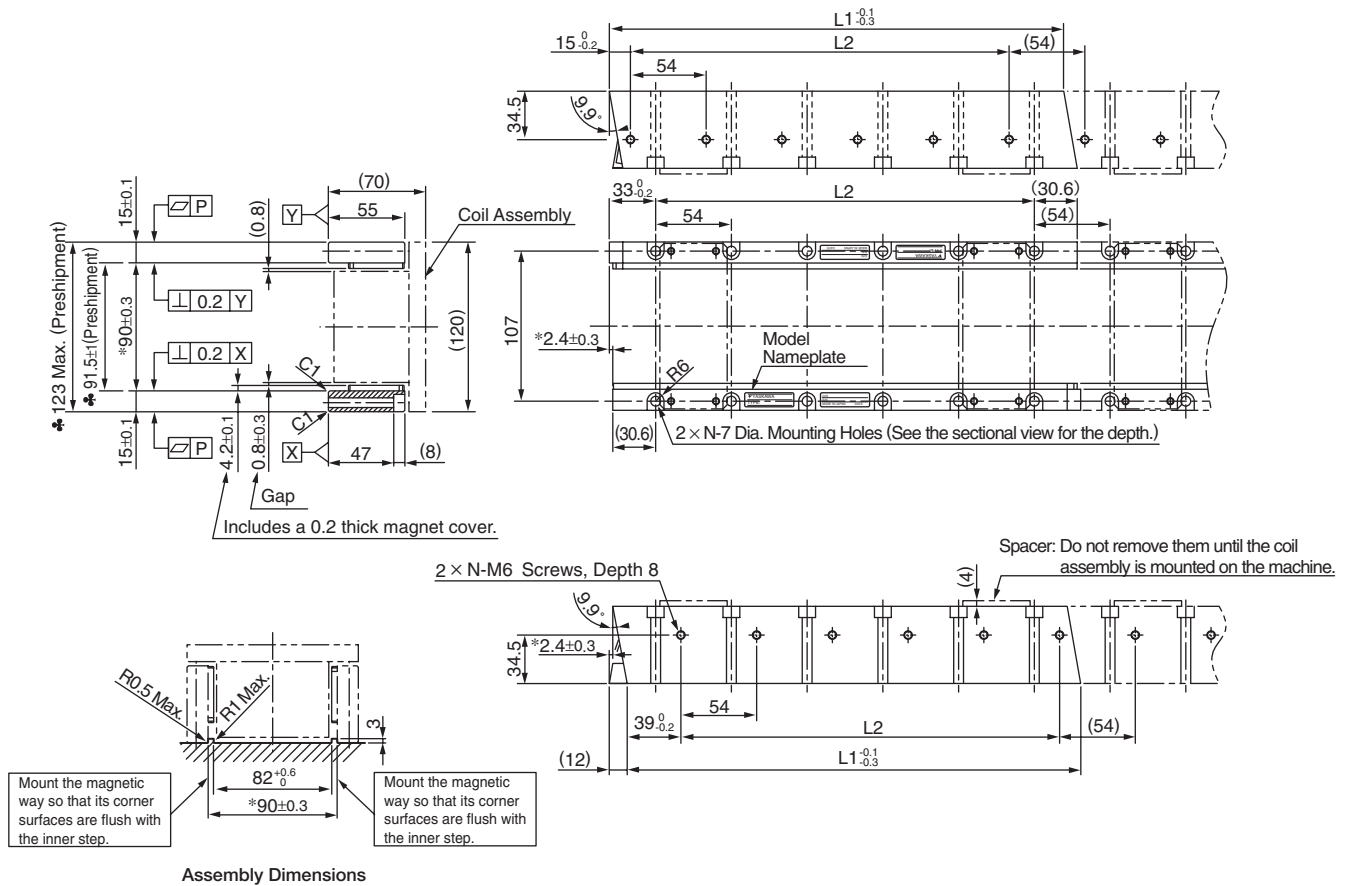

- Notes: 1 Two magnetic ways for both ends of coil assembly make one set. Spacers are mounted on magnetic ways for safety during transportation. Do not remove the spacers until the coil assembly is mounted on a machine.
- 2 The magnetic way may affect pacemakers. Keep a minimum distance of 200 mm from the magnetic way.
- 3 Two magnetic ways in a set can be connected to each other.
- 4 The dimensions marked with an * are the dimensions between the magnetic ways. Be sure to follow exactly the dimensions specified in the figure above. Mount magnetic ways as shown in Assembly Dimensions. The values with a ♣ are the dimensions at preshipment.
- 5 Use socket headed screws of strength class 10.9 minimum for magnetic way mounting screws. Do not use stainless steel screws.

Magnetic Way Model SGLTM-	$L1_{-0.3}^{+0.1}$	$L2$	N	Approx. Mass kg
35324H	324	270 (54×5)	6	4.8
35540H	540	486 (54×9)	10	8
35756H	756	702 (54×13)	14	11

External Dimensions Units: mm

- High-efficiency Type SGLTW-50A□□□H□
 - Coil Assembly: SGLTW-50A□□□H□

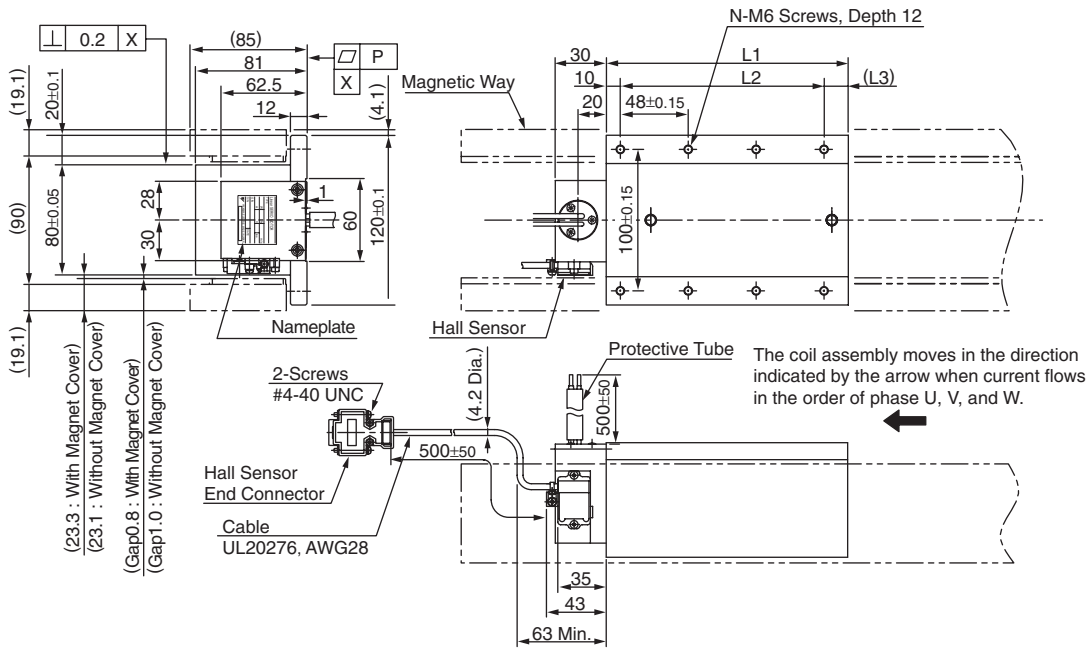

Hall Sensor Connector Specifications

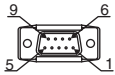

Pin Connector:
 17JE-23090-02 (D8C)
 by DDK Ltd.

The Mating Connector
 Socket Connector:
 17JE-13090-02 (D8C)
 Stud: 17L-002C or
 17L-002C1

Pin No.	Signal
1	+5VDC
2	Phase U
3	Phase V
4	Phase W
5	0V
6	Not used
7	Not used
8	Not used
9	Not used

Lead Specifications of Coil Assembly

- If this cable is bent repetitively, the cable will disconnect.

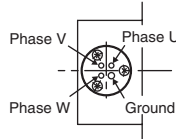

(View from Top of Coil Assembly)

Name	Color	Code	Wire Size
Phase U		U	2 mm ²
Phase V	Black	V	
Phase W		W	
Ground	Green	-	2 mm ²

Hall Sensor Output Signals

When the coil assembly moves in the direction indicated by the arrow in the figure, the relationship between the hall sensor output signals S_u , S_v , S_w and the inverse power of each motor phase V_u , V_v , V_w becomes as shown in the figure below.

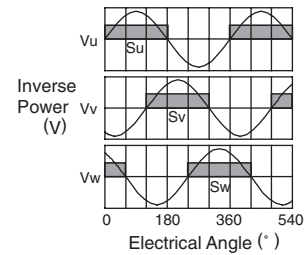

Coil Assembly Model SGLTW-	L1	L2	(L3)	N	Approx. Mass kg
50A170H□	170	144 (48×3)	(16)	8	6

External Dimensions Units: mm

• Magnetic Way: SGLTM-50□□□H

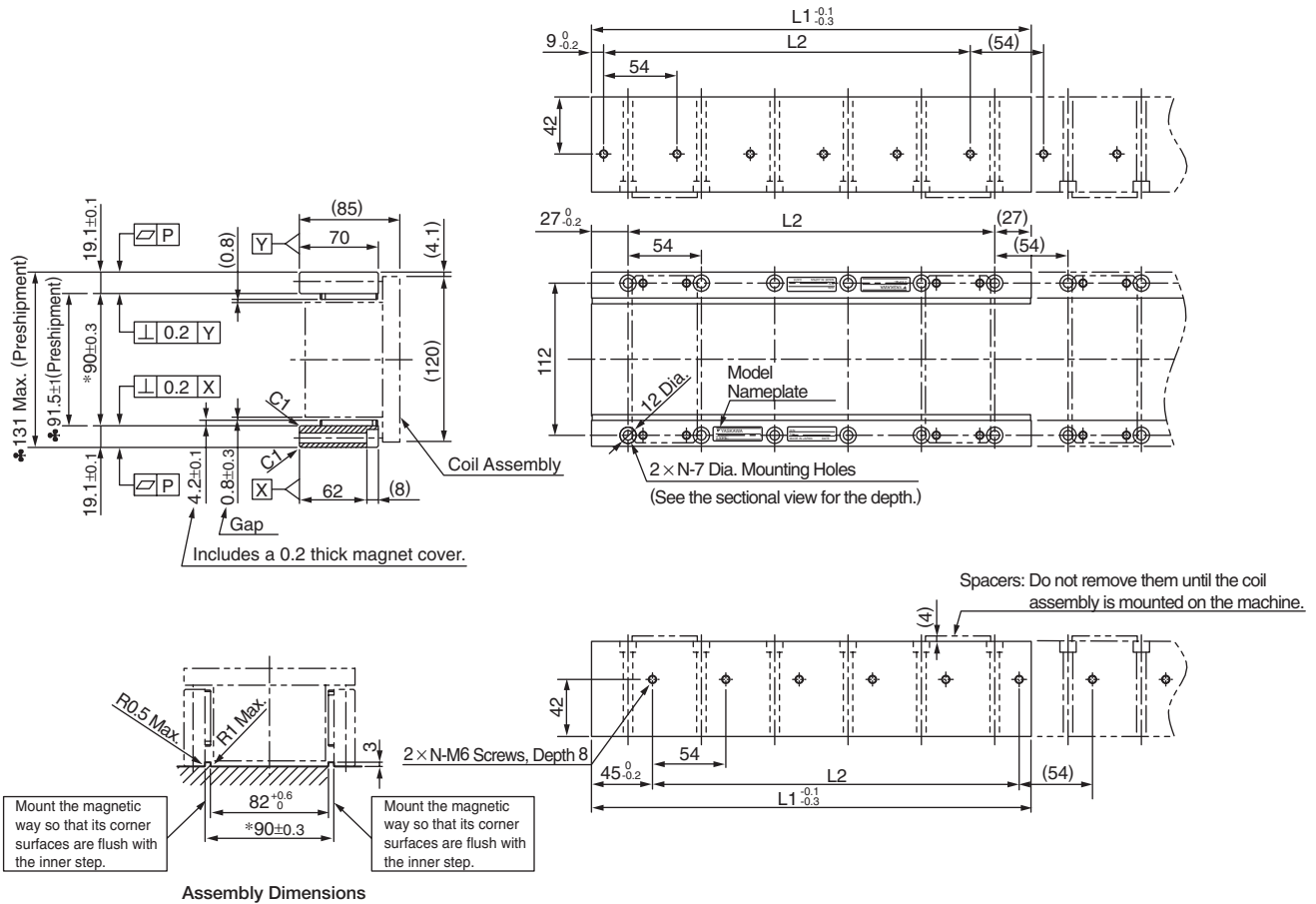

- Notes: 1 Two magnetic ways for both ends of coil assembly make one set. Spacers are mounted on magnetic ways for safety during transportation. Do not remove the spacers until the coil assembly is mounted on a machine.
 2 The magnetic way may affect pacemakers. Keep a minimum distance of 200 mm from the magnetic way.
 3 Two magnetic ways in a set can be connected to each other.
 4 The dimensions marked with an * are the dimensions between the magnetic ways. Be sure to follow exactly the dimensions specified in the figure above. Mount magnetic ways as shown in Assembly Dimensions. The values with a ♣ are the dimensions at preshipment.
 5 Use socket headed screws of strength class 10.9 minimum for magnetic way mounting screws. Do not use stainless steel screws.

Magnetic Way Model SGLTM-	$L1_{-0.3}^{+0.1}$	$L2$	N	Approx. Mass kg
50324HC	324	270 (54×5)	6	8
50540HC	540	486 (54×9)	10	13
50756HC	756	702 (54×13)	14	18

Selecting Cables

● Cables Connections

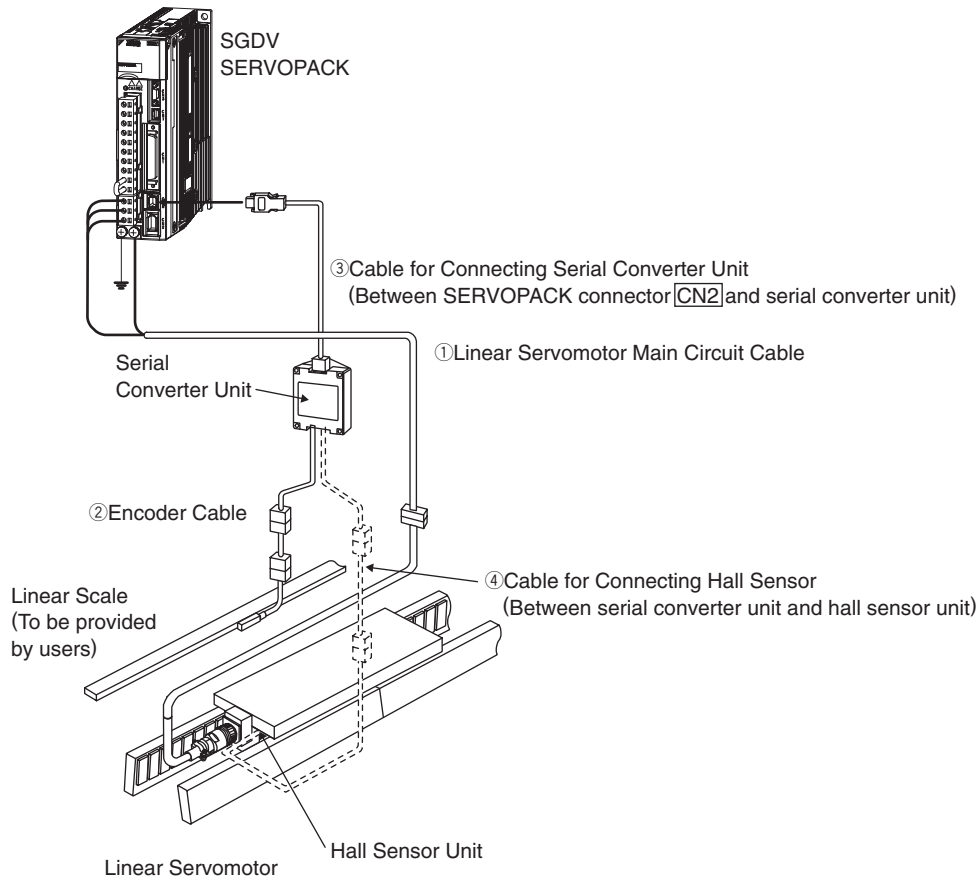

● Cables

Contact Yaskawa Controls Co., Ltd.

Name	Applicable Linear Servomotor Model	Length	Order No.	Specifications	Details
① Linear Servomotor Main Circuit Cables	All models	1 m	JZSP-CLN21-01-E		(1)
		3 m	JZSP-CLN21-03-E		
		5 m	JZSP-CLN21-05-E		
		10 m	JZSP-CLN21-10-E		
		15 m	JZSP-CLN21-15-E		
		20 m	JZSP-CLN21-20-E		
② Encoder Cables	All models	1 m	JZSP-CLL00-01-E		(2)
		3 m	JZSP-CLL00-03-E		
		5 m	JZSP-CLL00-05-E		
		10 m	JZSP-CLL00-10-E		
		15 m	JZSP-CLL00-15-E		
③ Cables for Connecting Serial Converter Units	All models	1 m	JZSP-CLP70-01-E		(3)
		3 m	JZSP-CLP70-03-E		
		5 m	JZSP-CLP70-05-E		
		10 m	JZSP-CLP70-10-E		
		15 m	JZSP-CLP70-15-E		
		20 m	JZSP-CLP70-20-E		
④ Cables for Connecting Hall Sensors	All models	1 m	JZSP-CLL10-01-E		(4)
		3 m	JZSP-CLL10-03-E		
		5 m	JZSP-CLL10-05-E		
		10 m	JZSP-CLL10-10-E		
		15 m	JZSP-CLL10-15-E		

Selecting Cables

(1) Linear Servomotor Main Circuit Cables: JZSP-CLN21-□□-E

· Wiring Specifications

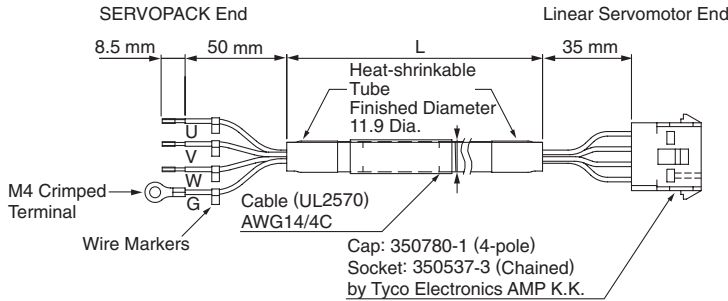

SERVOPACK-end Leads

Wire Color	Signal
Red	Phase U
White	Phase V
Blue	Phase W
Green/yellow	FG

Linear Servomotor-end Connector

Signal	Pin No.
Phase U	1
Phase V	2
Phase W	3
FG	4

(2) Encoder Cables: JZSP-CLL00-□□-E

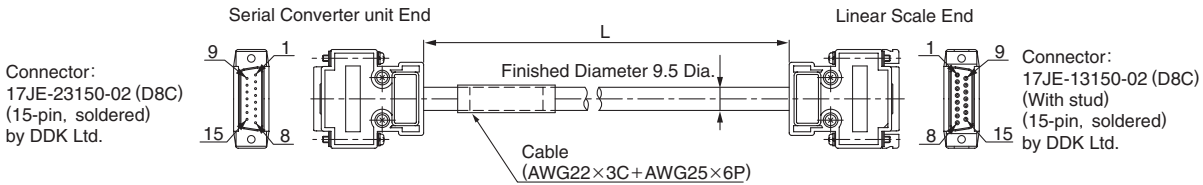

· Wiring Specifications

Serial Converter Unit End		Linear Scale End	
Pin No.	Signal	Pin No.	Signal
1	/Cos(V1-)	1	/Cos(V1-)
2	/Sin(V2-)	2	/Sin(V2-)
3	Ref(V0+)	3	Ref(V0+)
4	+5V	4	+5V
5	5Vs	5	5Vs
6	BID	6	BID
7	Vx	7	Vx
8	Vq	8	Vq
9	Cos(V1+)	9	Cos(V1+)
10	Sin(V2+)	10	Sin(V2+)
11	/Ref(V0+)	11	/Ref(V0-)
12	0V	12	0V
13	0Vs	13	0Vs
14	DIR	14	DIR
15	Inner	15	Inner
Case	Shield	Case	Shield

Selecting Cables

(3) Cables for Connecting Serial Converter Units: JZSP-CLP70-□□-E

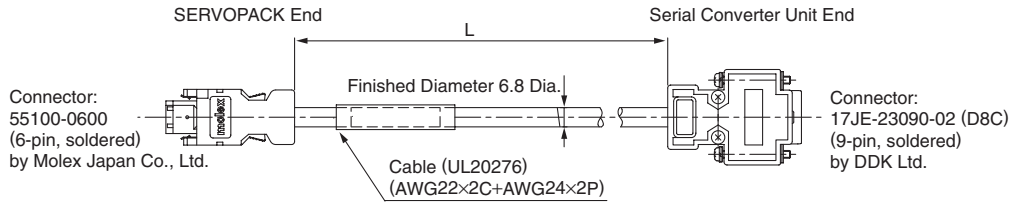

• Wiring Specifications

SERVOPACK End			Serial Converter Unit End		
Pin No.	Signal	Wire Color	Pin No.	Signal	Wire Color
1	PG5V	Red	1	+5V	Red
2	PG0V	Black	5	0V	Black
3	-	-	3	-	-
4	-	-	4	-	-
5	PS	Light blue	2	Phase S output	Light blue
6	/PS	Light blue/white	6	Phase /S output	Light blue/white
Shell	Shield	-	Case	Shield	-
			7	-	-
			8	-	-
			9	-	-

(4) Cables for Connecting Hall Sensors: JZSP-CLL10-□□-E

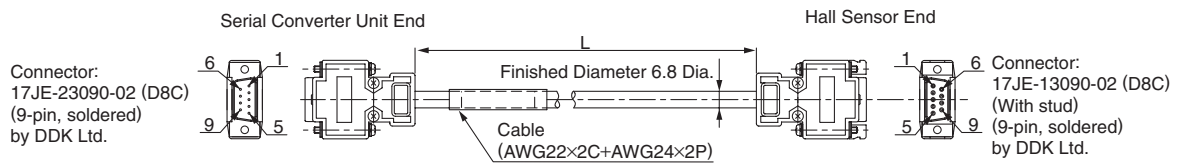

• Wiring Specifications

Serial Converter Unit End		Hall Sensor End	
Pin No.	Signal	Pin No.	Signal
1	+5V	1	+5V
2	Phase U input	2	Phase U input
3	Phase V input	3	Phase V input
4	Phase W input	4	Phase W input
5	0V	5	0V
6	-	6	-
7	-	7	-
8	-	8	-
9	-	9	-
Case	Shield	Case	Shield

Linear Servomotors

Linear Servomotors

SGLCW

(Cylinder Type)



Model Designations

● Coil Assembly

SGL C W - D16 A 085 A P

Linear Σ Series
Linear Servomotor
Servomotor Model

Code	Specifications
C	Cylinder type

W : Coil assembly

Outer Diameter of Magnetic Way

D16 : 16 mm D20 : 20 mm
D25 : 25 mm D32 : 32 mm

Voltage

A : 200 VAC

Hall Sensor
P : With hall sensor (all models)

Design Revision Order
A, B...

Length of Coil Assembly

Outer Diameter of Magnetic Way Code	Length of Coil Assembly Code	Length of Coil Assembly mm	Outer Diameter of Magnetic Way Code	Length of Coil Assembly Code	Length of Coil Assembly mm
D16	085	85	D25	125	125
	115	115		170	170
	145	145		215	215
D20	100	100	D32	165	165
	135	135		225	225
	170	170		285	285

● Magnetic Way

SGL C M - D16 300 A

Linear Σ Series
Linear Servomotor
Servomotor Model

Code	Specifications
C	Cylinder type

M : Magnetic way

Design Revision Order
A, B...

Length of Magnetic Way
(See the next page)

Outer Diameter of Magnetic Way
D16 : 16 mm D20 : 20 mm
D25 : 25 mm D32 : 32 mm

Features

- Both coil assemblies supported, easy switching from ball screws.
- Compared to ball screw systems, high-speed and high-precision positioning greatly reduces tact time.
- Unlike ball screws, no contact with machines, no lubrication oil, easy maintenance.

Application Examples

- Semiconductor equipment
- Electronic parts assembly
- Food packaging machines
- Metal processing machines
- General handling machines

◆Magnetic Way Lengths

Coil Assembly Model SGLCW-		Manufacturing Coil Assembly Dimensions mm					Manufacturing Coil Assembly-Available Length (on request) Length of Magnetic Way mm Min. Length to Max. Length
		Standard Specifications				Code=① Length of Magnetic Way mm	
		② Length of Coil Assembly	③ Position of Support Section	④ Range Outside the Guaranteed Force	⑤ Effective Strokes		
D16A	085AP 115AP 145AP	300	85	30	37.5	140	240 to 420 (30 mm increments)
			115			110	
			145			80	
	510	85	45	52.5	320	480 to 750 (30 mm increments)	
		115			290		
		145			260		
		85			560		
		115			530		
		145			500		
D20A	100AP 135AP 170AP	350	100	35	45	160	280 to 490 (35 mm increments)
			135			125	
			170			90	
	590	100	50	60	370	555 to 870 (35 mm increments)	
		135			335		
		170			300		
		100			650		
		135			615		
		170			580		
D25A	125AP 170AP 215AP	450	125	45	57.5	210	360 to 630 (45 mm increments)
			170			165	
			215			120	
	750	125	60	72.5	480	705 to 1110 (45 mm increments)	
		170			435		
		215			390		
		125			840		
		170			795		
		215			750		
D32A	165AP 225AP 285AP	600	165	60	75	285	480 to 840 (60 mm increments)
			225			225	
			285			165	
	1020	165	90	105	645	960 to 1500 (60 mm increments)	
		225			585		
		285			525		
		165			1125		
		225			1065		
		285			1005		

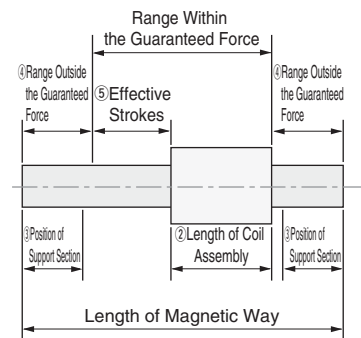

Note: ① Range outside the guaranteed force:
If any part of the coil assembly is located within this range, characteristics indicated in "Force and Speed Characteristics" on page 134 cannot be satisfied.

< Calculating Length of Coil Assembly >

- ② Length of Coil Assembly (mm)
- ④ Range Outside the Guaranteed Force (mm)
- ⑤ Effective Strokes (mm)

Formula

◆Length of Magnetic Way

$$[② + ④ \times 2 + ⑤] \text{ (mm)}$$

Ratings and Specifications

Time Rating: Continuous
 Insulation Resistance: 500 VDC, 10 M Ω min.
 Ambient Temperature: 0 to 40°C
 Excitation: Permanent magnet

Withstand Voltage: 1500 VAC for one minute
 Enclosure: Self-cooled
 Ambient Humidity: 20% to 80% (no condensation)
 Allowable Winding Temperature: 130°C
 (Thermal class B)

Linear Servomotor Model SGLCW-		D16A			D20A			D25A			D32A		
		085A	115A	145A	100A	135A	170A	125A	170A	215A	165A	225A	285A
Peak Speed* ³	m / s	4.0	4.0	4.0	4.0	4.0	4.0	4.0	4.0	4.0	4.0	4.0	4.0
Rated Force* ¹	N	17	25	34	30	45	60	70	105	140	90	135	180
Rated Current* ¹	Arms	0.59	0.58	0.71	0.98	0.98	1.19	1.42	1.75	3.49	1.57	2.79	2.79
Instantaneous Peak Force* ¹	N	60	90	120	150	225	300	280	420	560	420	630	840
Instantaneous Peak Current* ¹	Arms	2.07	2.07	2.52	4.90	4.90	5.95	5.68	6.48	13.97	7.32	13.01	13.01
Coil Assembly Mass	kg	0.3	0.4	0.5	0.6	0.8	1.0	1.0	1.4	1.8	1.8	2.5	3.2
Force Constant	N / Arms	31.2	46.8	51.3	33.0	49.5	54.3	53.1	64.8	43.2	61.8	52.2	69.6
BEMF Constant	V / (m/s)	10.4	15.6	17.1	11.0	16.5	18.1	17.7	21.6	14.4	20.6	17.4	23.2
Motor Constant	N / \sqrt{w}	4.8	5.9	6.7	7.5	9.2	10.4	10.0	12.4	15.4	16.2	20.0	23.0
Electrical Time Constant	ms	0.24	0.18	0.26	0.22	0.32	0.41	0.18	0.59	2.32	0.76	1.18	1.58
Mechanical Time Constant	ms	13.1	11.7	11.3	10.70	9.50	9.30	10.1	9.2	7.6	6.9	6.3	6.0
Thermal Resistance With Heat Sink	K / W	3.35	2.9	1.64	1.66	1.45	1.29	1.00	0.68	0.61	0.77	0.53	0.48
Thermal Resistance Without Heat Sink	K / W	6.79	5.24	4.26	4.35	3.38	2.76	2.99	2.29	1.81	1.87	1.43	1.16
Magnetic Attraction* ²	N	0	0	0	0	0	0	0	0	0	0	0	0
Applicable SERVOPACK	SGDV-	R70A	R70A	R90A	1R6A	1R6A	1R6A	1R6A	2R8A	5R5A	2R8A	5R5A	5R5A

*1: These items and "Force and Speed Characteristics" are the values at a motor winding temperature of 100°C during operation in combination with a SERVOPACK. The others are at 20°C.

*2: Logical magnetic attraction acting between the coil assembly and the magnetic way. Because of the gap imbalance created after installing the coil assembly and the magnetic way, a magnetic attraction is generated.

*3: If an SGLCW linear servomotor is used, the rated speed during operation by speed control with an analog voltage reference must be set to 1.5 m/s.

Note: These specifications show the values under the cooling conditions when a heat sink (aluminum board) listed in the following table is mounted on the coil assembly.

Linear Servomotor Model SGLCW-	Heat Sink Size mm
D16A085A D16A115A	100×200×12
D16A145A D20A100A D20A135A D20A170A	200×300×12
D25A125A D32A165A	300×400×12
D25A170A D25A215A D32A225A D32A285A	400×500×12

Ratings and Specifications

● **Force and Speed Characteristics** **A** : Continuous Duty Zone **B** : Intermittent Duty Zone

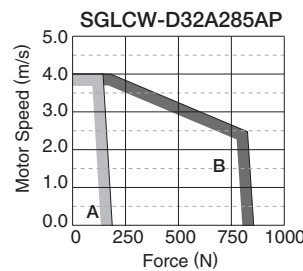
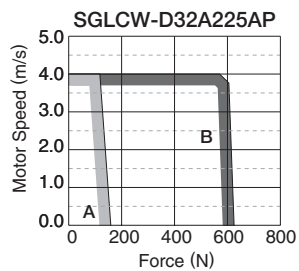
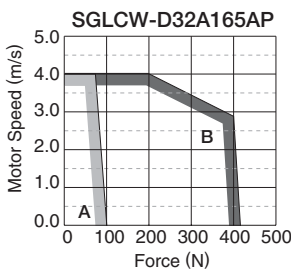
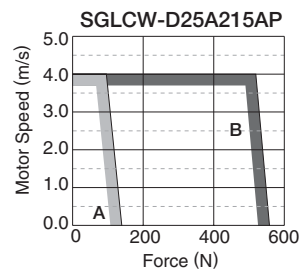
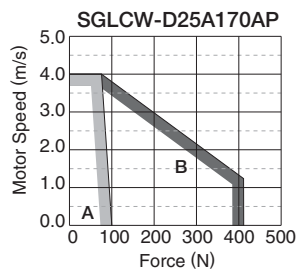
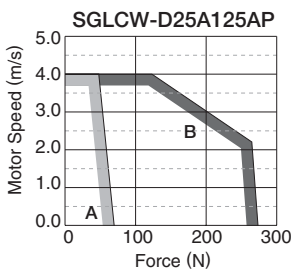
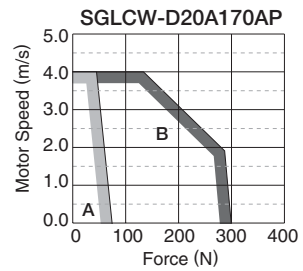
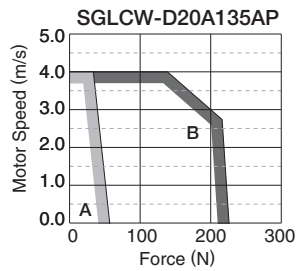
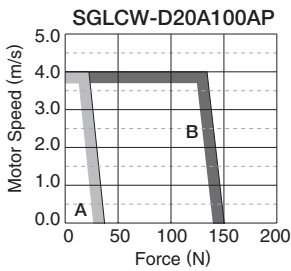
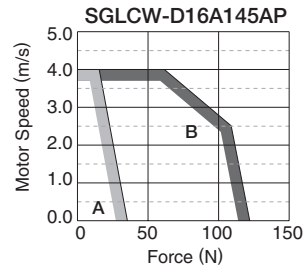
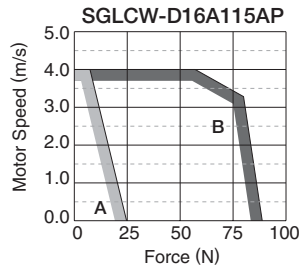
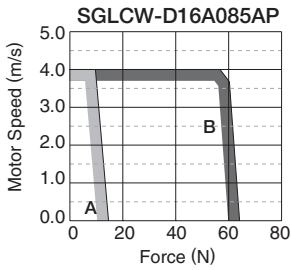

● **Mechanical Specifications of Linear Servomotors**

(1) **Impact Resistance**

- Impact acceleration: 98 m/s²
- Impact occurrences: twice

(2) **Vibration Resistance**

The linear servomotors will withstand the following vibration acceleration in three directions: Vertical, side to side, and front to back.

- Vibration acceleration: 24.5 m/s² (coil assembly), 4.9 m/s² (magnetic way)

External Dimensions Units: mm

● SGLCW-D16

(1) Coil Assembly: SGLCW-D16A□□□AP

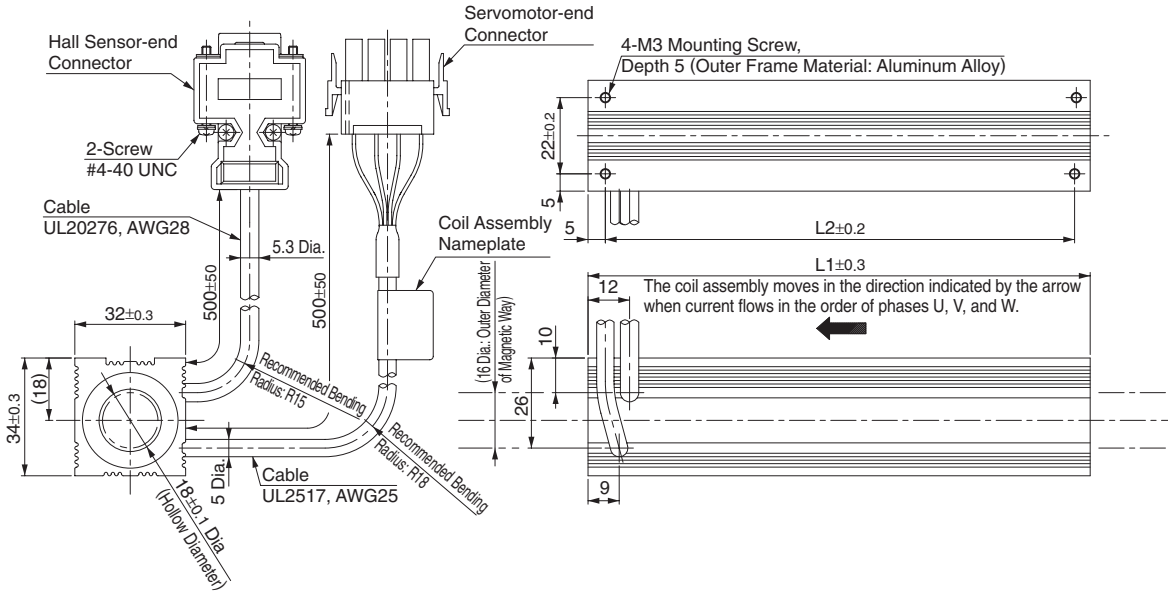

Hall Sensor Connector Specifications

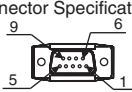

Pin Connector:
17JE-23090-02 (D8C)
by DDK Ltd.

The Mating Connector

Socket Connector:
17JE-13090-02 (D8C)
Stud: 17L-002C or
17L-002C1

Pin No.	Name
1	+5V (Power supply)
2	Phase U
3	Phase V
4	Phase W
5	0V (Power supply)
6	Not used
7	Not used
8	Not used
9	Not used

Linear Servomotor Connector Specifications

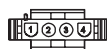

Plug: 350779-1
Pin : 350561-3 or
350690-3 (No.1 to 3)
770210-1 (No.4)

by Tyco
Electronics AMP K.K.
The Mating Connector

Cap: 350780-1
Socket: 350925-1 or
770673-1

Pin No.	Name	Wire Color
1	Phase U	Red
2	Phase V	White
3	Phase W	Blue
4	FG	Green

Hall Sensor Output Signals

When the coil assembly moves in the direction indicated by the arrow in the figure, the relationship between the hall sensor output signals S_u , S_v , S_w and the inverse power of each motor phase V_u , V_v , V_w becomes as shown in the figure below.

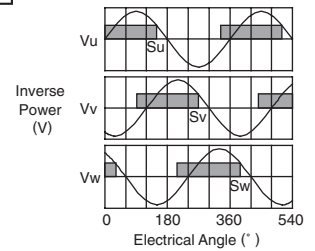

Coil Assembly Model SGLCW-	L1	L2	Approx. Mass* kg
D16A085AP	85	75	0.3
D16A115AP	115	105	0.4
D16A145AP	145	135	0.5

*: The values indicate the mass of coil assembly with a hall sensor unit.

External Dimensions Units: mm

(2) Magnetic Way: SGLCM-D16□□□A

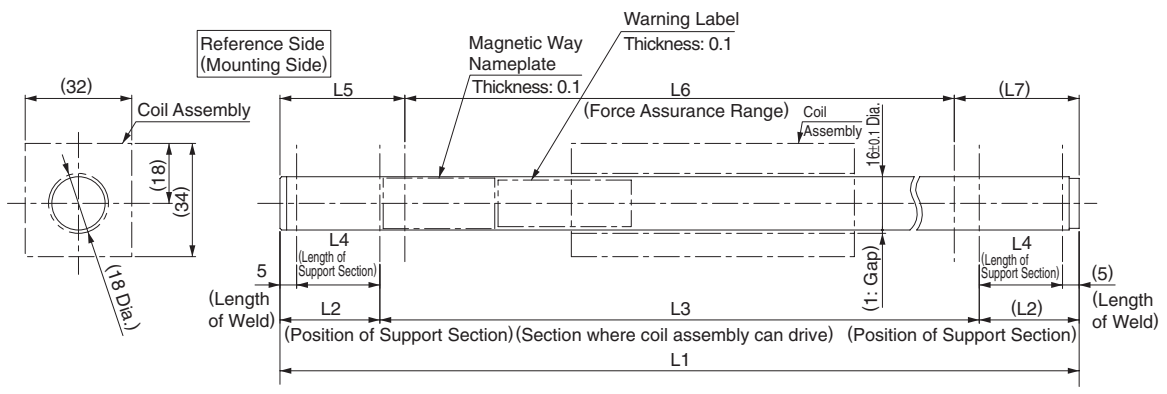

Notes: 1 The magnetic way will become deformed if a magnetic attraction with the coil assembly is generated. Take measures over the entire driving range to prevent any interference between the magnetic way and the coil assembly after installation.
 2 The magnetic way may affect pacemakers. Keep a minimum distance of 200 mm from the magnetic way.

Magnetic Way Model SGLCM-	L1	L2	L3	L4	L5	L6	L7	Approx. Mass kg	Remarks
D16240A	240±1.6	30	180	25	37.5±0.3	165±1.2	37.5	0.38	Standard
D16270A	270±1.6	30	210	25	37.5±0.3	195±1.2	37.5	0.43	
D16300A	300±1.6	30	240	25	37.5±0.3	225±1.2	37.5	0.48	
D16330A	330±1.6	30	270	25	37.5±0.3	255±1.2	37.5	0.53	
D16360A	360±1.6	30	300	25	37.5±0.3	285±1.2	37.5	0.58	
D16390A	390±1.6	30	330	25	37.5±0.3	315±1.2	37.5	0.63	
D16420A	420±1.6	30	360	25	37.5±0.3	345±1.2	37.5	0.68	
D16480A	480±2.5	45	390	40	52.5±0.3	375±2.1	52.5	0.75	
D16510A	510±2.5	45	420	40	52.5±0.3	405±2.1	52.5	0.80	
D16540A	540±2.5	45	450	40	52.5±0.3	435±2.1	52.5	0.85	
D16570A	570±2.5	45	480	40	52.5±0.3	465±2.1	52.5	0.90	
D16600A	600±2.5	45	510	40	52.5±0.3	495±2.1	52.5	0.95	
D16630A	630±2.5	45	540	40	52.5±0.3	525±2.1	52.5	1.0	
D16660A	660±2.5	45	570	40	52.5±0.3	555±2.1	52.5	1.05	
D16690A	690±2.5	45	600	40	52.5±0.3	585±2.1	52.5	1.1	
D16720A	720±2.5	45	630	40	52.5±0.3	615±2.1	52.5	1.15	
D16750A	750±3	45	660	40	52.5±0.3	645±2.5	52.5	1.2	Standard

Linear Servomotors

External Dimensions Units: mm

● SGLCW-D20

(1) Coil Assembly: SGLCW-D20A□□□AP

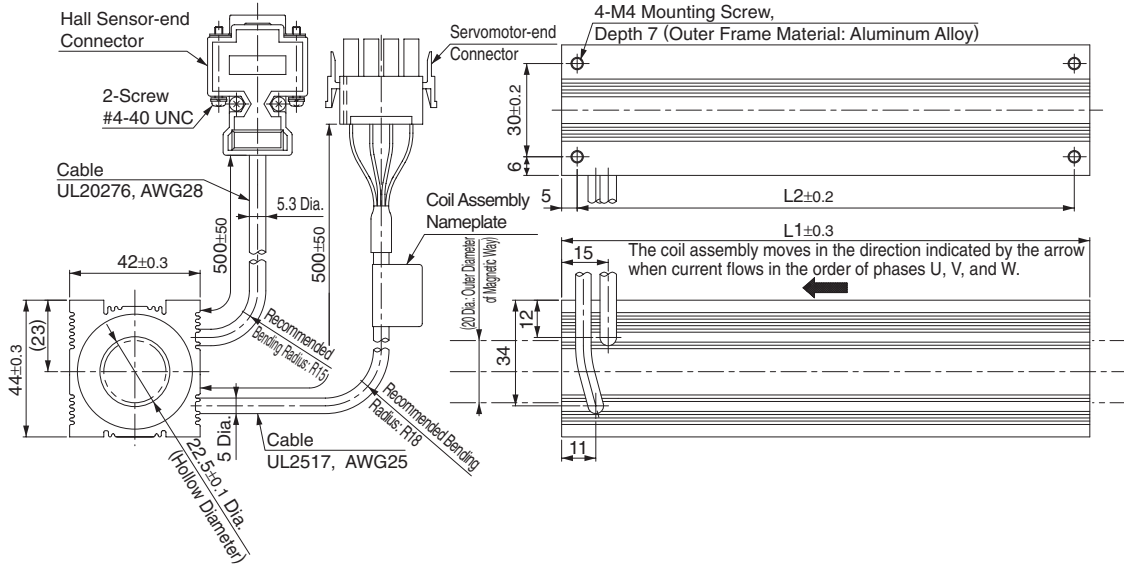

Hall Sensor Connector Specifications

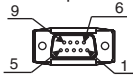

Pin Connector:
17JE-23090-02 (D8C)
by DDK Ltd.

The Mating Connector

Socket Connector:
17JE-13090-02 (D8C)
Stud: 17L-002C or
17L-002C1

Pin No.	Name
1	+5V (Power supply)
2	Phase U
3	Phase V
4	Phase W
5	0V (Power supply)
6	Not used
7	Not used
8	Not used
9	Not used

Linear Servomotor Connector Specifications

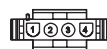

Plug: 350779-1
Pin : 350561-3 or
350690-3 (No.1 to 3)
770210-1 (No.4)

by Tyco
Electronics AMP K.K.
The Mating Connector

Cap: 350780-1
Socket: 350925-1 or
770673-1

Pin No.	Name	Wire Color
1	Phase U	Red
2	Phase V	White
3	Phase W	Blue
4	FG	Green

Hall Sensor Output Signals

When the coil assembly moves in the direction indicated by the arrow in the figure, the relationship between the hall sensor output signals S_u , S_v , S_w and the inverse power of each motor phase V_u , V_v , V_w becomes as shown in the figure below.

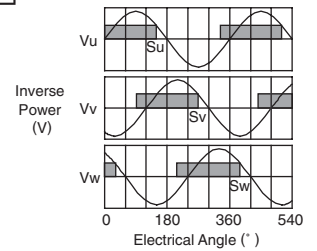

Coil Assembly Model SGLCW-	L1	L2	Approx. Mass* kg
D20A100AP	100	90	0.6
D20A135AP	135	125	0.8
D20A170AP	170	160	1.0

*: The values indicate the mass of coil assembly with a hall sensor unit.

External Dimensions Units: mm

(2) Magnetic Way: SGLCM-D20□□□A

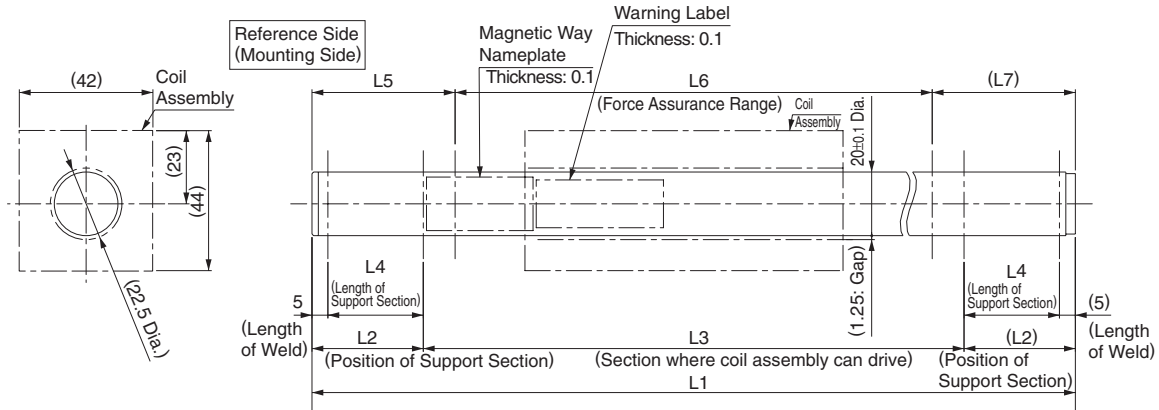

- Notes: 1 The magnetic way will become deformed if a magnetic attraction with the coil assembly is generated. Take measures over the entire driving range to prevent any interference between the magnetic way and the coil assembly after installation.
 2 The magnetic way may affect pacemakers. Keep a minimum distance of 200 mm from the magnetic way.

Magnetic Way Model SGLCM-	L1	L2	L3	L4	L5	L6	L7	Approx. Mass kg	Remarks
D20280A	280±1.6	35	210	30	45±0.3	190±1.2	45	0.68	Standard
D20315A	315±1.6	35	245	30	45±0.3	225±1.2	45	0.77	
D20350A	350±1.6	35	280	30	45±0.3	260±1.2	45	0.86	
D20385A	385±1.6	35	315	30	45±0.3	295±1.2	45	0.95	
D20420A	420±1.6	35	350	30	45±0.3	330±1.2	45	1.0	
D20455A	455±1.6	35	385	30	45±0.3	365±1.2	45	1.1	
D20490A	490±1.6	35	420	30	45±0.3	400±1.2	45	1.2	
D20555A	555±2.5	50	455	45	60±0.3	435±2.1	60	1.35	
D20590A	590±2.5	50	490	45	60±0.3	470±2.1	60	1.45	
D20625A	625±2.5	50	525	45	60±0.3	505±2.1	60	1.55	
D20660A	660±2.5	50	560	45	60±0.3	540±2.1	60	1.6	
D20695A	695±2.5	50	595	45	60±0.3	575±2.1	60	1.7	
D20730A	730±2.5	50	630	45	60±0.3	610±2.1	60	1.8	
D20765A	765±2.5	50	665	45	60±0.3	645±2.1	60	1.9	
D20800A	800±2.5	50	700	45	60±0.3	680±2.1	60	2.0	
D20835A	835±2.5	50	735	45	60±0.3	715±2.1	60	2.1	
D20870A	870±3	50	770	45	60±0.3	750±2.5	60	2.2	Standard

External Dimensions Units: mm

● SGLCW-D25

(1) Coil Assembly: SGLCW-D25A□□□AP

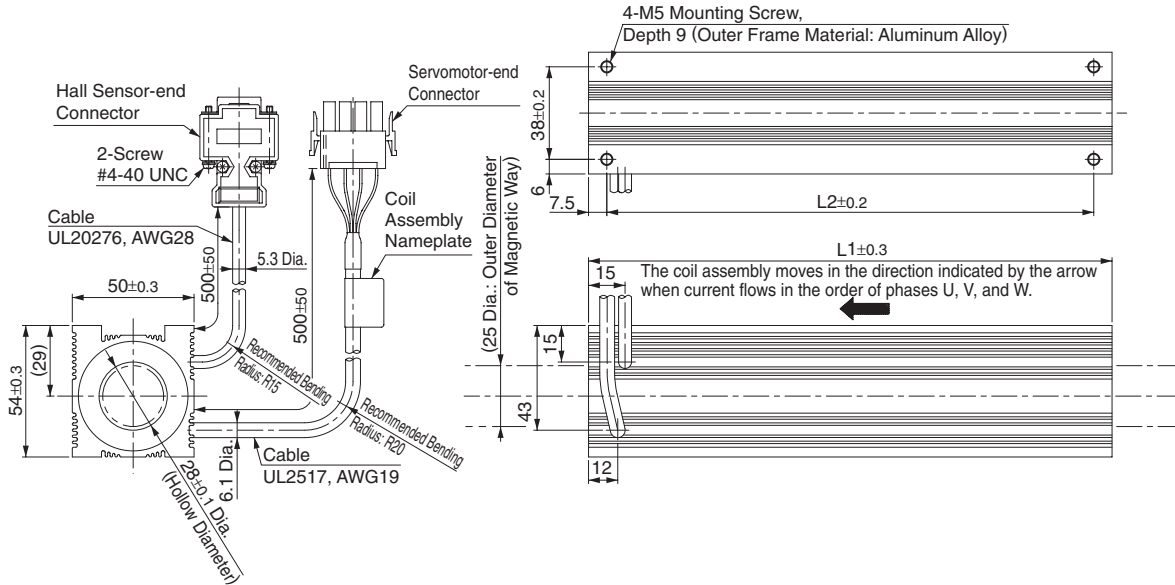

Hall Sensor Connector Specifications

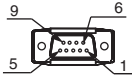

Pin Connector:
17JE-23090-02 (D8C)
by DDK Ltd.

The Mating Connector

Socket connector:
17JE-13090-02 (D8C)
Stud: 17L-002C or
17L-002C1

Pin No.	Name
1	+5V (Power supply)
2	Phase U
3	Phase V
4	Phase W
5	0V (Power supply)
6	Not used
7	Not used
8	Not used
9	Not used

Linear Servomotor Connector Specifications



Plug: 350779-1
Pin:
350561-3 or 350690-3
(No. 1 to 3)
350654-1 or 350669-1 (No. 4)
by Tyco Electronics AMP K.K.

The Mating Connector

Cap : 350780-1
Socket: 350925-1 or
770673-1

Pin No.	Name	Wire Color
1	Phase U	Red
2	Phase V	White
3	Phase W	Blue
4	FG	Green

Hall Sensor Output Signals

When the coil assembly moves in the direction indicated by the arrow in the figure, the relationship between the hall sensor output signals S_u , S_v , S_w and the inverse power of each motor phase V_u , V_v , V_w becomes as shown in the figure below.

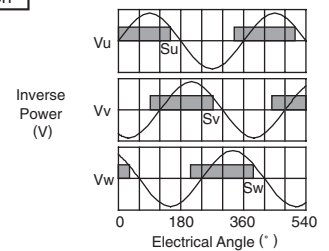

Coil Assembly Model SGLCW-	L1	L2	Approx. Mass* kg
D25A125AP	125	110	1.0
D25A170AP	170	153	1.4
D25A215AP	215	200	1.8

*: The values indicate the mass of coil assembly with a hall sensor unit.

External Dimensions Units: mm

(2) Magnetic Way: SGLCM-D25□□□A

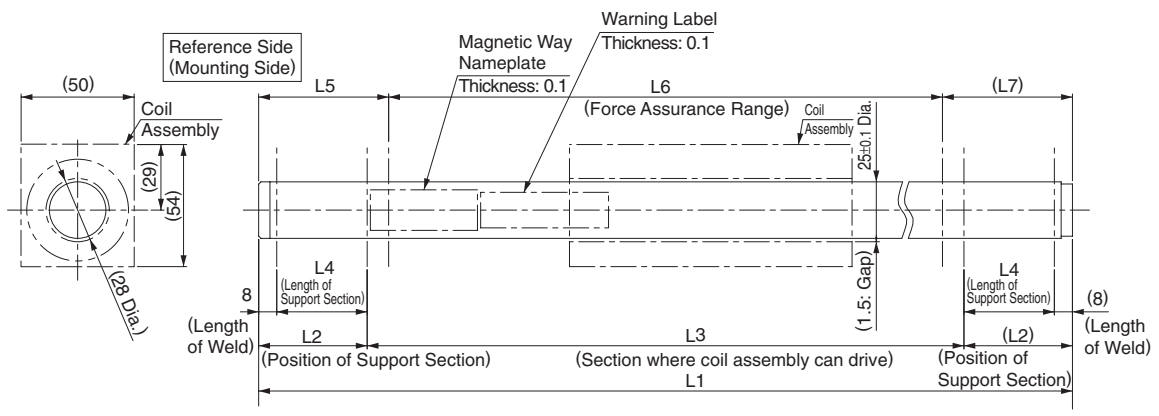

Notes: 1 The magnetic way will become deformed if a magnetic attraction with the coil assembly is generated. Take measures over the entire driving range to prevent any interference between the magnetic way and the coil assembly after installation.
 2 The magnetic way may affect pacemakers. Keep a minimum distance of 200 mm from the magnetic way.

Magnetic Way Model SGLCM-	L1	L2	L3	L4	L5	L6	L7	Approx. Mass kg	Remarks
D25360A	360±1.6	45	270	37	57.5±0.3	245±1.2	57.5	1.5	Standard
D25405A	405±1.6	45	315	37	57.5±0.3	290±1.2	57.5	1.65	
D25450A	450±1.6	45	360	37	57.5±0.3	335±1.2	57.5	1.8	
D25495A	495±1.6	45	405	37	57.5±0.3	380±1.2	57.5	1.95	
D25540A	540±1.6	45	450	37	57.5±0.3	425±1.2	57.5	2.1	
D25585A	585±1.6	45	495	37	57.5±0.3	470±1.2	57.5	2.25	
D25630A	630±1.6	45	540	37	57.5±0.3	515±1.2	57.5	2.4	
D25705A	705±2.5	60	585	52	72.5±0.3	560±2.1	72.5	2.85	
D25750A	750±2.5	60	630	52	72.5±0.3	605±2.1	72.5	3.0	
D25795A	795±2.5	60	675	52	72.5±0.3	650±2.1	72.5	3.15	
D25840A	840±2.5	60	720	52	72.5±0.3	695±2.1	72.5	3.3	Standard
D25885A	885±2.5	60	765	52	72.5±0.3	740±2.1	72.5	3.45	
D25930A	930±2.5	60	810	52	72.5±0.3	785±2.1	72.5	3.6	
D25975A	975±2.5	60	855	52	72.5±0.3	830±2.1	72.5	3.75	
D251020A	1020±2.5	60	900	52	72.5±0.3	875±2.1	72.5	3.9	
D251065A	1065±2.5	60	945	52	72.5±0.3	920±2.1	72.5	4.05	
D251110A	1110±3	60	990	52	72.5±0.3	965±2.5	72.5	4.2	

External Dimensions Units: mm

● SGLCW-D32

(1) Coil Assembly: SGLCW-D32A□□□AP

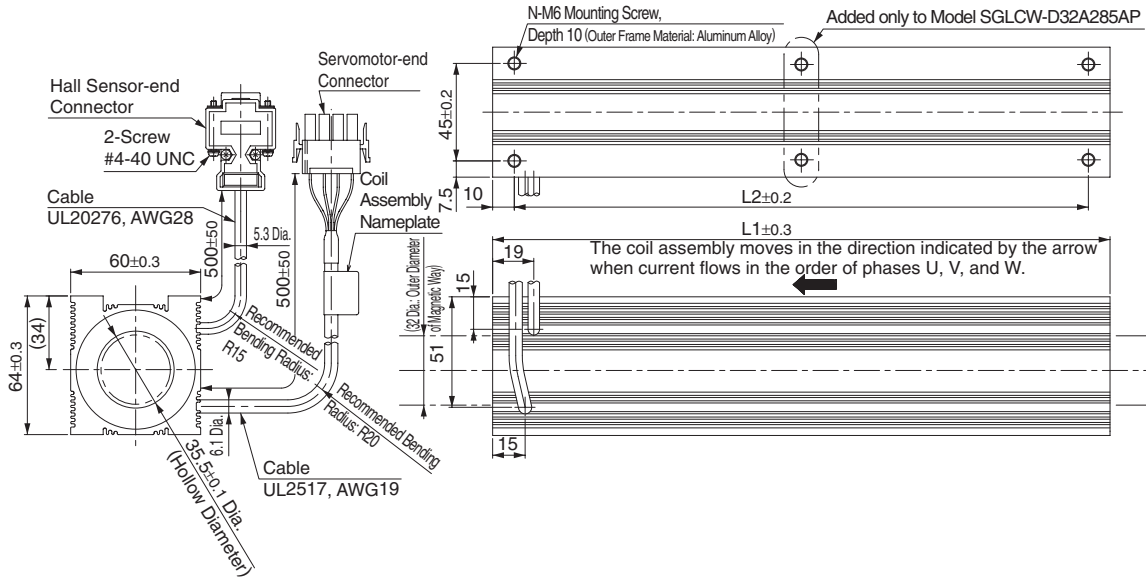

Hall Sensor Connector Specifications



Pin Connector:
17JE-23090-02 (D8C)
by DDK Ltd.

The Mating Connector

Socket connector:
17JE-13090-02 (D8C)
Stud: 17L-002C or
17L-002C1

Pin No.	Name
1	+5V (Power supply)
2	Phase U
3	Phase V
4	Phase W
5	0V (Power supply)
6	Not used
7	Not used
8	Not used
9	Not used

Linear Servomotor Connector Specifications

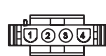

Plug: 350779-1
Pin:
350561-3 or 350690-3
(No. 1 to 3)
350654-1 or 350669-1 (No. 4)
by Tyco Electronics AMP K.K.

The Mating Connector

Cap: 350780-1
Socket: 350925-1 or
770673-1

Pin No.	Name	Wire Color
1	Phase U	Red
2	Phase V	White
3	Phase W	Blue
4	FG	Green

Hall Sensor Output Signals

When the coil assembly moves in the direction indicated by the arrow in the figure, the relationship between the hall sensor output signals S_u , S_v , S_w and the inverse power of each motor phase V_u , V_v , V_w becomes as shown in the figure below.

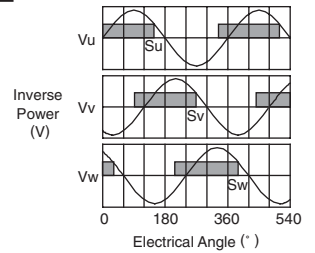

Coil Assembly Model SGLCW-	L1	L2	N	Approx. Mass* kg
D32A165AP	165	145	4	1.8
D32A225AP	225	205	4	2.5
D32A285AP	285	265	6	3.2

*: The values indicate the mass of coil assembly with a hall sensor unit.

External Dimensions Units: mm

(2) Magnetic Way: SGLCM-D32□□□A

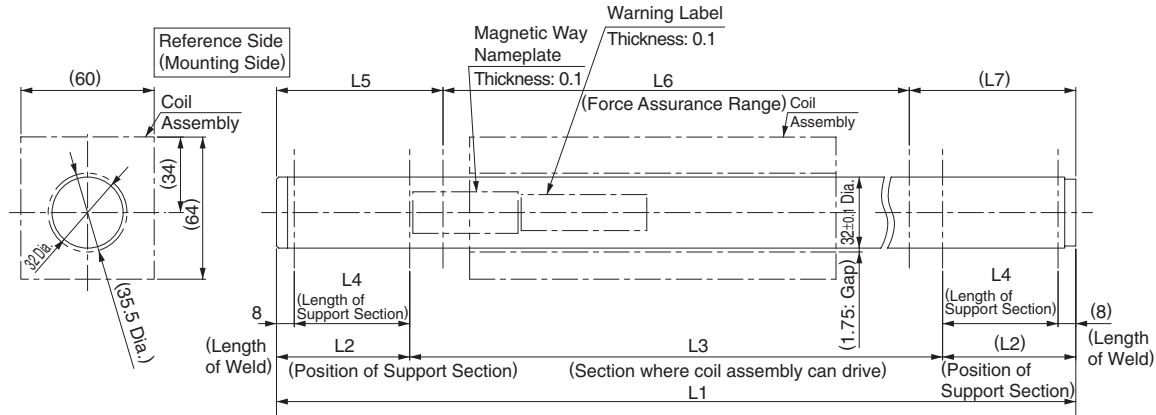

Notes: 1 The magnetic way will become deformed if a magnetic attraction with the coil assembly is generated.
 Take measures over the entire driving range to prevent any interference between the magnetic way and the coil assembly after installation.
 2 The magnetic way may affect pacemakers. Keep a minimum distance of 200 mm from the magnetic way.

Magnetic Way Model SGLCM-	L1	L2	L3	L4	L5	L6	L7	Approx. Mass kg	Remarks
D32480A	480±1.6	60	360	52	75±0.3	330±1.2	75	3.0	Standard
D32540A	540±1.6	60	420	52	75±0.3	390±1.2	75	3.4	
D32600A	600±1.6	60	480	52	75±0.3	450±1.2	75	3.8	
D32660A	660±1.6	60	540	52	75±0.3	510±1.2	75	4.2	
D32720A	720±1.6	60	600	52	75±0.3	570±1.2	75	4.6	
D32780A	780±1.6	60	660	52	75±0.3	630±1.2	75	5.0	
D32840A	840±1.6	60	720	52	75±0.3	690±1.2	75	5.4	
D32960A	960±2.5	90	780	82	105±0.3	750±2.1	105	5.9	
D321020A	1020±2.5	90	840	82	105±0.3	810±2.1	105	6.3	
D321080A	1080±2.5	90	900	82	105±0.3	870±2.1	105	6.7	
D321140A	1140±2.5	90	960	82	105±0.3	930±2.1	105	7.1	Standard
D321200A	1200±2.5	90	1020	82	105±0.3	990±2.1	105	7.5	
D321260A	1260±2.5	90	1080	82	105±0.3	1050±2.1	105	7.9	
D321320A	1320±2.5	90	1140	82	105±0.3	1110±2.1	105	8.3	
D321380A	1380±2.5	90	1200	82	105±0.3	1170±2.1	105	8.7	
D321440A	1440±2.5	90	1260	82	105±0.3	1230±2.1	105	9.1	
D321500A	1500±3	90	1320	82	105±0.3	1290±2.5	105	9.5	

Selecting Cables

●Cables Connections

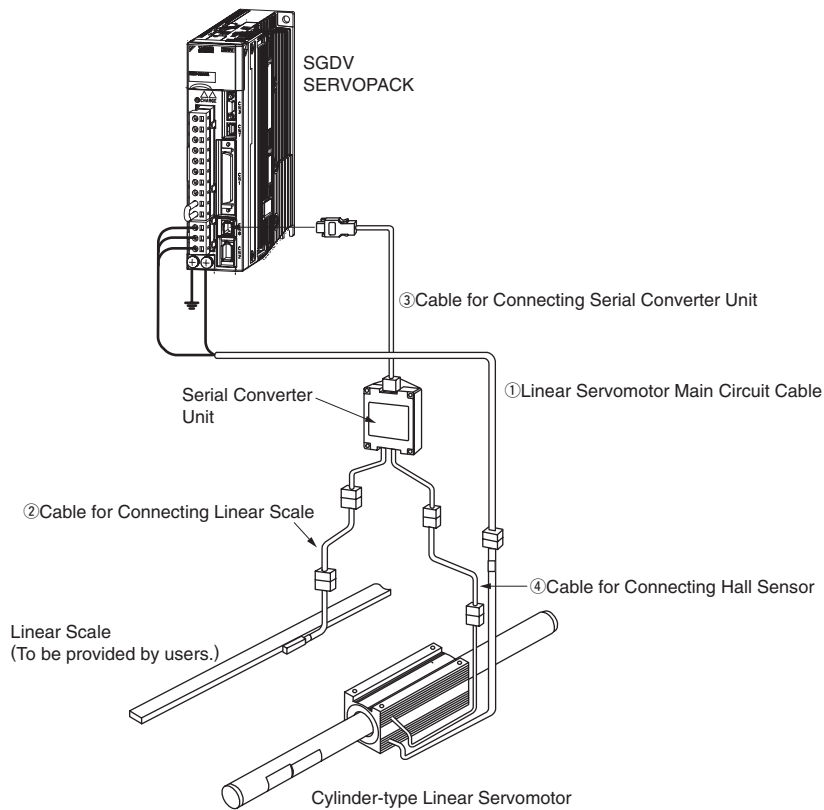

●Cables

Contact Yaskawa Controls Co., Ltd.

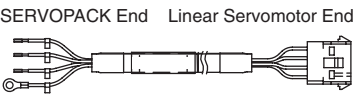
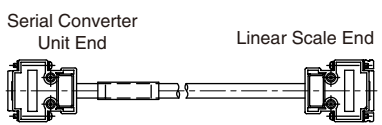
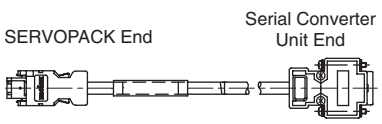
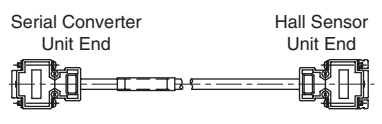
Name	Applicable Linear Servomotor Model	Length	Order No.	Specifications	Details
① Linear Servomotor Main Circuit Cables	All models	1 m	JZSP-CLN11-01-E	SERVOPACK End Linear Servomotor End 	(1)
		3 m	JZSP-CLN11-03-E		
		5 m	JZSP-CLN11-05-E		
		10 m	JZSP-CLN11-10-E		
		15 m	JZSP-CLN11-15-E		
② Cables for Connecting Linear Scales	All models	1 m	JZSP-CLL00-01-E	Serial Converter Unit End Linear Scale End 	(2)
		3 m	JZSP-CLL00-03-E		
		5 m	JZSP-CLL00-05-E		
		10 m	JZSP-CLL00-10-E		
		15 m	JZSP-CLL00-15-E		
③ Cables for Connecting Serial Converter Units	All models	1 m	JZSP-CLP70-01-E	SERVOPACK End Serial Converter Unit End 	(3)
		3 m	JZSP-CLP70-03-E		
		5 m	JZSP-CLP70-05-E		
		10 m	JZSP-CLP70-10-E		
		15 m	JZSP-CLP70-15-E		
④ Cables for Connecting Hall Sensors	All models	1 m	JZSP-CLL10-01-E	Serial Converter Unit End Hall Sensor Unit End 	(4)
		3 m	JZSP-CLL10-03-E		
		5 m	JZSP-CLL10-05-E		
		10 m	JZSP-CLL10-10-E		
		15 m	JZSP-CLL10-15-E		

Selecting Cables Units: mm

(1) Linear Servomotor Main Circuit Cables:
JZSP-CLN11-□□-E

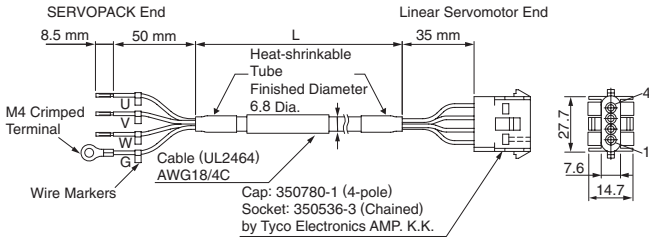

• Wiring Specifications

SERVOPACK-end Leads		Linear Servomotor-end Connector	
Wire Color	Signal	Signal	Pin. No.
Red	Phase U	Phase U	1
White	Phase V	Phase V	2
Blue	Phase W	Phase W	3
Green/yellow	FG	FG	4

(2) Cables for Connecting Linear Scales:
JZSP-CLL00-□□-E

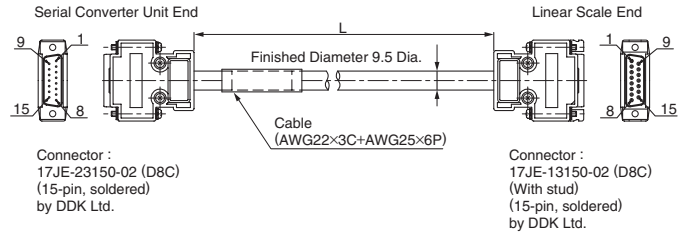

• Wiring Specifications

Serial Converter Unit End		Linear Scale End	
Pin No.	Signal	Pin No.	Signal
1	/Cos(V1-)	1	/Cos(V1-)
2	/Sin(V2-)	2	/Sin(V2-)
3	Ref(V0+)	3	Ref(V0+)
4	+5V	4	+5V
5	5Vs	5	5Vs
6	BID	6	BID
7	Vx	7	Vx
8	Vq	8	Vq
9	Cos(V1+)	9	Cos(V1+)
10	Sin(V2+)	10	Sin(V2+)
11	/Ref(V0+)	11	/Ref(V0-)
12	0V	12	0V
13	0Vs	13	0Vs
14	DIR	14	DIR
15	Inner	15	Inner
Case	Shield	Case	Shield

(3) Cables for Connecting Serial Converter Units:
JZSP-CLP70-□□-E

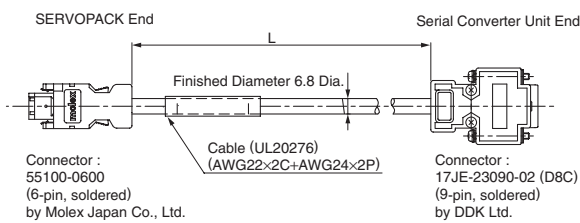

• Wiring Specifications

SERVOPACK End			Serial Converter Unit End		
Pin No.	Signal	Wire Color	Pin No.	Signal	Wire Color
1	PG5V	Red	1	+5V	Red
2	PG0V	Black	5	0V	Black
3	-	-	3	-	-
4	-	-	4	-	-
5	PS	Light blue	2	Phase S output	Light blue
6	/PS	Light blue/white	6	Phase /S output	Light blue/white
Shell	Shield	-	Case	Shield	-
			7	-	-
			8	-	-
			9	-	-

(4) Cables for Connecting Hall Sensors:
JZSP-CLL10-□□-E

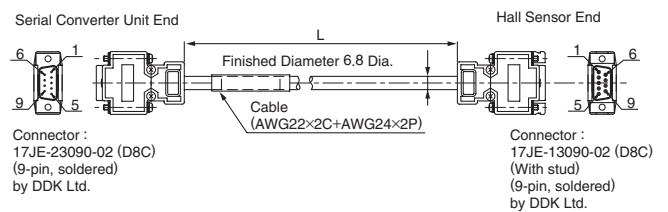

• Wiring Specifications

Serial Converter Unit End		Hall Sensor End	
Pin No.	Signal	Pin No.	Signal
1	+5V	1	+5V
2	Phase U input	2	Phase U input
3	Phase V input	3	Phase V input
4	Phase W input	4	Phase W input
5	0V	5	0V
6	-	6	-
7	-	7	-
8	-	8	-
9	-	9	-
Case	Shield	Case	Shield



Linear Servomotor General Instructions

Serial Converter Unit (Model: JZDP-D00□-□□□-E)

● Characteristics and Specifications

Items		Specifications
Electrical Characteristics	Power Supply Voltage	+5.0V±5%, ripple content 5% max.
	Current Consumption*1	120 mA Typ. 350 mA max.
	Signal Resolution	Input two-phase sine wave: 1/256 pitch
	Max. Response Frequency	250 kHz
	Analog Input Signals*2 (cos, sin, Ref)	Differential input amplitude: 0.4 to 1.2 V Input signal level: 1.5 to 3.5 V
	Hall Sensor Input Signal	CMOS level
	Output Signals*3	Position data, hall sensor information, and alarms
	Output Method	Serial data transmission [HDLC (High-level Data Link Control) protocol format with Manchester codes]
	Transmission Cycle	62.5 μs
	Output Circuit	Balanced transceiver (SN75LBC176 or the equivalent) Internal terminal resistance: 120 Ω
Mechanical Characteristics	Approx. Mass	150 g
	Vibration Resistance	98 m/s ² max. (10 to 2500 Hz) in three directions
	Impact Resistance	980 m/s ² , (11 ms) two times in three directions
Environmental Conditions	Operating Temperature	0 to 55°C
	Storage Temperature	-20 to +80°C
	Humidity	20% to 90% RH (no condensation)

*1: The current consumption of the linear scale and hall sensor is not included in this value.

The current consumption of linear scale and hall sensor must be taken into consideration for the current capacity of host controller that supplies the power. The current consumption of hall sensor: Approx. 40 mA.

*2: Input a value within the specified range. Otherwise, incorrect position information is output, and the device may be damaged.

*3: The power is turned on, and the transmission is enabled after 100 ms to 300 ms.

● Model Designations

JZDP - D003 - 001 - E

Serial Converter Unit Model			
Code	Appearance	Applicable Linear Scale	Hall Sensor
D003		Manufactured by HEIDENHAIN	None
D005		Manufactured by RENISHAW	None
D006		Manufactured by HEIDENHAIN	Provided
D008		Manufactured by RENISHAW	Provided

Applicable Linear Servomotor					
Servomotor Model		Code	Servomotor Model		Code
SGLGW- (Standard Type)	30A050C	250	SGLTW-	20A170A	011
	30A080C	251		35A170A	014
	40A140C	252		35A170H	105
	40A253C	253		50A170 H	108
	40A365C	254	SGLCW-	D16A085AP	354
	60A140C	258		D16A115AP	373
	60A253C	259		D16A145AP	356
60A365C	260	D20A100AP		357	
SGLGW- (High-force Type)	40A140C	255		D20A135AP	358
	40A253C	256		D20A170AP	359
	40A365C	257	D25A125AP	360	
	60A140C	261	D25A170AP	374	
SGLFW-	60A253C	262	D25A215AP	362	
	20A090A	017	D32A165AP	363	
	20A120A	018	D32A225AP	364	
	35A120A	019	D32A285AP	365	
	35A230A	020			
	50A200B	181			

Serial Converter Unit (Model: JZDP-D00□-□□□-E)

● Analog Signal Input Timing

The following figure shows the input timing of the analog signals.

When the cos and sin signals are shifted 180 degrees, the differential signals are the /cos and /sin signals.

The specifications of the cos, /cos, sin, and /sin signals are identical except for the phase.

Input the signals Ref and /Ref so that they shall cross each other as shown in the figure because they are input into the converter. When they are crossed, the output data will be counted up.

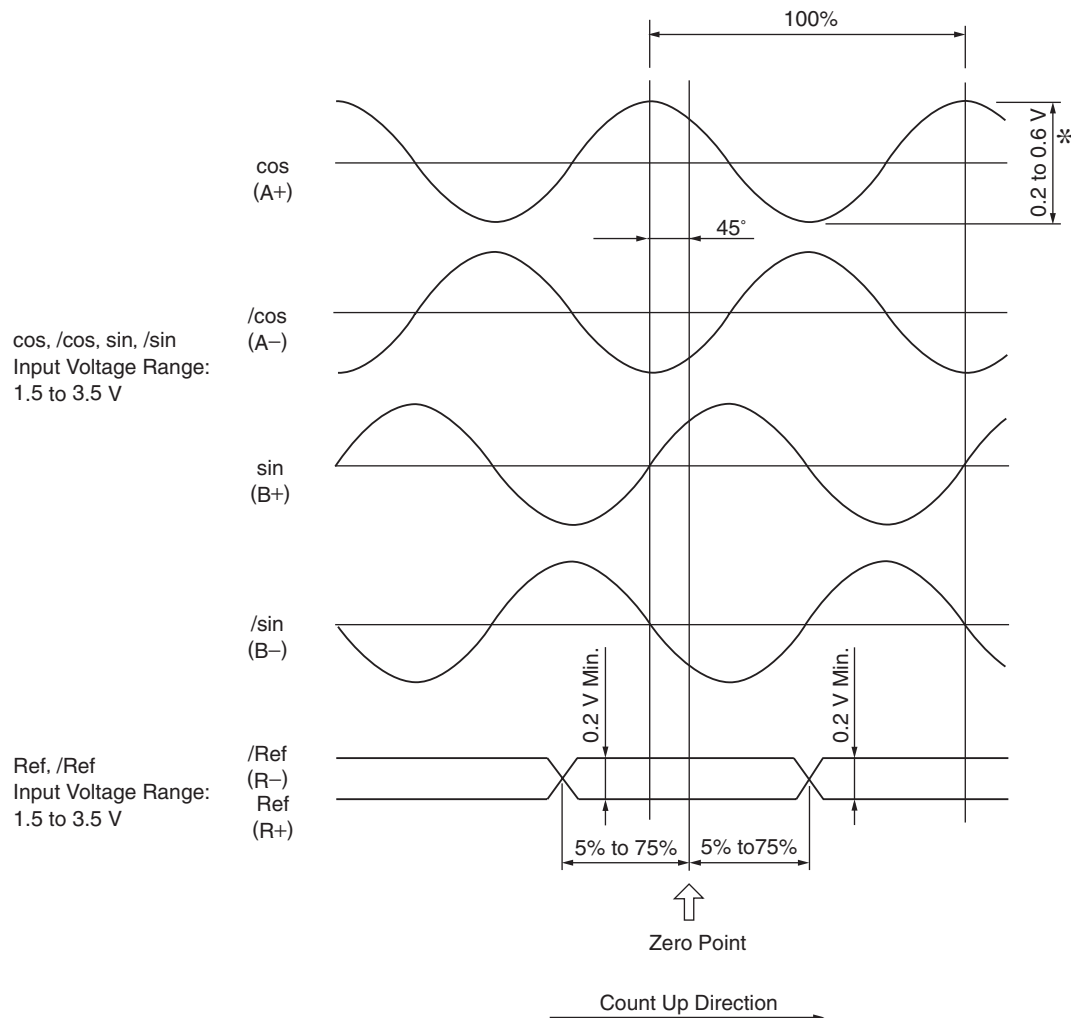

*:If the analog signal amplitude declines to about 0.35 V because of differential amplitude, the serial converter outputs an alarm.

IMPORTANT

■ Precautions

- 1 Never perform insulation resistance and withstand voltage tests.
- 2 When analog signals are input to the serial converter unit, noise influence on the analog signals affects the unit's ability to output correct position information. The analog cable must be as short as possible and shielded.
- 3 Use the serial converter unit without gases such as H₂S.
- 4 Do not connect or disconnect the unit while power is being supplied, or the unit may be damaged.
- 5 When using multiple axes, use a shield cable for each axis. Do not use a shield cable for multiple axes.

Serial Converter Unit (Model: JZDP-D00□-□□□-E) Units: mm

● Without Cable for Hall Sensor (For Linear Scale by HEIDENHAIN Corporation)

Serial Converter Unit Model: JZDP-D003-□□□-E

(1) Connection Example

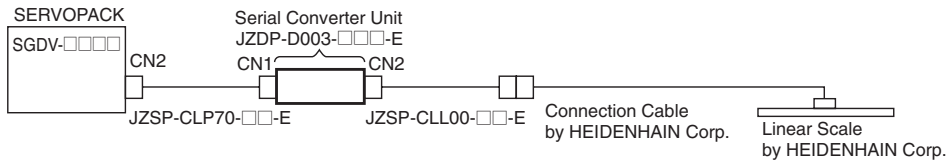

(2) External Dimensions

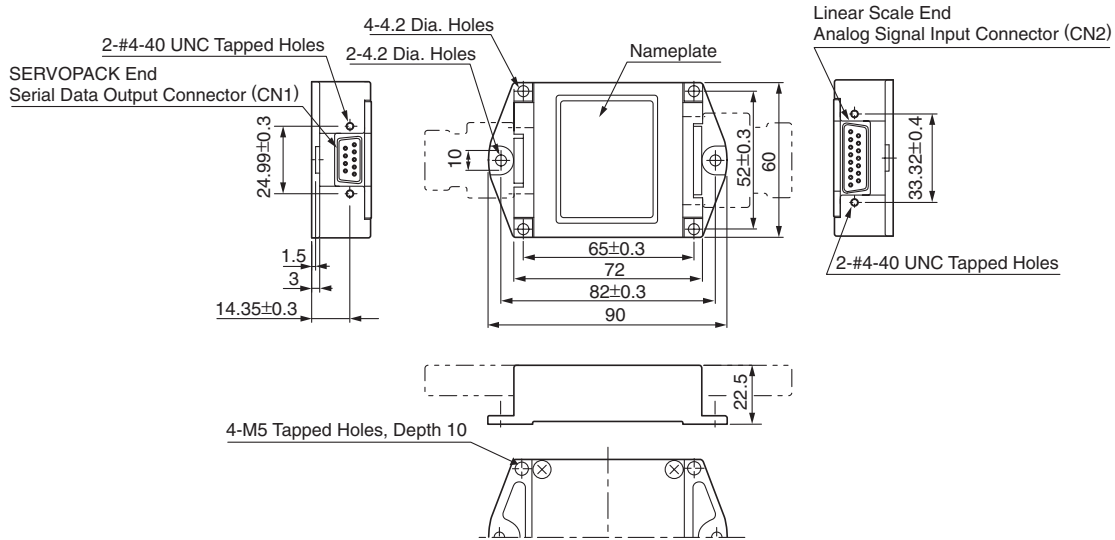

Pin No.	Signal
1	+5V
2	Phase S output
3	Not used
4	Not used
5	0V
6	Phase /S output
7	Not used
8	Not used
9	Not used
Case	Shield

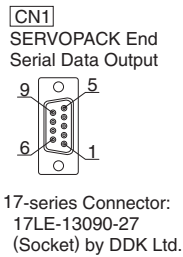

Pin No.	Signal
1	cos input (A+)
2	0V
3	sin input (B+)
4	+5V
5	Not used
6	Not used
7	/Ref input (R-)
8	Not used
9	/cos input (A-)
10	0V sensor
11	/sin input (B-)
12	5V sensor
13	Not used
14	Ref input (R+)
15	Not used
Case	Shield

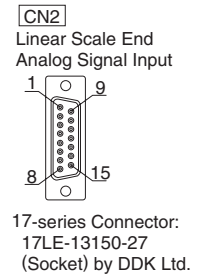

- Notes:
- 1 Do not use the unused pins.
 - 2 Contact HEIDENHAIN Corporation for details of connection cables (analog 1 Vp-p output, D-sub 15-pin, male) by HEIDENHAIN Corporation.
 - 3 Use the same terminal for 5-V sensor and phase-W input.
 - 4 Phase U, V, and W input are internally pulled up at 10 kΩ.

Serial Converter Unit (Model: JZDP-D00□-□□□-E) Units: mm

● Without Cable for Hall Sensor (For Linear Scale by Renishaw plc.)

Serial Converter Unit Model: JZDP-D005-□□□-E

(1) Connection Example

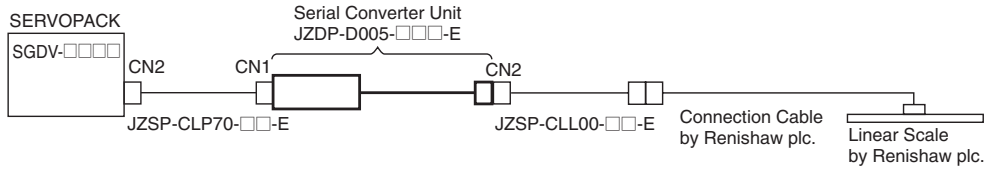

(2) External Dimensions

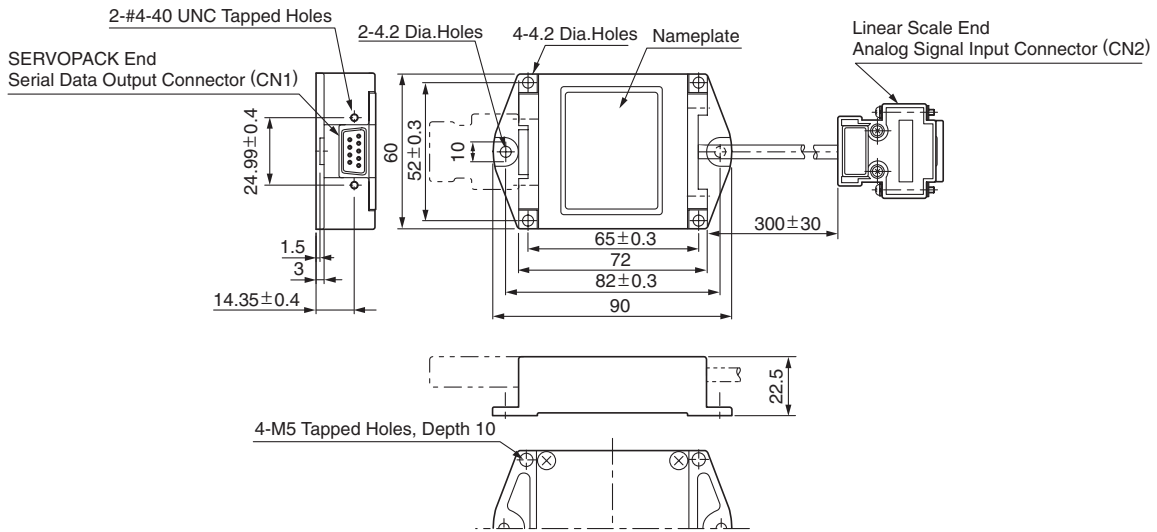

Pin No.	Signal
1	+5V
2	Phase S output
3	Not used
4	Not used
5	0V
6	Phase /S output
7	Not used
8	Not used
9	Not used
Case	Shield

SERVOPACK does not have the function to process Vq signals.

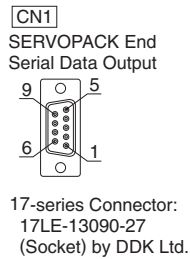

Pin No.	Signal
1	cos input (V1-)
2	sin input (V2-)
3	Ref input (V0+)
4	+5V
5	5Vs
6	Not used
7	Not used
8	Not used
9	cos input (V1+)
10	sin input (V2+)
11	/Ref input (V0-)
12	0V
13	0Vs
14	Not used
15	inner (0V)
Case	Shield

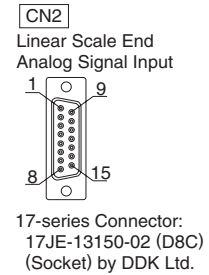

- Notes: 1 Do not use the unused pins.
 2 Contact Renishaw plc. for details of connection cables (analog 1 Vp-p output, D-sub 15-pin, male) by Renishaw plc. However, the BID and DIR signals are not connected.
 3 Use the linear scale-end connector to change the zero point specifications of the linear scale.

Serial Converter Unit (Model: JZDP-D00□-□□□-E) Units: mm

● With Cable for Hall Sensor (For Linear Scale by HEIDENHAIN Corporation)

Serial Converter Unit Model: JZDP-D006-□□□-E

(1) Connection Example

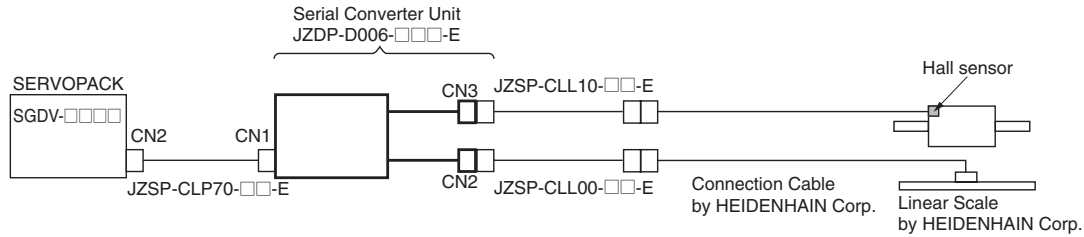

(2) External Dimensions

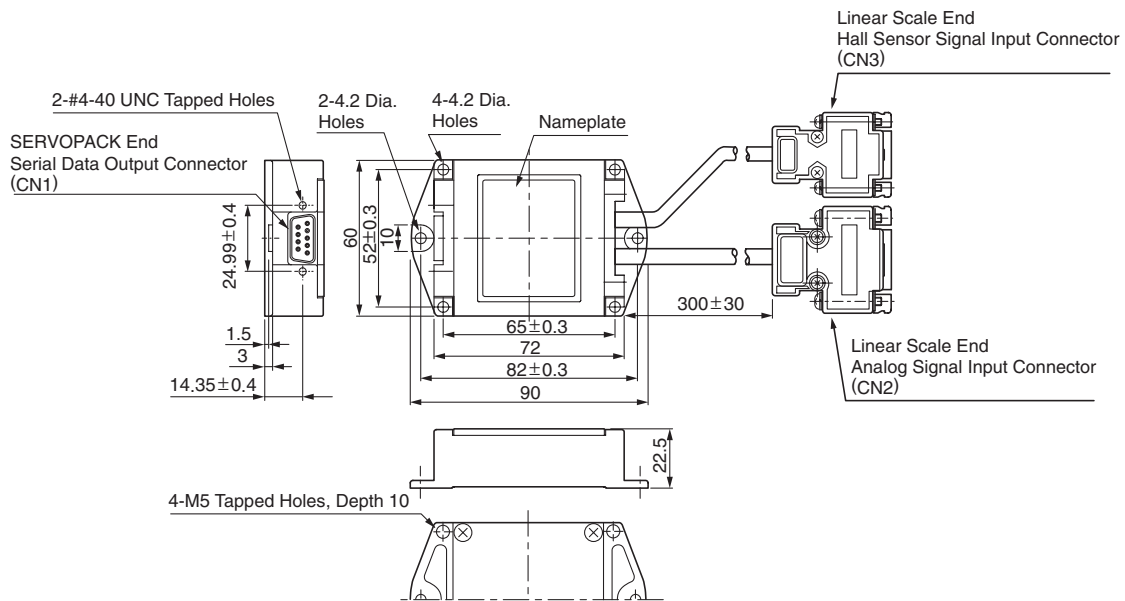

CN1
SERVOPACK End
Serial Data Output

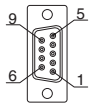

17-series Connector:
17JE-13090-27
(Socket) by DDK Ltd.

CN2
Linear Scale End
Analog Signal Input

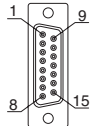

17-series Connector:
17JE-13150-02 (D8C)
(Socket) by DDK Ltd.

CN3
Linear Scale End
Hall Sensor Signal Input

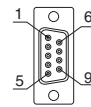

17-series Connector:
17JE-13090
by DDK Ltd.

Pin No.	Signal
1	+5V
2	Phase S output
3	Not used
4	Not used
5	0V
6	Phase /S output
7	Not used
8	Not used
9	Not used
Case	Shield

Pin No.	Signal
1	cos input (A+)
2	0V
3	sin input (B+)
4	+5V
5	Not used
6	Not used
7	/Ref input (R-)
8	Not used
9	/cos input (A-)
10	0V sensor
11	/sin input (B-)
12	5V sensor
13	Not used
14	Ref input (R+)
15	Not used
Case	Shield

Pin No.	Signal
1	+5V
2	Phase U input
3	Phase V input
4	Phase W input
5	0V
6	Not used
7	Not used
8	Not used
9	Not used
Case	Shield

Notes: 1 Do not use the unused pins.

2 Contact HEIDENHAIN Corporation for details of connection cables (analog 1 Vp-p output, D-sub 15-pin, male) by HEIDENHAIN Corporation.

3 Phase U, V, and W input are internally pulled up at 10 kΩ.

Serial Converter Unit (Model: JZDP-D00□-□□□-E) Units: mm

● With Cable for Hall Sensor (For Linear Scale by Renishaw plc.)

Serial Converter Unit Model: JZDP-D008-□□□-E

(1) Connection Example

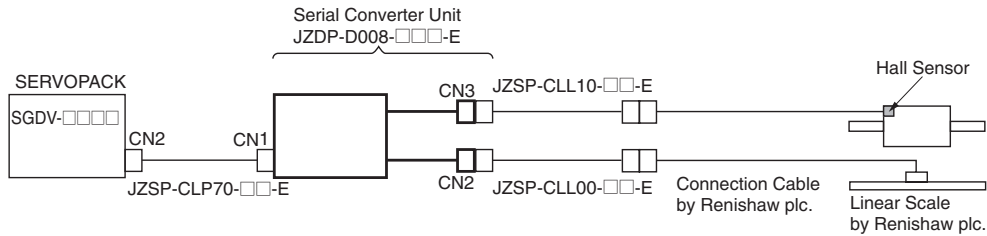

(2) External Dimensions

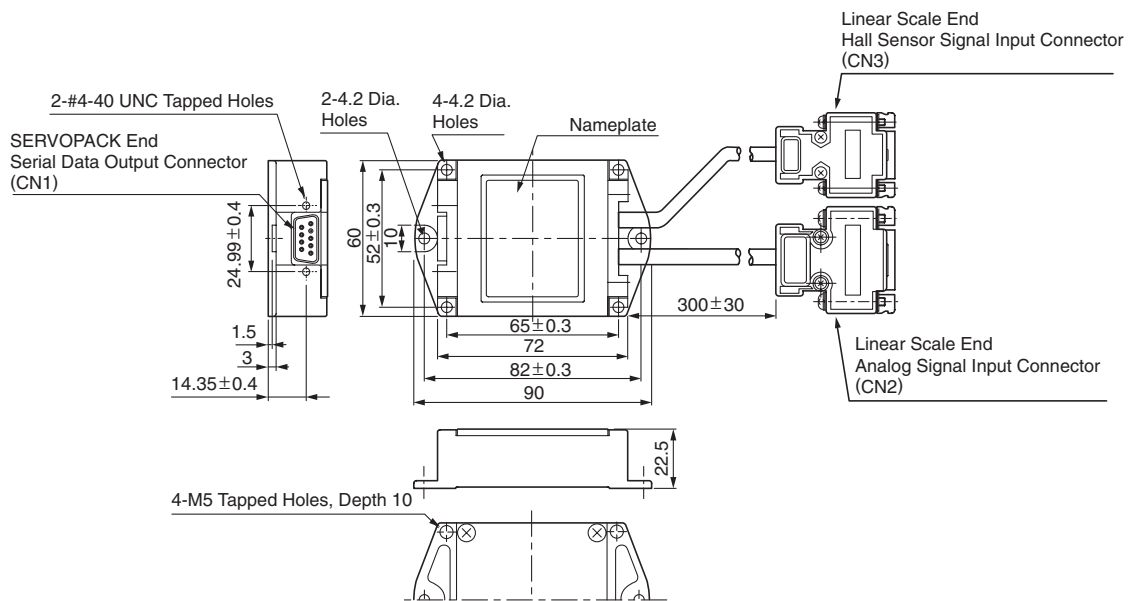

CN1
SERVOPACK End
Serial Data Output

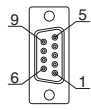

17-series Connector:
17JE-13090-27
(Socket) by DDK Ltd.

CN2
Linear Scale End
Analog Signal Input

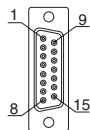

17-series Connector:
17JE-13150-02 (D8C)
(Socket) by DDK Ltd.

CN3
Linear Scale End
Hall Sensor Signal Input

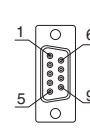

17-series Connector:
17JE-13090
by DDK Ltd.

Pin No.	Signal
1	+5V
2	Phase S output
3	Not used
4	Not used
5	0V
6	Phase /S output
7	Not used
8	Not used
9	Not used
Case	Shield

Pin No.	Signal
1	/cos input (V1-)
2	/sin input (V2-)
3	Ref input (V0+)
4	+5V
5	5Vs
6	Not used
7	Not used
8	Not used
9	cos input (V1+)
10	sin input (V2+)
11	/Ref input (V0-)
12	0 V
13	0 Vs
14	Not used
15	Inner
Case	Shield

Pin No.	Signal
1	+5V
2	Phase U input
3	Phase V input
4	Phase W input
5	0V
6	Not used
7	Not used
8	Not used
9	Not used
Case	Shield

- Notes: 1 Do not use the unused pins.
 2 Contact Renishaw plc. for details of connection cables (analog 1 Vp-p output, D-sub 15-pin, male) by Renishaw plc. However, the BID and DIR signals are not connected.
 3 Use the linear scale-end connector to change the zero point specifications of the linear scale.
 4 Phase U, V, and W input are internally pulled up at 10 kΩ.

Flexible Cables

●Life of Flexible Cable

The flexible cable supports 10,000,000 or more operations of bending life with the recommended bending radius R. The following table shows the recommended bending radius R of each cable.

Cable Type	Model	Recommended Bending Radius mm
Linear Servomotor Main Circuit Cables	JZSP-CLN11-□□-E	35
	JZSP-CLN21-□□-E	38
	JZSP-CLN39-□□-E	50
	JZSP-CLN14-□□-E	35
Cables for Connecting Linear Scales	JZSP-CLL00-□□-E	57
Cables for Connecting Hall Sensors	JZSP-CLL10-□□-E	60
Cables for Connecting Serial Converter Units	JZSP-CLP70-□□-E	46

●Conditions

- 1 Repeat moving one end of the cable forward and backward for 320 mm with using the test equipment shown in the following figure.
- 2 Connect the lead wires in parallel, and count the number of cable return motion times until a lead wire is disconnected. Note that one reciprocating is counted as one test.

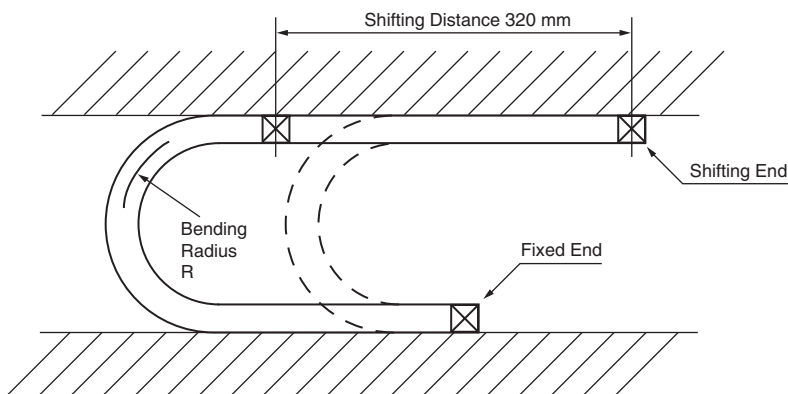

- Notes: 1 The life of flexible cable differs largely depending on the amount of mechanical shocks, mounting to the cable, and fixing methods. The life of flexible cable is limited under the specified conditions.
- 2 The life of flexible cable indicates the number of bending times in which lead wires are electrically conducted and by which no cracks and damages that affects the performance of cable sheathing are caused. Disconnecting the shield wire is not taken into account.

Flexible Cables

● Wiring Precautions

Even if the recommended bending radius R is respected in the mechanical design, incorrect wiring may cause early disconnection. Observe the following precautions when wiring.

(1) Cable twisting

Straighten the flexible cables before wiring.

Twisted cables cause early disconnection. Check the indication on the cable surface to make sure that the cable is not twisted.

(2) Fixing method

Do not fix the moving points of the flexible cable. Stress on the fixed points may cause early disconnection. Fix the cable at the minimum number of points.

(3) Cable length

If the cable length is too long, it may cause the cable's sagging. Besides the cable length is too short, it may cause the excessive tension on the fixed points that will cause early disconnection. Use a flexible cable with the optimum length.

(4) Interference between cables

Avoid interference between cables.

Interference limits the motion of flexible cable, which causes early disconnection. Keep enough distance between cables, or provide a partition when wiring.

Linear Sliders

Σ -Trac

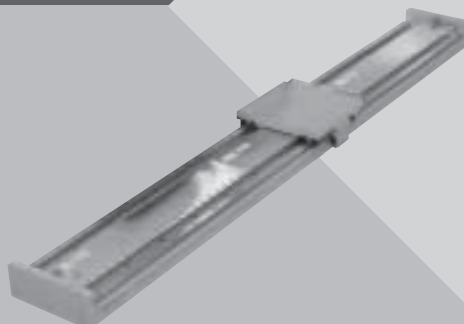

Model Designations

SGT 1 F3 1 - 030 A H 20 - 0

Σ -Trac Series
Linear Slider

Linear Slider Type
1 : Standard
(Aluminum base)
2 : High-rigidity
(Steel or iron base)

Mounted Linear
Servomotor

Moving Coil Model	Code
SGLFW-35A120A	F3
SGLFW-35A230A	F4
SGLFW-50A200B	F9
SGLGW-40A140C	GD
SGLGW-40A253C	GE
SGLGW-40A365C	GF
SGLGW-60A140C	GG
SGLGW-60A253C	GH
SGLGW-60A365C	GI

Number of Tables (per Axis)
1 : 1 table
2 : 2 tables
to
n : n tables

Surface Treatment

0 : Aluminum base; Clear anodized aluminum coating
Steel or iron base; Black paint
1 : Aluminum base; Black anodized aluminum coating
Steel or iron base; Electroless nickel plating or Raydent® processing

Linear Scale Resolution

20 : 20 μ m
04 : 4 μ m

Linear Scale Manufacturer

H : HEIDENHAIN Corporation
R : Renishaw plc.

Linear Scale Output Form

A : Analog output 1 Vp-p

Stroke Length

007 : 70 mm
to
200 : 2000 mm

Features

- For long strokes and high-speed, high-accuracy positioning (repetitive positioning accuracy less than $\pm 1.0 \mu\text{m}$).
- Several tables can be mounted on one magnetic way, and each table can be driven independently.
- Standard and high-precision models are available.

Model Classification

● Force

SERVOPACK Model SGD V- Three-phase 200 VAC	Σ -Trac Series Linear Sliders Model	Force							
		200 N	400 N	600 N	800 N	1000 N	1200 N	Continuous force	Peak force
1R6	SGT□F3□-□□□	[Bar chart showing force capacity]							
3R8	SGT□F4□-□□□	[Bar chart showing force capacity]							
5R5	SGT□F9□-□□□	[Bar chart showing force capacity]							
R90	SGT□GD□-□□□	[Bar chart showing force capacity]							
1R6	SGT□GE□-□□□	[Bar chart showing force capacity]							
2R8	SGT□GF□-□□□	[Bar chart showing force capacity]							
1R6	SGT□GG□-□□□	[Bar chart showing force capacity]							
2R8	SGT□GH□-□□□	[Bar chart showing force capacity]							
5A5	SGT□GI□-□□□	[Bar chart showing force capacity]							

● Stroke Length

Model	Stroke Length	500 mm	1000 mm	1500 mm	2000 mm	
SGT□F3□-□□□	80 mm	[Bar chart showing stroke length]				1950 mm
SGT□F4□-□□□	180 mm	[Bar chart showing stroke length]				1830 mm
SGT□F9□-□□□	70 mm	[Bar chart showing stroke length]				1830 mm
SGT□GD□-□□□	90 mm	[Bar chart showing stroke length]				1300 mm
SGT□GE□-□□□	120 mm	[Bar chart showing stroke length]				1200 mm
SGT□GF□-□□□	140 mm	[Bar chart showing stroke length]				1080 mm
SGT□GG□-□□□	90 mm	[Bar chart showing stroke length]				1300 mm
SGT□GH□-□□□	120 mm	[Bar chart showing stroke length]				1200 mm
SGT□GI□-□□□	140 mm	[Bar chart showing stroke length]				1080 mm

Contact your Yaskawa representative for information on strokes other than those listed.

SGT1F3□ and SGT1F4□ Linear Sliders

● Ratings and Specifications

Time Rating: Continuous
 Insulation Resistance: 500 VDC, 10 MΩ min.
 Ambient Temperature: 0 to 40°C
 Excitation: Permanent magnet

Withstand Voltage: 1500 VAC for one minute
 Enclosure: Self-cooled
 Ambient Humidity: 20% to 80% (no condensation)
 Allowable Winding Temperature: 130°C
 (Thermal class B)

Linear Slider Model*1		SGT1F3□-□□□AH20-0	SGT1F4□-□□□AH20-0
Mounted Linear Servomotor Model	SGLFW-	35A120AP	35A230AP
Applicable SERVOPACK Model	SGDV-	1R6	3R8
Applicable Serial Converter Unit Model	JZDP-	D006-019	D006-020
Rated Force	N	80	160
Peak Force	N	220	440
Force Constant	N / Arms	62.4	62.4
Motor Constant	N / \sqrt{W}	14.4	20.4
Maximum Payload*2*3	kg	30	70
Movable Member Mass	kg	3.1	5.3
Total Mass	kg	See Table 1	See Table 2
Effective Stroke	mm	on the next page.	on the next page.
Resolution	μm	0.078 (20μm / 256)	
Repeatability*4	μm	±1.0	±1.0

*1: Squares (□□□) are used to indicate the stroke length code shown in Tables 1 and 2.
 *2: Values obtained when the acceleration is 4.9 m/s².
 *3: Contact your Yaskawa representative if the expected payload exceeds the value indicated in the table.
 *4: Values obtained when the ambient temperature is constant.

● Performance Curves

● Force - Speed

(A) : Continuous Duty Zone (B) : Intermittent Duty Zone

(1) SGT1F3□

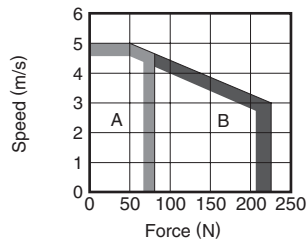

(2) SGT1F4□

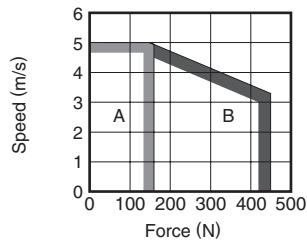

● Effective Force - Ambient Temperature

● Load Mass - Acceleration

When the sensor temperature is 50°C or less
 Average speed (m/s) : 0 — 1 — 2 —
 Note: Average speed = Total movement distance (m) / cycle time (s)

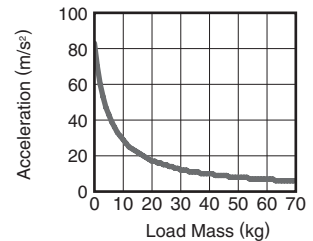
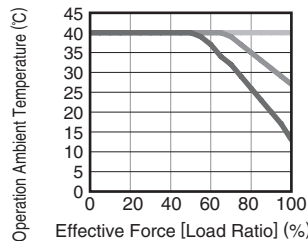
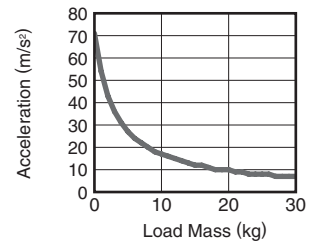
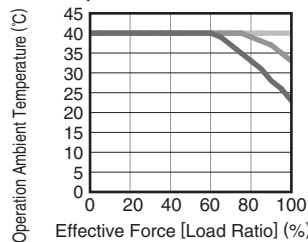

SGT1F3 and SGT1F4 Linear Sliders Units: mm

● External Dimensions

(1) SGT1F31

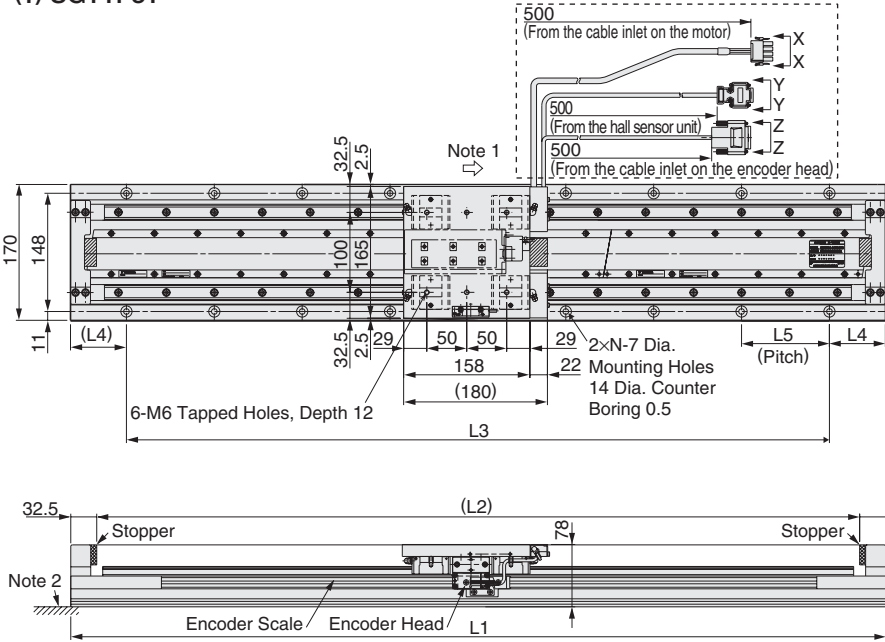

Table 1

Stroke Code	Length	L1 mm	L2 mm	L3 mm	L4 mm	L5 mm	N	Total Mass kg
008	80	360	295	270	45	90	4	9.1
030	300	580	515	440			5	13.0
041	410	690	625	550			6	14.9
052	520	800	735	660			7	16.8
063	630	910	845	770			8	18.6
074	740	1020	955	880			9	20.5
085	850	1130	1065	990			10	22.5
096	960	1240	1175	1100			11	24.5
107	1070	1350	1285	1210	70	110	12	26.3
118	1180	1460	1395	1320			13	28.3
129	1290	1570	1505	1430			14	30.1
140	1400	1680	1615	1540			15	32.0
151	1510	1790	1725	1650			16	34.0
162	1620	1900	1835	1760			17	35.9
173	1730	2010	1945	1870			18	37.8
184	1840	2120	2055	1980			19	39.7
195	1950	2230	2165	2090			20	41.5

(2) SGT1F41

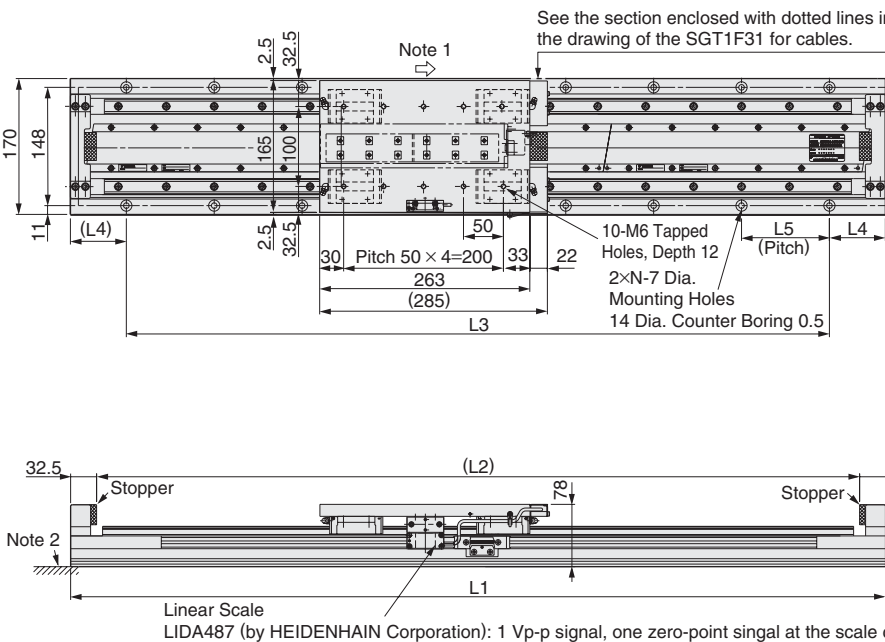

Table 2

Stroke Code	Length	L1 mm	L2 mm	L3 mm	L4 mm	L5 mm	N	Total Mass kg
018	180	580	515	440			5	15.1
029	290	690	625	550			6	17.0
040	400	800	735	660			7	18.9
051	510	910	845	770			8	20.7
062	620	1020	955	880			9	22.7
073	730	1130	1065	990			10	24.6
084	840	1240	1175	1100			11	27.1
095	950	1350	1285	1210	70	110	12	28.5
106	1060	1460	1395	1320			13	30.4
117	1170	1570	1505	1430			14	32.2
128	1280	1680	1615	1540			15	34.2
139	1390	1790	1725	1650			16	36.1
150	1500	1900	1835	1760			17	38.1
161	1610	2010	1945	1870			18	39.9
172	1720	2120	2055	1980			19	41.9
183	1830	2230	2165	2090			20	42.6

- Notes: 1 The coil assembly moves in the direction indicated by the arrow when current flows in the order of phase U, V, and W.
- 2 When installing the linear slider, the surface should be flat to the equivalent of a maximum discrepancy of 0.02/200 mm (reference value).

• Connector Specifications for the Σ-Trac Series Linear Sliders (All Models)

View X-X

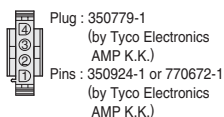

Pin No.	Signal
1	Phase-U output
2	Phase-V output
3	Phase-W output
4	FG

View Y-Y

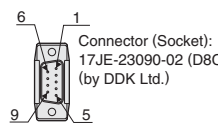

Pin No.	Signal	Pin No.	Signal
1	+5V (power supply)	6	Not used
2	Phase-U output	7	Not used
3	Phase-V output	8	Not used
4	Phase-W output	9	Not used
5	0V (power supply)	Case	Shield

View Z-Z

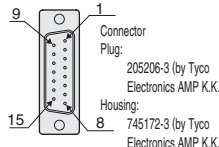

For Encoder Cable

Pin No.	Signal	Pin No.	Signal
1	Cos output (A+)	9	/Cos output (A-)
2	0 V	10	0 V sensor
3	Sin output (B+)	11	/Sin output (B-)
4	+5 V	12	5 V sensor
5	Not used	13	Not used
6	Not used	14	/Ref (R+)
7	/Ref (R-)	15	Not used
8	Not used	Case	Shield

SGT1F9 Linear Sliders

● Ratings and Specifications

Time Rating: Continuous
 Insulation Resistance: 500 VDC, 10 MΩ min.
 Ambient Temperature: 0 to 40°C
 Excitation: Permanent magnet

Withstand Voltage: 1500 VAC for one minute
 Enclosure: Self-cooled
 Ambient Humidity: 20% to 80% (no condensation)
 Allowable Winding Temperature: 130°C
 (Thermal class B)

Linear Slider Model*1		SGT1F9-□□□AH20-0
Mounted Linear Servomotor Model	SGLFW-	50A200BP
Applicable SERVOPACK Model	SGDV-	5R5
Applicable Serial Converter Unit Model	JZDP-	D006-181
Rated Force	N	200
Peak Force	N	600
Force Constant	N / Arms	67.9
Motor Constant	N / \sqrt{W}	29.3
Maximum Payload*2*3	kg	100
Movable Member Mass	kg	7.2
Total Mass	kg	See Table 1
Effective Stroke	mm	on the next page.
Resolution	μm	0.078 (20 μm / 256)
Repeatability*4	μm	±1.0

*1: Squares (□□□) are used to indicate the stroke length code shown in Tables 1.
 *2: Values obtained when the acceleration is 4.9 m/s².
 *3: Contact your Yaskawa representative if the expected payload exceeds the value indicated in the table.
 *4: Values obtained when the ambient temperature is constant.

● Performance Curves

● Force - Speed

(**A** : Continuous Duty Zone **B** : Intermittent Duty Zone)

(1) SGT1F9□

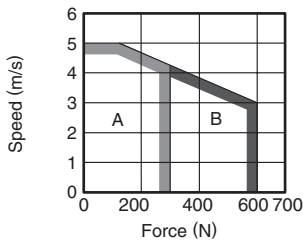

● Effective Force - Ambient Temperature

When the sensor temperature is 50°C or less
 Average speed (m/s) : 0 — 1 — 2 —
 Note: Average speed = Total movement distance (m) / cycle time (s)

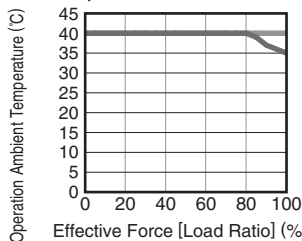

● Load Mass - Acceleration

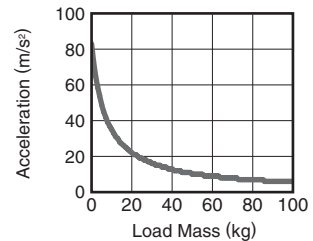

SGT1F9 Linear Sliders Units: mm

● External Dimensions

(1) SGT1F91

(See page 163 for details on each connector specifications.)

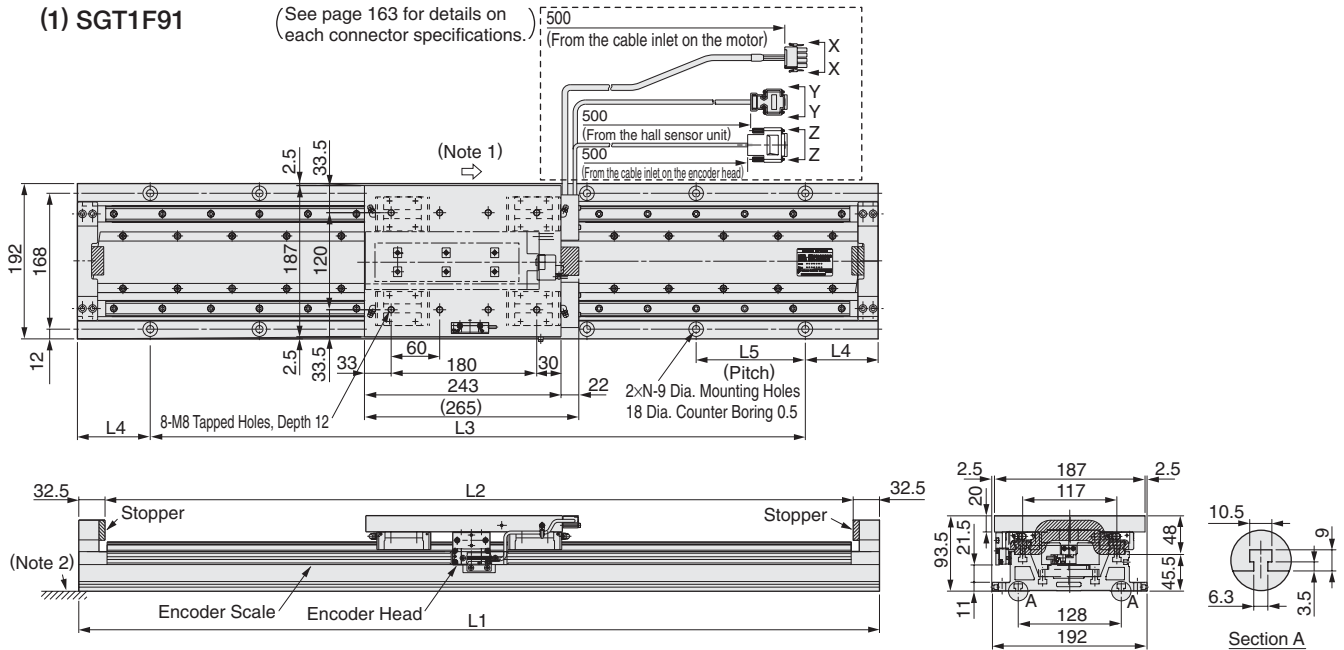

Table 1

Stroke		L1 mm	L2 mm	L3 mm	L4 mm	L5 mm	N	Total Mass kg
Code	Length							
007	70	440	375	300	70	100	4	15.9
035	350	720	655	540	90	135	5	21.3
048	480	850	785	675	87.5		6	24.1
062	620	990	925	810	90		7	26.9
075	750	1120	1055	945	87.5		8	29.5
089	890	1260	1195	1080	90		9	32.2
102	1020	1390	1325	1215	87.5		10	35.0
116	1160	1530	1465	1350	90		11	37.7
129	1290	1660	1595	1485	87.5		12	40.3
143	1430	1800	1735	1620	90		13	43.0
156	1560	1930	1865	1755	87.5		14	45.8
170	1700	2070	2005	1890	90		15	48.5
183	1830	2200	2135	2025	87.5		16	51.2

SGT1GD□, SGT1GE□, and SGT1GF□ Linear Sliders

● Ratings and Specifications

Time Rating: Continuous
 Insulation Resistance: 500 VDC, 10 MΩ min.
 Ambient Temperature: 0 to 40°C
 Excitation: Permanent magnet

Withstand Voltage: 1500 VAC for one minute
 Enclosure: Self-cooled, fan-cooled
 Ambient Humidity: 20% to 80% (no condensation)
 Allowable Winding Temperature: 130°C
 (Thermal class B)

Linear Slider Model*1		SGT1GD□-□□□AH20-0	SGT1GE□-□□□AH20-0	SGT1GF□-□□□AH20-0
Mounted Linear Servomotor Model	SGLGW-	40A140CP	40A253CP	40A365CP
Applicable SERVOPACK Model	SGDV-	R90	1R6	2R8
Applicable Serial Converter Unit Model	JZDP-	D006-252	D006-253	D006-254
Rated Force	N	47	93	140
Peak Force	N	140	280	420
Force Constant	N / Arms	61.5	61.5	61.5
Motor Constant	N / \sqrt{W}	7.8	11	13.5
Maximum Payload*2*3	kg	25	50	80
Movable Member Mass	kg	2.8	3.7	5.5
Total Mass	kg	See Table 1 on the next page.		
Effective Stroke	mm			
Resolution	μm	0.078 (20 μm / 256)		
Repeatability*4	μm	±1.0	±1.0	±1.0

*1: Squares (□□□) are used to indicate the stroke length code shown in Table 1.
 *2: Values obtained when the acceleration is 4.9 m/s².
 *3: Contact your Yaskawa representative if the expected payload exceeds the value indicated in the table.
 *4: Values obtained when the ambient temperature is constant.

● Performance Curves

● Force - Speed

(A : Continuous Duty Zone B : Intermittent Duty Zone)

● Effective Force - Ambient Temperature ● Load Mass - Acceleration

When the sensor temperature is 50°C or less
 Average speed (m/s) : 0 — 1 — 2 —
 Note: Average speed = Total movement distance (m) / cycle time (s)

(1) SGT1GD□

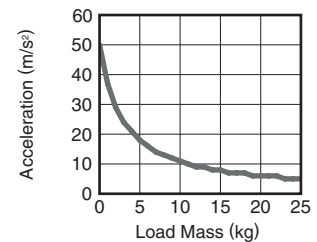
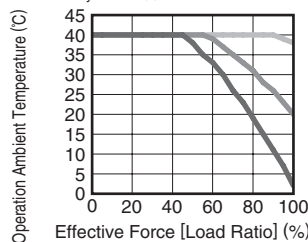
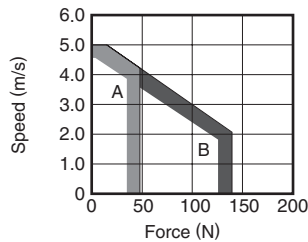

(2) SGT1GE□

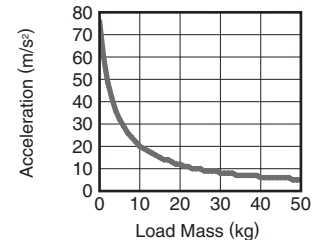
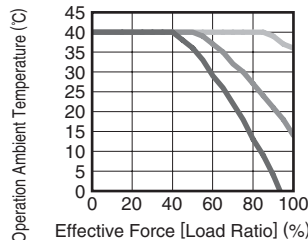
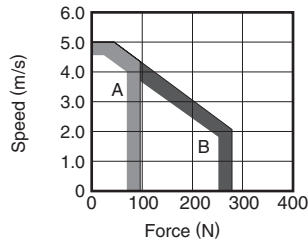

(3) SGT1GF□

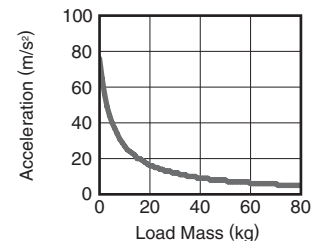
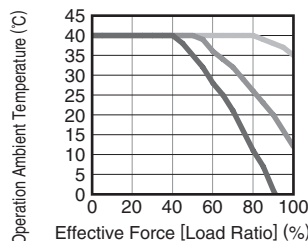
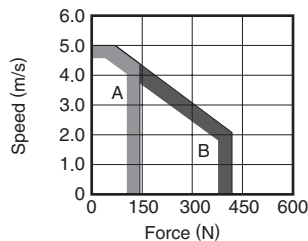

SGT1GD□, SGT1GE□, and SGT1GF□ Linear Sliders Units: mm

● External Dimensions

<Table Side View>

● SGT1GD1

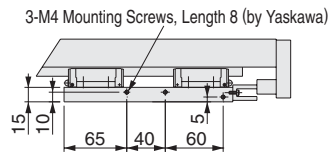

● SGT1GE1

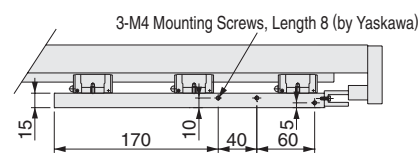

● SGT1GF1

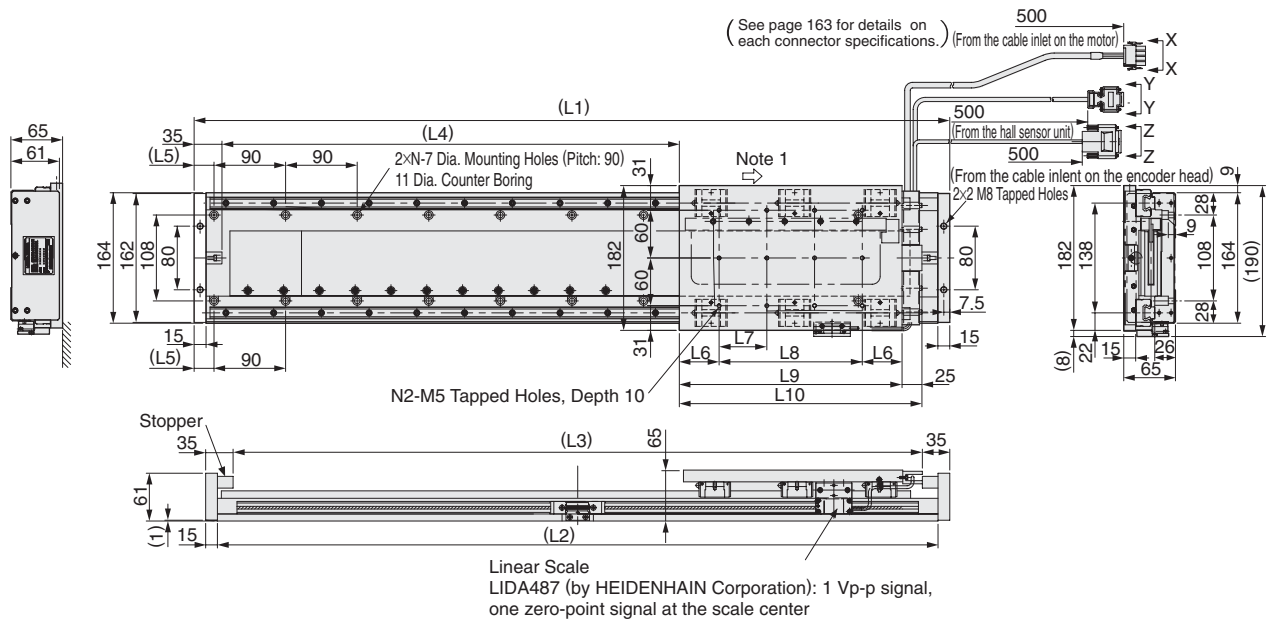
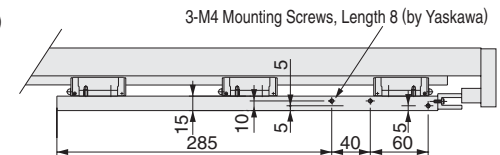

Table 1

Linear Slider Model (Mounted Linear Servomotor Model)	Stroke		Dimensions mm										N	N2	Total Mass kg
	Code	Length	L1	L2	L3	L4	L5	L6	L7	L8	L9	L10			
SGT1GD1-□□□*AH20-0 (SGLGW-40A140CP)	009	90	410	380	340	140	25	32.5	55	110	175	200	5	9	12.3
	022	220	545	515	475	275	47.5						6		15.3
	036	360	680	650	610	410	25						8		18.4
	049	490	815	785	745	545	47.5						9		21.5
	063	630	950	920	880	680	25						11		24.5
	076	760	1085	1055	1015	815	47.5						12		27.6
	090	900	1220	1190	1150	950	25						14		30.6
	103	1030	1355	1325	1285	1085	47.5						15		33.7
	117	1170	1490	1460	1420	1220	25						17		36.8
	130	1300	1625	1595	1555	1355	47.5						18		39.8
SGT1GE1-□□□*AH20-0 (SGLGW-40A253CP)	012	120	545	515	475	170	47.5	50	60	180	280	305	6	12	16.8
	025	250	680	650	610	305	25						8		19.9
	039	390	815	785	745	440	47.5						9		22.9
	052	520	950	920	880	575	25						11		26.0
	066	660	1085	1055	1015	710	47.5						12		29.0
	079	790	1220	1190	1150	845	25						14		32.1
	093	930	1355	1325	1285	980	47.5						15		35.2
	106	1060	1490	1460	1420	1115	25						17		38.2
	110	1100	1535	1505	1465	1160	47.5						17		39.3
	120	1200	1625	1595	1555	1250	47.5						18		41.3
SGT1GF1-□□□*AH20-0 (SGLGW-40A365CP)	014	140	680	650	610	190	25	47.5	60	300	395	420	8	18	21.1
	027	270	815	785	745	325	47.5						9		24.2
	041	410	950	920	880	460	25						11		27.3
	054	540	1085	1055	1015	595	47.5						12		30.3
	068	680	1220	1190	1150	730	25						14		33.4
	081	810	1355	1325	1285	865	47.5						15		36.4
	095	950	1490	1460	1420	1000	25						17		39.5
	108	1080	1625	1595	1555	1135	47.5						18		42.6

*: Squares (□□□) are used to indicate the stroke length code shown in Table 1.

Notes: 1 The coil assembly moves in the direction indicated by the arrow when current flows in the order of phase U, V, and W.

2 When installing the linear slider, the surface should be flat to the equivalent of a maximum discrepancy of 0.02/200 mm (reference value).

SGT1GG□, SGT1GH□, and SGT1GI□ Linear Sliders

● Ratings and Specifications

Time Rating: Continuous
 Insulation Resistance: 500 VDC, 10 MΩ min.
 Ambient Temperature: 0 to 40°C
 Excitation: Permanent magnet

Withstand Voltage: 1500 VAC for one minute
 Enclosure: Self-cooled, fan-cooled
 Ambient Humidity: 20% to 80% (no condensation)
 Allowable Winding Temperature: 130°C
 (Thermal class B)

Linear Slider Model*1		SGT1GG□-□□□AH20-0	SGT1GH□-□□□AH20-0	SGT1GI□-□□□AH20-0
Mounted Linear Servomotor Model	SGLGW-	60A140CP	60A253CP	60A365CP
Applicable SERVOPACK Model	SGDV-	1R6	2R8	5R5
Applicable Serial Converter Unit Model	JZDP-	D006-258	D006-259	D006-260
Rated Force	N	70	140	210
Peak Force	N	220	440	660
Force Constant	N / Arms	66.6	66.6	66.6
Motor Constant	N / √W	11.1	15.7	19.2
Maximum Payload*2*3	kg	40	80	110
Movable Member Mass	kg	2.9	3.9	5.7
Total Mass	kg	See Table 1 on the next page.		
Effective Stroke	mm			
Resolution	μm	0.078 (20 μm / 256)		
Repeatability*4	μm	±1.0	±1.0	±1.0

*1: Squares (□□□) are used to indicate the stroke length code shown in Table 1.
 *2: Values obtained when the acceleration is 4.9 m/s².
 *3: Contact your Yaskawa representative if the expected payload exceeds the value indicated in the table.
 *4: Values obtained when the ambient temperature is constant.

● Performance Curves

● Force - Speed

(A : Continuous Duty Zone B : Intermittent Duty Zone)

● Effective Force - Ambient Temperature ● Load Mass - Acceleration

When the sensor temperature is 50°C or less
 Average speed (m/s) : 0 — 1 — 2 —
 Note: Average speed = Total movement distance (m) / cycle time (s)

(1) SGT1GG□

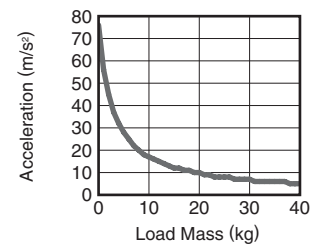
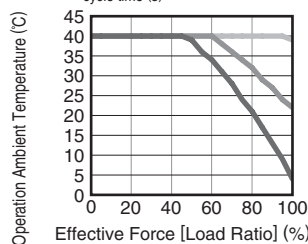
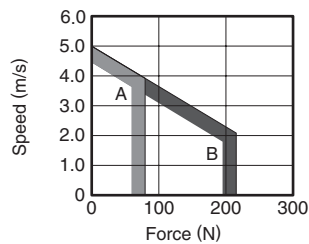

(2) SGT1GH□

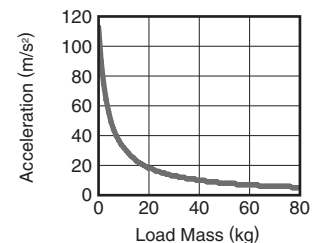
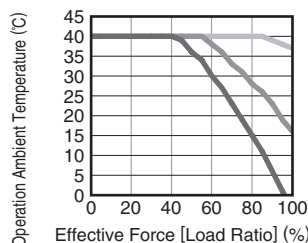
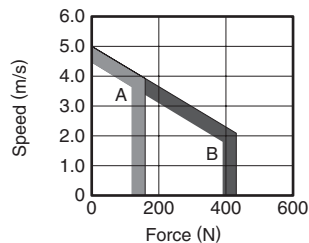

(3) SGT1GI□

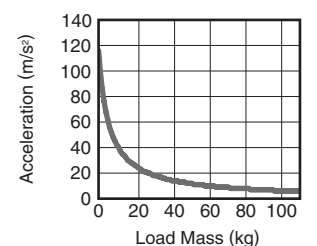
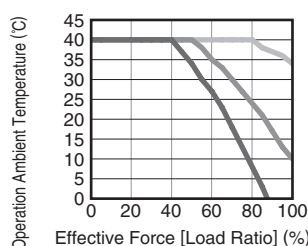
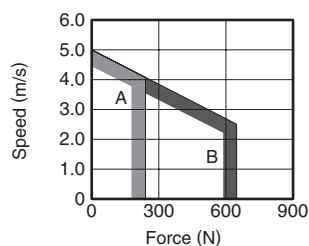

SGT1GG□, SGT1GH□, and SGT1GI□ Linear Sliders Units: mm

● External Dimensions

<Table Side View>

● SGT1GG1

3-M4 Mounting Screws, Length 8 (by Yaskawa)

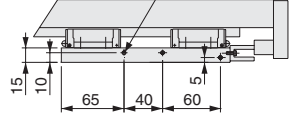

● SGT1GH1

3-M4 Mounting Screws, Length 8 (by Yaskawa)

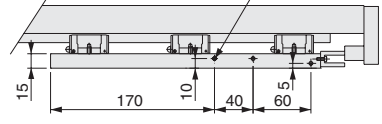

● SGT1GI1

6-M4 Mounting Screws, Length 8 (by Yaskawa)
(Used for connector box etc.)

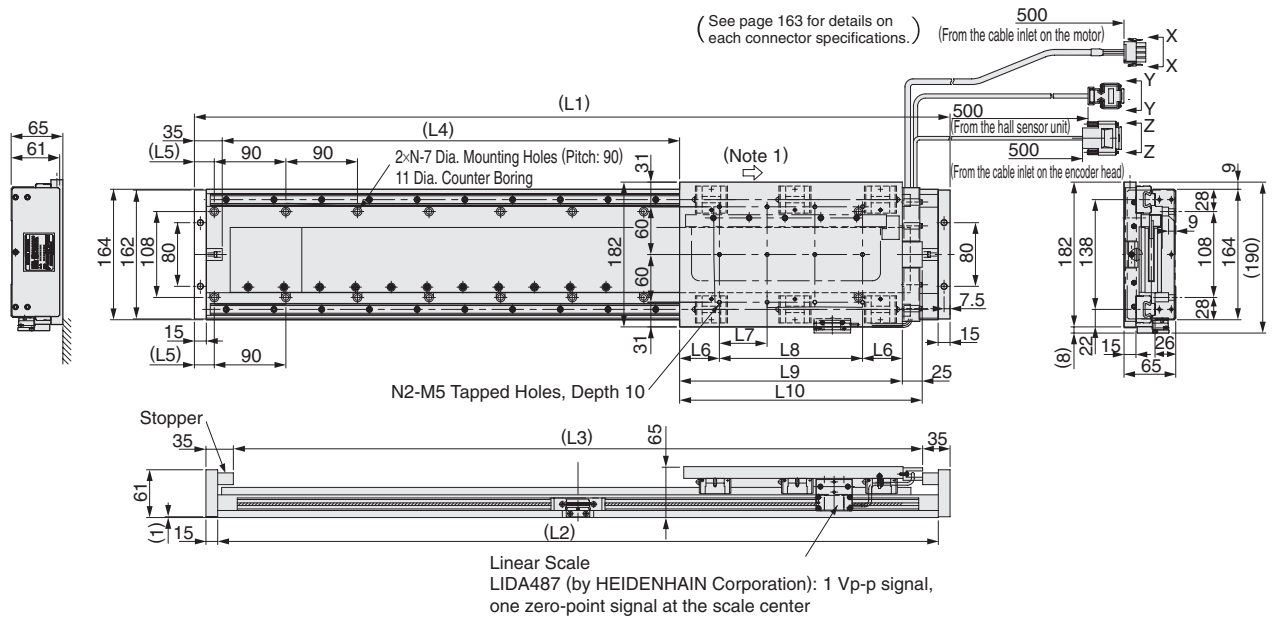
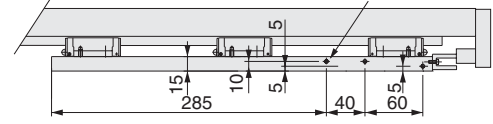

Table 1

Linear Slider Model (Mounted Linear Servomotor Model)	Stroke		Dimensions mm										N	N2	Total Mass kg
	Code	Length	L1	L2	L3	L4	L5	L6	L7	L8	L9	L10			
SGT1GG1-□□□*AH20-0 (SGLGW-60A140CP)	009	90	410	380	340	140	25	32.5	55	110	175	200	5	9	12.3
	022	220	545	515	475	275	47.5						6		15.4
	036	360	680	650	610	410	25						8		18.5
	049	490	815	785	745	545	47.5						9		21.5
	063	630	950	920	880	680	25						11		24.6
	076	760	1085	1055	1015	815	47.5						12		27.7
	090	900	1220	1190	1150	950	25						14		30.7
	103	1030	1355	1325	1285	1085	47.5						15		33.8
	117	1170	1490	1460	1420	1220	25						17		36.9
	130	1300	1625	1595	1555	1355	47.5						18		39.9
SGT1GH1-□□□*AH20-0 (SGLGW-60A253CP)	012	120	545	515	475	170	47.5	50	60	180	280	305	6	12	17.0
	025	250	680	650	610	305	25						8		20.0
	039	390	815	785	745	440	47.5						9		23.1
	052	520	950	920	880	575	25						11		26.1
	066	660	1085	1055	1015	710	47.5						12		29.2
	079	790	1220	1190	1150	845	25						14		32.3
	093	930	1355	1325	1285	980	47.5						15		35.3
	106	1060	1490	1460	1420	1115	25						17		38.4
	110	1100	1535	1505	1465	1160	47.5						17		39.4
	120	1200	1625	1595	1555	1250	47.5						18		41.5
SGT1GI1-□□□*AH20-0 (SGLGW-60A365CP)	014	140	680	650	610	190	25	47.5	60	300	395	420	8	18	21.4
	027	270	815	785	745	325	47.5						9		24.4
	041	410	950	920	880	460	25						11		27.5
	054	540	1085	1055	1015	595	47.5						12		30.5
	068	680	1220	1190	1150	730	25						14		33.6
	081	810	1355	1325	1285	865	47.5						15		36.7
	095	950	1490	1460	1420	1000	25						17		39.7
	108	1080	1625	1595	1555	1135	47.5						18		42.8

*: Squares (□□□) are used to indicate the stroke length code shown in Table 1.

Notes: 1 The coil assembly moves in the direction indicated by the arrow when current flows in the order of phase U, V, and W.

2 When installing the linear slider, the surface should be flat to the equivalent of a maximum discrepancy of 0.02/200 mm (reference value).

Selecting Cables and Connectors

● Connection diagrams

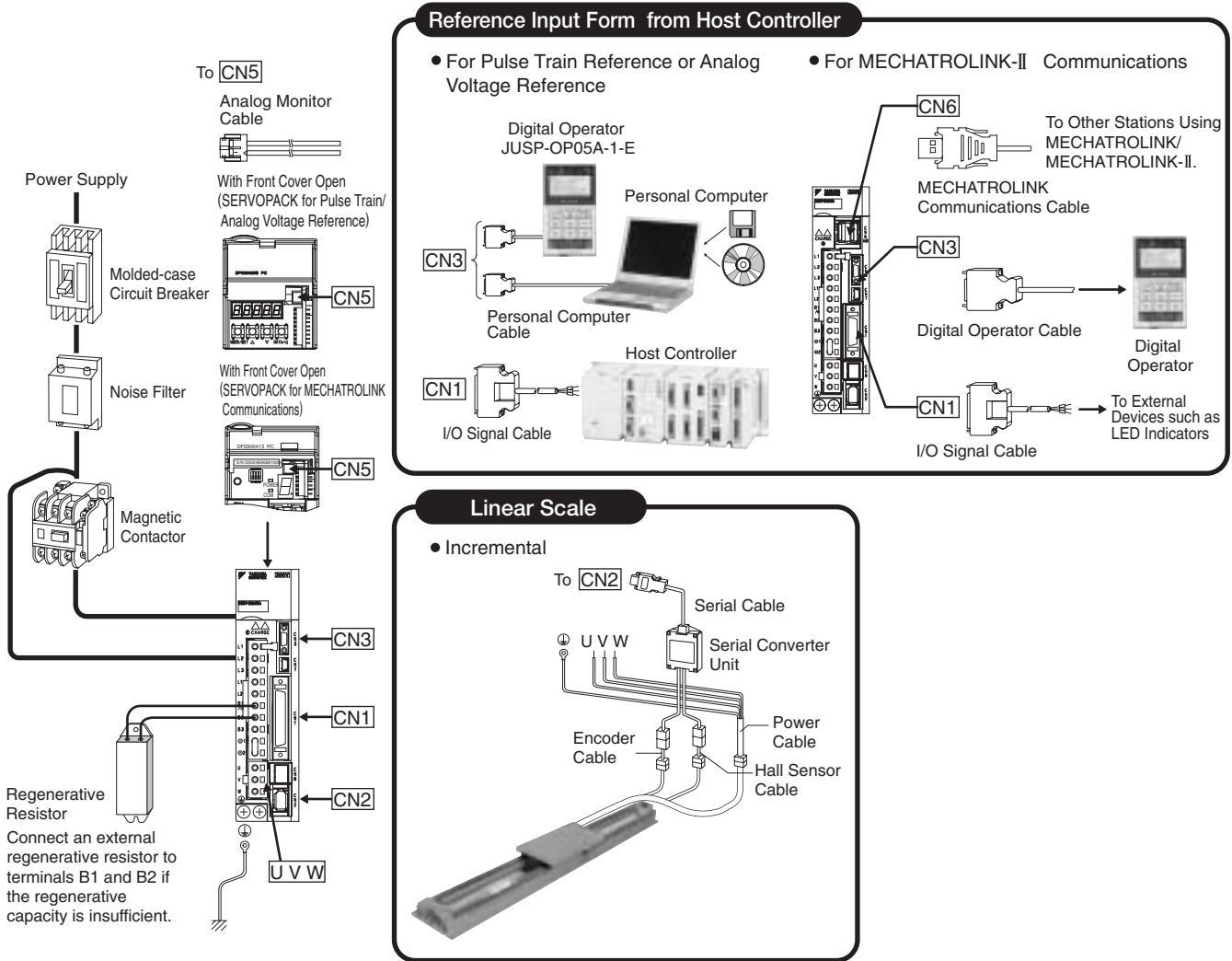

● Applicable Cables and Connectors

Contact Yaskawa Controls Co., Ltd.

Motor Type	Linear Scale Type	Servodrive		Motor Cable		Linear Scale Connection Cables		
		Σ-Trac Series Model	SERVOPACK Model SGDV-	SERVOPACK ↔ Motor	Serial Converter Unit Model	[CN2] ↔ Serial Converter Unit	Serial Converter Unit ↔ Linear Encoder	
			Three-phase 200 V	Power Cable (Flexible Type)		Serial Cable (Flexible Type)	Encoder Cable (Flexible Type)	
Moving Coil (MC)	Incremental	SGT□F3□-□□□AH20-0	1R6	JZSP-CLN11-□□-E	D006-019	□□ → 01 = 1 m 03 = 3 m 05 = 5 m 10 = 10 m 15 = 15 m 20 = 20 m	□□ → 01 = 1 m 03 = 3 m 05 = 5 m 10 = 10 m 15 = 15 m	
		SGT□F4□-□□□AH20-0	3R8	JZSP-CLN11-□□-E	D006-020			
		SGT□F9□-□□□AH20-0	5R5	JZSP-CLN21-□□-E	D006-181			
		SGT□GD□-□□□AH20-0	R90	JZSP-CLN11-□□-E	D006-252			
		SGT□GE□-□□□AH20-0	1R6	JZSP-CLN11-□□-E	D006-253			
		SGT□GF□-□□□AH20-0	2R8	JZSP-CLN11-□□-E	D006-254			
		SGT□GG□-□□□AH20-0	1R6	JZSP-CLN11-□□-E	D006-258			
		SGT□GH□-□□□AH20-0	2R8	JZSP-CLN11-□□-E	D006-259			
		SGT□GI□-□□□AH20-0	5A5	JZSP-CLN11-□□-E	D006-260			

Selecting Cables and Connectors

● Detail Drawings: Serial Converter Units for Linear Scales by HEIDENHAIN Corporation

- JZDP-D006-□□□□-E
(With Hall Sensor Cable)

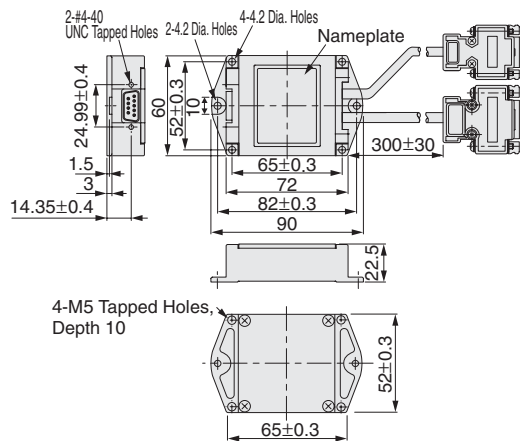

- JZDP-D003-□□□□-E
(Without Hall Sensor Cable)

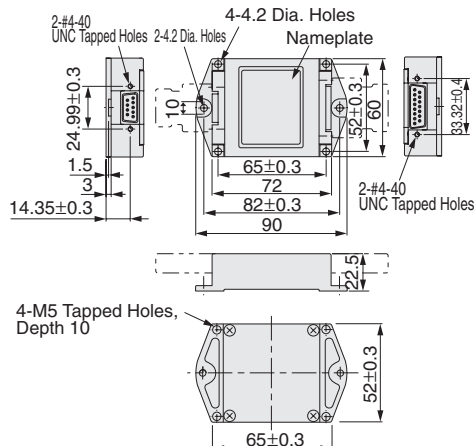

● Details on Connectors

CN1

SERVOPACK End Serial Data Output

1717-series Connector :
17JE-13090-27 (Socket)
by DDK Ltd.

Pin No.	Signal	Pin No.	Signal
1	+5V	6	Phase-/S output
2	Phase-/S output	7	Not used
3	Not used	8	Not used
4	Not used	9	Not used
5	0V	Case	Shield

CN2

Linear Scale End Analog Signal Input

1717-series Connector :
17JE-13150-02 (D8C)
(Socket) by DDK Ltd.

Pin No.	Signal	Pin No.	Signal
1	cos input (A+)	9	/cos input (A-)
2	0V	10	0V sensor
3	sin input (B+)	11	/sin input (B-)
4	+5V	12	5V sensor
5	Not used	13	Not used
6	Not used	14	Ref input (R+)
7	/Ref input (R-)	15	Not used
8	0V	Case	Shield

CN3

Linear Scale End Hall Sensor Signal Input

17-series Connector :
17JE-13090
by DDK Ltd.

Pin No.	Signal	Pin No.	Signal
1	+5V	6	Not used
2	Phase-U input	7	Not used
3	Phase-V input	8	Not used
4	Phase-W input	9	Not used
5	0V	Case	Shield

Serial Converter Unit→Hall Sensor	Pulse-train or Analog Voltage Reference			MECHATROLINK Communications			Cables for Setting Devices/Monitors	
	I/O Signal Connector CN1			I/O Signal Connector CN1			[CN3]→Setting Devices	[CN5]
Hall Sensor Cable (Flexible Type)	Connector Terminal Block Converter Unit	Cable with Loose Wires at One End	Connector Kit (CN1)	Connector Terminal Block Converter Cable	Connector Kit (CN1)	MECHATROLINK Communications Connector CN6A or CN6B	Personal Computer Cable	Analog Monitor Cable
JZSP-CLL10-□□□-E □□→01 = 1 m 03 = 3 m 05 = 5 m 10 = 10 m 15 = 15 m Note: Required only if using a JZDP-D006 serial converter.	JZSP-TA50P-E □→None = 0.5 m 1 = 1 m 2 = 2 m	JZSP-CSI01-□□-E □→1 = 1 m 2 = 2 m 3 = 3 m	JZSP-CSI9-1-E	JZSP-TA26P-□□-E □→None = 0.5 m 1 = 1 m 2 = 2 m	JZSP-CSI9-2-E	MECHATROLINK communications cable: JEPMC-W6002-□□□-E □□→A5 = 0.5 m 01 = 1 m <small>[To specify the desired cable length, add the length to the end of the model number, as indicated here by the squares (□□), when ordering.]</small> MECHATROLINK terminator: JEPMC-W6022-E	JZDP-CMS02-E (2 m)	JZSP-CA01-E (1 m)

Analog Voltage/Pulse Train Reference Type SERVOPACKs

SGDV-01

(For Rotary Servomotors)

SGDV-05

(For Linear Servomotors)



Model Designations

SGDV - R70 A 01 A

Σ -V Series
SGDV SERVOPACK

Current

Voltage	Code	Applicable Servomotor Max. Capacity kW
200 V	R70	0.05
	R90	0.1
	1R6	0.2
	2R8	0.4
	3R8	0.5
	5R5	0.75
400 V	1R9	0.5
	3R5	1.0
	5R4	1.5
	8R4	2.0
	120	3.0
	170	5.0

Options

Code	Specifications
Blank	Base-mounted (standard)
001000	Rack-mounted (optional)

Design Revision Order
A, B...

Interface

Code	Specifications
01	Analog voltage/pulse train reference type (for rotary servomotors)
05	Analog voltage/pulse train reference type (for linear servomotors)

Voltage

Code	Specifications
A	200 VAC
D	400 VAC

Features

- Unprecedented ease-of-use through cutting-edge technology
New tuning-less function means no adjustment needed.
Impressive load regulation with strengthened vibration suppression function.
- Slashed setup time
Setup wizard function and wiring conformation function of engineering tool SigmaWin+ allows easy setup just by watching the monitor.
- High response characteristics at 1 kHz min.
New advanced autotuning.
Reduced positioning time through model following control, and smooth machine control enabled by vibration suppression function.

Ratings

SERVOPACK Model	SGDV-	R70A	R90A	1R6A	2R8A	3R8A	5R5A	1R9D	3R5D	5R4D	8R4D	120D	170D
Main Circuit		Three-phase 200 to 230 VAC+10% to -15% 50/60 Hz						Three-phase 380 to 480 VAC+10% to -15% 50/60 Hz					
Control Circuit		Single-phase 200 to 230 VAC+10% to -15% 50/60 Hz						24 VDC ±15%					
Applicable Servomotor Max. Capacity	kW	0.05	0.1	0.2	0.4	0.5	0.75	0.5	1	1.5	2	3	5
Continuous Output Current	Arms	0.66	0.91	1.6	2.8	3.8	5.5	1.9	3.5	5.4	8.4	11.9	16.5
Max. Output Current	Arms	2.1	2.9	6.5	9.3	11	16.9	5.5	8.5	14	20	28	42

Specifications

Items			Specifications
Input Power Supply	Main Circuit	200 V	Three-phase 200 to 230 VAC +10% to -15% 50/60 Hz
		400 V *1	Three-phase 380 to 480 VAC +10% to -15% 50/60 Hz
	Control Circuit	200 V	Single-phase 200 to 230 VAC +10% to -15% 50/60 Hz
		400 V *1	24 VDC ±15%
Control Method			For 200 V, for 400 V, three-phase full-wave rectification IGBT PWM control, sine-wave driven
Feedback	Rotary Servomotors	Serial encoder: 13-bit (incremental encoder) Serial encoder: 20-bit (incremental/absolute encoder) 4 Mb/s communications	
	Linear Servomotors	Serial Converter 4 Mb/s communications	
Operating Conditions	Ambient/Storage Temperature	Ambient temperature: 0 to +55°C, storage temperature: -20 to +85°C	
	Ambient/Storage Humidity	90%RH or less (no condensation)	
	Vibration/Impact Resistance	Vibration resistance: 4.9 m/s ² , impact resistance: 19.6 m/s ²	
	Protection class/Pollution degree	Protection class: IP 1X, pollution degree: 2 Do not use SERVOPACKs in the following locations: · Locations subject to corrosive or flammable gasses · Locations subject to exposure to water, oil, or chemicals · Locations subject to dust, including iron dust, and salts	
	Others	Do not use SERVOPACKs in the following locations: · Locations subject to static electricity noise, strong electromagnetic/magnetic fields, radioactivity	
Elevation			1000 m or less
Compliant Standards			UL 508C EN50178, EN55011 class A group 1, EN61800-3, EN61800-5-1
Configuration			Base-mounted (Rack mounting available as an option for some models.)
Performance	Speed Control Range		1:5000 (The lowest speed of the speed control range is the speed at which the servomotor will not stop with a rated torque load.)
	Speed Regulation*2	Load Regulation	0% to 100% load: ±0.01% max. (at rated speed)
		Voltage Regulation	Rated voltage: ±10% : 0% (at rated speed)
		Temperature Regulation	25±25°C : ±0.1% max. (at rated speed)
	Torque Control Tolerance (Repeatability)		±1%
Soft Start Time Setting		0 to 10 s (can be set individually for acceleration and deceleration.)	
I/O Signals	Encoder Output Pulses		Phase A, phase B, phase C: line driver output The number of dividing pulse: Any setting ratio is available.
Communications	RS-422A Communications	Interface	Digital operator, RS-422A port of personal computers etc.
		1:N communications	RS-422A port: N= 15 max. available
		Axis address setting	Set by parameters
	USB Communications	Function	Status display, parameter settings, adjustment functions, utility functions, parameter copy functions
		Interface	Personal computers (application: SigmaWin+)
		1:N communications	Compliant with USB1.1 standard
Function		Status display, parameter settings, adjustment functions, utility functions, parameter copy functions, waveform trace	
Display	Power Charge		CHARGE for main circuit power supply input confirmation LED (Red) 1 ch
Analog Monitor			Analog monitor connector built in for monitoring speed, torque and other reference signals. Number of channels: 2 ch
Protective Functions			Overcurrent, Overvoltage, low voltage, overload, regeneration error
Regenerative Processing			200 VAC SGDV-R70A, -R90A, -R6A, -2R8A: External regenerative resistor (optional) 200 VAC SGDV-3R8A, -5R5A: Built-in regenerative resistor 400 VAC model: Built-in regenerative resistor
Utility Functions			Alarm trace back, JOG operation, origin search, etc.
Safety Functions	Input		/HWBB1, /HWBB2: Hard wire base block signal
	Output		EDM1: Status monitor (fixed output) of built-in safety circuit
Option Card Function	Feedback		Serial encoder communications input for fully-closed loop control

*1: SGDV-□□□□05 SERVOPACK has no 400 V model.

*2: Speed regulation is defined as follows:

$$\text{Speed regulation} = \frac{\text{No-load motor speed} - \text{Total load motor speed}}{\text{Rated motor speed}} \times 100\%$$

The motor speed may change due to voltage variations or amplifier drift and changes in processing resistance due to temperature variation. The ratio of speed changes to the rated speed represent speed regulation due to voltage and temperature variations.

Specifications

● Rotary Servomotors

Items		Specifications	
I/O Signal	Sequence Input	Number of Channels	7 ch
		Function	Signal allocations and positive/negative logics can be modified. Servo ON (/SVON), P control (/P-CON), alarm reset (/ALM-RST), forward run prohibited (P-OT), reverse run prohibited (N-OT), forward torque limit (/P-CL), reverse torque limit (/N-CL), internal speed setting switching, control mode switching (/C-SEL), zero clamp (/ZCLAMP), reference pulse inhibit (/INHIBIT), gain changeover
	Sequence Output	Number of Channels	3 ch
		Function	Signal allocations and positive/negative logics can be modified. Positioning completion (/COIN), speed coincidence detection (/V-CMP), servomotor rotation detection (/TGON), servo ready (/S-RDY), torque limit detection (/CLT), speed limit detection (/VLT), brake interlock (/BK), warning (/WARN), NEAR (/NEAR)
Panel Operator		Display	7-segment 5-digit LED (Red)
		Switch	Push switch: 4 ch
Torque Control	Analog Input	Reference Voltage	±3 VDC (Variable setting range: ±1 to 10 VDC) at rated torque, max. input voltage: ±12 V
		Input Impedance	About 14 kΩ min.
		Circuit Time Constant	30 μs
Speed Control	Analog Input	Reference Voltage	±6 VDC (variable setting range: ±2 to 10 VDC) at rated speed, max. input voltage: ±12 V
		Input Impedance	About 14 kΩ min.
		Circuit Time Constant	30 μs
	Set Speed Reference	Rotation Direction Selection	Switches the direction by /P-CON
		Speed Selection	Speed 1 to 3 selection
Function	Soft Start Setting	0 to 10 s (can be set individually for acceleration and deceleration.)	
Position Control	Reference Pulse	Type	Sign + pulse train, 90° phase difference 2-phase pulse (phase A + phase B), or CCW + CW pulse train
		Form	Non-insulated line driver (+5 V level), open collector
		Frequency*	×1 multiplier: 4 Mpps ×2 multiplier: 2 Mpps ×4 multiplier: 1 Mpps Open collector: 200 kpps Frequencies drop when the duties have errors.
	Clear Signal	Function	Clears error pulse by external signals.
		Form	Applicable to line driver, open collector
Others	Alarm Code Output	3-bit, open collector output (non-insulated)	
	SEN signal	Included	

*: If the maximum reference frequency exceeds 1 Mpps, use a shielded cable for I/O signals and ground both ends of the shield. Connect the shield at the SERVOPACK to the connector shell.

Specifications

●Linear Servomotors

Items		Specifications	
I/O Signal	Sequence Input	Number of Channels	7 ch
		Function	Signal allocations and positive/negative logics can be modified. Servo ON (/SVON), P control (/P-CON), alarm reset (/ALM-RST), forward run prohibited (P-OT), reverse run prohibited (N-OT), forward force limit (/P-CL), reverse force limit (/N-CL), internal speed setting switching, control mode switching (/C-SEL), zero clamp (/ZCLAMP), reference pulse inhibit (/INHIBIT), gain changeover
	Sequence Output	Number of Channels	3 ch
		Function	Signal allocations and positive/negative logics can be modified. Positioning completion (/COIN), speed coincidence detection (/V-CMP), servomotor movement detection (/TGON), servo ready (/S-RDY), force limit detection (/CLT), speed limit detection (/VLT), brake interlock (/BK), warning (/WARN), NEAR (/NEAR)
Panel Operator		Display	7-segment 5-digit LED (Red)
		Switch	Push switch: 4 ch
Force Control	Analog Input	Reference Voltage	±3 VDC (variable setting range: ±1 to 10 VDC), max. input voltage: ±12 V
		Input Impedance	About 14 kΩ min.
		Circuit Time Constant	30 μs
Speed Control	Analog Input	Reference Voltage	±6 VDC (variable setting range: ±2 to 10 VDC) at rated speed, max. input voltage: ±12 V
		Input Impedance	About 14 kΩ min.
		Circuit Time Constant	30 μs
	Set Speed Reference	Movement Direction Selection	/P-CON signal
		Speed Selection	Speed 1 to 3 selection
Function	Soft Start Setting	0 to 10 s (can be set individually for acceleration and deceleration.)	
Position Control	Reference Pulse	Type	Sign+pulse train, 90° phase difference 2-phase pulse (phase A+phase B), or CCW+CW pulse train
		Form	Non-insulated line driver (+5 V level), open collector
		Frequency	×1 multiplier: 4 Mpps ×2 multiplier: 2 Mpps ×4 multiplier: 1 Mpps Open collector: 200 kpps Frequencies drop when the duty changes.
	Clear Signal	Function	Clears error pulse by external signals.
		Form	Applicable to line driver, open collector
Others	Alarm Code Output	3-bit, open collector output (non-insulated)	
	SEN signal	Included	

Power Supply Capacities and Power Losses

The following table shows SERVOPACK's power supply capacities and power losses at the rated output.

Main Circuit Power Supply	Applicable Servomotor Max. Capacity kW	SERVOPACK Model SGD-	Power Supply Capacity kVA	Output Current A	Main Circuit Power Loss W	Regenerative Resistor Power Loss W	Control Circuit Power Loss W	Total Power Loss W
Three-phase 200 V	0.05	R70A	0.2	0.66	5.1	—	17	22.1
	0.1	R90A	0.3	0.91	7.3			24.3
	0.2	1R6A	0.6	1.6	13.5			30.5
	0.4	2R8A	1	2.8	24.0	41.0		
	0.5	3R8A	1.4	3.8	20.1	8		45.1
	0.75	5R5A	1.6	5.5	43.8			68.8
Three-phase 400 V	0.5	1R9D	1.1	1.9	24.6	14	21	59.6
	1.0	3R5D	2.3	3.5	46.1			81.1
	1.5	5R4D	3.5	5.4	71.3			106.3
	2.0	8R4D	4.5	8.4	77.9	28		130.9
	3.0	120D	7.1	11.9	108.7			161.7
	5.0	170D	11.7	16.5	161.1			36

Notes: 1 SGD-V-R70A, -R90A, -1R6A, and -2R8A SERVOPACKs do not have built-in regenerative resistors. If the regenerative energy exceeds the specified value, connect an external regenerative resistor.

2 Regenerative resistor power losses are allowable losses. Take the following action if this value is exceeded.

·Remove the lead from the internal regenerative resistor in the SERVOPACK. (SGDV-3R8A, -5R5A, and 400-V SERVOPACKs)

·Install an external regenerative resistor.

3 External regenerative resistors are options.

External Dimensions Units: mm

● Base-mounted SERVOPACKS

(1) Three-phase 200 VAC, Model: SGDV-R70A0□A, -R90A0□A, and -1R6A0□A

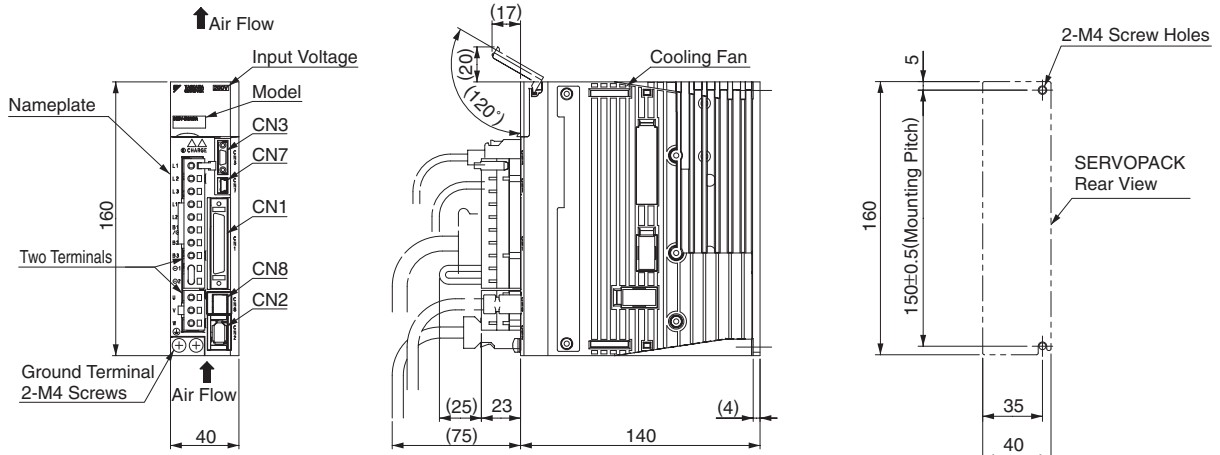

Mounting Hole Diagram

Approx. Mass: 0.9 kg

(2) Three-phase 200 VAC, Model: SGDV-2R8A0□A

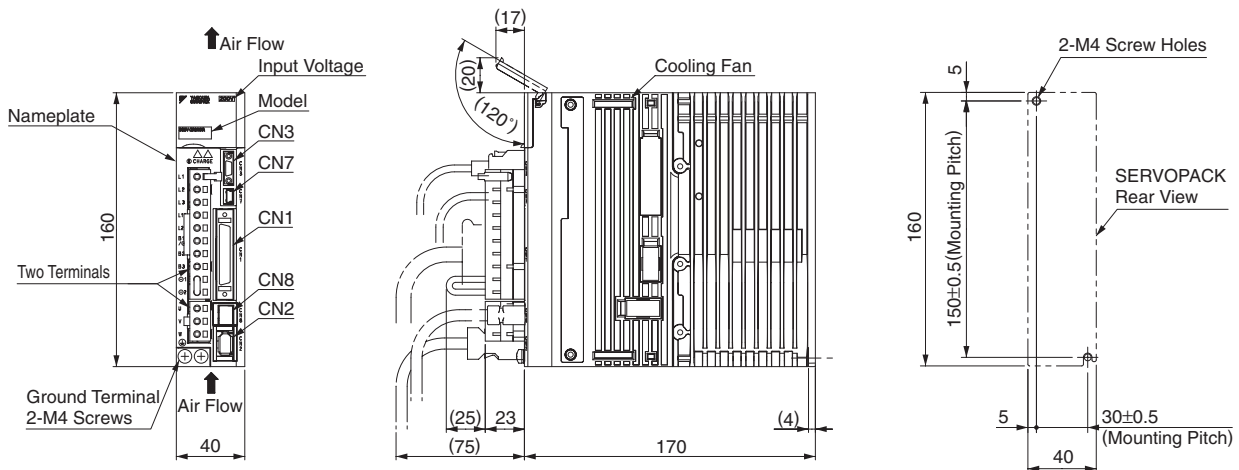

Mounting Hole Diagram

Approx. Mass: 1.0 kg

(3) Three-phase 200 VAC, Model: SGDV-3R8A0□A and -5R5A0□A

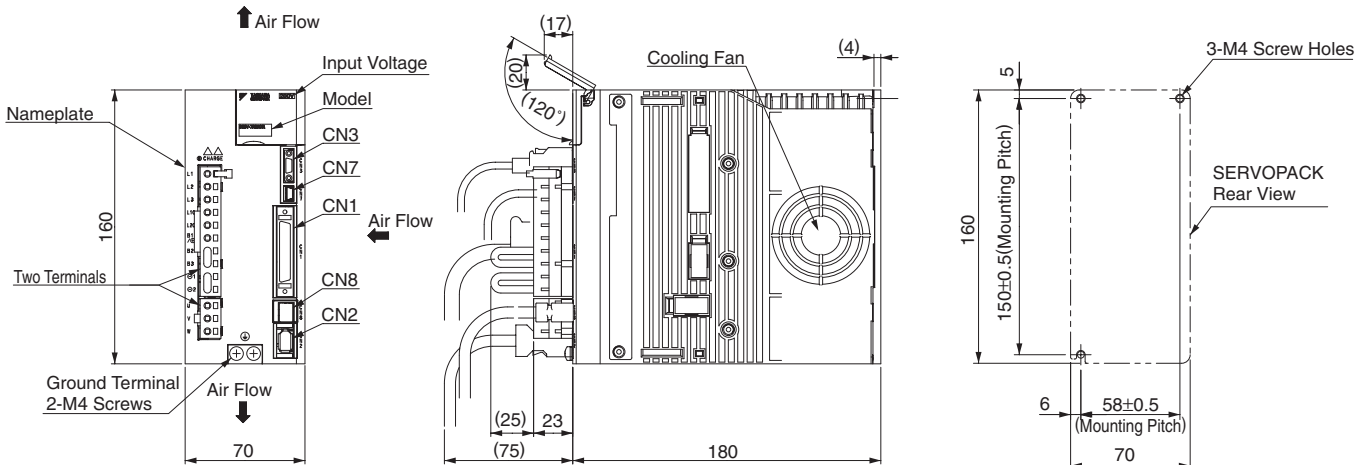

Mounting Hole Diagram

Approx. Mass: 1.5 kg

External Dimensions Units: mm

(4) Three-phase 400 VAC, Model: SGDV-1R9D0□A, -3R5D0□A, and -5R4D0□A

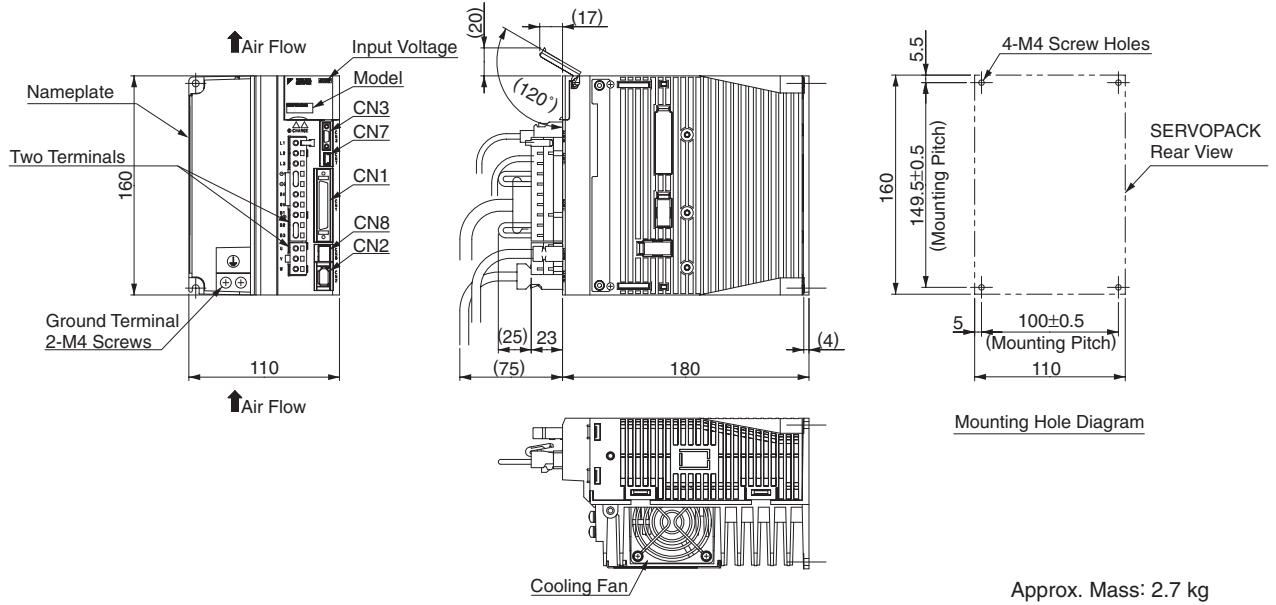

(5) Three-phase 400 VAC, Model: SGDV-8R4D0□A and -120D0□A

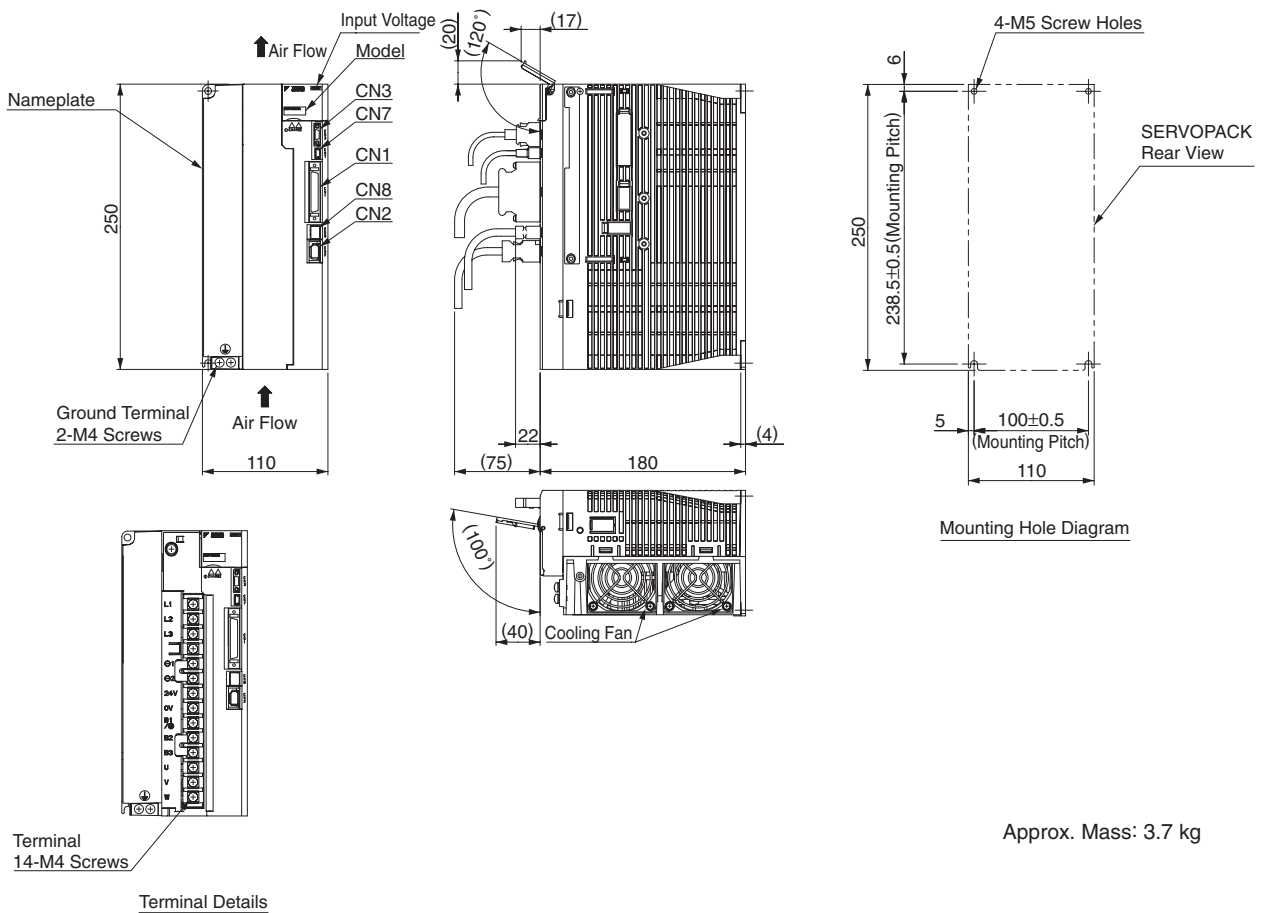

External Dimensions Units: mm

(6) Three-phase 400 VAC, Model: SGDV-170D0□A

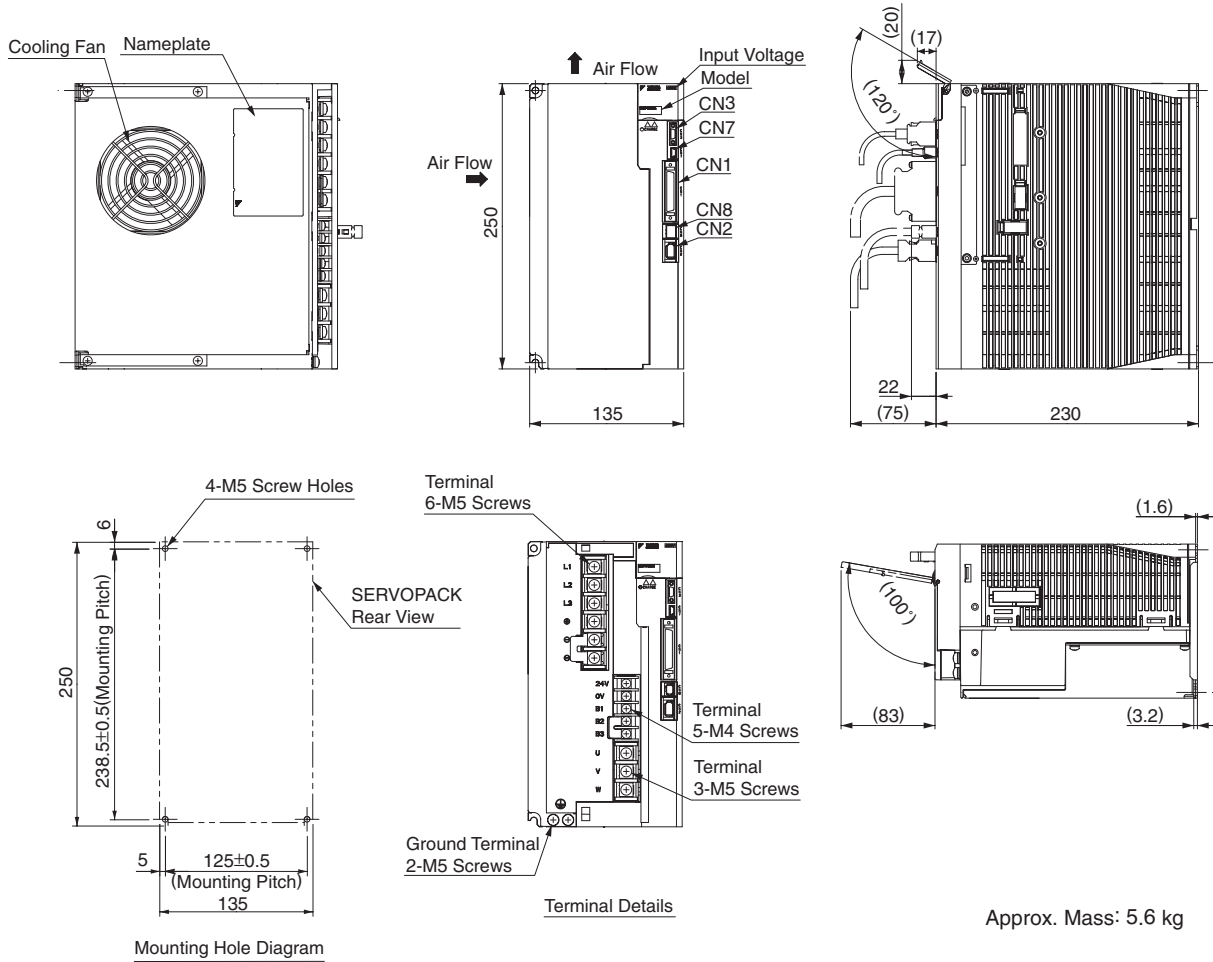

Connectors for Base-mounted SERVOPACKs

Port	Model	Pin	Manufacturer
CN1	10250-52A2PL	50	Sumitomo 3M Ltd.
CN2	53984-0671	6	Molex Japan Co., Ltd.
CN3	HDR-EC14LFDTN-SLE-PLUS	14	Honda Tsushin Kogyo Co., Ltd.
CN7	MNC23-5K5H00	5	ADVANCED-CONNECTEK INC.
CN8	1981080-1	8	Tyco Electronics AMP K.K.

Note: The connectors above or their equivalents are used for SERVOPACKs.

External Dimensions Units: mm

● **Rack-mounted SERVOPACKS**

(1) Three-phase 200 VAC, Model: SGDV-R70A0□A001, -R90A0□A001, and -1R6A0□A001

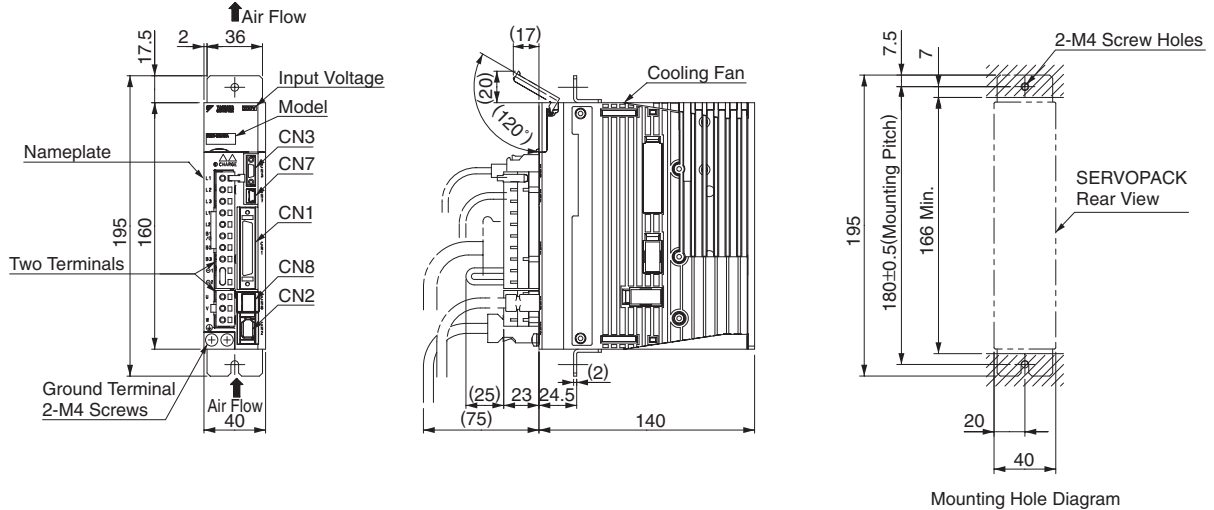

Mounting Hole Diagram

Approx. Mass: 0.9 kg

(2) Three-phase 200 VAC, Model: SGDV-2R8A0□A001

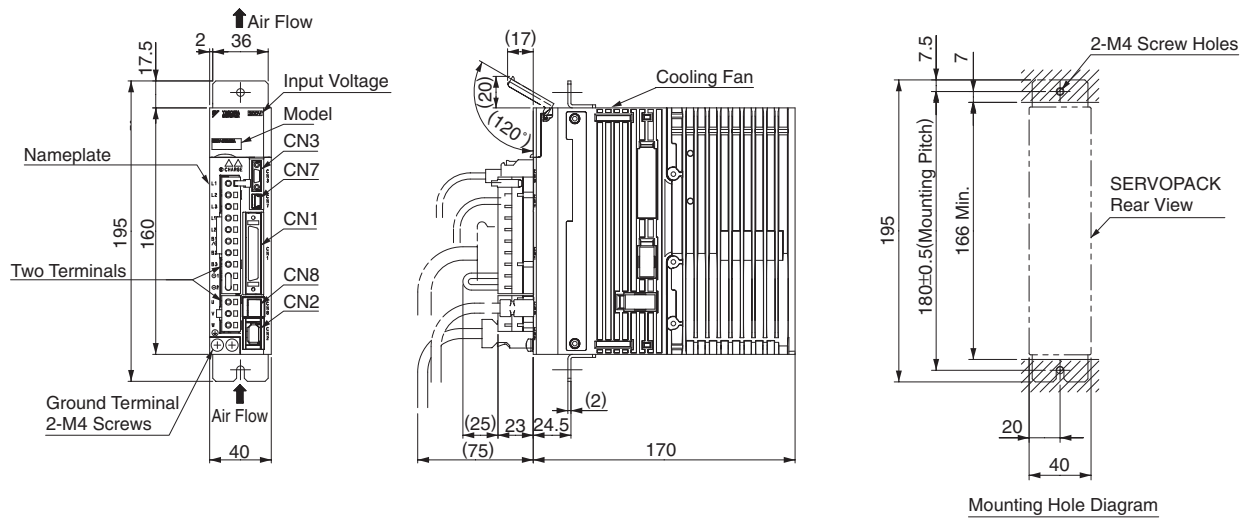

Mounting Hole Diagram

Approx. Mass: 1.0 kg

(3) Three-phase 200 VAC, Model: SGDV-3R8A0□A001 and -5R5A0□A001

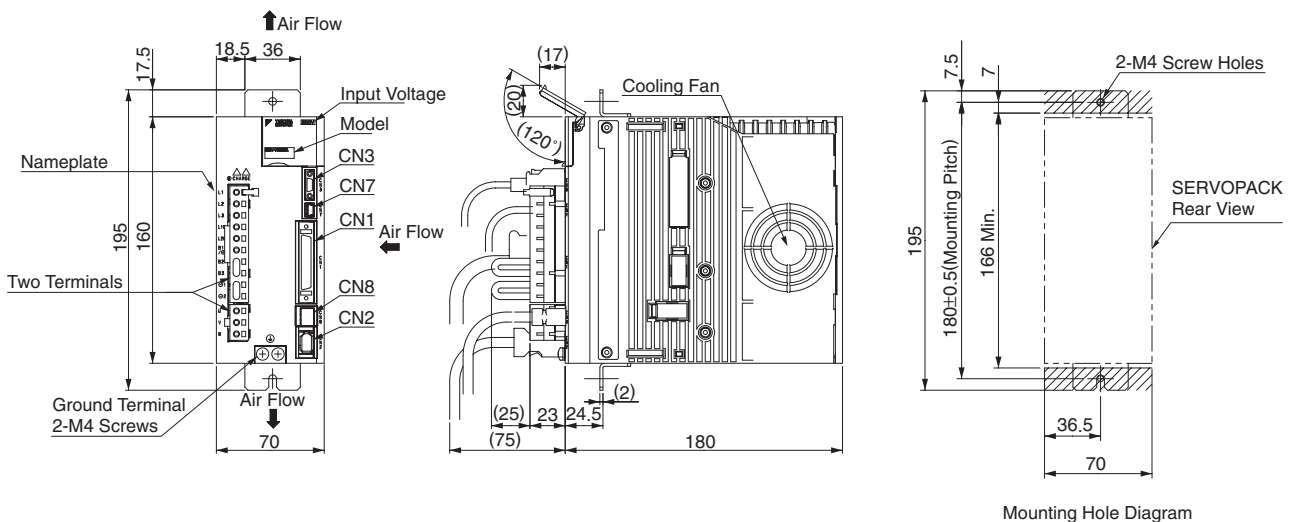

Mounting Hole Diagram

Approx. Mass: 1.5 kg

External Dimensions Units: mm

(4) Three-phase 400 VAC, Model: SGDV-1R9D0□A001, -3R5D0□A001, and -5R4D0□A001

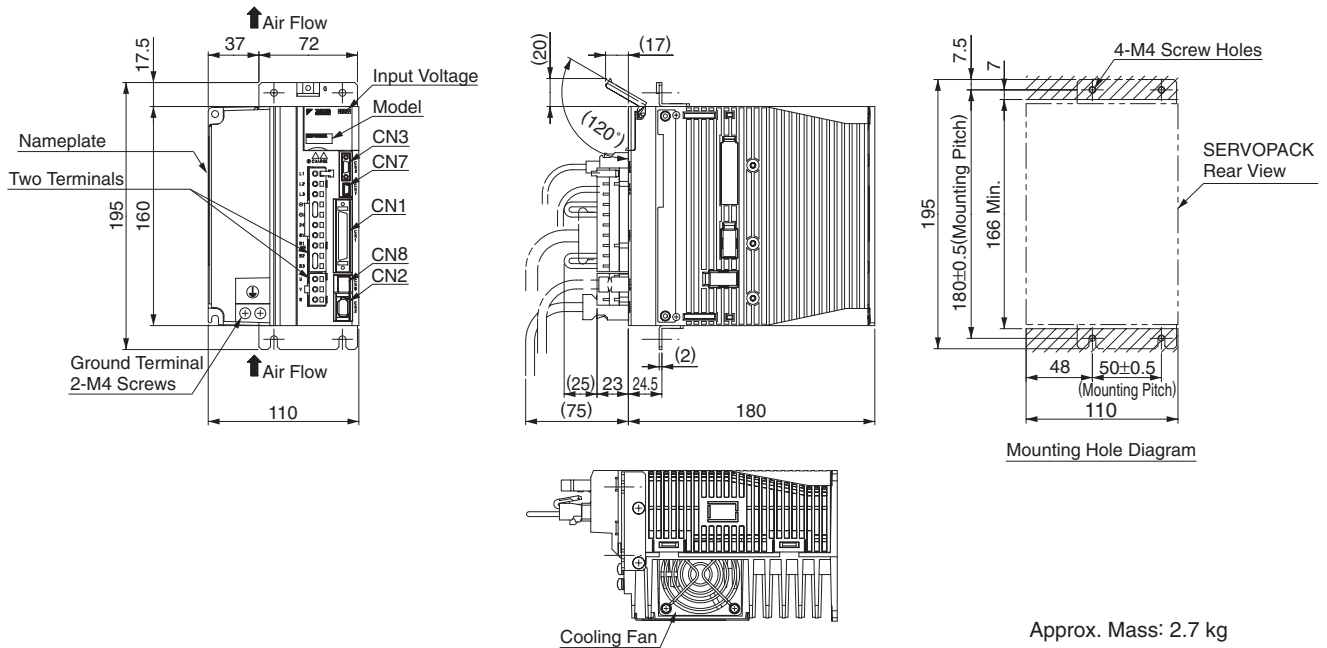

Approx. Mass: 2.7 kg

(5) Three-phase 400 VAC, Model: SGDV-8R4D0□A001 and -120D0□A001

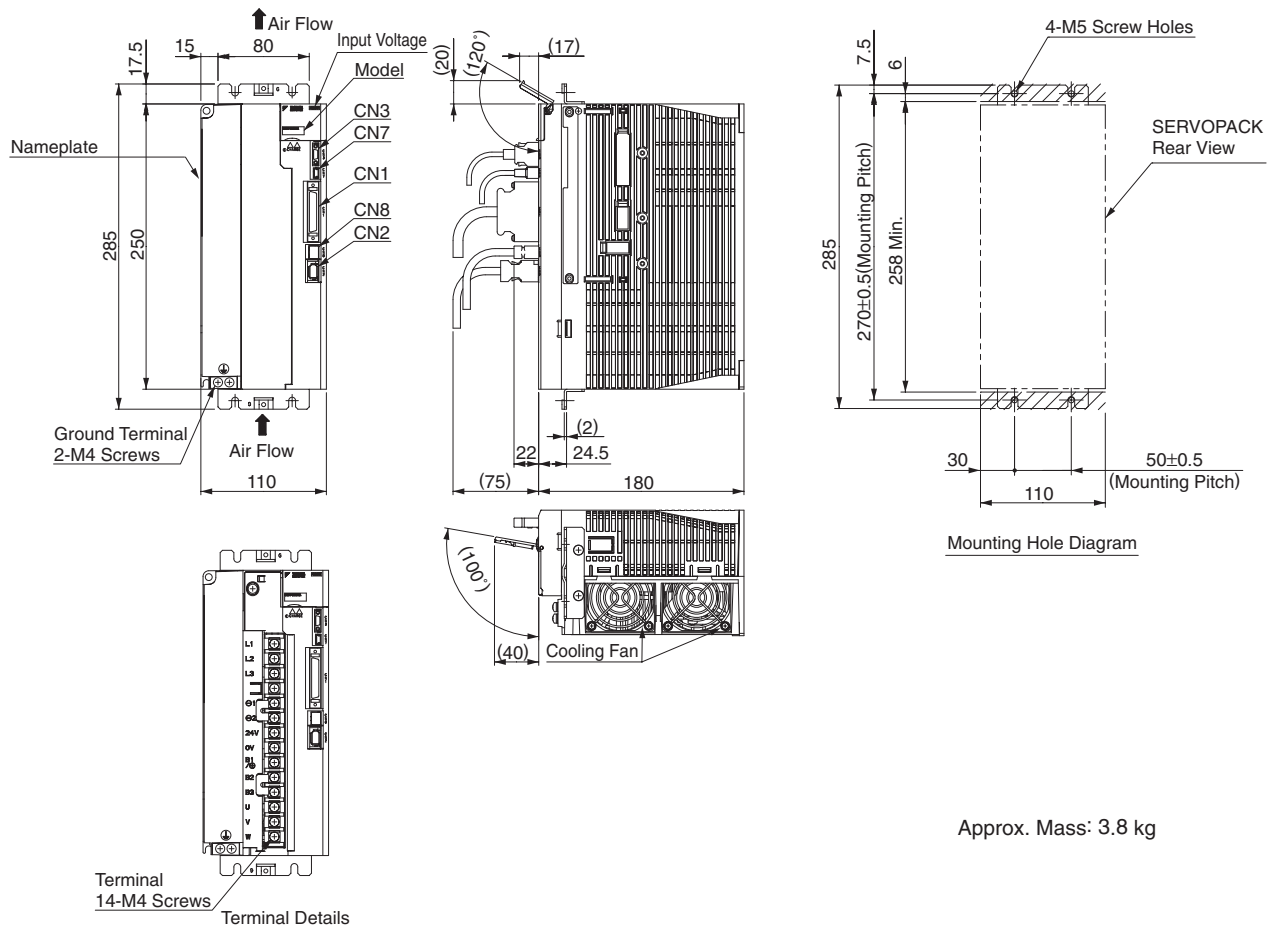

Approx. Mass: 3.8 kg

External Dimensions Units: mm

(6) Three-phase 400 VAC, Model: SGDV-170D0□A001

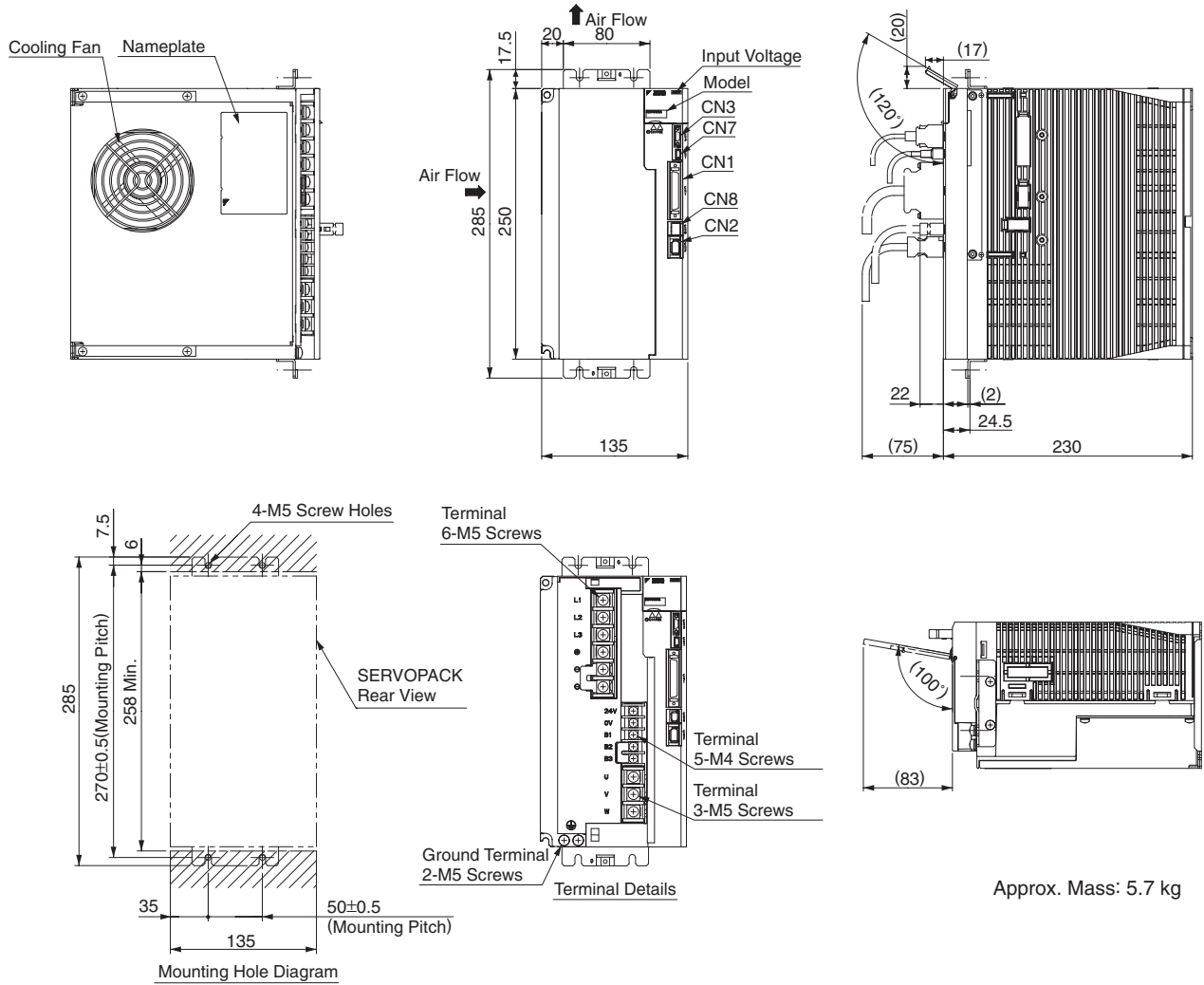

Approx. Mass: 5.7 kg

Connectors for Rack-mounted SERVOPACKs





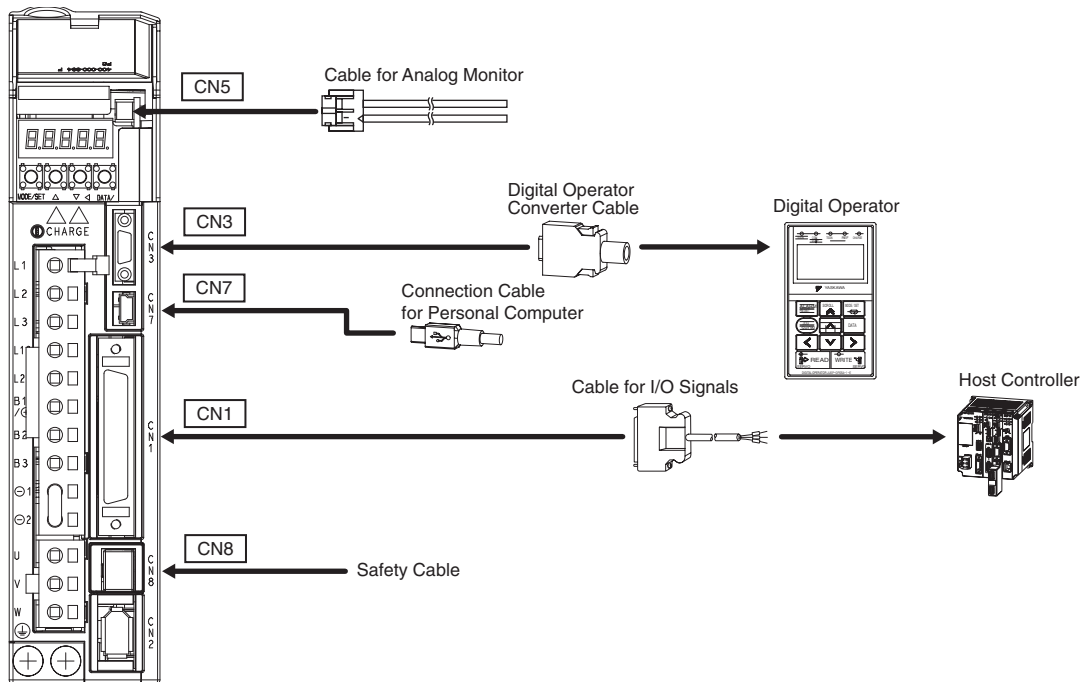

Port	Model	Pin	Manufacturer
CN1	10250-52A2PL	50	Sumitomo 3M Ltd.
CN2	53984-0671	6	Molex Japan Co., Ltd.
CN3	HDR-EC14LFDTN-SLE-PLUS	14	Honda Tsushin Kogyo Co., Ltd.
CN7	MNC23-5K5H00	5	ADVANCED-CONNECTEK INC.
CN8	1981080-1	8	Tyco Electronics AMP K.K.

Note: The connectors above or their equivalents are used for SERVOPACKs.

Selecting Cables

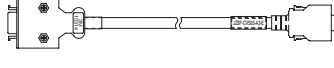
● Cables for **CN1** **CN3** **CN5** **CN7** **CN8** (Analog Voltage/Pulse Train Reference Type SERVOPACKs)



Name	Length	Order No.	Specifications	Details	
CN1 Cables for I/O Signals	Connector Terminal Converter Unit		JZSP-TA50PG-E	Terminal Block and 0.5 m Connection Cable 	(1)
	Cables with Loose Wires at One End	1 m	JZSP-CSI01-1-E	Cable with Loose Wires at Peripheral Devices 	(2)
		2 m	JZSP-CSI01-2-E		
CN3	Digital Operator		JZSP-OP05A-1-E	With Connection Cable (1 m) 	(3)
	Digital Operator Converter Cable*1		JZSP-CVS05-A3-E	Cable with Connectors at Both Ends (0.3 m) 	(4)
CN7	Connection Cables for Personal Computer		JZSP-CVS06-02-E		-
CN5 Cables for Analog Monitor	1 m	JZSP-CA01-E	SERVOPACK End 	(5)	
CN8 Cables for Safety Functions	Cables with Loose Wires at One End*2		JZSP-CVH03-03-E		-

*1 : A converter cable is required to use Σ -III series digital operators (model: JZSP-OP05A) for Σ -V series SERVOPACKs.

*2 : When using the safety function, connect this cable to the safety devices.

Even when not using the safety function, use SERVOPACKs with the Safe Jumper Connector (model: JZSP-CVH05-E) connected.

Selecting Cables

(1) Connector Terminal Converter Unit for CN1

· Configurations

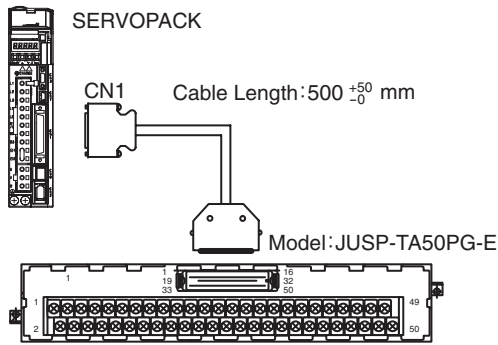

Model	Cable Length (L)
JUSP-TA50PG-E	0.5 m
JUSP-TA50PG-1-E	1 m
JUSP-TA50PG-2-E	2 m

· Dimensional Drawings of Terminal Block (Units: mm)

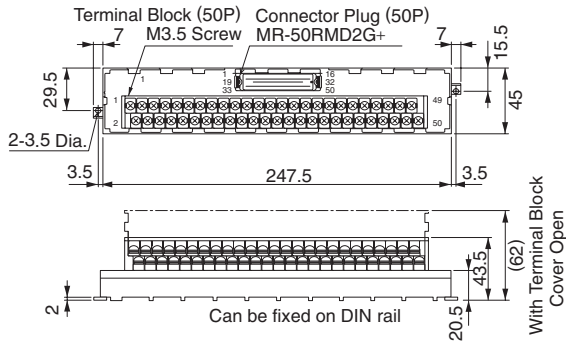

· Dimensional Drawings of Cable

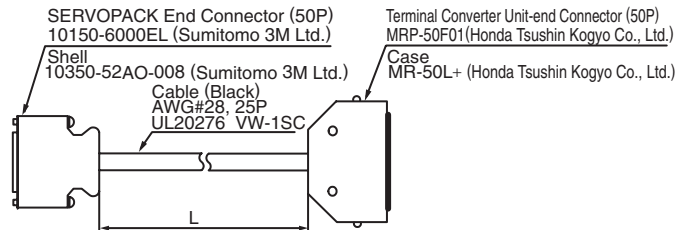

(2) Cable with Loose Wires at One End for CN1

· Dimensional Drawings of Cable

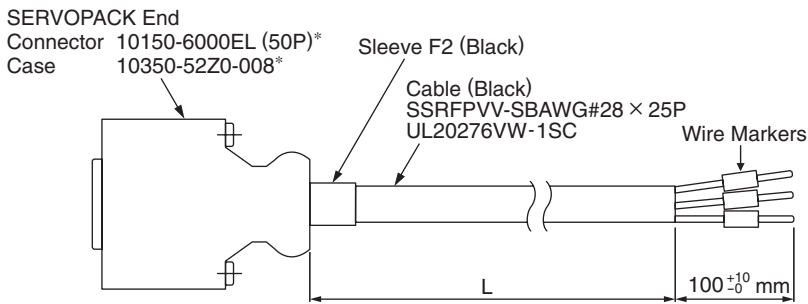

* : Manufactured by Sumitomo 3M Ltd.

Note : See the next page for the connection diagram.

Model	Cable Length (L)
JZSP-CSI01-1-E	1 m
JZSP-CSI01-2-E	2 m
JZSP-CSI01-3-E	3 m

Selecting Cables Units: mm

● Cable with Loose Wires at One End for CN1

Connection Diagram of JZSP-CSI01-□-E Cable

Pin No.	Signal	Wire Color	Marking		Lead Marker
			Color	Dots	
1	SG	Orange	Red	1	1
3	-	Orange	Black	1	3
2	SG	Gray	Red	1	2
4	SEN	Gray	Black	1	4
5	V-REF	White	Red	1	5
6	SG	White	Black	1	6
7	PULS	Yellow	Red	1	7
8	/PULS	Yellow	Black	1	8
9	T-REF	Pink	Red	1	9
10	SG	Pink	Black	1	10
11	SIGN	Orange	Red	2	11
12	/SIGN	Orange	Black	2	12
13	-	Gray	Red	2	13
14	/CLR	White	Red	2	14
15	CLR	White	Black	2	15
16	-	Gray	Black	2	16
17	-	Yellow	Red	2	17
18	-	Yellow	Black	2	18
19	PCO	Pink	Red	2	19
20	/PCO	Pink	Black	2	20
21	BAT(+)	Orange	Red	3	21
22	BAT(-)	Orange	Black	3	22
23	-	Gray	Red	3	23
24	-	Gray	Black	3	24
25	/V-CMP+	White	Red	3	25
26	/V-CMP-	White	Black	3	26
27	/TGON+	Yellow	Red	3	27
28	/TGON-	Yellow	Black	3	28
29	/S-RDY+	Pink	Red	3	29
30	/S-RDY-	Pink	Black	3	30
31	ALM+	Orange	Red	4	31
32	ALM-	Orange	Black	4	32
33	PAO	Gray	Red	4	33
34	/PAO	Gray	Black	4	34
35	PBO	White	Red	4	35
36	/PBO	White	Black	4	36
37	ALO1	Yellow	Red	4	37
38	ALO2	Yellow	Black	4	38
39	ALO3	Pink	Red	4	39
40	/S-ON	Pink	Black	4	40
41	/P-CON	Orange	Red	5	41
42	P-OT	Orange	Black	5	42
43	N-OT	Gray	Red	5	43
44	/ALM-RST	Gray	Black	5	44
45	/P-CL	White	Red	5	45
46	/N-CL	White	Black	5	46
47	+24V-IN	Yellow	Red	5	47
48	-	Pink	Red	5	48
49	-	Pink	Black	5	49
50	-	Yellow	Black	5	50
Case	Shield				

⚡: Represents twisted-pair wires.

● Connector Kit for CN1

Use the following connector and cable to assemble the cable. The CN1 connector kit includes one case and one connector.

Connector Kit Model	Case		Connector	
	Model	Qty	Model	Qty
JZSP-CSI9-1-E	10350-52Z0-008*	1 set	10150-3000PE* (Soldered)	1

* : Manufactured by Sumitomo 3M Ltd.

· Dimensional Drawings of Case

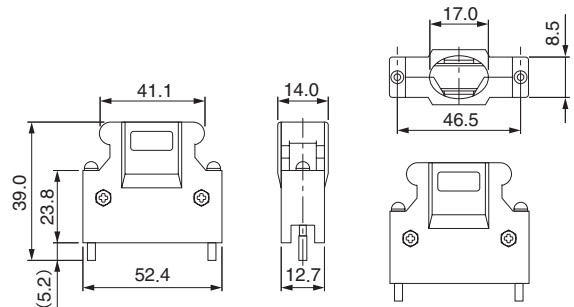

· Dimensional Drawings of Connector

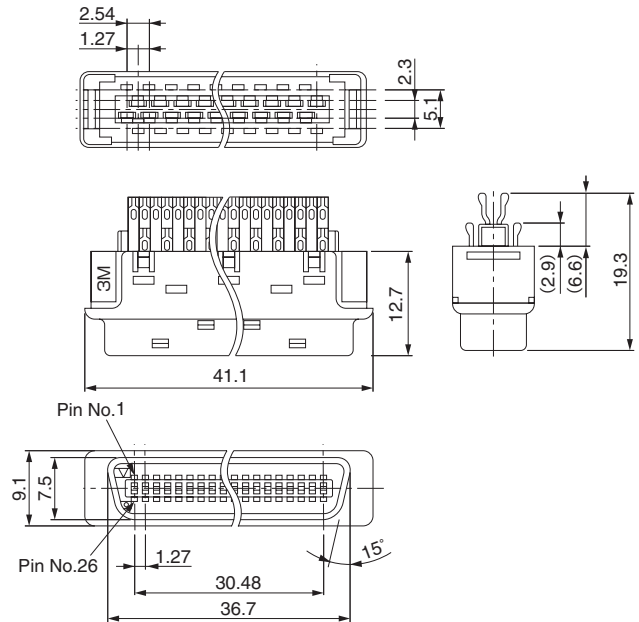

· Cable Size

Item	Specifications
Cable	Use twisted-pair or twisted-pair shielded wire.
Applicable Wires	AWG24, 26, 28, 30
Cable Finished Diameter	16 dia. max.

Selecting Cables Units: mm

(3) Digital Operator (Model: JUSP-OP05A-1-E)

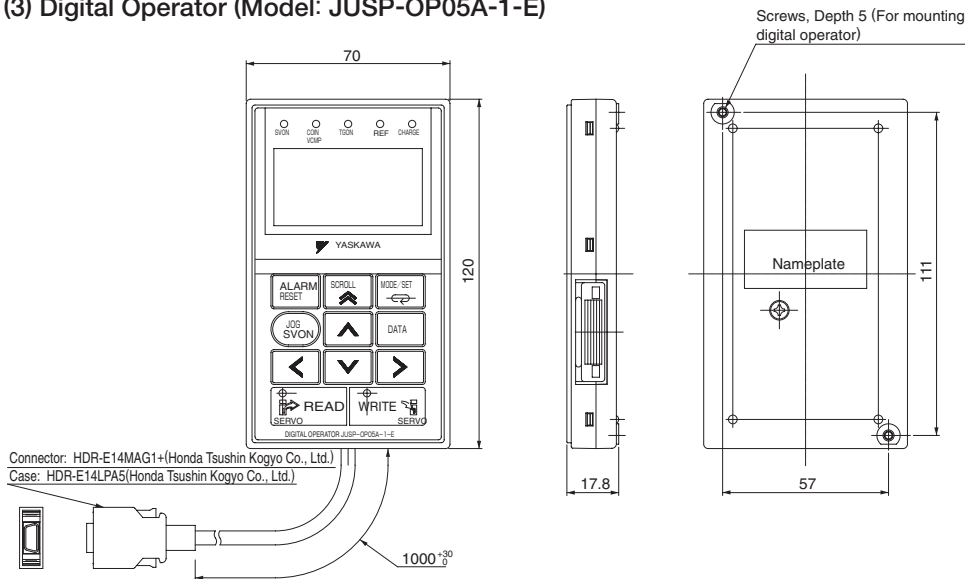

(4) Digital Operator Converter Cable for CN3 (Model: JZSP-CVS05-A3-E)

A converter cable is required to use Σ -III series digital operators (model: JUSP-OP05A) for Σ -V series SERVOPACKs.

• Dimensional Drawings

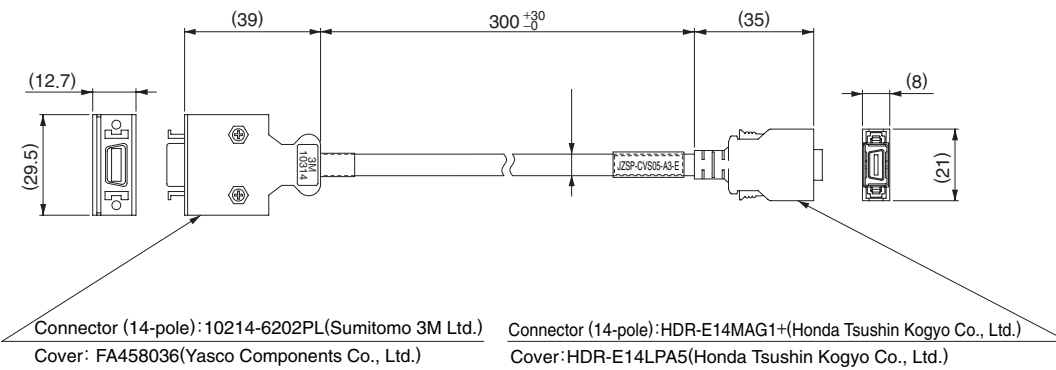

(5) Cable for Analog Monitor for CN5

• Dimensional Drawings

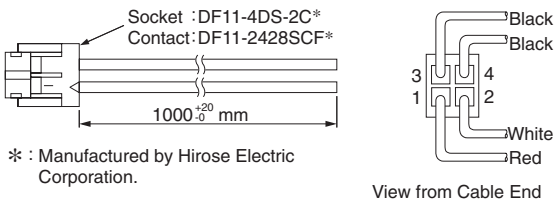

• Specifications

Pin No.	Cable Color	Signal	Standard Settings
1	Red	Analog Monitor 2	Motor speed : 1V/1000 min ⁻¹
2	White	Analog Monitor 1	Torque reference : 1V/100% rated torque
3, 4	Black (2 cables)	GND(0V)	—

Note : The specifications above are factory settings. Monitor specifications can be changed by changing parameters Pn006 and Pn007.

Serial Converter Units for Fully-closed Loop Control

● System Configuration for Fully-closed Loop Control

A fully-closed option card is required for fully-closed loop control of rotary servomotors. Contact your Yaskawa representatives for more details.

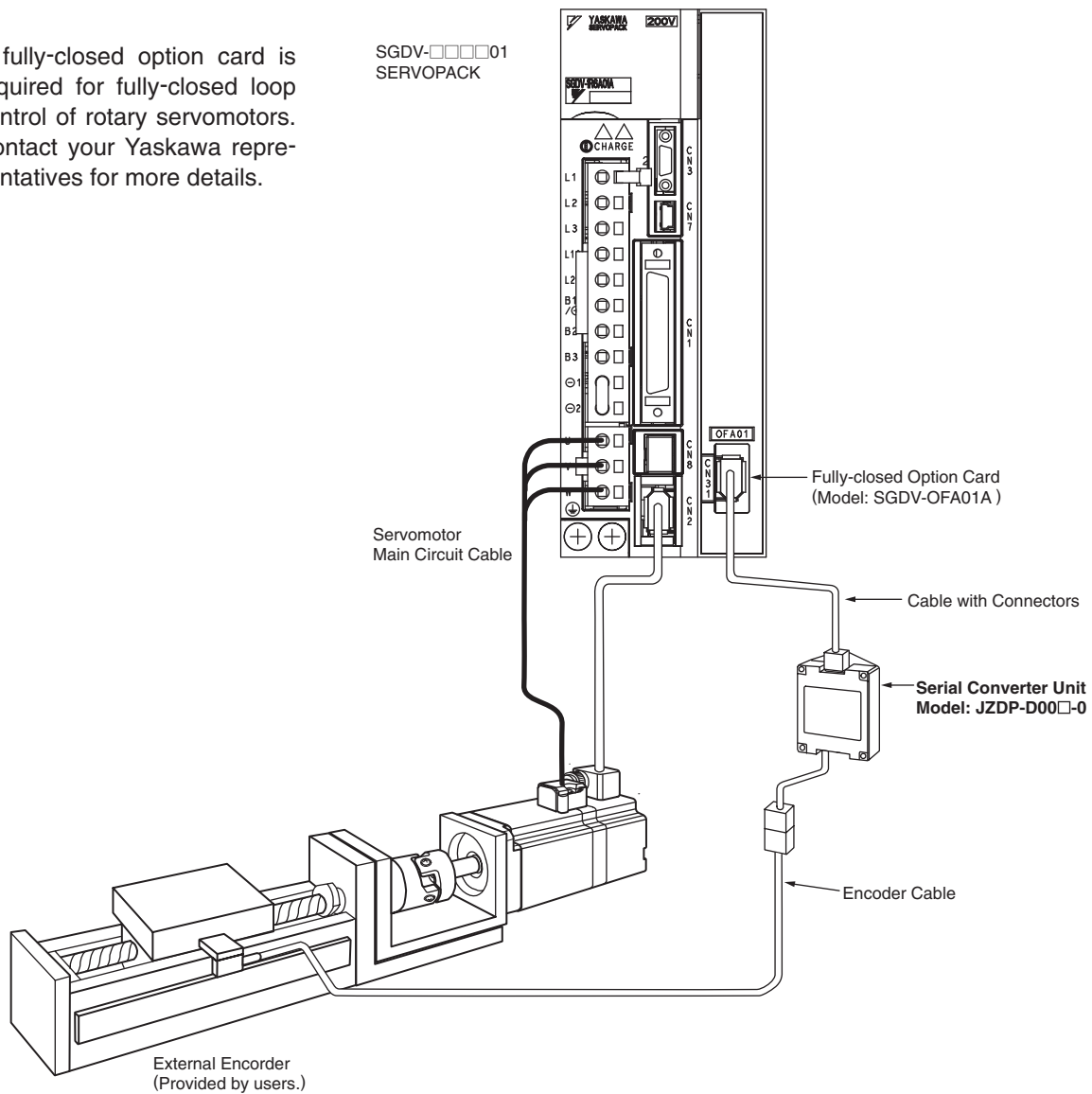

● Model Designations

JZDP - D00□ - 000 - E

Serial Converter Unit Model			
Code	Appearance	Applicable External Encoder	Hall Sensor
D003		Manufactured by HEIDENHAIN Corporation	None
D005		Manufactured by Renishaw plc.	None

Note: Using the serial converter unit JZDP-A□□□ with SGDV SERVOPACK will void our guarantee.

Serial Converter Units for Fully-closed Loop Control

● Characteristics and Specifications

Items	Specifications	
Electrical Characteristics	Power Supply Voltage	+5.0 V \pm 5%, ripple content 5% max.
	Current Consumption*1	120 mA typ. 350 mA max.
	Signal Resolution	Input two-phase sine wave: 1/256 pitch
	Max. Response Frequency	250 kHz
	Analog Input Signals*2 (cos, sin, Ref)	Differential input amplitude: 0.4 to 1.2 V Input signal level: 1.5 to 3.5 V
	Output Signal*3	Position data, alarms
	Output Method	Serial data communications [HDLC (High-level Data Link Control) protocol format with Manchester codes]
	Transmission Cycle	62.5 μ s
	Output Circuit	Balanced type transceiver (SN75LBC176 or the equivalent), internal terminating resistor: 120 Ω
Mechanical Characteristics	Approx. Mass	150 g
	Vibration Resistance	98 m/s ² max. (10 to 2500 Hz) in three directions
	Impact Resistance	980 m/s ² , (11 ms) two times in three directions
Environmental Conditions	Operating Temperature	0 to 55°C
	Storage Temperature	-20 to +80°C
	Humidity	20% to 90%RH (no condensation)

*1: The current consumption of the external encoder is not included in this value.

The current consumption of the external encoder must be taken into consideration for the current capacity of host controller that supplies the power.

*2: Input a value within the specified range. Otherwise, incorrect position information is output, and the device may be damaged.

*3: The transmission is enabled 100 to 300 ms after the power turns on.

● Analog Signal Input Timing

The following figure shows the input timing of the analog signals.

When the cos and sin signals are shifted 180 degrees, the differential signals are the /cos and /sin signals.

The specifications of the cos, /cos, sin, and /sin signals are identical except for the phase.

Input the signals Ref and /Ref so that they shall cross each other as shown in the figure because they are input into the converter. When they are crossed, the output data will be counted up.

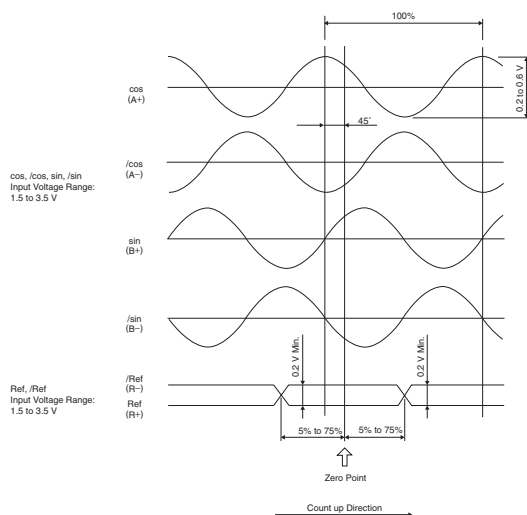

IMPORTANT

■ Precautions

- 1 Never perform insulation resistance and withstand voltage tests.
- 2 When analog signals are input to the serial converter unit, noise influence on the analog signals affects the unit's ability to output correct position information. The analog cable must be as short as possible and shielded.
- 3 Do not connect or disconnect the unit while power is being supplied, or the unit may be damaged.
- 4 When using multiple axes, use a shield cable for each axis. Do not use a shield cable for multiple axes.

Serial Converter Units for Fully-closed Loop Control Units: mm

External Dimensions

(1) Model: JZDP-D003-□□□-E

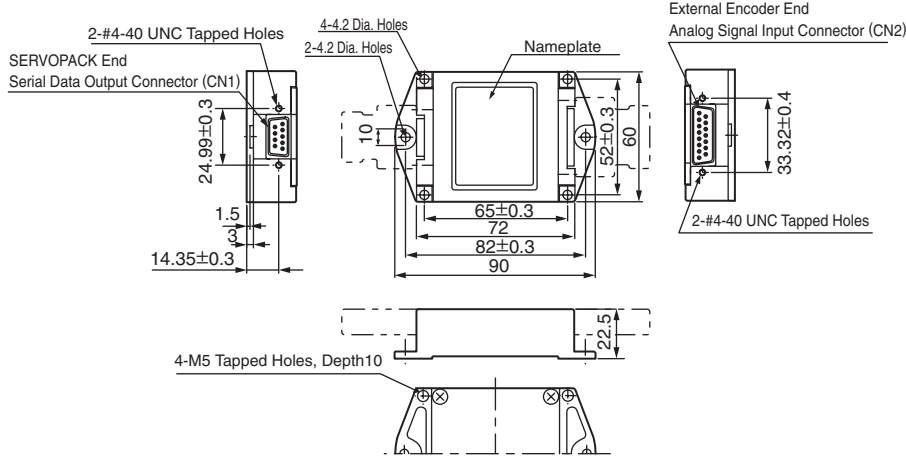

(2) Model: JZDP-D005-□□□-E

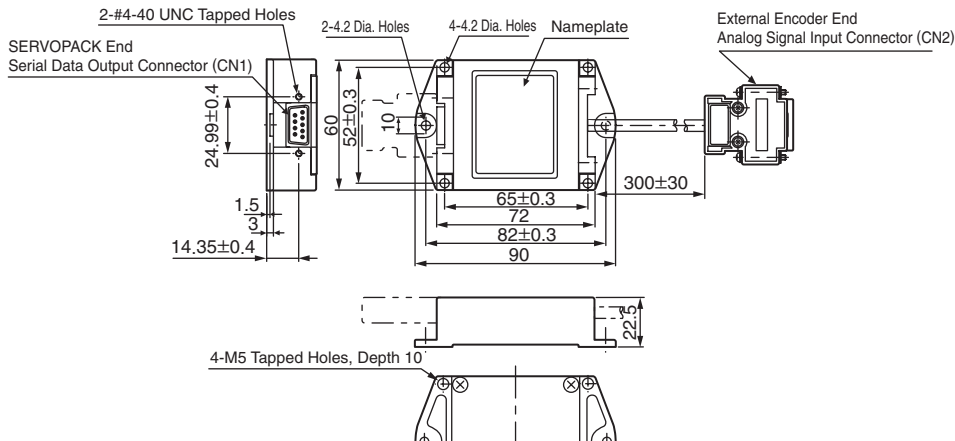

Connection Cables

Recommended Cables

Name	Application	Model	Length
Cables with Connectors at Both Ends	Connection between SERVOPACK (Fully-closed option card) connector CN31 and serial converter unit	JZSP-CLP70-03-E	3 m
		JZSP-CLP70-05-E	5 m
		JZSP-CLP70-10-E	10 m
		JZSP-CLP70-15-E	15 m
		JZSP-CLP70-20-E	20 m

Dimensional Drawing

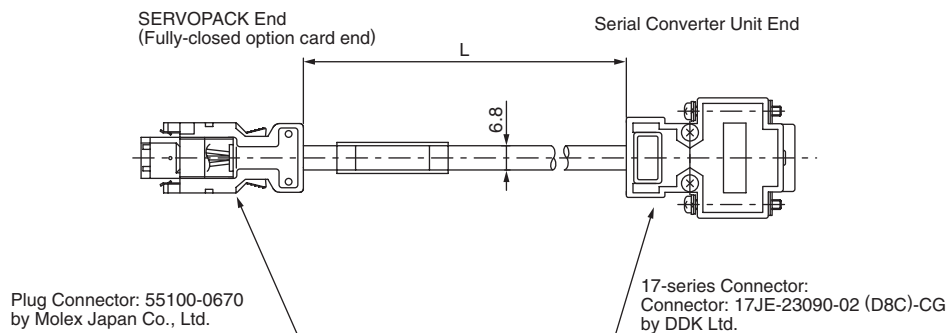

Serial Converter Units for Fully-closed Loop Control Units: mm

● **Connection Examples**

(1) Connection Example with External Encoder by HEIDENHAIN Corporation
 · Model: JZDP-D003-□□□□-E

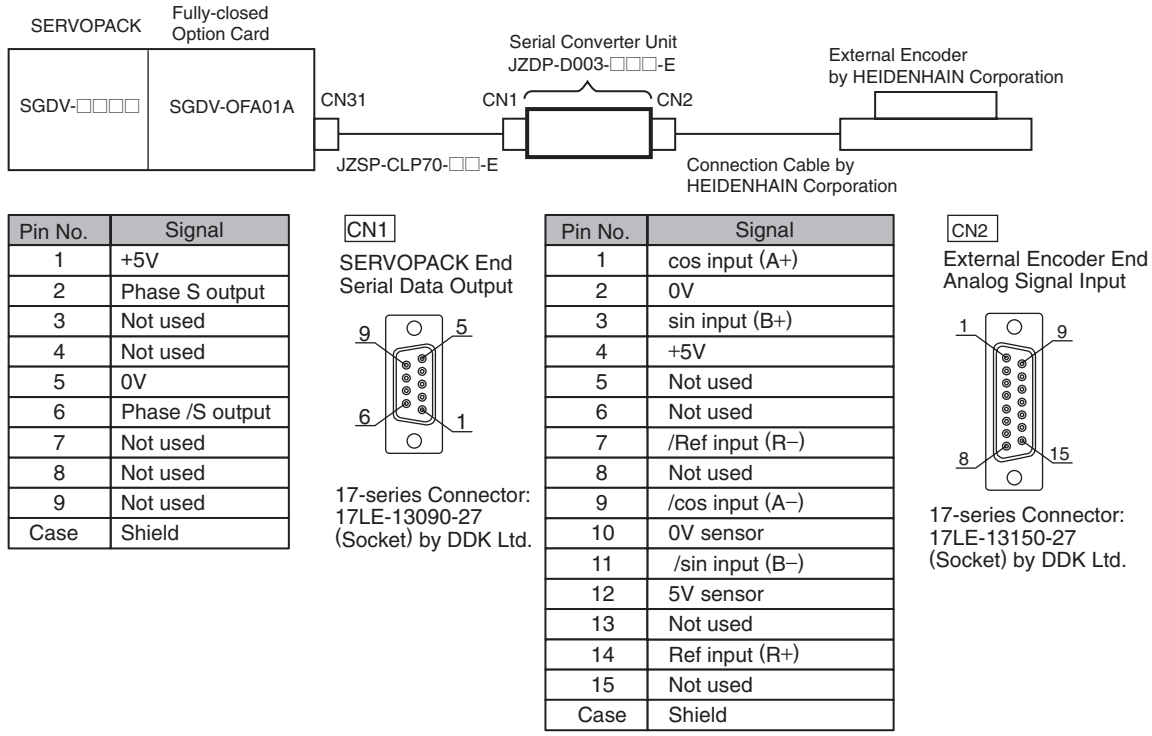

Notes: 1 Do not use the unused pins.
 2 The external encoder (analog 1 Vp-p output, D-sub 15-pin) by HEIDENHAIN Corporation can be directly connected.

(2) Connection Example with External Encoder by Renishaw plc.
 · Model : JZDP-D005-□□□□-E

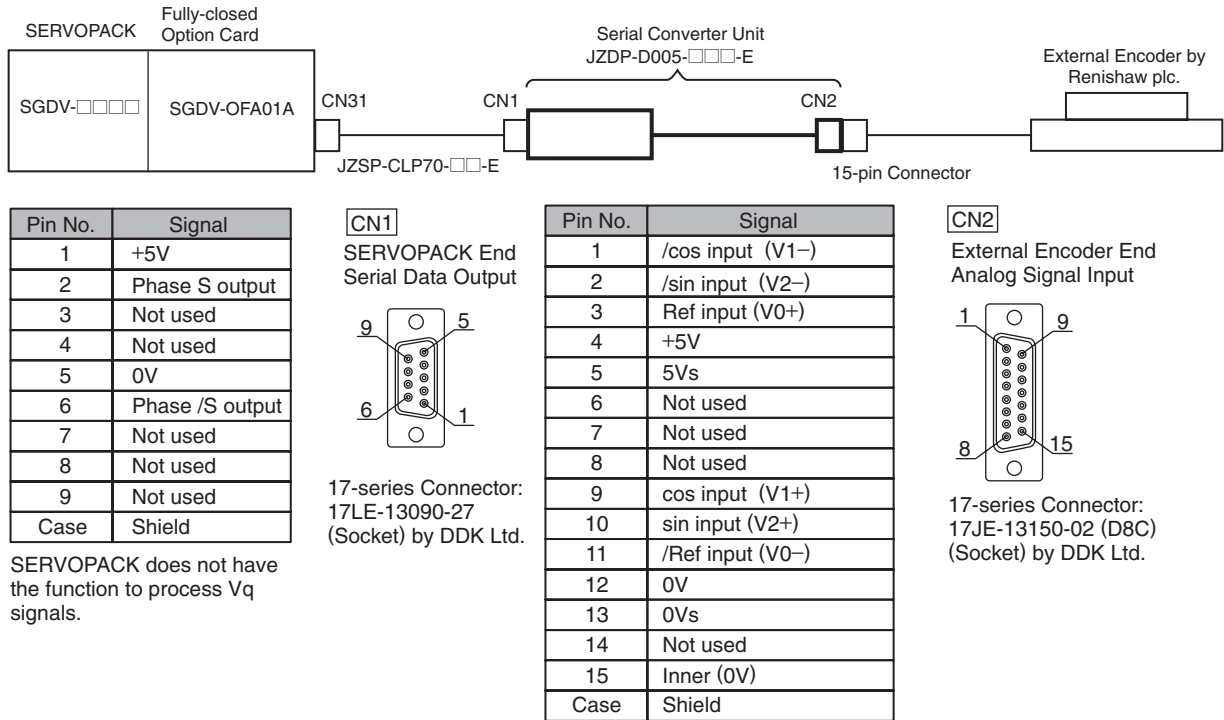

SERVOPACK does not have the function to process Vq signals.

Notes: 1 Do not use the unused pins.
 2 The external encoder (analog 1 Vp-p output, D-sub 15-pin) by Renishaw plc. can be directly connected. However, the BID and DIR signals are not connected.
 3 Use the external encoder-end connector to change the home position specifications of the external encoder.

Serial Converter Units for Fully-closed Loop Control

- (3) Connection Example with External Encoder by Mitutoyo Corporation (Model: ABS ST78□A)
When using this external encoders, serial converter units are not required.

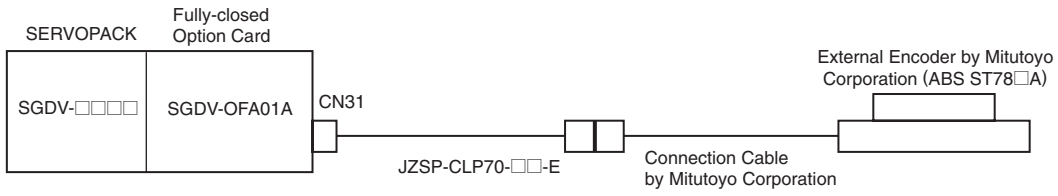

MECHATROLINK-II Communications Reference Type SERVOPACKs

SGDV-□□□□11
(For Rotary Servomotors)

SGDV-□□□□15
(For Linear Servomotors)



Model Designations

SGDV - R70 A 11 A □

Σ-V Series
SGDV SERVOPACK

Current

Voltage	Code	Applicable Servomotor Max. Capacity kW
200 V	R70	0.05
	R90	0.1
	1R6	0.2
	2R8	0.4
	3R8	0.5
	5R5	0.75
400 V	1R9	0.5
	3R5	1.0
	5R4	1.5
	8R4	2.0
	120	3.0
	170	5.0

Options

Code	Specifications
Blank	Base-mounted (standard)
001000	Rack-mounted (optional)

Design Revision Order
A, B...

Interface

Code	Specifications
11	MECHATROLINK-II communications Reference Type (for rotary servomotors)
15	MECHATROLINK-II communications Reference Type (for linear servomotors)

Voltage

Code	Specifications
A	200 VAC
D	400 VAC

Features

- **Real-time communications**

MECHATROLINK-II communications enable high-speed control for 30 stations at a maximum transmission speed of 10 Mbps in a transmission cycle from 250 μ s to 4 ms (user setting). Such a high transmission speed allows real-time transmission of various data required for control.

- **Cost savings**

Thirty stations can be connected to a single MECHATROLINK-II transmission line, so wiring costs and time are greatly reduced. Also, only one signal connector is required on the host controller. And, the all-digital network eliminates the need for conversion from digital to analog for speed/torque references and for a pulse generator to generate position references.

- **High-precision motion control**

The SGDV SERVOPACK when connected to the host controller in the MECHATROLINK-II network provides not only torque, position, and speed control but also synchronized phase control that requires advanced control technology. The control mode can be changed online so that the machine can move smoothly in complex motions with great efficiency.

Ratings

SERVOPACK Model	SGDV-	R70A	R90A	1R6A	2R8A	3R8A	5R5A	1R9D	3R5D	5R4D	8R4D	120D	170D
Main Circuit		Three-phase 200 to 230 VAC+10% to -15% 50/60 Hz						Three-phase 380 to 480 VAC+10% to -15% 50/60 Hz					
Control Circuit		Single-phase 200 to 230 VAC+10% to -15% 50/60 Hz						24 VDC \pm 15%					
Applicable Servomotor Max. Capacity	kW	0.05	0.1	0.2	0.4	0.5	0.75	0.5	1	1.5	2	3	5
Continuous Output Current	Arms	0.66	0.91	1.6	2.8	3.8	5.5	1.9	3.5	5.4	8.4	11.9	16.5
Max. Output Current	Arms	2.1	2.9	6.5	9.3	11	16.9	5.5	8.5	14	20	28	42

Specifications

Items		Specifications	
Input Power Supply	Main Circuit	200 V	Three-phase 200 to 230 VAC +10% to -15% 50/60 Hz
		400 V *1	Three-phase 380 to 480 VAC +10% to -15% 50/60 Hz
	Control Circuit	200 V	Single-phase 200 to 230 VAC +10% to -15% 50/60 Hz
		400 V *1	24 VDC ±15%
Control Method		For 200 V, for 400 V, three-phase full-wave rectification IGBT PWM control, sine-wave driven	
Feedback		Serial encoder: 13-bit (incremental encoder) Serial encoder: 20-bit (incremental/absolute encoder) 4 Mb/s communications, 8 Mb/s communications	
Operating Conditions	Ambient/Storage Temperature		Ambient temperature: 0 to +55°C, storage temperature: -20 to +85°C
	Ambient/Storage Humidity		90%RH or less (no condensation)
	Vibration/Impact Resistance		Vibration resistance: 4.9 m/s ² , impact resistance: 19.8 m/s ²
	Protection class/Pollution degree		Protection class: IP 1X, pollution degree: 2 Do not use SERVOPACKs in the following locations: · Locations subject to corrosive or flammable gasses · Locations subject to exposure to water, oil, or chemicals · Locations subject to dust, including iron dust, and salts
	Others		Do not use SERVOPACKs in the following locations: · Locations subject to static electricity noise, strong electromagnetic/magnetic fields, radioactivity
Elevation		1000 m or less	
Compliant Standards		UL 508C EN50178, EN55011 class A group 1, EN61800-3, EN61800-5-1	
Configuration		Base-mounted (Rack mounting available as an option for some models.)	
Performance	Speed Control Range		1:5000 (The lowest speed of the speed control range is the speed at which the servomotor will not stop with a rated torque load.)
	Speed Regulation*2	Load Regulation	0% to 100% load: ±0.01% max. (at rated speed)
		Voltage Regulation	Rated voltage: ±10% : 0% (at rated speed)
		Temperature Regulation	25±25°C : ±0.1% max. (at rated speed)
	Torque Control Tolerance (Repeatability)		±1%
Soft Start Time Setting		0 to 10 s (can be set individually for acceleration and deceleration.)	
I/O Signals	Encoder Output Pulses		Phase A, phase B, phase C: line driver output The number of dividing pulse: Any setting ratio is available.
Communications	RS-422A Communications	Interface	Digital operator, RS-422A port of personal computers etc.
		1:N communications	RS-422A port: N= 15 max. available
		Axis address setting	Set by parameters
		Function	Status display, parameter settings, adjustment functions, utility functions
	USB Communications	Interface	Personal computers (application: SigmaWin+)
		1:N communications	Compliant with USB1.1 standard
Function		Status display, parameter settings, adjustment functions, utility functions	
Display	Power Charge		CHARGE for main circuit power supply input confirmation LED (red) 1 ch
Analog Monitor		Analog monitor connector built in for monitoring speed, torque and other reference signals. Number of channels: 2 ch	
Protective Functions		Overcurrent, Overvoltage, low voltage, overload, regeneration error	
Utility Functions		Alarm trace back, JOG operation, origin search, etc.	
Regenerative Processing		200 VAC SGDV-R70A, -R90A, -1R6A, -2R8A: External regenerative resistor (optional) 200 VAC SGDV-3R8A, -5R5A: Built-in regenerative resistor 400 VAC model: Built-in regenerative resistor	
Safety Functions	Input	/HWBB1, /HWBB2: Hard wire base block signal	
	Output	EDM1: Status monitor (fixed output) of built-in safety circuit	
Option Card Function	Feedback	Serial encoder communications input for fully-closed loop control	

*1: SGDV-□□□□15 SERVOPACK has no 400 V model.

*2: Speed regulation is defined as follows:

$$\text{Speed regulation} = \frac{\text{No-load motor speed} - \text{Total load motor speed}}{\text{Rated motor speed}} \times 100\%$$

The motor speed may change due to voltage variations or amplifier drift and changes in processing resistance due to temperature variation. The ratio of speed changes to the rated speed represent speed regulation due to voltage and temperature variations.

Specifications

● Rotary Servomotors

Items		Specifications	
I/O Signal	Sequence Input	Number of Channels	7 ch
		Function	Signal allocations and positive/negative logics can be modified. Homing deceleration switch signal (/DEC), external latch signal (/EXT1 to 3), forward run prohibited (P-OT), reverse run prohibited (N-OT), forward torque limit (/P-CL), reverse torque limit (/N-CL)
	Sequence Output	Number of Channels	3 ch
		Function	Signal allocations and positive/negative logics can be modified. Positioning completion (/COIN), speed coincidence detection (/V-CMP), servomotor rotation detection (/TGON), servo ready (/S-RDY), torque limit detection (/CLT), speed limit detection (/VLT), brake interlock (/BK), warning (/WARN), NEAR (/NEAR)
Panel Operator		Display	7-segment 1-digit LED (red)
		Switch	Rotary switch: 16 ch, DIP switch: 4 ch
MECHATROLINK Communications		Communications Protocol	MECHATROLINK-II
		Station Address	41H to 5FH (max. number of slaves: 30)
		Transmission Speed	10 Mbps, 4 Mbps
		Transmission Cycle	250 μ s, 0.5 to 4.0 ms (multiple of 0.5 ms)
Command Method		Performance	Position control, speed control, and torque control through MECHATROLINK-II communications
		Command Input	MECHATROLINK commands and MECHATROLINK-II commands (for sequence, motion, data setting/reference, monitor, adjustment, and other commands.)

● Linear Servomotors

Items		Specifications	
I/O Signal	Sequence Input	Number of Channels	7 ch
		Function	Signal allocations and positive/negative logics can be modified. Homing deceleration switch signal (/DEC), external latch signal (/EXT1 to 3), forward run prohibited (P-OT), reverse run prohibited (N-OT), forward force limit (/P-CL), reverse force limit (/N-CL)
	Sequence Output	Number of Channels	4 ch
		Function	Signal allocations and positive/negative logics can be modified. Positioning completion (/COIN), speed coincidence detection (/V-CMP), servomotor movement detection (/TGON), servo ready (/S-RDY), force limit detection (/CLT), speed limit detection (/VLT), brake interlock (/BK), warning (/WARN), NEAR (/NEAR)
Panel Operator		Display	7-segment 1-digit LED (red)
		Switch	Rotary switch: 16 ch, piano switch: 4 ch
MECHATROLINK Communications		Communications Protocol	MECHATROLINK-II
		Station Address	41H to 5FH (max. number of slaves: 30)
		Transmission Speed	10 Mbps, 4 Mbps
		Transmission Cycle	250 μ s, 0.5 to 4.0 ms (multiple of 0.5 ms)
Command Method		Performance	Position control, speed control, and force control through MECHATROLINK-II communications
		Command Input	MECHATROLINK commands and MECHATROLINK-II commands (for sequence, motion, data setting/reference, monitor, adjustment, and other commands.)

Power Supply Capacities and Power Losses

The following table shows SERVOPACK's power supply capacities and power losses at the rated output.

Main Circuit Power Supply	Applicable Servomotor Max. Capacity kW	SERVOPACK Model SGD V-	Power Supply Capacity kVA	Output Current A	Main Circuit Power Loss W	Regenerative Resistor Power Loss W	Control Circuit Power Loss W	Total Power Loss W
Three-phase 200 V	0.05	R70A	0.2	0.66	5.1	—	17	22.1
	0.1	R90A	0.3	0.91	7.3			24.3
	0.2	1R6A	0.6	1.6	13.5			30.5
	0.4	2R8A	1	2.8	24.0			41.0
	0.5	3R8A	1.4	3.8	20.1	8	45.1	
	0.75	5R5A	1.6	5.5	43.8		68.8	
Three-phase 400 V	0.5	1R9D	1.1	1.9	24.6	14	21	59.6
	1.0	3R5D	2.3	3.5	46.1			81.1
	1.5	5R4D	3.5	5.4	71.3			106.3
	2.0	8R4D	4.5	8.4	77.9	28	25	130.9
	3.0	120D	7.1	11.9	108.7			161.7
	5.0	170D	11.7	16.5	161.1			221.1

Notes: 1 SGD V-R70A, -R90A, -1R6A, and -2R8A SERVOPACKs do not have built-in regenerative resistors. If the regenerative energy exceeds the specified value, connect an external regenerative resistor.

2 Regenerative resistor power losses are allowable losses. Take the following action if this value is exceeded.

·Remove the lead from the internal regenerative resistor in the SERVOPACK (SGDV-3R8A, -5R5A, and 400-V SERVOPACKs).

·Install an external regenerative resistor.

3 External regenerative resistors are options.

External Dimensions Units: mm

● **Base-mounted SERVOPACKs**

(1) Three-phase 200 VAC, model: SGDV-R70A1□A, -R90A1□A, and -1R6A1□A

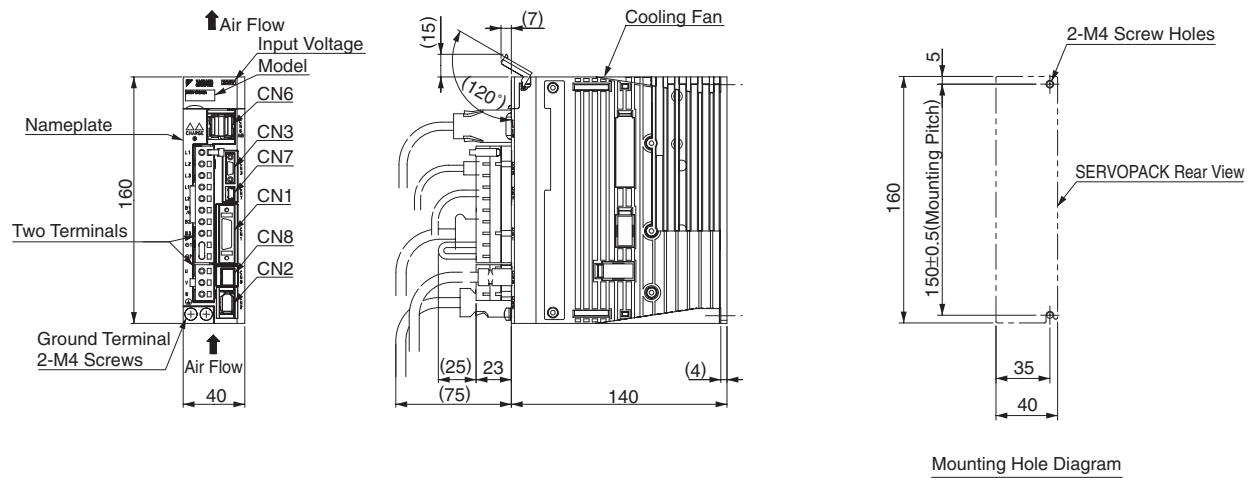

(2) Three-phase 200 VAC, model: SGDV-2R8A1□A

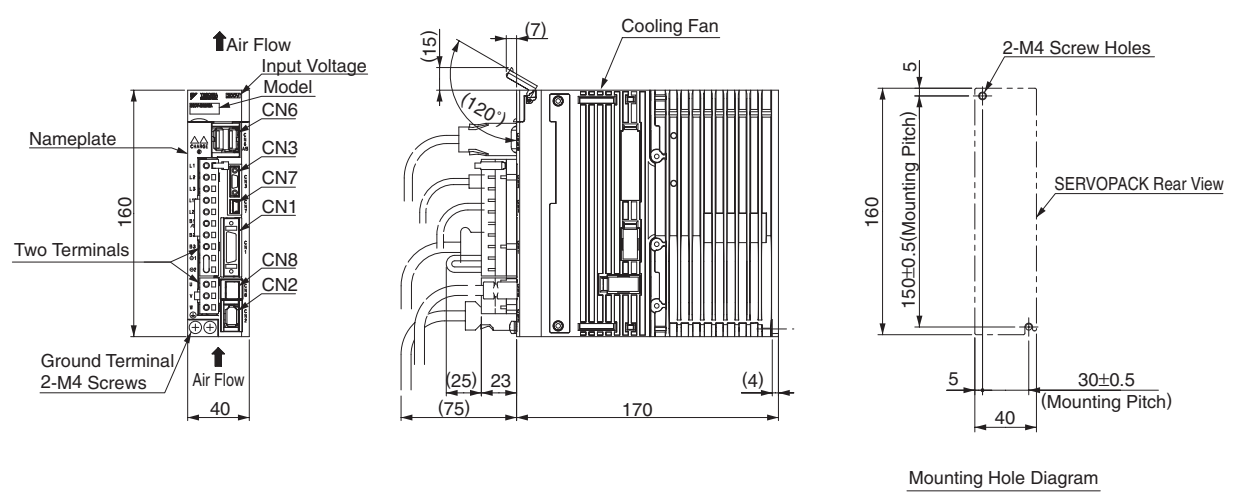

(3) Three-phase 200 VAC, model: SGDV-3R8A1□A and -5R5A1□A

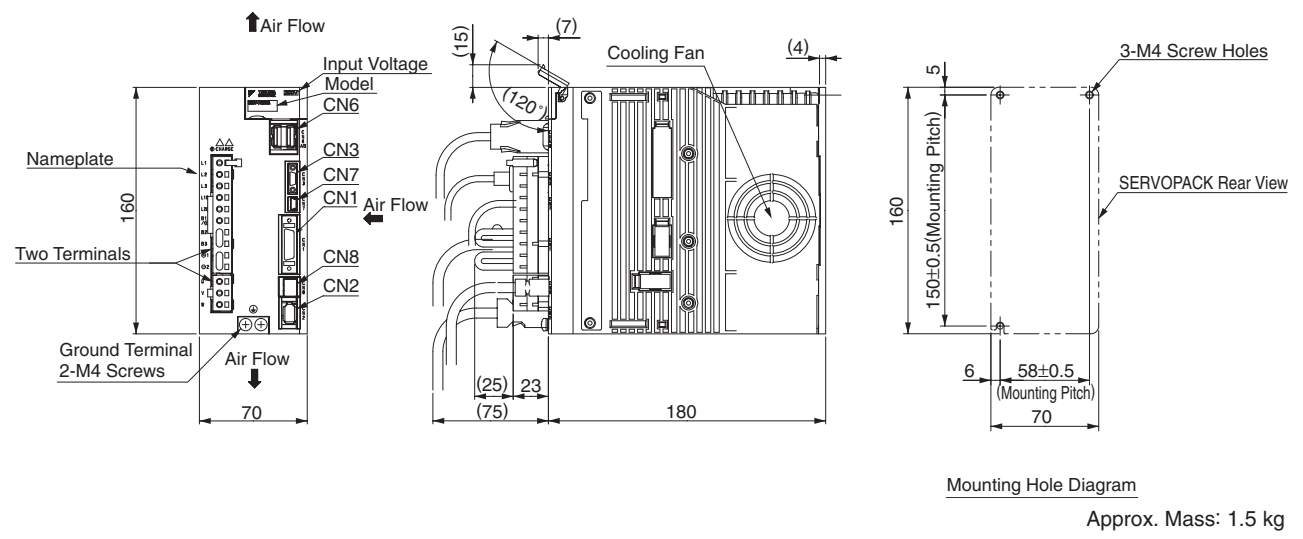

M-II Type SERVOPACKs

External Dimensions Units: mm

(4) Three-phase 400 VAC, model: SGDV-1R9D1□A, -3R5D1□A, and -5R4D1□A

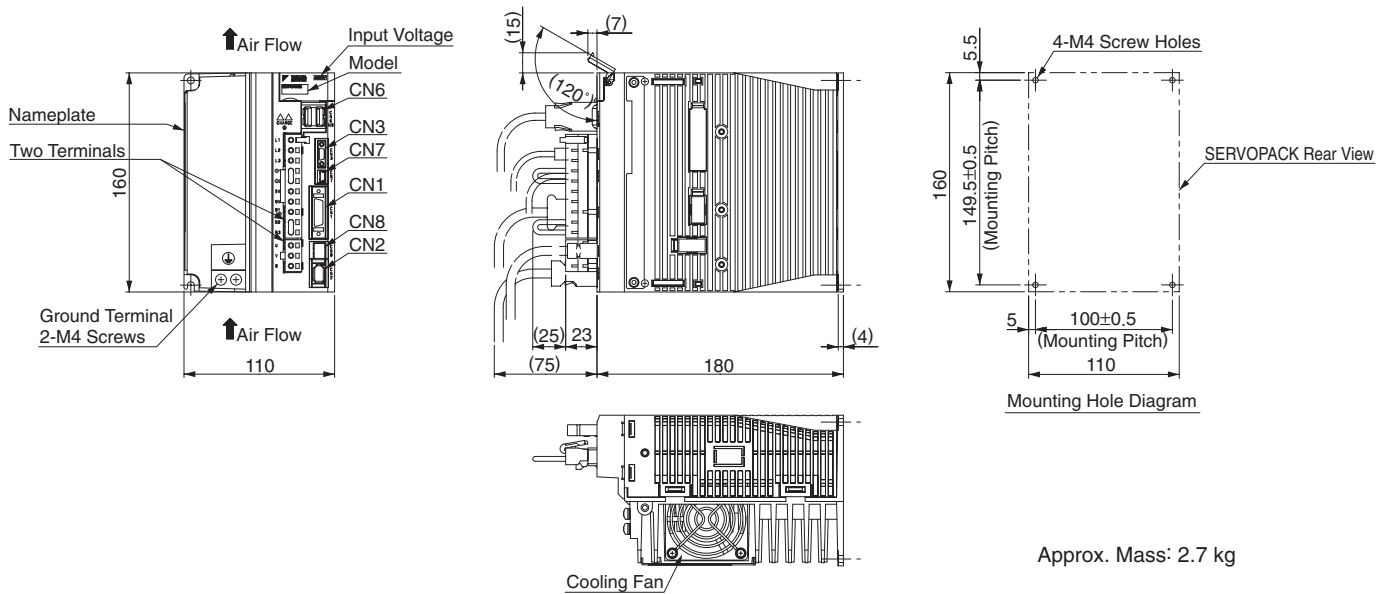

(5) Three-phase 400 VAC, model: SGDV-8R4D1□A and -120D1□A

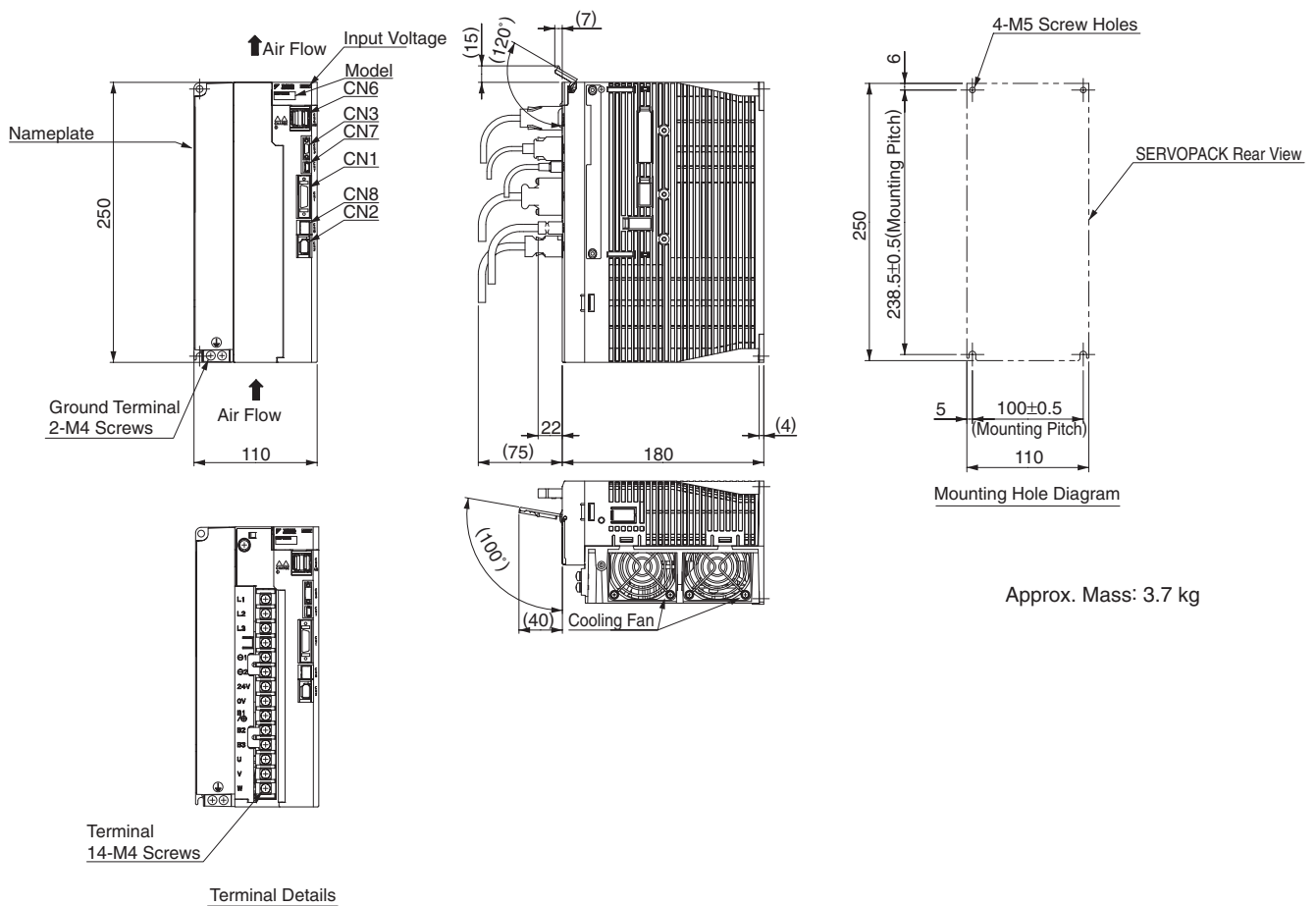

External Dimensions Units: mm

(6) Three-phase 400 VAC, model: SGDV-170D1□A

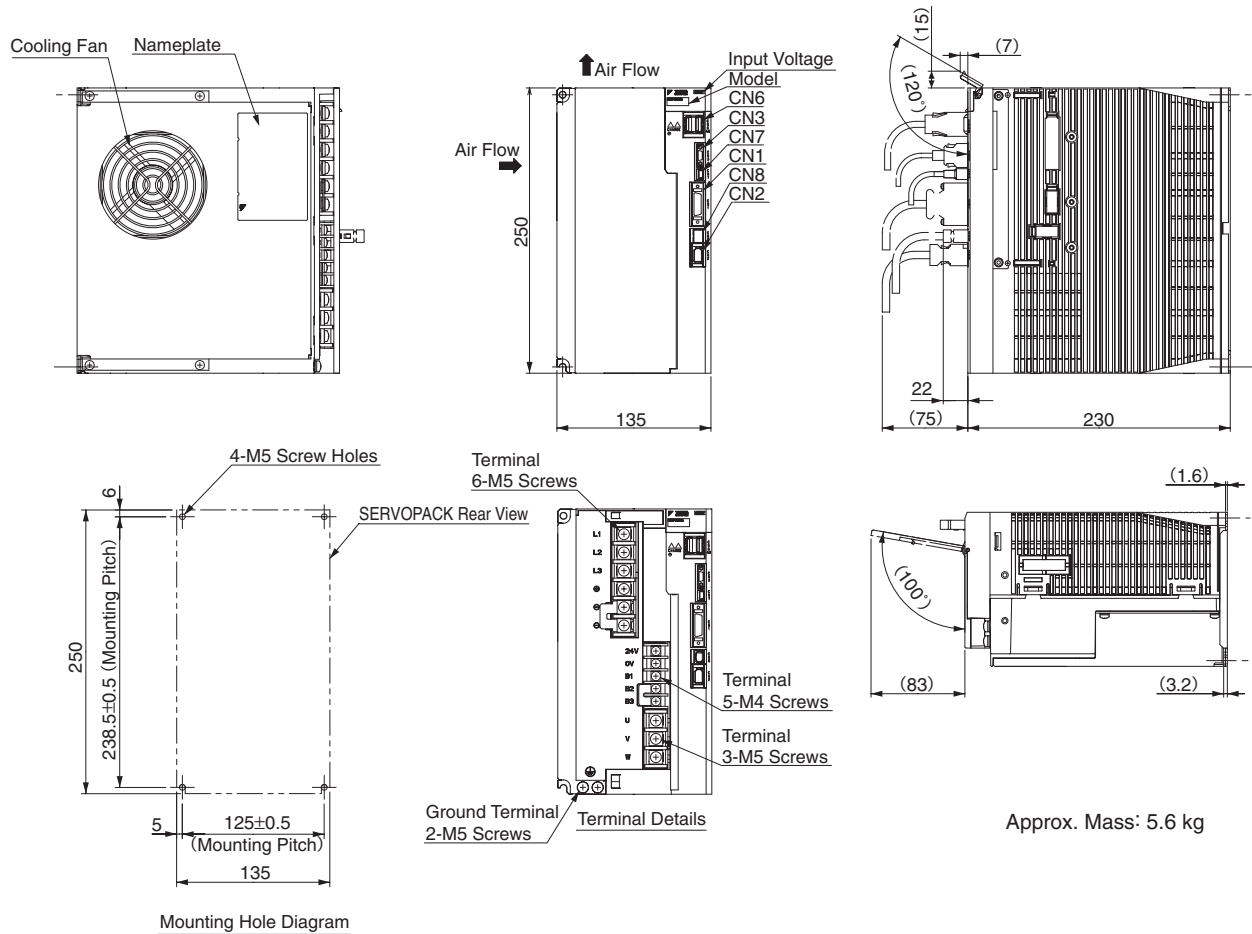

Connectors for Base-mounted SERVOPACKs

Port	Model	Pin	Manufacturer
CN1	10226-52A2PL	26	Sumitomo 3M Ltd.
CN2	53984-0671	6	Molex Japan Co., Ltd.
CN3	HDR-EC14LFDTN-SLE-PLUS	14	Honda Tsushin Kogyo Co., Ltd.
CN6	1903815-1	8	Tyco Electronics AMP K.K.
CN7	MNC23-5K5H00	5	ADVANCED-CONNECTEK INC.
CN8	1981080-1	8	Tyco Electronics AMP K.K.

Note: The connectors above or their equivalents are used for SERVOPACKs.

External Dimensions Units: mm

● Rack-mounted SERVOPACKS

(1) Three-phase 200 VAC, model: SGDV-R70A1□A001, -R90A1□A001, and -1R6A1□A001

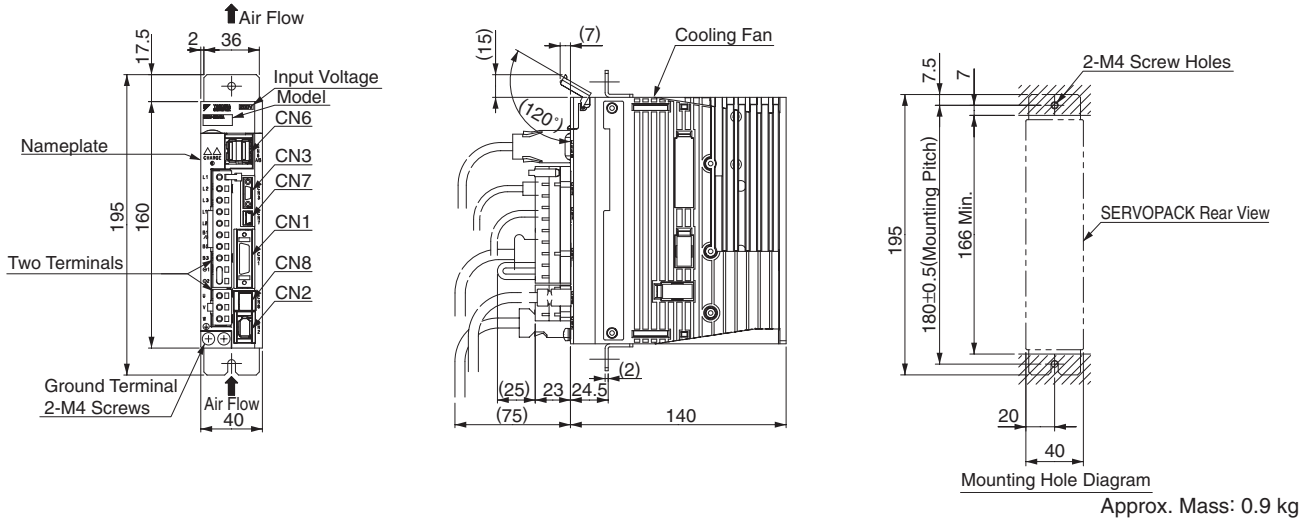

(2) Three-phase 200 VAC, model: SGDV-2R8A1□A001

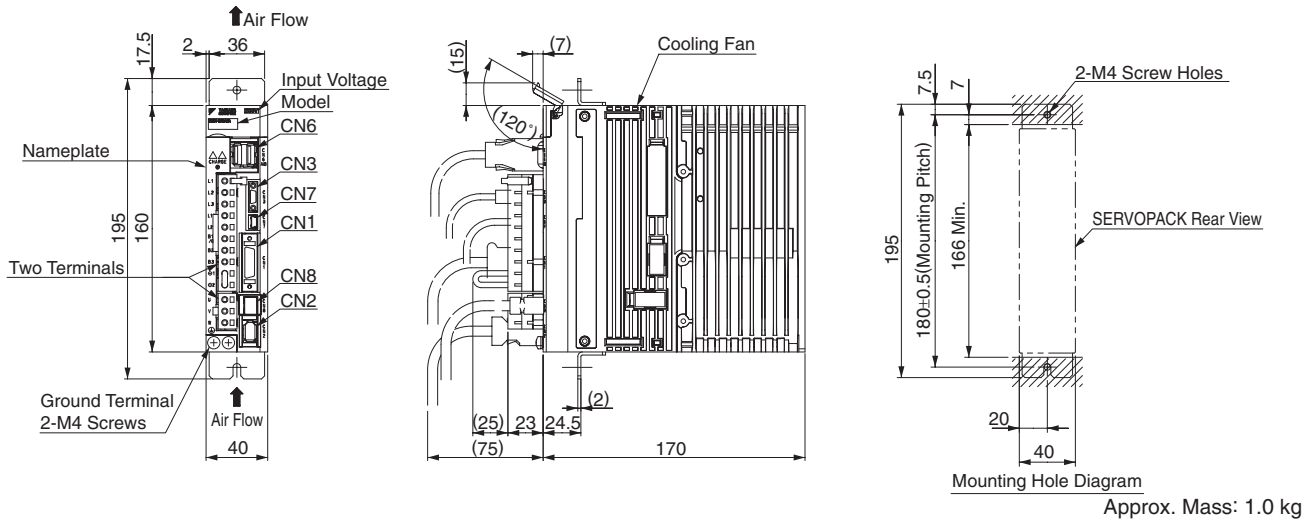

(3) Three-phase 200 VAC, model: SGDV-3R8A1□A001 and -5R5A1□A001

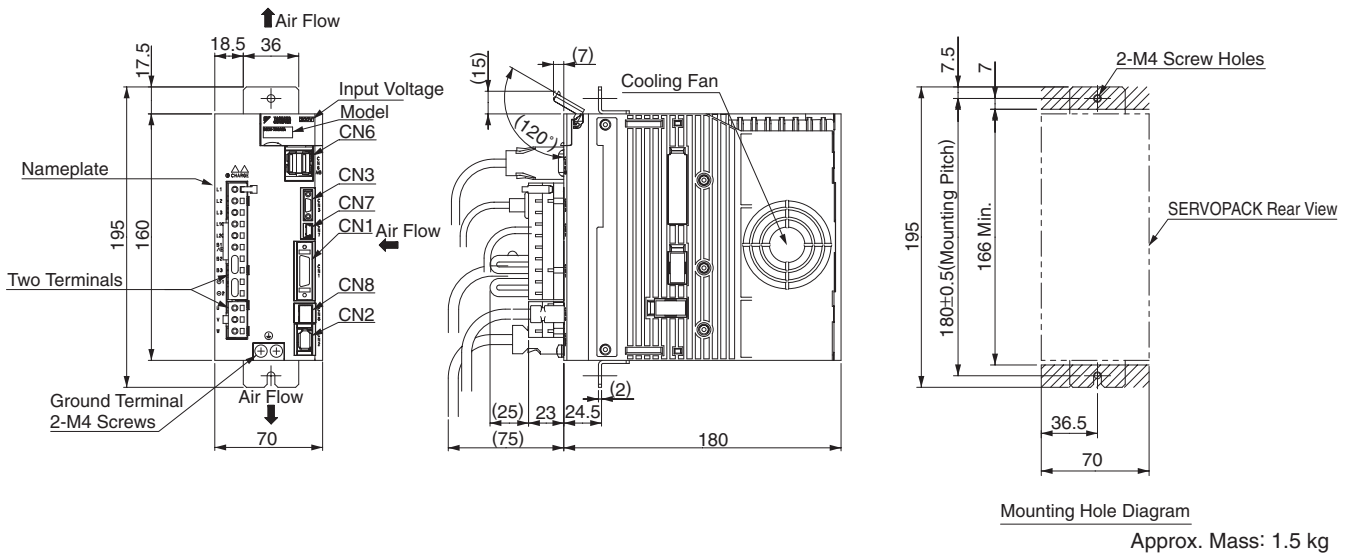

External Dimensions Units: mm

(4) Three-phase 400 VAC, model: SGDV-1R9D1□A001, -3R5D1□A001, and -5R4D1□A001

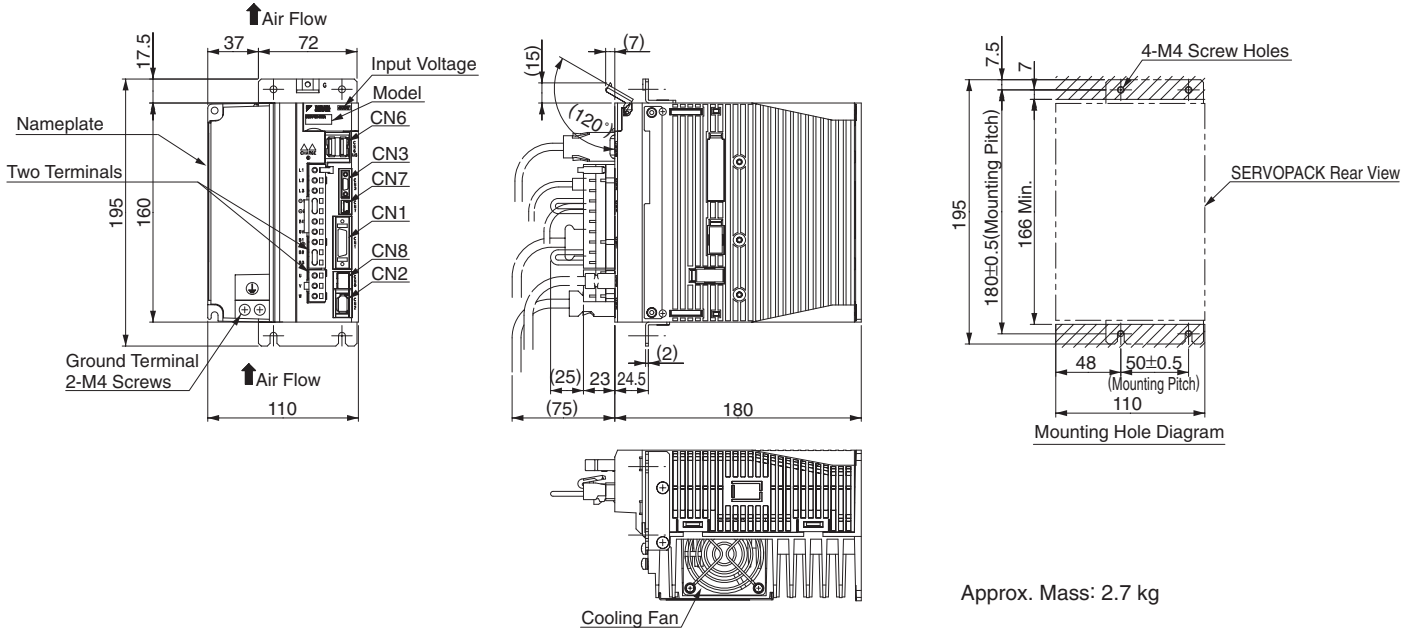

(5) Three-phase 400 VAC, model: SGDV-8R4D1□A001 and -120D1□A001

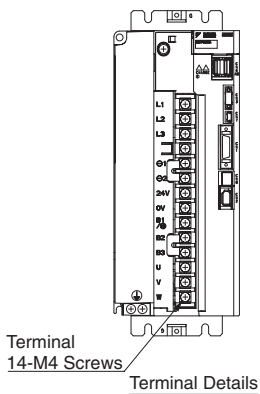
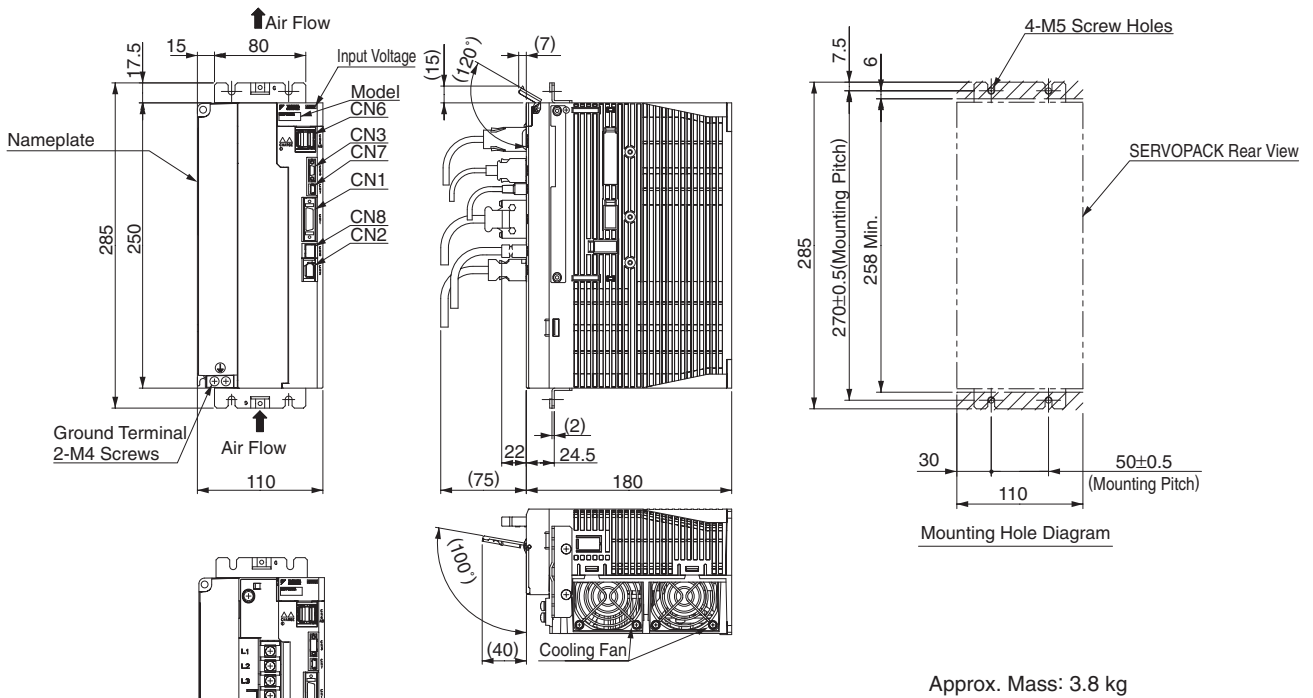

M-II Type SERVOPACKs

External Dimensions Units: mm

(6) Three-phase 400 VAC, model: SGD-V170D1 □A001

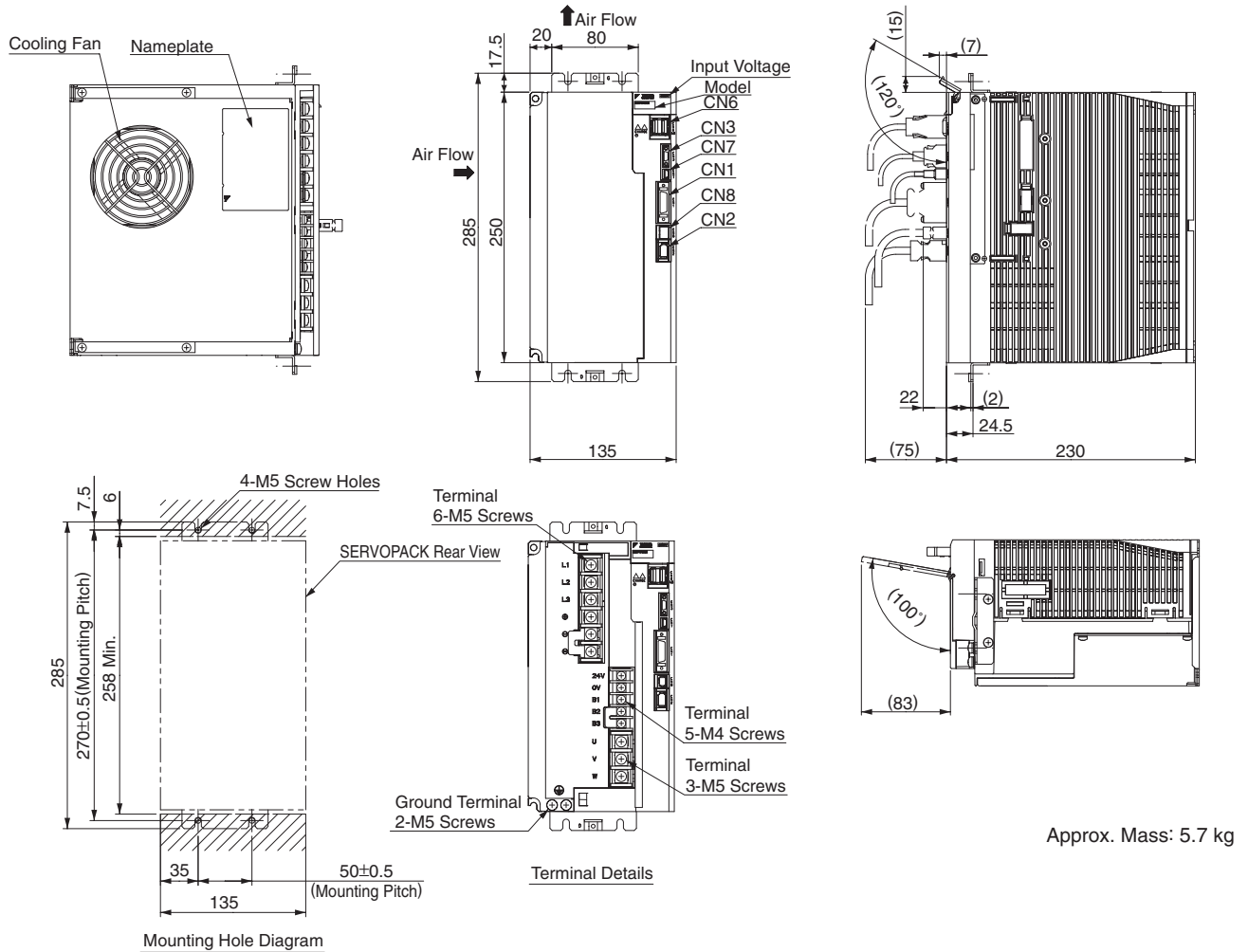

Connectors for Rack-mounted SERVOPACKs

Port	Model	Pin	Manufacturer
CN1	10226-52A2PL	26	Sumitomo 3M Ltd.
CN2	53984-0671	6	Molex Japan Co., Ltd.
CN3	HDR-EC14LFDN-SLE-PLUS	14	Honda Tsushin Kogyo Co., Ltd.
CN6	1903815-1	8	Tyco Electronics AMP K.K.
CN7	MNC23-5K5H00	5	ADVANCED-CONNECTEK INC.
CN8	1981080-1	8	Tyco Electronics AMP K.K.

Note: The connectors above or their equivalents are used for SERVOPACKs.

Selecting Cables

● Cables for **CN1** **CN3** **CN5** **CN6** **CN7** **CN8** (MECHATROLINK-II Communications Reference Type SERVOPACKs)

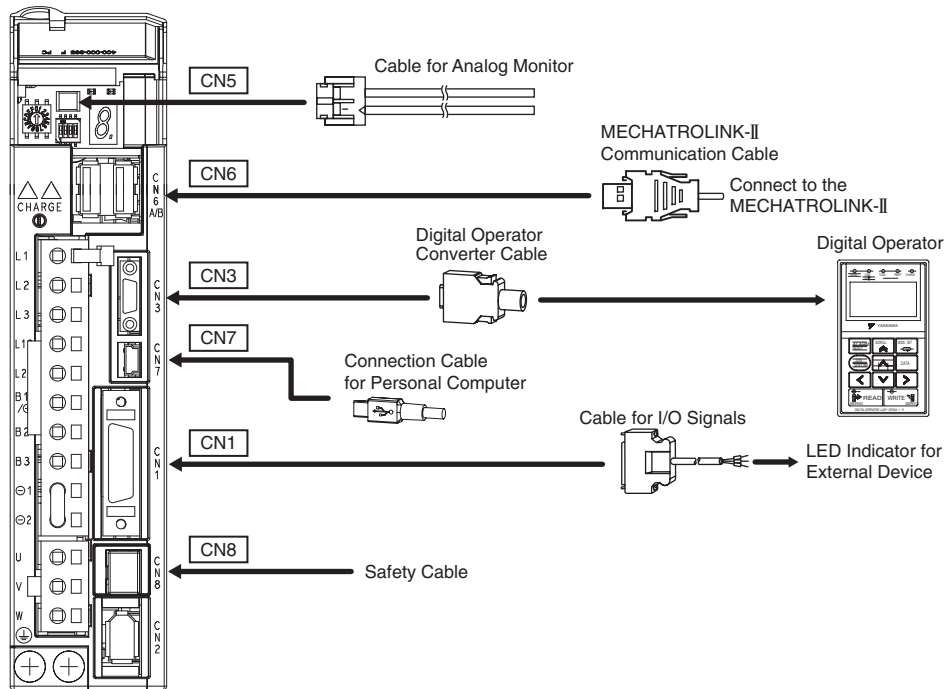

Name		Length	Order No.	Specifications	Details
CN1 Cables for I/O Signals	Connector Kit		JZSP-CS19-2-E	Soldered	
	Connector		Connector: 10126-3000PE Case: 10326-52A0-008 (Sumitomo 3M Ltd.)		(1)
CN3	Digital Operator		JUSP-OP05A-1-E	With Connection Cable (1 m)	 (2)
	Digital Operator Converter Cable*1		JZSP-CVS05-A3-E	Cable with Connectors at Both Ends (0.3 m)	 (3)
CN7	Connection Cables for Personal Computer		JZSP-CVS06-02-E		-
CN6A CN6B MECHATROLINK-II Communication Cable	Cables with Connectors at Both Ends	0.5 m	JEPMC-W6002-A5-E		(5)
		1 m	JEPMC-W6002-01-E		
	-	JEPMC-W6002-□□-E			
	Terminator		JEPMC-W6022-E		(6)
CN5 Cables for Analog Monitor		1 m	JZSP-CA01-E	SERVOPACK End 	(4)
CN8 Cables for Safety Functions	Cables with Loose Wires at One End*2		JZSP-CVH03-03-E		-

*1 : A converter cable is required to use Σ -III series digital operators (model: JUSP-OP05A) for Σ -V series SERVOPACKs.

*2 : When using the safety function, connect this cable to the safety devices.

Even when not using the safety function, use SERVOPACKs with the Safe Jumper Connector (model: JZSP-CVH05-E) connected.

Selecting Cables Units: mm

(1) Connector Kit for CN1

Use the following connector and cable to assemble the cable.
The CN1 connector kit includes one case and one connector.

Connector Kit Model	Case		Connector	
	Model	Qty	Model	Qty
JZSP-CS19-2-E	10326-52A0-008*	1 set	10126-3000PE* (Soldered)	1

* : Manufactured by Sumitomo 3M Ltd.

• Cable Size

Item	Specifications
Cable	Use twisted-pair or twisted-pair shielded wire.
Applicable Wires	AWG24, 26, 28, 30
Cable Finished Diameter	16 dia. max.

• Dimensional Drawings of Case

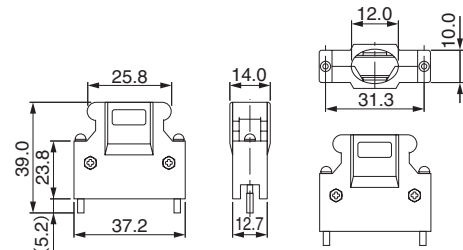

(2) Digital Operator (Model: JUSP-OP05A-1-E)

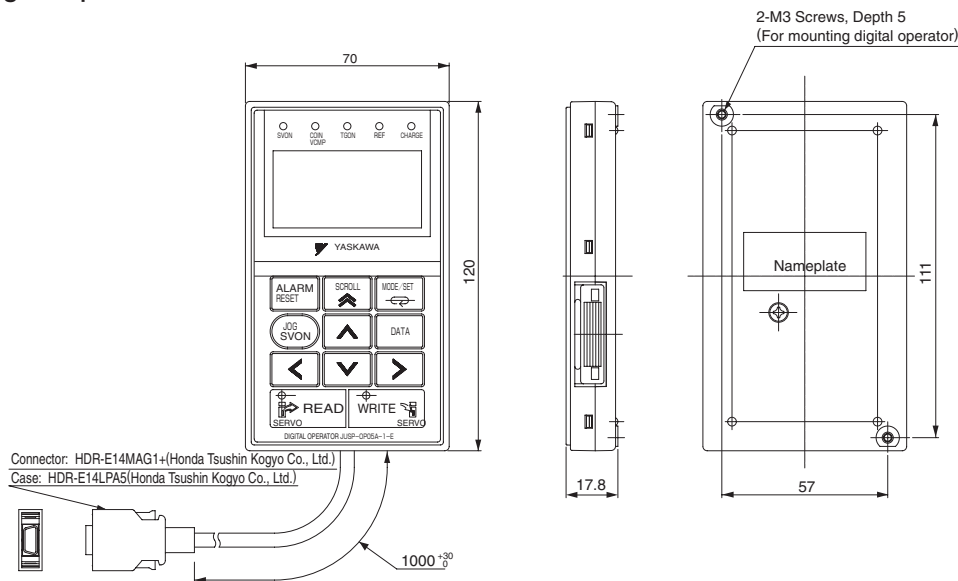

(3) Digital Operator Converter Cable for CN3 (Model: JZSP-CVS05-A3-E)

A converter cable is required to use Σ -III series digital operators (model: JUSP-OP05A) for Σ -V series SERVOPACKs.

• Dimensional Drawings

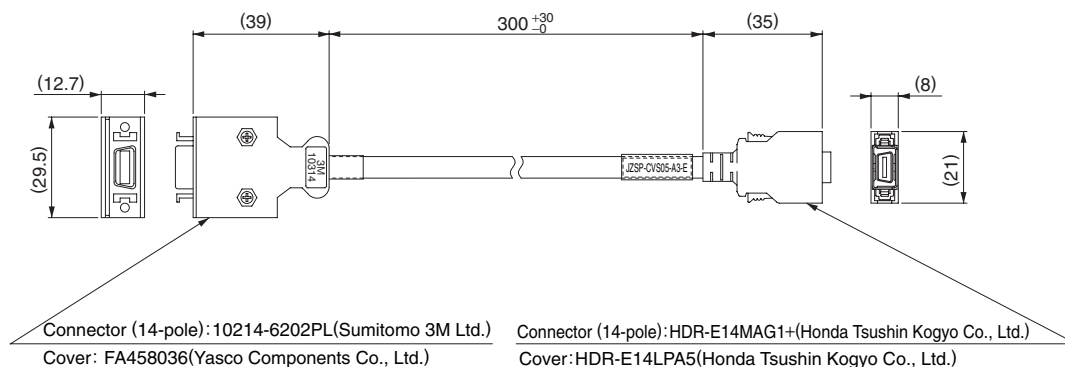

Selecting Cables Units: mm

(4) Cable for Analog Monitor for CN5

· Dimensional Drawings

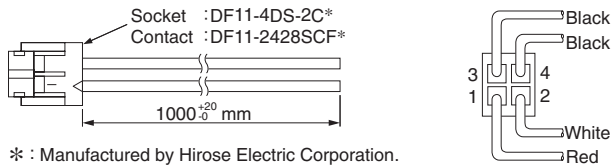

* : Manufactured by Hirose Electric Corporation.

View from Cable End

· Specifications

Pin No.	Cable Color	Signal	Standard Settings
1	Red	Analog Monitor 2	Motor speed : 1V/1000 min ⁻¹
2	White	Analog Monitor 1	Torque reference : 1V/100% rated torque
3, 4	Black (2 cables)	GND(0V)	—

Note : The specifications above are factory settings. Monitor specifications can be changed by changing parameters Pn006 and Pn007.

(5) MECHATROLINK-II Communication Cable for CN6

· Dimensional Drawings



Model	Cable Length (L)
JZPMC-W6002-A5-E	0.5 m
JZPMC-W6002-01-E	1.0 m
JZPMC-W6002-□□-E	□□ is the ordered length [m]

(6) MECHATROLINK-II Communication Cable Terminator for CN6 (Model : JEPMC-W6022-E)

· Dimensional Drawings

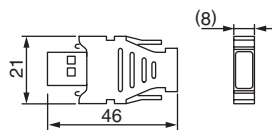

Serial Converter Units for Fully-closed Loop Control

● System Configuration for Fully-closed Loop Control

A fully-closed option card is required for fully-closed loop control of rotary servomotors. Contact your Yaskawa representatives for more details.

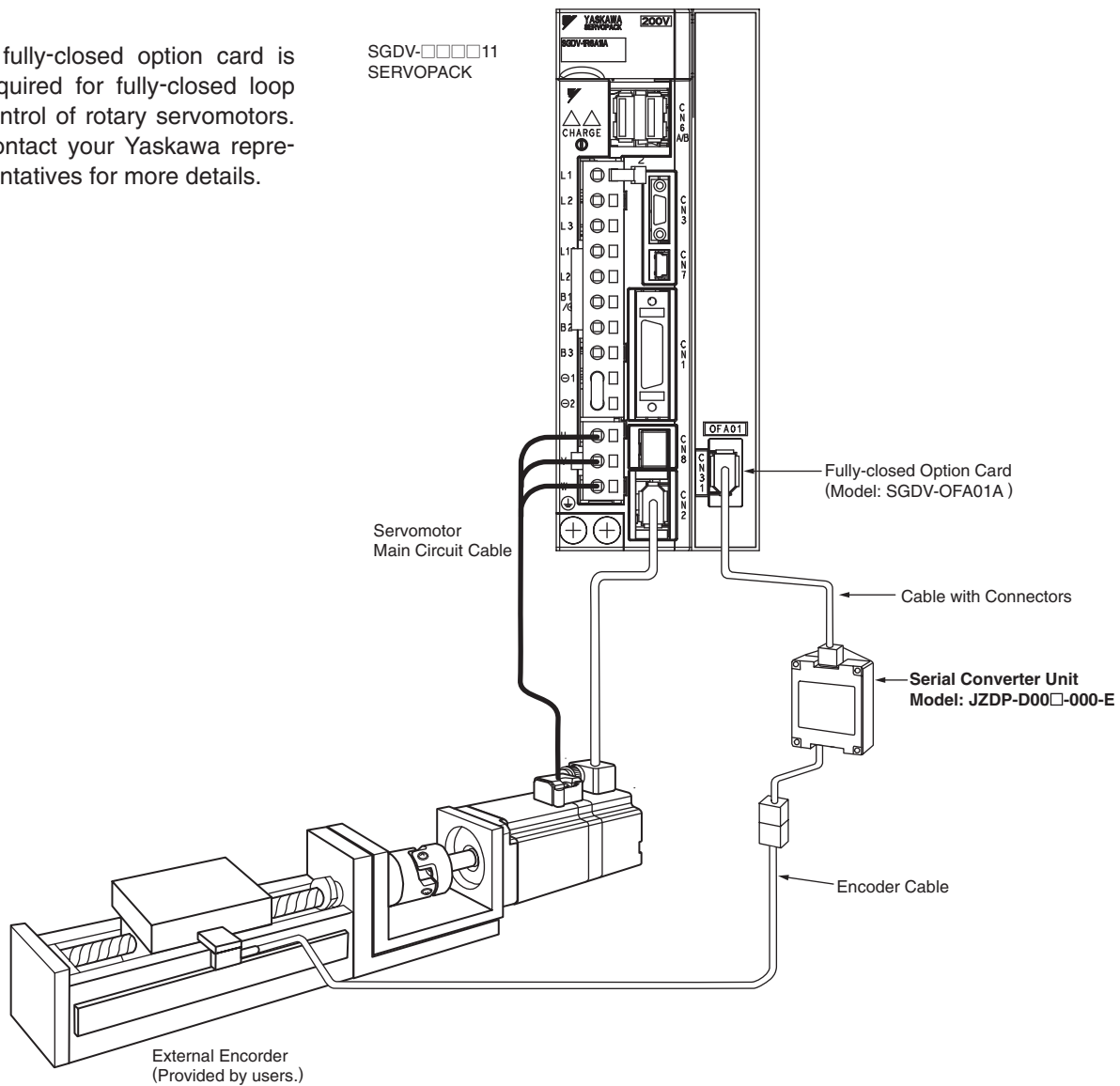

● Model Designations

JZDP - D00□ - 000 - E

Serial Converter Unit Model			
Code	Appearance	Applicable External Encoder	Hall Sensor
D003		Manufactured by HEIDENHAIN Corporation	None
D005		Manufactured by Renishaw plc.	None

Note: Using the serial converter unit JZDP-A□□□ with SGDV SERVOPACK will void our guarantee.

Serial Converter Units for Fully-closed Loop Control

● Characteristics and Specifications

Items	Specifications	
Electrical Characteristics	Power Supply Voltage	+5.0 V±5%, ripple content 5% max.
	Current Consumption*1	120 mA typ. 350 mA max.
	Signal Resolution	Input two-phase sine wave: 1/256 pitch
	Max. Response Frequency	250 kHz
	Analog Input Signals*2 (cos, sin, Ref)	Differential input amplitude: 0.4 to 1.2 V Input signal level: 1.5 to 3.5 V
	Output Signal*3	Position data, alarms
	Output Method	Serial data communications [HDLC (High-level Data Link Control) protocol format with Manchester codes]
	Transmission Cycle	62.5 μs
	Output Circuit	Balanced type transceiver (SN75LBC176 or the equivalent), internal terminating resistor: 120 Ω
Mechanical Characteristics	Approx. Mass	150 g
	Vibration Resistance	98 m/s ² max. (10 to 2500 Hz) in three directions
	Impact Resistance	980 m/s ² , (11 ms) two times in three directions
Environmental Conditions	Operating Temperature	0 to 55°C
	Storage Temperature	-20 to +80°C
	Humidity	20% to 90%RH (no condensation)

*1: The current consumption of the external encoder is not included in this value.

The current consumption of the external encoder must be taken into consideration for the current capacity of host controller that supplies the power.

*2: Input a value within the specified range. Otherwise, incorrect position information is output, and the device may be damaged.

*3: The transmission is enabled 100 to 300 ms after the power turns on.

● Analog Signal Input Timing

The following figure shows the input timing of the analog signals.

When the cos and sin signals are shifted 180 degrees, the differential signals are the /cos and /sin signals.

The specifications of the cos, /cos, sin, and /sin signals are identical except for the phase.

Input the signals Ref and /Ref so that they shall cross each other as shown in the figure because they are input into the converter. When they are crossed, the output data will be counted up.

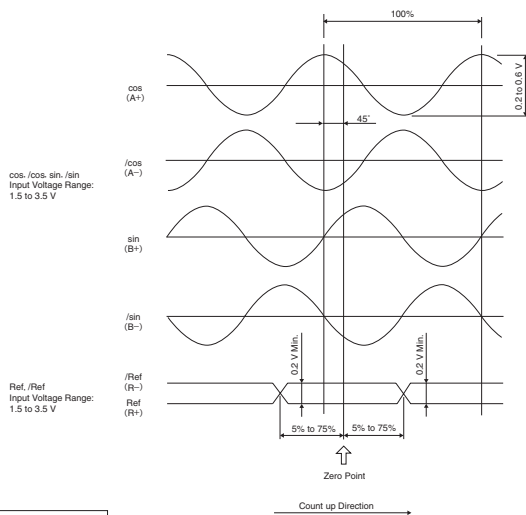

IMPORTANT

■ Precautions

- 1 Never perform insulation resistance and withstand voltage tests.
- 2 When analog signals are input to the serial converter unit, noise influence on the analog signals affects the unit's ability to output correct position information. The analog cable must be as short as possible and shielded.
- 3 Do not connect or disconnect the unit while power is being supplied, or the unit may be damaged.
- 4 When using multiple axes, use a shield cable for each axis. Do not use a shield cable for multiple axes.

Serial Converter Units for Fully-closed Loop Control

External Dimensions (Units: mm)

(1) Model: JZDP-D003-□□□-E

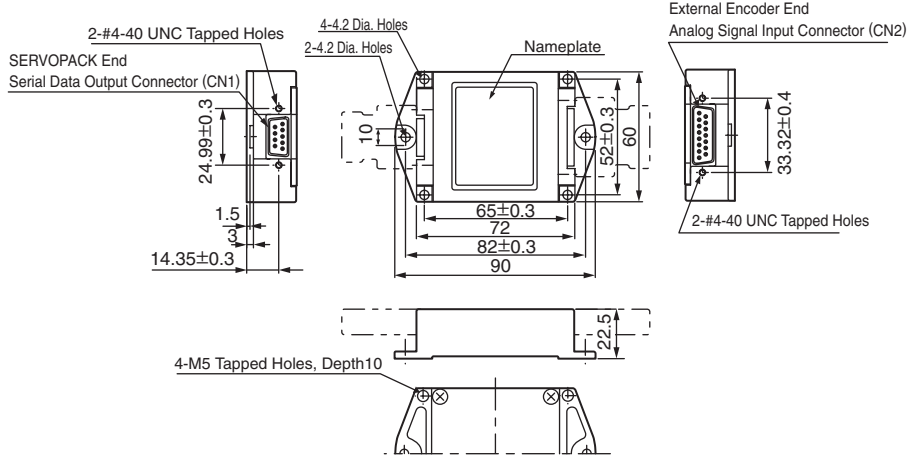

(2) Model: JZDP-D005-□□□-E

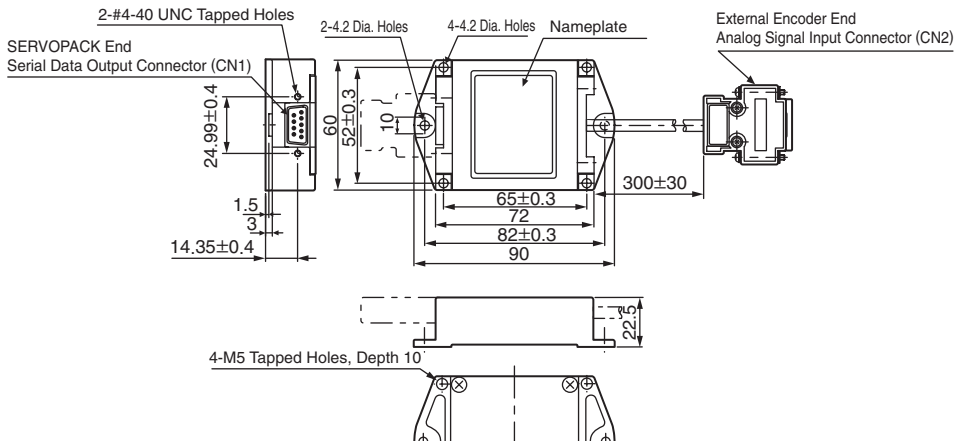

Connection Cables

Recommended Cables

Name	Application	Model	Length
Cables with Connectors at Both Ends	Connection between SERVOPACK (Fully-closed option card) connector CN31 and serial converter unit	JZSP-CLP70-03-E	3 m
		JZSP-CLP70-05-E	5 m
		JZSP-CLP70-10-E	10 m
		JZSP-CLP70-15-E	15 m
		JZSP-CLP70-20-E	20 m

Dimensional Drawing

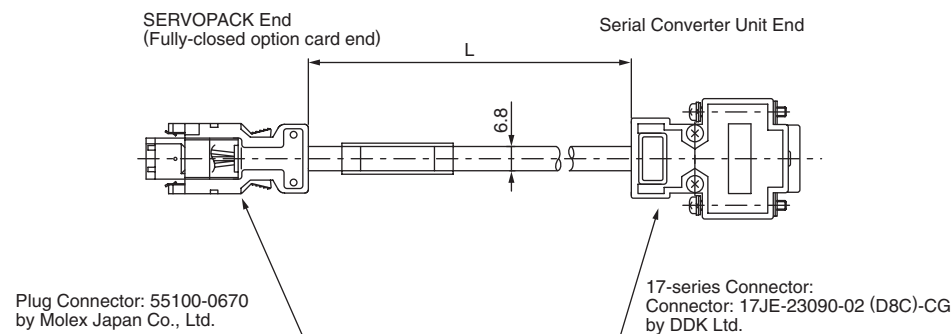

Serial Converter Units for Fully-closed Loop Control Units: mm

● Connection Examples

(1) Connection Example with External Encoder by HEIDENHAIN Corporation

· Model: JZDP-D003-□□□□-E

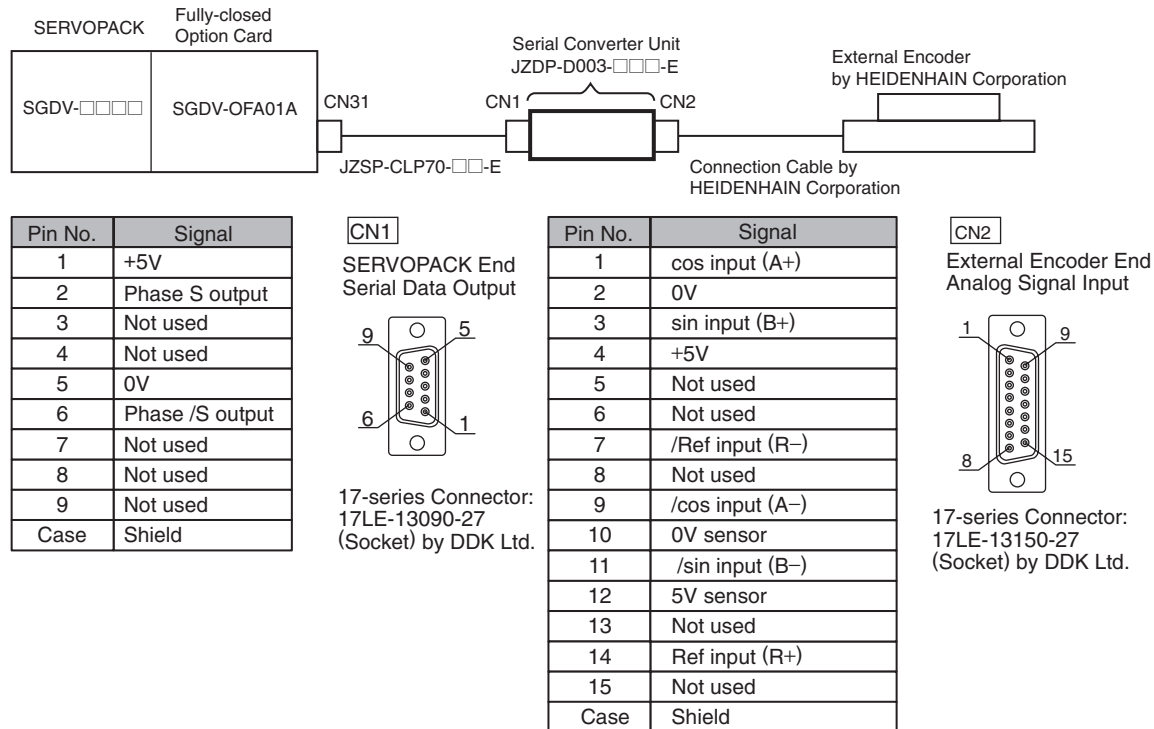

Notes: 1 Do not use the unused pins.

2 The external encoder (analog 1 Vp-p output, D-sub 15-pin) by HEIDENHAIN Corporation can be directly connected.

(2) Connection Example with External Encoder by Renishaw plc.

· Model : JZDP-D005-□□□□-E

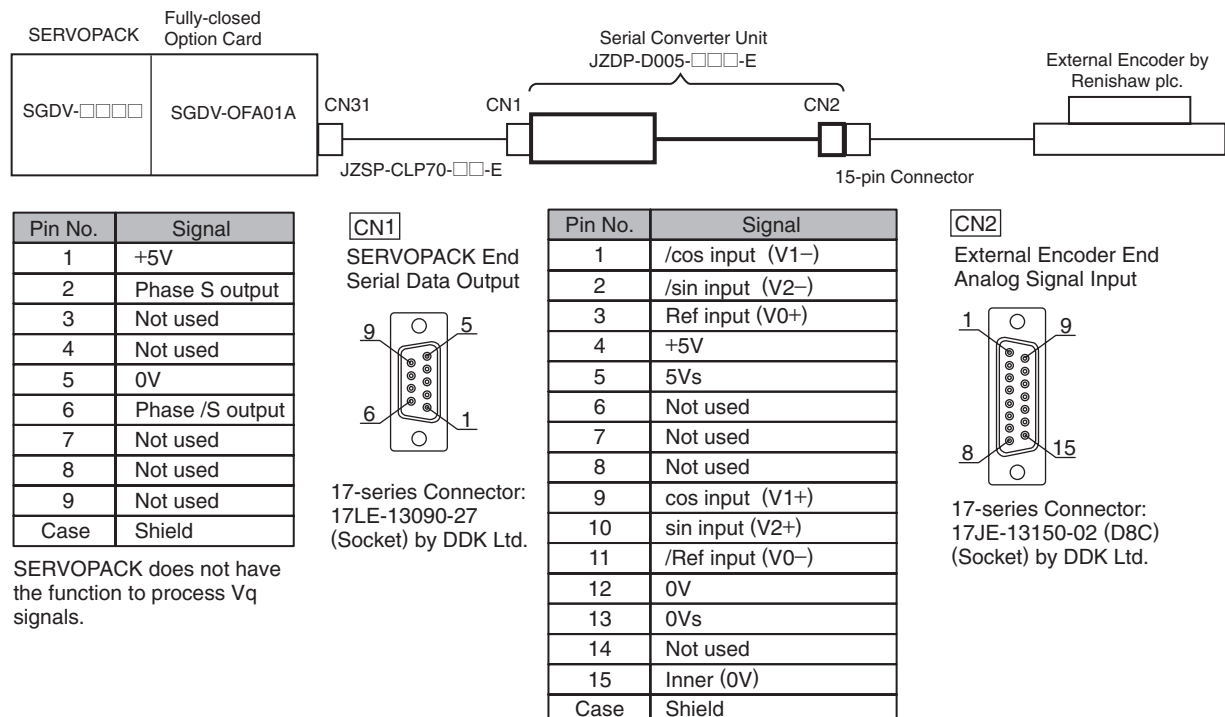

SERVOPACK does not have the function to process Vq signals.

Notes: 1 Do not use the unused pins.

2 The external encoder (analog 1 Vp-p output, D-sub 15-pin) by Renishaw plc. can be directly connected. However, the BID and DIR signals are not connected.

3 Use the external encoder-end connector to change the home position specifications of the external encoder.

Serial Converter Units for Fully-closed Loop Control

- (3) Connection Example with External Encoder by Mitutoyo Corporation (Model: ABS ST78□A)
When using this external encoders, serial converter units are not required.

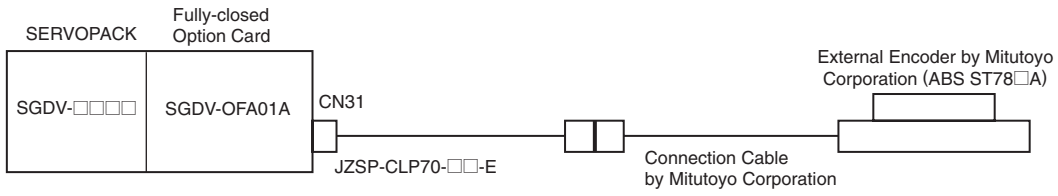



Wiring Main Circuit and Peripheral Devices

Wiring Main Circuit

● Typical Main Circuit Wiring Examples

This section describes the typical main circuit wiring examples.

⚠ WARNING

Do not touch the power terminals for five minutes after turning OFF the power. High voltage may still remain in the SERVOPACK. When the voltage is discharged, the charge indicator will turn OFF. Make sure the charge indicator is OFF before starting wiring or inspections.

● Three-phase 200 V

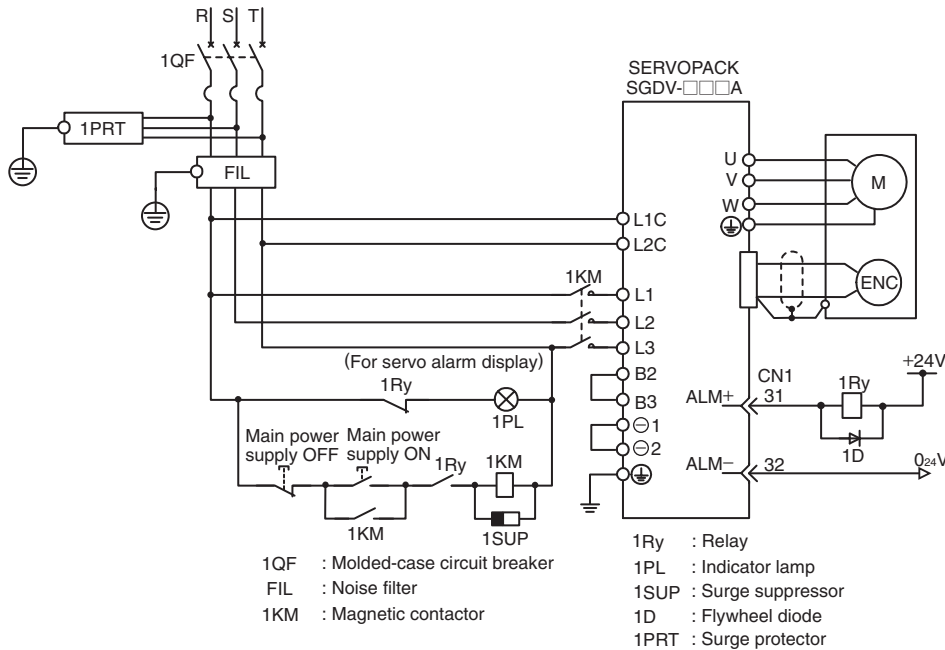

● Three-phase 400 V

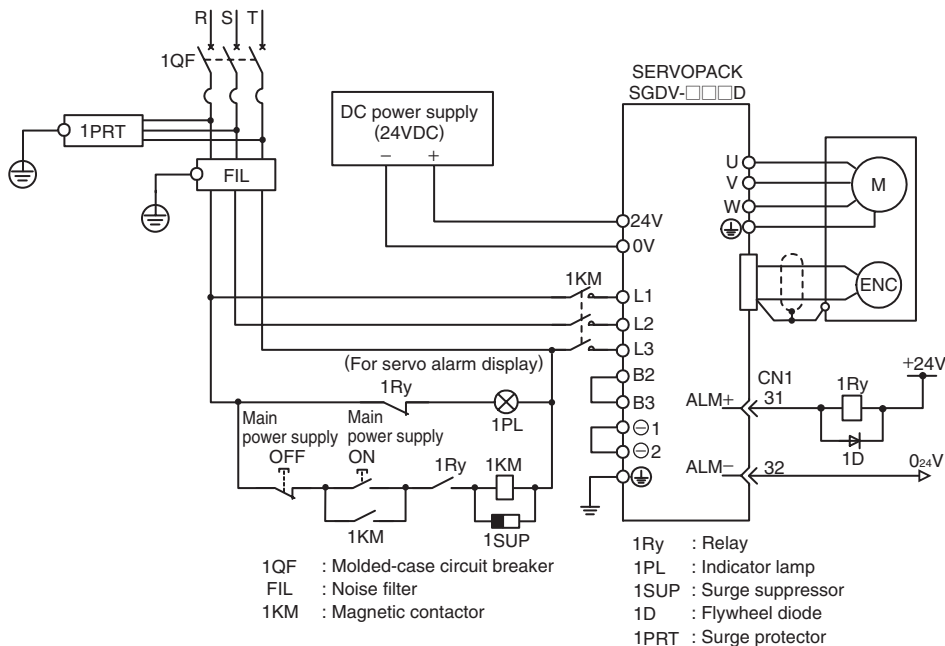

Wiring Main Circuit

● General Precautions for Wiring

IMPORTANT

- Use a molded-case circuit breaker (QF) or fuse to protect the Main Circuit.
- The SERVOPACK connects directly to a commercial power supply; it is not isolated through a transformer or other device.
- Always use a molded-case circuit breaker (QF) or fuse to protect the servo system from accidents involving different power system voltages or other accidents.
- The SERVOPACK does not have a built-in protective circuit for grounding.
- To configure a safer system, install a ground fault detector against overloads and short-circuiting, or install a ground fault detector combined with a molded-case circuit breaker.
- Do not turn power ON and OFF frequently. Do not turn power ON and OFF more than once per minute.
- The power supply in the SERVOPACK contains a capacitor, which causes a high charging current to flow when power is turned ON. Frequently turning power ON and OFF will cause the main circuit elements in the SERVOPACK to deteriorate.

To ensure safe, stable application of the servo system, observe the following precautions when wiring.

Observe the following precautions when wiring the main circuit.

- Use shielded twisted-pair wires or shielded multi-core twisted-pair wires for signal lines and encoder lines.
- The maximum wiring length is 3 m for signal lines and 50 m for encoder lines.

Observe the following precautions when wiring the ground.

- Use a cable as thick as possible (at least 2.0 mm²)
- Grounding to a resistance of 100 Ω or less is recommended.
- Be sure to ground at only one point.
- Ground the servomotor directly if the servomotor is insulated from the machine.

The signal cable conductors are as thin as 0.2 mm or 0.3 mm. Do not impose excessive bending force or tension.

● Precautions When Using the SERVOPACK with a DC Power Input

When using the SERVOPACK with a DC power input, set parameter Pn001.2 to 1, and pay attention to the following items.

WARNING

- Either AC or DC power can be input to the 200 V, 400 V SERVOPACKs.
Always set Pn001.2 to 1 to specify a DC power input before inputting DC power.
If DC power is input without changing the parameter setting, the SERVOPACK's internal elements will burn and may cause fire or equipment damage.
- With a DC power input, time is required to discharge electricity after the main power supply is turned OFF. A high residual voltage may remain in the SERVOPACK after the power supply is turned OFF. Be careful not to get an electric shock.
- Install fuses on the wires if DC power is used.

Wiring Main Circuit

● DC Power Supply Input Terminals for the Main and Control Circuits

· 200 V

SERVOPACK Model SGDV-	Terminal Name and Description		
	Main Circuit Plus Terminal	Main Circuit Minus Terminal	Control Power Supply Input Terminal
	270 V to 320 VDC	0 VDC	270 V to 320 VDC (No polarity) 200 V to 230 VAC
R70D, R90A, 1R6A 2R8A, 3R8A, 5R5A	B1/⊕	⊖ 2	+24 V, 0 V

· 400 V

SERVOPACK Model SGDV-	Terminal Name and Description		
	Main Circuit Plus Terminal	Main Circuit Minus Terminal	Control Power Supply Input Terminal
	513 V to 648 VDC	0 VDC	24 VDC (± 15%)
1R9D, 3R5D, 5R4D 8R4D, 120D	B1	⊖ 2	+24 V, 0 V
170D	B1/⊕	⊖ 2	+24 V, 0 V

● Wiring Example with DC Power Supply Input

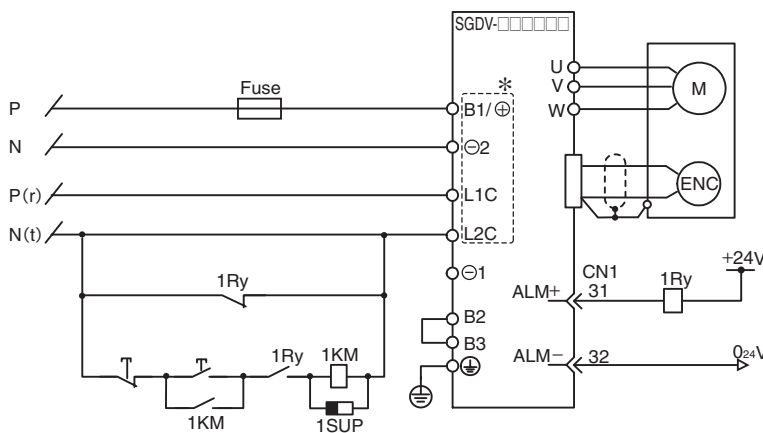

1KM : Magnetic Contactor *: Terminal names differ from model of SERVOPACK.
 1Ry : Relay Refer to "DC Power Supply Input Terminals for the
 1SUP : Surge Suppressor Main and Control Circuits."

Notes: 1 The SERVOPACK that can use a DC power supply is not capable of processing the regenerated energy. Provide measures to process the regenerated energy on the power supply.
 2 Set a fuse to DC power supply cables.

● Parameter Setting

When using a DC power supply, make sure to set the parameter Pn001.2 to "1" (DC power input supported) before inputting DC power.

Turn OFF the power, and then turn it ON again to make the setting valid.

Parameter	Meaning
Pn001	n. □0□□ AC power input supported
	n. □1□□ DC power input supported

Wiring Main Circuit

● Precautions When Using More Than One SERVOPACK

This section shows an example of the wiring when more than one SERVOPACK is used and the precautions.

● Wiring Example

Connect the alarm output (ALM) terminals for the three SERVOPACKs in series to enable alarm detection relay 1RY to operate. When the alarm occurs, the ALM output signal transistor is turned OFF.

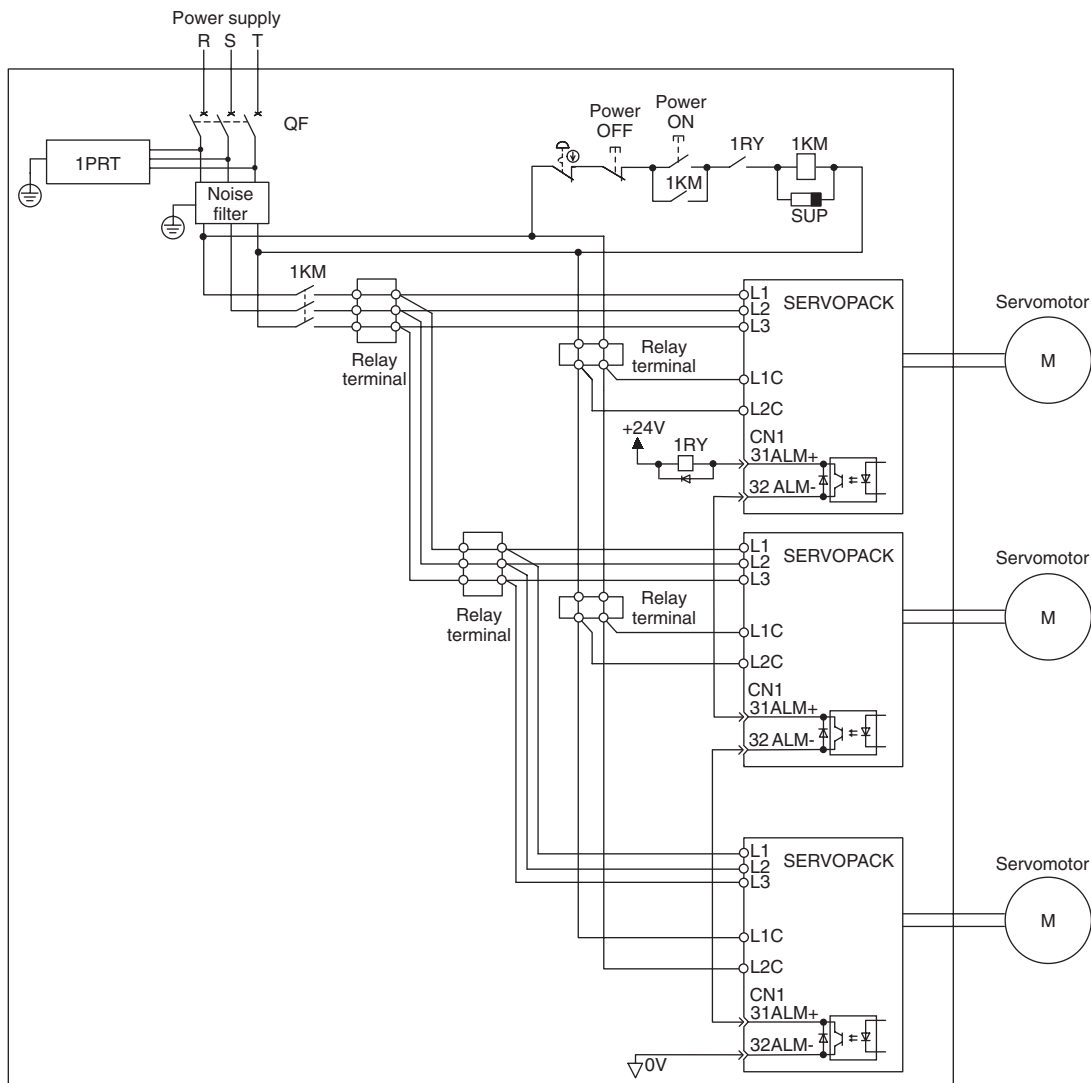

● Precautions

Multiple servos can share a single molded-case circuit breaker (QF) or noise filter. Always select a QF or noise filter that has enough capacity for the total power capacity (load conditions) of those servos.

SERVOPACK Main Circuit Wire

● Three-phase, 200 V

Cables	Terminal Symbol	SERVOPACK Model SGD V-					
		R70A	R90A	1R6A	2R8A	3R8A	5R5A
Main Circuit Power Cable	L1, L2, L3	HIV1.25			HIV2.0		
Servomotor Main Circuit Cable	U, V, W	HIV1.25			HIV2.0		
Control Power Cable	L1C, L2C	HIV1.25					
External Regenerative Resistor Cable	B1, B2	HIV1.25					
Ground Cable	⊕	HIV2.0 min.					

● Three-phase, 400 V

Cables	Terminal Symbol	SERVOPACK Model SGD V-					
		1R9D	3R5D	5R4D	8R4D	120D	170D
Main Circuit Power Cable	L1, L2, L3	HIV1.25			HIV2.0		HIV3.5
Servomotor Main Circuit Cable	U, V, W	HIV1.25			HIV2.0		HIV3.5
Control Power Cable	24V, 0V	HIV1.25					
External Regenerative Resistor Cable	B1, B2	HIV1.25			HIV1.25		HIV2.0
Ground Cable	⊕	HIV2.0 min.					

● Cable Type

Cable Type		Allowable Conductor Temperature °C
Code	Name	
PVC	Normal vinyl cable	-
IV	600-V vinyl cable	60
HIV	Temperature-resistant vinyl cable	75

The following table shows the size and allowable currents for the cables. Use a cable whose specifications meet or are less than the values in the table.

● 600-V Heat-resistant Vinyl Cable (HIV)

Nominal Cross Section Diameter mm ²	AWG size	Allowable Current at Ambient Temperatures A		
		30°C	40°C	50°C
0.5	20	6.6	5.6	4.5
0.75	-	8.8	7.0	5.5
0.9	18	9.0	7.7	6.0
1.25	16	12.0	11.0	8.5
2.0	14	23	20	16
3.5	12	33	29	24
5.5	10	43	38	31
8.0	8	55	49	40
14.0	6	79	70	57
22.0	4	91	81	66

Note: The values in the table are only for reference.

IMPORTANT

- 1 Wire sizes are selected for three cables per bundle at 40°C ambient temperature with the rated current.
- 2 Use a cable with a minimum withstand voltage of 600 V for the main circuit.
- 3 If cables are bundled in PVC or metal ducts, take into account the reduction of the allowable current.
- 4 Use a heat-resistant cable under high ambient or panel temperatures, where normal vinyl cables will rapidly deteriorate.

Molded-case Circuit Breaker and Fuse Capacity

Main Circuit Power Supply	Applicable Servomotor Max. Capacity kW	SERVOPACK Model SGDv-	Power Supply Capacity per SERVOPACK kVA	Current Capacity		Inrush Current	
				Main Circuit Arms	Control Circuit Arms	Main Circuit A0-p	Control Circuit A0-p
Three-phase 200 V	0.05	R70A	0.2	1.0	0.2	33	70
	0.1	R90A	0.3	1.0			
	0.2	1R6A	0.6	2.0			
	0.4	2R8A	1	3.0		33	33
	0.5	3R8A	1.4	3.0			
	0.75	5R5A	1.6	6.0			
Three-phase 400 V	0.5	1R9D	1.1	1.4	1.2	17	-
	1.0	3R5D	2.3	2.9			
	1.5	5R4D	3.5	4.3			
	2.0	8R4D	4.5	5.8	1.4	34	
	3.0	120D	7.1	8.6			
	5.0	170D	11.7	14.5			

Note: To comply with the low voltage directive, connect a fuse or molded-case circuit breaker to the input side. Select the fuse or molded-case circuit breaker for the input side from among models that are compliant with UL standards.

Noise Filters

● Noise Filter Selection

Recommended noise filters are available from Yaskawa Controls Co., Ltd.

Main Circuit Power Supply	SERVOPACK Model SGD V-	Recommended Noise Filter		Main Circuit Power Supply	SERVOPACK Model SGD V-	Recommended Noise Filter	
		Model	Specifications			Model	Specifications
Three-phase 200 V	R70A	FN258L-7/07	Three-phase 480V 7A	Three-phase 400 V	1R9D	FN258L-7/07	Three-phase 480V 7A
	R90A				3R5D		
	1R6A				5R4D		
	2R8A				8R4D	FN258L-16/07	Three-phase 480V 16A
	3R8A				120D		
	5R5A	FN258L-16/07	Three-phase 480V 16A		170D	FMAC-0934-5010	Three-phase 480V 50A

Note: RoHS-compliant models are not available. Contact the manufactures when in need of an RoHS-compliant model.

● External Dimensions (Units: mm)

(1) FN Type (by SCHAFFNER)

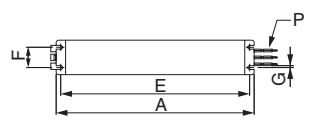
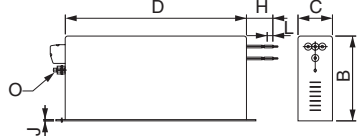
Model		FN258L-7/07	FN258L-16/07
Dimensional Drawings		Side View 	Front and Side View 
	Code	Dimensions	
External Dimensions	A	225±1	305±1
	B	126±0.8	142±0.8
	C	50±0.6	55±0.6
	D	225±0.8	275±0.8
	E	240±0.5	290±0.5
	F	25±0.3	30±0.3
	G	6.5±0.2	
	H	300±10	
	J	1±0.1	
	L	9±1	
	O	M5	
	P	AWG16	AWG14

Noise Filters

(2) FMAC Type [by SCHURTER (formerly TIMONTA)]

Model		FMAC-0934-5010	
Dimensional Drawings			
External Dimensions mm	Code	Dimensions	
	A	251	
	B	201	
	C	151	
	D	135 ⁺⁰ ₋₁	
	E	6.5 ± 0.3	
	F	115 ± 0.3	
	G	M6	
	H	66	
	I	121	
	J	(10)	
	K	(41)	
L	(17)		

Surge Protector

● Surge Protector Selection

The surge protector absorbs lightning surge and prevents faulty operation in or damage to electronic circuits. Recommended surge protectors are listed below.

Main Circuit Power Supply	SERVOPACK Model SGD V-	Surge Protector	Main Circuit Power Supply	SERVOPACK Model SGD V-	Surge Protector
Three-phase 200 V	R70A	R · C · M-601BQZ-4	Three-phase 400 V	1R9D	Built-in
	R90A			3R5D	
	1R6A			5R4D	
	2R8A			8R4D	
	3R8A			120D	
	5R5A			170D	

Notes: 1 Contact Okaya Electric Industries Co., Ltd.

2 RoHS-compliant models are not available. Contact the manufacturers when in need of an RoHS-compliant model.

● External Dimensions (Units: mm)

Model: R · C · M-601BQZ-4

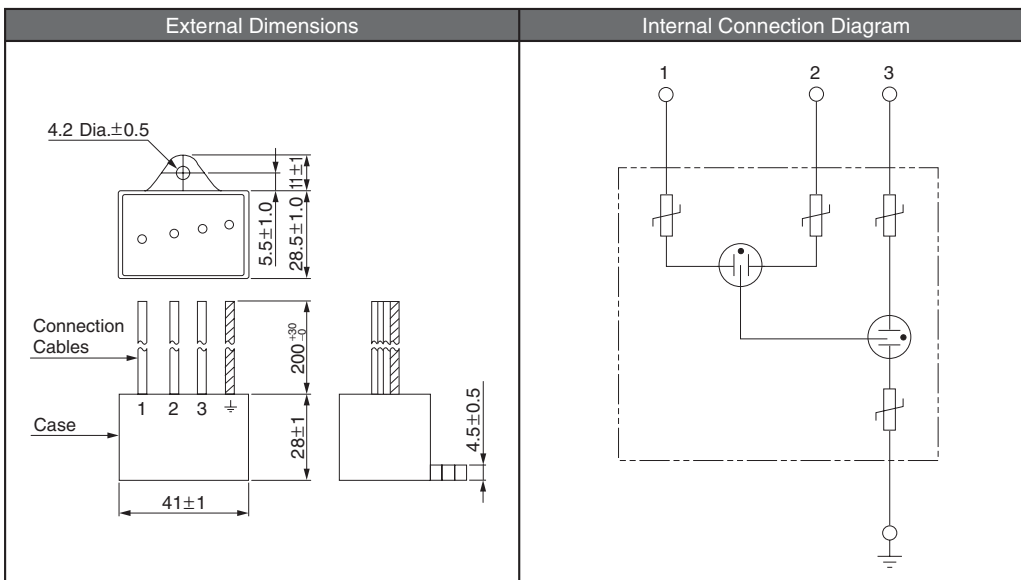

Magnetic Contactors

● Magnetic Contactor Selection

A magnetic contactor is required to make the AC power to SERVOPACK ON/OFF sequence externally. Be sure to attach a surge suppressor (surge absorber unit etc.) to the excitation coil of the magnetic contactor.

Main Circuit Power Supply	SERVOPACK Model SGDV-	Magnetic Contactor		Main Circuit Power Supply	SERVOPACK Model SGDV-	Magnetic Contactor*	
		Model	Specifications			Model	Specifications
Three-phase 200 V	R70A	SC-03	(RoHS)	Three-phase 400 V	1R9D	SC-4-1/G	Coil 24 VDC (RoHS)
	R90A						
	1R6A						
	2R8A						
	3R8A						
	5R5A	SC-4-1	(RoHS)		170D	SC-N2S/G	Coil 24 VDC (RoHS)

* : Contact Fuji Electric FA Components & Systems Co., Ltd.

● External Dimensions (Units: mm)

· SC-03

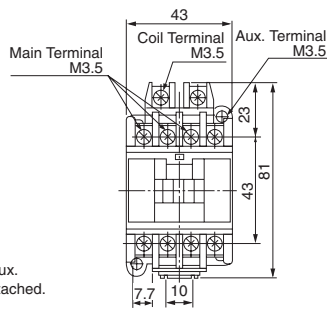
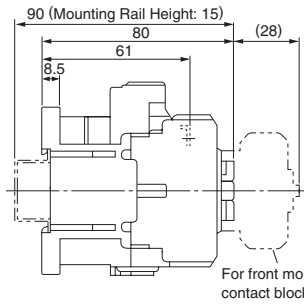

Mounting Hole Dimensions

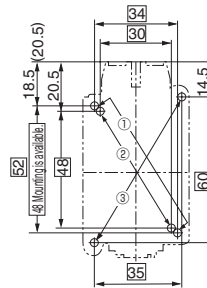

● Mounting methods : The following methods ①, ②, ③ are available.

①...34 × (48 to) 52

②...30 × 48

③...35 × 60

● Mounting screw : 2-M4

Use the two mounting holes on the diagonal line to mount a contactor.

Approx. Mass : 0.32 kg

Aux. Contact	Structure
1a	
1b	

· SC-4-1

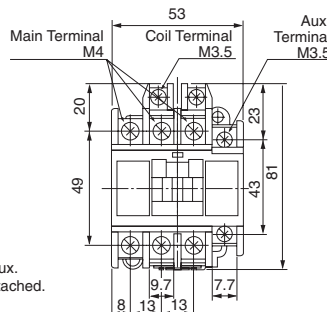
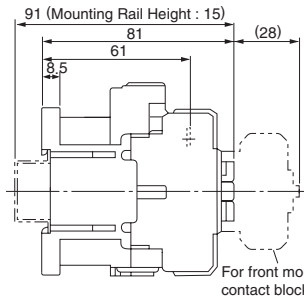

Mounting Hole Dimensions

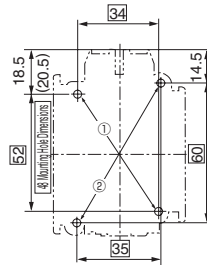

● Mounting methods : The following methods ①, ② are available.

①...34 × (48 to) 52

②...30 × 60

● Mounting screw : 2-M4

Use the two mounting holes on the diagonal line to mount a contactor.

Approx. Mass : 0.36 kg

Aux. Contact	Structure
1a	
1b	

Magnetic Contactor

• SC-4-1/G

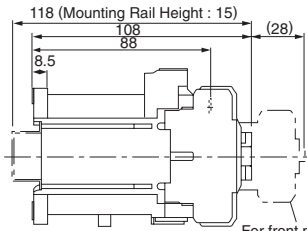

For front mounting, aux. contact blocks are attached.

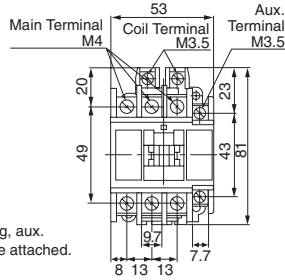

Mounting Hole Dimensions

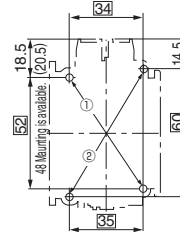

Aux. Contact	Structure
1a	
1b	

• Mounting methods : The following methods ①, ② are available.

- ①...34 × (48 to) 52
- ②...35 × 60

• Mounting screw : 2-M4

Use the two mounting holes on the diagonal line to mount a contactor.

Approx. Mass : 0.6 kg

• SC-5-1/G

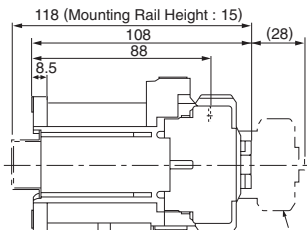

For front mounting, aux. contact blocks are attached.

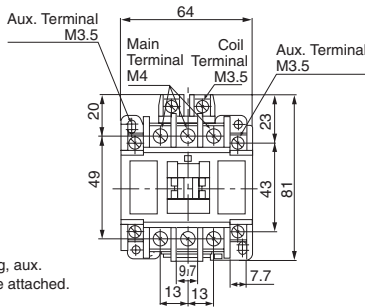

Mounting Hole Dimensions

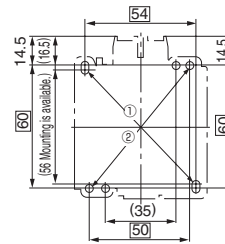

Aux. Contact	Structure
2a	
1a1b	
2b	

• Mounting methods : The following methods ①, ② are available.

- ①...54 × (56 to) 60
- ②...50 × 60

• Mounting screw : 2-M4

Use the two mounting holes on the diagonal line to mount a contactor.

Approx. Mass : 0.62 kg

• SC-N2S/G

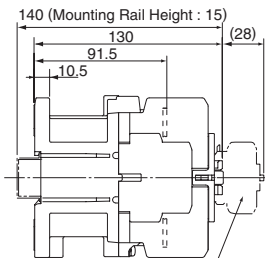

For front mounting, aux. contact blocks are attached.

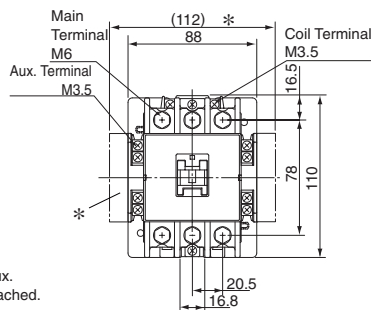

*: For two side mounting, aux. contact blocks attached.

Mounting Hole Dimensions

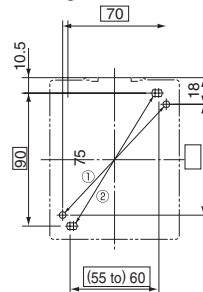

Structure	
(31)	(23)(41)
(32)	(24)(42)

• Mounting methods : The following methods ①, ② are available.

- ①...70 × 75
- ②...((55 to) 65) × 90

• Mounting screw : 2-M4

Use the two mounting holes on the diagonal line to mount a contactor.

Approx. Mass : 1.4 kg

DC Reactors

● Selection

Contact Yaskawa Controls Co., Ltd. If the power supply harmonic suppression is needed, connect a DC reactor between the SERVOPACK main circuit terminals ⊖ 1 and ⊖ 2.

Select a reactor that matches the ratings of the SERVOPACK.

Main Circuit Power Supply	SERVOPACK SGD V-	DC Reactor Model	Main Circuit Power Supply	SERVOPACK SGD V-	DC Reactor Model
Three-phase 200 V	R70A	X5061	Three-phase 400 V	1R9D	X5074
	R90A			3R5D	X5075
	1R6A			5R4D	X5076
	2R8A			8R4D	
	3R8A			120D	X5077
	5R5A			170D	

Notes: RoHS-compliant models are not available. The last digit of an RoHS-compliant model number is R. Contact the manufacturers when selecting an RoHS compliant model.

● External Dimensions (Units: mm)

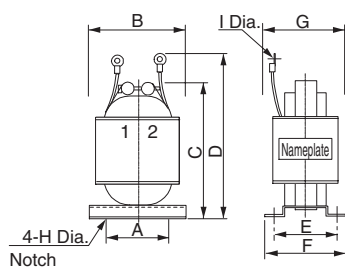

DC Reactor Model	External Dimensions									Approx. Mass kg
	A	B	C	D	E	F	G	H Dia.	I Dia.	
X5061	35	52	80	95	35	45	50	4	4.3	0.5
X5074	30	47	70	85	28	38	45	4	4.3	0.3
X5075	40	59	100	120	40	50	55	4	4.3	0.9
X5076	50	74	125	140	35	45	60	5	4.3	1.1
X5077	50	74	125	155	53	66	75	5	5.3	1.9

Regenerative Resistors

● Regenerative Resistor Selection

When regenerative energy is so large that a SERVOPACK cannot process, install externally a regenerative resistor. The regenerative resistor is provided by customers. Refer to the table below for selecting the regenerative resistor.

Voltage	SERVOPACK Model SGDV-	Built-in Regenerative Resistor	Necessity of External Regenerative Resistors	Necessity of External Regenerative Resistors
200 VAC	R70A, R90A, 1R6A, 2R8A	None	Basically Not Required	No built-in regenerative resistor is provided, however, normally an external regenerative resistor is not required. Install external regenerative resistors when the smoothing capacitor in SERVOPACK cannot process all the regenerative power.
	3R8A, 5R5A	Standard Equipment	Basically Not Required	A built-in regenerative resistor is provided as standard. Install external regenerative resistors when the built-in regenerative resistor cannot process all the regenerative power.
400 VAC	□□□D	Standard Equipment	Basically Not Required	A built-in regenerative resistor is provided as standard. Install external regenerative resistors when the built-in regenerative resistor cannot process all the regenerative power.

● References for External Resistor (by Iwaki Musen Kenkyusho Co., Ltd.)

Model	Specifications
RH120	70 W, 1 to 100 Ω
RH150	90 W, 1 to 100 Ω
RH220□	120 W, 1 to 100 Ω
RH300C	200 W, 1 to 10 kΩ
RH500	300 W, 1 to 30 Ω

Note: Contact the manufacturers when in need of an RoHS-compliant model.

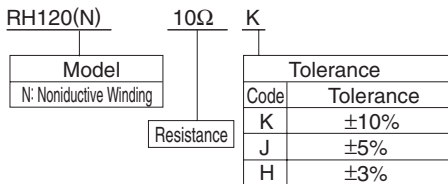

● Specifications

Resistance Tolerance	K : ±10%, J : ±5%, H : ±3%
Temperature Resistance Characteristics	±400PPM / °C (20 Ω max.), ±260PPM / °C (20 Ω min.)
Withstand Voltage	2000 VAC / min. ΔR : ± (0.1%+0.05 Ω)
Insulation Resistance	500 VDC, 20 MΩ min.
Short-time Overload	When 10 times of rated power is applied for five seconds, ΔR : ±(2%+0.05 Ω)
Life	1000 hours of repeating the operation ON for 90 minutes and OFF for 30 minutes, ΔR : ± (5%+0.05 Ω)
Heat Resistance	Not ignite after having applied 10 times of rated power for one minute
Operating temperature	-25 to +150°C

● External Dimensions (Units: mm)

RH120, 150, 220		RH220B																																													
<p>Lead wire length L = 300</p> <table border="1"> <thead> <tr> <th>Model</th> <th>Rated Power</th> <th>Resistance</th> <th>Dimensions</th> <th>A</th> <th>B</th> <th>C</th> <th>D</th> <th>E</th> <th>F</th> <th>G</th> </tr> </thead> <tbody> <tr> <td>RH120</td> <td>70 W</td> <td>1Ω to 100Ω</td> <td>RH120</td> <td>182</td> <td>150</td> <td>172</td> <td>16</td> <td>42</td> <td>22</td> <td>20</td> </tr> <tr> <td>RH150</td> <td>90 W</td> <td>1Ω to 100Ω</td> <td>RH150</td> <td>212</td> <td>180</td> <td>202</td> <td>16</td> <td>44</td> <td>24</td> <td>30</td> </tr> <tr> <td>RH220</td> <td>120 W</td> <td>1Ω to 100Ω</td> <td>RH220</td> <td>230</td> <td>200</td> <td>220</td> <td>15</td> <td>60</td> <td>24</td> <td>20</td> </tr> </tbody> </table>		Model	Rated Power	Resistance	Dimensions	A	B	C	D	E	F	G	RH120	70 W	1Ω to 100Ω	RH120	182	150	172	16	42	22	20	RH150	90 W	1Ω to 100Ω	RH150	212	180	202	16	44	24	30	RH220	120 W	1Ω to 100Ω	RH220	230	200	220	15	60	24	20	<p>Lead wire length : L = 500 Rated power : 120 W Resistance : 1 Ω to 100 Ω</p>	
Model	Rated Power	Resistance	Dimensions	A	B	C	D	E	F	G																																					
RH120	70 W	1Ω to 100Ω	RH120	182	150	172	16	42	22	20																																					
RH150	90 W	1Ω to 100Ω	RH150	212	180	202	16	44	24	30																																					
RH220	120 W	1Ω to 100Ω	RH220	230	200	220	15	60	24	20																																					
RH300C		RH500																																													
<p>Lead wire length : L = 300 Rated power : 200 W Resistance : 1 Ω to 10 kΩ</p>		<p>Lead wire length : L = 450 Rated power : 300 W Resistance : 1 Ω to 30 Ω</p>																																													

Holding Brake Power Supply Unit

● Holding Brake Power Supply Unit

IMPORTANT

- We recommend opening or closing the circuit for the holding brake's power supply so that switching will occur on the AC side of the holding brake power supply unit. This will reduce brake operation time compared to switching on the DC side.
- When switching on the DC side, install an extra surge protector apart from the surge protector built in the brake circuit near the brake coil, in order to prevent damage to the brake coil from surge voltage.
- Holding brake power supply units for 24 VDC are not provided by Yaskawa. Please obtain these from other manufacturers. Do not connect holding brake power supply units for different output voltages to SERVOPACKs. Overcurrent may result in burning.

● Model

200 V input: LPSE-2H01-E
100 V input: LPDE-1H01-E

● Specifications

Rated output voltage: 90 VDC
Maximum output current: DC 1.0 A
Lead wire length: 500 mm each
Maximum ambient temperature: 60°C
Lead wires: Color coded (refer to the table below)

AC input		Brake end
100 V	200 V	
Blue/white	Yellow/white	Red/blue

● External Dimensions (Units: mm)

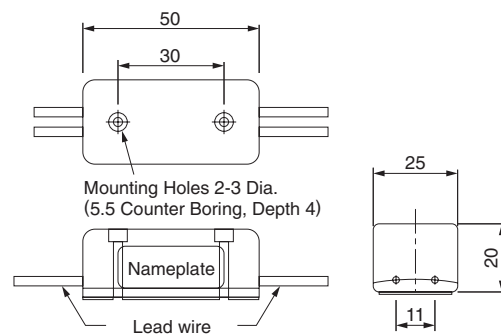

● Internal Circuits

We recommend opening or closing the circuit for the holding brake's power supply so that switching will occur on the AC side of the holding brake power supply unit. This will reduce brake operation time compared to switching on the DC side. When switching on the DC side, install an extra surge protector apart from the surge protector built in the brake circuit near the brake coil, in order to prevent damage to the brake coil from surge voltage.

Brake Power Supply for 200 VAC
Internal Circuit for Model: LPSE-2H01-E

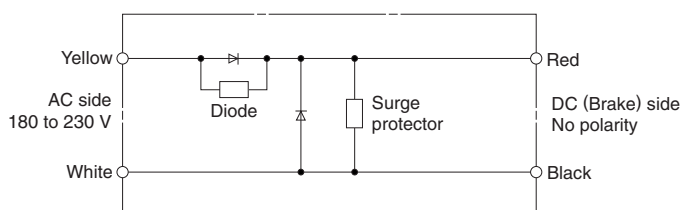

Brake Power Supply for 100 VAC
Internal Circuit for Model: LPDE-1H01-E

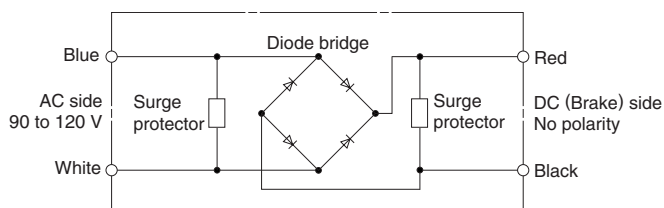



Connection to Host Controller

Example of Connection to Machine Controller MP2□□□

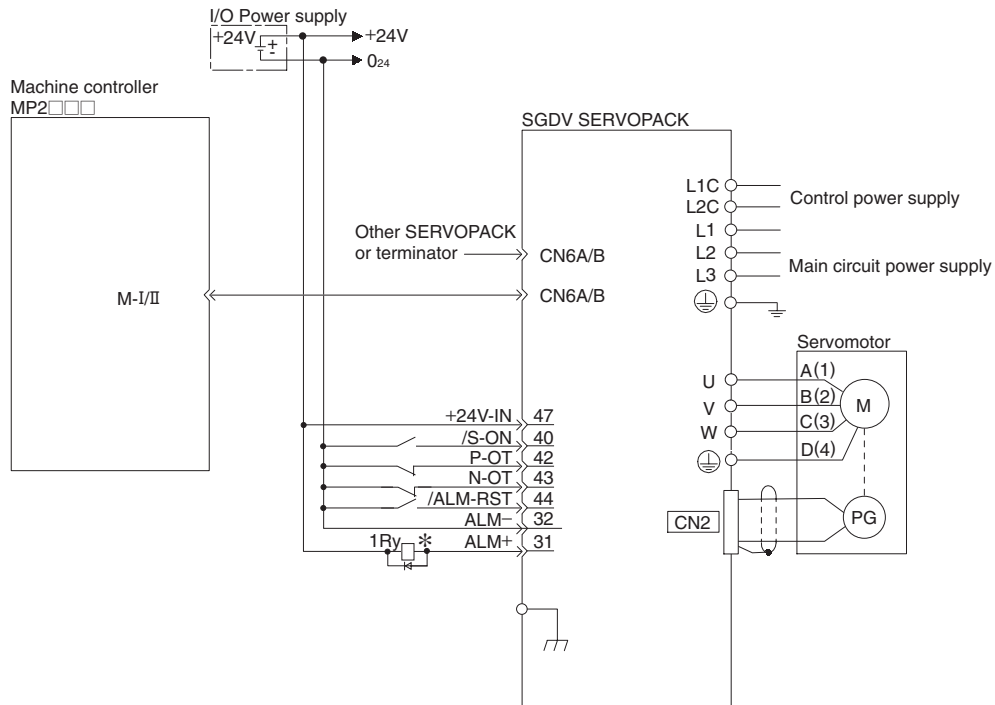

*: The ALM signal is output for about five seconds when the power is turned ON. Take this into consideration when designing the power ON sequence. The ALM signal actuates the alarm detection relay "1Ry" to stop the main circuit power supply to the SERVOPACK.

Example of Connection to MP2200 / MP2300 Motion Module SVA-01

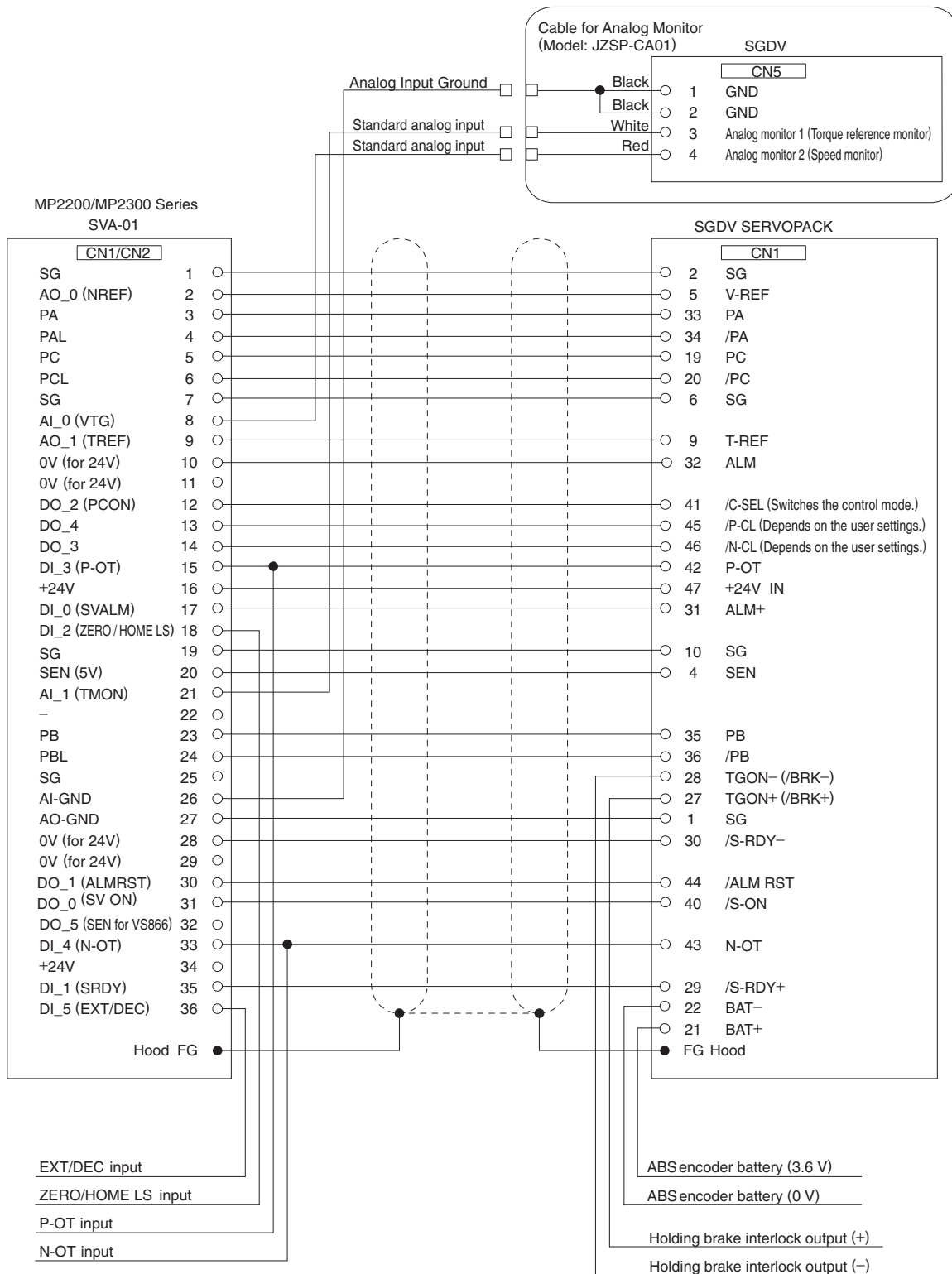

*: Connection cables (model: JEPMC-W 2040-□□) to connect the SERVOPACK to the MP2200/MP2300 are provided by Yaskawa. For details, see "Machine Controller MP2200/MP2300 Motion Module User's Manual" (manual no. SIEPC88070016).

Example of Connection to MP920 4-axes Analog Module SVA-01

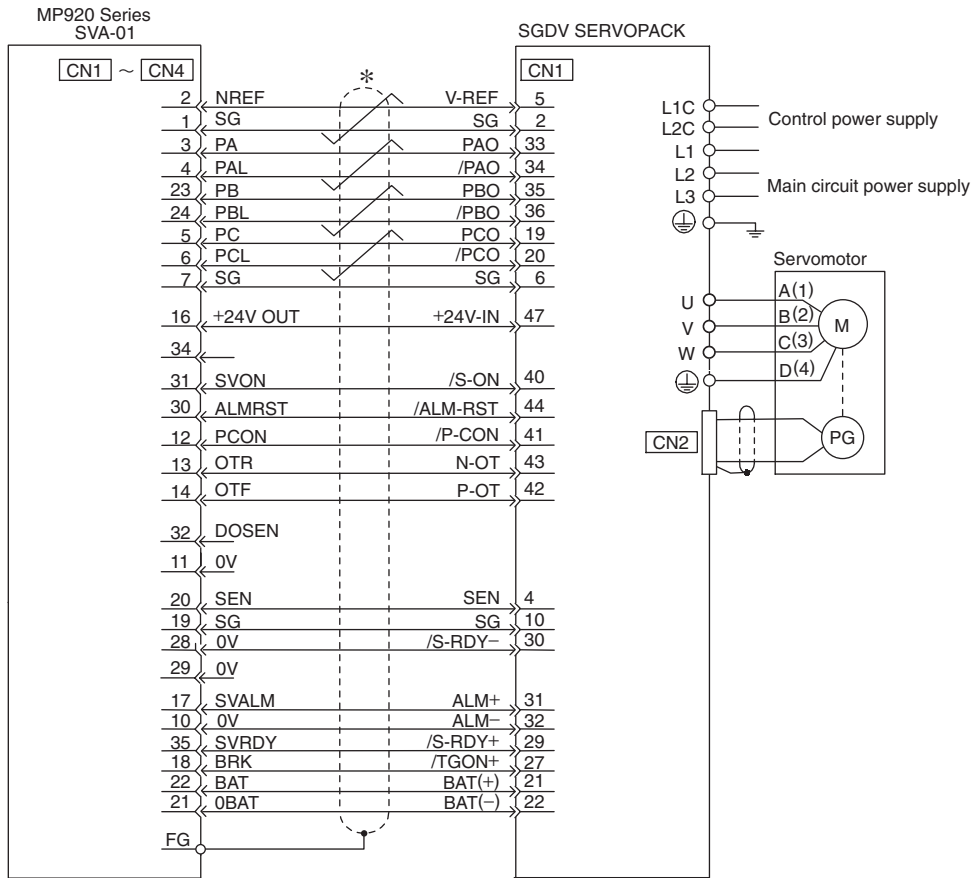

*: represents twisted-pair wires.

Notes: 1 Connection cables (model: JEPMC-W6050-□□) to connect the SERVOPACK to the MP920 are provided by Yaskawa.

For details, see "Machine Controller MP920 User's Manual Design and Maintenance" (manual no. SIEZ-C887-2.1).

2 The SERVOPACK has a built-in safety function to protect prevent anyone in the vicinity from being injured by unexpected motion. But, in order to use the function, the circuit for CN8 is required to be configured. When not using the function, use SERVOPACKs with the Safe Japan Connector connected.

Example of Connection to OMRON's Motion Control Unit

MC unit manufactured
by OMRON Corporation
C200H-MC221
(CS1W-MC221 / MC421)
(CV500-MC221 / MC421)

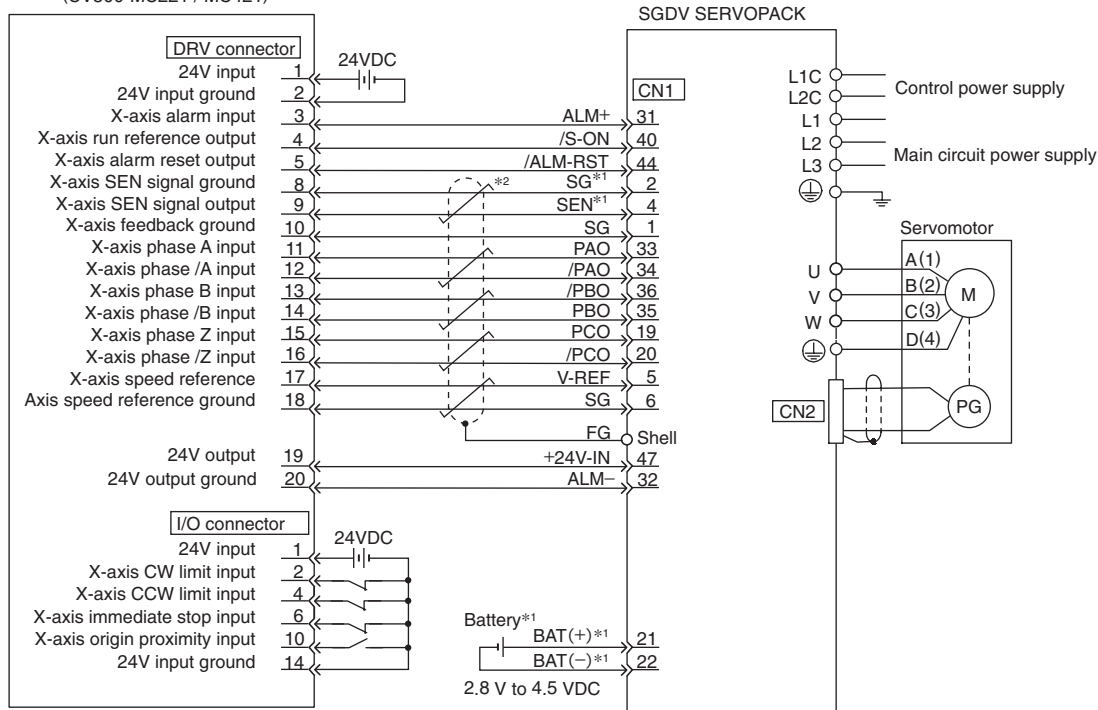

*1: Use a battery when using an absolute encoder.

No battery is needed for CN1 (between 21, 22) when using an encoder cable with a battery.

- Battery for CN1 : ER6VC3N (3.6 V, 2000 mA)
- Battery for battery unit : JUSP-BA01 (3.6 V, 1000 mA)

*2:  represents twisted-pair wires.

- Notes:
- 1 Only signals applicable to OMRON's MC unit and Yaskawa's SGDV SERVOPACK are shown in the diagram.
 - 2 The main circuit power supply is a three-phase 200 VAC SERVOPACK input in the example.
 - 3 Note that incorrect connection will cause damage to the MC unit and SERVOPACK.
Take particular care to wire correctly.
 - 4 Open the signal lines not to be used.
 - 5 The above connection diagram shows only X-axis connection. When using another axes, make connection to the SERVOPACK in the same way.
 - 6 The normally closed (N.C.) input terminals not to be used at the motion control unit I/O connector section must be short-circuited at the connector.
 - 7 Make the setting so that the servo can be turned ON/OFF by the /S-ON signal.
 - 8 The SERVOPACK has a built-in safety function to prevent anyone in the vicinity from being injured by unexpected motion. But, in order to use the function, the circuit for CN8 is required to be configured. When not using the function, use SERVOPACKs with the Safe Japan Connector connected.

Example of Connection to OMRON's Position Control Unit

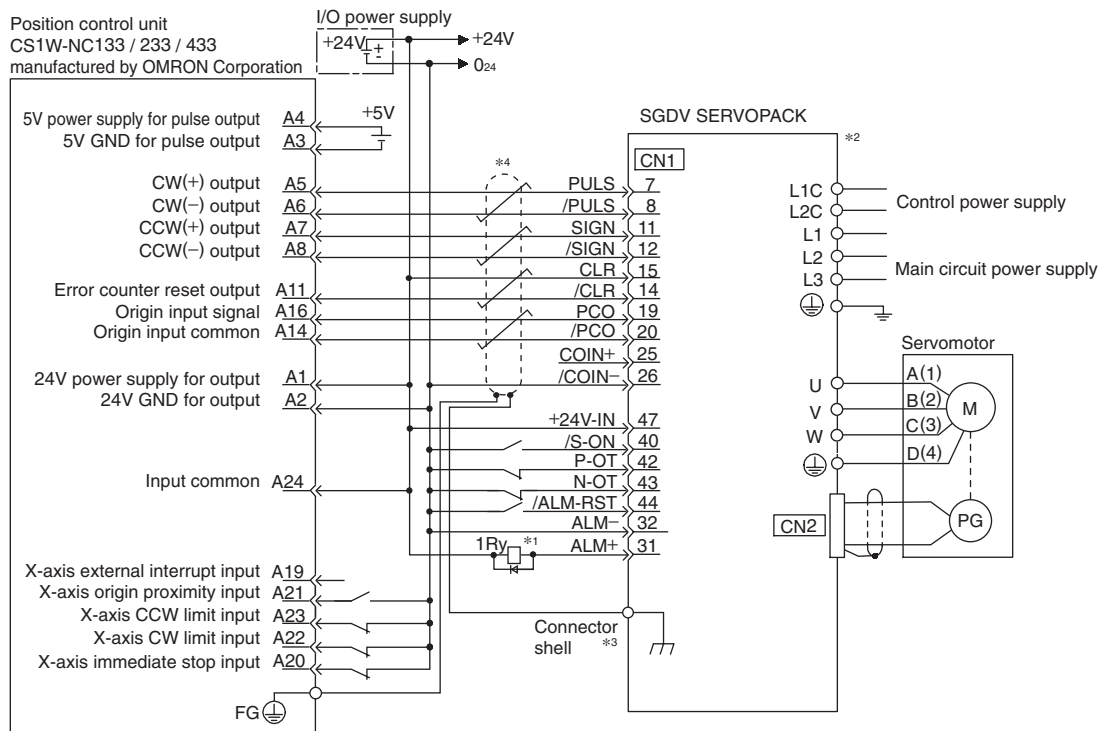

*1: The ALM signal is output for about five seconds after the power is turned ON. Take this into consideration when designing the power ON sequence. The ALM signal actuates the alarm detection relay "1Ry" to stop the main circuit power supply to the SERVOPACK.

*2: Set parameter Pn200.0 = 1.

*3: Connect the shield wire to the connector shell.

*4:  represents twisted-pair wires.

Notes: 1 Only signals applicable to OMRON's MC unit and Yaskawa's SGDV SERVOPACK are shown in the diagram.

2 The SERVOPACK has a built-in safety function to prevent anyone in the vicinity from being injured by unexpected motion. But, in order to use the function, the circuit for CN8 is required to be configured. When not using the function, use SERVOPACKs with the Safe Japan Connector connected.

Example of Connection to Mitsubishi's AD72 Positioning Unit (SERVOPACK in Speed Control)

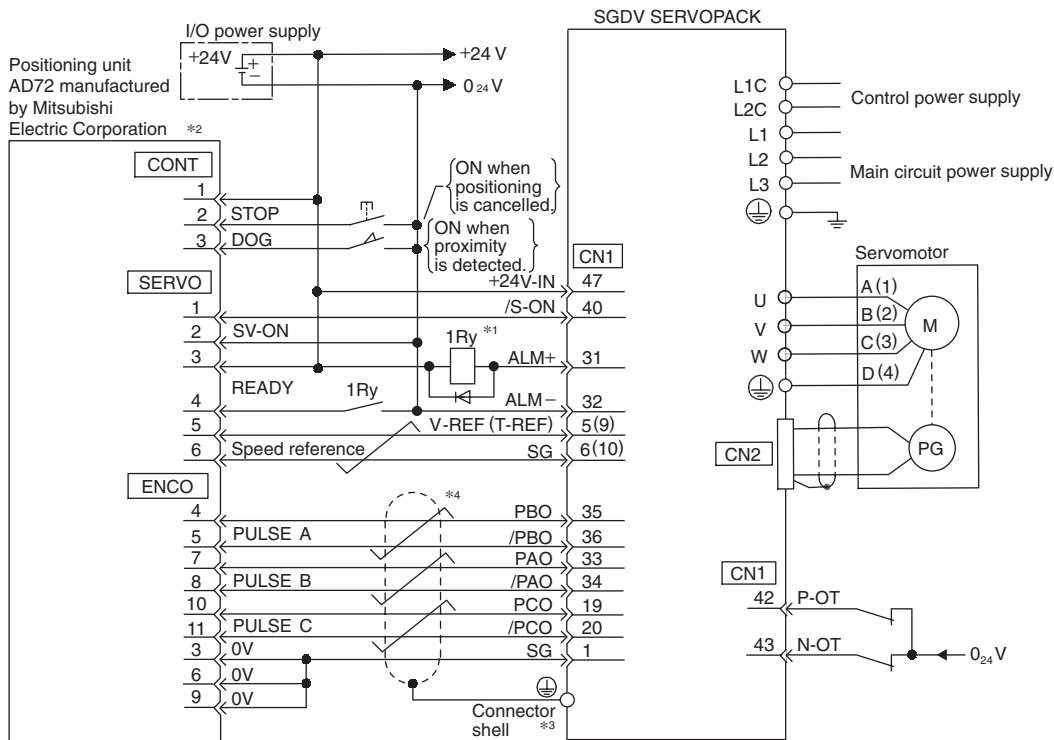

*1: The ALM signal is output for about five seconds after the power is turned ON. Take this into consideration when designing the power ON sequence. The ALM signal actuates the alarm detection relay "1Ry" to stop the main circuit power supply to the SERVOPACK.

*2: Pin numbers are the same both for X-axis and Y-axis.

*3: Connect the connector wire to the connector shell.

*4:  represents twisted-pair wires.

Notes: 1 Only signals applicable to Mitsubishi's AD72 positioning unit and Yaskawa's SGD SERVOPACK are shown in the diagram.

2 The SERVOPACK has a built-in safety function to prevent anyone in the vicinity from being injured by unexpected motion. But, in order to use the function, the circuit for CN8 is required to be configured. When not using the function, use SERVOPACKs with the Safe Japan Connector connected.

Example of Connection to Mitsubishi's AD75 Positioning Unit (SERVOPACK in Position Control)

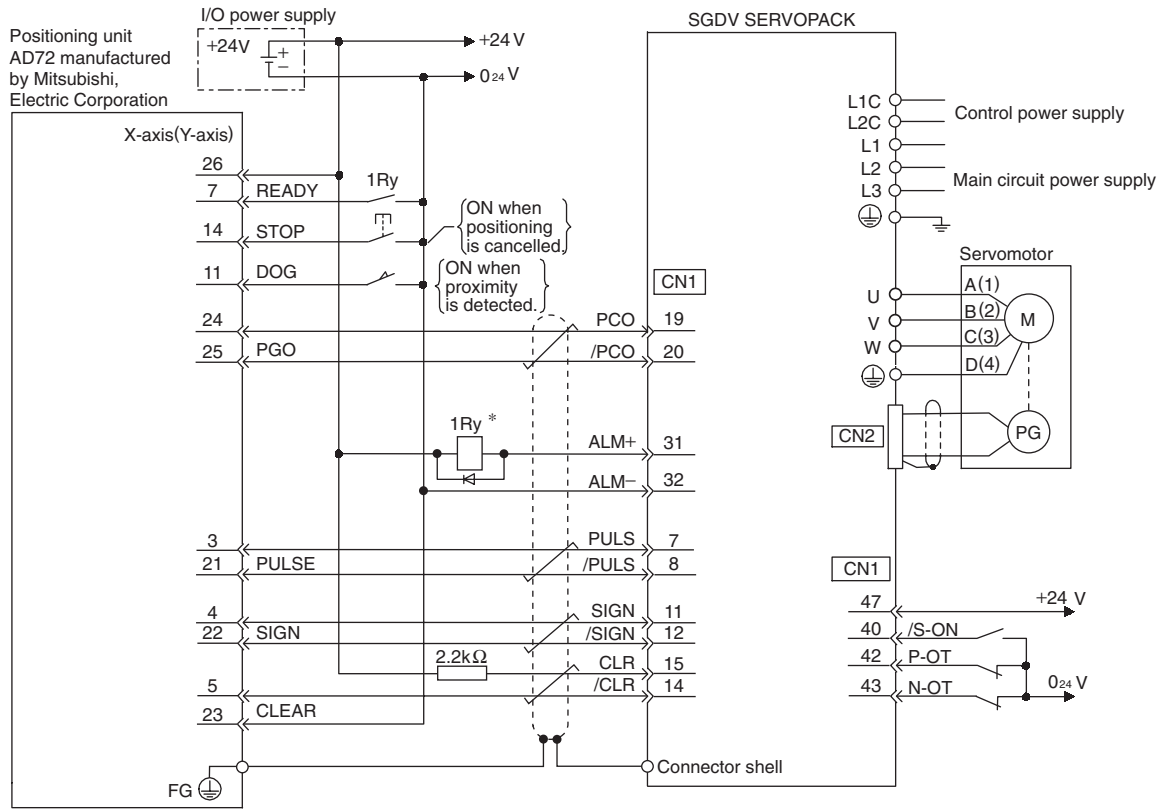

*: The ALM signal is output for about five seconds when the power is turned ON. Take this into consideration when designing the power ON sequence. The ALM signal actuates the alarm detection relay "1Ry" to stop the main circuit power supply to the SERVOPACK.

- Notes: 1 Only signals applicable to Mitsubishi's AD75 positioning unit and Yaskawa's SGD SERVOPACK are shown in the diagram.
- 2 The SERVOPACK has a built-in safety function to prevent anyone in the vicinity from being injured by unexpected motion. But, in order to use the function, the circuit for CN8 is required to be configured. When not using the function, use SERVOPACKs with the Safe Japan Connector connected.

Σ-V SERIES PRODUCT CATALOG

IRUMA BUSINESS CENTER (SOLUTION CENTER)

480, Kamifujisawa, Iruma, Saitama 358-8555, Japan
Phone 81-4-2962-5696 Fax 81-4-2962-6138

YASKAWA ELECTRIC AMERICA, INC.

2121 Norman Drive South, Waukegan, IL 60085, U.S.A.
Phone 1-847-887-7000 Fax 1-847-887-7370

YASKAWA ELÉTRICO DO BRASIL COMÉRCIO LTD.A.

Avenida Fagundes Filho, 620 Bairro Saude-Sao Paulo-SP, Brazil CEP: 04304-000
Phone 55-11-5071-2552 Fax 55-11-5581-8795

YASKAWA ELECTRIC EUROPE GmbH

Am Kronberger Hang 2, 65824 Schwalbach, Germany
Phone 49-6196-569-300 Fax 49-6196-569-312

YASKAWA ELECTRIC UK LTD.

1 Hunt Hill Orchardton Woods Cumbernauld, G68 9LF, United Kingdom
Phone 44-1236-735000 Fax 44-1236-458182

YASKAWA ELECTRIC KOREA CORPORATION

7F, Doore Bldg. 24, Yeoido-dong, Youngdungpo-Ku, Seoul 150-877, Korea
Phone 82-2-784-7844 Fax 82-2-784-8495

YASKAWA ELECTRIC (SINGAPORE) PTE. LTD.

151 Lorong Chuan, #04-01, New Tech Park 556741, Singapore
Phone 65-6282-3003 Fax 65-6289-3003

YASKAWA ELECTRIC (SHANGHAI) CO., LTD.

No.18 Xizang Zhong Road. Room 1702-1707, Harbour Ring Plaza Shanghai 200001, China
Phone 86-21-5385-2200 Fax 86-21-5385-3299

YASKAWA ELECTRIC (SHANGHAI) CO., LTD. BEIJING OFFICE

Room 1011A, Tower W3 Oriental Plaza, No.1 East Chang An Ave.,
Dong Cheng District, Beijing 100738, China
Phone 86-10-8518-4086 Fax 86-10-8518-4082

YASKAWA ELECTRIC TAIWAN CORPORATION

9F, 16, Nanking E. Rd., Sec. 3, Taipei, Taiwan
Phone 886-2-2502-5003 Fax 886-2-2505-1280



YASKAWA ELECTRIC CORPORATION

YASKAWA

In the event that the end user of this product is to be the military and said product is to be employed in any weapons systems or the manufacture thereof, the export will fall under the relevant regulations as stipulated in the Foreign Exchange and Foreign Trade Regulations. Therefore, be sure to follow all procedures and submit all relevant documentation according to any and all rules, regulations and laws that may apply.

Specifications are subject to change without notice for ongoing product modifications and improvements.

© 2007 YASKAWA ELECTRIC CORPORATION. All rights reserved.

LITERATURE NO. KAEP S800000 42A

Printed in Japan June 2007 07-6

05-7®