



GENERAL CATALOGUE 2011

Motion & Drives



GENERAL CATALOGUE 2011

Motion & Drives

www.omron-industrial.com

Note:

Although we do strive for perfection, Omron Europe BV and/or its subsidiary and affiliated companies do not warrant or make any representations regarding the correctness or completeness of information described in this catalogue. Product information in this catalogue is provided 'as is' without warranty of any kind, either express or implied, including, but not limited to, the implied warranties of merchantability, fitness for a particular purpose, or non-infringement. In a jurisdiction where the exclusion of implied warranties is not valid, the exclusion shall be deemed to be replaced by such valid exclusion, which most closely matches the intent and purpose of the original exclusion. Omron Europe BV and/or its subsidiary and affiliated companies reserve the right to make any changes to the products, their specifications, data at its sole discretion at any time without prior notice. The material contained in this catalogue may be out of date and Omron Europe BV and/or its subsidiary and affiliated companies make no commitment to update such material.

Content



Machine Automation Solutions

This catalogue has been created to help you to select the correct machine automation solution for your application. Specifically created based on customer needs, our new motion controllers, servo drives and frequency inverters have been developed to enable you to build machines that are faster, more flexible and completely reliable. As well as high product performance and reliability, Omron provides easy product integration to create completely flexible machine solutions.

The Motion & Drives catalogue 2011 introduces EtherCAT as a single machine network, benefitting from a standard Ethernet network with high synchronisation accuracy between devices. Based on proven quality products and with over 50 years experience in machine automation, Omron offers a wide range of EtherCAT products that includes motion controllers, servo systems, frequency inverters, vision systems and distributed I/O modules.

This extensive product range is complemented by our new series of optimised linear motors and SCARA robots. Omron offers linear motor components or entire customised linear systems. The SCARA robot series is specifically designed for Pick & Place applications to simplify your machines and reduce manufacturing times.

Omron also offers a larger product range that you can discover in the attached DVD.

For more information on Omron's machine automation solutions, please visit our Scalable Machine Automation mini-site at scalablemachine.info

002	Omron presence
003	Featured products
004	Scalable Machine Automation
006	Omron competence
008	Product reliability and service
010	Product overview
012	Omron products
020	Case studies
021	Catalogue content

OMRON PRESENCE



Omron Industrial Automation

As part of the Omron Corporation, Omron Industrial Automation is a global manufacturer of technologically advanced products and a leading provider of application expertise. You'll find our Industrial Automation technologies in factories and machines all over the world.

Omron Industrial Automation Europe

In Europe we have maintained a leading position in machine and industrial automation for over 30 years. Omron provides global resources to customers in all European countries, including development and manufacturing facilities.

Omron – a global company that refuses to be big

'A global company that refuses to be BIG' is the Omron culture that focuses on the idea of being close to the customer. We are global but never BIG, confirming that Omron will always be easy and flexible to deal with. Our field sales engineers and field application engineers work together to offer solutions and support at every stage of your application.

Omron Industrial Automation Europe

- Over 1,800 employees in 28 European countries
- 50 technical offices
- 8 Automation Competence Centres
- Hot-line support in 14 European Languages

FEATURED PRODUCTS

MOTION CONTROLLERS

CJ-Series PLC with EtherCAT

- Position control unit CJ1W-NC with EtherCAT
- Support for to 16 axes and 64 inverter, vision systems and distributed I/O modules

Trajexia with EtherCAT

- Perfect control of 64 axes
- Scalability with EtherCAT masters for 4, 16 and 64 axes
- Supports servos, inverters, vision systems and distributed I/O modules

EtherCAT



Page 35



EtherCAT

Page 25

SERVO SYSTEMS

EtherCAT



Page 59, 83

Accurax G5 servo drive

- High-response frequency of 2 kHz
- EtherCAT and safety built-in
- Rotary and linear motors

Accurax G5 rotary motor

- Power range from 50 W to 15 kW
- IP67 protection and low cogging torque

Page 129



Accurax linear motor solutions

- Linear motor force range from 26.5 to 760 N
- Ironless and iron-core motor types available
- Wide range of over 100 standard linear motor axes

Page 157,173



FREQUENCY INVERTERS

MX2 inverter

- 200% starting torque
- IM & PM motor control
- Positioning functionality and logic programming built-in
- EtherCAT option board

EtherCAT



Page 225

INDUSTRIAL ROBOTS

SCARA robots

- Wide range of reach and payload for adjustment to your application
- Specific versions as clean-room C10 and Dust-proof & Drip-proof IP65



Page 277

SCALABLE MACHINE AUTOMATION

With over 50,000 buying machine builders world-wide – 10,000 in Europe – and 50 years experience in machine automation, we pride ourselves in helping these companies turn their dreams into reality... world class machines. Because when we say it works, IT WORKS!

This statement embodies our core values of supporting you with competent and experienced people, quality products that work in conditions far beyond their published specifications and always maintaining our commitment to you, the customer.

We are successful because we provide solutions based on our customers needs, whether that solution is used in fixed form through to a highly flexible machine.

We believe this is a solid base to start turning YOUR IDEAS into MACHINES THAT WORK.

LEAN AUTOMATION

Addresses small and compact machines performing one dedicated task. It can fit into stand-alone machines or modules within a larger machine. It's merit lies in its simplicity, compactness and cost performance.

Key features

- Compact, fast and robust PLC control
- Up to 4 axis of point-to-point motion control
- HMI, servo and inverters included
- Remote access to the controller



X-STREAM AUTOMATION

X-Stream Automation is for complete production cell control. It offers the highest machine performance levels based on ONE machine controller, an ultra-fast Ethernet based Fieldbus, an IPC based HMI and the integration of vision and robotics as key elements in the automation solution. Above all, it is about your people and our people engaging in ONE common challenge: creating extreme machines!

STREAM AUTOMATION

Aimed at flexible and high speed continuous automation, it relies on 'all-digital' connectivity across all layers. Essential functions like control, motion, regulation and safety are handled through one software and all devices are accessed via one single point. This integrated approach allows for easy programming and full remote servicing down to field device level.

Key features

- Motion bus: up to 30 axes of motion
- One software for all automation tasks
- Active visualisation with smart functionality for device monitoring and configuration
- Remote access across all the automation layers

Key features

- Up to 64 axis of synchronised motion
- IPC for visualisation and data storage
- SCARA robot and linear motor stages
- 2D and 3D inspection plus fast positioning via Xpectia vision system

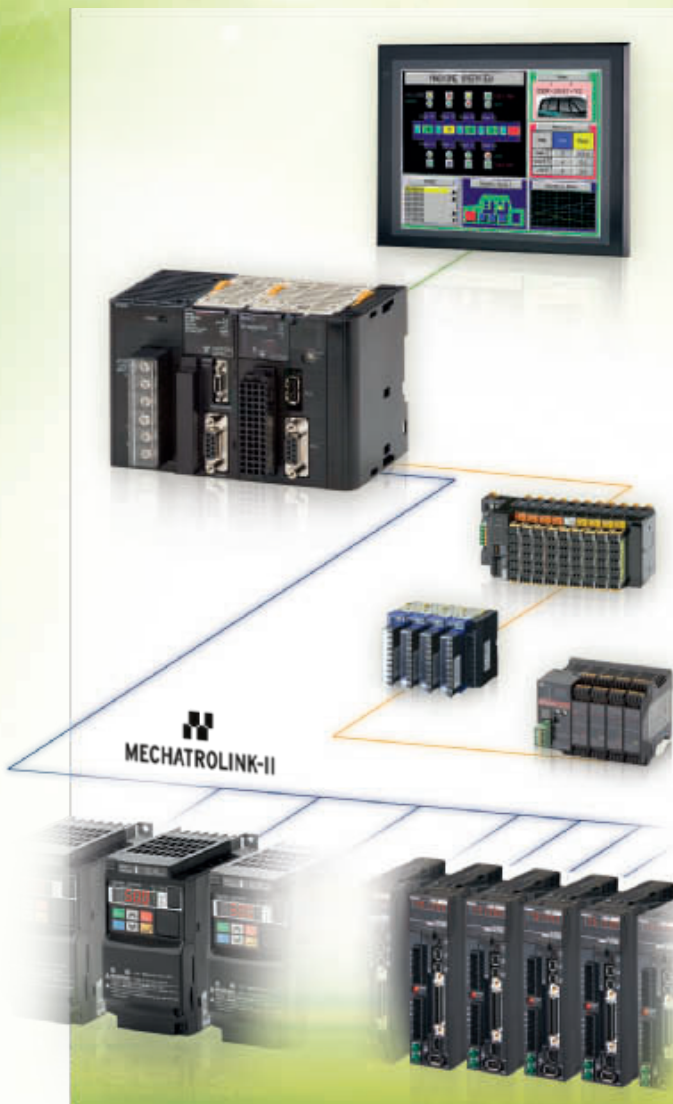

OMRON COMPETENCE

From your first idea, ...to your final machine!

Products and concepts alone are never enough, this is why we will be with you at every stage, helping you to create faster, smarter and more cost effective machines.

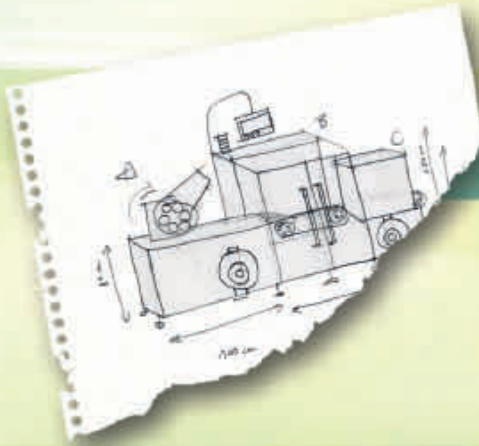

FROM YOUR FIRST IDEA,

COMPETENCE

DESIGN



Our field sales and application engineers will support you to design the best machine solution for your application. They have the experience and competence, and are empowered to make decisions.

PROOF OF CONCEPT



As soon as our involvement starts, an application engineer is appointed to coordinate all of the technical aspects of the project. The primary role is to agree the machine automation architecture, aligned to your technical and business needs.

A proof of concept can be undertaken with our application engineers and product specialists. Our resources include:

- 8 Automation Competence Centres to test and improve your application solution
- 50 local technical offices

...TO YOUR FINAL MACHINE!



CONFIDENCE

DEVELOPMENT



As your development begins a dedicated application engineer will support you to find better functionality for your machine.

PRODUCTION



During production Omron's service offering includes:

- A dedicated customer service member, who will be on hand to support you with all of your logistics issues.
- 2 day product delivery

AFTER SALES SUPPORT



Omron offers regular software upgrades, a rapid repair service and effective global support to your end users:

- 5 day repair door to door
- Global support in 300 offices in 80 countries

PRODUCT RELIABILITY AND SERVICE

Reliability in rugged industrial conditions

Through our extensive experience in motion control across Europe, Omron offers reliable and robust motion & drive products, demonstrated by our low failure rates. The European Repair Centre also offers a 5 day repair, door-to-door, and will ensure minimal downtime in the case of a machine breakdown. First and foremost though, the new motion and drive products are designed and built to provide optimum reliability in rugged industrial conditions.

TECHNOLOGY

10 YEARS OPERATION

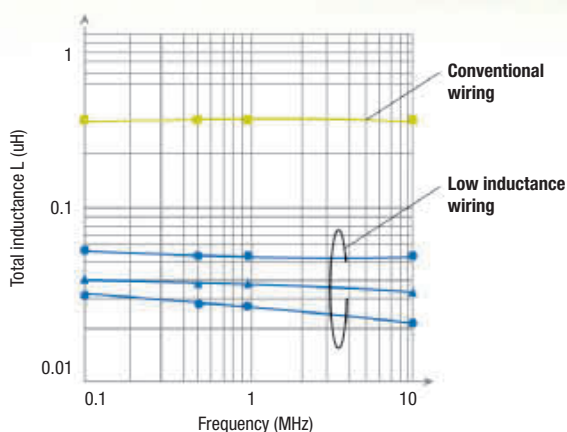

The new inverter series has been designed to guarantee 10 years of continuous operation. The "Low Inductance Power Circuit (LIPC)" design leads to a big reduction in losses in IGBTs and flywheel diodes (SFD). This extends the lifetime of the power components and reduces stress when operating at a high carrier frequency.

IMPROVED MOTOR TECHNOLOGY



Servo motors use split cores to increase the winding density, resulting in the same magnetic flux in less volume. In addition though, Omron use PACK & CLAMP technology, increasing servo motor core density and reducing iron losses by 40%. The stator laminations are packed then simply clamped.



ASSURANCE

PRODUCT SUPPORT

5 DAYS

**EXPRESS REPAIR
AND DELIVERY**

24 HOURS

RESPONSE TIME

3 DAYS

**STANDARD
REPAIR**

















Omron repairs your product with experienced and trained staff, using the latest technology. We will handle and respond to your orders and questions in less than 24 hours.

The ER&SC – European Repair and Service Centre – can repair a product within 3 working days. We also offer a 5-day express repair service for EU-countries that includes the 3 days repair and transportation time.

For high power inverters, a repair engineer from ER&SC or one of its authorized partners will travel to the customer and repair the product on site.

The service centre can also manage case flashing/ software upgrades in order to maintain product compatibility throughout the life of your machine.

PRODUCT OVERVIEW – A WIDE PRODUCT RANGE...

		Drive control method	EtherCAT	MECHATROLINK-II	Analogue output	Pulse train output
Motion controllers	<p>Continuous path control</p> <p>Electronic CAMs</p> <p>Advanced Motion Control</p> <p>Multi-axis synchronization</p>		 <p>Trajexia stand-alone Page 25</p>	 <p>Trajexia stand-alone Page 25</p>	 <p>Trajexia stand-alone Page 25</p>	 <p>NC_4 Page 51</p>
	<p>Point to Point Positioning</p>		 <p>NC_8 Page 35</p>	 <p>NC_71 Page 43</p>		 <p>NCs Page 47</p>
Servo systems	<p>Drive control method</p>		EtherCAT	MECHATROLINK-II	Analogue input	Pulse train input
	<p>Servo drive</p> <p>Up to 15 kW</p> <p>High bandwidth of 2 kHz</p> <p>Safety built-in</p> <p>20 bit encoder</p> <p>Voltage: 230 VAC/400 VAC</p>	 <p>Accurax G5 EtherCAT Page 59, 83</p>	 <p>Up to 5 kW Rotary motors only</p> <p>Accurax G5 ML2 Page 59</p>	 <p>Embedded indexer functionality</p> <p>Accurax G5 Analogue/Pulse Page 59, 83</p>		
	<p>Rotary motor</p> <p>Up to 15 kW</p> <p>IP67 servo motor</p> <p>Voltage: 230 VAC/400 VAC</p>	 <p>Accurax G5 rotary servo motors Page 129</p>				
	<p>Linear motor</p> <p>Ratings from 26.5 to 760 N</p> <p>Ironless and iron-core linear motor types</p> <p>Over 100 standard linear axes</p>	 <p>Accurax Linear motors Page 157</p>		 <p>Accurax Linear motor axes Page 173</p>		
	<p>Servo drive</p> <p>10,000 pulses/17 bit absolute encoder</p> <p>Voltage: 230 VAC</p>	 <p>Absolute encoder</p> <p>G-Series ML2 Page 103</p>				
<p>Rotary motor</p> <p>IP65 servomotor</p> <p>Voltage: 230 VAC</p>	 <p>Flat type</p> <p>G-Series rotary servo motors Page 147</p>					
		 <p>Absolute encoder</p> <p>G-Series Analogue/Pulse Page 103</p>		 <p>Pulse train only 10,000 pulses/rev</p> <p>SmartStep 2 Page 117</p>		

...FOR MACHINE AUTOMATION SOLUTIONS

Frequency inverters

Applications/Market

Crushers
Mills
Mixers
Winders
Cranes
Extruders
Pumps & Fans
Marine (SX model)

Lift
Synchronous/
asynchronous motor
control

Palletisers
Basic positioning
Textile winding
Automatic door
control (programming)
Packaging
PM motor control in
open loop

Conveyors
Low Power Pumps & Fans



RX
Page 191



SX (690 V)
Page 261



LX ⇄

LX
Page 209



SX (400 V)
Page 249

IP54



MX2
Page 225



JX
Page 239

Up to 7,5 kW
200 VAC / 400 VAC
V/F control

Up to 15 kW
200 VAC / 400 VAC
V/F control
Sensorless vector
control

Up to 37 kW
400 VAC
V/F control
Sensorless vector
control
Closed loop control

Up to 132 kW
200 VAC / 400 VAC
V/F control
Sensorless vector
control
Closed loop control

Up to 800/1,000 kW
400 VAC/690 VAC
V/F control
Sensorless vector
control
Closed loop control

trajexia TOTAL FREEDOM IN MOTION CONTROL

Trajexia with EtherCAT

The stand-alone Trajexia controller TJ2-MC64 together with an EtherCAT Master TJ2-ECT provides a significant improvement in machine performance and accuracy allowing you to run your machines faster. Controlling all 64 axes with a minimum system cycle time and with the use of 64 bit integers, Trajexia TJ2 ensures the fastest operation at the highest accuracy. It is ideal for highly demanding applications, such as those involved in packaging, printing and textile machines. As you would expect, a wide choice of best-in-class actuators are available to meet your needs in compact design, performance and reliability.



Trajexia stand-alone

Perfect motion control

At the heart of Trajexia lies a multi-tasking motion controller specifically designed to meet the most demanding motion tasks such as e-cam, e-gearbox and registration control and interpolation... with best performance and all via simple motion commands.

EtherCAT technology

EtherCAT is an Ethernet-based network optimised for machine automation. Providing high synchronisation accuracy between servos.

A high synchronisation accuracy is achieved by the use of distributed clocks. The distributed clocks are adjusted by each slave enabling the axes to be synchronised with a jitter of less than 1 μ s.

EtherCAT uses a standard 100BASE-TX Ethernet cable (CAT-5 or above) and complies with IEEE 802.3. Up to 100 m distances between devices is allowed and, without the use of switches, simplifies network installation.

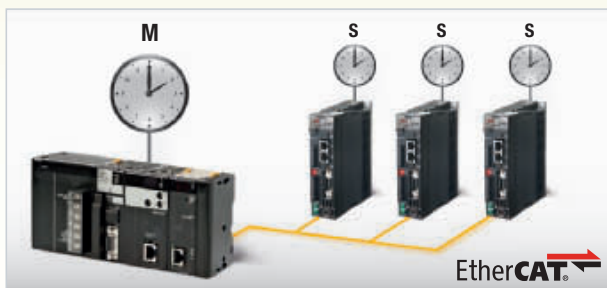

Precise axes synchronisation by exact adjustment of distributed clocks

Trajexia features:

- Perfect control of 64 axes
- Scalability – free choice between 4, 16, 30 or 64 axes
- Multi-tasking controller capable of running up to 22 tasks simultaneously
- Support for servos, inverters, vision systems and distributed I/O modules in a single EtherCAT network
- Each axis can be programmed using linear, circular, helical or spherical interpolation, electronic CAMs and gears
- Open communication – Modbus, TELNET, FINS and EtherNet/IP built-in, PROFIBUS-DP, DeviceNet and CANopen options

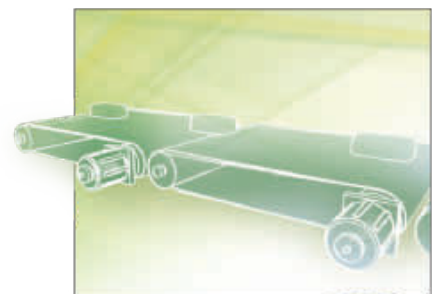

Main conveyor

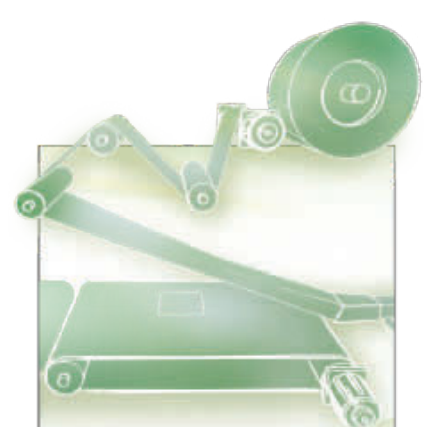
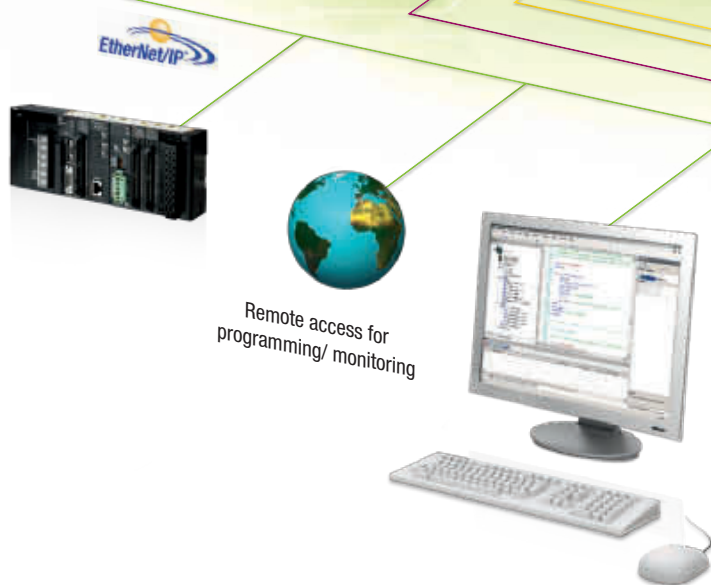
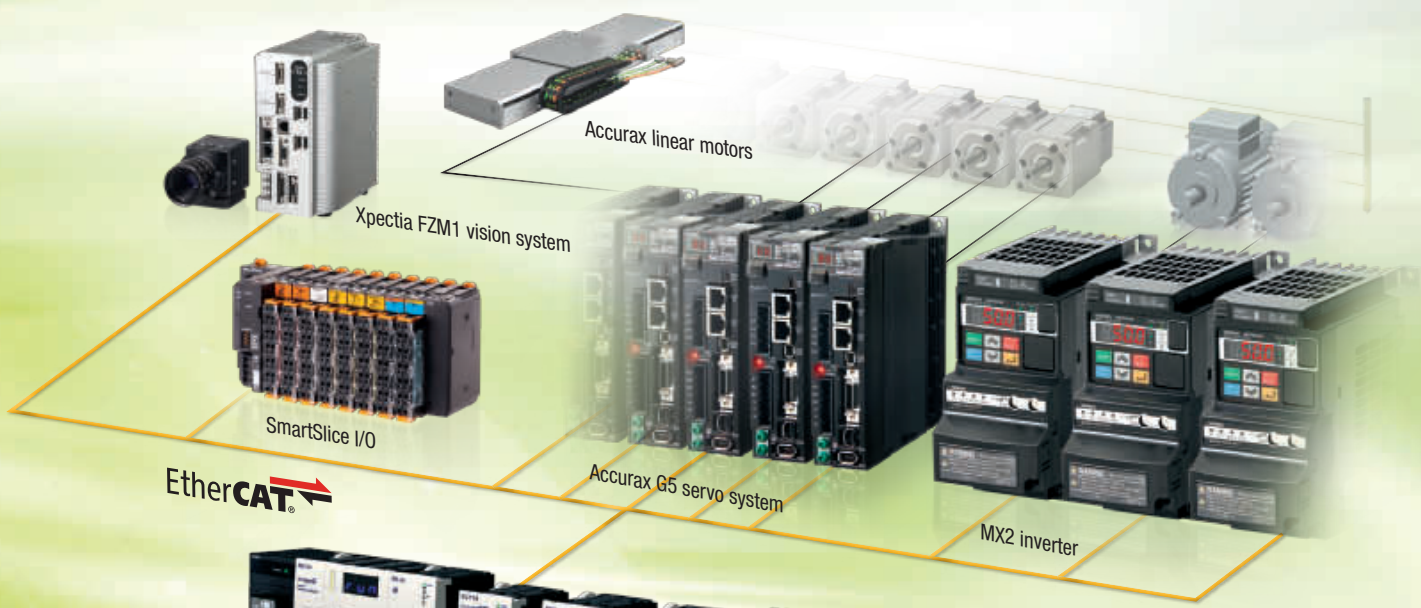

ACCURAX G5 SERVO SYSTEM

At the heart of every great machine

Great machines are born from a perfect match between control and mechanics. Accurax G5 gives you the extra edge to build more accurate, faster, smaller and safer machines. You will benefit from an almost 25% reduction in motor weight, and gain 50% cabinet space. You will achieve sub micron precision and ms settling time. Some might call it perfection, we just call it tireless innovation to help you build great machines.

EtherCAT 

EtherCAT connectivity

- Compliant with CoE —CiA402 Drive Profile—
- Cyclic synchronous Position, Velocity and Torque modes
- Embedded Gear Ratio, Homing and Profile Position mode
- Distributed clock to ensure high precision synchronisation

Rugged and smart design

- IP67 motor and connectors
- No flying leads
- 5G vibration resistance

40% reduction in motor cogging

- Use of 10 pole motors
- Improved technology to minimize the encoder non-linear errors

8 times higher resolution

- 20 bit encoder
- Faster processor

25% lighter and 15% smaller

- Patented new stator PACK & CLAMP technology
- 40% reduction in iron losses, 45% smaller encoder

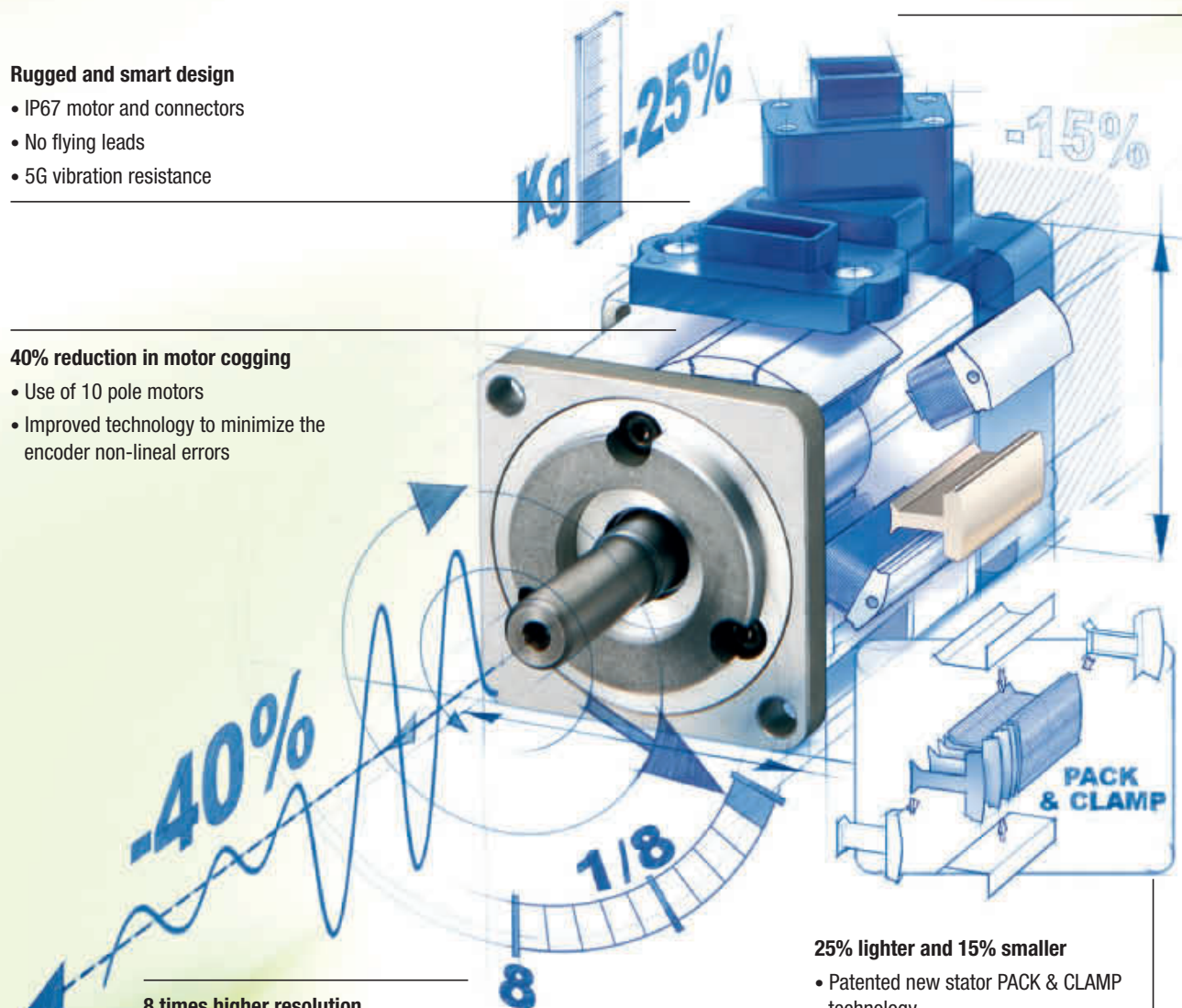

Up to 50% cabinet size reduction

- Up to 40% smaller drive
- Extra 10% space saving thanks to side by side mounting

Safety conformance

- PL-d according ISO13849-1:2008
- STO: IEC61800-5-2:2007
- SIL2 according to EN61508:2001
- Cat.3: EN954-1:1996



Fast and accurate

- 5 times faster settling time -0~2 ms
- 2 kHz speed response
- Torque feed forward reduces following error

-50%

Settling time

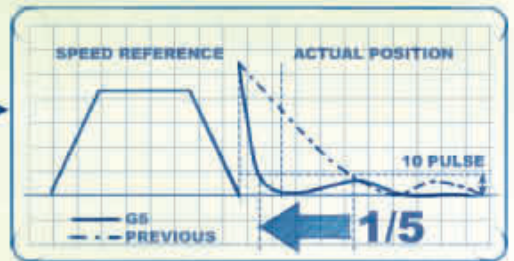

Speed response

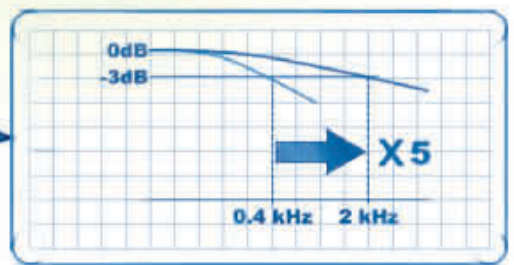

Torque feed forward

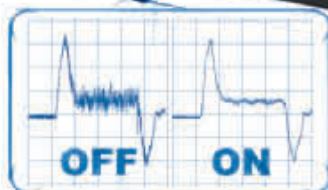
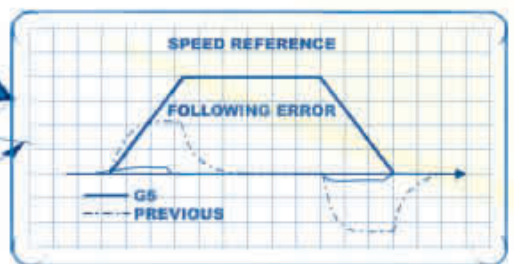

Vibration suppression

Load vibration suppression

- Up to 4 preset frequencies
- Setting frequency from 1 to 200 Hz

100,000 hr operation in rugged industrial conditions

- No fan below 1 kW
- Long life capacitors



MX2 INVERTER – BORN TO DRIVE MACHINES

200% starting torque

Harmonised motor and machine control

The MX2 is specifically designed to drive machines. It has been developed to harmonise advanced motor and machine control. Thanks to its advanced design and algorithms the MX2 provides smooth control down to zero speed, plus precise operation for fast cyclic operations and torque control capability in open loop. The MX2 also gives you comprehensive functionality for machine control such as positioning, speed synchronisation and logic programming. The MX2 is fully integrated within the Omron smart automation platform. The MX2 is the child of a true leader in machine automation.

Torque control in open loop

Special motors

One parameter auto-tuning

100% CONTROL...

High starting torque and torque control capability in open loop mode gives you full control of your machine dynamics and performance. Options for all of the major fieldbus systems and a 24 VDC external supply keeps you in full control of your machine operation.

...0% RISK

Safety is embedded in the MX2, according to ISO 13849-1, Cat 3, with two safety inputs and External Device Monitoring (EDM) output. No external contactors on the motor side are required, meaning simpler wiring for the user.

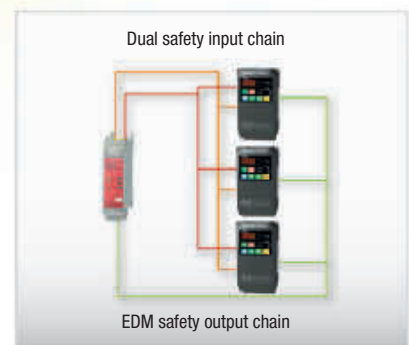
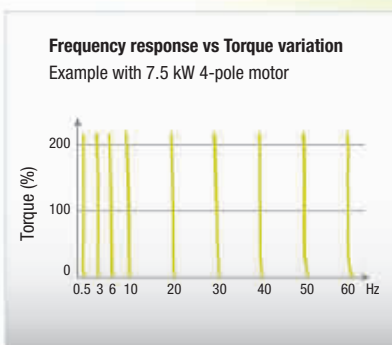

Torque master

The MX2 delivers 200% starting torque near stand-still (0.5 Hz) and can operate in torque control in open loop mode. This allows the MX2 to be used in applications where closed loop AC vector drives were previously used.

Easy network integration

Built-in RS485 Modbus communications and standard industrial networks, such as EtherCAT (compliant with CoE – CiA402 Drive profile –), MECHATROLINK-II, DeviceNet, Profibus or CompoNet as options.

Safety embedded according to ISO 13849-1, Cat 3 and EDM monitoring output

An External Device Monitoring (EDM) output confirms the safety status of the inverter, saving you the cost and wiring of external devices. The safety inputs can be linked from one inverter to another without additional safety relays.

MOTOR CONTROL

- Near stand-still operation (0.5 Hz)
- Smooth control of high inertia loads
- Control of fast cyclic loads

- Ideal for low to medium torque applications
- Can replace a flux vector or servo drive in suitable systems

- Permanent magnet motors
- High speed motors up to 1,000 Hz

- Just by entering the kW rating of the motor the MX2 gives you smooth and safe operation



MACHINE CONTROL

Safety inside

- Conforms to safety norm ISO-13849 CAT3 performance level PLD
- 2 Safety inputs
- External device monitoring (EDM)

Logic programming

- Flow chart programming
- Text editor
- Intuitive – up to 5 tasks in parallel

Positioning

- Up to 8 pre-set positions with "Homing"
- Speed synchronisation

Integrated in the Omron Smart Automation

- CX-Drive programming tool connected via integrated USB port on MX2.
- Modbus RS485 built-in
- Option units for EtherCAT, Profibus, DeviceNet, ML-II and more...



POSITION AND RUN!

The MX2 is a drive and position controller in one, ideal for modular machines where moderate positional accuracy is required. Speed synchronisation is also possible, with no additional programming required.

PROGRAM AND PLAY!

The MX2 gives you the power to create smart solutions using PLC functionality, as standard. Via an intuitive flow chart programming tool, you can create programs with up to 1000 lines of code and with 5 tasks running in parallel.



Speed synchronisation

With no external hardware required, and via standard parameter settings, speed synchronisation can be achieved. The MX2 will act as a speed follower to an external pulse generator/encoder signal up to 32 kHz.

Positioning functionality

Specially developed application functionality enables the MX2 to solve simple positioning tasks without the need for an external controller. Up to 8 positions, plus home, can be selected by the user, and furthermore, the MX2 can be switched between speed and position mode.

Free to program

- Intuitive and user friendly flow chart programming
- Integrated in CX-Drive
- Up to 1000 lines in a program
- 5 tasks can run in parallel

ACCURAX LINEAR MOTORS

New products with optimised efficiency

Ironless linear motors

- Compact, efficient design
- Excellent force-to-weight ratio
- No latching force
- Optional digital Hall-sensor and connectors
- Temperature sensors included

Iron-core linear motors

- Compact and flat design
- Optimum ratio between force and volume
- Weight-optimized magnet track
- Optional digital hall-sensor and connectors
- Temperature sensors included

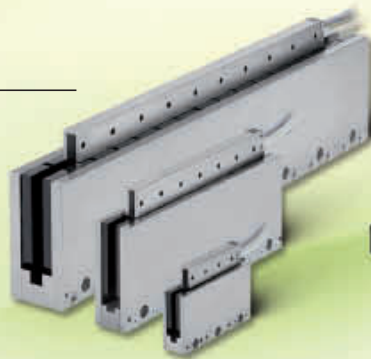

Linear motor axes

- Low moving mass to ensure a high degree of dynamic control
- Optimized stroke/product length ratio
- Compact and efficiency oriented design
- 5 m/s maximum speed
- 1 μm repeatability

From components to a system solution

Omron offers linear motor solutions, from components to entire systems, from a single source. Over many years, sectors such as the semiconductor, photovoltaic, pharmaceutical and packaging industries have come to value Omron as an expert supplier and partner in this field. We are pleased to advise and support you with our experience and expertise, starting from the initial idea, through

design to optimum integration in your machine and system concept. Omron's internal 'Mechatronic' and 'Application' competence teams work hand-in-hand to produce solutions in customisation projects. The customer and his application are always our focus and we work in dialogue with him to produce sustainable solutions that are perfectly tailored to his needs.



The X/Y tables systems are adapted and optimised for the required application, reducing construction time.



Precision measurement with laser interferometer for quality assurance to create the data for stage mapping.

INDUSTRIAL ROBOTS

SCARA robots for industrial applications

SCARA robots

- Higher reliability (no belts in XG series, no electronic parts in movement)
- Higher precision and speed
- Minimum maintenance
- Higher rigidity
- Easier to use
- Very compact design
- Multiple connectivity options
- Integrated vision and conveyor tracking functions



Wide range providing the performance you need...

Our SCARA robots are available in versions with maximum payload capacity from 1 kg up to 50 kg, and with arm reach from 120 mm to 1,200 mm, allowing for precise adjustment of the robot to your application. Special versions, such as clean-room and dust-proof type are optimised for use in critical environments in the food and pharmaceutical industries.

High reliability and minimum maintenance

Key features of the new robots are high reliability and minimal maintenance requirements. The XG-series models in particular, incorporate new technology that completely eliminates drive belts and the need to mount electrical and electronic components on moving parts of the robot. This allows them to consistently deliver exceptional levels of performance and reliability in even the most demanding of applications

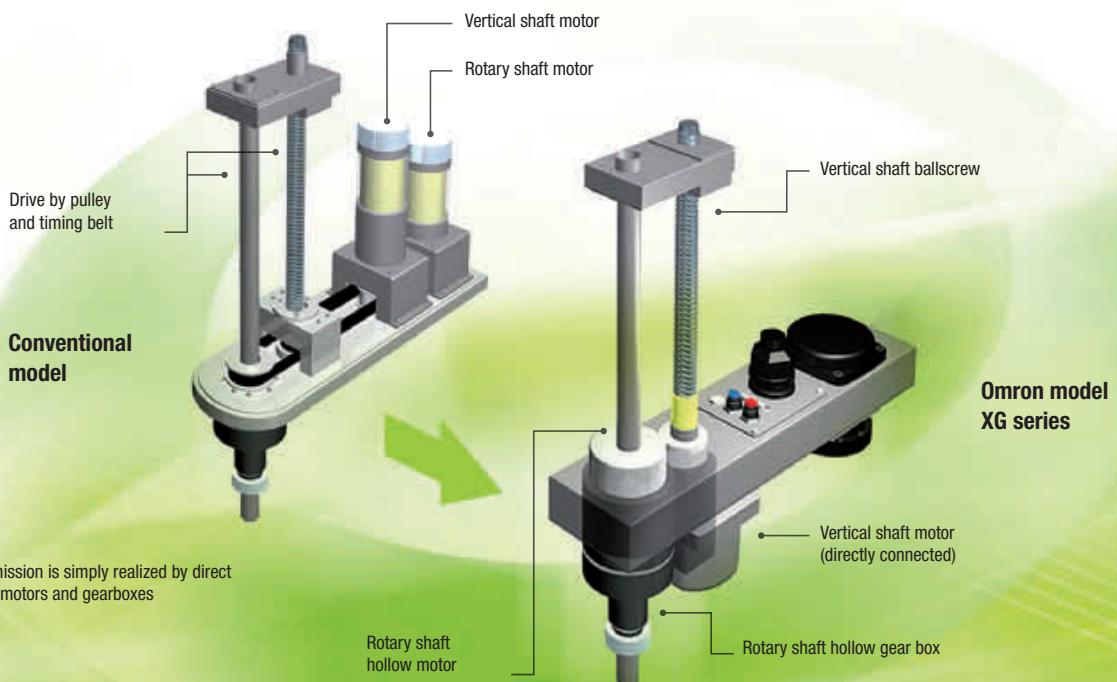

CASE STUDIES

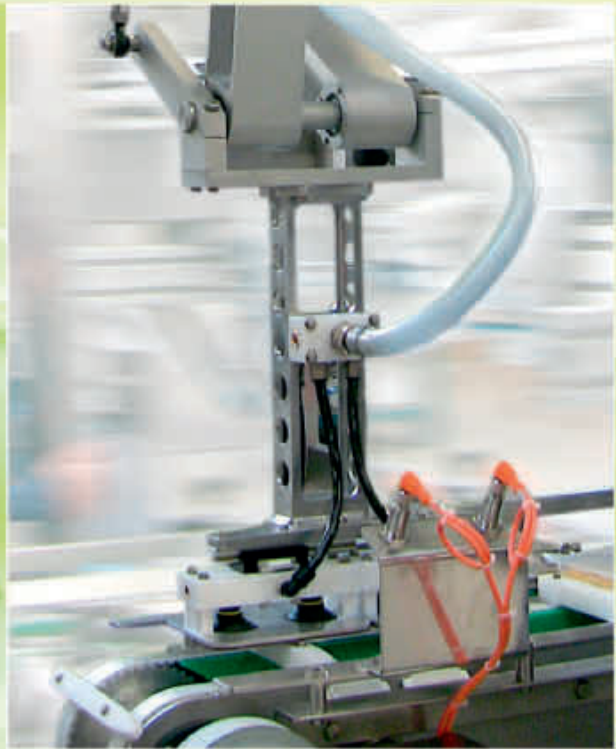

Delta-2 Robot – Pick & Place controlled by Trajexia

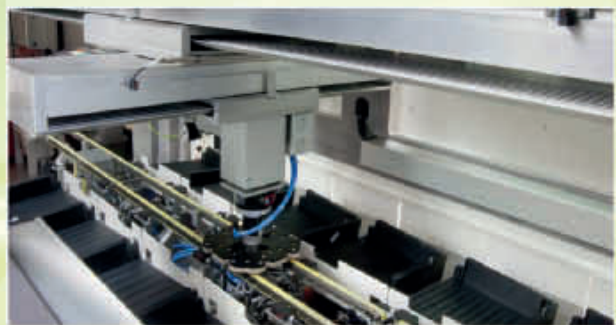

Linear motor axis system for high speed PV wafer handling



Pick & place with 2 SCARA robots



Flow pack machine controlled by Trajexia

Main content

Motion controllers 22

Selection table		24
Controllers		
Control via EtherCAT	Trajexia stand-alone	25
	CJ1W-NC□8□	35
Control via MECHATROLINK	Trajexia stand-alone	25
	Trajexia-PLC CJ1W-MC□72	39
	CJ1W-NC□71	43
Control via pulses	CJ1W-NC□□3	47
	CJ1W-NC□□4	51

AC Servo systems 54

Selection table		56
Servo drives	Accurax G5 rotary drive	59
	Accurax G5 linear drive	83
	G-Series	103
	SmartStep 2	117
Rotary servo motors	Accurax G5	129
	G-Series	147
Linear servo motors	Accurax linear motor	157
	Accurax linear motor axis	173

Frequency inverters 188

Selection table		190
Inverters	RX	191
	LX	209
	MX2	225
	JX	239
	SX (400V)	249
	SX (690 V)	261

Industrial robots 274

Selection table		276
Robots	SCARA robot series	277

Technical information 331

Technical documentation 335

Index 337

Motion controllers

AC Servo systems

Frequency inverters

Industrial robots

Technical information

Technical documentation

Index

Motion controllers

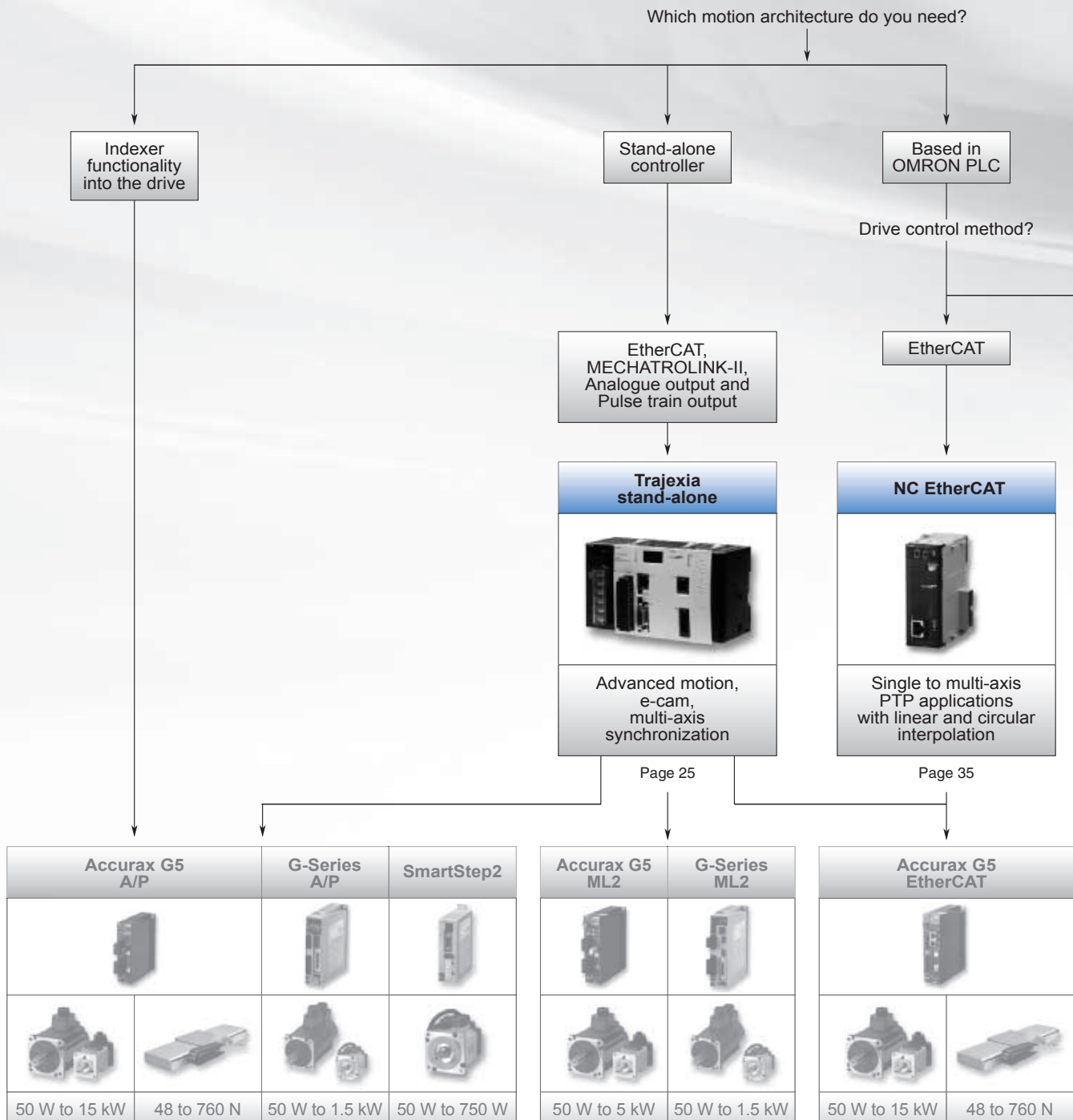
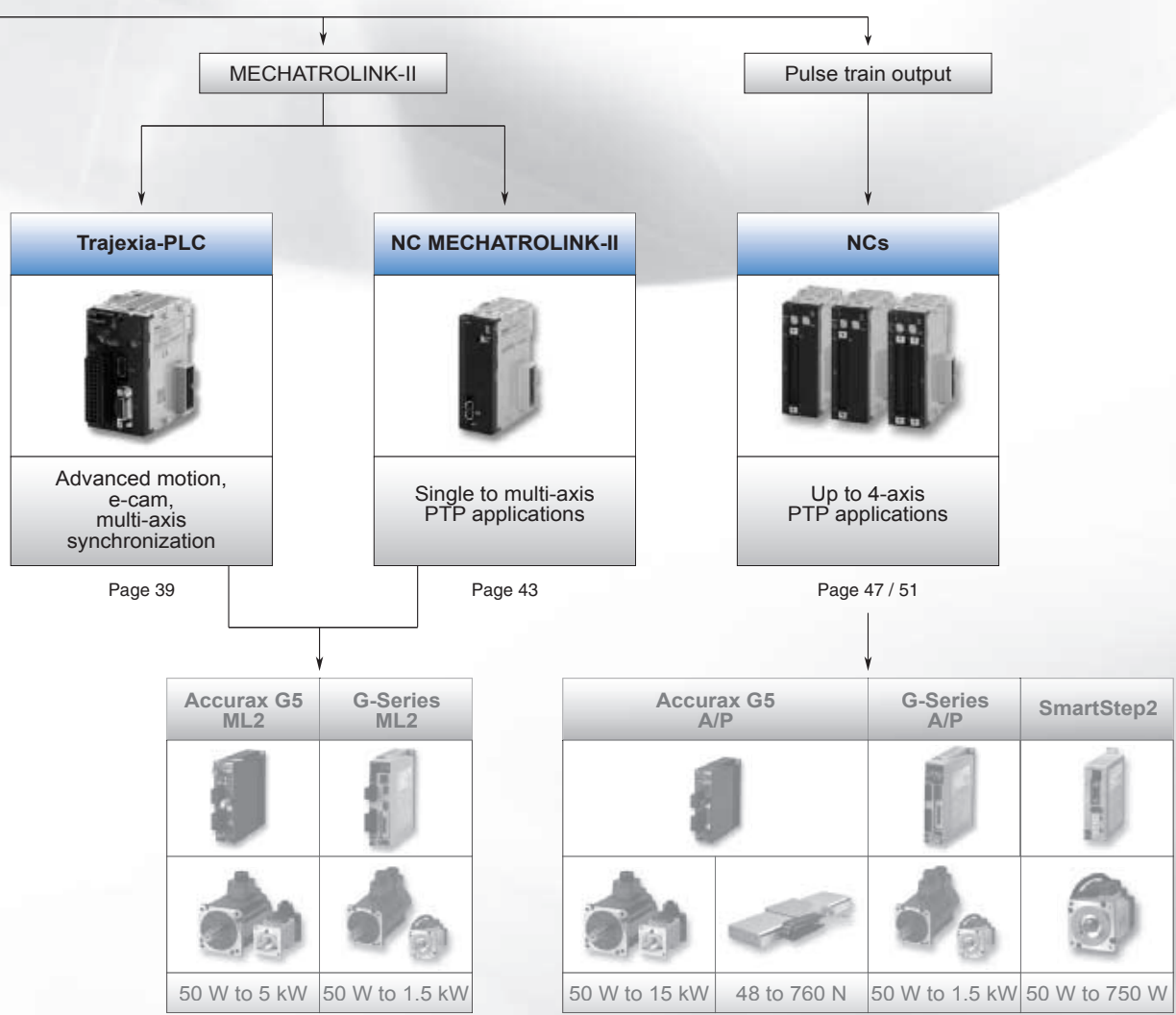







Table of contents

Selection table		24
Controllers		
Control via EtherCAT	Trajexia stand-alone	25
	CJ1W-NC□8□	35
Control via MECHATROLINK	Trajexia stand-alone	25
	Trajexia-PLC CJ1W-MC□72	39
	CJ1W-NC□71	43
Control via pulses	CJ1W-NC□□3	47
	CJ1W-NC□□4	51



Selection table

Motion controllers				
				
Model	Trajexia stand-alone	NC EtherCAT	Trajexia-PLC	NC MECHATROLINK-II
	The advanced stand-alone motion controller	16-axis point-to-point positioning controller	Advanced multi-axes motion controller in a PLC	16-axis point-to-point positioning controller
Axes control method	EtherCAT, MECHATROLINK-II, analogue output and pulse-train output	EtherCAT	MECHATROLINK-II	MECHATROLINK-II
Number of axes	4, 16, 64	2, 4, 8, 16	4, 30	2, 4, 16
Applicable servo drive	Accurax G5 and G-Series	Accurax G5	Accurax G5 and G-Series	Accurax G5 and G-Series
Application	Advanced motion, e-cam, ELS, Phase shift, Registration	From simple PTP to multi axis PTP with linear and circular interpolation	Advanced motion, e-cam, ELS, Phase shift, Registration	From simple PTP to multi axis PTP coordinated systems
Servo control mode	Position, speed and torque	Position, speed and torque	Position, speed and torque	Position, speed and torque
PLC series	Stand-alone motion controller: Serial and Ethernet/IP built-in, PROFIBUS-DP, DeviceNet and CANopen communication options	CJ	CJ	CJ and CS1
Page	25	35	39	43

Motion controllers	
	 
Model	NC□□3 NC□□4
	4-axis point-to-point positioning controller 4-axis point-to-point positioning controller with synchronization
Axes control method	Pulse train output Pulse train output
Number of axes	1, 2, 4 2, 4
Applicable servo drive	SmartStep 2 and Accurax G5 SmartStep 2 and Accurax G5
Application	Point to point applications Point-to-point with complex interpolations
Servo control mode	Open loop position with linear interpolation Open loop position with linear and circular interpolation
PLC series	CJ and CS1 CJ
Page	47 51

Trajexia stand-alone

Trajexia motion controller

Stand-alone advanced motion controller over EtherCAT

- Perfect motion control of up to 64 axes. Scalability with EtherCAT masters for 4, 16 and 64 axes.
- Supports position, speed and torque control
- Multi-tasking controller capable of running up to 22 tasks simultaneously
- Advanced motion control such as linear, circular, helical or spherical interpolation, electronic cams and gearboxes via simple motion commands.
- Control of servos, inverters, vision systems and distributed I/Os over a single EtherCAT network
- Support for EtherNet/IP communications
- Advanced debugging tools including data trace and oscilloscope functions
- Open communication: Serial and EtherNet/IP built-in, PROFIBUS-DP, DeviceNet and CANopen



System configuration

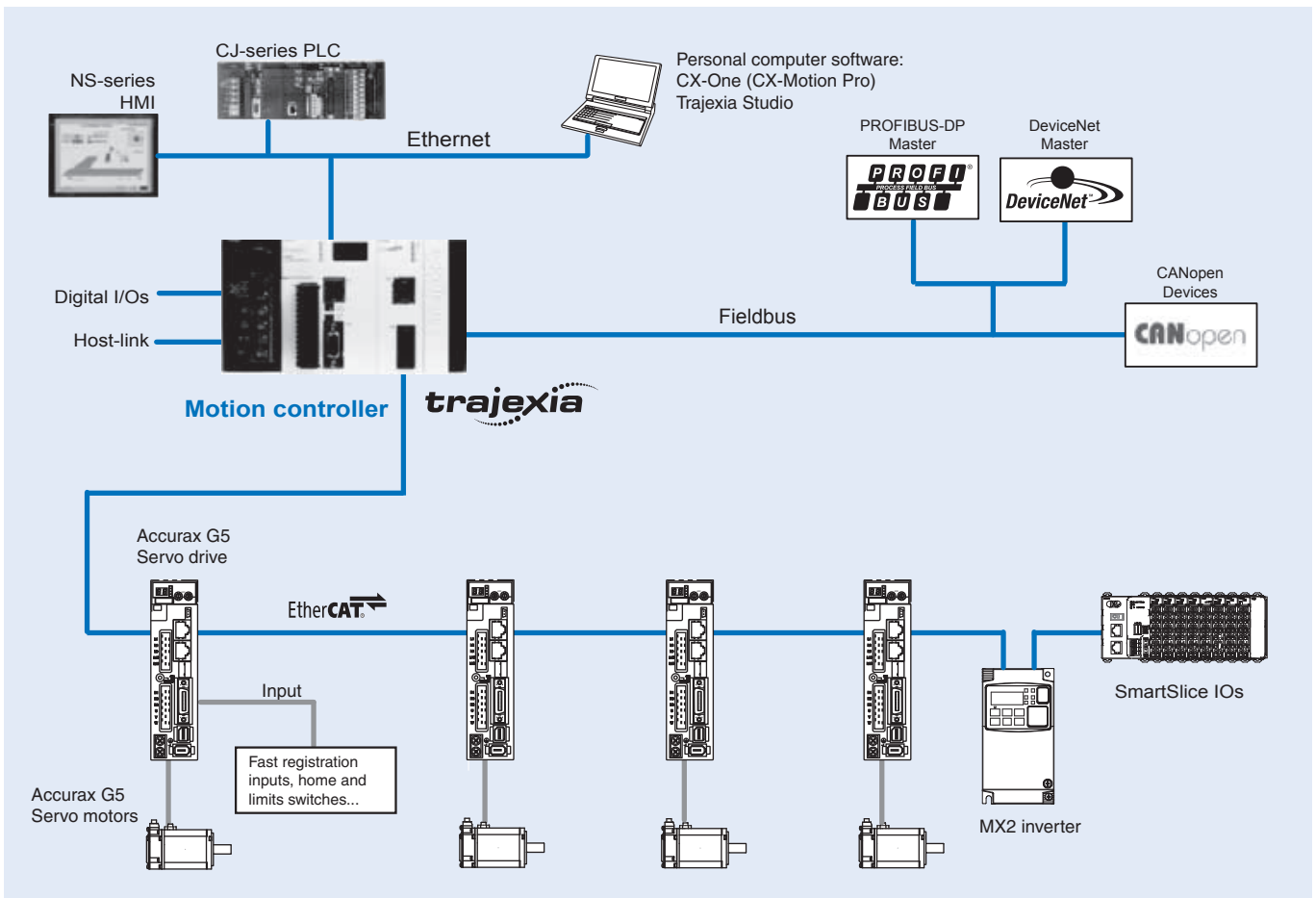

Specifications

Trajexia general specifications

Item	Details
Model	TJ□
Ambient operating temperature	0 to 55°C
Ambient operating humidity	10 to 90%RH
Ambient storage temperature	-20 to 70°C
Ambient storage humidity	90% max. (with no condensation)
Atmosphere	No corrosive gases
Vibration resistance	10 to 57 Hz: (0.075 mm amplitude) 57 to 100 Hz Acceleration: 9,8 m/s ² , in X, Y and Z directions for 80 minutes.
Shock resistance	143 m/s ² , 3 times each X, Y and Z directions.
Insulation resistance	20 MOhm
Dielectric strength	500 Volt
Protective structure	IP20
International standards	CE, EN 61131-2, cULus, Lloyds, RoHS compliant

Trajexia motion control units

Item	Details			
Model	TJ2-MC64	TJ1-MC16	TJ1-MC04	
Number of axes	64	16	4 (+1 using TJ1-FL02 unit)	
Number of inverters and I/O modules	Up to 64 (Inverters in position, speed or torque mode)	8 maximum (Inverters in position, speed or torque mode)	8 maximum (Max. 4 Inverters in position mode)	
Motion bus	Number of EtherCAT master units ^{*1}	1 EtherCAT master is allowed per controller (see below TJ2-ECT64/ECT16/ECT04 for detailed info)	not supported	
	Number of ML2 master units	Up to 4 MECHATROLINK-II master units per controller (see below TJ1-ML16/ML04 for detailed info)		
Cycle time	Selectable 0.25 ms, 0.5 ms, 1 ms or 2 ms	Selectable 0.5 ms, 1 ms or 2 ms		
Programming language	BASIC-like motion language			
Multi-tasking	Up to 22 tasks running simultaneously	Up to 14 tasks running simultaneously		
Built-in digital I/O	16 inputs and 8 outputs, for general purpose			
Measurement units	User definable			
Available memory for user programs	8 MB	500 KB		
Data storage capacity	Up to 32 MB Flash data storage	Up to 2 MB Flash data storage		
Saving program data, motion controller	Flash-ROM	SRAM with battery backup and Flash-ROM		
Saving program data, personal computer	Via CX-Motion Pro/Trajexia Studio software			
Communication ports	1 Ethernet port and 2 serial ports			
Firmware update	Via CX-Motion Pro/Trajexia Studio software			
Ethernet port	Electrical characteristics	Conform to IEEE 802.3 (100BaseT)		
	Connector	RJ45 Ethernet connector		
	Transmission protocol	Modbus TCP slave		
		TELNET		
	FINS server and client			
	EtherNet/IP slave	not supported		
Serial port	Electrical characteristics	Conform 1 port to RS232C and 1 port to RS485/RS422A (selectable by switch)		
	Connector	SUB-D9 connector (Counterpart included in the package)		
	Synchronization	Start-stop synchronization (asynchronous)		
	Baud rate	1200 / 2400 / 4800 / 9600 / 19200 / 38400 bps		
	Transmission format	Databit length (7 or 8 bit)		
		Stop bit (1 or 2 bit)		
		Parity bit (Even/Odd/None)		
	Transmission mode	Point-to-multipoint (1:N)		
	Transmission protocol	RS-232C (1:1)	Host Link master protocol, Host Link slave protocol, ASCII general-purpose, Modbus RTU slave	
		RS-485 (1:N) RS-422A (1:N)	Host Link master protocol, Host Link slave protocol, ASCII general-purpose, Modbus RTU slave	
	Galvanic isolation	RS422A port		
	Communication buffers	254 bytes		
	Flow control	None		
Terminator	Yes, selectable by switch			
Cable length	15 m for RS232 and 500 meter for RS422/485			

*1. The EtherCAT master unit cannot be used in combination with a MECHATROLINK master unit when using TJ2-MC64 motion controller unit with firmware 2.0132.

Trajexia EtherCAT master units

Item	Specifications		
Model	TJ2-ECT64	TJ2-ECT16	TJ2-ECT04
Controlled devices with EtherCAT interface	Accurax G5 servo drive, MX2 inverter and SmartSlice IOs		
Electrical characteristics	Conform to Ethernet (IEEE 802.3), 100Base Tx		
Communications port	1 EtherCAT communication connector (to connect the EtherCAT twisted-pair cable)		
Transmission speed	100 Mbps		
Topology	Daisy chain, line or drop line		
Communications media	STP Category 5		
Communication cycle	0.5 ms, 1 ms or 2 ms		
Stations slave types ¹	Servo drives (axis) Frequency inverters (axis) I/O modules (devices)		
Number of axes per master / Cycle time ²	Max.64 axes/2 ms	Max. 16 axes/2 ms	Max. 4 axes/2 ms
	Max.32 axes/1 ms	Max. 16 axes/1 ms	Max. 4 axes/1 ms
	Max. 16 axes/0.5 ms	Max. 16 axes/0.5 ms	Max. 4 axes/0.5 ms
Transmission distance	Up to 100 meters between nodes		
Auxiliary I/Os	8 fast registration inputs		

*1. The TJ2-MC64 CPU supports a total of 1024 digital I/O points and 36 analogue I/O points.

*2. The number of axes per master/ cycle time is currently (TJ2-MC64 motion controller with firmware 2.01.32) limited to:

- Max. 32 axes @ 2ms
- Max. 16 axes @ 1 ms
- Max. 8 axes @ 0.5 ms

Trajexia MECHATROLINK-II master units

Item	Specifications	
Model	TJ1-ML16	TJ1-ML04
Controlled devices with MECHATROLINK-II interface	Accurax G5, G-Series, MX2 inverter and SmartSlice IOs	
Electrical characteristics	Conforms to MECHATROLINK standard	
Communication ports	1 MECHATROLINK-II master	
Transmission speed	10 Mbps	
Communication cycle	0.5 ms, 1 ms or 2 ms	
Stations slave types	Axes or servo drives Frequency inverters I/O modules	
Number of stations per master / Cycle time	Max.16 Stations/2 ms	Max. 4 Stations/2 ms
	Max. 8 Stations/1 ms	Max. 4 Stations/1 ms
Transmission distance	Max. 50 meters without using repeater	

Trajexia PROFIBUS slave unit

Items	Specifications
Model	TJ1-PRT
PROFIBUS standard	Conforms to PROFIBUS-DP standard EN50170 (DP-V0)
Communication ports	1 PROFIBUS-DP slave
Transmission speed	9.6, 19.2, 45.45, 93.75, 187.5, 500, 1500, 3000, 6000 and 12000 kbps
Node numbers	0 to 99
I/O size	0 to 122 words (16 bit), configurable, for both directions
Galvanic isolation	Yes

Trajexia DeviceNet slave unit

Items	Specifications
Model	TJ1-DRT
DeviceNet standard	Conforms to DeviceNet standard of CIP edition 1
Communication ports	1 DeviceNet slave
Transmission speed	125, 250 and 500 Kbps, auto-detect
Node numbers	0 to 63
I/O size	0 to 32 words (16 bit), configurable, for both directions
Galvanic isolation	Yes

Trajexia CANopen unit

Items	Specifications
Model	TJ1-CORT
Electrical Characteristics	Conforms to CAN 2.0 B
Communication ports	1 CANopen
Transmission speed	20, 50, 125 and 500 Kbps
Implemented CiA Standards	DS301, DS302
PDO Support	8 TPDO and 8 RPDO
PDO Mapping	Each PDO can be mapped into TJ1-MC16/04 VR, table, analogue and digital IO. BASIC commands assign mapping and start address ^{*1}
CANopen slave configuration	Any SDO message can be sent using BASIC during start-up and operation
CANopen network states	CANopen network can be set to pre-operational and operational using BASIC
CANopen slave emergencies	Available using BASIC command
Galvanic isolation	Yes

*1. The TJ1-MC16/04 CPUs support a total of 256 digital I/O points and 36 analogue I/O points. The TJ2-MC64 CPU supports a total of 1024 digital I/O points and 36 analogue I/O points.

Trajexia flexible axis unit

Items		Specifications
Model		TJ1-FL02
Number of axes		2. Every axis has 1 analog output, 1 encoder in/out -software configurable - and several digital I/O
Control methods (independent per axis)		±10 V analogue output + encoder input (closed loop) Line driver AB output Stepper pulse output in closed loop or pulse train output in open loop
Encoder	Encoder protocols	Abs SSI 200 kHz, Abs EnDat 1 MHz, Abs Tamagawa and Incremental Line driver AB
	Encoder Input maximum frequency	6 MHz
	Encoder/pulse output max. frequency	2 MHz
Auxiliary I/Os		2 fast registration inputs, 2 definable inputs, 2 enable output, 4 position switch outputs or axes reset
Galvanic isolation		Yes

SmartSlice EtherCAT interface unit

Item	Specifications
Model	GRT1-ECT
Electrical characteristics	Conform to Ethernet (IEEE 802.3), 100Base-TX
Communication cycle	0.25 ms min.
Power supply	24 VDC
Number of connectable Slices	Up to 64 slices with a maximum amount of 128 bytes ^{*1}
IO mapping	Automatic analogue and digital IO mapping into TJ2-MC64 CPU
Slice unit configuration	Not supported
Supported slice units	See ordering information section

*1. The TJ2-MC64 CPU supports a total of 1024 digital I/O points and 36 analogue I/O points.

SmartSlice MECHATROLINK-II interface unit

Item	Specifications
Model	GRT1-ML2
Electrical characteristics	Conform to MECHATROLINK standard
Communication cycle	0.5, 1 or 2 ms
Power supply	24 VDC
Number of connectable Slices	Up to 64 slices with a maximum amount of 128 bytes ^{*1}
IO mapping	Automatic analogue and digital IO mapping into TJ1-MC16/04 and TJ2-MC64 CPUs
Slice unit configuration	Not supported
Supported slice units	See ordering information section

*1. The TJ1-MC16/04 CPUs support a total of 256 digital I/O points and 36 analogue I/O points.
The TJ2-MC64 CPU supports a total of 1024 digital I/O points and 36 analogue I/O points.

Nomenclature

Trajexia motion controller unit - TJ2-MC64, TJ1MC-16/04

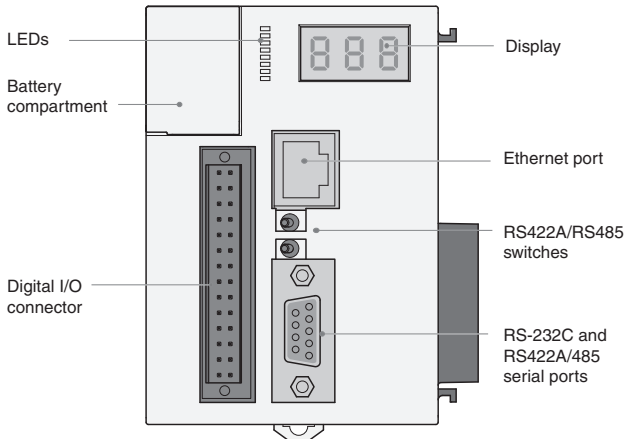

Trajexia EtherCAT master unit - TJ2-ECT04/16/64

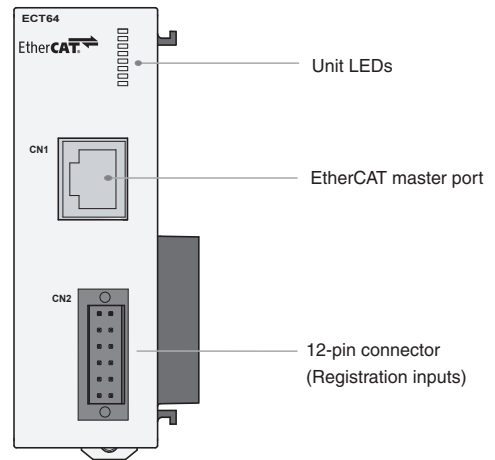

Trajexia DeviceNet slave unit - TJ1-DRT

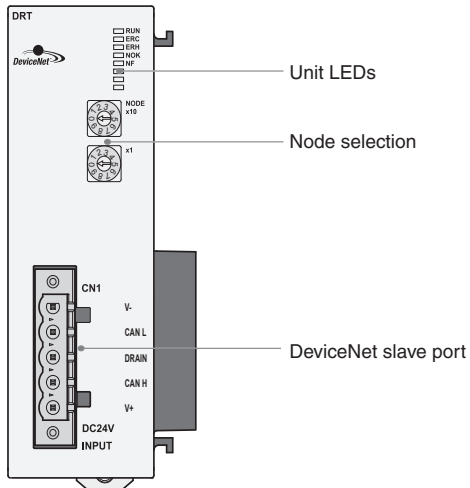

Trajexia MECHATROLINK-II master unit - TJ1-ML16/04

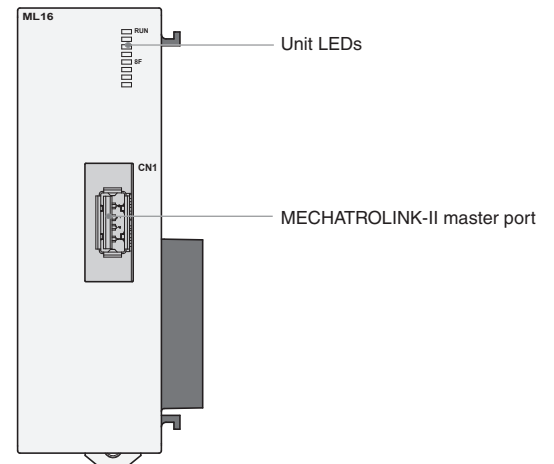

Trajexia PROFIBUS-DP unit - TJ1-PRT

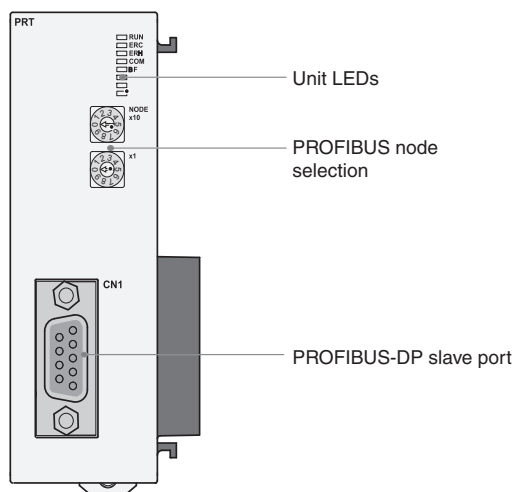

Trajexia CANopen unit - TJ1-CORT

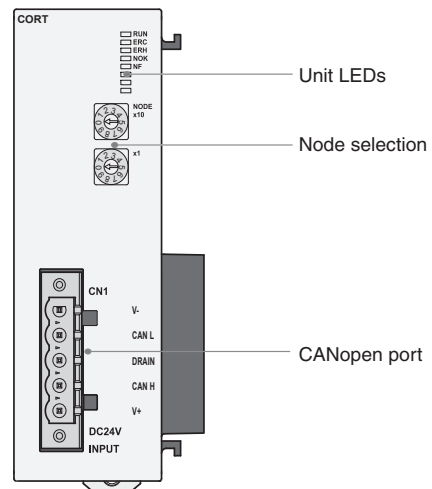

Trajexia Flex axis unit - TJ1-FL02

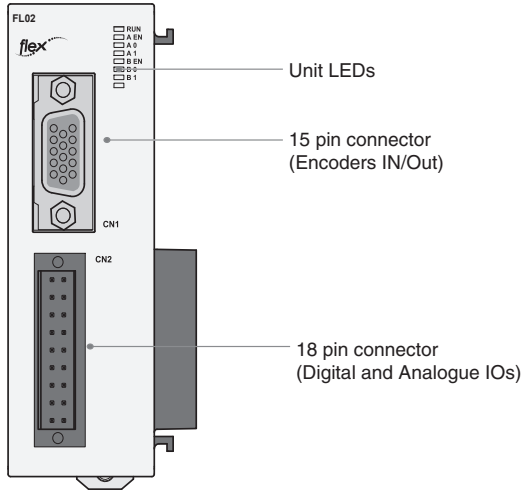

SmartSlice EtherCAT interface unit - GRT1-ECT

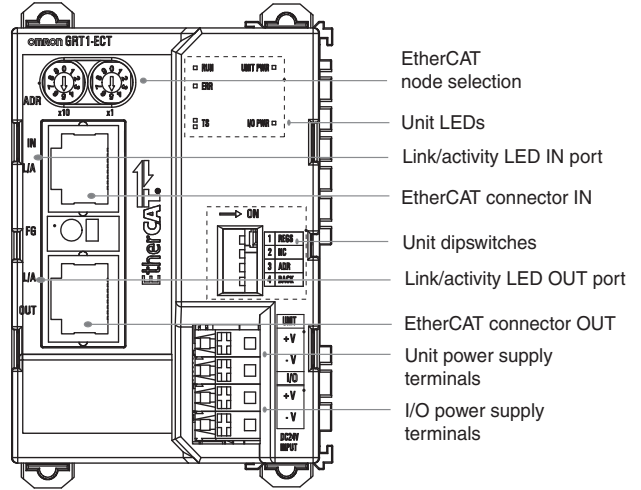

SmartSlice MECHATROLINK-II interf. unit - GRT1-ML2

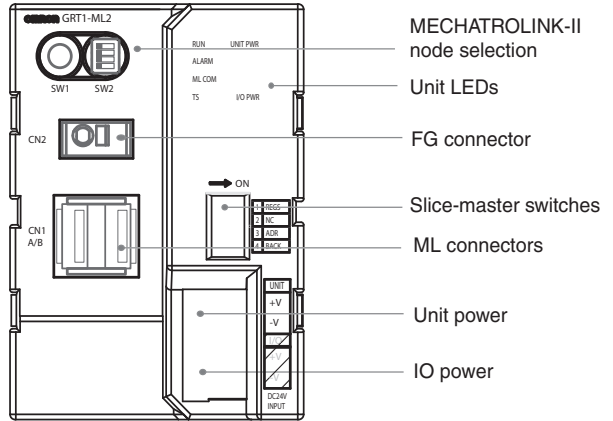

Dimensions

Trajexia motion controller - TJ2-MC64, TJ1-MC16/04

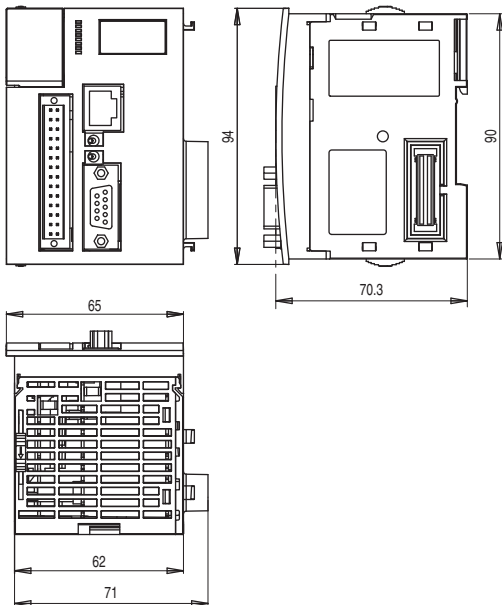

Trajexia units - TJ1-ML16/04, -PRT, -DRT, -CORT, -FL02, TJ2-ECT64/16/04

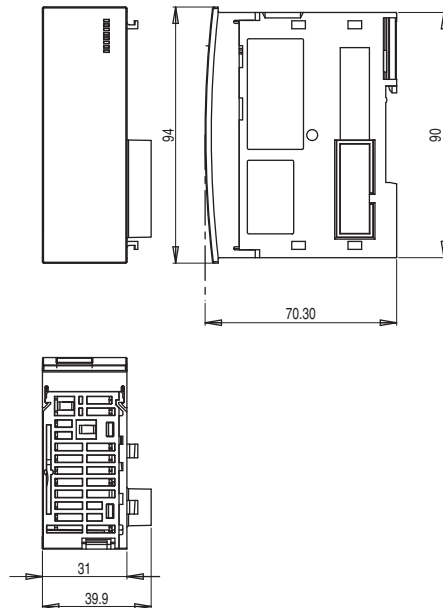

Trajexia system - CJ1W-PA202 + TJ1-MC16 + one module + TJ1-TER

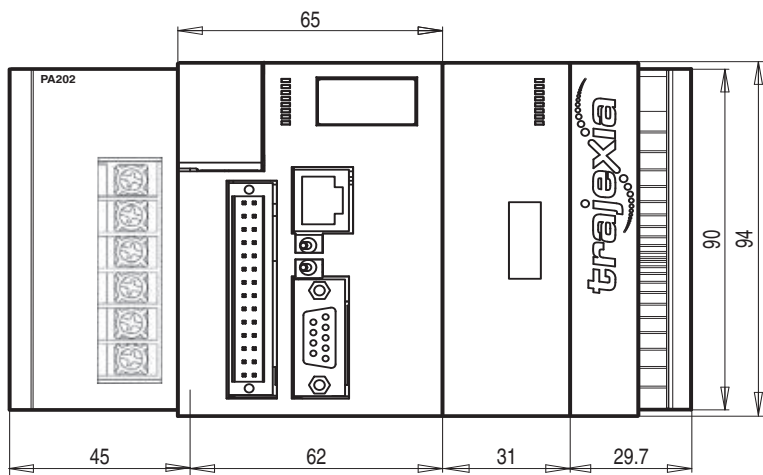

SmartSlice interface unit - GRT1-ML2

SmartSlice interface unit - GRT1-ECT

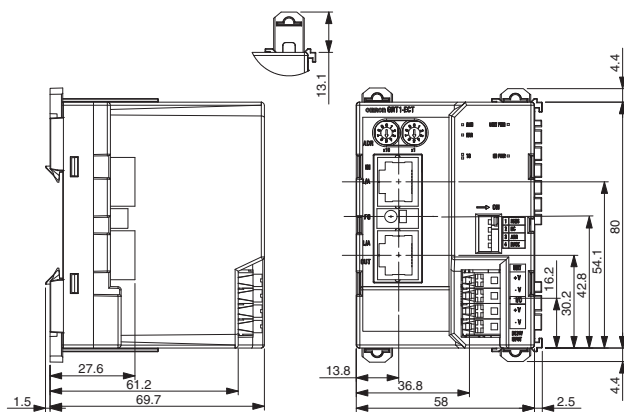
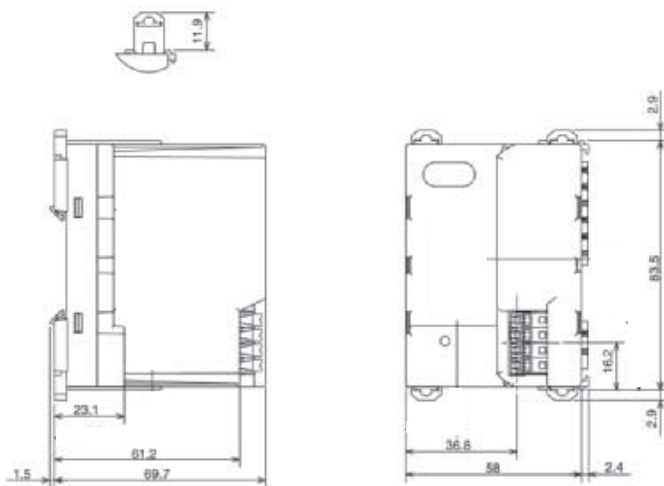

SmartSlice end unit - GRT1-END

SmartSlice I/O units - GRT1-

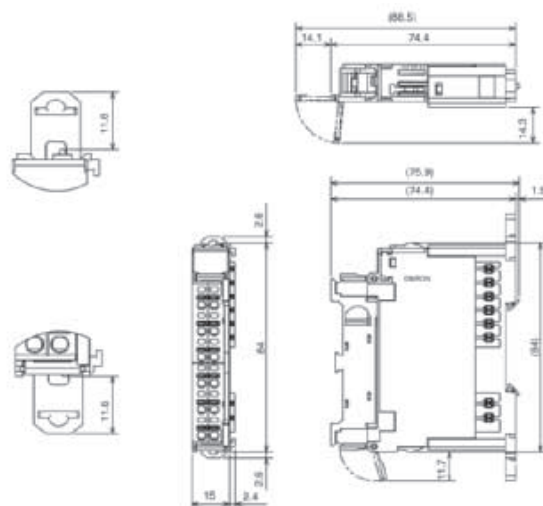
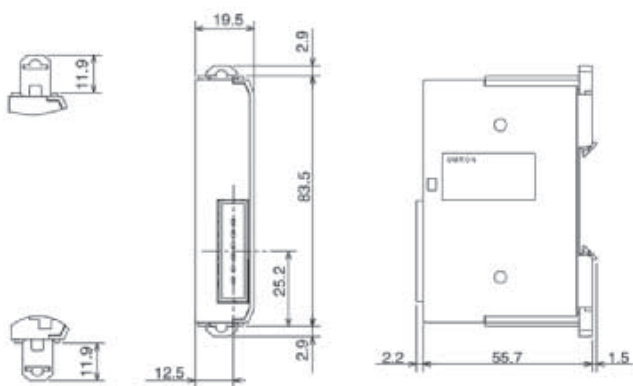

Ordering information

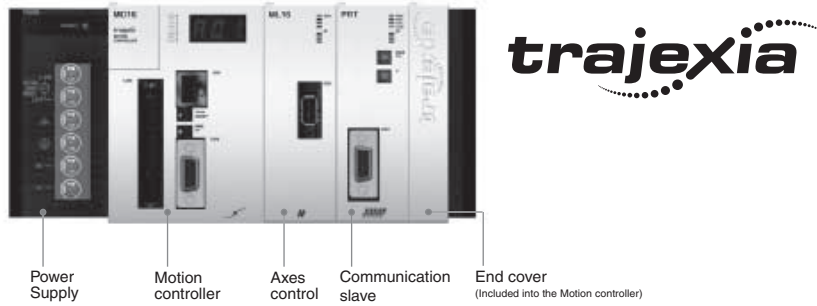

Trajexia motion controller

Name	Model
Trajexia motion controller Unit, up to 64 axes. (Trajexia end cover unit TJ1-TER is included)	TJ2-MC64
Trajexia motion controller unit, up to 16 axes. (Trajexia end cover unit TJ1-TER is included)	TJ1-MC16
Trajexia motion controller unit, up to 4 axes. (Trajexia end cover unit TJ1-TER is included)	TJ1-MC04
Power supply for Trajexia system, 100-240 VAC	CJ1W-PA202
Power supply for Trajexia system, 24 VDC	CJ1W-PD022

Trajexia - axes control modules

Name	Model
Trajexia EtherCAT master unit (up to 64 servo drives) ^{*1}	TJ2-ECT64
Trajexia EtherCAT master unit (up to 16 servo drives)	TJ2-ECT16
Trajexia EtherCAT master unit (up to 4 servo drives)	TJ2-ECT04
Trajexia MECHATROLINK-II master unit (up to 16 stations)	TJ1-ML16
Trajexia MECHATROLINK-II master unit (up to 4 stations)	TJ1-ML04
Trajexia flexible axis unit (for 2 stations)	TJ1-FL02

*1. The number of servo drives is currently limited to 32 when using TJ2-MC64 motion controller with firmware 2.0132.

Note: The TJ1-ML04 and TJ1-ML16 supported by the TJ2-MC64 motion controller are V2 (Version 2) and lot number equal or above Lot. No.091019 (YYMMDD).

Trajexia - communication modules

Name	Model
Trajexia DevicNet slave unit	TJ1-DRT
Trajexia PROFIBUS-DP slave unit	TJ1-PRT
Trajexia CANopen unit	TJ1-CORT

EtherCAT - related devices

Servo system & frequency inverters

Name	Model	
Accurax G5 servo drive EtherCAT built-in	R88D-KN□□□-ECT	
MX2 inverter with EtherCAT option board	Frequency inverter	3G3MX2-A□
	EtherCAT option board	3G3AX-MX2-ECT

Note: Refer to servo systems and frequency inverter sections for detailed specs and ordering information

SmartSlice IOs system

Function	Specification	Model
SmartSlice Interface unit	SmartSlice EtherCAT interface unit	GRT1-ECT
End plate, one unit required per bus interface		GRT1-END
4 NPN inputs	24 VDC, 6 mA, 3-wire connection	GRT1-ID4
4 PNP inputs	24 VDC, 6 mA, 3-wire connection	GRT1-ID4-1
8 NPN inputs	24 VDC, 4 mA, 1-wire connection + 4xG	GRT1-ID8
8 PNP inputs	24 VDC, 4 mA, 1-wire connection + 4xV	GRT1-ID8-1
4 AC inputs	110 VAC, 2-wire connection	GRT1-IA4-1
4 AC inputs	230 VAC, 2-wire connection	GRT1-IA4-2
4 NPN outputs	24 VDC, 500 mA, 2-wire connection	GRT1-OD4
4 PNP outputs	24 VDC, 500 mA, 2-wire connection	GRT1-OD4-1
4 PNP outputs with short-circuit protection	24 VDC, 500 mA, 3-wire connection	GRT1-OD4G-1
4 PNP outputs with short-circuit protection	24 VDC, 2 A, 2-wire connection	GRT1-OD4G-3
8 NPN outputs	24 VDC, 500 mA, 1-wire connection + 4xV	GRT1-OD8
8 PNP outputs	24 VDC, 500 mA, 1-wire connection + 4xG	GRT1-OD8-1
8 PNP outputs with short-circuit protection	24 VDC, 500 mA, 1-wire connection + 4xG	GRT1-OD8G-1
2 relay outputs	240 VAC, 2 A, normally-open contacts	GRT1-ROS2
2 analogue inputs, current/voltage	±10 V, 0-10 V, 0-5 V, 1-5 V, 0-20 mA, 4-20 mA	GRT1-AD2
2 analogue outputs, voltage	± 10 V, 0-10 V, 0-5 V, 1-5 V	GRT1-DA2V
2 analogue outputs, current	0-20 mA, 4-20 mA	GRT1-DA2C
2 Pt100 inputs	Pt100, 2-wire or 3-wire connection	GRT1-TS2P
2 Pt1000 inputs	Pt1000, 2-wire or 3-wire connection	GRT1-TS2K
2 Thermocouple inputs	Types B, E, J, K, N, R, S, T, U, W, PL2, with cold junction compensation	GRT1-TS2T

Note: Refer to Automation systems catalogue for detailed specs and accessories information

GX-Series I/O Blocks

Name	Specification	Model
16 NPN inputs	24 VDC, 6 mA, 1-wire connection, expandable	GX-ID1611
16 PNP inputs	24 VDC, 6 mA, 1-wire connection, expandable	GX-ID1621
16 NPN outputs	24 VDC, 500 mA, 1-wire connection, expandable	GX-OD1611
16 PNP outputs	24 VDC, 500 mA, 1-wire connection, expandable	GX-OD1621
8 inputs and 8 outputs, NPN	24 VDC, 6 mA input, 500 mA output, 1-wire connection	GX-MD1611
8 inputs and 8 outputs, PNP	24 VDC, 6 mA input, 500 mA output, 1-wire connection	GX-MD1621
16 NPN inputs	24 VDC, 6 mA, 3-wire connection	GX-ID1612
16 PNP inputs	24 VDC, 6 mA, 3-wire connection	GX-ID1622
16 NPN outputs	24 VDC, 500 mA, 3-wire connection	GX-OD1612
16 PNP outputs	24 VDC, 500 mA, 3-wire connection	GX-OD1622
8 inputs and 8 outputs, NPN	24 VDC, 6 mA input, 500 mA output, 3-wire connection	GX-MD1612
8 inputs and 8 outputs, PNP	24 VDC, 6 mA input, 500 mA output, 3-wire connection	GX-MD1622
16 relay outputs	250 VAC, 2 A, 1-wire connection, expandable	GX-OC1601
4 analogue inputs, current/voltage	±10 V, 0-10 V, 0-5 V, 1-5 V, 4-20 mA	GX-AD0471
2 analogue outputs, current/voltage	±10 V, 0-10 V, 0-5 V, 1-5 V, 4-20 mA	GX-DA0271
2 encoder open collector inputs	500 kHz Open collector input	GX-EC0211
2 encoder line-driver inputs	4 MHz Line driver input	GX-EC0241

Note: The GX-Series I/O blocks are only supported by the T2-MC64 motion controller and with official firmware release above 2.0132.

Vision system

Name	Specification	Model
Vision system with EtherCAT interface	NPN	FZM1-350-ECT
	PNP	FZM1-355-ECT
Smart camera with EtherCAT interface	NPN/ Color camera	FQ-MS120-ECT
	NPN/ Monochrome camera	FQ-MS120-M-ECT
	PNP/ Color camera	FQ-MS125-ECT
	PNP/ Monochrome camera	FQ-MS125-M-ECT

Note: The vision systems are only supported by the T2-MC64 motion controller and with official firmware release above 2.0132.

MECHATROLINK-II - related devices

Servo system & frequency inverters

Name	Specification	Model
Accurax G5 servo drive ML-II built-in		R88D-KN□□□-ML2
G-Series servo drive ML-II built-in		R88D-GN□□□H-ML2
MX2 inverter with MECHATROLINK-II option board	Frequency inverter	3G3MX2-A□
	ML2 option board	3G3AX-MX2-MRT

Note: Refer to servo systems and frequency inverter sections for detailed specs and ordering information

SmartSlice IOs system

Function	Specification	Model
SmartSlice Interface unit	SmartSlice MECHATROLINK-II interface unit	GRT1-ML2 ^{*1}
End plate, one unit required per bus interface		GRT1-END
4 NPN inputs	24 VDC, 6 mA, 3-wire connection	GRT1-ID4
4 PNP inputs	24 VDC, 6 mA, 3-wire connection	GRT1-ID4-1
8 NPN inputs	24 VDC, 4 mA, 1-wire connection + 4xG	GRT1-ID8
8 PNP inputs	24 VDC, 4 mA, 1-wire connection + 4xV	GRT1-ID8-1
4 AC inputs	110 VAC, 2-wire connection	GRT1-IA4-1
4 AC inputs	230 VAC, 2-wire connection	GRT1-IA4-2
4 NPN outputs	24 VDC, 500 mA, 2-wire connection	GRT1-OD4
4 PNP outputs	24 VDC, 500 mA, 2-wire connection	GRT1-OD4-1
4 PNP outputs with short-circuit protection	24 VDC, 500 mA, 3-wire connection	GRT1-OD4G-1
4 PNP outputs with short-circuit protection	24 VDC, 2 A, 2-wire connection	GRT1-OD4G-3
8 NPN outputs	24 VDC, 500 mA, 1-wire connection + 4xV	GRT1-OD8
8 PNP outputs	24 VDC, 500 mA, 1-wire connection + 4xG	GRT1-OD8-1
8 PNP outputs with short-circuit protection	24 VDC, 500 mA, 1-wire connection + 4xG	GRT1-OD8G-1
2 relay outputs	240 VAC, 2 A, normally-open contacts	GRT1-ROS2
2 analogue inputs, current/voltage	±10 V, 0-10 V, 0-5 V, 1-5 V, 0-20 mA, 4-20 mA	GRT1-AD2
2 analogue outputs, voltage	±10 V, 0-10 V, 0-5 V, 1-5 V	GRT1-DA2V
2 analogue outputs, current	0-20 mA, 4-20 mA	GRT1-DA2C
2 Pt100 inputs	Pt100, 2-wire or 3-wire connection	GRT1-TS2P
2 Pt1000 inputs	Pt1000, 2-wire or 3-wire connection	GRT1-TS2K
2 Thermocouple inputs	Types B, E, J, K, N, R, S, T, U, W, PL2, with cold junction compensation	GRT1-TS2T

*1. The GRT1-ML2 supports the GRT1-IA4-1, GRT1-IA4-2, GRT1-OD4G-3, GRT1-TS2P, GRT1-TS2K and GRT1-TS2T slice units only in combination with TJ2-MC64 motion controller. They are not supported in combination with TJ1-MC16/04.

Refer to Automation systems catalogue for detailed specs and accessories information

MECHATROLINK-II cables

Name	Remarks	Model
MECHATROLINK-II cables	0.5 meter	JEPMC-W6003-A5
	1 meter	JEPMC-W6003-01
	3 meters	JEPMC-W6003-03
	5 meters	JEPMC-W6003-05
	10 meters	JEPMC-W6003-10
	20 meters	JEPMC-W6003-20
	30 meters	JEPMC-W6003-30
MECHATROLINK-II terminator	Terminating resistor	JEPMC-W6022
MECHATROLINK-II repeater	Network repeater	JEPMC-REP2000

Computer software

Specifications	Model
CX-Motion Pro V1.3.3 or higher	CX-One
Trajexia Studio ^{*1} V1.3.3 or higher	TJ1-Studio

*1. When the Trajexia Studio software is included in CX-One, then it is called CX-Motion Pro.

ALL DIMENSIONS SHOWN ARE IN MILLIMETERS.

To convert millimeters into inches, multiply by 0.03937. To convert grams into ounces, multiply by 0.03527.

CJ1W-NC□8□ - NC EtherCAT

Position control unit

Multi-axis point-to-point positioning controller over EtherCAT

- Position control units with 2, 4, 8 or 16 axes.
- NC_82 models support up to 64 additional nodes: inverters, vision systems and distributed I/Os.
- Linear and circular interpolation.
- Linear and infinite axes management.
- Programming languages: ladder and function blocks. Certified PLCopen motion control function blocks.
- The unit can perform various operation sequences in the memory operation data.
- CX-Programmer software for unit setup, EtherCAT network configuration and PLC programming.



System configuration

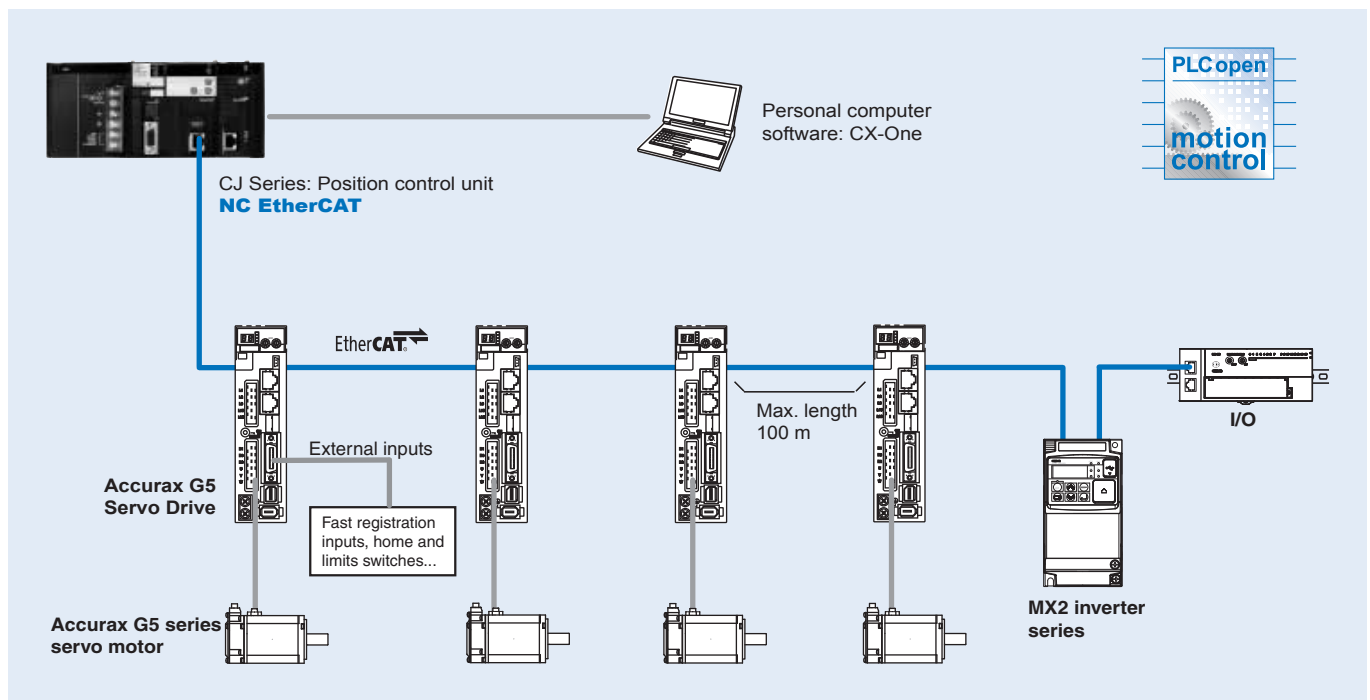

Specifications

Position control unit

Model	CJ1W-NC281	CJ1W-NC481	CJ1W-NC881	CJ1W-NCF81	CJ1W-NC482	CJ1W-NC882	CJ1W-NCF82
Classification	CJ-series CPU bus unit						
Applicable PLCs	CJ-series V. 3.0 or later in order to use function blocks						
Possible unit number settings	0 to F						
Number of units per PLC	10 units per rack, 16 units in total (with expansion racks)						
Control method	EtherCAT commands (CoE)						
Controlled servo drives	Accurax G5 servo drives with EtherCAT built-in						
Controlled axes	2	4	8	16	4 + 64 nodes for remote I/O ^{*1}	8 + 64 nodes for remote I/O ^{*1}	16 + 64 nodes for remote I/O ^{*1}
Virtual axes	-	-	-	-	When a physical axis is disabled, it will operate as virtual axis.		
Node address setting range	1 to 2	1 to 4	1 to 8	1 to 16	1 to 4 and 17 to 80 ^{*2}	1 to 8 and 17 to 80 ^{*2}	1 to 16 and 17 to 80 ^{*2}
I/O allocations	Common operating memory area	Words allocated in CPU bus unit area: 25 words					
	Axis operating memory area	Allocated in one of the following areas (user-specified): CIO, WR, DM, or EM area. Number of words allocated: 43 words for each node (2+12 output words, 13+16 input words)					
	Memory operation memory areas	Allocated in one of the following areas (user-specified): CIO, WR, DM, or EM area. Number of words allocated: 7 words for each task (3 output words, 4 input words)					
	I/O memory areas	-	-	-	-	Allocated in one of the following areas (user-specified): CIO, WR, DM, or EM area. Number of words: 1,300 words maximum (640 output words, 640 input words, 20 communication status words).	
Control command range	Position command range	-2,147,483,648 to 2,147,483,647 (command units)					
	Speed command range for position control	1 to 2,147,483,647 (command units/s)					
Control functions	Positioning functions	Memory operation or direct operation					
	Linear interpolation	Up to 2 axes	Up to 4 axes				
	Circular interpolation	Up to 2 axes					
	Origin determination	<ul style="list-style-type: none"> • Origin search: establishes the origin using the specified search method. • Present position preset: changes the present position to a specified position to establish the origin. • Origin return: returns the axis from any position to the established origin. • Absolute encoder origin: establishes the origin using a servo motor that has an absolute encoder. 					
	Jogging	Outputs a fixed speed in the CW or CCW direction.					
	Interrupt feeding	Performs positioning by moving the axis a fixed amount when an external interrupt input is received while the axis is moving.					
	Stop functions	Deceleration stop and emergency stop.					
Auxiliary functions	Acceleration/deceleration curves	Sets either a trapezoidal (linear) curve or an S-curve (moving average).					
	Torque limit	Restricts the torque upper limit during position control.					
	Overrides	Multiplies the axis command speed by a specified ratio during operation. Axis setting: 0.01% to 500%					
	Servo parameter transfer	Reads and writes the servo drive parameters from the ladder program in the CPU unit.					
	Monitoring function	Monitors the control status of the servo drive's command coordinate positions, feedback position, current speed, torque, etc.					
	Software limits	Sets forward and reverse software limits for axis operation. Can be set for each axis.					
	Backlash compensation	Compensates for the amount of play in the mechanical system according to a set value.					
	Deviation counter reset	The position deviation in the servo drive's deviation counter can be reset to 0 (unit version 1.3 or later).					
	Teaching	This function can be used to record the present position into specified position data after moving to the desired position, e.g., by using jogging.					
EtherCAT master port	Drive Profile ^{*3}	CSP mode (CiA402 DriveProfile),			CSP, CSV, CST modes (CiA402 DriveProfile) ^{*4}		
		Touch probe function (Latch function and Torque limit function)					
	Communications cycle	250 us, 500 us, 1ms or 2 ms depending on the number of slaves connected and slaves specifications.					
	Communications standard	IEC 61158 Type 12					
	Physical layer	100Base-TX (IEEE802.3)					
	Connector	RJ45 connector x 1					
	Communications media	Category 5 or higher (recommended: cable with double, aluminum tape and braided shielding)					
	Communications distance	Distance between nodes: 100 m max.					
Programming methods	Standard ladder	Directly over NC unit memory area					
	Function blocks	Using standard PLCopen motion control function blocks					
	Sequence functions	<p>The unit can perform various operation sequences in the memory operation data without affecting the ladder programming in the CPU. For continuous positioning and speed changes.</p> <p>4 tasks x 500 steps</p>					
Applicable standards	Conforms to cULus and EC Directives.						
Internal current consumption	460 mA or less at 5 VDC						
Weight	110 g						

Notes: *1 Support for 64 I/O, inverter and vision system device nodes.
*2 Node address 17 to 80 are reserved for remote I/O slaves.
*3 This profile is used when the unit is connected to the Accurax G5 servo drive.
*4 The CSV and CST modes are supported only with NC_82 unit version 1.3 or higher combined with CJ2H-CPU ver. 1.4 or higher.



Nomenclature

CJ1W-NC□8□ - position control unit

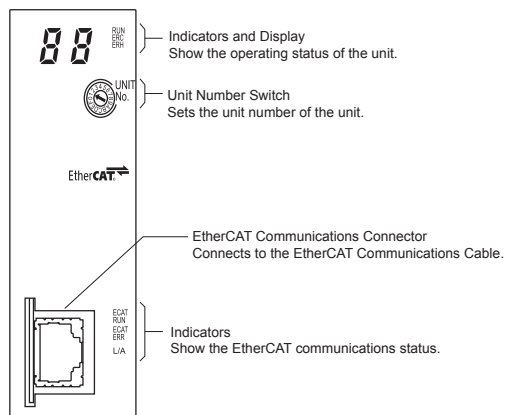
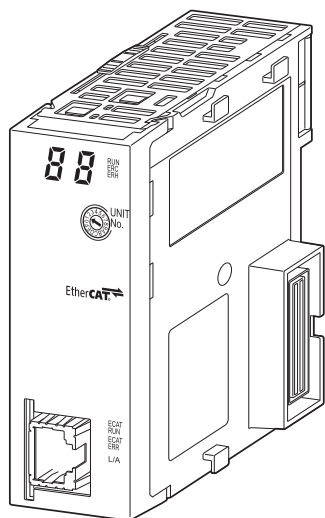

Dimensions

CJ1W-NC□8□ - position control unit

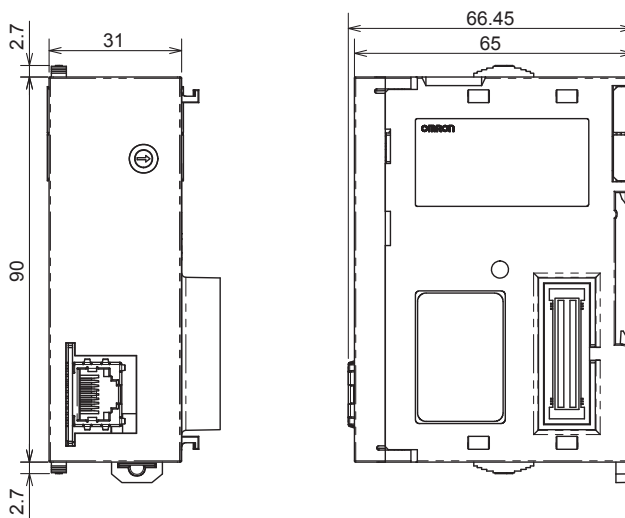

Ordering information

Position controller unit

Name	Model
Position controller unit - EtherCAT - 16 axes + 64 nodes for remote I/O	CJ1W-NCF82
Position controller unit - EtherCAT - 8 axes + 64 nodes for remote I/O	CJ1W-NC882
Position controller unit - EtherCAT - 4 axes + 64 nodes for remote I/O	CJ1W-NC482
Position controller unit - EtherCAT - 16 axes	CJ1W-NCF81
Position controller unit - EtherCAT - 8 axes	CJ1W-NC881
Position controller unit - EtherCAT - 4 axes	CJ1W-NC481
Position controller unit - EtherCAT - 2 axes	CJ1W-NC281

EtherCAT related devices

Servo system & frequency inverter

Name	Model
Accurax G5 servo drive EtherCAT built-in	R88D-KN□□□-ECT
MX2 inverter with EtherCAT option board	3G3MX2-A□
Frequency inverter	3G3AX-MX2-ECT
EtherCAT option board	

Note: Refer to servo system and frequency inverter sections for detailed specs and ordering information.

GX-Series I/O Blocks

Name		Model
16 NPN inputs	24 VDC, 6 mA, 1-wire connection, expandable	GX-ID1611
16 PNP inputs	24 VDC, 6 mA, 1-wire connection, expandable	GX-ID1621
16 NPN outputs	24 VDC, 500 mA, 1-wire connection, expandable	GX-OD1611
16 PNP outputs	24 VDC, 500 mA, 1-wire connection, expandable	GX-OD1621
8 inputs and 8 outputs, NPN	24 VDC, 6 mA input, 500 mA output, 1-wire connection	GX-MD1611
8 inputs and 8 outputs, PNP	24 VDC, 6 mA input, 500 mA output, 1-wire connection	GX-MD1621
16 NPN inputs	24 VDC, 6 mA, 3-wire connection	GX-ID1612
16 PNP inputs	24 VDC, 6 mA, 3-wire connection	GX-ID1622
16 NPN outputs	24 VDC, 500 mA, 3-wire connection	GX-OD1612
16 PNP outputs	24 VDC, 500 mA, 3-wire connection	GX-OD1622
8 inputs and 8 outputs, NPN	24 VDC, 6 mA input, 500 mA output, 3-wire connection	GX-MD1612
8 inputs and 8 outputs, PNP	24 VDC, 6 mA input, 500 mA output, 3-wire connection	GX-MD1622
16 relay outputs	250 VAC, 2 A, 1-wire connection, expandable	GX-OC1601
4 analogue inputs, current/voltage	±10 V, 0-10 V, 0-5 V, 1-5 V, 4-20 mA	GX-AD0471
2 analogue outputs, current/voltage	±10 V, 0-10 V, 0-5 V, 1-5 V, 4-20 mA	GX-DA0271
2 encoder open collector inputs	500 kHz Open collector input	GX-EC0211
2 encoder line-driver inputs	4 MHz Line driver input	GX-EC0241

Note: Refer to Automation systems catalogue for detailed specs and ordering information.

Vision system

Name	Specification	Model
Vision system with EtherCAT interface	NPN	FZM1-350-ECT
	PNP	FZM1-355-ECT

Note: Refer to vision system documentation for detailed specs and ordering information.

Computer software

Specifications	Model
CX-One version 4 or higher	CX-One
CX-Programmer version 9.12 or higher	CX-Programmer

ALL DIMENSIONS SHOWN ARE IN MILLIMETERS.
To convert millimeters into inches, multiply by 0.03937. To convert grams into ounces, multiply by 0.03527.

Trajexia-PLC CJ1W-MC472/ MCH72 - MECHATROLINK-II

Trajexia motion control unit

PLC-based motion controller unit over MECHATROLINK-II motion bus

- Models with 4 or 30 MECHATROLINK-II axes
- Selectable cycle time from 0.5 ms to 4 ms
- Control of servos and inverters over a single motion network
- Supports position, speed and torque control
- Advanced motion control such as CAM control, registration control, interpolation and axes synchronization via simple motion commands
- Serial port for master encoder axis
- Embedded digital I/Os
- I/O data exchange with the PLC CPU



System configuration

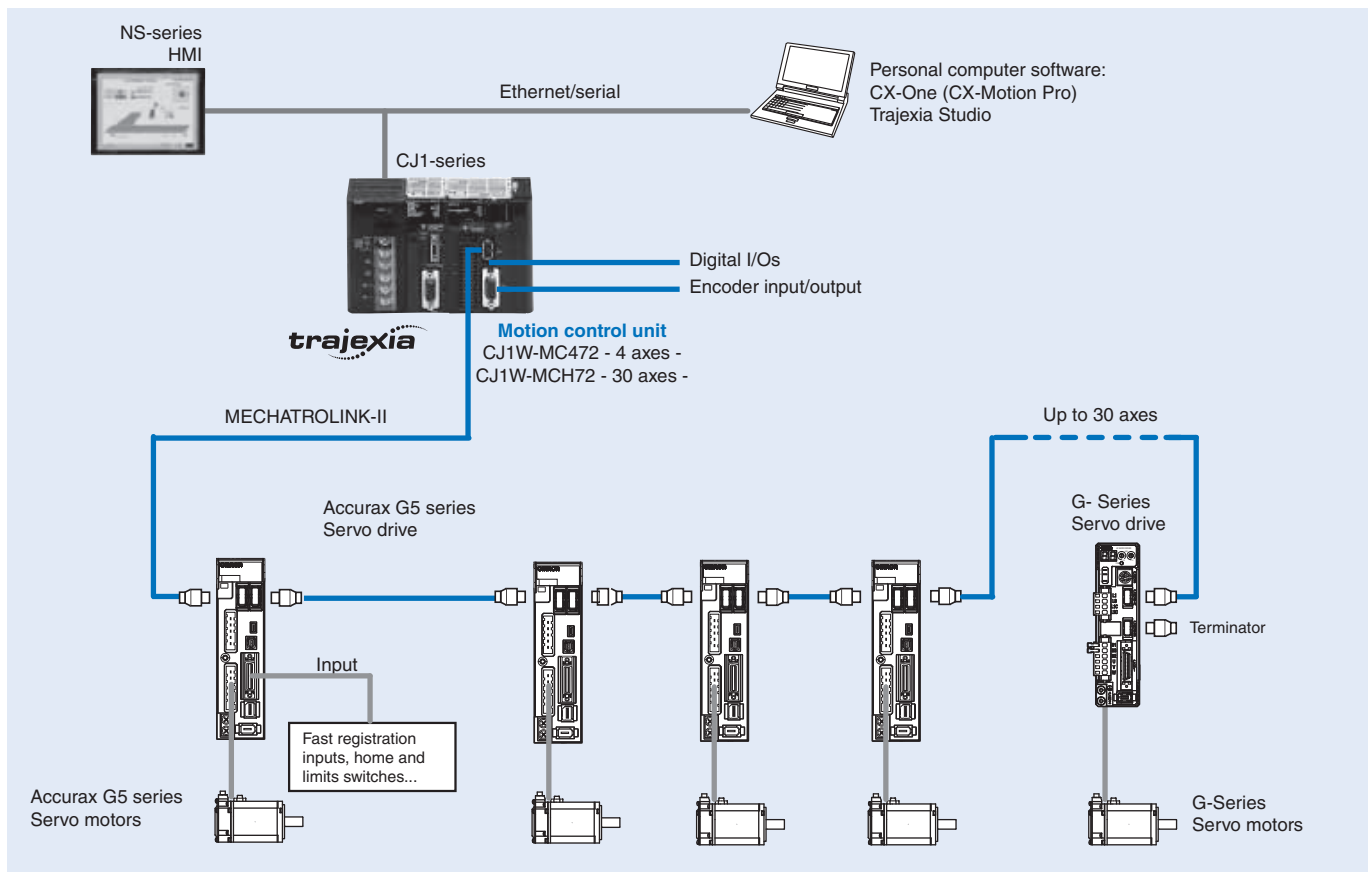

Specifications

General specifications

Item	Details
Model	CJ1W-MC□72
Ambient operating temperature	0 to 55°C
Storage temperature	-20° to 70°C
Ambient operating humidity	10% to 90% RH
Storage humidity	90% max. (without condensation)
Atmosphere	No corrosive gases
Vibration resistance	10 to 57 Hz (0.075 mm amplitude) 57 to 100 Hz, Acceleration: 9,8 m/s ² , in X Y and Z directions for 80 minutes
Shock resistance	143 m/s ² , 3 times each X, Y, Z directions
Insulation resistance	20 MOhm
Dielectric strength	500 V
Protective structure	IP20
International standards	CE: IEC61131-2, IEC61000-6-2, IEC61000-6-4 cULus: UL508 (Industrial Control Equipment) Lloyds; RoHS compliant
Weight	180 g

Trajexia Motion Control Unit

Item	Details		
Model	CJ1W-MCH72 CJ1W-MC472		
Classification	CJ-series CPU bus unit		
Applicable PLCs	CJ-series		
Axes	Total number of axes	32	
	MECHATROLINK-II axes	30 maximum* ¹ 4 maximum* ²	
	Master encoder axis	1 maximum	
	Virtual axis	32 maximum	
MECHATROLINK nodes	Total number of nodes	30 12	
	Servo Drive	30 maximum 4 maximum	
	Inverter	8 maximum 8 maximum	
Cycle time	Selectable 0.5 ms, 1 ms, 2 ms or 4 ms		
Programming language	BASIC-like motion language		
Multi-tasking	Up to 14 tasks running simultaneously		
Built-in digital I/O	16 inputs, 2 with registration functionality. 8 outputs, 1 with hardware position switch functionality		
Measurement units	User definable		
Available memory for user programs	500 KB		
Data storage capacity	Up to 2 MB flash data storage		
Saving program data, motion controller unit	SRAM with battery backup and Flash-ROM		
Saving program data, personal computer	Via CX-Motion Pro/Trajexia Studio software		
Firmware update			
Encoder interface	Control method	Line driver AB output, Stepper pulse input/output	
	Encoder protocols	Abs SSI 200 kHz, Abs EnDat 1 MHz and Incremental Line driver AB	
	Encoder Input max frequency	6 MHz	
	Encoder/Pulse output max frequency	2 MHz	
MECHATROLINK-II master port	Controlled devices	Accurax G5 and G-Series servo drives, MX2 inverters	
	Electrical characteristics	Conforms to MECHATROLINK standard	
	Transmission speed	10 Mbps	
	Stations Slave types	Servo drives and frequency inverters	
	Number of MECHATROLINK nodes/ Cycle time	Max. 30 nodes/ 4 ms Max. 16 nodes/ 2 ms Max. 8 nodes/ 1ms	Max. 12 nodes/ 4 ms Max. 12 nodes/ 2 ms Max. 8 nodes/ 1ms
	Number of inverters in position mode/ Cycle time	Max. 8 nodes/ 4 ms Max. 8 nodes/ 2 ms Max. 8 nodes/ 1ms	Max. 4 nodes/ 4 ms Max. 4 nodes/ 2 ms Max. 4 nodes/ 1ms
	Transmission distance	Max. 50 meters without using repeater	
Data exchange with PLC	CJ1W-MCH72 exchanges data with memory areas in the PLC. Mapping for cyclic data exchange in the PLC CPU to memory areas in the motion unit can be freely configured.		

Notes: *1 It includes a maximum of 8 inverters in position mode.

*2 It includes inverters in position mode.

Nomenclature

CJ1W-MC□72 - Trajexia motion control unit

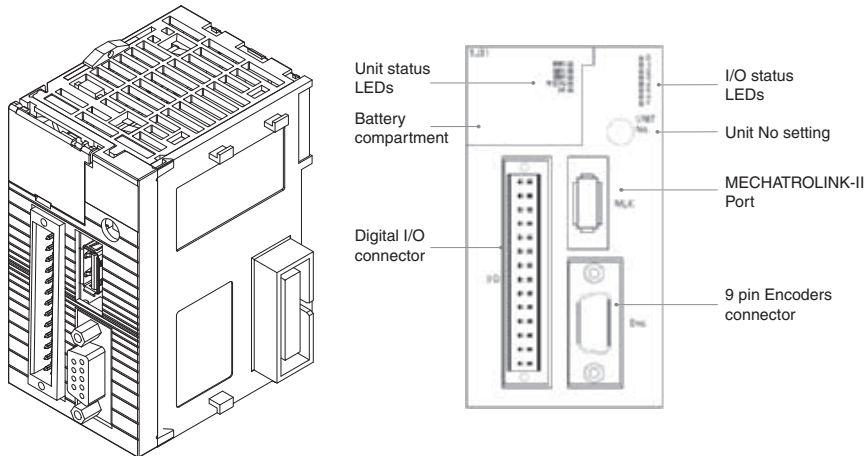

JEPMC-REP2000 - MECHATROLINK-II repeater

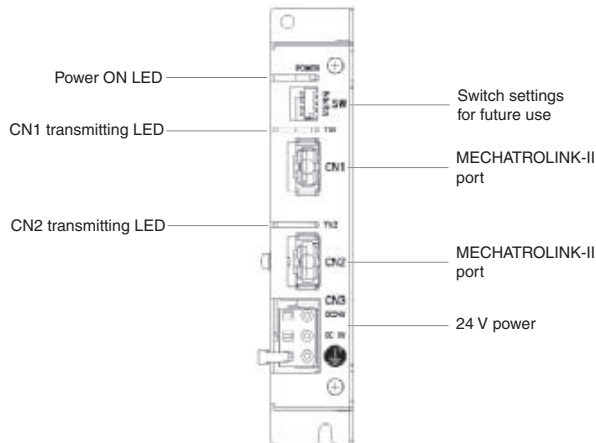

Dimensions

CJ1W-MC□72 - Trajexia motion control unit

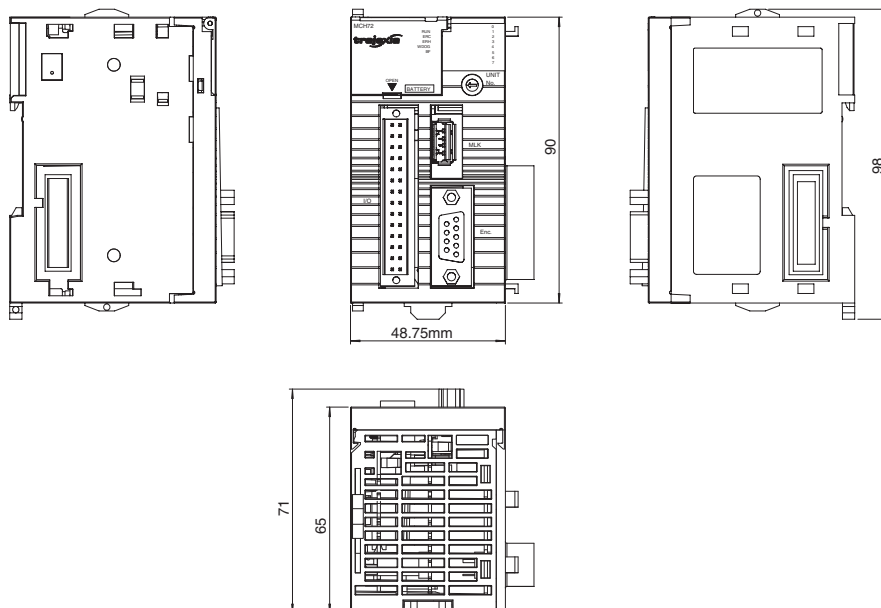

JEPMC-REP2000 - MECHATROLINK-II repeater

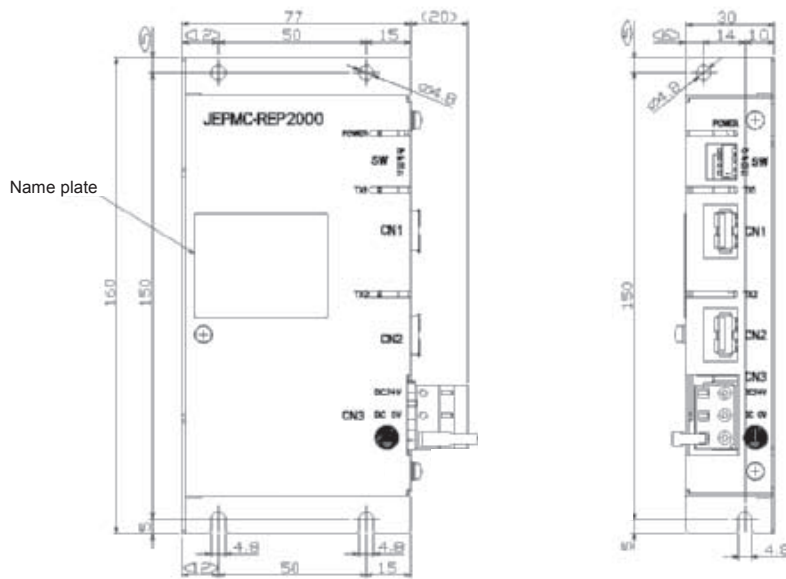

Ordering information

Motion controller

Name	Model
Trajexia motion control unit, up to 30 MECHATROLINK-II axes	CJ1W-MCH72
Trajexia motion control unit, up to 4 MECHATROLINK-II axes	CJ1W-MC472

MECHATROLINK-II - related devices

Servo system

Name	Model	
Accurax G5 servo drive ML-II built-in	R88D-KN□□□-ML2	
G-Series servo drive ML-II built-in	R88D-GN□□□H-ML2	
MX2 inverter with MECHATROLINK-II option board	Frequency inverter	3G3MX2-A□
	ML2 option board	3G3AX-MX2-MRT

Note: Refer to servo systems and frequency inverter sections for detailed specs and ordering information

MECHATROLINK-II cables

Name	Remarks	Model
MECHATROLINK-II cables	0.5 meter	JEPMC-W6003-A5
	1 meter	JEPMC-W6003-01
	3 meters	JEPMC-W6003-03
	5 meters	JEPMC-W6003-05
	10 meters	JEPMC-W6003-10
	20 meters	JEPMC-W6003-20
	30 meters	JEPMC-W6003-30
MECHATROLINK-II terminator	Terminating resistor	JEPMC-W6022
MECHATROLINK-II repeater	Network repeater	JEPMC-REP2000

Computer software

Specifications	Model
CX-Motion Pro V1.3.3 or higher	CX-One
Trajexia Studio ^{*1} V1.3.3 or higher	TJ1-Studio

*1. When the Trajexia Studio software is included in CX-One, then it is called CX-Motion Pro.

ALL DIMENSIONS SHOWN ARE IN MILLIMETERS.
To convert millimeters into inches, multiply by 0.03937. To convert grams into ounces, multiply by 0.03527.

CJ1W-NC271/471/F71 - NC MECHATROLINK-II

Position control unit

Multi-axis point-to-point positioning controller over MECHATROLINK-II Motion Bus

- Position control units with 2, 4 or 16 axes.
- High-speed bus MECHATROLINK-II is specially designed for motion control.
- Supports position, speed and torque control.
- Programming languages: ladder, function blocks. Supports PLC Open Function Blocks.
- Smart active parts for OMRON HMI's terminals reduce engineering time.
- Access to the complete system from one point. Network setup, servo drives configuring and monitoring, and PLC programming.



System configuration

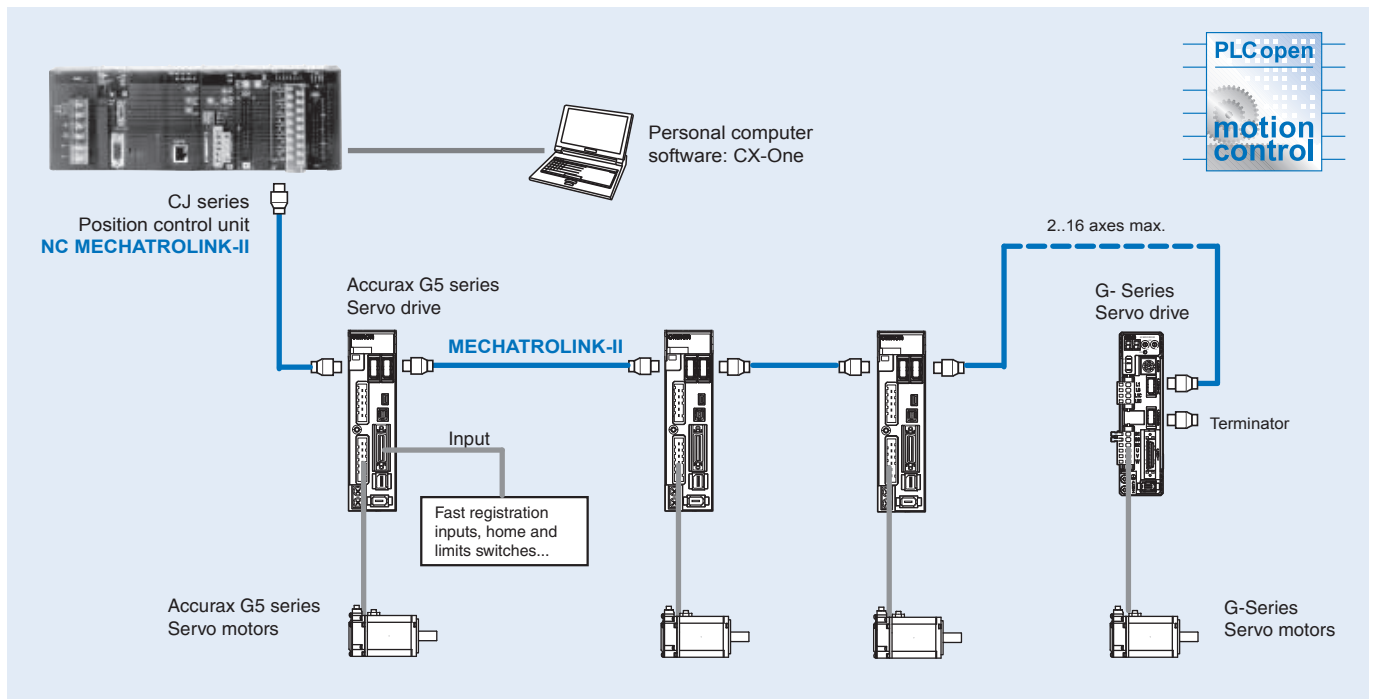

Specifications

Position control unit

Model	CJ1W-NC271	CJ1W-NC471	CJ1W-NCF71
Classification	CJ-series CPU bus unit		
Applicable PLCs	CJ-series CJ-series V. 3.0 or later in order to use function blocks (recommended CJ1G-CPU45 or CJ1H-CPU□)		
Possible unit number settings	0 to F		
Control method	MECHATROLINK-II (position, speed and torque control)		
Controlled devices	Accurax G5 and G-Series servo drives with MECHATROLINK-II built-in		
Controlled axes	2 maximum	4 maximum	16 maximum
I/O allocations	Common operating memory area	Words allocated in CPU bus unit area: 25 words (15 output words, 10 input words)	
	Axis operating memory area	Allocated in one of the following areas (user-specified): CIO, work, auxiliary, holding, DM, or EM area. Number of words allocated: 50 words (25 output words, 25 input words) × highest axis No. used	
Control units	Position command unit	Command unit: depends on the electronic gear setting in the servo parameters. Default setting: pulses	
	Speed command unit for position control	Command units/s	
	Acceleration/deceleration speeds for position control	10,000 command units/s ²	
	Speed command unit for speed control	0.001% of the motor's maximum speed	
	Torque command unit for torque control	0.001% of the motor's maximum torque	
Control command range	Position command range	-2,147,483,648 to 2,147,483,647 (command units)	
	Speed command range for position control	0 to 2,147,483,647 (command units/s)	
	Acceleration/deceleration speeds for position control	1 to 65,535 (10,000 command units/s ²)	
	Speed command range for speed control	-199.999% to 199.999% The upper limit is restricted by the maximum speed of the servo motor.	
	Torque command range for torque control	-199.999% to 199.999% The upper limit is restricted by the maximum torque of the servo motor.	
Control functions	Servo lock/unlock	Locks and unlocks the servo drive.	
	Position control	Positions to an absolute position or relative position according to the specified target position and target speed specified from the ladder program.	
	Origin determination	<ul style="list-style-type: none"> • Origin search: establishes the origin using the specified search method. • Present position preset: changes the present position to a specified position to establish the origin. • Origin return: returns the axis from any position to the established origin. • Absolute encoder origin: establishes the origin using a servo motor that has an absolute encoder, without having to use an origin search. 	
	Jogging	Outputs a fixed speed in the CW or CCW direction.	
	Interrupt feeding	Performs positioning by moving the axis a fixed amount when an external interrupt input is received while the axis is moving.	
	Speed control	Performs speed control by sending a command to the servo drive speed loop.	
	Torque control	Performs torque control by sending a command to the servo drive current loop.	
	Stop functions	<ul style="list-style-type: none"> • Deceleration stop: decelerates the moving axis to a stop. • Emergency stop: positions the moving axis for the number of pulses remaining in the deviation counter and then stops the axis. 	
	Linear interpolation	Up to 8 axes can be interpolated by using two interpolators (4 axes per interpolator) Available in unit version 1.1 or higher	
	Auxiliary functions	Acceleration/deceleration curves	Sets either a trapezoidal (linear) curve, an exponential curve, or an S-curve (moving average).
Torque limit		Restricts the torque upper limit during position control.	
Override		Multiplies the axis command speed by a specified ratio. Override: 0.01% to 327.67%	
Servo parameter transfer		Reads and writes the servo drive parameters from the ladder program in the CPU unit.	
Monitoring function		Monitors the control status of the servo drive's command coordinate positions, feedback position, current speed, torque, etc.	
Software limits		Limits software operation for controlling positioning.	
Backlash compensation		Compensates for the amount of play in the mechanical system according to a set value.	
External I/O	Deviation counter reset	The position deviation in the servo drive's deviation counter can be reset to 0 (unit version 1.3 or later).	
	Position control unit	One MECHATROLINK-II interface port	
Programming methods	Servo drive I/O	CW/CCW limit inputs, origin proximity inputs, external interrupt inputs 1 to 3 (can be used as external origin inputs)	
	Standard ladder	Directly over NCF unit memory area	
	Function blocks	Using standard PLC open function blocks	
Smart active parts			
Internal current consumption	360 mA or less at 5 VDC		
Weight	95 g		

Nomenclature

CJ1W-NC271/471/F71 - position control unit

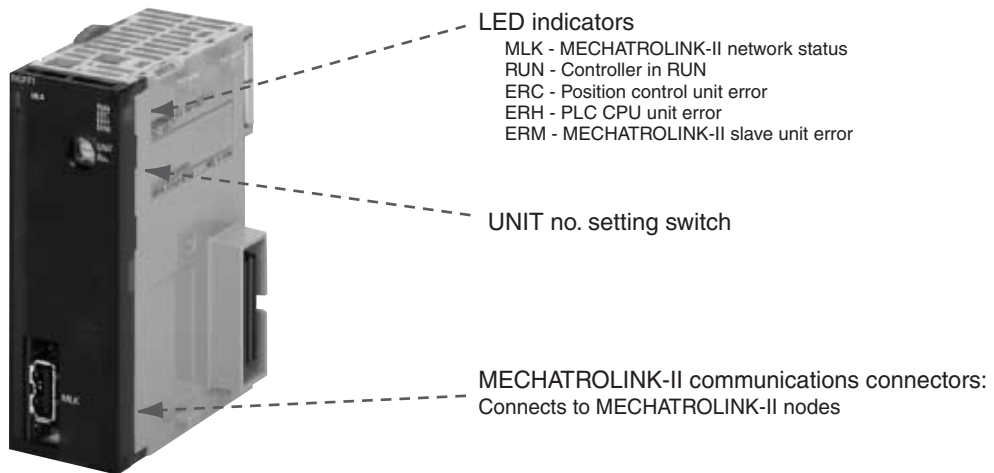

Dimensions

CJ1W-NC271/471/F71 - position control unit

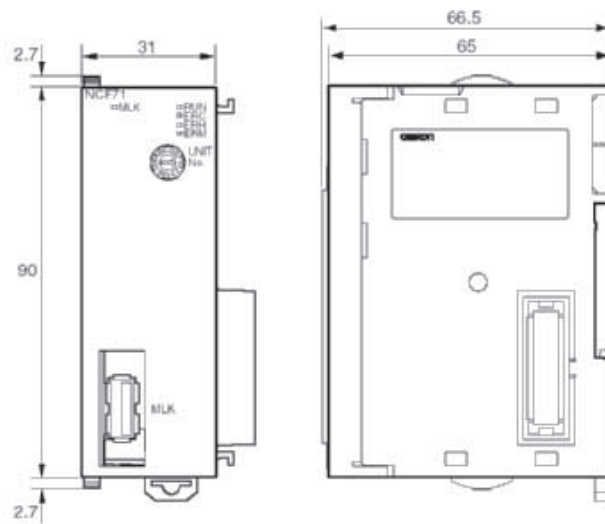

Ordering information

Position controller unit

Name	Model
MECHATROLINK-II position controller unit - 16 axes	CJ1W-NCF71
MECHATROLINK-II position controller unit - 4 axes	CJ1W-NC471
MECHATROLINK-II position controller unit - 2 axes	CJ1W-NC271

MECHATROLINK-II related devices

Servo system

Name	Model
Accurax G5 servo drive ML-II built-in	R88D-KN□□□-ML2
G-Series servo drive ML-II built-in	R88D-GN□□□H-ML2

Note: Refer to servo systems section for detailed specs and ordering information

MECHATROLINK-II cables

Name	Remarks	Model
MECHATROLINK-II terminator	Terminating resistor	JEPMC-W6022
MECHATROLINK-II cables	0.5 meter	JEPMC-W6003-A5
	1 meter	JEPMC-W6003-01
	3 meters	JEPMC-W6003-03
	5 meters	JEPMC-W6003-05
	10 meters	JEPMC-W6003-10
	20 meters	JEPMC-W6003-20
	30 meters	JEPMC-W6003-30

Computer software

Specifications	Model
CX-One version 2.0 (CX-Motion NCF 1.70 or higher) CX-One version 3.0 (CX-Motion NCF 1.90 or higher) CX-One version 4.0 or higher	CX-One

ALL DIMENSIONS SHOWN ARE IN MILLIMETERS.
To convert millimeters into inches, multiply by 0.03937. To convert grams into ounces, multiply by 0.03527.

CJ1W-NC□□3

Position control unit

Point-to-point positioning controller with pulse train output

- Position control units with 1, 2 or 4 axes
- Positioning can done by direct ladder commands
- Position and speed control
- Linear interpolation
- Interrupt feeding function
- Positioning of 100 points done from memory
- S-curve acceleration/deceleration, origin search, backlash compensation, and other features are also supported.
- Positioning data is saved in internal flash memory, eliminating the need to maintain a backup battery.
- Use Windows-based support software (CX-position) to easily create positioning data and store data and parameters in files.



Function

These position control units support positioning control via pulse-train outputs. Positioning is performed using trapezoidal or S-curve acceleration and deceleration. Models are available with 1, 2, or 4 axes control, and can be used in combination with servo drives or stepping motors what accept pulse-train control.

System configuration

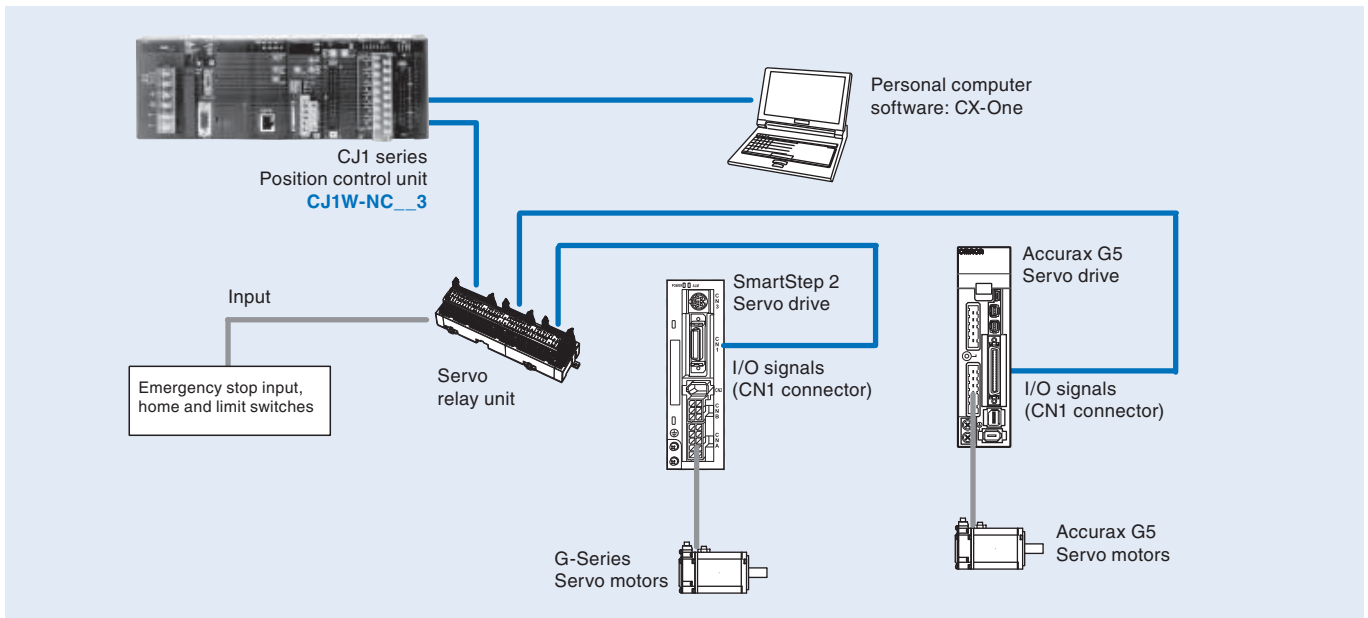

Specifications

Model	CJ1W-NC113 CJ1W-NC133	CJ1W-NC213 CJ1W-NC233	CJ1W-NC413 CJ1W-NC433
Unit name	Position control unit		
Classification	Special I/O unit		
Unit numbers	0 to 95		0 to 94
Control method	Open-loop control by pulse train output		
Control output interface	CJ1W-NC□13: Open-collector output CJ1W-NC□33: Line-driver output		
Controlled axes	1	2	4
Operating modes	Direct operation or memory operation		
Data format	Binary (hexadecimal)		
Affect on scan time for end refresh	0.29 to 0.41 ms max./unit		
Affect on scan time for IOWR/IORD	0.6 to 0.7 ms max./instructions		
Startup time	2 ms max. (refer to operation manual for conditions)		
Position data	-1,073,741,823 to +1,073,741,823 pulses		
No. of positions	100 per axis		
Speed data	1 to 500 kpps (in 1 pps units)		
No. of speeds	100 per axis		
Acceleration/deceleration times	0 to 250 s (time to max. speed)		
Acceleration/deceleration curves	Trapezoidal or S-curve		
Saving data in CPU	Flash memory		
Windows-based support software	CX-position (WS02-NCTC1-E)		
Ambient operating temperature	0 to 55°C		0 to 50°C
External power supply	24 VDC ±10%, 5 VDC ±5% (line driver only)		24 VDC ±5%, 5 VDC ±5% (line driver only)

Nomenclature

Position control unit

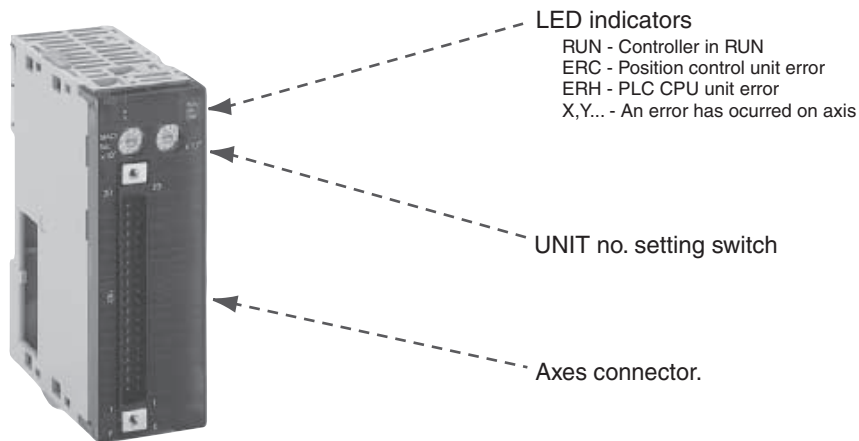

Dimensions

Position control unit

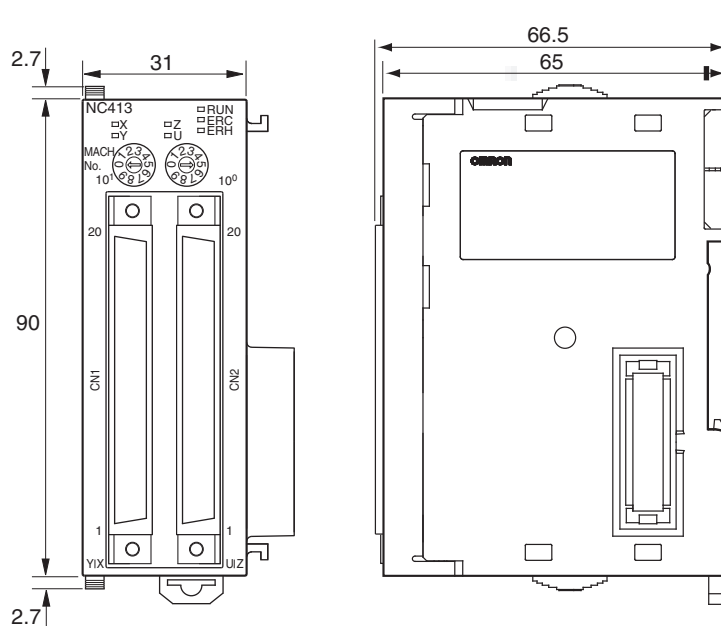

Ordering information

Position control unit

Name	Model
1 axis position control unit. Open-collector output.	CJ1W-NC113
2 axes position control unit. Open-collector output.	CJ1W-NC213
4 axes position control unit. Open-collector output.	CJ1W-NC413
1 axis position control unit. Line-driver output.	CJ1W-NC133
2 axes position control unit. Line-driver output.	CJ1W-NC233
4 axes position control unit. Line-driver output.	CJ1W-NC433

Servo drive cables

Note: Refer the selected servo systems section for cable and servo relay units information.

Computer software

Specifications	Model
CX-One	CX-One

ALL DIMENSIONS SHOWN ARE IN MILLIMETERS.

To convert millimeters into inches, multiply by 0.03937. To convert grams into ounces, multiply by 0.03527.

CJ1W-NC□□4

Position control unit

Point-to-point positioning controller with pulse train output and motion control unit functionality

- Position control units with 2 or 4 axes
- Position and speed control
- Linear interpolation and feeder control function
- Electronic CAM profiles and axes synchronization
- Positioning of 500 points per axis done from memory
- S-curve acceleration/deceleration, origin search, backlash compensation, and other features are also supported.
- Programming languages: ladder, function blocks.
- Use Windows-based support software to easily create positioning data and store data and parameters in files.



Function

These position control units support positioning control via pulse-train outputs. Positioning is performed using trapezoidal or S-curve acceleration and deceleration. Models are available with 2 or 4 axes control, and can be used in combination with servo drives or stepping motors what accept pulse-train control. When these units are used in a CJ2 PLC CPU can perform also synchronous operation by use of electronic CAMs and other function blocks.

System configuration

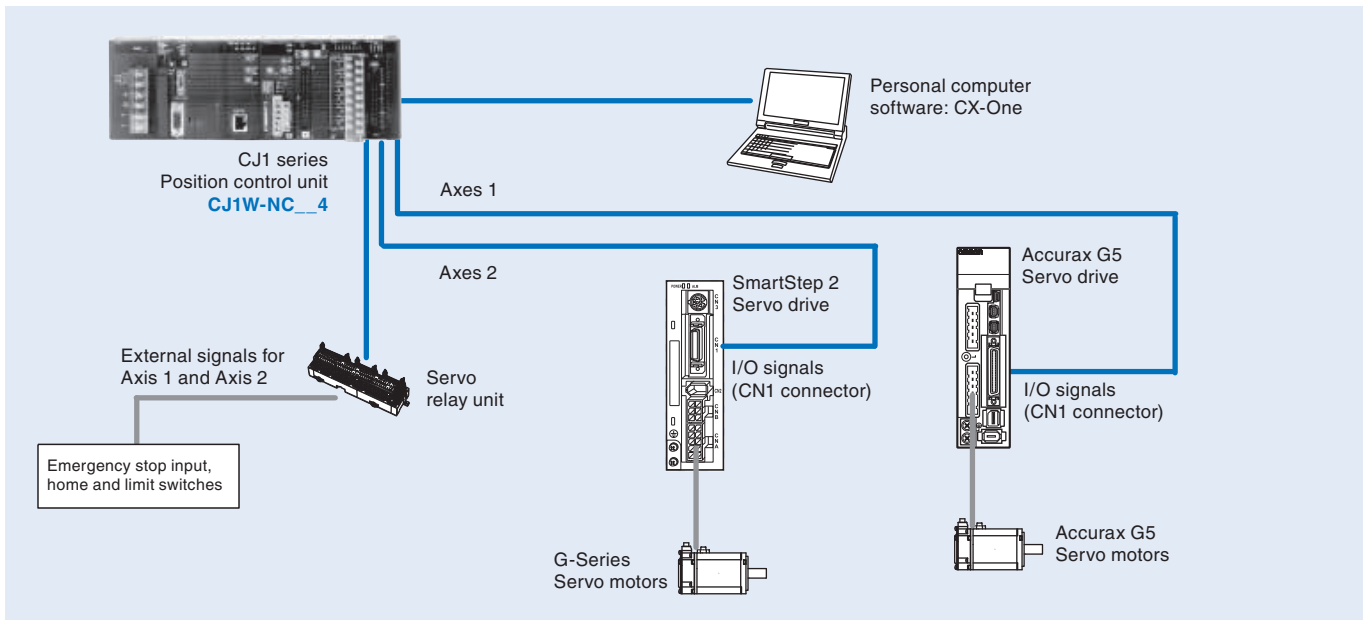

Specifications

Model		CJ1W-NC214 CJ1W-NC234	CJ1W-NC414 CJ1W-NC434
Unit name		Position control unit	
Classification		CJ series special I/O units	
Applicable PLCs		CJ series	
Unit numbers		0 to 94	
Maximum number of units per rack		5 units	
Maximum number of units per CJ system		20 units (3 expansion racks maximum)	
Occupied unit		2	
Control method		Open-loop control by pulse train output	
Control output signals		CJ1W-NC□14: Open-collector output CJ1W-NC□34: Line-driver output	
Controlled axes		2	4
I/O allocations		Allocated in one of the following areas(user-specified): CIO, WR, HR, DM or EM area.	
Control function	Operating modes	Direct operation or memory operation	
	Linear interpolation	2 axes maximum	4 axes maximum
	Circular interpolation	2 axes maximum	
	Interrupt feeding	Independent, 2 axes	Independent, 4 axes
	Position data	-2147483648 to +2147483647	
	No. of positions	500 per axis	
	Speed data	4 Mpps maximum speed (NC234/434) or 500 kpps (NC214/414)	
	No. of speeds	500 per axis	
	Acceleration/deceleration times	0 to 250 s (time to max. speed)	
Auxiliary functions	Acceleration/deceleration curves	Trapezoidal or S-curve	
	Override	Multiplies the axis command speed by a specified ratio. Value: 0.01% to 500.00%	
	Software limits	Limits software operation for controlling positioning	
	Backlash compensation	Compensates for the amount of play in the mechanical system according to a set value	
	Torque limit	Restricts the torque upper limit during position control	
Saving data in PCU		Flash memory	
Ambient operating temperature		0 to 55°C	
External power supply		24 VDC	
Internal current consumption		270 mA or less at 5 VDC	310 mA or less at 5 VDC
Weight		170 g	220 g

Nomenclature

CJ1W-NC214/234/414/434 - position control unit

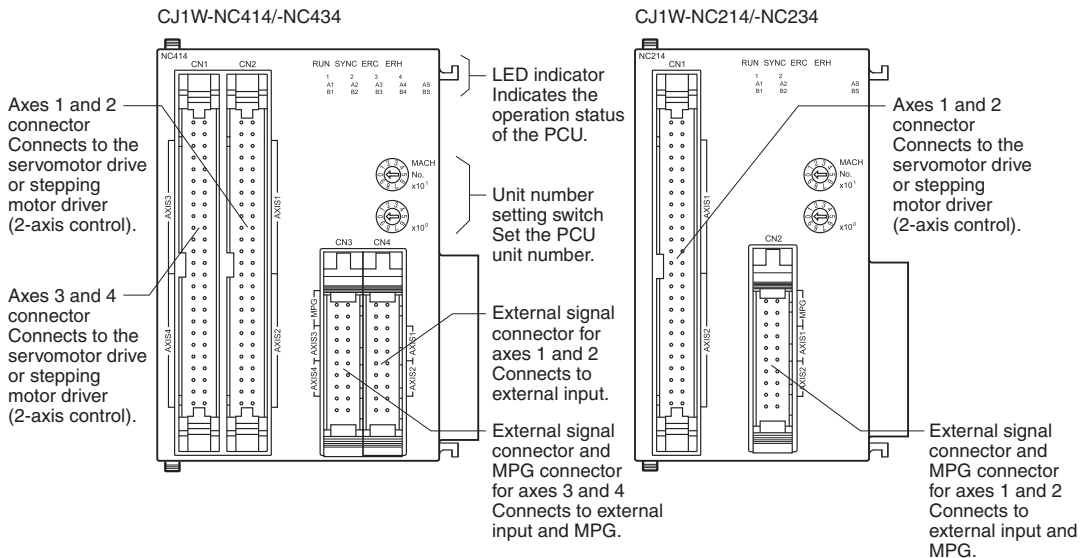

Dimensions

CJ1W-NC214/234/414/434 - position control unit

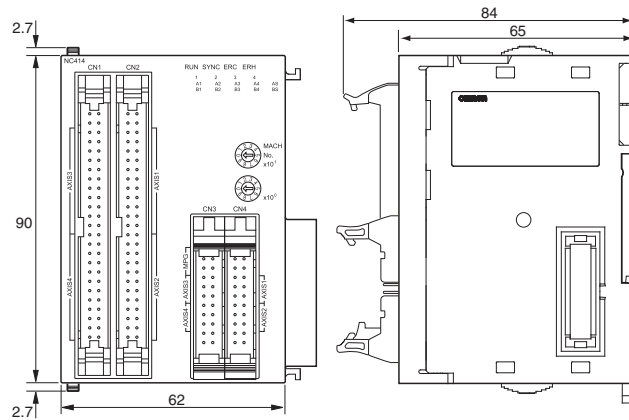
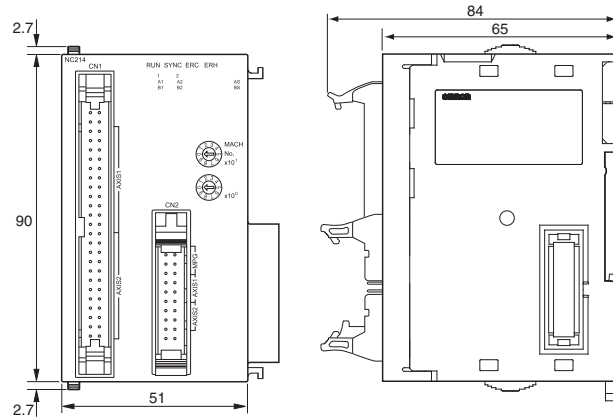

Ordering information

Position control unit

Name	Model
2 axes position control unit. Open-collector output.	CJ1W-NC214
4 axes position control unit. Open-collector output.	CJ1W-NC414
2 axes position control unit. Line-driver output.	CJ1W-NC234
4 axes position control unit. Line-driver output.	CJ1W-NC434

Servo drive cables

Note: Refer to selected servo systems section for cable and servo relay units information.

Computer software

Specifications	Model
CX-One version 4.0 or higher	CX-One

ALL DIMENSIONS SHOWN ARE IN MILLIMETERS.
 To convert millimeters into inches, multiply by 0.03937. To convert grams into ounces, multiply by 0.03527.

AC Servo systems

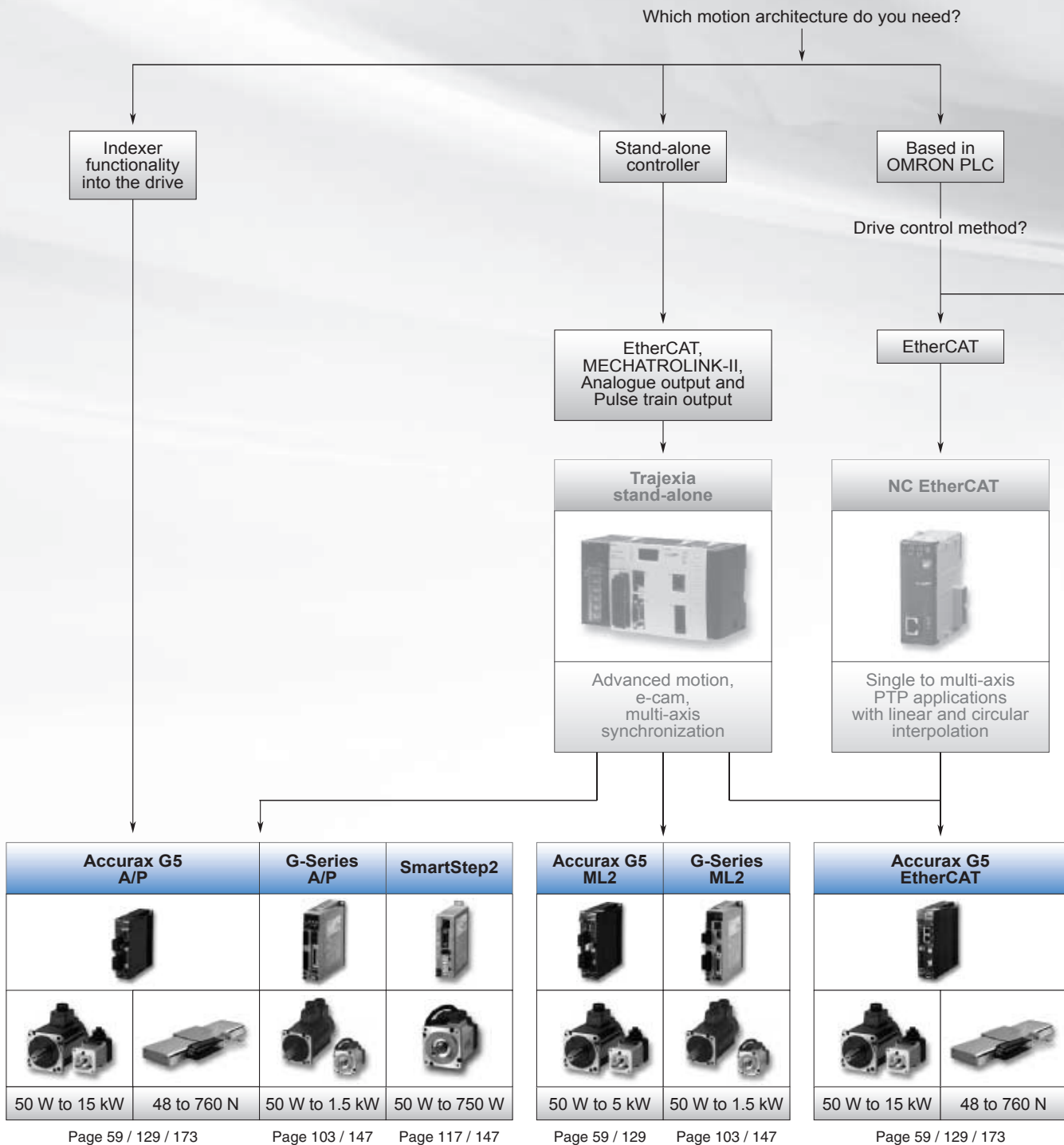
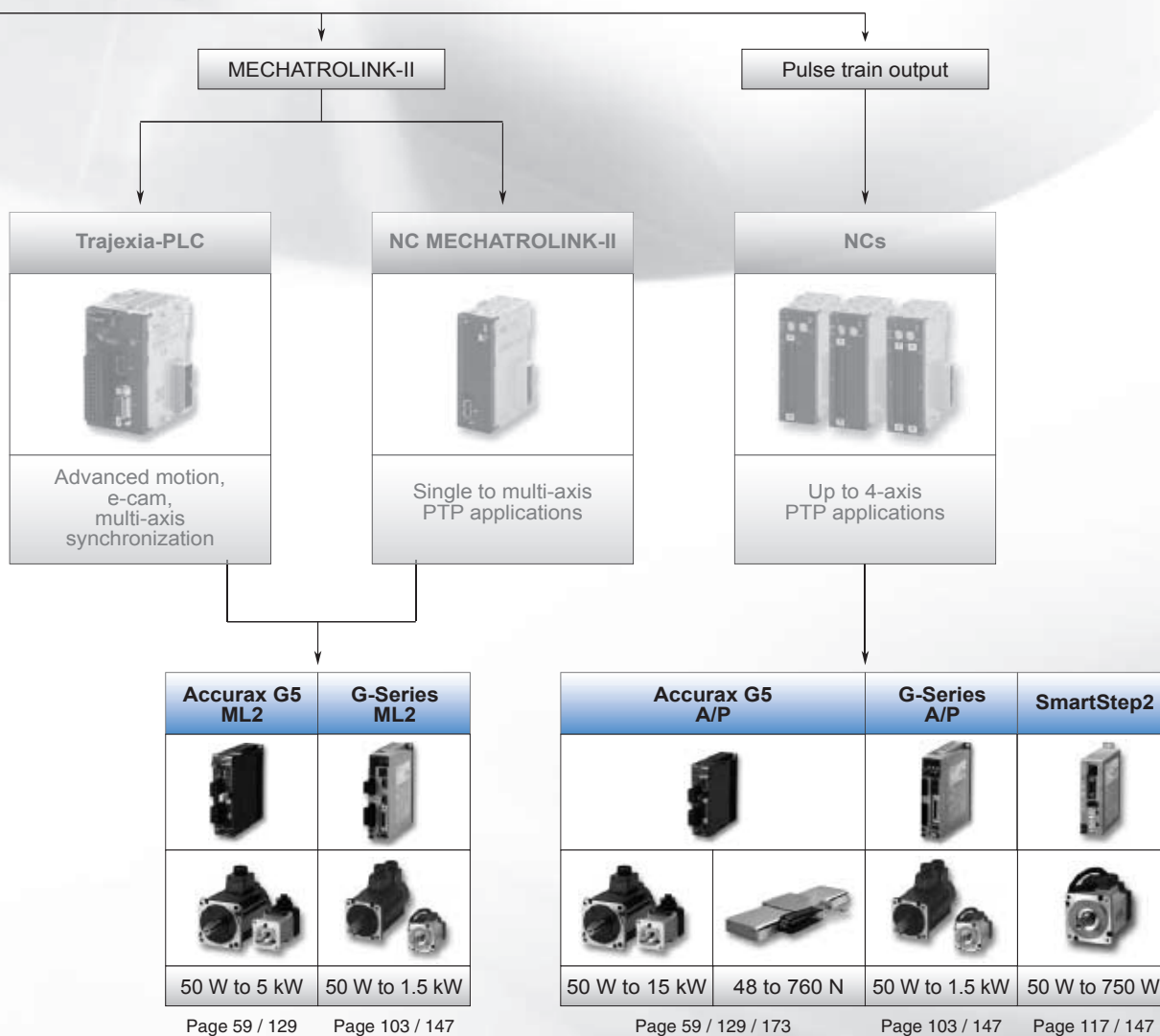









Table of contents





Selection table		56
Servo drives	Accurax G5 rotary drive	59
	Accurax G5 linear drive	83
	G-Series	103
	SmartStep 2	117
Rotary servo motors	Accurax G5	129
	G-Series	147
Linear servo motors	Accurax linear motor	157
	Accurax linear motor axis	173





Selection table

Servo drives			
			
	Accurax G5	G-Series	SmartStep 2
	EtherCAT network and safety built-in	Compact size and ML2 motion bus	Pulse train input with ultra-compact size
Ratings 230 V single-phase	100 W to 1,5 kW	100 W to 1,5 kW	100 W to 750 W
Ratings 400 V three-phase	600 W to 15 kW	N/A	N/A
Applicable servomotor	Accurax G5 and G-Series rotary motors and Accurax linear motors	G-Series	G-Series
Position control	EtherCAT, MECHATROLINK-II or Pulse train input	MECHATROLINK-II or Pulse train input	Pulse train input
Speed control	EtherCAT, MECHATROLINK-II or Analogue input ± 10 V	MECHATROLINK-II or Analogue input ± 10 V	N/A
Torque control	EtherCAT, MECHATROLINK-II or Analogue input ± 10 V	MECHATROLINK-II or Analogue input ± 10 V	Torque limits only
Internal positioning	Embedded indexer functionality	N/A	N/A
Safety approvals	ISO13849-1:2008 (PL d), EN 954-1:1996 (Cat-3)	N/A	N/A
Full closed loop	Built-in	N/A	N/A
Page	59 / 83	103	117

Accurax G5 servo motors				
				
	3000 r/min motor	2000 r/min motor	1500 r/min motor	1000 r/min motor
Rated speed	3,000 rpm	2,000 rpm	1,500 rpm	1,000 rpm
Maximum speed	4,500 to 6,000 rpm	3,000 rpm	2,000 to 3,000 rpm	2,000 rpm
Rated torque	0.16 Nm to 15.9 Nm	1.91 Nm to 23.9 Nm	47.8 Nm to 95.5 Nm	8.59 Nm to 57.3 Nm
Sizes	50 W to 5 kW	400 W to 5 kW	7,5 kW to 15 kW	900 W to 6 kW
Applicable servo drive	Accurax G5 servo drive	Accurax G5 servo drive	Accurax G5 servo drive	Accurax G5 servo drive
Encoder resolution	20-bit incremental/ 17-bit absolute	20-bit incremental/ 17-bit absolute	17-bit absolute	20-bit incremental/ 17-bit absolute
IP rating	IP67	IP67	IP67	IP67
Page	129			

G-Series servo motors – Cylindrical type –				G-Series servo motors – Flat type –
				
	3000 r/min motor	2000 r/min motor	1000 r/min motor	3000 r/min motor
Rated speed	3,000 rpm	2,000 rpm	1,000 rpm	3,000 rpm
Maximum speed	4,500 to 5,000 rpm	3,000 rpm	2,000 rpm	5,000 rpm
Rated torque	0.16 Nm to 4.77 Nm	4.8 Nm to 7.15 Nm	8.62 Nm	0.32 Nm to 1.3 Nm
Sizes	50 to 1,500 W	1 to 1.5 kW	900 W	100 to 400 W
Applicable servo drive	SmartStep 2 , G-Series and Accurax G5 servo drives	SmartStep 2 , G-Series and Accurax G5 servo drives	SmartStep 2 , G-Series and Accurax G5 servo drives	SmartStep 2 , G-Series and Accurax G5 servo drives
Encoder resolution	10,000 pulses/revolution or 17-bit absolute/incremental	10,000 pulses/revolution or 17-bit absolute/incremental	10,000 pulses/revolution or 17-bit absolute/incremental	10,000 pulses/revolution or 17-bit absolute/incremental
IP rating	IP65	IP65	IP65	IP65
Page	147			

Accurax linear motors			
			
	Iron-core linear motors	Ironless linear motors	Linear motor axis
Continuous force range	48 N to 760 N	26.5 N to 348 N	48 N to 760 N
Peak force range	105 N to 2000 N	100 N to 2100 N	105 N to 2000 N
Maximum speed	1 to 10 m/s	1.2 to 16 m/s	5 m/s
Magnetic attraction force	300 N to 4440 N	Zero	300 N to 4440 N
Applicable servo drive	Accurax G5 linear drives	Accurax G5 linear drives	Accurax G5 linear drives
Page	157		173

R88D-KN□□□-ECT, R88D-KN□□□-ML2, R88D-KT□

Accurax G5 rotary drive

Accurate motion control in a compact size servo drive family. EtherCAT and safety built-in.

- EtherCAT, ML-II and Analog/ Pulse servo drive models
- Safety conforming ISO13849-1 PL-d
- High-response frequency of 2 kHz
- High resolution provided by 20 bits encoder
- Drive Programming: embedded indexer functionality in the Analogue/ Pulse models
- External encoder input for full closed loop
- Real time auto-tuning
- Advanced tuning algorithms (Anti-vibration function, torque feedforward, disturbance observer)

Ratings





- 230 VAC Single-phase 100 W to 1.5 kW (8.59 Nm)
- 400 VAC three-phase 600 W to 15 kW (95.5 Nm)

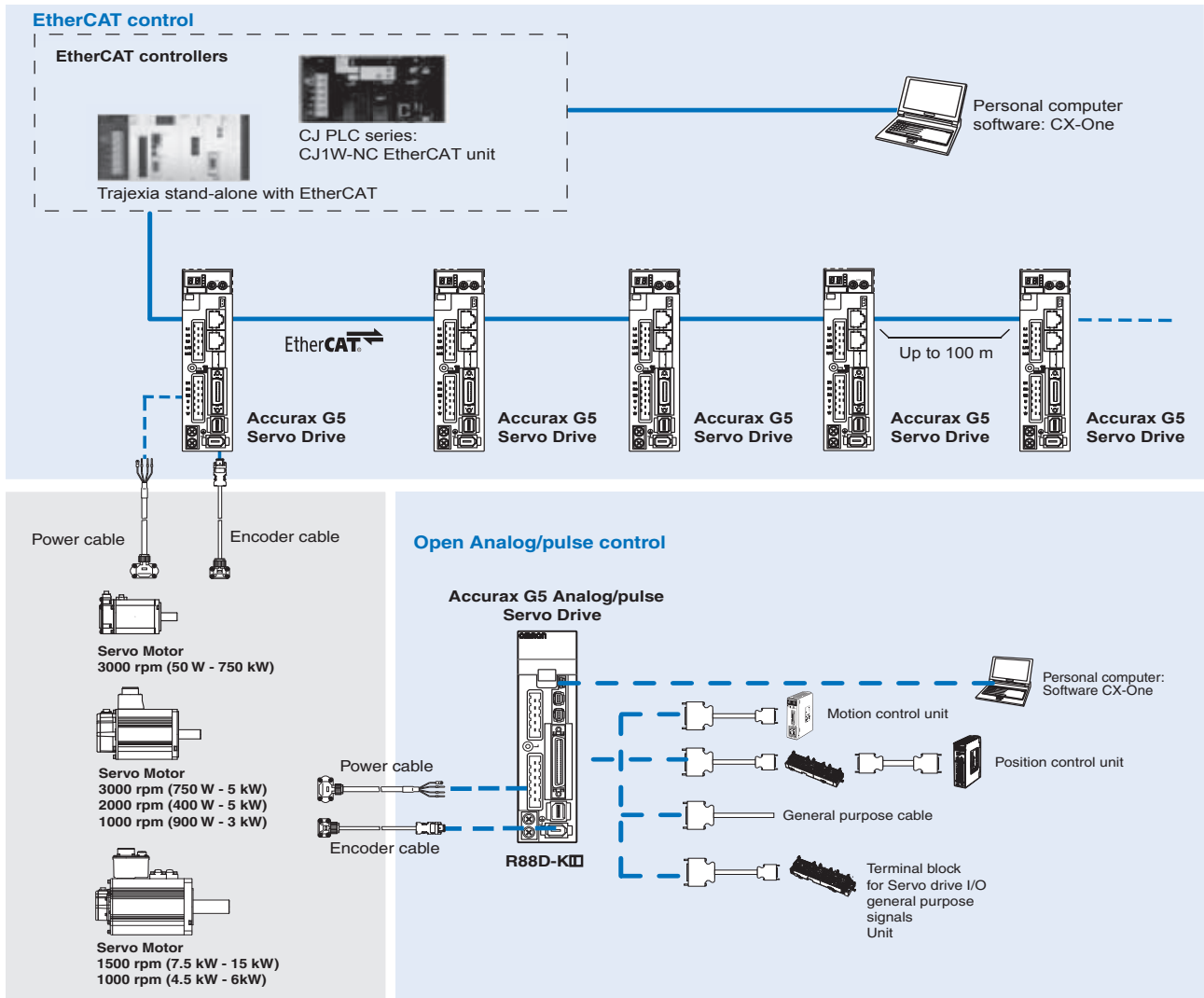

System configuration

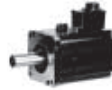

Servo motor supported

Accurax G5 rotary servo motor					Accurax G5 servodrive models			
	Voltage	Speed	Rated torque	Capacity	Model	EtherCAT	Analog/Pulse	MECHATROLINK-II
	230 V	3000 min ⁻¹	0.16 Nm	50 W	R88M-K05030(H/T)-□	R88D-KN01H-ECT	R88D-KT01H	R88D-KN01H-ML2
			0.32 Nm	100 W	R88M-K10030(H/T)-□	R88D-KN01H-ECT	R88D-KT01H	R88D-KN01H-ML2
			0.64 Nm	200 W	R88M-K20030(H/T)-□	R88D-KN02H-ECT	R88D-KT02H	R88D-KN02H-ML2
			1.3 Nm	400 W	R88M-K40030(H/T)-□	R88D-KN04H-ECT	R88D-KT04H	R88D-KN04H-ML2
			2.4 Nm	750 W	R88M-K75030(H/T)-□	R88D-KN08H-ECT	R88D-KT08H	R88D-KN08H-ML2
			3.18 Nm	1000 W	R88M-K1K030(H/T)-□	R88D-KN15H-ECT	R88D-KT15H	R88D-KN15H-ML2
			4.77 Nm	1500 W	R88M-K1K530(H/T)-□	R88D-KN15H-ECT	R88D-KT15H	R88D-KN15H-ML2
			2.39 Nm	750 W	R88M-K75030(F/C)-□	R88D-KN10F-ECT	R88D-KT10F	R88D-KN10F-ML2
			3.18 Nm	1000 W	R88M-K1K030(F/C)-□	R88D-KN15F-ECT	R88D-KT15F	R88D-KN15F-ML2
			4.77 Nm	1500 W	R88M-K1K530(F/C)-□	R88D-KN15F-ECT	R88D-KT15F	R88D-KN15F-ML2
	400 V	3000 min ⁻¹	6.37 Nm	2000 W	R88M-K2K030(F/C)-□	R88D-KN20F-ECT	R88D-KT20F	R88D-KN20F-ML2
			9.55 Nm	3000 W	R88M-K3K030(F/C)-□	R88D-KN30F-ECT	R88D-KT30F	R88D-KN30F-ML2
			12.7 Nm	4000 W	R88M-K4K030(F/C)-□	R88D-KN50F-ECT	R88D-KT50F	R88D-KN50F-ML2
			15.9 Nm	5000 W	R88M-K5K030(F/C)-□	R88D-KN50F-ECT	R88D-KT50F	R88D-KN50F-ML2
			4.77 Nm	1000 W	R88M-K1K020(H/T)-□	R88D-KN10H-ECT	R88D-KT10H	R88D-KN10H-ML2
			7.16 Nm	1500 W	R88M-K1K520(H/T)-□	R88D-KN15H-ECT	R88D-KT15H	R88D-KN15H-ML2
			1.91 Nm	400 W	R88M-K40020(F/C)-□	R88D-KN06F-ECT	R88D-KT06F	R88D-KN06F-ML2
			2.86 Nm	600 W	R88M-K60020(F/C)-□	R88D-KN06F-ECT	R88D-KT06F	R88D-KN06F-ML2
			4.77 Nm	1000 W	R88M-K1K020(F/C)-□	R88D-KN10F-ECT	R88D-KT10F	R88D-KN10F-ML2
			7.16 Nm	1500 W	R88M-K1K520(F/C)-□	R88D-KN15F-ECT	R88D-KT15F	R88D-KN15F-ML2
	230 V	2000 min ⁻¹	9.55 Nm	2000 W	R88M-K2K020(F/C)-□	R88D-KN20F-ECT	R88D-KT20F	R88D-KN20F-ML2
			14.3 Nm	3000 W	R88M-K3K020(F/C)-□	R88D-KN30F-ECT	R88D-KT30F	R88D-KN30F-ML2
			19.1 Nm	4000 W	R88M-K4K020(F/C)-□	R88D-KN50F-ECT	R88D-KT50F	R88D-KN50F-ML2
			23.9 Nm	5000 W	R88M-K5K020(F/C)-□	R88D-KN50F-ECT	R88D-KT50F	R88D-KN50F-ML2
			47.8 Nm	7500 W	R88M-K7K515C-□	R88D-KN75F-ECT	R88D-KT75F	-
	400 V	2000 min ⁻¹	70.0 Nm	11000 W	R88M-K11K015C-□	R88D-KN150F-ECT	R88D-KT150F	-
			95.5 Nm	15000 W	R88M-K15K015C-□	R88D-KN150F-ECT	R88D-KT150F	-
			8.59 Nm	900 W	R88M-K90010(H/T)-□	R88D-KN15H-ECT	R88D-KT15H	R88D-KN15H-ML2
			8.59 Nm	900 W	R88M-K90010(F/C)-□	R88D-KN15F-ECT	R88D-KT15F	R88D-KN15F-ML2
			19.1 Nm	2000 W	R88M-K2K010(F/C)-□	R88D-KN30F-ECT	R88D-KT30F	R88D-KN30F-ML2
230 V	1000 min ⁻¹	28.7 Nm	3000 W	R88M-K3K010(F/C)-□	R88D-KN50F-ECT	R88D-KT50F	R88D-KN50F-ML2	
		43.0 Nm	4500 W	R88M-K4K510C-□	R88D-KN50F-ECT	R88D-KT50F	R88D-KN50F-ML2	
		57.3 Nm	6000 W	R88M-K6K010C-□	R88D-KN75F-ECT	R88D-KT75F	-	
		57.3 Nm	6000 W	R88M-K6K010C-□	R88D-KN75F-ECT	R88D-KT75F	-	
	400 V	1000 min ⁻¹	8.59 Nm	900 W	R88M-K90010(H/T)-□	R88D-KN15H-ECT	R88D-KT15H	R88D-KN15H-ML2
			8.59 Nm	900 W	R88M-K90010(F/C)-□	R88D-KN15F-ECT	R88D-KT15F	R88D-KN15F-ML2
			19.1 Nm	2000 W	R88M-K2K010(F/C)-□	R88D-KN30F-ECT	R88D-KT30F	R88D-KN30F-ML2
			28.7 Nm	3000 W	R88M-K3K010(F/C)-□	R88D-KN50F-ECT	R88D-KT50F	R88D-KN50F-ML2

Type designation

Servo drive

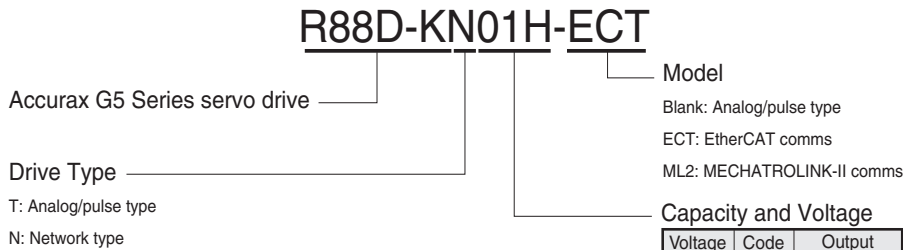

Servo drive specifications

Single-phase, 230 V

Servo drive type		R88D-K□	01H□	02H□	04H□	08H□	10H□	15H□
Applicable servo motor	R88M-K□	05030(H/T)□	20030(H/T)□	40030(H/T)□	75030(H/T)□	1K020(H/T)□	1K030(H/T)□	
		10030(H/T)□	-	-	-	-	1K530(H/T)□	
		-	-	-	-	-	1K520(H/T)□	
		-	-	-	-	-	90010(H/T)□	
Max. applicable motor capacity	W	100	200	400	750	1000	1500	
Continuous output current	Arms	1.2	1.6	2.6	4.1	5.9	9.4	
Input power	Main circuit	Single-phase/3-phase, 200 to 240 VAC + 10 to -15% (50/60 Hz)						
Supply	Control circuit	Single-phase, 200 to 240 VAC + 10 to -15% (50/60 Hz)						
Control method		IGBT-driven PWM method, sinusoidal drive						
Feedback		Serial encoder (incremental/absolute value)						
Conditions	Usage/storage temperature	0 to +55°C / -20 to 65°C						
	Usage/storage humidity	90% RH or less (non-condensing)						
	Altitude	1000m or less above sea level						
Vibration/shock resistance (max.)		5.88 m/s ² 10-60 Hz (Continuous operation at resonance point is not allowed) / 19.6 m/s ²						
Configuration		Base mounted						
Approx. weight	Kg	0.8		1.1	1.6		1.8	

Three-phase, 400 V

Servo drive type		R88D-K□	06F-□	10F-□	15F-□	20F-□	30F-□	50F-□	75F-□	150F-□
Applicable servo motor	R88M-K□	40020(F/C)-□	75030(F/C)-□	1K030(F/C)-□	2K030(F/C)-□	3K030(F/C)-□	4K030(F/C)-□	6K010C-□	11K015C-□	
		60020(F/C)-□	1K020(F/C)-□	1K530(F/C)-□	2K020(F/C)-□	3K020(F/C)-□	5K030(F/C)-□	7K515C-□	15K015C-□	
		-	-	1K520(F/C)-□	-	2K010(F/C)-□	4K020(F/C)-□	-	-	
		-	-	90010(F/C)-□	-	-	5K020(F/C)-□	-	-	
		-	-	-	-	-	4K510C-□	-	-	
Max. applicable motor capacity	kW	0.6	1.0	1.5	2.0	3.0	5.0	7.5	15.0	
Continuous output current	Arms	1.5	2.9	4.7	6.7	9.4	16.5	22.0	33.4	
Input power	Main circuit	3-phase, 380 to 480 VAC + 10 to -15% (50/60Hz)								
Supply	Control circuit	24 VDC ±15%								
Control method		IGBT-driven PWM method, sinusoidal drive								
Feedback	Serial encoder	Incremental or absolute encoder						Absolute encoder		
Conditions	Usage/storage temperature	0 to +55°C / -20 to +65°C								
	Usage/storage humidity	90% RH or less (non-condensing)								
	Altitude	1000 m or less above sea level								
Vibration/shock resistance		5.88 m/s ² 10-60 Hz (Continuous operation at resonance point is not allowed) / 19.6 m/s ²								
Configuration		Base mounted								
Approx. weight	Kg		1.9		2.7		4.7		13.5	21.0

General specifications (for EtherCAT servo drives)

Performance		Frequency characteristics	2 kHz	
EtherCAT interface	Command input		EtherCAT commands (for sequence, motion, data setting/reference, monitor, adjustment, and other commands).	
	*1 Drive Profile		CSP, CSV, CST, Homing and Position Profile modes (CiA402 Drive Profile) Homing mode Position profile mode Dual touch probe function (Latch function) Torque limit function	
I/O signal	Sequence input signal		- Multi-function input x 8 by parameter setting (forward/reverse drive prohibition, emergency stop, external latch, origin proximity, forward/reverse torque limit, general purpose monitor input).	
	Sequence output signal		1 x servo drive error output 2 x multi-function outputs by parameters setting (servo ready, brake release, torque limit detection, zero speed detection, warning output, position completion, error clear attributed, programmable output...)	
Integrated functions	USB communications	Interface	Personal computer/ Connector mini-USB	
		Communications standard	Compliant with USB 2.0 standard	
		Function	Parameter setting, status monitoring and tuning	
	EtherCAT communications	Communications protocol	IEC 61158 Type 12, IEC 61800-7	
		Physical layer	100BASE-TX (IEEE802.3)	
		Connectors	RJ45 x 2 ECAT IN: EtherCAT input x 1 ECAT OUT: EtherCAT output x 1	
		Communications media	Category 5 or higher(cable with double, aluminium tape and braided shielding is recommended)	
		Communications distance	Distance between nodes: 100 m max.	
		LED indicators	RUN x 1 ERR x 1 L/A IN (Link/Activity IN) x 1 L/A OUT (Link/activity OUT) x 1	
	Autotuning		Automatic motor parameter setting. One parameter rigidity setting. Inertia detection.	
	Dynamic brake (DB)		Built-in. Operates during main power OFF, servo alarm, servo OFF or overtravel.	
	Regenerative processing		Internal resistor included in models from 600 W to 5 kW. Regenerative resistor externally mounted (option).	
	Overtravel (OT) prevention function		DB stop, deceleration stop or coast to stop during P-OT, N-OT operation	
Encoder divider function		Gear ratio		
Protective functions		Overcurrent, overvoltage, undervoltage, overspeed, overload, encoder error, overheat...		
Analog monitor functions for supervision		Analog monitor of motor speed, speed reference, torque reference, command following error, analog input... The monitoring signals to output and their scaling can be specified with parameters. Number of channels: 2 (Output voltage: ±10V DC)		
Panel operator	Display functions	2 x digit 7-segment LED display shows the drive status, alarm codes, parameters...		
	Switches	2 x rotary switches for setting the node address		
CHARGE lamp		Lits when the main circuit power supply is turned ON.		
Safety terminal	Functions	Safety Torque OFF function to cut off the motor current and stop the motor. Output signal for failure monitoring function.		
	Conformed standards	EN ISO13849-1:2008 (PL- d, Performance Level d), IEC61800-5 -2:2007 (function STO, Safe Torque OFF), EN61508:2001 (Safety Integrity Level 2, SIL2), EN954-1:1996 (CAT3).		
External encoder feedback		Serial signal and line-driver A-B-Z encoder for full-closed control		

*1 The CSV, CST and Homing modes are supported in the servo drive with version 2.0 or higher.

General specifications (for MECHATROLINK-II servo drives)

Control mode		Position control, velocity control, torque control, full-closed control.	
Performance	Frequency characteristics	2 kHz	
	Speed zero clamp	Preset velocity command can be clamped to zero by the speed zero clamp input.	
	soft start time setting	0 to 10 s (acceleration, deceleration can be set separately).	
Command input	MECHATROLINK-II communication	MECHATROLINK-II commands (for sequence, motion, data setting/reference, monitor, adjustment and other commands)	
I/O signal	Sequence input signal	- Multi-function input x 8 by parameter setting (forward/reverse drive prohibition, emergency stop, external latch, origin proximity, forward/reverse torque limit, general purpose monitor input).	
	Sequence output signal	It is possible to output three types of signal form incl.: brake release, servo ready, servo alarm, positioning complete, motor rotation speed detection, torque limit detection, zero speed detection, speed coincidence detection, warning, position command status, speed limit detection, alarm output, speed command status.	
Integrated functions	USB communications	Interface	Personal computer/ Connector mini-USB
		Communications standard	Compliant with USB 2.0 standard
		Function	Parameter setting, status monitoring and tuning
	MECHATROLINK-II communications	Communications protocol	MECHATROLINK-II
		Station address	41H to 51 FH (max. number of slaves: 30)
		Transmission speed	10 Mbps
		Transmission cycle	1, 2 & 4 ms
		Data length	32 bytes
	Autotuning	Automatic motor parameter setting. One parameter rigidity setting. Inertia detection.	
	Dynamic brake (DB)	Built-in. Operates during main power OFF, servo alarm, servo OFF or overtravel.	
Regenerative processing	Internal resistor included in models from 600 W to 5 kW. Regenerative resistor externally mounted (option).		
Overtravel (OT) prevention function	DB stop, deceleration stop or coast to stop during P-OT, N-OT operation		
Encoder divider function	Optional division possible		
Protective functions	Overcurrent, overvoltage, undervoltage, overspeed, overload, encoder error, overheat...		
Analog monitor functions for supervision	Analog monitor of motor speed, speed reference, torque reference, command following error, analog input... The monitoring signals to output and their scaling can be specified with parameters. Number of channels: 2 (Output voltage: ±10V DC)		
Panel operator	Display functions	2-digit 7-segment LED display shows the drive status, alarm codes, parameters...	
	Switches	MECHATROLINK-II communications status LED indicator (COM) 2 x rotary switches for setting the MECHATROLINK-II node address	
CHARGE lamp	Lits when the main circuit power supply is turned ON.		
Safety terminal	Functions	Safety Torque OFF function to cut off the motor current and stop the motor. Output signal for failure monitoring function.	
	Conformed standards	EN ISO13849-1:2008 (PL- d, Performance Level d), IEC61800-5 -2:2007 (function STO, Safe Torque OFF), EN61508:2001 (Safety Integrity Level 2, SIL2), EN954-1:1996 (CAT3).	
External encoder feedback	Serial signal and line-driver A-B-Z encoder for full-closed control		

General specifications (for analog/pulse servo drives)

Control modes		External control	(1) position control, (2) velocity control, (3) torque control, (4) position/velocity control, (5) position/torque control, (6) velocity/torque control and (7) full-closed control.
		Internal positioning	Drive Programming: indexer functionality enabled by parameter.
Speed/torque control	Performance	Frequency characteristics	2 kHz
		Speed zero clamp	Preset velocity command can be clamped to zero by the speed zero clamp input.
		Soft start time setting	0 to 10 s (acceleration, deceleration can be set separately). S-curve acceleration/deceleration is also available.
	Speed control	Speed reference voltage	6 VDC at rated speed: set at delivery (the scale and polarity can be set by parameters)
		Torque limit	3 VDC at rated torque (torque can be limited separately in positive/negative direction).
		Preset speed control	Preset speed is selectable from 8 internal settings by digital inputs.
Torque control	Torque reference voltage	3 VDC at rated torque: set at delivery (the scale and polarity can be set by parameters).	
	Speed limit	Speed limit can be set by parameter.	
	Command pulse	Input pulse type	Sign + pulse train, 90° phase displacement 2-phase pulse (A-phase+ B-phase) or CCW/CW pulse train
Position control	Input pulse	Input pulse frequency	4 Mpps max. (200 Kpps max. at open collector).
		Command pulse scaling (Electronic Gear)	Applicable scaling ratio: 1/1000 - 1000 Any value of 1-2 ³⁰ can be set for numerator (encoder resolution) and denominator (command pulse resolution per motor revolution). The combination has to be within the range shown above.
		Input pulse type	Sign + pulse train, 90° phase displacement 2-phase pulse (A-phase+ B-phase) or CCW/CW pulse train
Full-closed control	Input pulse	Input pulse frequency	4 Mpps max. (200 Kpps max. at open collector).
		Command pulse scaling (Electronic Gear)	Applicable scaling ratio: 1/1000 - 1000 Any value of 1-2 ³⁰ can be set for numerator (encoder resolution) and denominator (command pulse resolution). The combination has to be within the range shown above.
		External encoder scaling	Applicable scaling ratio: 1/20 - 160 Any value of 1-2 ³⁰ can be set for numerator (encoder resolution) and denominator (external encoder resolution per motor revolution). The combination has to be within the range shown above.
Drive Programming	Functionality selection	Functionality enabled by parameter.	
	Supported functionality	G5 Analogue/ Pulse servo drive with firmware 1.10 or higher.	
	Software	CX-Drive version 2.30 or higher.	
	Communication	The program can be downloaded via USB communication (CX-Drive)	
	Command types	Move relative, Move absolute, Jog, Homing, Deceleration stop, Velocity update, Timer, Output signal control, Jump, Conditional branching,	
	Number of commands	Up to 32 commands (0 to 31)	
	Command execution	Strobe input to execute the selected command or to execute a complex sequence (combination of various commands).	
Command selection	Up to 5 digital inputs to select the individual commands or sequences		

I/O signal	Position signal output		A-phase, B-phase, Z-phase line driver output and Z-phase open-collector output.
	Sequence input signal	External control	- Multi-function input x 10 by parameter setting: servo ON, control mode switching, forward/reverse drive prohibition, vibration filter switching, gain switching, electronic gear switching, error counter reset, pulse prohibition, alarm reset, internal speed selection, torque limit switching, zero speed, emergency stop, inertia ratio switching, velocity/torque command sign. - Dedicated input x 1 (SEN: sensor ON, ABS data request).
		Internal positioning (Drive programming mode)	- Multi-function input x 10 by parameter setting: servo ON, forward/reverse drive prohibition, damping filter switching, gain switching, alarm reset, torque limit switching, emergency stop, immediate stop, deceleration stop input, inertia ratio switching, latch input, origin proximity input, strobe and 5 x input command selection. - Dedicated input x 1 (SEN: sensor ON, ABS data request).
	Sequence output signal	External control	- 3 x outputs signals configured by parameter settings: brake release, servo ready, servo alarm, positioning complete, motor rotation speed detection, torque limit detection, zero speed detection, speed coincidence detection, warning, position command status, speed limit detection, speed command status. - 1 output fixed to Alarm output.
Internal positioning (Drive programming enabled)		3 x outputs signals configured by parameter settings: ready, Brake, position completed, motor speed detection, torque limit status, zero speed detection, speed conformity, warning, position command status, position completed, drive programming command output and output during drive programming. - 1 output fixed to Alarm output.	
Integrated functions	USB Communications	Interface	Personal computer/ Connector mini-USB
		Communications standard	Compliant with USB 2.0 standard
		Function	Parameter setting, status monitoring and tuning
	Autotuning		Automatic motor parameter setting. One parameter rigidity setting. Inertia detection.
	Dynamic brake (DB)		Built-in. Operates during main power OFF, servo alarm, servo OFF or overtravel.
	Regenerative processing		Internal resistor included in models from 600 W to 5 kW. Regenerative resistor externally mounted (option).
	Overtravel (OT) prevention function		DB stop, deceleration stop or coast to stop during P-OT, N-OT operation
	Encoder divider function		Optional division possible
	Electronic gearing (Numerator/Denominator)		Up to 4 electronic gear numerators by combining with inputs.
	Internal speed setting function		8 speeds may be set internally
	Protective functions		Overcurrent, overvoltage, undervoltage, overspeed, overload, encoder error, overheat...
	Analog monitor functions for supervision		Analog monitor of motor speed, speed reference, torque reference, command following error, analog input... The monitoring signals to output and their scaling can be specified by parameters. Number of channels: 2 (Output voltage: ±10V DC)
	Panel operator	Display functions	6-digit 7-segment LED display shows the drive status, alarm codes, parameters...
		Panel operator keys	Used to set/monitor parameters and drive condition (5 key switches).
	CHARGE lamp		Lits when the main circuit power supply is turned ON.
	Safety terminal	Functions	Safety torque OFF function to cut off the motor current and stop the motor. Output signal for failure monitoring function.
		Conformed standards	EN ISO13849-1:2008 (PL- d, Performance Level d), IEC61800-5 -2:2007 (function STO, Safe Torque OFF), EN61508:2001 (Safety Integrity Level 2, SIL2), EN954-1:1996 (CAT3).
External encoder feedback		Serial signal and line-driver A-B-Z encoder for full-closed control	
Expansion connector		Serial bus for option board	

Servo drive part names

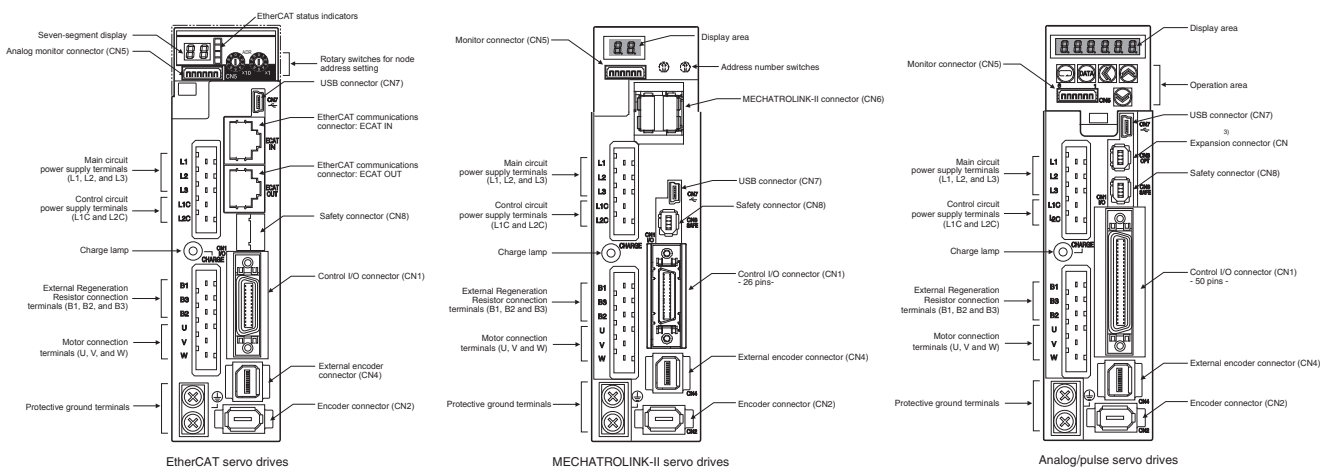

Note: the above pictures show 230 V servo drives models only. The 400 V servo drives have 24 VDC power input terminals for control circuit instead of L1C and L2C terminals.

I/O specifications

Terminals specifications (for all drives)

Symbol	Name	Function
L1	Main power supply input terminal	AC power input terminals for the main circuit Note: for single-phase servo drives connect the power supply input to L1 and L3.
L2		
L3		
L1C	Control power supply input terminal	AC power input terminals for the control circuit (for 200V single/three-phase servo drives only). DC power input terminals for the control circuit (for 400V three-phase servo drives only).
L2C		
24 V 0 V		
B1	External regeneration resistor connection terminals	Servo drives 200 V below 750 W: no internal resistor is connected. Leave B2 and B3 open. Connect an external regenerative resistor between B1 and B2. Servo drives from 600 W to 5 kW: short-circuit in B2 and B3 for internal regenerative resistor. If the internal regenerative resistor is insufficient, connect an external regenerative resistor between B1 and B2 and remove the wire between B2 and B3.
B2		
B3		
U	Servo motor connection terminals	Terminals for outputs to the servomotor.
V		
W		

I/O signals (CN1) - Input signals (for EtherCAT and MECHATROLINK-II servo drives)

Pin No.	Signal name	Function		
6	I-COM	± pole of external DC power. The power must use 12V-24V (±5%)		
5	E-STOP	Emergency stop The signal name shows the factory setting. The function can be changed by parameter setting.		
7	P-OT			
8	N-OT			
9	DEC			
10	EXT3			
11	EXT2			
12	EXT1			
13	SI-MON0			
14	BTP-I		Connecting pin for the absolute encoder backup battery. Do not connect when a battery is connected to the encoder cable (CN2 connector).	
15	BTN-I			
17	-	Terminals not used. Do not connect.		
18	-			
19	-			
20	-			
21	-			
22	-			
23	-			
24	-			
-	PCL	Forward torque limit		
	NCL		Reverse torque limit	
	SI-MON1			General-purpose monitor input 1
	SI-MON2			
Shell	FG	Shield ground. Connected to frame ground if the shield wire of the I/O signal cable is connected to the connector shell.		
16	GND	Signal ground. It is insulated with power supply (I-COM) for the control signal in the servo drive.		

I/O signals (CN1) - output signals (for EtherCAT and MECHATROLINK-II servo drives)

Pin No.	Signal name	Function												
1	BRK-OFF+	External brake release signal												
2	BRK-OFF													
25	S-RDY+	Servo ready: ON when there is no servo alarm and control/main circuit power supply is ON												
26	S-RDY-													
3	ALM+	Servo alarm: Turns OFF when an error is detected												
4	ALM-													
-	INP1	Position completed output 1												
	TGON		Speed detection											
	T_LIM			Torque limit										
	ZSP				Zero speed									
	VCMP					Speed command status								
	INP2						Position completed output 2							
	WARN1							Warning 1						
	WARN2								Warning 2					
	PCMD									Position command status				
	V_LIM										Speed limit			
	ALM-ATB											Error clear attribute (for ECT model only)		
	R-OUT1												Programmable output 1 (for ECT model only)	
	R-OUT2													Programmable output 2 (for ECT model only)

I/O signals (CN1) - Input signals (for analog/pulse servo drives)

Pin No.	Control mode	Signal name	Function	
1	Position/ Full closed loop	+24 V CW	Reference pulse input for line driver and open collector according to parameter setting. Input mode: Sign + pulse string Reverse/forward pulse (CCW/CW pulse) Two-phase pulse (90° phase differential)	
3		+CW		
4		-CW		
2		+24 V CW		
5		+CCW		
6		-CCW		
44		+CWLD		Reference pulse input for line driver only. Input mode: Reverse/forward pulse (CCW/CW pulse)
45		-CWLD		
46		+CCWLD		
47		-CCWLD		
14	Speed Torque	REF	Speed reference input: ±10 V/rated motor speed (input gain can be modified using a parameter).	
		TREF1	Torque reference input: ±10 V/rated motor torque (input gain can be modified using a parameter).	
		VLIM	Speed limit input: ±10 V/rated motor speed (input gain can be modified using a parameter).	
15	-	AGND1	Analog signal ground	
16	Torque	TREF2	Torque reference input: ±10 V/rated motor torque (input gain can be modified using a parameter).	
	Position/Speed	PCL	Forward torque limit input: ±10 V/rated motor torque (input gain can be modified using a parameter).	
18	Full closed loop	NCL	Reverse torque limit input: ±10 V/rated motor torque (input gain can be modified using a parameter).	
17	-	AGND1	Analog signal ground	
7	Common	+24 VIN	Control power supply input for sequence signals: users must provide the +24 V power supply (12 to 24 V).	
29		RUN	Servo ON: this turn ON the servo.	
26	Position/Full closed loop	DFSEL1	Vibration filter switching 1	Enables vibration filter according parameter setting.
27	Common	GSEL	Gain switching	Enables gain value according parameter setting.
28	Position/Full closed loop	GESEL1	Electronic gear switching 1	Switches the numerator fro electronic gear ratio.
	Speed	VSEL3	Internal speed selection 3	Input to select the desired speed setting during internally speed operation. The speed selecton is combining this input with VSEL1 and VSEL2 inputs.
30	Position/Full closed loop	ECRST	Error counter reset input.	Resets the position error counter.
	Speed	VSEL2	Internal speed selection 2	Input to select the desired speed setting during internally speed operation. The speed selecton is combining this input with VSEL1 and VSEL3 inputs.
31	Common	RESET	Alarm reset input.	Release the alarm status. The error counter is reset when the alarm is reset.
32	Position/ Speed/Torque	TVSEL	Control mode switching	<div style="display: flex; align-items: center; justify-content: center;"> <div style="margin-right: 10px;"> Position ↔ speed Position ↔ torque Torque ↔ speed </div> <div style="font-size: 2em;">}</div> <div style="margin-left: 10px;"> Enables control mode switching </div> </div>
33	Position	IPG	Pulse prohibition input. Digital input to inhibit the position reference pulse.	
	Speed	VSEL1	Internal speed selection 1	Input to select the desired speed setting during internally speed operation. The speed selecton is combining this input with VSEL2 and VSEL3 inputs.
8	Coomon	NOT	Reverse run prohibited	Overtravel prohibited: stops servomotor when movable part travels beyond the allowable range of motion.
9		POT	Forward run prohibited	
20	Position/ Speed/Torque	SEN	Sensor ON input. Initial data request signal when using an absolute encoder.	
13		SENGND	Sensor ON signal ground.	
42	Common	BAT (+)	Backup battery connection terminals when the absolute encoder power is interrupted. Do not connect when a absolute encoder battery cable for backup is used.	
43		BATGND (-)		
50		FG	Frame ground	
-	-	TLSEL	Torque limit switch	The function of input signals allocated to pins 8,9 and 26 to 33 can be changed with these options by parameters settings
		DFSEL2	Vibration filter switching 2	
		GESEL2	Electronic gear switching 2	
		VZERO	Zero speed	
		VSIGN	Speed command signal	
		TSIGN	Torque command signal	
		E-STOP	Emergency stop	
		JSEL	Inertia ratio switching	
	Drive Programming	EXT1	Latch input 1	
		HOME	Origin proximity input	
		H-STOP	Immediate stop input	
		S-STOP	Deceleration stop input	
		STB	Strobe	
		B-SEL1	Command selection input 1	
		B-SEL2	Command selection input 2	
		B-SEL4	Command selection input 4	
	B-SEL8	Command selection input 8		
	B-SEL16	Command selection input 16		
12	-		Terminals not used. Do not connect.	
40	-			
41	-			

I/O signals (CN1) - output signals (for analog/pulse servo drives)

Pin No.	Control mode	Signal name	Function
21	Position/ Full closed loop	+A	Encoder phase A+
22		-A	Encoder phase A-
48		+B	Encoder phase B+
49		-B	Encoder phase B-
23		+Z	Encoder phase Z+
24		-Z	Encoder phase Z-
19		Z	Encoder phase-Z output
25	ZCOM	Encoder phase-Z common	Phase Z is output for encoder signals (or external scale signals during full closing control). Open-collector output.
11	Common	BKIR	Brake release signal output
10		BKIRCOM	
35		READY	Servo ready: ON if there is not servo alarm when the control/main circuit power supply is turned ON.
34		READYCOM	
37		/ALM	Servo alarm: turns OFF when an error is detected.
36		ALMCOM	
39	Speed/torque	TGON	Motor rotation speed detection. This output turns ON when the motor rotation speed reaches the speed set in a parameter.
39	Position/ Full closed loop	INP1	Positioning complete output 1: turns ON when position error is equal to setting parameter.
38		INP1COM	
-		INP2	Position complete output 2
		P-CMD	Position command status
		ZSP	Zero speed
		WARN1	Warning 1
		WARN2	Warning 2
		ALM-ATB	Error clear attribute
		VCMP	Speed conformity output
		V-CMD	Speed command status
		V-LIMIT	Speed limit detection
		T-LIMIT	Torque limit detection
	Drive Programming	B-CTRL1	Drive Programming output 1
		B-CTRL2	Drive Programming output 2
		B-CTRL3	Drive Programming output 3
		B-BUSY	Output during Drive Programming
		HOME-CMP	Origin search complete

External encoder connector (CN4) - (for all servo drives)

Pin No.	Signal name	Function
1	E5V	External scale power supply output. Use at 5.2V +/-5% and at or below 250 mA.
2	E0V	This is connected to the control circuit ground connected to connector CN1.
3	PS	External scale signal I/O (serial signal).
4	/PS	
5	EXA	External scale signal input (Phase A, B, and Z signals). Performs the input and output of phase A, B and Z signals.
6	/EXA	
7	EXB	
8	/EXB	
9	EXZ	
10	/EXZ	
Shell	FG	Shield ground

Monitor connector (CN5) - (for all servo drives)

Pin No.	Signal name	Function
1	AM1	Analog monitor output 1. Outputs the analog signal for the monitor. Use the parameters setting to select the output to monitor. Default setting: Motor rotation speed 1 V/(1000 r/min).
2	AM2	Analog monitor output 2. Outputs the analog signal for the monitor. Use the parameters setting to select the output to monitor. Default setting: Motor rotation speed 1 V/(1000 r/min).
3	GND	Ground for analog monitors 1,2.
4	-	Terminals not used. Do not connect.
5	-	
6	-	

Safety connector (CN8) - (all servo drives)

Pin No.	Signal name	Function
1	-	Not used. Do not connect
2	-	
3	SF1-	Safety input 1 & 2. This input turns OFF the power transistor drive signals in the servo drive to cut off the current output to the motor.
4	SF1+	
5	SF2-	
6	SF2+	
7	EDM-	A monitor signal is output to detect a safety function failure.
8	EDM+	
Shell	FG	Frame ground.

Dimensions

Servo drives

R88D-KT01/02H, R88D-KN01/02H-□ (230 V, 100 - 200W)

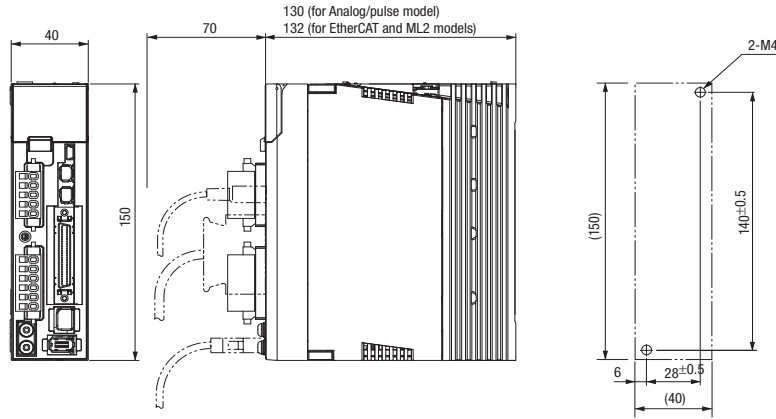

R88D-KT04H, R88D-KN04H-□ (230 V, 400 W)

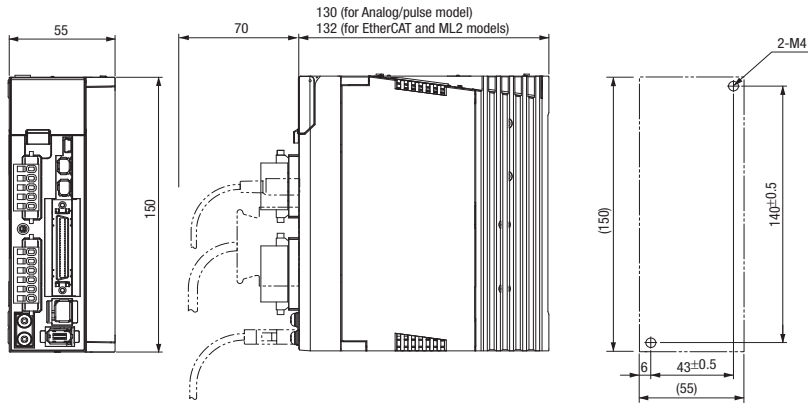

R88D-KT08H, R88D-KN08H-□ (230 V, 750 W)

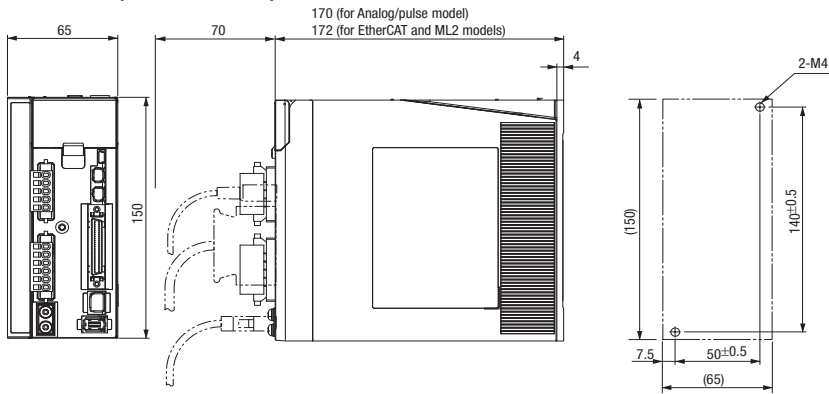

R88D-KT10/15H, R88D-KN10/15H-□ (230 V, 1 - 1.5 kW)

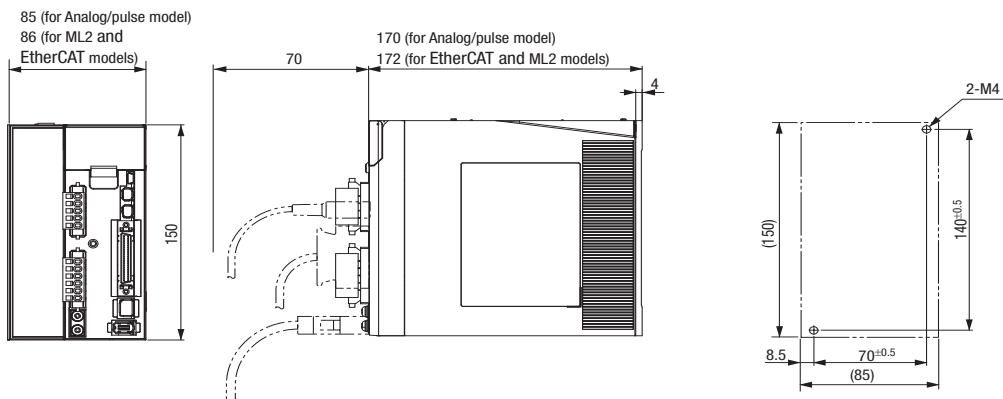

R88D-KT06/10/15F, R88D-KN06/10/15F-□ (400 V, 600 W - 1.5 kW)

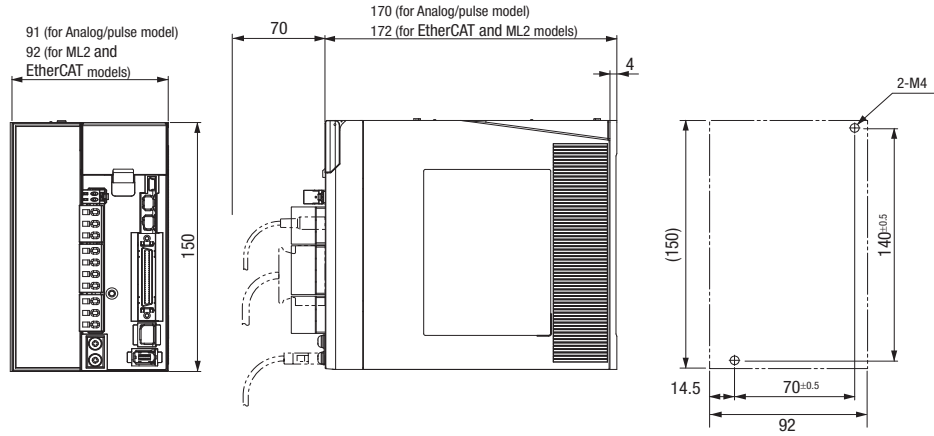

R88D-KT20F, R88D-KN20F-□ (400 V, 2 kW)

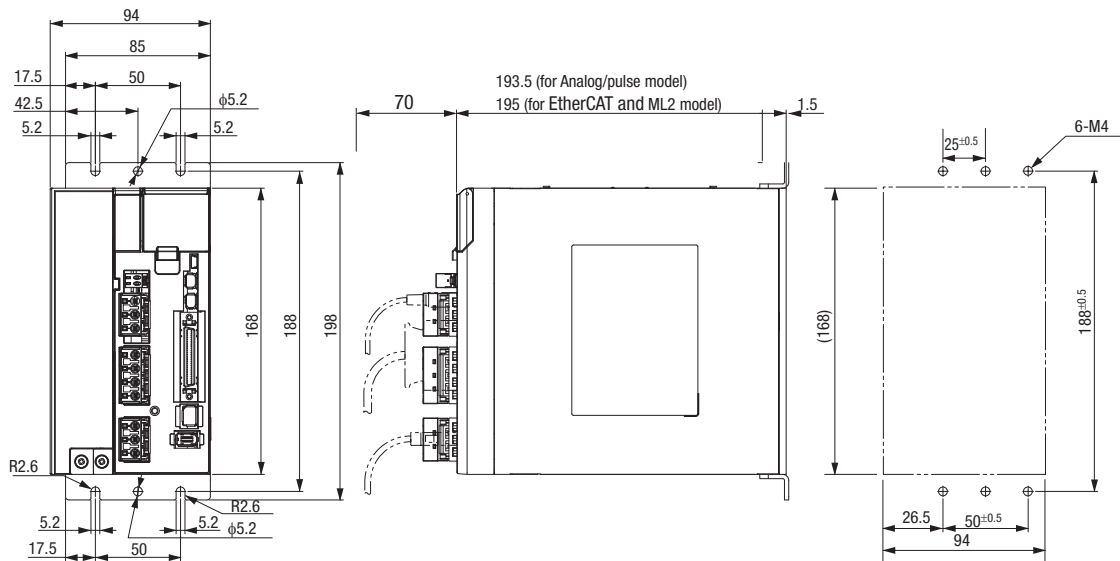

R88D-KT30/50F, R88D-KN30/50F-□ (400 V, 3 - 5 kW)

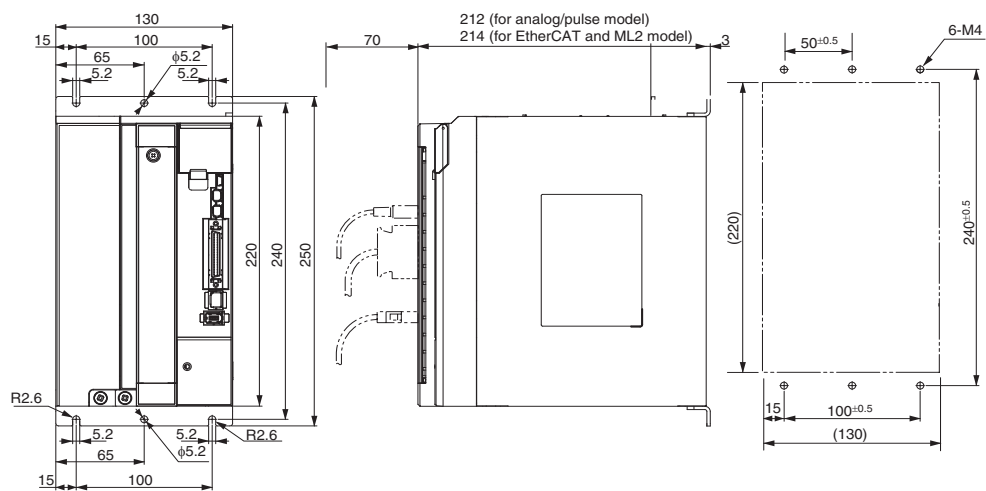

AC Servo systems

Installation

Single-phase, 230 VAC (for EtherCAT and MECHATROLINK-II servo drives)

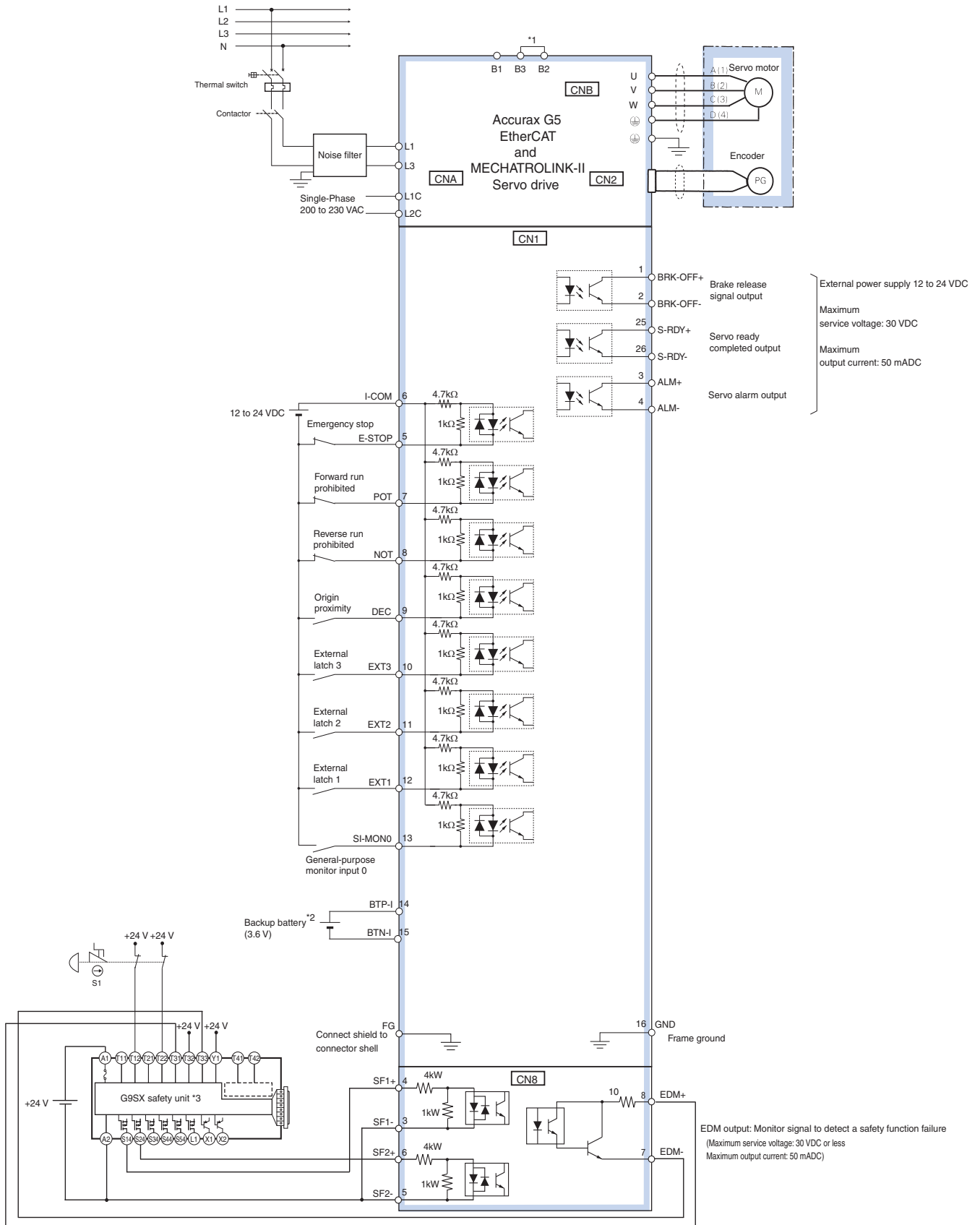

*1 For servo drives from 750 W, B2 and B3 are short-circuited. If the internal regenerative resistor is insufficient, remove the wire between B2 and B3 and connect an external regenerative resistor between B1 and B2.

*2 For use only with an absolute encoder. If a backup battery is connected to CN1 I/O connector, an encoder cable with a battery is not required.

*3 Wiring diagram example using the G9SX safety unit. If a safety unit is not used, keep the factory safety bypass connector installed in the CN8.

Note: The input function of pins 5 and 7 to 13, and output function of pins 1, 2, 25 and 26, can be changed via parameter settings.

Three-phase, 400 VAC (for EtherCAT and MECHATROLINK-II servo drives)

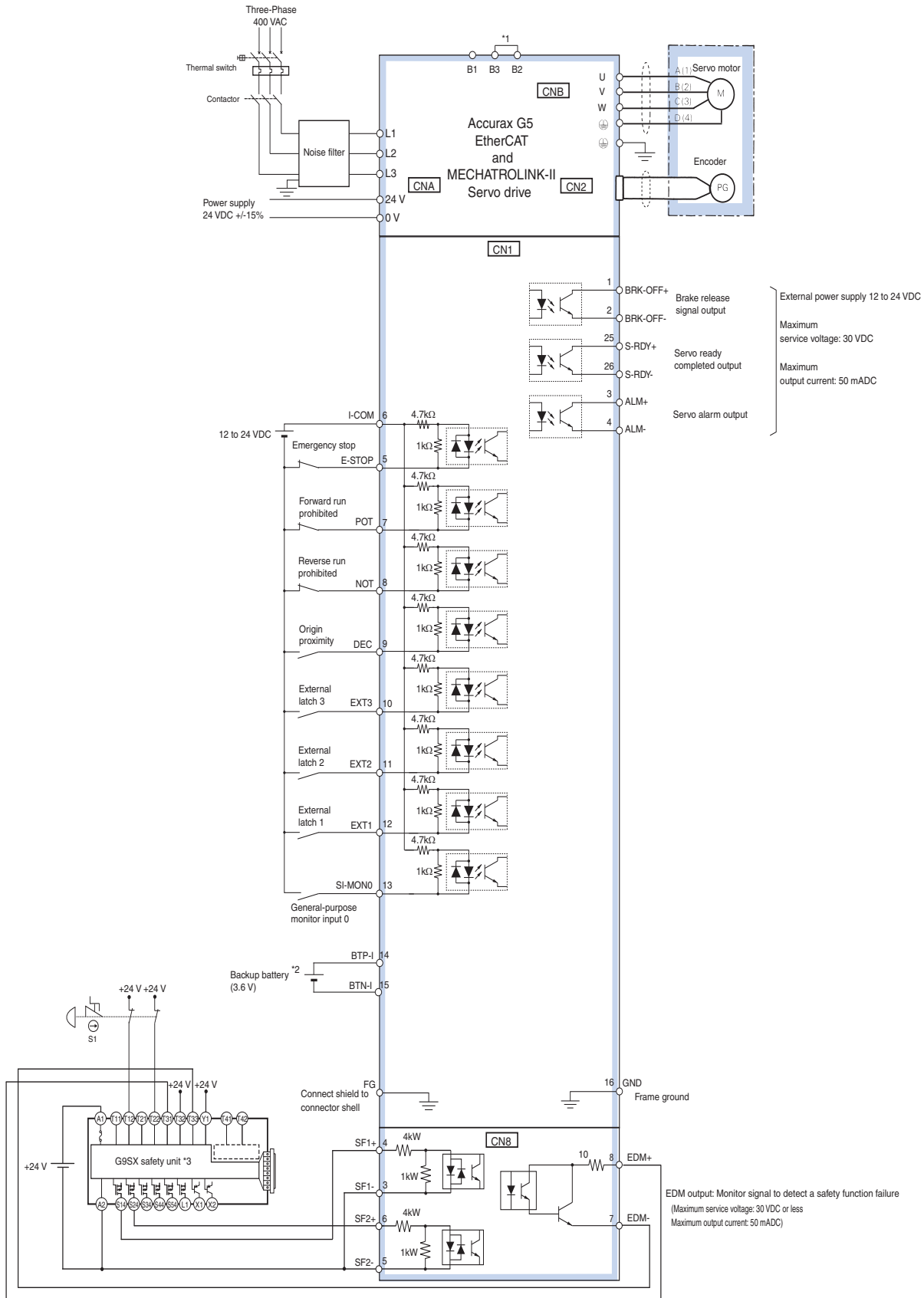

*1 Normally B2 and B3 are short-circuited. If the internal regenerative resistor is insufficient, remove the wire between B2 and B3 and connect an external regenerative resistor between B1 and B2.

*2 For use only with an absolute encoder. If a backup battery is connected to CN1 I/O connector, an encoder cable with a battery is not required.

*3 Wiring diagram example using the G9SX safety unit. If a safety unit is not used, keep the factory safety bypass connector installed in the CN8.

Note: The input function of pins 5 and 7 to 13, and output function of pins 1, 2, 25 and 26, can be changed via parameter settings.

Single-phase, 230 VAC(for analog/pulse servo drives)

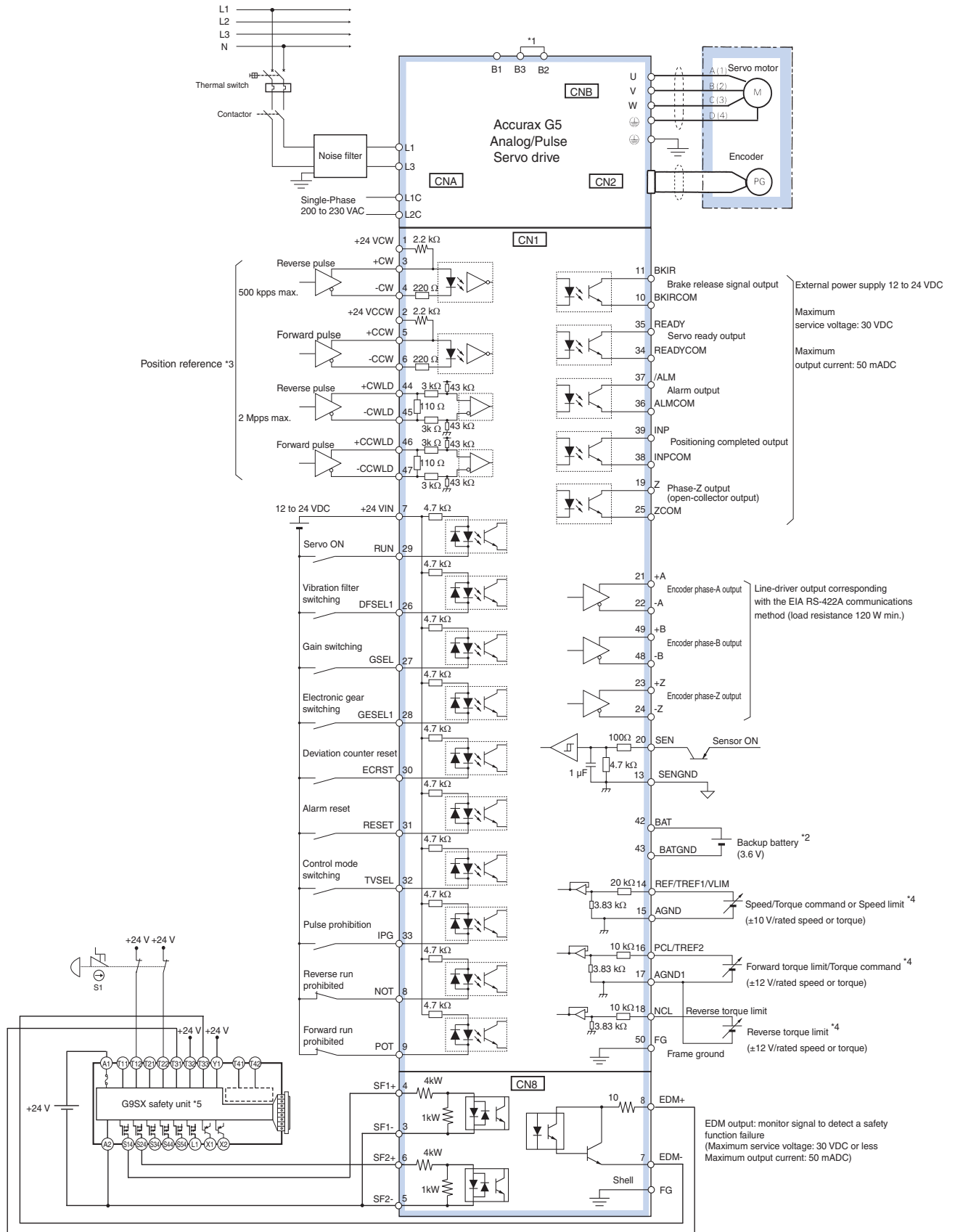

*1 For servo drives from 750 W, B2 and B3 are short-circuited. If the internal regenerative resistor is insufficient, remove the wire between B2 and B3 and connect an external regenerative resistor between B1 and B2.
 *2 For use only with an absolute encoder. If a backup battery is connected to CN1 I/O connector, an encoder cable with a battery is not required.
 *3 Only available in Position control mode.
 *4 The input function depends on control mode used (Position, speed or torque control).
 *5 Wiring diagram example using the G9SX safety unit. If a safety unit is not used, keep the factory safety bypass connector installed in the CN8.

Note: The input function of pins 8,9 and 26 to 33, and output function of pins 10, 11, 34, 35, 38 and 39, can be changed via parameter settings.

AC Servo systems

Three-phase, 400 VAC (for analog/pulse servo drives)

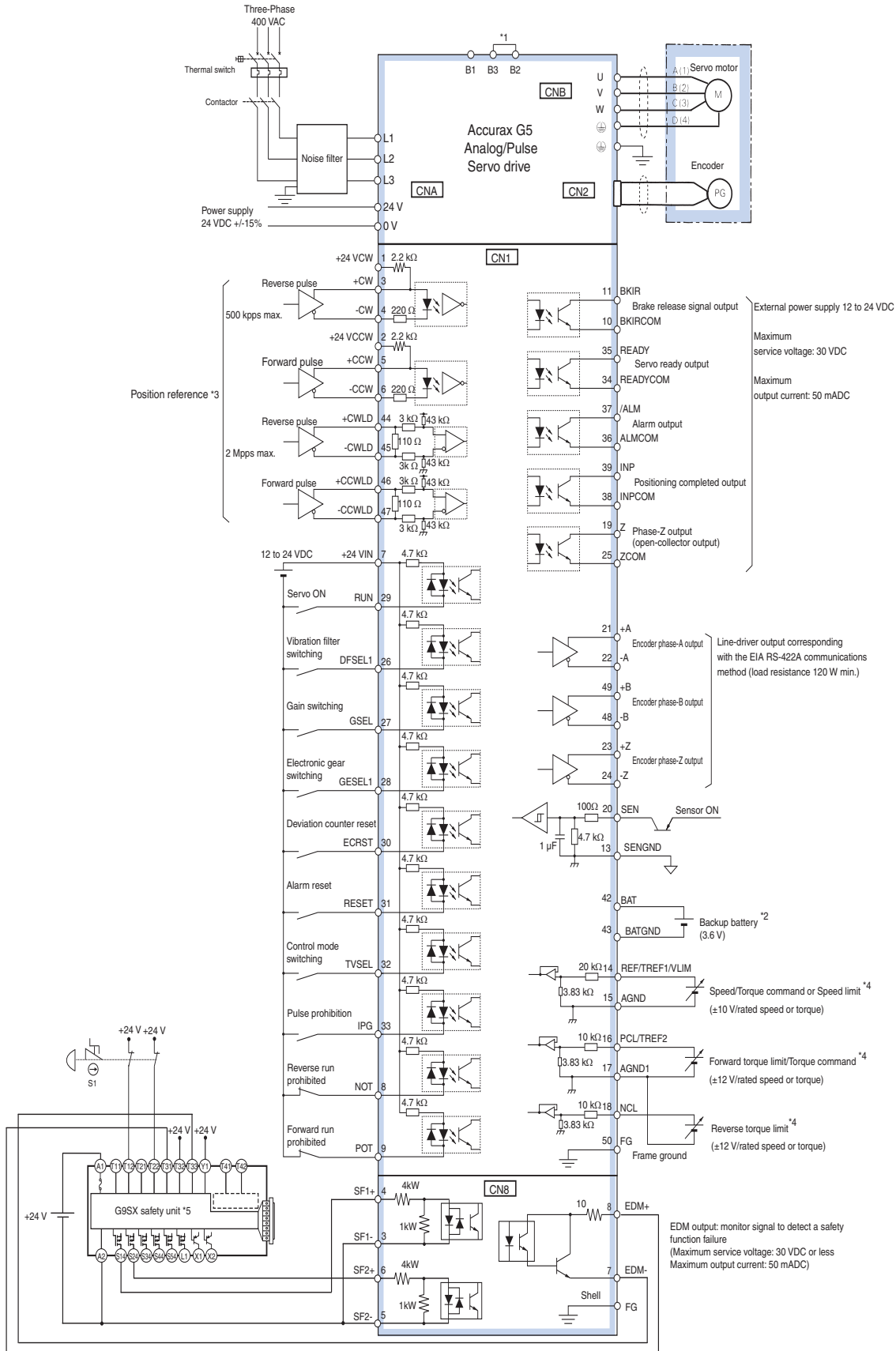

*1 Normally B2 and B3 are short-circuited. If the internal regenerative resistor is insufficient, remove the wire between B2 and B3 and connect an external regenerative resistor between B1 and B2.
 *2 For use only with an absolute encoder. If a backup battery is connected to CN1 I/O connector, an encoder cable with a battery is not required.
 *3 Only available in Position control mode.
 *4 The input function depends on control mode used (Position, speed or torque control).
 *5 Wiring diagram example using the G9SX safety unit. If a safety unit is not used, keep the factory safety bypass connector installed in the CNB.

Note: The input function of pins 8,9 and 26 to 33, and output function of pins 10, 11, 34, 35, 38 and 39, can be changed via parameter settings.

System configuration

Accurax G5 series EtherCAT reference configuration

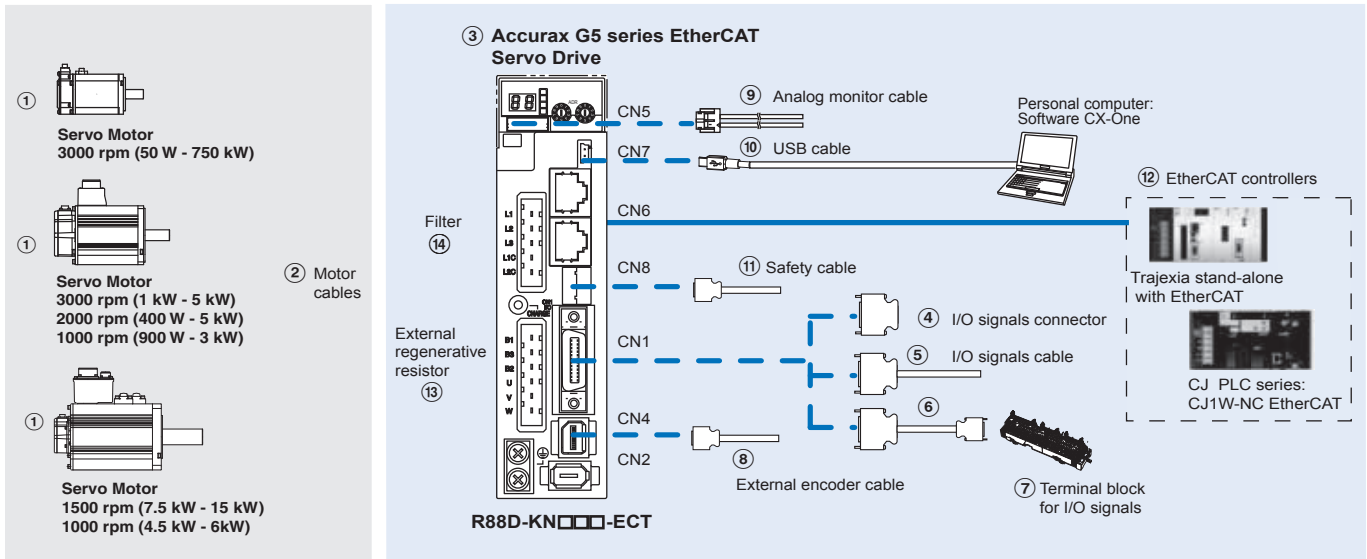

Note: The symbols ①②③④⑤... show the recommended sequence to select the components in Accurax G5 servo system

Servo motors, power & encoder cables

Note: ①② Refer to the Accurax G5 servo motor chapter for servomotor, motor cables or connectors selection

Servo drives

Symbol	Specifications	Servo drive model	① Compatible G5 series rotary servo motors
③	1 phase 230 VAC	100 W	R88D-KN01H-ECT R88M-K05030(H/T)-□ R88M-K10030(H/T)-□
		200 W	R88D-KN02H-ECT R88M-K20030(H/T)-□
		400 W	R88D-KN04H-ECT R88M-K40030(H/T)-□
		750 W	R88D-KN08H-ECT R88M-K75030(H/T)-□
		1.0 kW	R88D-KN10H-ECT R88M-K1K020(H/T)-□
		1.5 kW	R88D-KN15H-ECT R88M-K1K030(H/T)-□ R88M-K1K530(H/T)-□ R88M-K1K520(H/T)-□ R88M-K90010(H/T)-□
	3 phase 400 VAC	600 W	R88D-KN06F-ECT R88M-K40020(F/C)-□ R88M-K60020(F/C)-□
		1.0 kW	R88D-KN10F-ECT R88M-K75030(F/C)-□ R88M-K1K020(F/C)-□
		1.5 kW	R88D-KN15F-ECT R88M-K1K030(F/C)-□ R88M-K1K530(F/C)-□ R88M-K1K520(F/C)-□ R88M-K90010(F/C)-□
		2.0 kW	R88D-KN20F-ECT R88M-K2K030(F/C)-□ R88M-K2K020(F/C)-□
		3.0 kW	R88D-KN30F-ECT R88M-K3K030(F/C)-□ R88M-K3K020(F/C)-□ R88M-K2K010(F/C)-□
		5.0 kW	R88D-KN50F-ECT R88M-K4K030(F/C)-□ R88M-K5K030(F/C)-□ R88M-K4K020(F/C)-□ R88M-K5K020(F/C)-□ R88M-K4K510C-□ R88M-K3K010(F/C)-□
		7.5 kW	R88D-KN75F-ECT R88M-K6K010C-□ R88M-K7K515C-□
		15 kW	R88D-KN150F-ECT R88M-K11K015C-□ R88M-K15K015C-□

Signals cables for I/O general purpose (CN1)

Symbol	Description	Connect to	Model
④	I/O connector kit (26 pins)	For I/O general purpose	- R88A-CNW01C
⑤	I/O signals cable	For I/O general purpose	1m R88A-CPKB001S-E
			2m R88A-CPKB002S-E

Symbol	Description	Connect to	Model	
⑥	Terminal block cable	For I/O general purpose	1 m	XW2Z-100J-B34
			2 m	XW2Z-200J-B34
⑦	Terminal block (M3 screw and for pin terminals)	-	XW2B-20G4	
	Terminal block (M3.5 screw and for fork/round terminals)	-	XW2B-20G5	
	Terminal block (M3 screw and for fork/round terminals)	-	XW2D-20G6	

External encoder cable (CN4)

Symbol	Name	Model	
⑧	External encoder cable	5m	R88A-CRKM005SR-E
		10m	R88A-CRKM010SR-E
		20m	R88A-CRKM020SR-E

Analog monitor (CN5)

Symbol	Name	Model
⑨	Analog monitor cable	1m R88A-CMK001S

USB personal computer cable (CN7)

Symbol	Name	Model
⑩	USB mini-connector cable	2m AX-CUSBM002-E

Cable for safety (CN8)

Symbol	Name	Model
⑪	Safety cable	3m R88A-CSK003S-E

EtherCAT controllers

Symbol	Name	Model	
⑫	Trajexia stand-alone	Motion control unit	TJ2-MC64 (64 axes)
		EtherCAT master unit	TJ2-ECT64 (64 axes)
			TJ2-ECT16 (16 axes)
		TJ2-ECT04 (4 axes)	
	Position Controller Unit for CJ1 PLC series	CJ1W-NCF8□ (16 axes)	
		CJ1W-NC88□ (8 axes)	
		CJ1W-NC48□ (4 axes)	
		CJ1W-NC281(2 axes)	

External regenerative resistor

Symbol	Regenerative resistor unit model	Specifications
⑬	R88A-RR08050S	50 Ω, 80 W
	R88A-RR080100S	100 Ω, 80 W
	R88A-RR22047S	47 Ω, 220 W
	R88A-RR50020S	20 Ω, 500 W

Filters

Symbol	Applicable servodrive	Filter model	Rated current	Leakage current	Rated voltage
⑭	R88D-KN01H-ECT, R88D-KN02H-ECT	R88A-FIK102-RE	2.4 A	3.5 mA	250 VAC single-phase
	R88D-KN04H-ECT	R88A-FIK104-RE	4.1 A	3.5 mA	
	R88D-KN08H-ECT	R88A-FIK107-RE	6.6 A	3.5 mA	
	R88D-KN10H-ECT, R88D-KN15H-ECT	R88A-FIK114-RE	14.2 A	3.5 mA	
	R88D-KN06F-ECT, R88D-KN10F-ECT, R88D-KN15F-ECT	R88A-FIK304-RE	4 A	0.3 mA / 32 mA ¹	400 VAC three-phase
	R88D-KN20F-ECT	R88A-FIK306-RE	6 A	0.3 mA / 32 mA ¹	
	R88D-KN30F-ECT, R88D-KN50F-ECT	R88A-FIK312-RE	12.1 A	0.3 mA / 32 mA ¹	
	R88D-KN75F-ECT	R88A-FIK330-RE	-	-	
	R88D-KN150F-ECT	R88A-FIK350-RE	-	-	

1. Momentary peak leakage current for the filter at switch-on/off.

Connectors

Specifications	Model
External encoder connector (for CN4)	R88A-CNK41L
Safety I/O signal connector (for CN8)	R88A-CNK81S

Computer software

Specifications	Model
Configuration and monitoring software tool for servo drives and inverters (CX-drive version 2.10 or higher)	CX-Drive

System configuration

Accurax G5 series MECHATROLINK-II reference configuration

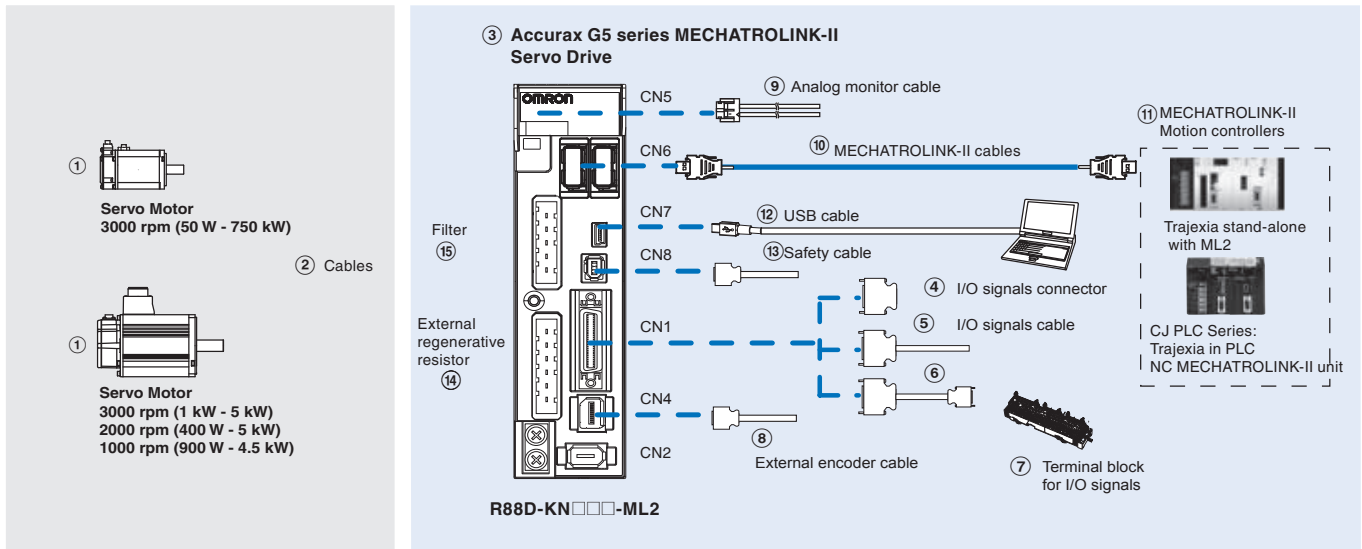

Note: The symbols ①②③④⑤... show the recommended sequence to select the components in Accurax G5 servo system

Servo motors, power & encoder cables

Note: ①② Refer to the Accurax G5 servo motor chapter for servomotor, motor cables or connectors selection

Servo drives

Symbol	Specifications	Servo drive model	① Compatible G5 series rotary servo motors
③	1 phase 230 VAC	100 W	R88D-KN01H-ML2 R88M-K05030(H/T)-□ R88M-K10030(H/T)-□
		200 W	R88D-KN02H-ML2 R88M-K20030(H/T)-□
		400 W	R88D-KN04H-ML2 R88M-K40030(H/T)-□
		750 W	R88D-KN08H-ML2 R88M-K75030(H/T)-□
		1.0 kW	R88D-KN10H-ML2 R88M-K1K020(H/T)-□
		1.5 kW	R88D-KN15H-ML2 R88M-K1K030(H/T)-□ R88M-K1K530(H/T)-□ R88M-K1K520(H/T)-□ R88M-K90010(H/T)-□
	3 phase 400 VAC	600 W	R88D-KN06F-ML2 R88M-K40020(F/C)-□ R88M-K60020(F/C)-□
		1.0 kW	R88D-KN10F-ML2 R88M-K75030(F/C)-□ R88M-K1K020(F/C)-□
		1.5 kW	R88D-KN15F-ML2 R88M-K1K030(F/C)-□ R88M-K1K530(F/C)-□ R88M-K1K520(F/C)-□ R88M-K90010(F/C)-□
		2.0 kW	R88D-KN20F-ML2 R88M-K2K030(F/C)-□ R88M-K2K020(F/C)-□
		3.0 kW	R88D-KN30F-ML2 R88M-K3K030(F/C)-□ R88M-K3K020(F/C)-□ R88M-K2K010(F/C)-□
		5.0 kW	R88D-KN50F-ML2 R88M-K4K030(F/C)-□ R88M-K5K030(F/C)-□ R88M-K4K020(F/C)-□ R88M-K5K020(F/C)-□ R88M-K4K510C-□ R88M-K3K010(F/C)-□

Control cables (for CN1)

Symbol	Description	Connect to	Model
④	I/O connector kit (26 pins)	For I/O general purpose	R88A-CNW01C
⑤	I/O signals cable		1m R88A-CPKB001S-E 2m R88A-CPKB002S-E
⑥	Terminal block cable	For I/O general purpose	1 m XW2Z-100J-B34 2 m XW2Z-200J-B34
⑦	Terminal block (M3 screw and for pin terminals)		- XW2B-20G4
	Terminal block (M3.5 screw and for fork/round terminals)		- XW2B-20G5
	Terminal block (M3 screw and for fork/round terminals)		- XW2D-20G6

External encoder cable (CN4)

Symbol	Name	Length	Model
⑧	External encoder cable	5m	R88A-CRKM005SR-E
		10m	R88A-CRKM010SR-E
		20m	R88A-CRKM020SR-E

USB personal computer cable (for CN7)

Symbol	Name	Length	Model
⑫	USB mini-connector cable	2m	AX-CUSBM002-E

Analog monitor (for CN5)

Symbol	Name	Length	Model
⑨	Analog monitor cable	1m	R88A-CMK001S

Cable for Safety Functions (for CN8)

Symbol	Description	Model
⑬	Safety connector with 3 m cable (with loose wires at one end)	R88A-CSK003S-E

MECHATROLINK-II cables (for CN6)

Symbol	Specifications	Length	Model
⑩	MECHATROLINK-II Terminator resistor	-	JEPMC-W6022-E
		MECHATROLINK-II cables	0.5 m JEPMC-W6003-A5-E 1 m JEPMC-W6003-01-E 3 m JEPMC-W6003-03-E 5 m JEPMC-W6003-05-E 10 m JEPMC-W6003-10-E 20 m JEPMC-W6003-20-E 30 m JEPMC-W6003-30-E

External regenerative resistor

Symbol	Regenerative resistor unit model	Specifications
⑭	R88A-RR08050S	50 Ω, 80 W
	R88A-RR080100S	100 Ω, 80 W
	R88A-RR22047S	47 Ω, 220 W
	R88A-RR50020S	20 Ω, 500 W

MECHATROLINK-II Motion controllers

Symbol	Name	Model		
⑪	Trajexia stand-alone	Motion control unit TJ2-MC64 (64 axes) TJ1-MC16 (16 axes) TJ1-MC04 (4 axes)		
		ML2 master unit TJ1-ML16 (16 axes) TJ1-ML04 (4 axes)		
		Trajexia-PLC motion controller	CJ1W-MCH72 (30 axes) CJ1W-MC472 (4 axes)	
			Position Controller Unit for CJ1 PLC	CJ1W-NCF71 (16 axes) CJ1W-NC471 (4 axes) CJ1W-NC271 (2 axes)
		Position Controller Unit for CS1 PLC		CS1W-NCF71 (16 axes) CS1W-NC471 (4 axes) CS1W-NC271 (2 axes)

Filters

Symbol	Applicable servodrive	Filter model	Rated current	Leakage current	Rated voltage
⑮	R88D-KN01H-ML2, R88D-KN02H-ML2	R88A-FIK102-RE	2.4 A	3.5 mA	250 VAC single-phase
	R88D-KN04H-ML2	R88A-FIK104-RE	4.1 A	3.5 mA	
	R88D-KN08H-ML2	R88A-FIK107-RE	6.6 A	3.5 mA	
	R88D-KN10H-ML2, R88D-KN15H-ML2	R88A-FIK114-RE	14.2 A	3.5 mA	
	R88D-KN06F-ML2, R88D-KN10F-ML2, R88D-KN15F-ML2	R88A-FIK304-RE	4 A	0.3 mA / 32 mA ¹	400 VAC three-phase
	R88D-KN20F-ML2	R88A-FIK306-RE	6 A	0.3 mA / 32 mA ¹	
	R88D-KN30F-ML2, R88D-KN50F-ML2	R88A-FIK312-RE	12.1 A	0.3 mA / 32 mA ¹	

1. Momentary peak leakage current for the filter at switch-on/off.

Connectors

Specifications	Model
External encoder connector (for CN4)	R88A-CNK41L
Safety I/O signal connector (for CN8)	R88A-CNK81S

Computer software

Specifications	Model
Configuration and monitoring software tool for servo drives and inverters. (CX-drive version 1.91 or higher)	CX-drive

Ordering information

Accurax G5 series Analog/pulse reference configuration

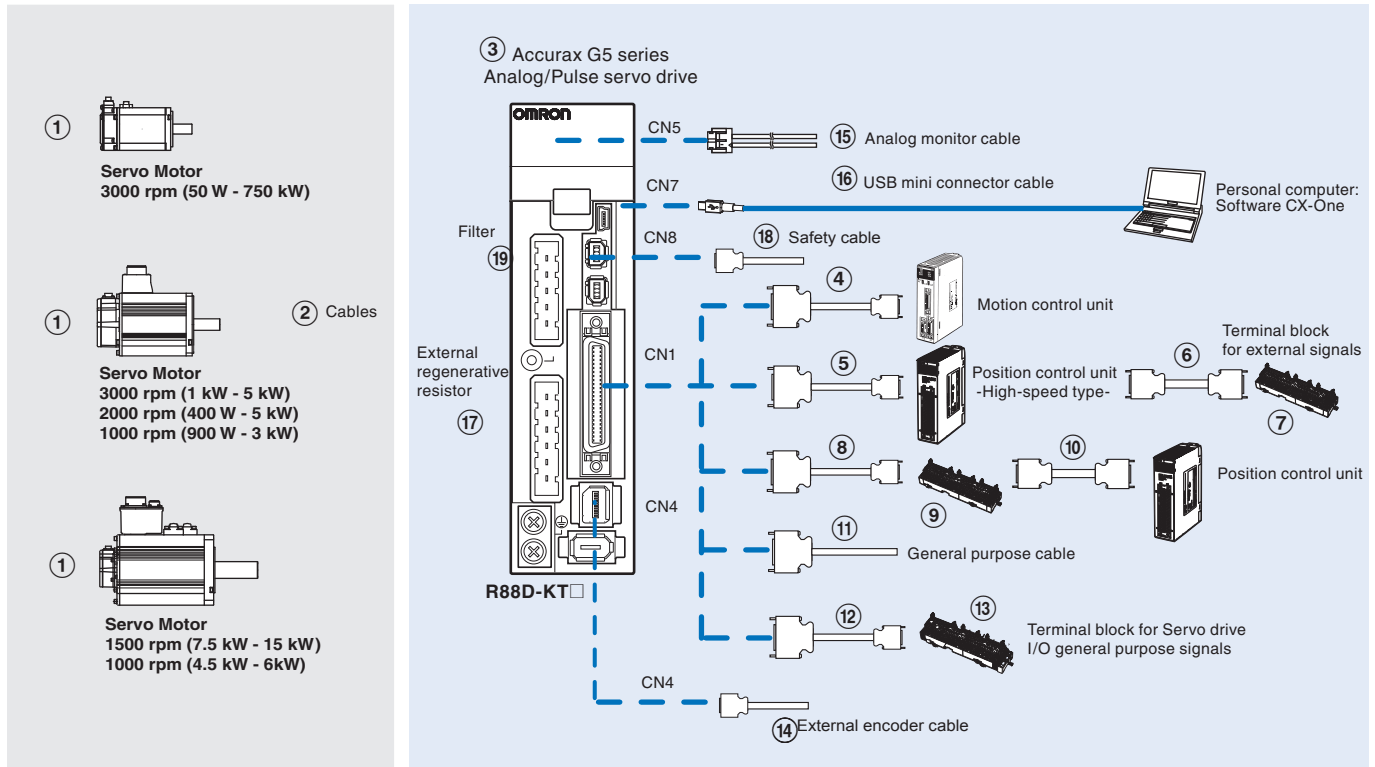

Note: The symbols ①②③④⑤... show the recommended sequence to select the components in Accurax G5 servo system

Servo motors, power & encoder cables

Note: ①② Refer to the Accurax G5 servo motor chapter for servomotor, motor cables or connectors selection

Servo drives

Symbol	Specifications	Servo drive model ¹	① Compatible Accurax G5 series rotary servo motors	
③	1 phase 230 VAC	100 W	R88D-KT01H	R88M-K05030(H/T)-□ R88M-K10030(H/T)-□
		200 W	R88D-KT02H	R88M-K20030(H/T)-□
		400 W	R88D-KT04H	R88M-K40030(H/T)-□
		750 W	R88D-KT08H	R88M-K75030(H/T)-□
		1.0 kW	R88D-KT10H	R88M-K1K020(H/T)-□
		1.5 kW	R88D-KT15H	R88M-K1K030(H/T)-□ R88M-K1K530(H/T)-□ R88M-K1K520(H/T)-□ R88M-K90010(H/T)-□
	3 phase 400 VAC	600 W	R88D-KT06F	R88M-K40020(F/C)-□ R88M-K60020(F/C)-□
		1.0 kW	R88D-KT10F	R88M-K75030(F/C)-□ R88M-K1K020(F/C)-□
		1.5 kW	R88D-KT15F	R88M-K1K030(F/C)-□ R88M-K1K530(F/C)-□ R88M-K1K520(F/C)-□ R88M-K90010(F/C)-□
		2.0 kW	R88D-KT20F	R88M-K2K030(F/C)-□ R88M-K2K020(F/C)-□
		3.0 kW	R88D-KT30F	R88M-K3K030(F/C)-□ R88M-K3K020(F/C)-□ R88M-K2K010(F/C)-□
		5.0 kW	R88D-KT50F	R88M-K4K030(F/C)-□ R88M-K5K030(F/C)-□ R88M-K4K020(F/C)-□ R88M-K5K020(F/C)-□ R88M-K4K510C-□ R88M-K3K010(F/C)-□
		7.5 kW	R88D-KT75F	R88M-K6K010C-□ R88M-K7K515C-□
		15 kW	R88D-KT150F	R88M-K11K015C-□ R88M-K15K015C-□

1. Drive Programming – embedded indexer functionality – is available in the Accurax G5 Analogue/Pulse models with firmware 1.10 or higher.

Control cables (for CN1)

Symbol	Description	Connect to		Model	
④	Control cable (1 axis)	Motion control units CS1W-MC221 CS1W-MC421	1 m	R88A-CPG001M1	
			2 m	R88A-CPG002M1	
			3 m	R88A-CPG003M1	
	Control cable (2 axis)	Motion control units CS1W-MC221 CS1W-MC421	1 m	R88A-CPG001M2	
			2 m	R88A-CPG002M2	
			3 m	R88A-CPG003M2	
⑤	Control cable (line-driver output for 1 axis)	Position control units (high-speed type) CJ1W-NC234 CJ1W-NC434	1 m	XW2Z-100J-G9	
			5 m	XW2Z-500J-G9	
			10 m	XW2Z-10MJ-G9	
	Control cable (open-collector output for 1 axis)	Position control units (high-speed type) CJ1W-NC214 CJ1W-NC414	1 m	XW2Z-100J-G13	
			3 m	XW2Z-300J-G13	
	Control cable (line-driver output for 2 axis)	Position control units (high-speed type) CJ1W-NC234 CJ1W-NC434	1 m	XW2Z-100J-G1	
			5 m	XW2Z-500J-G1	
			10 m	XW2Z-10MJ-G1	
	Control cable (open-collector output for 2 axis)	Position control units (high-speed type) CJ1W-NC214 CJ1W-NC414	1 m	XW2Z-100J-G5	
			3 m	XW2Z-300J-G5	
	⑥	Terminal block cable for external signals (for input common, forward/reverse run prohibited inputs, emergency stop input, origin proximity input and interrupt in- put)	Position control units (high-speed type) CJ1W-NC234 CJ1W-NC434 CJ1W-NC214 CJ1W-NC414	0.5 m	XW2Z-C50X
				1 m	XW2Z-100X
2 m				XW2Z-200X	
3 m				XW2Z-300X	
5 m				XW2Z-500X	
10 m				XW2Z-010X	
⑦	Terminal block for external signals (M3 screw, pin terminals)		-	XW2B-20G4	
	Terminal block for ext. signals (M3.5 screw, fork/round terminals)		-	XW2B-20G5	
	Terminal block for ext. signals (M3 screw, fork/round terminals)		-	XW2D-20G6	
⑧	Cable from servo relay unit to servo drive	CS1W-NC1□3, CJ1W-NC1□3, C200HW-NC113, CS1W-NC2□3/4□3, CJ1W-NC2□3/4□3, C200HW-NC213/413, CQM1H-PLB21 or CQM1-CPU43 CJ1M-CPU21/22/23	1 m	XW2Z-100J-B25	
			2 m	XW2Z-200J-B25	
			1 m	XW2Z-100J-B31	
			2 m	XW2Z-200J-B31	
⑨	Servo relay unit	Position control units CS1W-NC1□3, CJ1W-NC1□3 or C200HW-NC113	-	XW2B-20J6-1B (1 axis)	
			-	XW2B-40J6-2B (2 axes)	
		Position control units CS1W-NC2□3/4□3, CJ1W-NC2□3/4□3 or C200HW-NC213/413 CQM1H-PLB21 or CQM1-CPU43 CJ1M-CPU21/22/23	-	XW2B-20J6-3B (1 axis)	
			-	XW2B-20J6-8A (1 axis) XW2B-40J6-9A (2 axes)	
⑩	Position control unit connecting cable	CQM1H-PLB21 CS1W-NC113 or C200HW-NC113 CS1W-NC213/413 or C200HW-NC213/413 CS1W-NC133 CS1W-NC233/433 CJ1W-NC113 CJ1W-NC213/413 CJ1W-NC133 CJ1W-NC233/433 CJ1M-CPU21/22/23	0.5 m	XW2Z-050J-A3	
			1 m	XW2Z-100J-A3	
			0.5 m	XW2Z-050J-A6	
			1 m	XW2Z-100J-A6	
			0.5 m	XW2Z-050J-A7	
			1 m	XW2Z-100J-A7	
			0.5 m	XW2Z-050J-A10	
			1 m	XW2Z-100J-A10	
			0.5 m	XW2Z-050J-A11	
			1 m	XW2Z-100J-A11	
			0.5 m	XW2Z-050J-A14	
			1 m	XW2Z-100J-A14	
			0.5 m	XW2Z-050J-A15	
			1 m	XW2Z-100J-A15	
			0.5 m	XW2Z-050J-A18	
			1 m	XW2Z-100J-A18	
0.5 m	XW2Z-050J-A19				
1 m	XW2Z-100J-A19				
0.5 m	XW2Z-050J-A33				
1 m	XW2Z-100J-A33				
⑪	General purpose cable	For general purpose controllers	1 m	R88A-CPG001S	
			2 m	R88A-CPG002S	
⑫	Terminal block cable	For general purpose controllers	1 m	XW2Z-100J-B24	
			2 m	XW2Z-200J-B24	
⑬	Terminal block (M3 screw and for pin terminals)		-	XW2B-50G4	
	Terminal block (M3.5 screw and for fork/round terminals)		-	XW2B-50G5	
	Terminal block (M3 screw and for fork/round terminals)		-	XW2D-50G6	

External encoder cable (CN4)

Symbol	Name		Model
⑭	External encoder cable	5m	R88A-CRKM005SR-E
		10m	R88A-CRKM010SR-E
		20m	R88A-CRKM020SR-E

Analog monitor (for CN5)

Symbol	Name		Model
⑮	Analog monitor cable	1m	R88A-CMK001S

USB personal computer cable (for CN7)

Symbol	Name		Model
⑯	USB mini-connector cable	2m	AX-CUSBM002-E

Filters

Symbol	Applicable servodrive	Filter model	Rated current	Leakage current	Rated voltage
⑰	R88D-KT01H, R88D-KT02H	R88A-FIK102-RE	2.4 A	3.5 mA	250 VAC single-phase
	R88D-KT04H	R88A-FIK104-RE	4.1 A	3.5 mA	
	R88D-KT08H	R88A-FIK107-RE	6.6 A	3.5 mA	
	R88D-KT10H, R88D-KT15H	R88A-FIK114-RE	14.2 A	3.5 mA	400 VAC three-phase
	R88D-KT06F, R88D-KT10F, R88D-KT15F	R88A-FIK304-RE	4 A	0.3 mA / 32 mA ¹	
	R88D-KT20F	R88A-FIK306-RE	6 A	0.3 mA / 32 mA ¹	
	R88D-KT30F, R88D-KT50F	R88A-FIK312-RE	12.1 A	0.3 mA / 32 mA ¹	
	R88D-KT75F	R88A-FIK330-RE	–	–	
R88D-KT150F	R88A-FIK350-RE	–	–		

1. Momentary peak leakage current for the filter at switch-on/off.

External regenerative resistor

Symbol	Regenerative resistor unit model	Specifications
⑱	R88A-RR08050S	50 Ω, 80 W
	R88A-RR080100S	100 Ω, 80 W
	R88A-RR22047S	47 Ω, 220 W
	R88A-RR50020S	20 Ω, 500 W

Cable for Safety Functions (for CN8)

Symbol	Description	Model
⑲	Safety connector with 3 m cable (with loose wires at one end)	R88A-CSK003S-E

Connectors

Specifications	Model
I/O connector kit -50 pins-(for CN1)	R88A-CNU11C
External encoder connector (for CN4)	R88A-CNK41L
Safety I/O signal connector (for CN8)	R88A-CNK81S

Computer software

Specifications	Model
Configuration and monitoring software tool for servo drives and inverters. (CX-drive version 2.10 or higher)	CX-drive

ALL DIMENSIONS SHOWN ARE IN MILLIMETERS.
To convert millimeters into inches, multiply by 0.03937. To convert grams into ounces, multiply by 0.03527.

R88D-KN□□□-ECT-L, R88D-KT□□□-L

Accurax G5 linear drive

Accurate motion control in a compact size servo drive family. EtherCAT and safety built-in.

- Ironless and iron-core motor types
- EtherCAT and Analog/ Pulse servo drive models
- Safety conforming ISO13849-1 PL-d
- High-response frequency of 2 kHz
- A/B line-driver and SinCos encoder type options
- Real time auto-tuning
- Advanced tuning algorithms (Anti-vibration function, torque feedforward, disturbance observer)

Ratings

- Iron-core motors - 48 to 760 N (2000 N peak force)
- Ironless motor - 26.5 to 348 N (2100 N peak force)



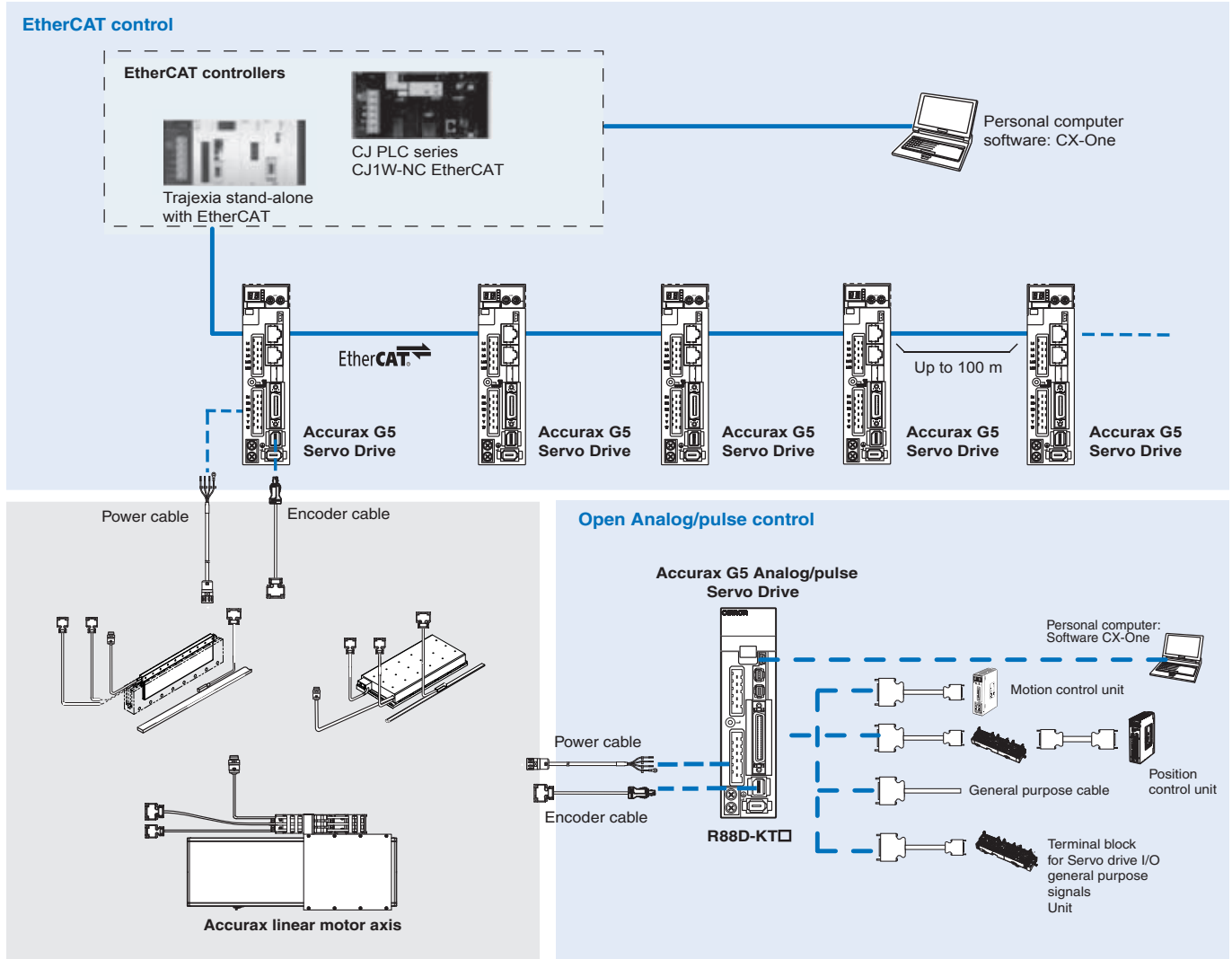

AC Servo systems

System configuration

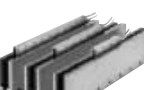

Servo motor – Servo drive combination

Linear servo motor				Accurax G5 Linear drive				
Type	Rated force	Peak force	Model	230V (EtherCAT)	400V (EtherCAT)	200V (Analog/pulse)	400V (Analog/pulse)	
Linear motor coil								
R88L-EC-FW-□ Iron-core motors  230V / 400V	48 N	105 N	Coil without connectors	R88L-EC-FW-0303-ANPC	R88D-KN02H-ECT-L	R88D-KN06F-ECT-L	R88D-KT02H-L	R88D-KT06F-L
	96 N	210 N		R88L-EC-FW-0306-ANPC	R88D-KN04H-ECT-L	R88D-KN10F-ECT-L	R88D-KT04H-L	R88D-KT10F-L
	160 N	400 N		R88L-EC-FW-0606-ANPC	R88D-KN08H-ECT-L	R88D-KN15F-ECT-L	R88D-KT08H-L	R88D-KT15F-L
	240 N	600 N		R88L-EC-FW-0609-ANPC	R88D-KN10H-ECT-L	R88D-KN20F-ECT-L	R88D-KT10H-L	R88D-KT20F-L
	320 N	800 N		R88L-EC-FW-0612-ANPC	R88D-KN15H-ECT-L	R88D-KN30F-ECT-L	R88D-KT15H-L	R88D-KT30F-L
	608 N	1600 N		R88L-EC-FW-1112-ANPC	R88D-KN15H-ECT-L	R88D-KN30F-ECT-L	R88D-KT15H-L	R88D-KT30F-L
	760 N	2000 N		R88L-EC-FW-1115-ANPC	R88D-KN15H-ECT-L	R88D-KN30F-ECT-L	R88D-KT15H-L	R88D-KT30F-L
	230V / 400V Coil with connectors	48 N	105 N	R88L-EC-FW-0303-APLC	R88D-KN02H-ECT-L	R88D-KN06F-ECT-L	R88D-KT02H-L	R88D-KT06F-L
		96 N	210 N	R88L-EC-FW-0306-APLC	R88D-KN04H-ECT-L	R88D-KN10F-ECT-L	R88D-KT04H-L	R88D-KT10F-L
		160 N	400 N	R88L-EC-FW-0606-APLC	R88D-KN08H-ECT-L	R88D-KN15F-ECT-L	R88D-KT08H-L	R88D-KT15F-L
		240 N	600 N	R88L-EC-FW-0609-APLC	R88D-KN10H-ECT-L	R88D-KN20F-ECT-L	R88D-KT10H-L	R88D-KT20F-L
		320 N	800 N	R88L-EC-FW-0612-APLC	R88D-KN15H-ECT-L	R88D-KN30F-ECT-L	R88D-KT15H-L	R88D-KT30F-L
		608 N	1600 N	R88L-EC-FW-1112-APLC	R88D-KN15H-ECT-L	R88D-KN30F-ECT-L	R88D-KT15H-L	R88D-KT30F-L
		760 N	2000 N	R88L-EC-FW-1115-APLC	R88D-KN15H-ECT-L	R88D-KN30F-ECT-L	R88D-KT15H-L	R88D-KT30F-L
R88L-EC-GW-□ Ironless motors  200V	26.5N	100 N	Coil without connectors	R88L-EC-GW-0303-ANPS	R88D-KN02H-ECT-L	-	R88D-KT02H-L	-
	53 N	200 N		R88L-EC-GW-0306-ANPS	R88D-KN08H-ECT-L	-	R88D-KT08H-L	-
	80 N	300 N		R88L-EC-GW-0309-ANPS	R88D-KN10H-ECT-L	-	R88D-KT10H-L	-
	58 N	240 N		R88L-EC-GW-0503-ANPS	R88D-KN02H-ECT-L	-	R88D-KT02H-L	-
	117 N	480 N		R88L-EC-GW-0506-ANPS	R88D-KN04H-ECT-L	-	R88D-KT04H-L	-
	175 N	720 N		R88L-EC-GW-0509-ANPS	R88D-KN08H-ECT-L	-	R88D-KT08H-L	-
	117 N	700 N		R88L-EC-GW-0703-ANPS	R88D-KN04H-ECT-L	-	R88D-KT04H-L	-
	232 N	1400 N		R88L-EC-GW-0706-ANPS	R88D-KN08H-ECT-L	-	R88D-KT08H-L	-
	348 N	2100 N		R88L-EC-GW-0709-ANPS	R88D-KN10H-ECT-L	-	R88D-KT10H-L	-
	200V Coil with connectors	26.5N	100 N	R88L-EC-GW-0303-APLS	R88D-KN02H-ECT-L	-	R88D-KT02H-L	-
		53 N	200 N	R88L-EC-GW-0306-APLS	R88D-KN08H-ECT-L	-	R88D-KT08H-L	-
		80 N	300 N	R88L-EC-GW-0309-APLS	R88D-KN10H-ECT-L	-	R88D-KT10H-L	-
		58 N	240 N	R88L-EC-GW-0503-APLS	R88D-KN02H-ECT-L	-	R88D-KT02H-L	-
		117 N	480 N	R88L-EC-GW-0506-APLS	R88D-KN04H-ECT-L	-	R88D-KT04H-L	-
		175 N	720 N	R88L-EC-GW-0509-APLS	R88D-KN08H-ECT-L	-	R88D-KT08H-L	-
		117 N	700 N	R88L-EC-GW-0703-APLS	R88D-KN04H-ECT-L	-	R88D-KT04H-L	-
		232 N	1400 N	R88L-EC-GW-0706-APLS	R88D-KN08H-ECT-L	-	R88D-KT08H-L	-
		348 N	2100 N	R88L-EC-GW-0709-APLS	R88D-KN10H-ECT-L	-	R88D-KT10H-L	-
Accurax linear motor axis								
R88L-EA-AF-□ Linear motor axis 	48 N	105 N	R88L-EA-AF-0303-□	R88D-KN02H-ECT-L	R88D-KN10F-ECT-L	R88D-KT02H-L	R88D-KT10F-L	
	96 N	210 N	R88L-EA-AF-0306-□	R88D-KN04H-ECT-L	R88D-KN10F-ECT-L	R88D-KT04H-L	R88D-KT10F-L	
	160 N	400 N	R88L-EA-AF-0606-□	R88D-KN08H-ECT-L	R88D-KN15F-ECT-L	R88D-KT08H-L	R88D-KT15F-L	
	240 N	600 N	R88L-EA-AF-0609-□	R88D-KN10H-ECT-L	R88D-KN20F-ECT-L	R88D-KT10H-L	R88D-KT20F-L	
	320 N	800 N	R88L-EA-AF-0612-□	R88D-KN15H-ECT-L	R88D-KN30F-ECT-L	R88D-KT15H-L	R88D-KT30F-L	
	608 N	1600 N	R88L-EA-AF-1112-□	R88D-KN15H-ECT-L	R88D-KN30F-ECT-L	R88D-KT15H-L	R88D-KT30F-L	
	760 N	2000 N	R88L-EA-AF-1115-□	R88D-KN15H-ECT-L	R88D-KN30F-ECT-L	R88D-KT15H-L	R88D-KT30F-L	

Note: The servo drive - motor combination has been done assuming the lower PWM frequency current. More silent operation may be obtained by selecting the higher PWM frequency in combination with one bigger servo drive size.

Type designation

Servo drive

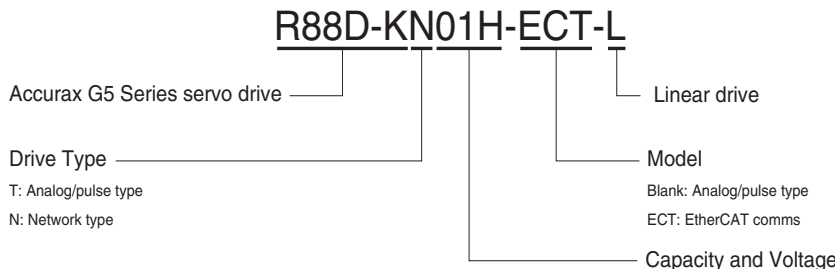

Voltage	Code	Output
230 V	01H	100 W
	02H	200 W
	04H	400 W
	08H	750 W
	10H	1 kW
	15H	1.5 kW
400 V	06F	600 W
	10F	1.0 kW
	15F	1.5 kW
	20F	2.0 kW
	30F	3.0 kW
	50F	5.0 kW
	75F	7.5 kW
	150F	15 kW

Servo drive specifications

Single-phase, 230 V

Linear servo drive type		R88D-K□	02H□□□-L	04H□□□-L	08H□□□-L	10H□□□-L	15H□□□-L					
Applicable linear servo motor	R88L-EC-	FW-0303	FW-0306	FW-0606	FW-0609	FW-0612	FW-1112					
		GW-0303	GW-0506	GW-0306	GW-0309	GW-0709	-					
		-	GW-0703	GW-0509	GW-0706	-	-					
		-	-	-	-	-	-					
Power	W	200	400	750	1000	1500						
PWM frequency	KHz	6	12	6	12	6	12					
Continuous output current	Arms	-	1.60	2.6	1.5	4	2.4	5.6	4.1	9.4	5.7	
Max. output current	Arms	-	4.89	7.8	4.5	12	7.2	16.8	12.3	28.5	17	
Input power	Main circuit	Single-phase/3-phase, 200 to 240 VAC + 10 to -15% (50/60 Hz)										
Supply	Control circuit	Single-phase, 200 to 240 VAC + 10 to -15% (50/60 Hz)										
Control method		IGBT-driven PWM method, sinusoidal drive										
Feedback		Serial encoder (incremental/absolute value)										
Conditions	Usage/storage temperature		0 to +55°C / -20 to 65°C									
	Usage/storage humidity		90% RH or less (non-condensing)									
	Altitude		1000m or less above sea level									
Vibration/shock resistance (max.)		5.88 m/s ² 10-60 Hz (Continuous operation at resonance point is not allowed) / 19.6 m/s ²										
Configuration		Base mounted										
Approx. weight	Kg	0.8		1.1		1.6				1.8		

Three-phase, 400 V

Servo drive type		R88D-K□	06F□□□-L	10F□□□-L	15F□□□-L	20F□□□-L	30F□□□-L	50F□□□-L						
Applicable linear servo motor	R88L-EC-	FW-0303	FW-0303	FW-0606	FW-0609	FW-0612	FW-1115							
		-	FW-0306	-	-	FW-1112	-							
Power	kW	0.6	1	1.5	2	3	5							
PWM frequency	KHz	6	12	6	12	6	12							
Continuous output current	Arms	1.5	1.5	2.8	1.5	4.7	2.8	5.9	4.7	9.2	5.9	16.5	9.2	
Max. output current	Arms	6.4	4.5	8.4	4.5	14.1	8.4	17.7	14.1	27.6	17.7	49.5	27.6	
Input power	Main circuit	3-phase, 380 to 480 VAC + 10 to -15% (50/60Hz)												
Supply	Control circuit	24 VDC ±15%												
Control method		IGBT-driven PWM method, sinusoidal drive												
Feedback	Serial encoder	Incremental or absolute encoder												
Conditions	Usage/storage temperature		0 to +55°C / -20 to +65°C											
	Usage/storage humidity		90% RH or less (non-condensing)											
	Altitude		1000 m or less above sea level											
Vibration/shock resistance		5.88 m/s ² 10-60 Hz (Continuous operation at resonance point is not allowed) / 19.6 m/s ²												
Configuration		Base mounted												
Approx. weight	Kg		1.9			2.7		4.7						

General specifications (for EtherCAT servo drives)

Performance		Frequency characteristics	2 kHz	
EtherCAT interface	Command input		EtherCAT commands (for sequence, motion, data setting/reference, monitor, adjustment, and other commands).	
	CiA402 Drive profile		Cyclic synchronous position mode Cyclic synchronous velocity mode Cyclic synchronous torque mode Touch probe function Torque limit function Homing mode	
I/O signal	Sequence input signal		- Multi-function input x 8 by parameter setting (forward/reverse drive prohibition, emergency stop, external latch, origin proximity, forward/reverse torque limit, general purpose monitor inputs).	
	Sequence output signal		1 x servo drive error output 2 x multi-function outputs by parameters setting (servo ready, brake release, speed limit detection, force limit detection, zero speed detection, warning output, position completion, error clear attributed, programmable output, speed detection, position command status, speed command status)	
Integrated functions	USB communications	Interface	Personal computer/ Connector mini-USB	
		Communications standard	Compliant with USB 2.0 standard	
		Function	Parameter setting, status monitoring and tuning	
	EtherCAT communications	Communications protocol	IEC 61158 Type 12, IEC 61800-7	
		Physical layer	100BASE-TX (IEEE802.3)	
		Connectors	RJ45 x 2 ECAT IN: EtherCAT input x 1 ECAT OUT: EtherCAT output x 1	
		Communications media	Category 5 or higher(cable with double, aluminium tape and braided shielding is recommended)	
	Communications distance	Distance between nodes: 100 m max.		
	LED indicators	RUN x 1 ERR x 1 L/A IN (Link/Activity IN) x 1 L/A OUT (Link/activity OUT) x 1		
	Autotuning	Automatic motor parameter setting. One parameter rigidity setting. Inertia detection.		
Dynamic brake (DB)	Built-in. Operates during main power OFF, servo alarm, servo OFF or overtravel.			
Regenerative processing	Internal resistor included in models from 600 W to 5 kW. Regenerative resistor externally mounted (option).			
Overtravel (OT) prevention function	DB stop, deceleration stop or coast to stop during P-OT, N-OT operation			
Encoder divider function	Optional division possible			
Protective functions			Overcurrent, overvoltage, undervoltage, overspeed, overload, encoder error, overheat...	
Analog monitor functions for supervision			Analog monitor of motor speed, speed reference, torque reference, command following error, analog input... The monitoring signals to output and their scaling can be specified with parameters. Number of channels: 2 (Output voltage: ±10V DC)	
Panel operator	Display functions	2 x digit 7-segment LED display shows the drive status, alarm codes, parameters...		
	Switches	2 x rotary switches for setting the node address		
CHARGE lamp			Lits when the main circuit power supply is turned ON.	
Safety terminal	Functions	Safety Torque OFF function to cut off the motor current and stop the motor. Output signal for failure monitoring function.		
	Conformed standards	EN ISO13849-1:2008 (PL- d, Performance Level d), IEC61800-5 -2:2007 (function STO, Safe Torque OFF), EN61508:2001 (Safety Integrity Level 2, SIL2), EN954-1:1996 (CAT3).		
Encoder feedback			A/B line-driver encoder and SinCos to serial conversion available. Optional hall and temperature sensors via serial converter.	

General specifications (for analog/pulse servo drives)

Control mode		6 modes selectable by parameter: (1) position control, (2) velocity control, (3) force control, (4) position/velocity control, (5) position/force control, (6) velocity/force control.		
Speed/force control	Performance	Frequency characteristics	2 kHz	
		Speed zero clamp	Preset velocity command can be clamped to zero by the speed zero clamp input.	
		Soft start time setting	0 to 1 s (acceleration, deceleration can be set separately). S-curve acceleration/deceleration is also available.	
	Input signal	Speed control	Speed reference voltage	10 VDC at rated speed: set at delivery (the scale and polarity can be set by parameters)
			Force limit	10 VDC at rated force (force can be limited separately in positive/negative direction).
		Force control	Force reference voltage	3 VDC at rated force: set at delivery (the scale and polarity can be set by parameters).
Position control	Input signal	Command pulse	Input pulse type Sign + pulse train, 90° phase displacement 2-phase pulse (A-phase+ B-phase) or CCWLD/CWLD pulse train	
		Input pulse frequency	4 Mpps max. (200 Kpps max. at open collector).	
		Command pulse scaling (Electronic Gear)	Applicable scaling ratio: 1/1000 - 1000 Any value of 1-2 ³⁰ can be set for numerator (encoder resolution) and denominator (command pulse resolution per motor revolution). The combination has to be within the range shown above.	
	Position signal output	A-phase, B.phase, Z-phase line driver output and Z-phase open-collector output.		
I/O signal	Sequence input signal		- Multi-function input x 10 by parameter setting (servo ON, control mode switching, forward/reverse drive prohibition, vibration filter switching, gain switching, electronic gear switching, error counter reset, pulse prohibition, alarm reset, internal speed selection, force limit switching, zero speed, emergency stop, mass ratio switching, velocity/force command sign).	
	Sequence output signal		It is possible to output six types of signal form incl.: brake release, servo ready, servo alarm, positioning complete, motor rotation speed detection, force limit detection, zero speed detection, speed coincidence detection, warning, position command status, speed limit detection, speed command status, alarm clear.	

Integrated functions	USB Communications	Interface	Personal computer/ Connector mini-USB	
		Communications standard	Compliant with USB 2.0 standard	
		Function	Parameter setting, status monitoring and tuning	
	Autotuning		Automatic motor parameter setting. One parameter rigidity setting. Inertia detection.	
	Dynamic brake (DB)		Built-in. Operates during main power OFF, servo alarm, servo OFF or overtravel.	
	Regenerative processing		Internal resistor included in models from 600 W to 5 kW. Regenerative resistor externally mounted (option).	
	Overtravel (OT) prevention function		DB stop, deceleration stop or coast to stop during P-OT, N-OT operation	
	Encoder divider function		Optional division possible	
	Electronic gearing (Numerator/Denominator)		Up to 4 electronic gear numerators by combining with inputs.	
	Internal speed setting function		8 speeds may be set internally	
	Protective functions		Overcurrent, overvoltage, undervoltage, overspeed, overload, encoder error, overheat...	
	Analog monitor functions for supervision		Analog monitor of motor speed, speed reference, torque reference, command following error, analog input... The monitoring signals to output and their scaling can be specified by parameters. Number of channels: 2 (Output voltage: ±10V DC)	
	Panel operator	Display functions		6-digit 7-segment LED display shows the drive status, alarm codes, parameters...
		Panel operator keys		Used to set/monitor parameters and drive condition (5 key switches).
	CHARGE lamp			Lits when the main circuit power supply is turned ON.
	Safety terminal	Functions		Safety torque OFF function to cut off the motor current and stop the motor. Output signal for failure monitoring function.
		Conformed standards		EN ISO13849-1:2008 (PL- d, Performance Level d), IEC61800-5 -2:2007 (function STO, Safe Torque OFF), EN61508:2001 (Safety Integrity Level 2, SIL2), EN954-1:1996 (CAT3).
	Encoder feedback			A/B line-driver encoder and SinCos to serial conversion available. Optional hall and temperature sensors via serial converter.
	Expansion connector			Serial bus for option board

Servo drive part names

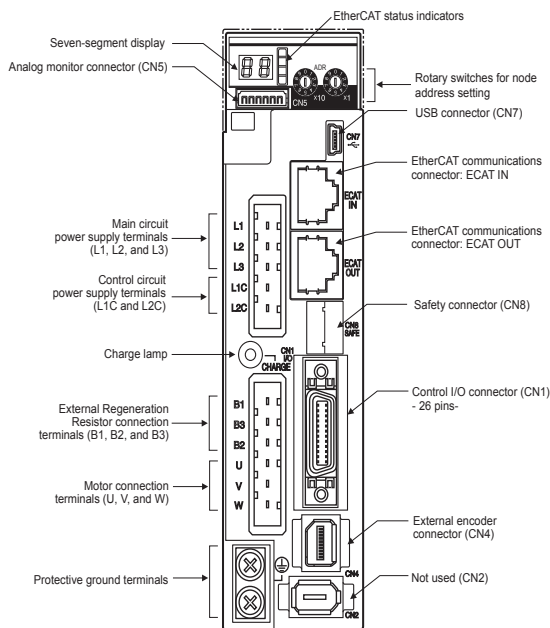

EtherCAT servo drives

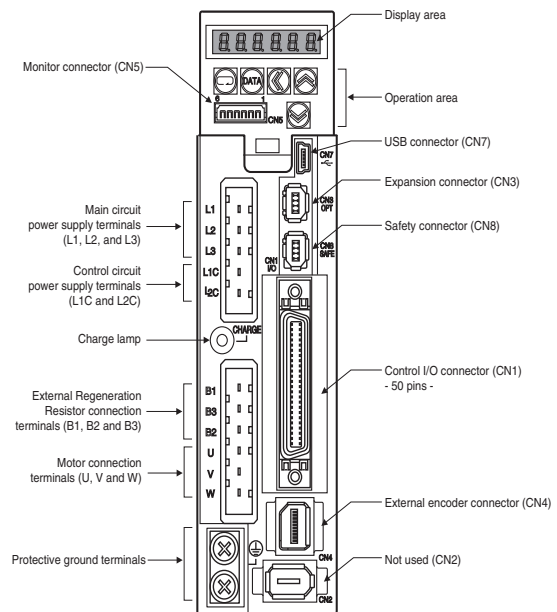

Analog/pulse servo drives

Note: the above pictures show 230 V servo drives models only. The 400 V servo drives have 24 VDC power input terminals for control circuit instead of L1C and L2C terminals.

I/O specifications

Terminals specifications (for all drives)

Symbol	Name	Function
L1	Main power supply input terminal	AC power input terminals for the main circuit Note: for single-phase servo drives connect the power supply input to L1 and L3.
L2		
L3		
L1C	Control power supply input terminal	AC power input terminals for the control circuit (for 200V single/three-phase servo drives only).
L2C		DC power input terminals for the control circuit (for 400V three-phase servo drives only).
24 V 0 V		
B1	External regeneration resistor connection terminals	Servo drives 200 V below 750 W: no internal resistor is connected. Leave B2 and B3 open.
B2		Connect an external regenerative resistor between B1 and B2.
B3		Servo drives from 600 W to 5 kW: short-circuit in B2 and B3 for internal regenerative resistor. If the internal regenerative resistor is insufficient, connect an external regenerative resistor between B1 and B2 and remove the wire between B2 and B3.
U	Servo motor connection terminals	Terminals for outputs to the servomotor.
V		
W		

I/O signals (CN1) - Input signals (for EtherCAT servo drives)

Pin No.	Signal name	Function
6	I-COM	± pole of external DC power. The power must use 12V-24V (±5%)
5	E-STOP	Emergency stop
7	P-OT	Forward run prohibited
8	N-OT	Reverse run prohibited
9	DEC	Origin proximity
10	EXT3	External latch input 3
11	EXT2	External latch input 2
12	EXT1	External latch input 1
13	SI-MON0	General purpose monitor input 0
14	-	Terminals not used. Do not connect.
15	-	
17	-	
18	-	
19	-	
20	-	
21	-	
22	-	
23	-	
24	-	
-	PCL	
-	NCL	Reverse force limit
-	SI-MON1	General-purpose monitor input 1
-	SI-MON2	General-purpose monitor input 2
Shell	FG	Shield ground. Connected to frame ground if the shield wire of the I/O signal cable is connected to the connector shell.
16	GND	Signal ground. It is insulated with power supply (I-COM) for the control signal in the servo drive.

I/O signals (CN1) - output signals (for EtherCAT servo drives)

Pin No.	Signal name	Function
1	BRK-OFF+	External brake release signal
2	BRK-OFF	
25	S-RDY+	Servo ready: ON when there is no servo alarm and control/main circuit power supply is ON
26	S-RDY-	
3	ALM+	Servo alarm: Turns OFF when an error is detected
4	ALM-	
-	INP1	Position complete output 1
-	TGON	Motor speed detection
-	F_LIMIT	Force limit detection
-	ZSP	Zero speed
-	VCMP	Speed conformity output
-	WARN1	Warning 1
-	WARN2	Warning 2
-	PCMD	Position command status
-	INP2	Position complete output 2
-	VLIMIT	Speed limit detection
-	ALM-ATB	Error clear attribute
-	VCMD	Speed command status
-	R-OUT1	Remote output 1
-	R-OUT2	Remote output 1

I/O signals (CN1) - Input signals (for analog/pulse servo drives)

Pin No.	Control mode	Signal name	Function	
1	Position	+24 VCW	Reference pulse input for line driver and open collector according to parameter setting. Input mode: Sign + pulse string Reverse/forward pulse (CCW/CW pulse) Two-phase pulse (90° phase differential)	
3		+CW		
4		-CW		
2		+24 VCCW		
5		+CCW		
6		-CCW		
44		+CWLD		Reference pulse input for line driver only.
45	-CWLD			
46	+CCWLD	Input mode: Reverse/forward pulse (CCW/CW pulse)		
47	-CCWLD			
14	Speed	REF	Speed reference input: ±10 V/rated motor speed (input gain can be modified using a parameter).	
	Force	FREF1	Force reference input: ±10 V/rated motor torque (input gain can be modified using a parameter).	
		VLIM	Speed limit input: ±10 V/rated motor speed (input gain can be modified using a parameter).	
15	-	AGND1	Analog signal ground	
16	Force	FREF2	Force reference input: ±10 V/rated motor torque (input gain can be modified using a parameter).	
	Position/Speed	PCL	Forward Force limit input: ±10 V/rated motor torque (input gain can be modified using a parameter).	
18	-	NCL	Reverse Force limit input: ±10 V/rated motor torque (input gain can be modified using a parameter).	
17	-	AGND1	Analog signal ground	
7	Common	+24 VIN	Control power supply input for sequence signals: users must provide the +24 V power supply (12 to 24 V).	
29		RUN	Servo ON: this turn ON the servo.	
26	Position	DFSEL1	Vibration filter switching 1	Enables vibration filter according parameter setting.
27	Common	GSEL	Gain switching	Enables gain value according parameter setting.
28	Position/	GESEL1	Electronic gear switching 1	Switches the numerator fro electronic gear ratio.
	Speed	VSEL3	Internal speed selection 3	Input to select the desired speed setting during internally speed operation. The speed selecton is combining this input with VSEL1 and VSEL2 inputs.
30	Position	ECRST	Error counter reset input.	Resets the position error counter.
	Speed	VSEL2	Internal speed selection 2	Input to select the desired speed setting during internally speed operation. The speed selecton is combining this input with VSEL1 and VSEL3 inputs.
31	Common	RESET	Alarm reset input.	Release the alarm status. The error counter is reset when the alarm is reset.
32	Position/ Speed/Force	TVSEL	Control mode switching	Position <--> speed Position <--> force Force <--> speed
33	Position	IPG	Pulse prohibition input. Digital input to inhibit the position reference pulse.	
	Speed	VSEL1	Internal speed selection 1	Input to select the desired speed setting during internally speed operation. The speed selecton is combining this input with VSEL2 and VSEL3 inputs.
8	Common	NOT	Reverse run prohibited	Overtravel prohibited: stops servomotor when movable part travels beyond the allowable range of motion.
9		POT	Forward run prohibited	
50	-	FG	Frame ground	
-	-	FLSEL	Force limit switch	The function of input signals allocated to pins 8,9 and 26 to 33 can be changed with these options by parameters settings
		DFSEL2	Vibration filter switching 2	
		GESEL2	Electronic gear switching 2	
		VZERO	Zero speed	
		VSIGN	Speed command signal	
		FSIGN	Force command signal	
		E-STOP	Emergency stop	
		MSEL	Mass ratio switching	
		ZSP	Zero speed	
20	-	Terminals not used. Do not connect.		
40	-			
41	-			

I/O signals (CN1) - output signals (for analog/pulse servo drives)

Pin No.	Control mode	Signal name	Function
21	Position	+A	Encoder phase A+
22		-A	Encoder phase A-
48		+B	Encoder phase B+
49		-B	Encoder phase B-
23		+Z	Encoder phase Z+
24		-Z	Encoder phase Z-
19		-Z	Encoder phase-Z output
25		ZCOM	Encoder phase-Z common
11	Common	BKIR	Brake release signal output
10		BKIRCOM	
35		READY	Servo ready: ON if there is not servo alarm when the control/main circuit power supply is turned ON.
34		READYCOM	
37		/ALM	Servo alarm: turns OFF when an error is detected.
36		ALMCOM	
39	Speed/force	TGON	Motor rotation speed detection. This output turns ON when the motor rotation speed reaches the speed set in a parameter.
38		TGONCOM	
39	Position	INP1	Positioning complete output 1: turns ON when position error is equal to setting parameter.
38		INP1COM	
40	Force limiting output	FLIM	This output turn ON while the force is limited.
41		FLIMCOM	
12	Zero speed de- tection signal	ZSP	This output turn on when the motor movements speed is equal to Zero Speed Detection (Pn435) or less
41		ZSPCOM	
-	-	INP2	Position complete output 2
		P-CMD	Position command status
		WARN1	Warning 1
		WARN2	Warning 2
		ALM-ATB	Alarm output
		V-CMD	Speed command status
		V-LIMIT	Speed limit detection
		V-CMP	Speed conformity output

The function of output signals allocated to pins 11,10, 34 to 40 can be changed with these options by parameters settings.

External encoder connector (CN4) - (for all servo drives)

Pin No.	Signal name	Function
1	E5V	External scale power supply output. Use at 5.2V +/-5% and at or below 250 mA.
2	E0V	This is connected to the control circuit ground connected to connector CN1.
3	PS	Encoder signal (serial transmission signal)
4	/PS	
5	EXA	Encoder line driver input (A-B-Z signals)
6	/EXA	
7	EXB	
8	/EXB	
9	EXZ	
10	/EXZ	
Shell	FG	Shield ground

Monitor connector (CN5) - (for all servo drives)

Pin No.	Signal name	Function
1	AM1	Analog monitor output 1. Outputs the analog signal for the monitor. Use the parameters setting to select the output to monitor. Default setting: Motor rotation speed 1 V/(500mm/s).
2	AM2	Analog monitor output 2. Outputs the analog signal for the monitor. Use the parameters setting to select the output to monitor. Default setting: Motor rotation speed 1 V/(33% of nominal force).
3	GND	Ground for analog monitors 1,2.
4	-	Terminals not used. Do not connect.
5	-	
6	-	

Safety connector (CN8) - (all servo drives)

Pin No.	Signal name	Function
1	-	Not used. Do not connect.
2	-	
3	SF1-	Safety input 1 & 2. This input turns OFF the power transistor drive signals in the servo drive to cut off the current output to the motor.
4	SF1+	
5	SF2-	
6	SF2+	
7	EDM-	A monitor signal is output to detect a safety function failure.
8	EDM+	
Shell	FG	Frame ground.

Dimensions

Servo drives

R88D-KT02H-L, R88D-KN02H-ECT-L (230 V, 200 W)

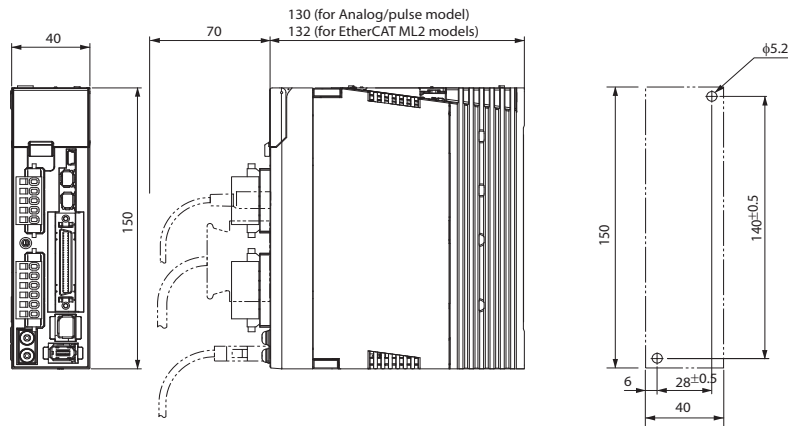

R88D-KT04H-L, R88D-KN04H-ECT-L (230 V, 400 W)

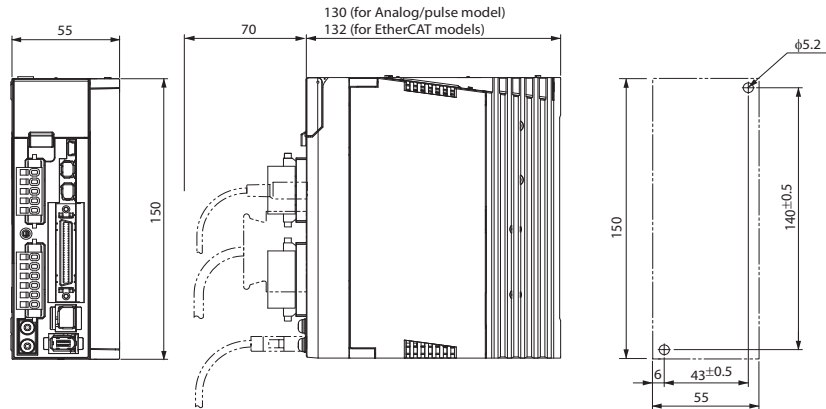

R88D-KT08H-L, R88D-KN08H-ECT-L (230 V, 800 W)

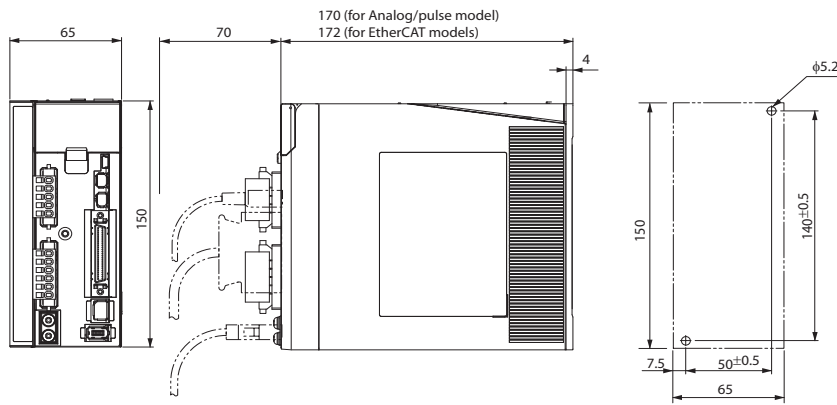

R88D-KT10/15H-L, R88D-KN10/15H-ECT-L (230 V, 1 - 1.5 kW)

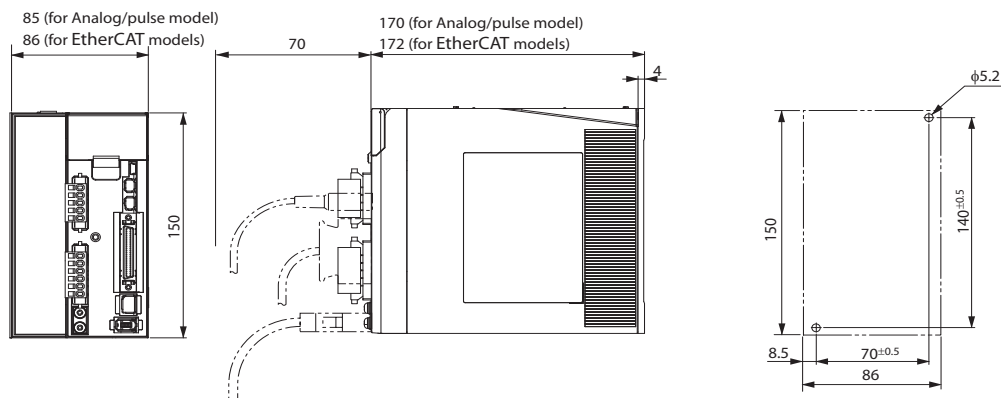

R88D-KT06/10/15F-L, R88D-KN06/10/15F-ECT-L (400 V, 600 W - 1.5 kW)

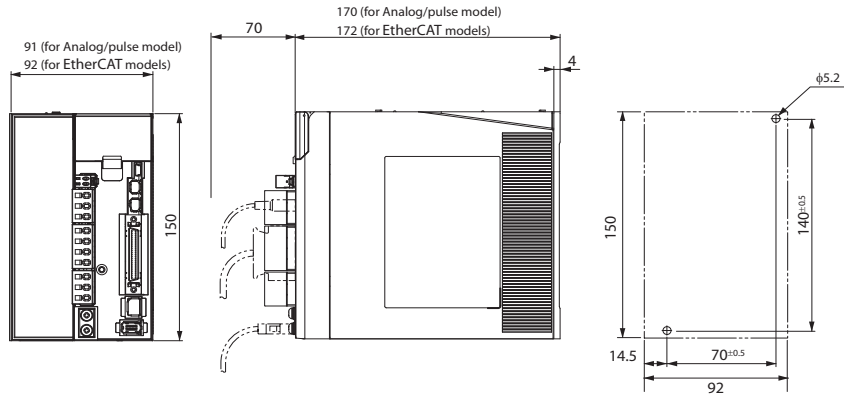

R88D-KT20F-L, R88D-KN20F-ECT-L (400 V, 2 kW)

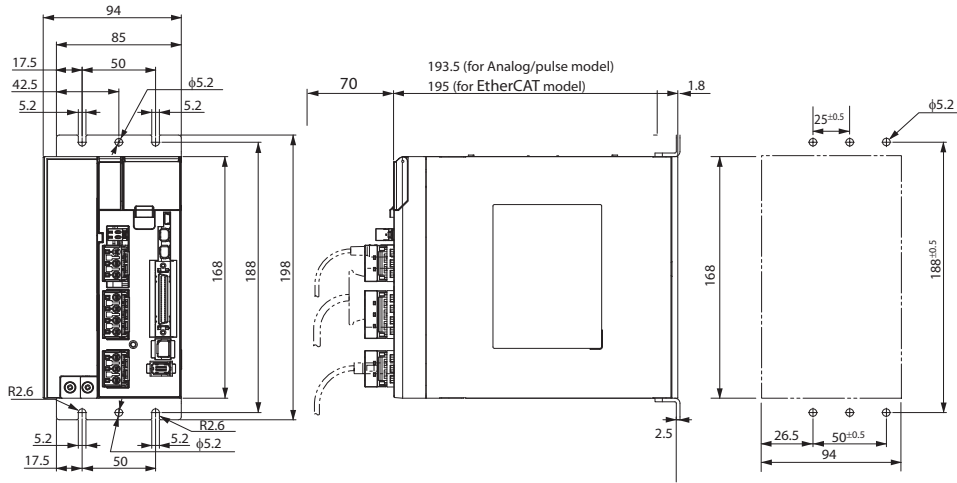

R88D-KT30/50F-L, R88D-KN30/50F-ECT-L (400 V, 3 - 5 kW)

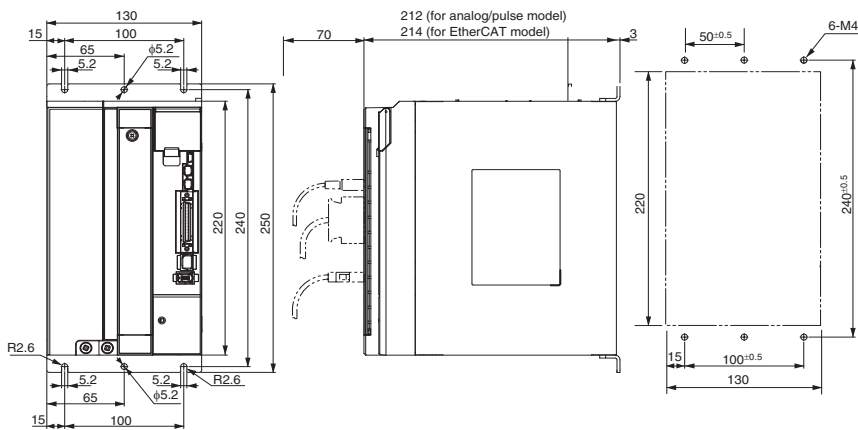

Filters

Filter model	External dimensions			Mount dimensions	
	H	W	D	M1	M2
R88A-FIK102-RE	190	42	44	180	20
R88A-FIK104-RE	190	57	30	180	30
R88A-FIK107-RE	190	64	35	180	40
R88A-FIK114-RE	190	86	35	180	60
R88A-FIK304-RE	196	92	40	186	70
R88A-FIK306-RE	238	94	40	228	70
R88A-FIK312-RE	291	130	40	278	100

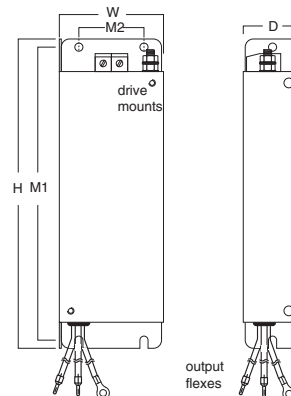

Installation

Single-phase, 230 VAC (for EtherCAT servo drives)

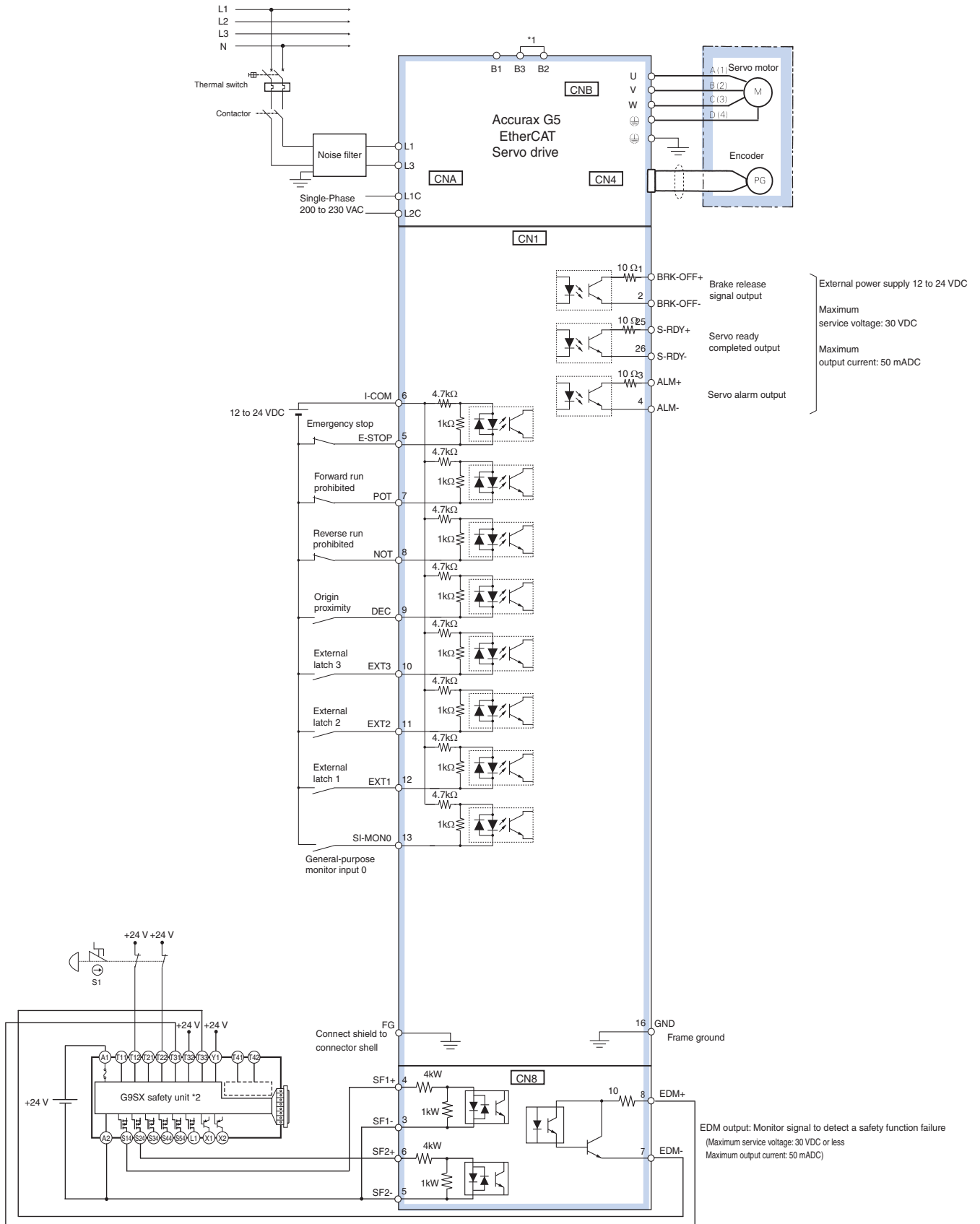

*1 For servo drives from 750 W, B2 and B3 are short-circuited. If the internal regenerative resistor is insufficient, remove the wire between B2 and B3 and connect an external regenerative resistor between B1 and B2.
 *2 Wiring diagram example using the G9SX safety unit. If a safety unit is not used, keep the factory safety bypass connector installed in the CN8.

Note: The input function of pins 5 and 7 to 13, and output function of pins 1, 2, 25 and 26, can be changed via parameter settings.

AC Servo systems

Three-phase, 400 VAC (for EtherCAT servo drives)

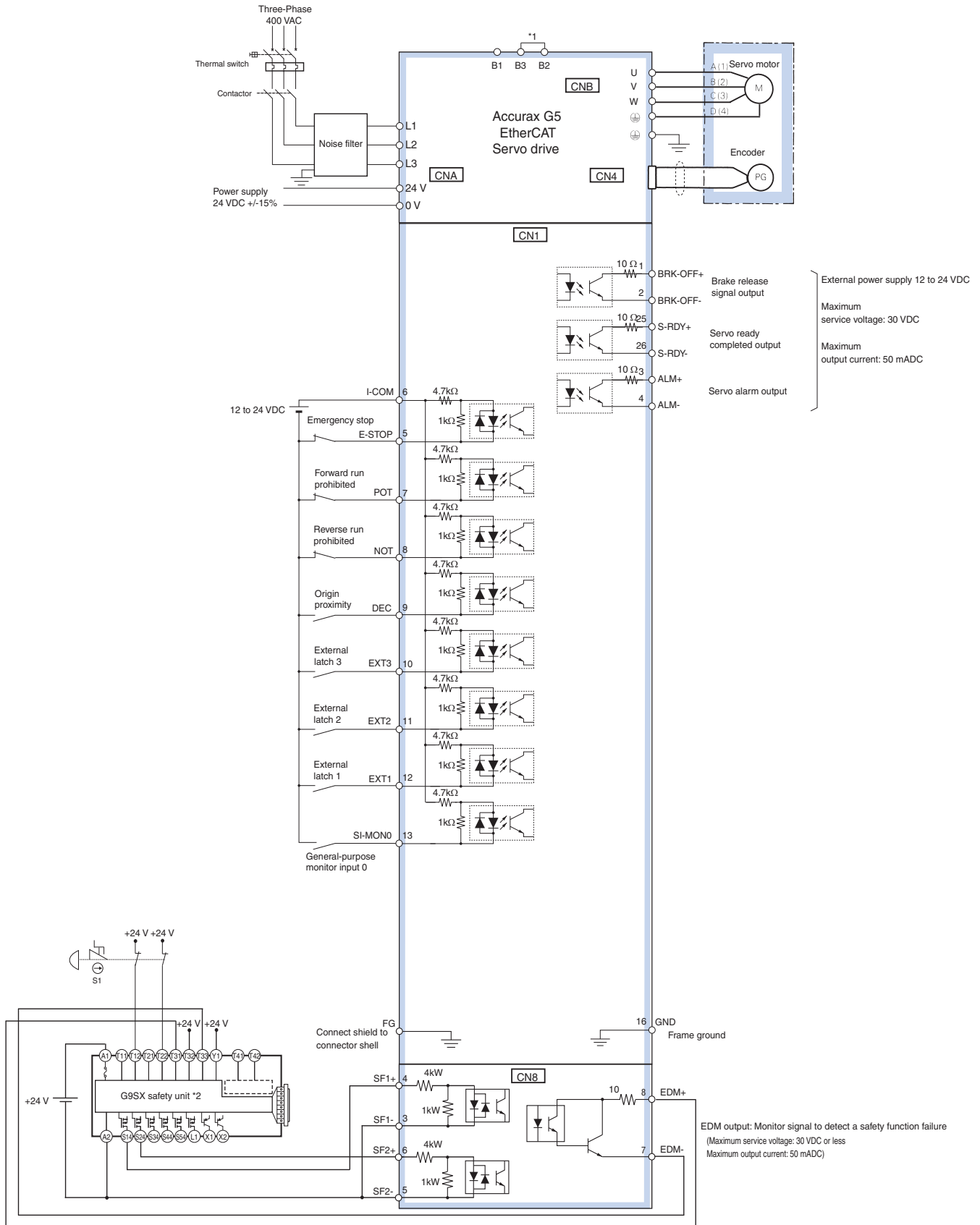

*1 Normally B2 and B3 are short-circuited. If the internal regenerative resistor is insufficient, remove the wire between B2 and B3 and connect an external regenerative resistor between B1 and B2.

*2 Wiring diagram example using the G9SX safety unit. If a safety unit is not used, keep the factory safety bypass connector installed in the CN8.

Note: The input function of pins 5 and 7 to 13, and output function of pins 1, 2, 25 and 26, can be changed via parameter settings.

Single-phase, 230 VAC(for analog/pulse servo drives)

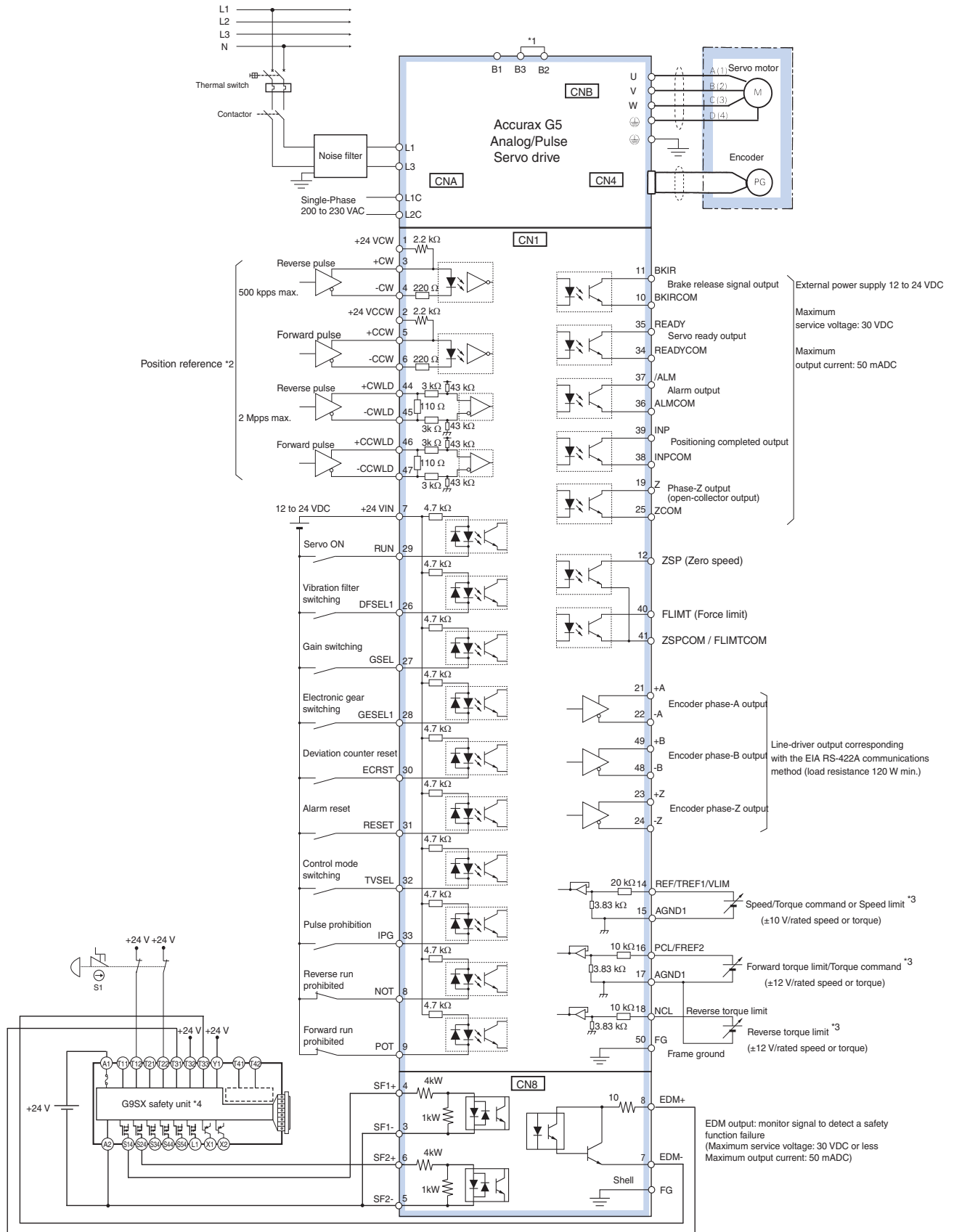

*1 For servo drives from 750 W, B2 and B3 are short-circuited. If the internal regenerative resistor is insufficient, remove the wire between B2 and B3 and connect an external regenerative resistor between B1 and B2.
 *2 Only available in Position control mode.
 *3 The input function depends on control mode used (Position, speed or torque control).
 *4 Wiring diagram example using the G9SX safety unit. If a safety unit is not used, keep the factory safety bypass connector installed in the CN8.

Note: The input function of pins 8,9 and 26 to 33, and output function of pins 10, 11, 34, 35, 38 and 39, can be changed via parameter settings.

AC Servo systems

Three-phase, 400 VAC (for analog/pulse servo drives)

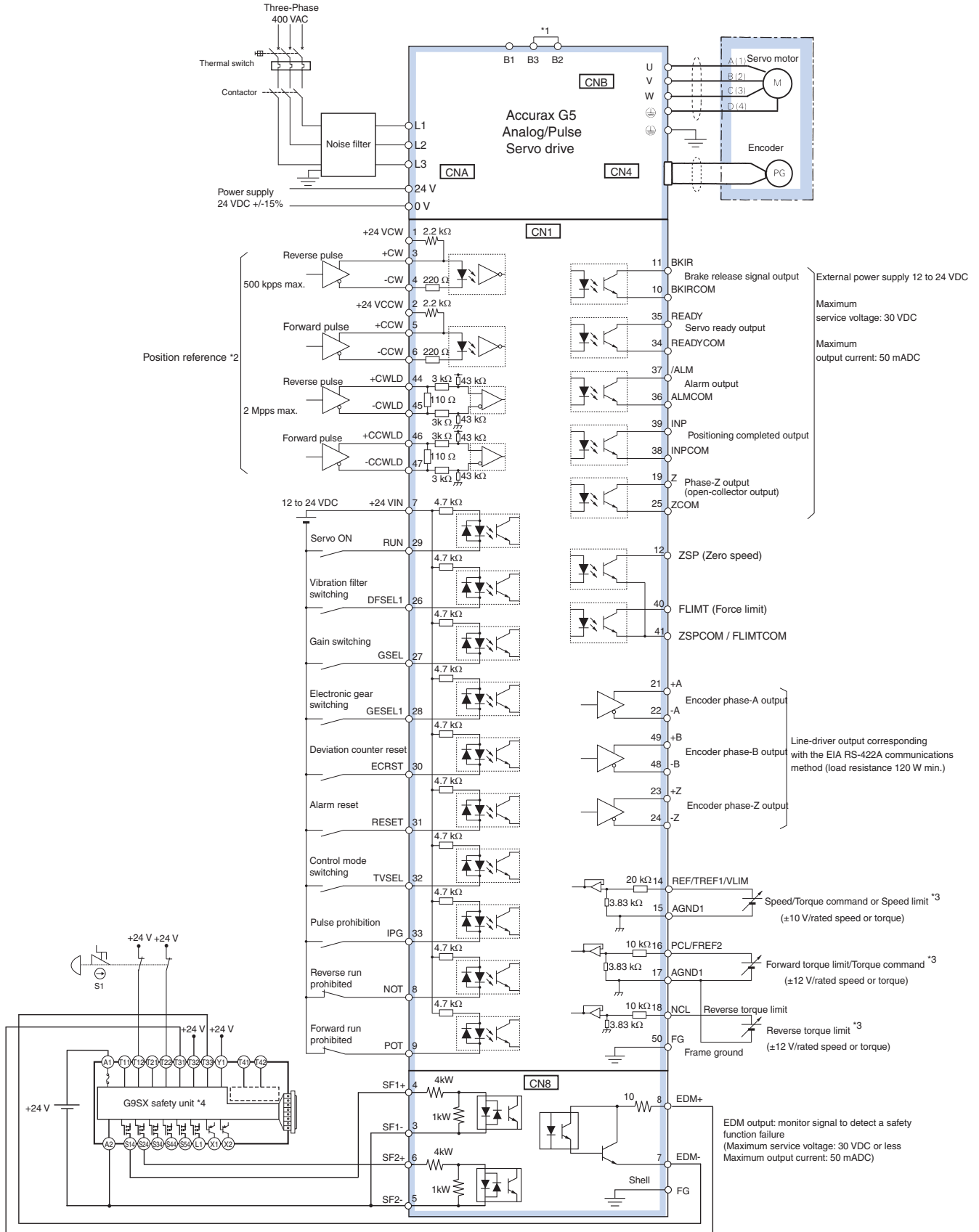

*1 Normally B2 and B3 are short-circuited. If the internal regenerative resistor is insufficient, remove the wire between B2 and B3 and connect an external regenerative resistor between B1 and B2.
 *2 Only available in Position control mode.
 *3 The input function depends on control mode used (Position, speed or torque control).
 *4 Wiring diagram example using the G9SX safety unit. If a safety unit is not used, keep the factory safety bypass connector installed in the CN8.

Note: The input function of pins 8, 9 and 26 to 33, and output function of pins 10, 11, 34, 35, 38 and 39, can be changed via parameter settings.

System configuration

Accurax G5 series EtherCAT reference configuration

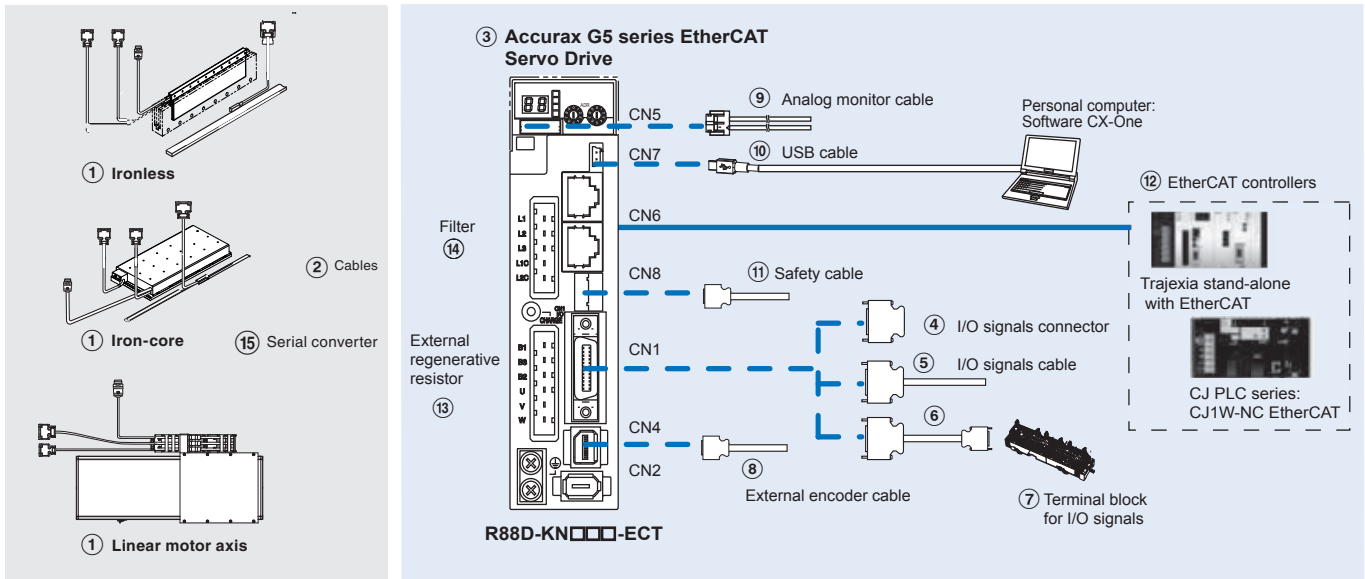

Note: The symbols ①②③④⑤... show the recommended sequence to select the components in Accurax G5 servo system

Servo motors, power & encoder cables

Note: ①②⑬ Refer to the Accurax linear motor chapter for linear motor, cables or connectors selection

Servo drives

Symbol	Specifications	Servo drive model	① Compatible Accurax G5 Linear motors		
			Iron-core motors	Ironless motors	Linear motor axis
③	1 phase 230 VAC	R88D-KN02H-ECT-L	R88L-EC-FW-0303-□	R88L-EC-GW-0303-□ R88L-EC-GW-0503-□	R88L-EA-AF-0303-□
		R88D-KN04H-ECT-L	R88L-EC-FW-0306-□	R88L-EC-GW-0506-□ R88L-EC-GW-0703-□	R88L-EA-AF-0306-□
		R88D-KN08H-ECT-L	R88L-EC-FW-0606-□	R88L-EC-GW-0306-□ R88L-EC-GW-0509-□ R88L-EC-GW-0706-□	R88L-EA-AF-0606-□
		R88D-KN10H-ECT-L	R88L-EC-FW-0609-□	R88L-EC-GW-0309-□ R88L-EC-FW-0709-□	R88L-EA-AF-0609-□
		R88D-KN15H-ECT-L	R88L-EC-FW-0612-□ R88L-EC-FW-1112-□ R88L-EC-FW-1115-□	-	R88L-EA-AF-0612-□ R88L-EA-AF-1112-□ R88L-EA-AF-1115-□
		R88D-KN06F-ECT-L	R88L-EC-FW-0303-□	-	-
	3 phase 400 VAC	R88D-KN10F-ECT-L	R88L-EC-FW-0306-□	-	R88L-EA-AF-0303-□ R88L-EA-AF-0306-□
		R88D-KN15F-ECT-L	R88L-EC-FW-0606-□	-	R88L-EA-AF-0606-□
		R88D-KN20F-ECT-L	R88L-EC-FW-0609-□	-	R88L-EA-AF-0609-□
		R88D-KN30F-ECT-L	R88L-EC-FW-0612-□	-	R88L-EA-AF-0612-□
			R88L-EC-FW-1112-□	-	R88L-EA-AF-1112-□
			R88L-EC-FW-1115-□	-	R88L-EA-AF-1115-□

Signals cables for I/O general purpose (CN1)

Symbol	Description	Connect to	Model
④	I/O connector kit (26 pins)	For I/O general purpose	R88A-CNW01C
⑤	I/O signals cable	For I/O general purpose	1m R88A-CPKB001S-E
			2m R88A-CPKB002S-E
⑥	Terminal block cable	For I/O general purpose	1 m XW2Z-100J-B34
			2 m XW2Z-200J-B34
⑦	Terminal block (M3 screw and for pin terminals)	-	XW2B-20G4
	Terminal block (M3.5 screw and for fork/round terminals)	-	XW2B-20G5
	Terminal block (M3 screw and for fork/round terminals)	-	XW2D-20G6

External encoder cable (CN4)

Symbol	Name		Model
⑧	External encoder cable	5m	R88A-CRKM005SR-E
		10m	R88A-CRKM010SR-E
		20m	R88A-CRKM020SR-E

Analog monitor (CN5)

Symbol	Name		Model
⑨	Analog monitor cable	1m	R88A-CMK001S

USB personal computer cable (CN7)

Symbol	Name		Model
⑩	USB mini-connector cable	2m	AX-CUSBM002-E

Cable for safety (CN8)

Symbol	Name		Model
⑪	Safety cable	3m	R88A-CSK003S-E

EtherCAT controllers

Symbol	Name		Model
⑫	Trajexia stand-alone motion controller	Motion control unit	TJ2-MC64 (64 axes)
		EtherCAT master unit	TJ2-ECT64 (64 axes)
			TJ2-ECT16 (16 axes)
	Position Controller Unit for CJ1 PLC series	TJ2-ECT04 (4 axes)	
		CJ1W-NCF81 (16 axes)	
		CJ1W-NC88□ (8 axes)	
		CJ1W-NC48□ (4 axes)	
		CJ1W-NC281 (2 axes)	

External regenerative resistor

Symbol	Regenerative resistor unit model	Specifications
⑬	R88A-RR08050S	50 Ω, 80 W
	R88A-RR080100S	100 Ω, 80 W
	R88A-RR22047S	47 Ω, 220 W
	R88A-RR50020S	20 Ω, 500 W

Filters

Symbol	Applicable servodrive	Filter model	Rated current	Leakage current	Rated voltage
⑭	R88D-KN02H-ECT-L	R88A-FIK102-RE	2.4 A	3.5 mA	250 VAC single-phase
	R88D-KN04H-ECT-L	R88A-FIK104-RE	4.1 A	3.5 mA	
	R88D-KN08H-ECT-L	R88A-FIK107-RE	6.6 A	3.5 mA	
	R88D-KN10H-ECT-L, R88D-KN15H-ECT-L	R88A-FIK114-RE	14.2 A	3.5 mA	400 VAC three-phase
	R88D-KN06F-ECT-L, R88D-KN10F-ECT-L, R88D-KN15F-ECT-L	R88A-FIK304-RE	4 A	0.3 mA / 32 mA ¹	
	R88D-KN20F-ECT-L	R88A-FIK306-RE	6 A	0.3 mA / 32 mA ¹	
	R88D-KN30F-ECT-L, R88D-KN50F-ECT-L	R88A-FIK312-RE	12.1 A	0.3 mA / 32 mA ¹	

1. Momentary peak leakage current for the filter at switch-on/off.

Connectors

Specifications	Model
External encoder connector (for CN4)	R88A-CNK41L
Safety I/O signal connector (for CN8)	R88A-CNK81S

Computer software

Specifications	Model
Configuration and monitoring software tool for servo drives and inverters.	CX-Drive

Ordering information

Accurax G5 series Analog/pulse reference configuration

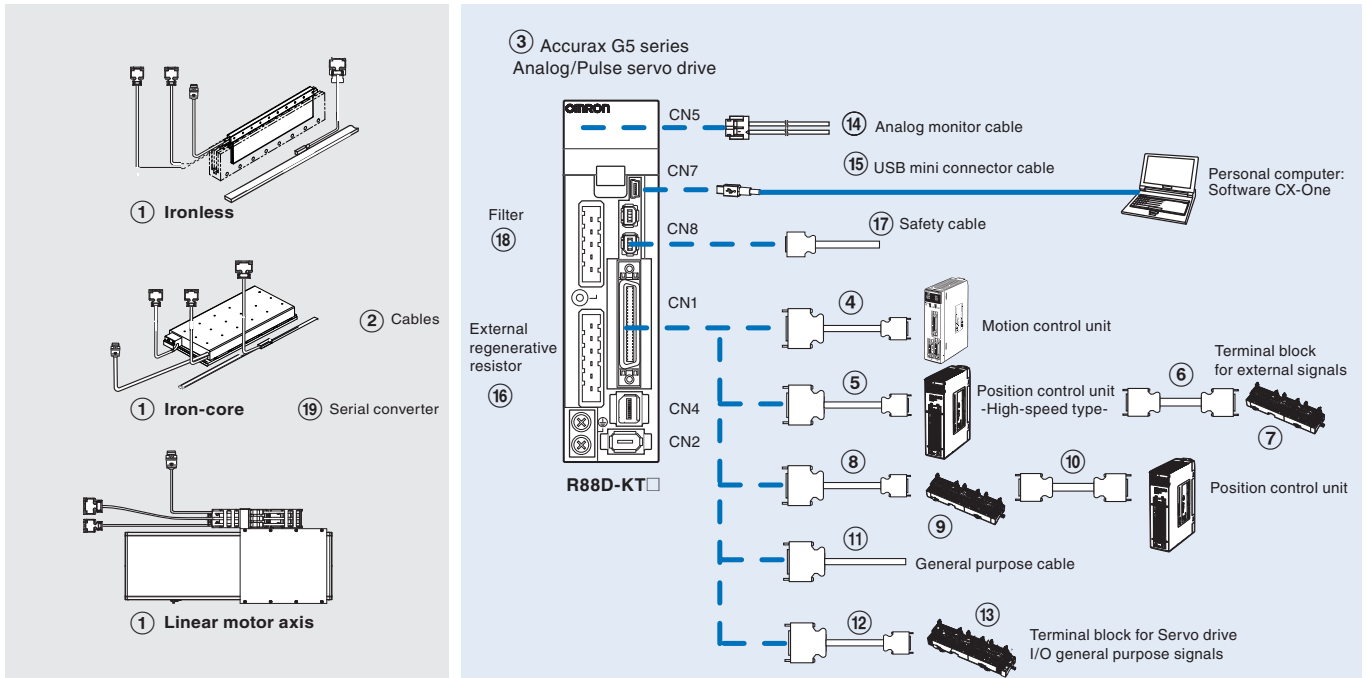

Note: The symbols ①②③④⑤... show the recommended sequence to select the components in Accurax G5 servo system

Servo motors, power & encoder cables

Note: ①②⑩ Refer to the Accurax G5 linear motor chapter for linear motor, cables or connectors selection

Servo drives

Symbol	Specifications	Servo drive model	① Compatible Accurax G5 Linear motors		
			Iron-core motors	Ironless motors	Linear motor axis
③	1 phase 230 VAC	R88D-KT02H-L	R88L-EC-FW-0303-□	R88L-EC-GW-0303-□ R88L-EC-GW-0503-□	R88L-EA-AF-0303-□
		R88D-KT04H-L	R88L-EC-FW-0306-□	R88L-EC-GW-0506-□ R88L-EC-GW-0703-□	R88L-EA-AF-0306-□
		R88D-KT08H-L	R88L-EC-FW-0606-□	R88L-EC-GW-0306-□ R88L-EC-GW-0509-□ R88L-EC-GW-0706-□	R88L-EA-AF-0606-□
		R88D-KT10H-L	R88L-EC-FW-0609-□	R88L-EC-GW-0309-□ R88L-EC-FW-0709-□	R88L-EA-AF-0609-□
		R88D-KT15H-L	R88L-EC-FW-0612-□	-	R88L-EA-AF-0612-□
			R88L-EC-FW-1112-□ R88L-EC-FW-1115-□	-	R88L-EA-AF-1112-□ R88L-EA-AF-1115-□
	3 phase 400 VAC	R88D-KT06F-L	R88L-EC-FW-0303-□	-	-
		R88D-KT10F-L	R88L-EC-FW-0306-□	-	R88L-EA-AF-0303-□ R88L-EA-AF-0306-□
		R88D-KT15F-L	R88L-EC-FW-0606-□	-	R88L-EA-AF-0606-□
		R88D-KT20F-L	R88L-EC-FW-0609-□	-	R88L-EA-AF-0609-□
		R88D-KT30F-L	R88L-EC-FW-0612-□	-	R88L-EA-AF-0612-□
			R88L-EC-FW-1112-□	-	R88L-EA-AF-1112-□
R88L-EC-FW-1115-□	-		R88L-EA-AF-1115-□		

Control cables (CN1)

Symbol	Description	Connect to		Model	
④	Control cable (1 axis)	Motion control units CS1W-MC221 CS1W-MC421	1 m	R88A-CPG001M1	
			2 m	R88A-CPG002M1	
			3 m	R88A-CPG003M1	
	Control cable (2 axis)	Motion control units CS1W-MC221-V1 CS1W-MC421-V1	1 m	R88A-CPG001M2	
			2 m	R88A-CPG002M2	
			3 m	R88A-CPG003M2	
⑤	Control cable (line-driver output for 1 axis)	Position control units (high-speed type) CJ1W-NC234 CJ1W-NC434	1 m	XW2Z-100J-G9	
			5 m	XW2Z-500J-G9	
			10 m	XW2Z-10MJ-G9	
	Control cable (open-collector output for 1 axis)	Position control units (high-speed type) CJ1W-NC214 CJ1W-NC414	1 m	XW2Z-100J-G13	
			3 m	XW2Z-300J-G13	
	Control cable (line-driver output for 2 axis)	Position control units (high-speed type) CJ1W-NC234 CJ1W-NC434	1 m	XW2Z-100J-G13	
			5 m	XW2Z-500J-G1	
	Control cable (open-collector output for 2 axis)	Position control units (high-speed type) CJ1W-NC214 CJ1W-NC414	1 m	XW2Z-100J-G5	
			3 m	XW2Z-300J-G5	
	⑥	Terminal block cable for external signals (for input common, forward/reverse run prohibited inputs, emergency stop input, origin proximity input and interrupt input)	Position control units (high-speed type) CJ1W-NC234 CJ1W-NC434 CJ1W-NC214 CJ1W-NC414	0.5 m	XW2Z-C50X
				1 m	XW2Z-100X
				2 m	XW2Z-200X
3 m				XW2Z-300X	
5 m				XW2Z-500X	
10 m				XW2Z-010X	
⑦	Terminal block for external signals (M3 screw, pin terminals)		-	XW2B-20G4	
	Terminal block for ext. signals (M3.5 screw, fork/round terminals)		-	XW2B-20G5	
	Terminal block for ext. signals (M3 screw, fork/round terminals)		-	XW2D-20G6	
⑧	Cable from servo relay unit to servo drive	CS1W-NC1□3, CJ1W-NC1□3, C200HW-NC113, CS1W-NC2□3/4□3, CJ1W-NC2□3/4□3, C200HW-NC213/413, CQM1H-PLB21 or CQM1- CPU43	1m	XW2Z-100J-B25	
			2m	XW2Z-200J-B25	
			1m	XW2Z-100J-B31	
			2m	XW2Z-200J-B31	
⑨	Servo relay unit	Position control units CS1W-NC1□3, CJ1W-NC1□3 or C200HW-NC113	-	XW2B-20J6-1B (1 axis)	
			-	XW2B-40J6-2B (2 axes)	
			-	XW2B-20J6-3B (1 axis)	
			-	XW2B-20J6-8A (1 axis) XW2B-40J6-9A (2 axes)	
⑩	Position control unit connecting cable	CQM1H-PLB21	0.5 m	XW2Z-050J-A3	
			1 m	XW2Z-100J-A3	
		CS1W-NC113 or C200HW-NC113	0.5 m	XW2Z-050J-A6	
			1 m	XW2Z-100J-A6	
		CS1W-NC213/413 or C200HW-NC213/413	0.5 m	XW2Z-050J-A7	
			1 m	XW2Z-100J-A7	
		CS1W-NC133	0.5 m	XW2Z-050J-A10	
			1 m	XW2Z-100J-A10	
		CS1W-NC233/433	0.5 m	XW2Z-050J-A11	
			1 m	XW2Z-100J-A11	
		CJ1W-NC113	0.5 m	XW2Z-050J-A14	
			1 m	XW2Z-100J-A14	
		CJ1W-NC213/413	0.5 m	XW2Z-050J-A15	
			1 m	XW2Z-100J-A15	
		CJ1W-NC133	0.5 m	XW2Z-050J-A18	
			1 m	XW2Z-100J-A18	
CJ1W-NC233/433	0.5 m	XW2Z-050J-A19			
	1 m	XW2Z-100J-A19			
CJ1M-CPU21/22/23	0.5 m	XW2Z-050J-A33			
	1 m	XW2Z-100J-A33			
⑪	General purpose cable	For general purpose controllers	1 m	R88A-CPG001S	
			2 m	R88A-CPG002S	
⑫	Terminal block cable	For general purpose controllers	1 m	XW2Z-100J-B24	
			2 m	XW2Z-200J-B24	
⑬	Terminal block (M3 screw and for pin terminals)		-	XW2B-50G4	
	Terminal block (M3.5 screw and for fork/round terminals)		-	XW2B-50G5	
	Terminal block (M3 screw and for fork/round terminals)		-	XW2D-50G6	

Analog monitor (for CN5)

Symbol	Name		Model
⑭	Analog monitor cable	1m	R88A-CMK001S

USB personal computer cable (for CN7)

Symbol	Name		Model
⑮	USB mini-connector cable	2m	AX-CUSBM002-E

External regenerative resistor

Symbol	Regenerative resistor unit model	Specifications
⑯	R88A-RR08050S	50 Ω, 20 W
	R88A-RR080100S	100 Ω, 20 W
	R88A-RR22047S	47 Ω, 70 W
	R88A-RR50020S	20 Ω, 180 W

Cable for Safety Functions (for CN8)

Symbol	Description	Model
⑰	Safety connector with 3 m cable (with loose wires at one end)	R88A-CSK003S-E

Filters

Symbol	Applicable servodrive	Filter model	Rated current	Leakage current	Rated voltage
⑱	R88D-KT02H-L	R88A-FIK102-RE	2.4 A	3.5 mA	250 VAC single-phase
	R88D-KT04H-L	R88A-FIK104-RE	4.1 A	3.5 mA	
	R88D-KT08H-L	R88A-FIK107-RE	6.6 A	3.5 mA	
	R88D-KT10H-L, R88D-KT15H-L	R88A-FIK114-RE	14.2 A	3.5 mA	400 VAC three-phase
	R88D-KT06F-L, R88D-KT10F-L, R88D-KT15F-L	R88A-FIK304-RE	4 A	0.3 mA / 32 mA ¹	
	R88D-KT20F-L	R88A-FIK306-RE	6 A	0.3 mA / 32 mA ¹	
R88D-KT30F-L, R88D-KT50F-L	R88A-FIK312-RE	12.1 A	0.3 mA / 32 mA ¹		

1. Momentary peak leakage current for the filter at switch-on/off.

Connectors

Specifications	Model
I/O connector kit -50 pins-(for CN1)	R88A-CNU11C
External encoder connector (for CN4)	R88A-CNK41L
Safety I/O signal connector (for CN8)	R88A-CNK81S

Computer software

Specifications	Model
Configuration and monitoring software tool for servo drives and inverters. (CX-drive version 2.4 or higher)	CX-drive

ALL DIMENSIONS SHOWN ARE IN MILLIMETERS.
To convert millimeters into inches, multiply by 0.03937. To convert grams into ounces, multiply by 0.03527.

R88D-GN□, R88D-GT□

G-Series servo drive

A compact servo drive family for motion control. Compact size and integrated MECHATROLINK-II motion bus.

- ML2 and Analog/ Pulse servo drive models
- High-response frequency of 1 kHz
- Auto-tuning for easy and quick start-up
- Vibration suppression
- Positioning, speed or torque control
- Separate power and control power supply
- Fast and accurate positioning
- Incremental and absolute encoder

Ratings

- 230 VAC Single-phase 100 W to 1.5 kW (8.62 Nm)



System configuration

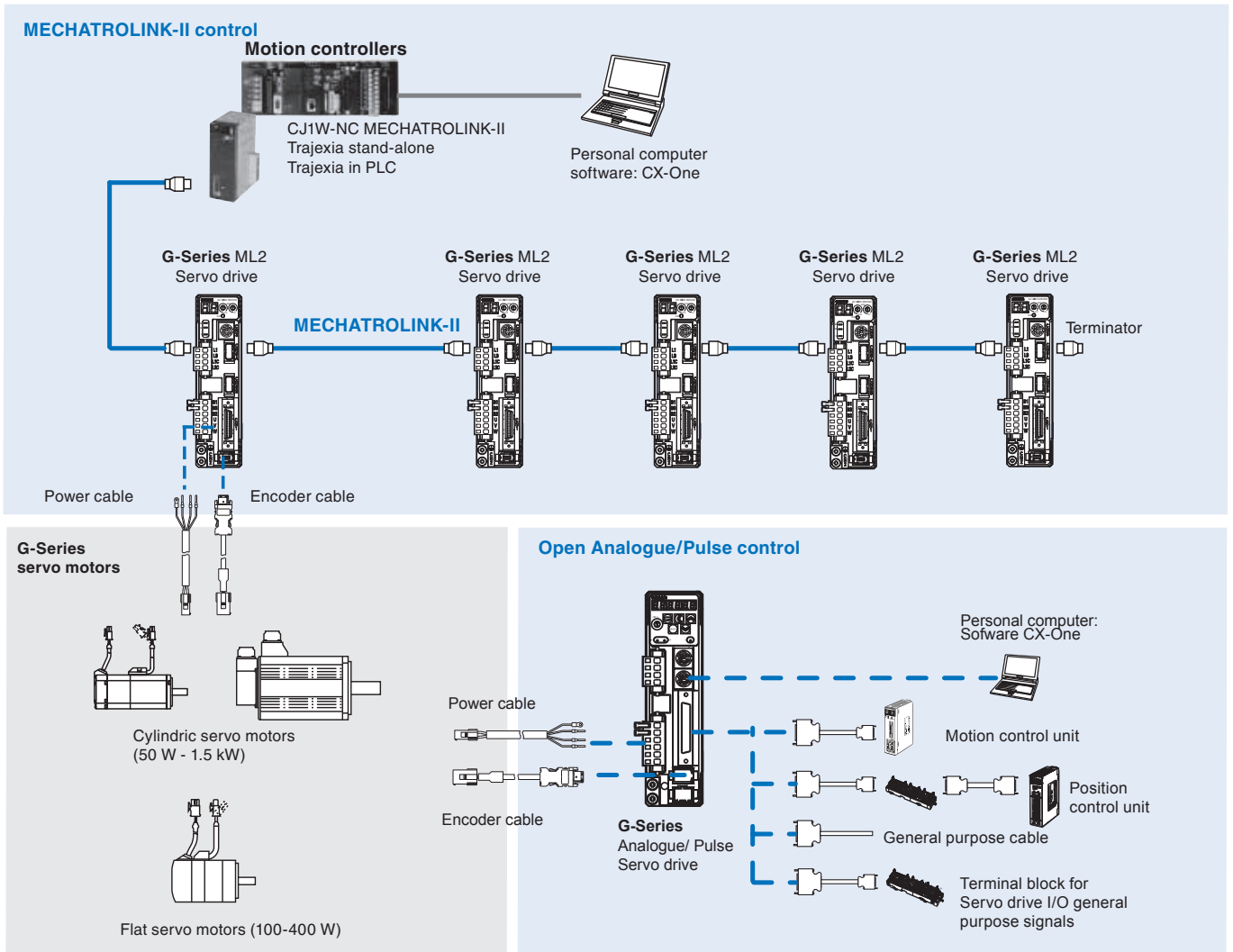

Servo motor supported

Servo motor							G-Series servo drive			
Family	Voltage	Speed	Rated torque	Capacity	Model	MECHATROLINK-II	Analog/ Pulse			
Cylindric	50 - 750 W	230 V	3000 min ⁻¹	0.16 Nm	50 W	R88M-G05030□-□S2	R88D-GN01H-ML2	R88D-GT01H		
				0.32 Nm	100 W	R88M-G10030□-□S2	R88D-GN01H-ML2	R88D-GT01H		
				0.64 Nm	200 W	R88M-G20030□-□S2	R88D-GN02H-ML2	R88D-GT02H		
				1.3 Nm	400 W	R88M-G40030□-□S2	R88D-GN04H-ML2	R88D-GT04H		
				2.4 Nm	750 W	R88M-G75030□-□S2	R88D-GN08H-ML2	R88D-GT08H		
	900 - 1500 W	230 V	3000 min ⁻¹	3.18 Nm	1000 W	R88M-G1K030T-□S2	R88D-GN15H-ML2	R88D-GT15H		
				4.77 Nm	1500 W	R88M-G1K530T-□S2	R88D-GN15H-ML2	R88D-GT15H		
				2000 min ⁻¹	4.8 Nm	1000 W	R88M-G1K020T-□S2	R88D-GN10H-ML2	R88D-GT10H	
				7.15 Nm	1500 W	R88M-G1K520T-□S2	R88D-GN15H-ML2	R88D-GT15H		
				1000 min ⁻¹	8.62 Nm	900 W	R88M-G90010T-□S2	R88D-GN15H-ML2	R88D-GT15H	
Flat	100-400 W	230 V	3000 min ⁻¹	0.32 Nm	100 W	R88M-GP10030□-□S2	R88D-GN01H-ML2	R88D-GT01H		
				0.64 Nm	200 W	R88M-GP20030□-□S2	R88D-GN02H-ML2	R88D-GT02H		
				1.3 Nm	400 W	R88M-GP40030□-□S2	R88D-GN04H-ML2	R88D-GT04H		

Type designation

Servo drive

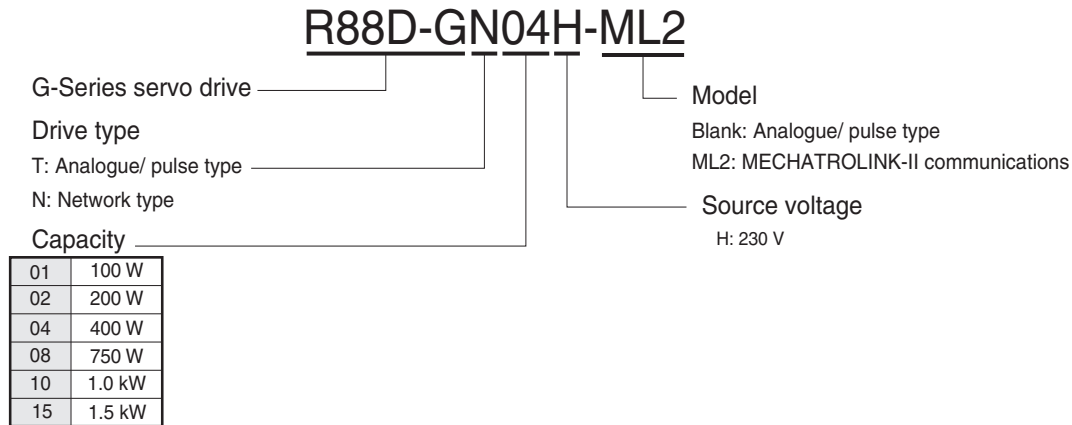

Servo drive specifications

General specifications

Servo drive type		R88D-G□	01H□	02H□	04H□	08H□	10H□	15H□	
Applicable servomotor	R88M-G□	05030□/10030□	20030□	40030□	75030□	G1K020T□	90010T□ / 1K030T□ / 1K5□0T□		
	R88M-GP□	10030□	20030□	40030□	-	-	-		
Max. applicable motor capacity	W	100	200	400	750	1000	1500		
Continuous output current	Arms	1.16	1.6	2.7	4.0	5.9	9.8		
Max. output current	Arms	3.5	5.3	7.1	14.1	21.2	28.3		
Input power	Main circuit	For single-phase, 200 to 240 VAC +10 to -15% (50/60 Hz)				For single-phase/three-phase, 200 to 240 VAC +10 to -15% (50/60 Hz)			
	Control circuit	For single-phase, 200 to 240 VAC + 10 to -15% (50/60 Hz)							
Supply	Control circuit	For single-phase, 200 to 240 VAC + 10 to -15% (50/60 Hz)							
Control method	IGBT-driven PWM method								
Feedback	Serial encoder (incremental/absolute)								
Conditions	Usage/storage temperature	0 to +55 °C / -20 to 65 °C							
	Usage/storage humidity	90% RH or less (non-condensing)							
	Altitude	1000m or less above sea level							
	Vibration/shock resistance	5.88 m/s ² / 19.6 m/s ²							
Configuration	Base mounted								
Approx. weight	Kg	0.8	1.1	1.5	1.7				

MECHATROLINK-II servo drive specifications

Position/Speed/torque control mode	Performance	Speed variance	Load variance	During 0 to 100% load ± 0.01 max. (at rated speed)	
			Voltage variance	0% at $\pm 10\%$ of rated voltage (at rated speed)	
			Temperature variance	0 to 50°C $\pm 0.1\%$ max. (at rated speed)	
		Frequency characteristics		1 kHz	
		Torque control accuracy (reproducibility)		$\pm 3\%$ (at 20% to 100% of rated torque)	
		Soft start time setting			0 to 10 s (acceleration time and deceleration time can be set)
Command Input	MECHATROLINK Communication		MECHATROLINK-II commands (for sequence, motion, data setting/reference, monitor, adjustment and other commands)		
I/O signal	Sequence input signal		Emergency stop, 3 external latch signals, forward/reverse torque limit, forward/reverse run prohibit, origin proximity, 3 general-purpose inputs		
	Sequence output signal		It is possible to output three types of signals: positioning completed, speed coincidence, rotation speed detection, servo ready, current limit, speed limit, brake release and warning signal		
Integrated functions	Communications	RS-232 communications	Interface	Personal computer	
			Transmission rate	From 2400 to 57600 bps	
			Functions	Parameter setting, status display, alarm display (monitor, clear, history), servo drive data tracing function, test run/autotuning operations, real time trace, absolute encoder setting, default values function	
	Communications	MECHATROLINK communications	Communications protocol	MECHATROLINK-II	
			Transmission rate	10 Mbps	
			Data length	32 bytes	
	Tuning		Parameter setting, status display, alarm display (monitor, clear, history), default values function		
	Dynamic brake (DB)		Horizontal and vertical axis mode. One parameter rigidity setting. Load inertia detection.		
	Regenerative processing		Operates when main power OFF, servo alarm, overtravel or servo OFF		
	Overtravel (OT) prevention function		Built-in regeneration resistor in models from 750 W to 1.5 kW. External regeneration resistor optionally.		
	Emergency stop (STOP)		Dynamic brake, disables torque or emergency stop torque during POT and NOT operation		
	Encoder divider function		Emergency stop input		
Electronic gearing		Optional division pulses possible			
Internal speed setting function		0,01<Numerator/Denominator<100			
Protective functions		8 internal speeds			
Analog monitor Output		Overvoltage, undervoltage, overcurrent, overload, regeneration overload, servo drive overheat			
Panel operator	Display functions		The actual servomotor speed, command speed, torque and number of accumulated pulses can be measured using an oscilloscope or other device.		
	Switches		A 2-digit 7-segment LED display shows the servo drive status, alarm codes, parameters, etc.		
			MECHATROLINK-II communications status LED indicator (COM)		
		Rotary switch for setting the MECHATROLINK-II node address			

Analog/pulse servo drive specifications

Control mode		Position, speed and torque control mode			
Performance	Speed variance	Load variance	During 0 to 100% load ± 0.01 max. (at rated speed)		
		Voltage variance	0% at $\pm 10\%$ of rated voltage (at rated speed)		
		Temperature dependence	0 to 50°C $\pm 0.1\%$ max. (at rated speed)		
	Frequency characteristics		1 kHz		
	Torque control accuracy (reproducibility)		$\pm 3\%$ (at 20% to 100% of rated torque)		
	Soft start time setting				0 to 10 s (acceleration time and deceleration time can be set)
Position control	Input signal	Command pulse	Input pulse type	Signal + pulse, 90° phase displacement 2-phase pulse (phase A/B) or reverse and forward pulses (CW/CCW)	
			Input pulse frequency	500 kpps max. line-driver input, 200 kpps max. open-collector input	
			Electronic gearing	0,01<Numerator/Denominator<100	
Speed/torque control	Input signal	Speed control	Speed reference voltage	10 VDC at 3000 r/min: set at delivery (the scale can be set by parameters)	
			Torque limit	3 VDC at rated torque (torque can be limited separately in positive/negative direction)	
		Torque control	Preset speed control	Preset speed is selectable from 8 internal settings by digital inputs.	
			Torque reference voltage	3 VDC at rated torque: set at delivery (the scale and polarity can be set by parameters).	
		Speed limit	Speed limit can be set by parameter.		
I/O signal	Sequence input signal		Forward/reverse run prohibit, deviation counter reset, alarm reset, control mode switch, pulse prohibited, speed selection, gain switch, zero speed designation, origin proximity		
	Sequence output signal		Brake release, servo ready and alarm output. It is possible also to output two types of configurable signals: current limit, rotation speed detection, warning signal, speed coincidence, positioning completed		

Communications	RS-232 communications	Interface	Personal computer	
		Transmission rate	From 2400 to 57600 bps	
	RS-485 communications data	Interface	Communication data interface between servo drives and personal computer.	
		Transmission rate	From 2400 to 57600 bps	
Integrated functions	Functions		Parameter setting, status display, alarm display (monitor, clear, history), servo drive data tracing function, test run/autotuning operations, real time trace, absolute encoder setting, default values function	
	Tuning		Horizontal and vertical axis mode. One parameter rigidity setting. Load inertia detection.	
	Dynamic brake (DB)		Operates when main power OFF, servo alarm, overtravel or servo OFF	
	Regenerative processing		Built-in regeneration resistor in models from 750 W to 1.5 kW. External regeneration resistor optionally.	
	Overtravel (OT) prevention function		Dynamic brake, disables torque or emergency stop torque during POT and NOT operation	
	Emergency stop (STOP)		Emergency stop input	
	Encoder divider function		Optional division pulses possible	
	Protective functions		Overvoltage, undervoltage, overcurrent, overload, regeneration overload, servo drive overheat	
	Analog monitor Output		The actual servomotor speed, command speed, torque and number of accumulated pulses can be measured using an oscilloscope or other device.	
	Panel operator	Display functions	A 6-digit 7-segment LED display shows the servo drive status, alarm codes, parameters, etc.	
		Switches	Unit No. switch for serial communications. Value from 0 to F. To identify which servo drive the computer is accessing in RS232C communications when multiple servo drives.	

Servo drive part names

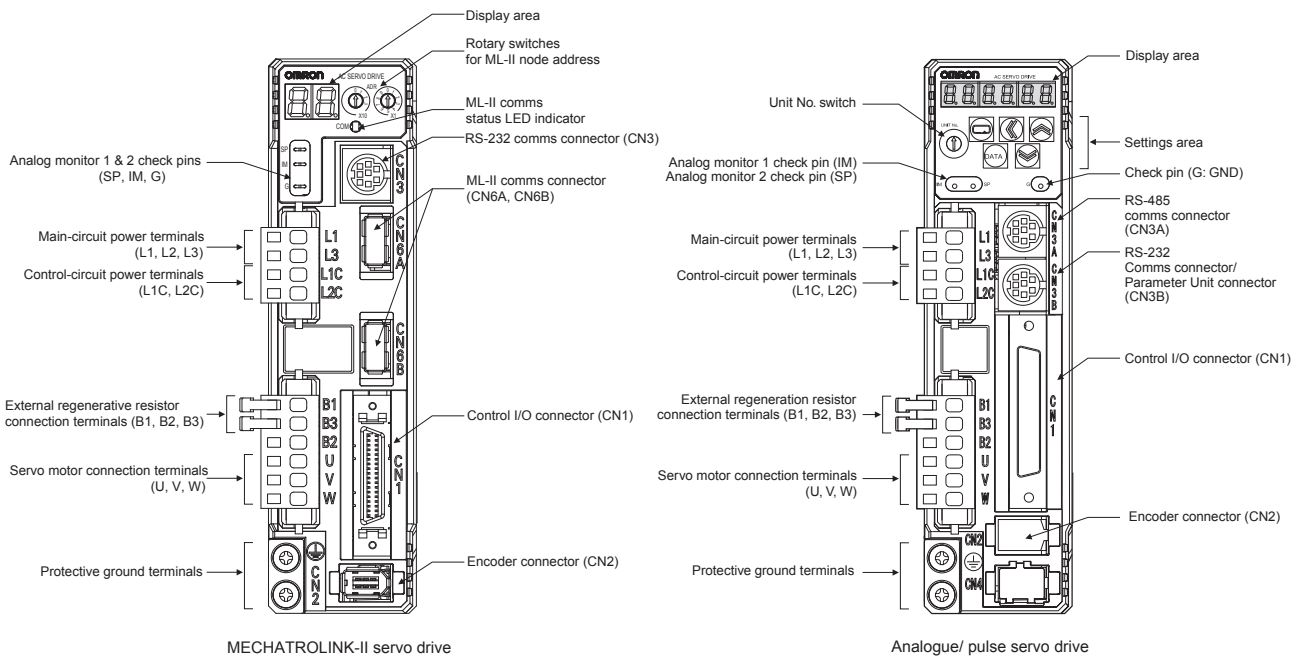

I/O specifications

Main circuit connector (CNA) specifications

Symbol	Name	Function
L1	Main circuits power supply input	AC power input terminals for the main circuit Note: for single-phase connect the power supply input to L1 and L3
L2		
L3		
L1C	Control circuit power supply input	AC power input terminals for the control circuit
L2C		

Servomotor connector (CNB) specifications

Symbol	Name	Function
B1	External regeneration resistor connection terminals	Up to 400 W: If regenerative energy is high, connect an external regeneration resistor between B1 and B2. From 750 W to 1.5kW: Normally B2 and B3 are connected. If regenerative energy is high, remove the short-circuit bar between B2 and B3 and connect an external regeneration resistor between B1 and B2.
B2		
B3		
U	Servo motor connection terminals	Terminals for outputs to the servomotor.
V		
W		
⊕		
⊕	Frame ground	Ground terminal. Ground to 100Ω or less.

I/O signals (CN1) - Input signals (for MECHATROLINK-II servo drives)

Pin No.	Signal name	Function	
1	+24VIN	Control power supply input for sequence signals: users must provide the +24 V power supply. Allowable voltage range: 12 to 24 VDC	
2	STOP	Emergency Stop Input	Input for emergency stop. Emergency stop function factory default: enable.
3	EXT3	External Latch Signals	This external signal input latches the current value feedback pulse counter. Minimal signal width must be 1 ms.
4	EXT2		
5	EXT1		
22	IN1	External general-purpose Input 0	This input is used as external general-purpose input.
6	IN0	External general-purpose Input 1	
23	IN2	External general-purpose Input 2	This signal input selects the torque limit.
7	PCL	Forward Torque Limit Input	
8	NCL	Reverse Torque Limit Input	Forward/ reverse drive rotation overtravel input. Stops servomotor when movable part travels beyond the allowable range of motion.
19	POT	Forward Run Prohibit Input	
20	NOT	Reverse Run Prohibit Input	Connect the origin proximity input signal in the origin search operation.
21	DEC	Origin Proximity Input	
34	BAT	Battery backup input for absolute encoder	Connecting pin for the absolute backup battery. Do not connect when a battery is connected to the servomotor encoder cable.
33	BATCOM		

I/O signals (CN1) - output signals (for MECHATROLINK-II servo drives)

Pin No.	Signal name	Function
15	/ALM	The output turns OFF when an alarm is generated in the Servo drive.
16	ALMCOM	
29	OUTM2	General-purpose output. The function for this output is selected by changing the parameter: INP1 (Positioning completed), VCMP (Speed conformity signal), TGON (Servomotor rotation speed detection), READY (Servo ready), CLIM (Current limit detection), VLIM (Speed limit detection), BKIR (Brake interlock), WARN (Warning signal)
30	OUTM2COM	
31	OUTM3	
32	OUTM3COM	
36	OUTM1	
35	OUTM1COM	

I/O signals (CN1) - Input signals (for analog/pulse servo drives)

Pin No.	Control mode	Signal name	Function
1	Position	+24 V _{CW}	Reference pulse input for line driver and open collector according to parameter setting.
3		+CW	
4		-CW	Input mode: Sign + pulse string
2		+24 V _{CCW}	
5		+CCW	Reverse/forward pulse (CCW/CW pulse)
6		-CCW	
44		+CW _L D	Reference pulse input for line driver only.
45		-CW _L D	
46		+CCW _L D	Input mode: Reverse/forward pulse (CW/CCW pulse)
47		-CCW _L D	
14	Speed	REF	Speed reference input: ±10 V/rated motor speed (input gain can be modified using a parameter).
Torque		TREF1	Torque reference input: ±10 V/rated motor torque (input gain can be modified using a parameter).
		VLIM	Speed limit input: ±10 V/rated motor speed (input gain can be modified using a parameter).
15	-	AGND1	Analog signal ground
16	Torque	TREF2	Torque reference input: ±10 V/rated motor torque (input gain can be modified using a parameter).
Position/Speed		PCL	Forward torque limit input: ±10 V/rated motor torque (input gain can be modified using a parameter).
	18		NCL
17	-	AGND	Analog signal ground

Pin No.	Control mode	Signal name	Function		
7	Common	+24 VIN	Control power supply input for sequence signals: users must provide the +24 V power supply (12 to 24 V).		
29		RUN	Servo ON: this turn ON the servo.		
26	Position	DFSEL	Vibration filter switching	Enables vibration filter according parameter setting.	
	Speed	PNSSEL	Speed command rotation direction switch		
27	Common	VZERO	Zero speed designation	Speed command is regarded as 0. This function is enable/disabled by parameter.	
		GSEL	Gain switching		
28	Common	TLSEL	Torque limit switch.		
		GESEL	Electronic gear switching	Switches the numerator for electronic gear ratio.	
30	Position	ECRST	Error counter reset input.		Resets the position error counter.
30	Speed	VSEL2	Internal speed selection 2		
31	Common	RESET	Alarm reset input.	Release the alarm status. The error counter is reset when the alarm is reset.	
32	Position/ Speed/Torque	TVSEL	Control mode switching	Position ↔ speed } Position ↔ torque } Enables control mode switching Torque ↔ speed }	
33		Position	IPG		Pulse prohibition input. Digital input to inhibit the position reference pulse.
33		Speed	VSEL1		Internal speed selection 1
8	Common	NOT	Reverse run prohibited	Overtravel prohibited: stops servomotor when movable part travels beyond the allowable range of motion.	
9		POT	Forward run prohibited		
20	Common	SEN	Sensor ON input. Initial data request signal when using an absolute encoder.		
13		SENGND	Sensor ON signal ground.		
42	Common	BAT (+)	Backup battery connection terminals when the absolute encoder power is interrupted. Do not connect when an absolute encoder battery cable for backup is used.		
43		BATGND (-)			
50		FG	Frame ground		

I/O signals (CN1) - Output signals (for analog/pulse servo drives)

Pin No.	Control mode	Signal name	Function		
21	Common	+A	Encoder phase A+	Encoder signals are output according Encoder Dividing Numerator parameter. This is the line-driver output (equivalent to R422).	
22		-A	Encoder phase A-		
49		+B	Encoder phase B+		
48		-B	Encoder phase B-		
23		+Z	Encoder phase Z+		
24		-Z	Encoder phase Z-		
19		Z	Encoder phase-Z output		Phase Z is output for encoder signals. Open-collector output.
25		ZCOM	Encoder phase-Z common		
11		BKIR	Brake release signal output		Timing signal for operating the electromagnetic brake on a motor.
10		BKIRCOM			
35		READY	Servo ready: ON if there is not servo alarm when the control/main circuit power supply is turned ON.		
34		READYCOM			
37		/ALM	Servo alarm: turns OFF when an error is detected.		
36		ALMCOM			
39	Speed/torque	TGON	Motor rotation speed detection. This output turns ON when the motor rotation speed reaches the speed set in a parameter.		
38		TGONCOM			
39	Position	INP	Positioning complete output: turns ON when position error is equal to setting parameter.		
38		INPCOM			
-	-	INP2	Position complete output 2	The function of output signals allocated to pins 11, 10, 34 to 39 can be changed with these options by parameters settings.	
		P-CMD	Position command status		
		ZSP	Zero speed		
		WARN1	Warning 1		
		WARN2	Warning 2		
		ALM-ATB	Alarm output		
		VCMP	Speed conformity output		
		V-CMD	speed command status		
		V-LIMIT	Speed limit detection		
		T-LIMIT	Torque limit detection		
12	Common	OUTM1	General-purpose Output 1	Use the parameter settings to assign the desired function	
40		OUTM2	General-purpose Output2		
41		COM	General-purpose common		Output ground common

Dimensions

Servo drives

R88D-GN01/02H-ML2, R88D-GT01/02H (200 V, 100 to 200 W)

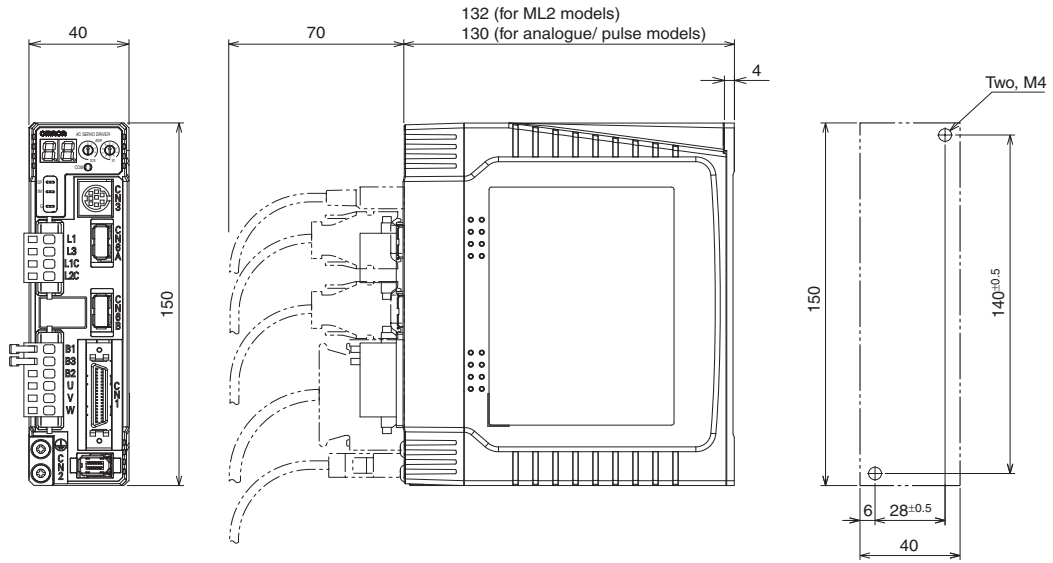

R88D-GN04H-ML2, R88D-GT04H (200 V, 400 W)

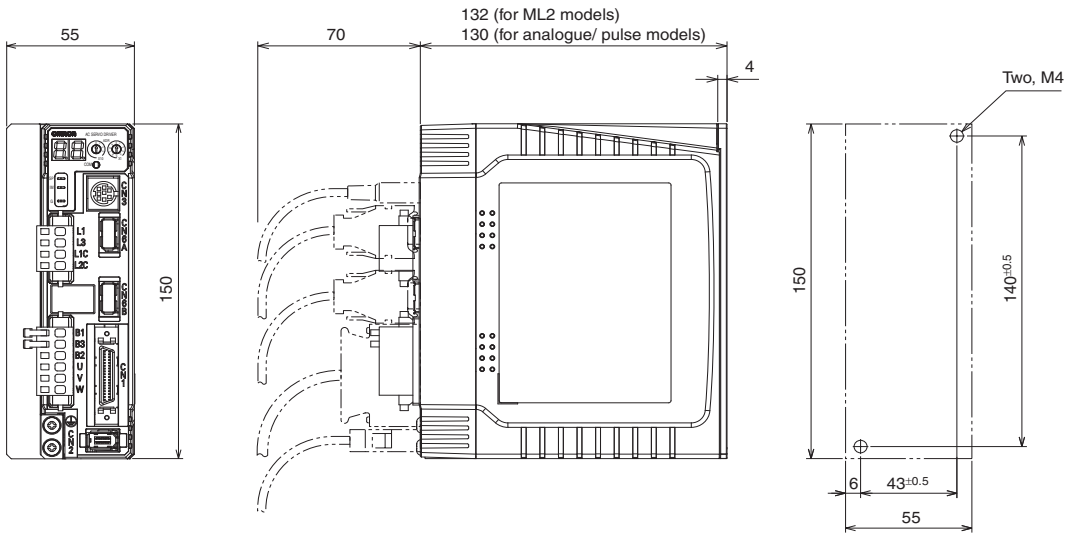

R88D-GN08H-ML2, R88D-GT08H (200 V, 750 W)

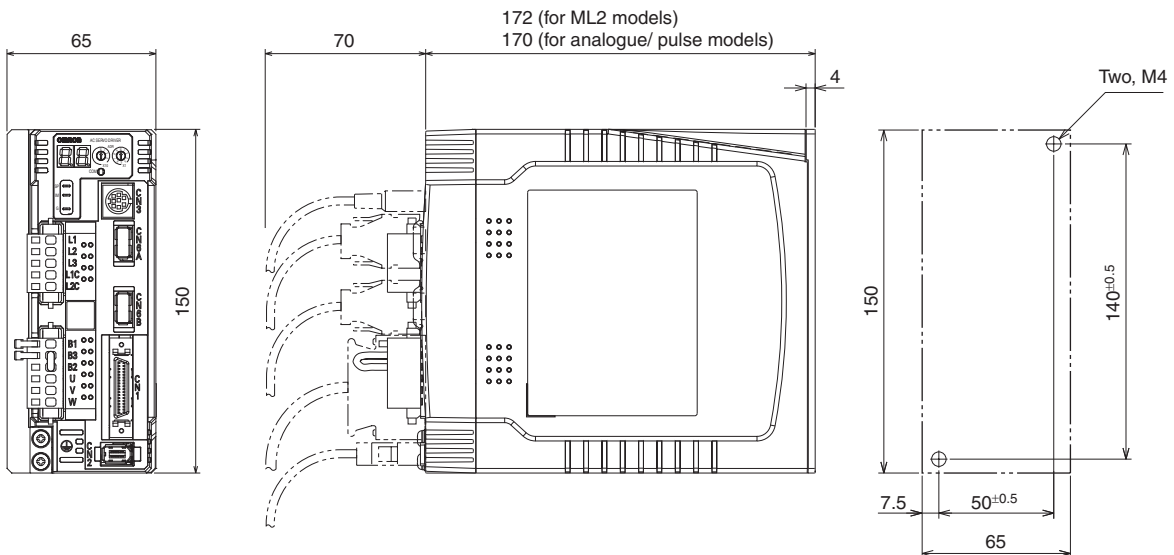

AC Servo systems

R88D-GN10/15H-ML2, R88D-GT10/15H (200 V, 1 kW to 1,5 kW)

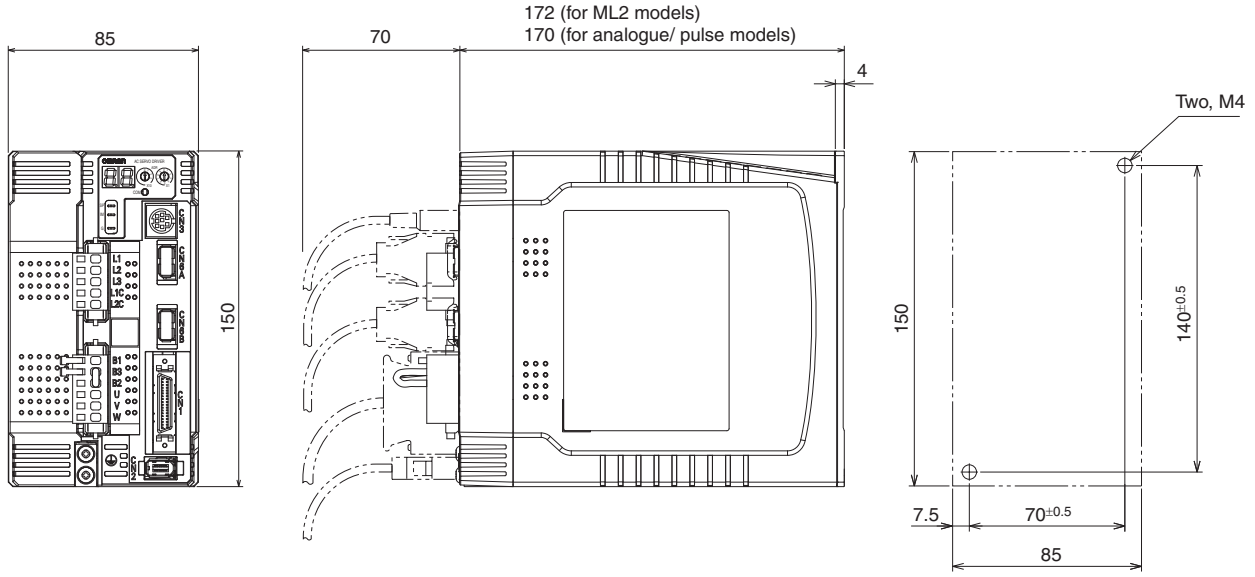

Filters

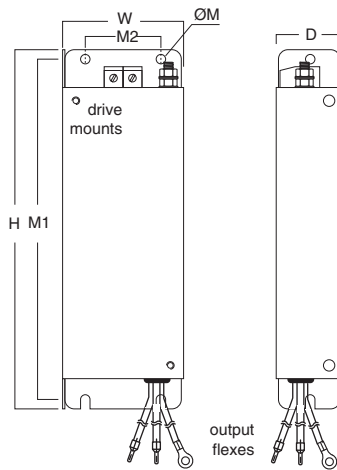

Filter model	Rated current	Leakage current	External dimensions				Mount dimensions		Filter Fixing	Rated voltage
			H	W	D	M1	M2			
R88A-FIK102-RE	2.4 A	3.5 mA	190	42	44	180	20	M4	250 VAC single-phase	
R88A-FIK104-RE	4.1 A	3.5 mA	190	57	30	180	30	M4		
R88A-FIK107-RE	6.6 A	3.5 mA	190	64	35	180	40	M4		
R88A-FIK114-RE	14.2 A	3.5 mA	190	86	35	180	60	M4		

Installation

Single-phase, 230 VAC

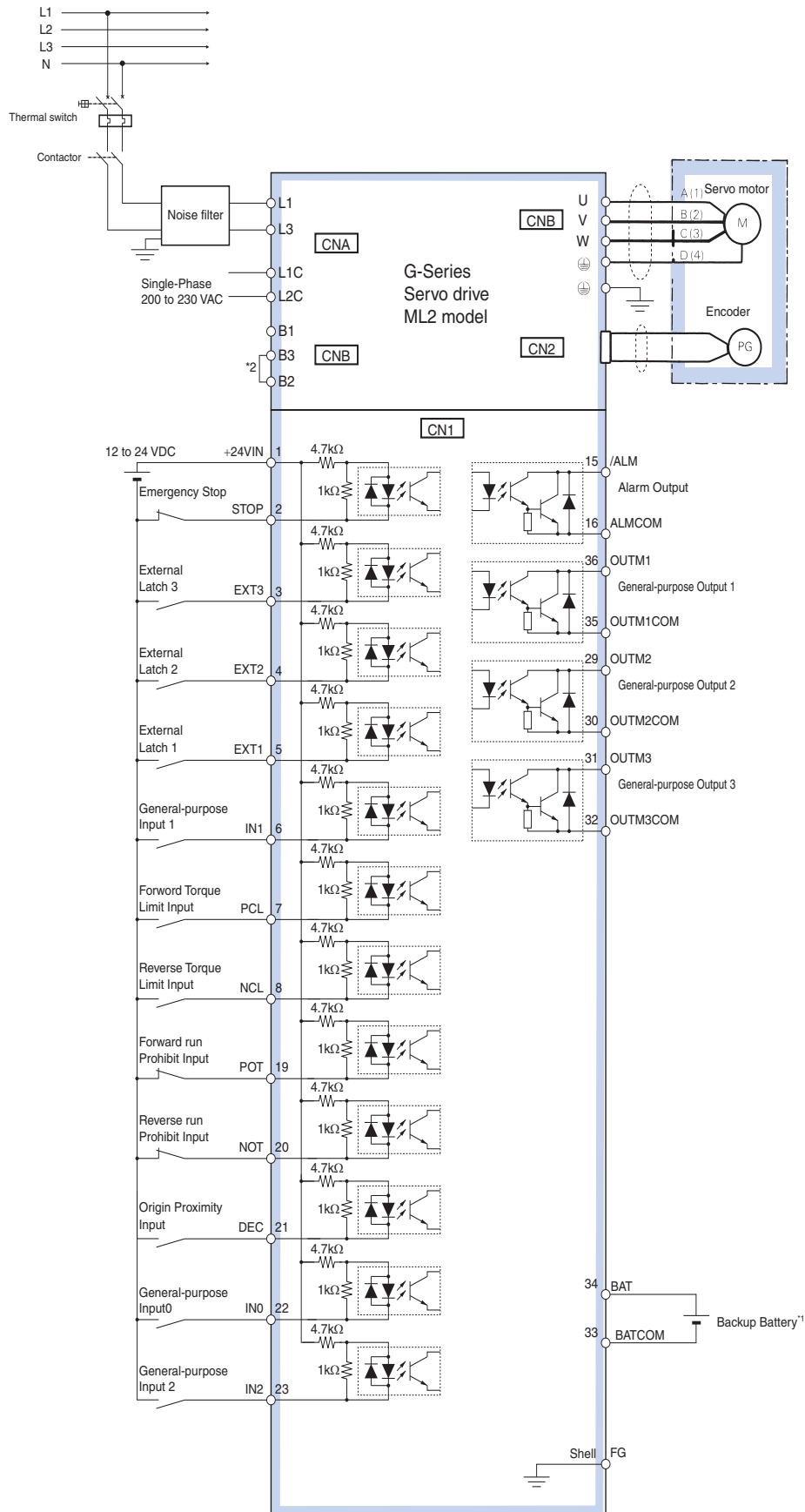

*1 For use only with an absolute encoder. If a backup battery is connected to CN1 I/O connector, an encoder cable with a battery is not required.

*2 For servo drives from 750 W, B2 and B3 are short-circuited. If the internal regenerative resistor is insufficient, remove the wire between B2 and B3 and connect an external resistor between B1 and B2.

Single-phase, 230 VAC

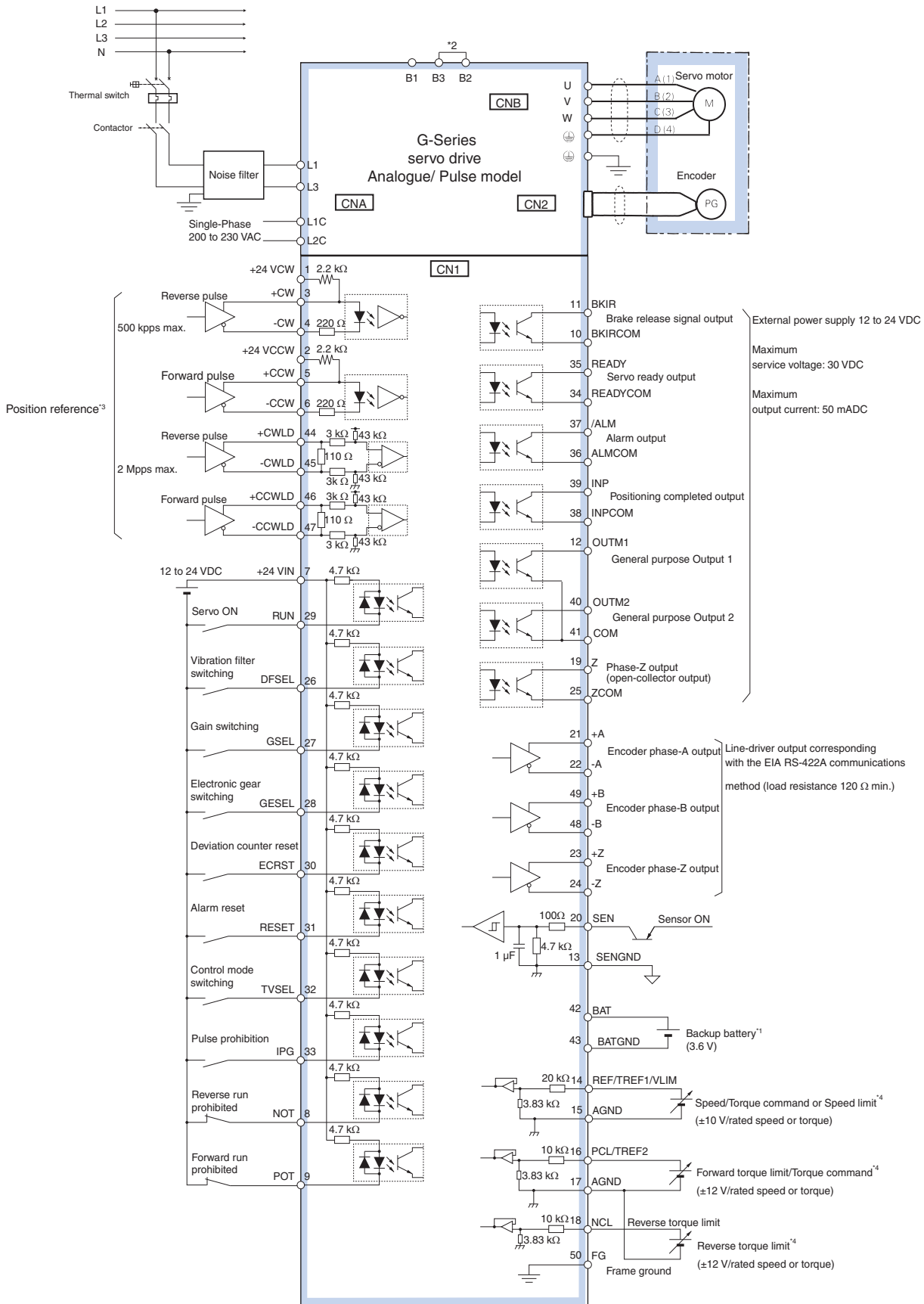

*1 For use only with an absolute encoder. If a backup battery is connected to CN1 I/O connector, an encoder cable with a battery is not required.
 *2 For servo drives from 750 W, B2 and B3 are short-circuited. If the internal regenerative resistor is insufficient, remove the wire between B2 and B3 and connect an external resistor between B1 and B2.
 *3 Only available in Position control mode.
 *4 The input function depends on control mode used (Position, speed or torque control).

Ordering information

G-Series MECHATROLINK-II model reference configuration

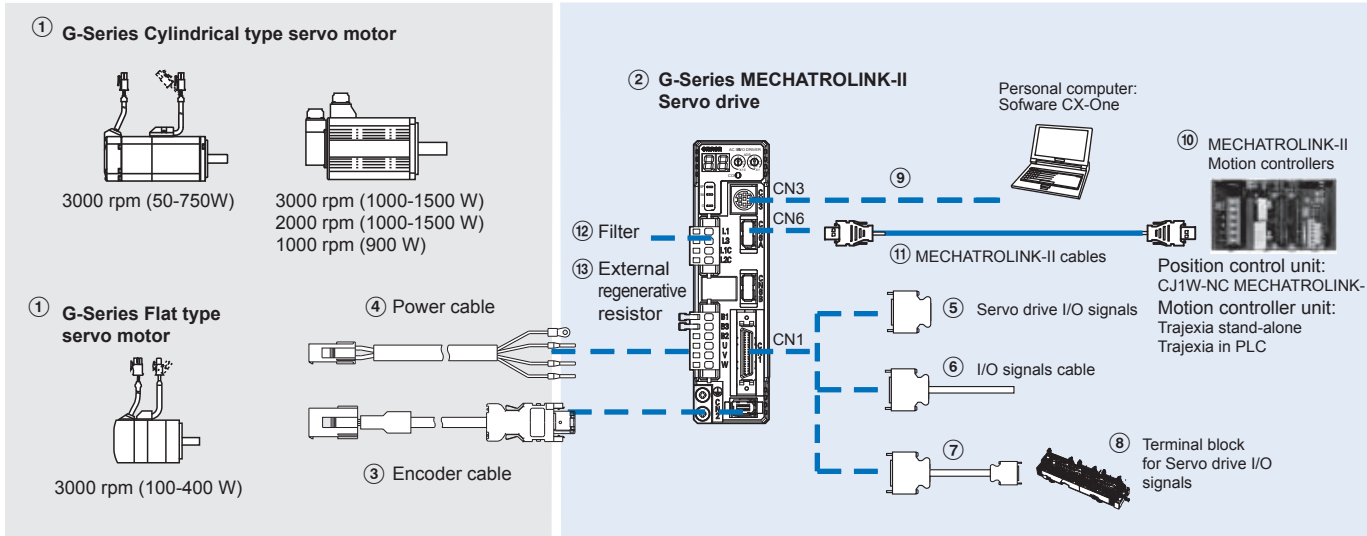

Note: The symbols ①②③④⑤... show the recommended sequence to select the components in a G-Series servo system

Servo motors, power & encoder cables

Note: ①③④ Refer to the G-Series servo motor chapter for servomotor, motor cables or connectors selection

Servo drives

②	Specifications	Servo drive model	① Compatible rotary servo motors	
			Cylindric type	Flat type
1 phase 200 VAC	100 W	R88D-GN01H-ML2	R88M-G05030□ R88M-G10030□	R88M-GP10030□
	200 W	R88D-GN02H-ML2	R88M-G20030□	R88M-GP20030□
	400 W	R88D-GN04H-ML2	R88M-G40030□	R88M-GP40030□
	750 W	R88D-GN08H-ML2	R88M-G75030□	-
	1.0 kW	R88D-GN10H-ML2	R88M-G1K020T□	-
	1.5 kW	R88D-GN15H-ML2	R88M-G90010T□	-
			R88M-G1K030T□	-
R88M-G1K520T□			-	
R88M-G1K530T□			-	

Control cables (for CN1)

Symbol	Name	Connect to	Model	
⑤	I/O connector kit	Servo drive I/O signals	R88A-CNU01C	
⑥	General purpose cable		1 m	R88A-CPGB001S-E
			2 m	R88A-CPGB002S-E
			⑦	Terminal block cable
⑧	Terminal block		2 m	XW2Z-200J-B33
			-	XW2B-20G4
			XW2B-20G5	
				XW2D-20G6

Computer cable (for CN3)

Symbol	Name	Model
⑨	Computer cable RS232	2 m R88A-CCG002P2

MECHATROLINK-II Motion controllers

Symbol	Name	Model
⑩	Trajexia stand-alone motion controller	TJ2-MC64 (64 axes)
		TJ1-MC16 (16 axes)
		TJ1-MC04 (4 axes)
	Trajexia-PLC motion controller	CJ1W-MCH72 (30 axes)
		CJ1W-MC472 (4 axes)
	Position Controller Unit for CJ1 PLC	CJ1W-NCF71 (16 axes)
		CJ1W-NC471 (4 axes)
		CJ1W-NC271 (2 axes)
	Position Controller Unit for CS1 PLC	CS1W-NCF71 (16 axes)
		CS1W-NC471 (4 axes)
		CS1W-NC271 (2 axes)

MECHATROLINK-II cables (for CN6)

Symbol	Specifications	Length	Model
⑪	MECHATROLINK-II Terminator resistor	-	JEPMC-W6022-E
	MECHATROLINK-II cables	0.5 m	JEPMC-W6003-A5-E
		1 m	JEPMC-W6003-01-E
		3 m	JEPMC-W6003-03-E
		5 m	JEPMC-W6003-05-E
		10 m	JEPMC-W6003-10-E
		20 m	JEPMC-W6003-20-E
		30 m	JEPMC-W6003-30-E

Filters

Symbol	Applicable servodrive	Filter model	Rated current	Leakage current	Rated voltage
⑫	R88D-GN01H□	R88A-FIK102-RE	2.4 A	3.5 mA	250 VAC single-phase
	R88D-GN02H□				
	R88D-GN04H□	R88A-FIK104-RE	4.1 A	3.5 mA	
	R88D-GN08H□				
	R88D-GN10H□	R88A-FIK114-RE	14.2 A	3.5 mA	
	R88D-GN15H□				

External regenerative resistor

Symbol	Regenerative resistor unit model	Specifications
⑬	R88A-RR08050S	50 Ω, 80 W
	R88A-RR080100S	100 Ω, 80 W
	R88A-RR22047S	47 Ω, 220 W
	R88A-RR50020S	20 Ω, 500 W

Computer software

Specifications	Model
Configuration and monitoring software tool for servo drives and inverters. (CX-drive version 1.70 or higher)	CX-drive
Complete OMRON software package including CX-drive. (CX-One version 3.10 or higher)	CX-One

Ordering information

G-Series Analog/pulse model reference configuration

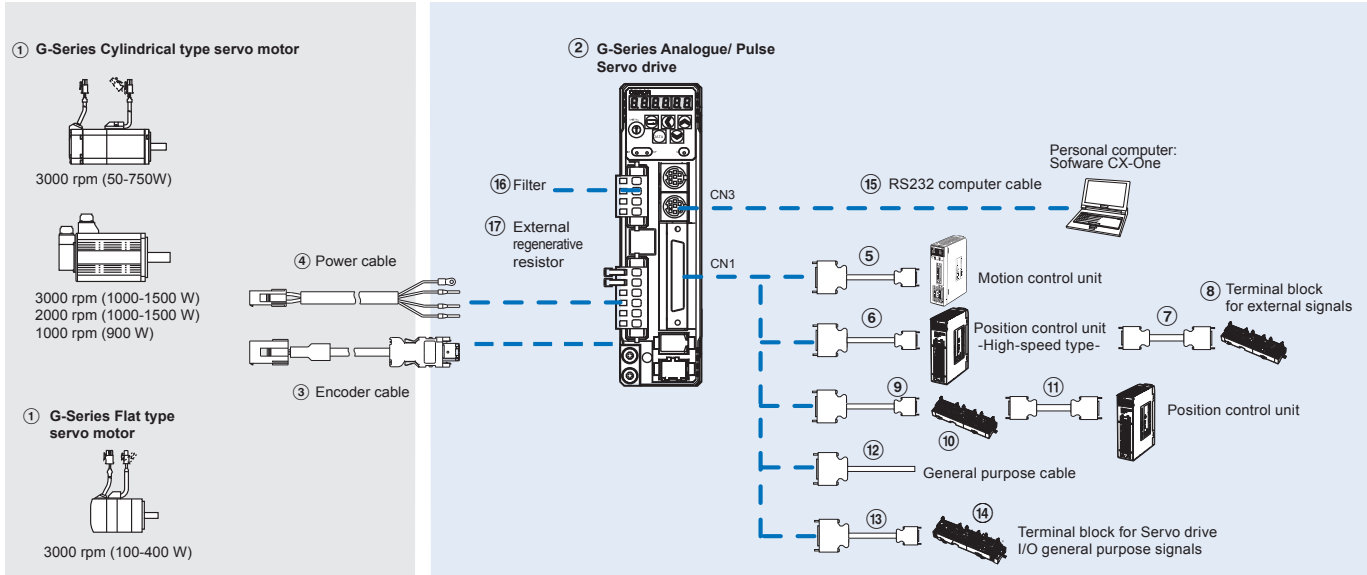

Note: The symbols ①②③④⑤... show the recommended sequence to select the components in a G-Series servo system

Servo motors, power & encoder cables

Note: ①③④ Refer to the G-Series servo motor chapter for servomotor, motor cables or connectors selection

Servo drives

Specifications	Servo drive model	① Compatible rotary servo motors		
		Cylindric type	Flat type	
② 1 phase 200 VAC	100 W	R88D-GT01H	R88M-G05030□ R88M-G10030□	R88M-GP10030□
	200 W	R88D-GT02H	R88M-G20030□	R88M-GP20030□
	400 W	R88D-GT04H	R88M-G40030□	R88M-GP40030□
	750 W	R88D-GT08H	R88M-G75030□	-
	1.0 kW	R88D-GT10H	R88M-G1K020T□	-
	1.5 kW	R88D-GT15H	R88M-G90010T□	-
			R88M-G1K030T□	-
			R88M-G1K520T□ R88M-G1K530T□	- -

Control cables (for CN1)

Symbol	Description	Connect to	Model	
⑤	Control cable (1 axis)	Motion control units CS1W-MC221 CS1W-MC421	1 m	R88A-CPG001M1
			2 m	R88A-CPG002M1
			3 m	R88A-CPG003M1
			5 m	R88A-CPG005M1
			5 m	R88A-CPG005M2
⑥	Control cable (line-driver output for 1 axis)	Position control units (high-speed type) CJ1W-NC234 CJ1W-NC434	1 m	XW2Z-100J-G9
			5 m	XW2Z-500J-G9
			10 m	XW2Z-10MJ-G9
			1 m	XW2Z-100J-G13
	Control cable (open-collector output for 1 axis)	Position control units (high-speed type) CJ1W-NC214 CJ1W-NC414	3 m	XW2Z-300J-G13
			1 m	XW2Z-100J-G1
	Control cable (line-driver output for 2 axis)	Position control units (high-speed type) CJ1W-NC234 CJ1W-NC434	5 m	XW2Z-500J-G1
			10 m	XW2Z-10MJ-G1
			1 m	XW2Z-100J-G5
	Control cable (open-collector output for 2 axis)	Position control units (high-speed type) CJ1W-NC214 CJ1W-NC414	3 m	XW2Z-300J-G5

Symbol	Description	Connect to	Model	
⑦	Terminal block cable for external signals (for input common, forward/reverse run prohibited inputs, emergency stop input, origin proximity input and interrupt input)	Position control units (high-speed type) CJ1W-NC234 CJ1W-NC434 CJ1W-NC214 CJ1W-NC414	0.5 m	XW2Z-C50X
			1 m	XW2Z-100X
			2 m	XW2Z-200X
			3 m	XW2Z-300X
			5 m	XW2Z-500X
			10 m	XW2Z-010X
⑧	Terminal block for external signals (M3 screw, pin terminals)		-	XW2B-20G4
	Terminal block for ext. signals (M3.5 screw, fork/round terminals)		-	XW2B-20G5
	Terminal block for ext. signals (M3 screw, fork/round terminals)		-	XW2D-20G6
⑨	Cable from servo relay unit to servo drive	CS1W-NC1□3, CJ1W-NC1□3, C200HW-NC113, CS1W-NC2□3/4□3, CJ1W-NC2□3/4□3, C200HW-NC213/413, CQM1H-PLB21 or CQM1-CPU43	1 m	XW2Z-100J-B25
			2 m	XW2Z-200J-B25
		CJ1M-CPU21/22/23	1 m	XW2Z-100J-B31
			2 m	XW2Z-200J-B31
⑩	Servo relay unit	Position control units CS1W-NC1□3, CJ1W-NC1□3 or C200HW-NC113	-	XW2B-20J6-1B (1 axis)
		Position control units CS1W-NC2□3/4□3, CJ1W-NC2□3/4□3 or C200HW-NC213/413	-	XW2B-40J6-2B (2 axes)
		CQM1H-PLB21 or CQM1-CPU43	-	XW2B-20J6-3B (1 axis)
		CJ1M-CPU21/22/23	-	XW2B-20J6-8A (1 axis) XW2B-40J6-9A (2 axes)
⑪	Position control unit connecting cable	CQM1H-PLB21 or CQM1-CPU43	0.5 m	XW2Z-050J-A3
			1 m	XW2Z-100J-A3
		CS1W-NC113 or C200HW-NC113	0.5 m	XW2Z-050J-A6
			1 m	XW2Z-100J-A6
		CS1W-NC213/413 or C200HW-NC213/413	0.5 m	XW2Z-050J-A7
			1 m	XW2Z-100J-A7
		CS1W-NC133	0.5 m	XW2Z-050J-A10
			1 m	XW2Z-100J-A10
		CS1W-NC233/433	0.5 m	XW2Z-050J-A11
			1 m	XW2Z-100J-A11
		CJ1W-NC113	0.5 m	XW2Z-050J-A14
			1 m	XW2Z-100J-A14
		CJ1W-NC213/413	0.5 m	XW2Z-050J-A15
			1 m	XW2Z-100J-A15
		CJ1W-NC133	0.5 m	XW2Z-050J-A18
			1 m	XW2Z-100J-A18
		CJ1W-NC233/433	0.5 m	XW2Z-050J-A19
	1 m	XW2Z-100J-A19		
CJ1M-CPU21/22/23	0.5 m	XW2Z-050J-A33		
	1 m	XW2Z-100J-A33		
⑫	General purpose cable	For general purpose controllers	1 m	R88A-CPG001S
			2 m	R88A-CPG002S
⑬	Terminal block cable	For general purpose controllers	1 m	XW2Z-100J-B24
			2 m	XW2Z-200J-B24
⑭	Terminal block (M3 screw and for pin terminals)		-	XW2B-50G4
	Terminal block (M3.5 screw and for fork/round terminals)		-	XW2B-50G5
	Terminal block (M3 screw and for fork/round terminals)		-	XW2D-50G6

Computer cable (for CN3)

Symbol	Name	Model
⑮	Computer cable RS232	2 m R88A-CCG002P2

Connectors

Specifications	Model
I/O connector kit, 50 pins (for CN1)	R88A-CNU11C

Filters

Symbol	Applicable servodrive	Filter model	Rated current	Leakage current	Rated voltage			
⑯	R88D-GT01H	R88A-FIK102-RE	2.4 A	3.5 mA	250 VAC single-phase			
	R88D-GT02H							
	R88D-GT04H					R88A-FIK104-RE	4.1 A	3.5 mA
	R88D-GT08H					R88A-FIK107-RE	6.6 A	3.5 mA
	R88D-GT10H					R88A-FIK114-RE	14.2 A	3.5 mA
	R88D-GT15H							

Computer software

Specifications	Model
Configuration and monitoring software tool for servo drives and inverters. (CX-drive version 1.70 or higher)	CX-drive
Complete OMRON software package including CX-drive. (CX-One version 3.10 or higher)	CX-One

External regenerative resistor

Symbol	Regenerative resistor unit model	Specifications
⑰	R88A-RR08050S	50 Ω, 80 W
	R88A-RR080100S	100 Ω, 80 W
	R88A-RR22047S	47 Ω, 220 W
	R88A-RR50020S	20 Ω, 500 W

ALL DIMENSIONS SHOWN ARE IN MILLIMETERS.
To convert millimeters into inches, multiply by 0.03937. To convert grams into ounces, multiply by 0.03527.

R7D-BP□, R88D-GP08H

SmartStep 2 servo drive

Another step forward in drive simplicity

- On-line Auto-tuning and Easy set up
- Ultra-compact size. The footprint is only 48% that of the SmartStep series
- Two torque limits
- Electronic gear, four internal speed settings and wide range of pulse settings
- Adaptive filters for suppression of vibration and resonance
- Configuration and commissioning using CX Drive-software

Ratings

- 230 VAC single-phase 50 W to 750 W (0.16 to 2.4 Nm)



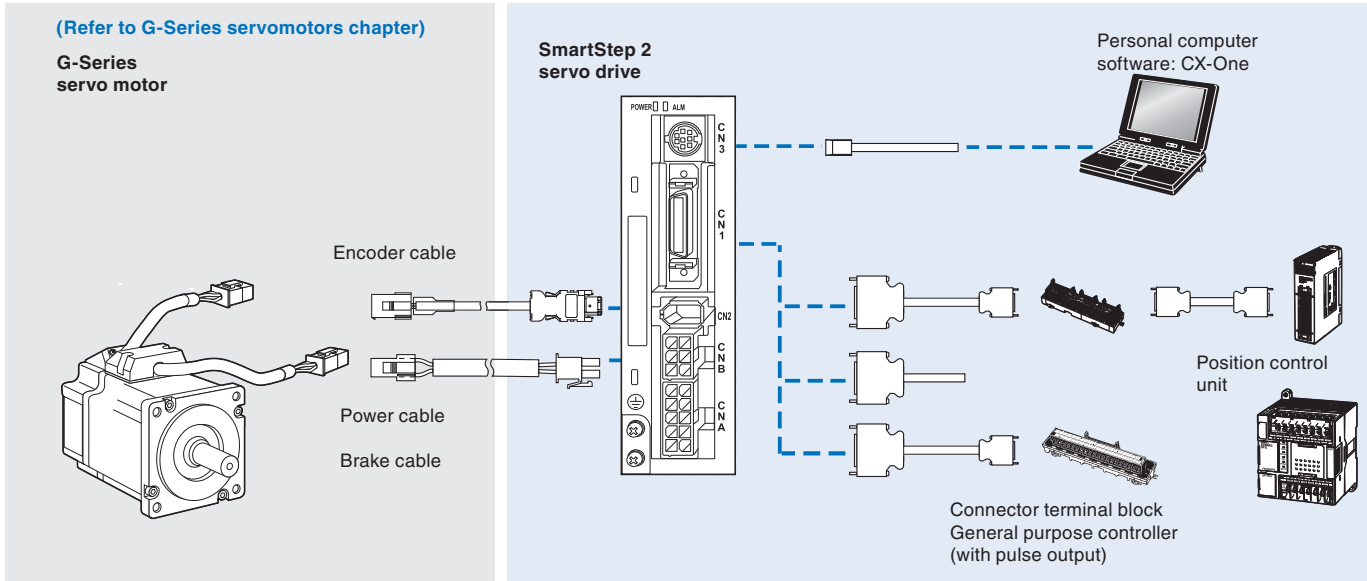

AC Servo systems

System configuration



Servo motor / servo drive combination

Servo motor							SmartStep2 servo drive	
Family	Power	Image	Voltage	Speed	Rated torque	Capacity	Model	
Cylindric	50 -750 W		230 V	3000 min ⁻¹	0.16 Nm	50 W	R88M-G05030H-□S2	R7D-BP01H
					0.32 Nm	100 W	R88M-G10030H-□S2	R7D-BP01H
					0.64 Nm	200 W	R88M-G20030H-□S2	R7D-BP02HH
					1.3 Nm	400 W	R88M-G40030H-□S2	R7D-BP04H
					2.4 Nm	750 W	R88M-G75030H-□S2	R88D-GP08H
Flat	100-400 W		230 V	3000 min ⁻¹	0.32 Nm	100 W	R88M-GP10030H-□S2	R7D-BP01H
					0.64 Nm	200 W	R88M-GP20030H-□S2	R7D-BP02HH
					1.3 Nm	400 W	R88M-GP40030H-□S2	R7D-BP04H

Servo drive type designation

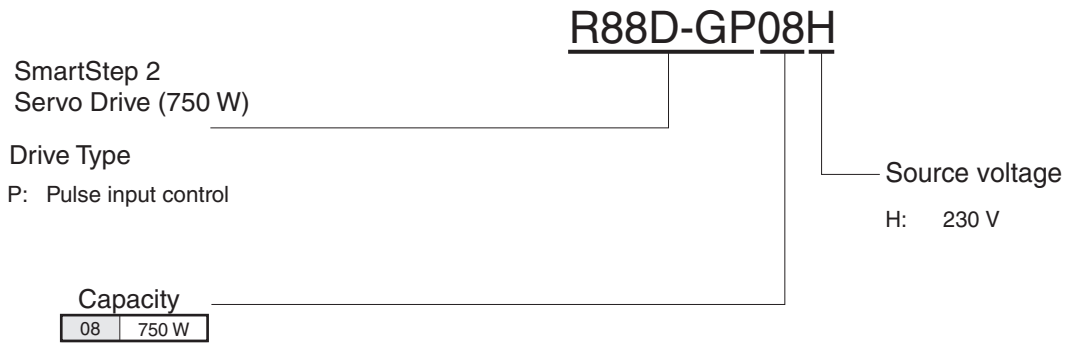
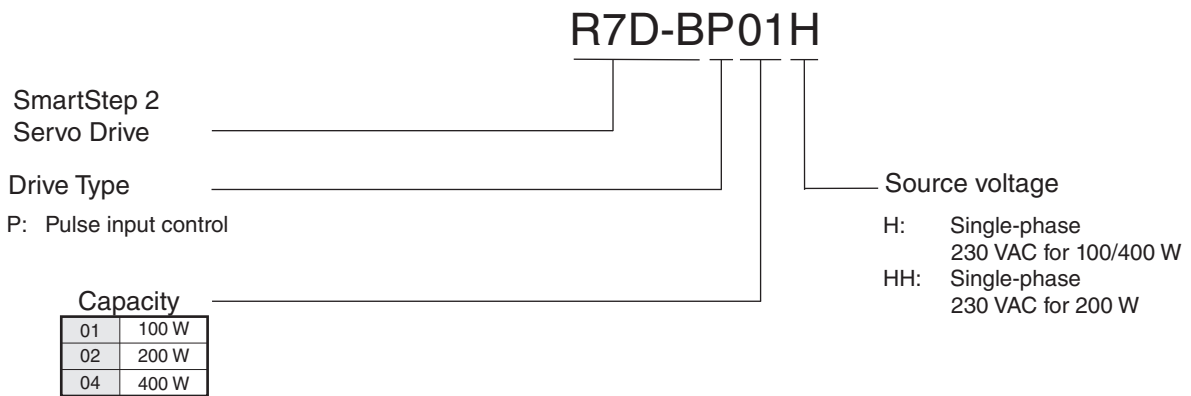

Servo drive specifications

General specifications

Item	Specification
Ambient operating temperature	0 to 55°C
Ambient operating humidity	90% max. (with no condensation)
Ambient storage temperature	-20 to 65°C
Ambient storage humidity	90% max. (with no condensation)
Storage/operating atmosphere	No corrosive gases.
Vibration resistance	10 to 60 Hz; acceleration : 5.9 m/s ² (0.6G) max.
Impact resistance	Acceleration 19.6 m/s ² max., 3 times each in X, Y, and Z directions.
Insulation resistance	Between power supply/power line terminals and frame ground: 0.5 MΩ min. (at 500 VDC)
Dielectric strength	Between power supply/power terminals and frame ground: 1,500 VAC for 1 min at 50/60 Hz Between each control signal and frame ground: 500 VAC for 1 min
Protective structure	Built into panel (IP10).
International standards	Approval obtained for UL: UL 508C; cUL: cUL C22.2 No 14 Approval EC : EMC EN55011 class A Group 1, EN 61000-6-2, low voltage EN50178

Performance specifications

Item	200 VAC input type			
	100 W R7D-BP01H	200 W R7D-BP02HH	400 W R7D-BP04H	750 W R88D-GP08H
Continuous output current (rms)	1.0 A	1.6 A	2.5 A	4 A
Momentary maximum output current (rms)	3.3 A	4.9 A	7.8 A	14.1 A
Main-circuit power supply	Single-phase 200 to 240 VAC (170 to 264 V), 50/60 Hz			Single-phase/three-phase 200 to 240 VAC (170 to 264 V), 50/60 Hz
Control circuit input power	-			Single-phase 200 to 240 VAC (170 to 264 V)
Control method	All-digital method			
Feedback	10,000 pulses/revolution incremental encoder			
Inverter method	PWM method based on IGBT			
PWM frequency	12 kHz		6 kHz	
Weight	0.35 kg	0.42 kg	0.42 kg	1.5 kg
Compatible motor voltage	200 V			
Command pulse response	Line drive: 500 kpps			
Compatible motor capacity	50 W 100 W	200 W	400 W	750 W
Applicable servo motor (R88M-)	G05030H G10030H GP10030H	G020030H GP20030H	G40030H GP40030H	G75030H

Servodrive part names

SmartStep2 Servo Drive (100 - 400 W models)

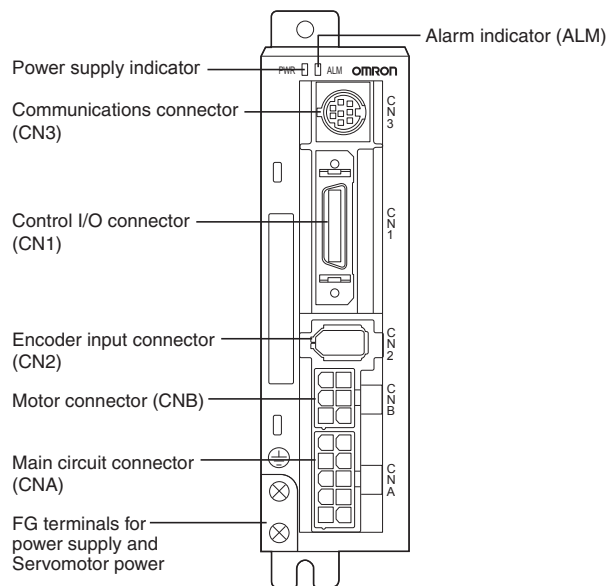

SmartStep2 Servo Drive (750 W model)

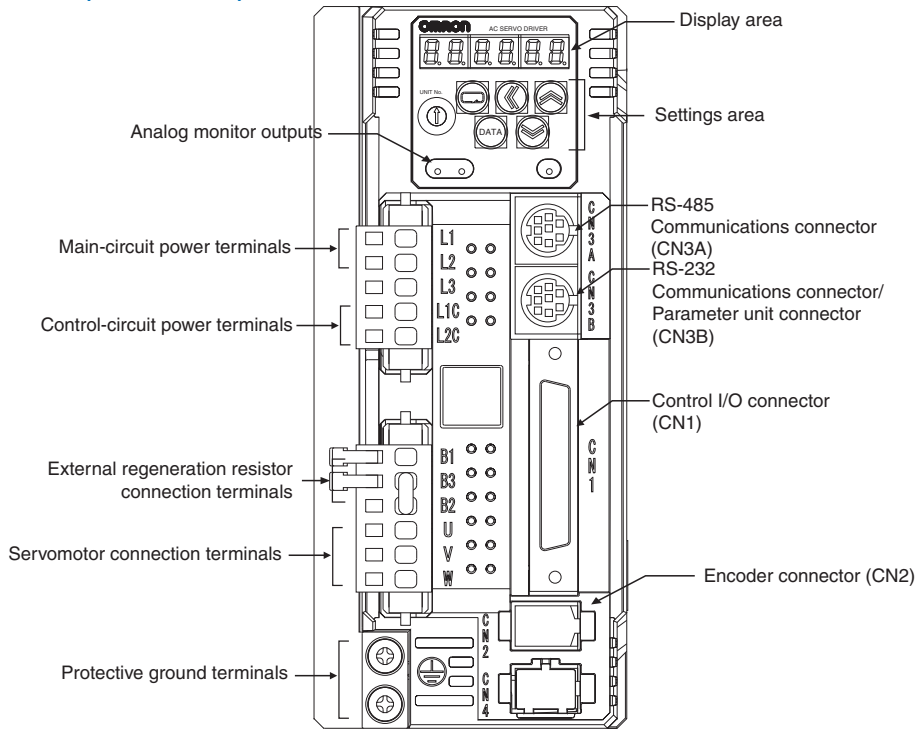

Dimensions

Servo drives

R7D-BP01H (230 V, 100 W)

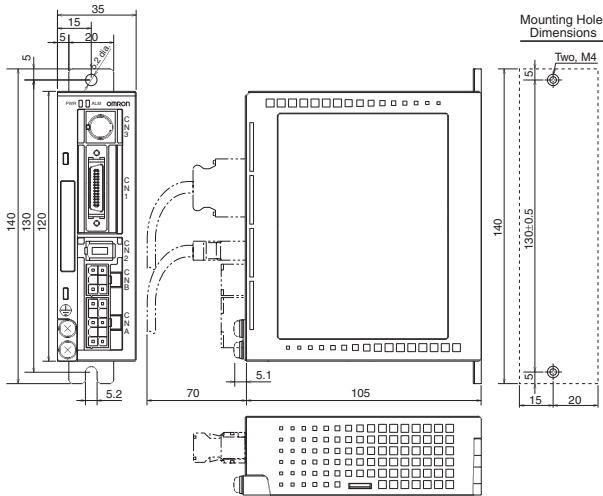

R7D-BP02HH/04H (230 V, 200-400 W)

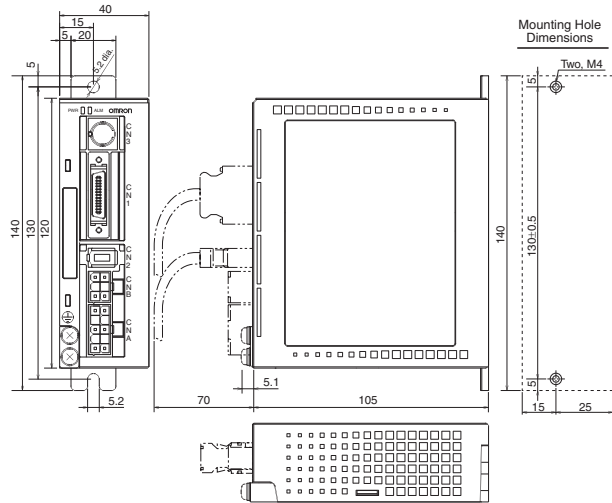

R88D-GP08H (230 V, 750 W)

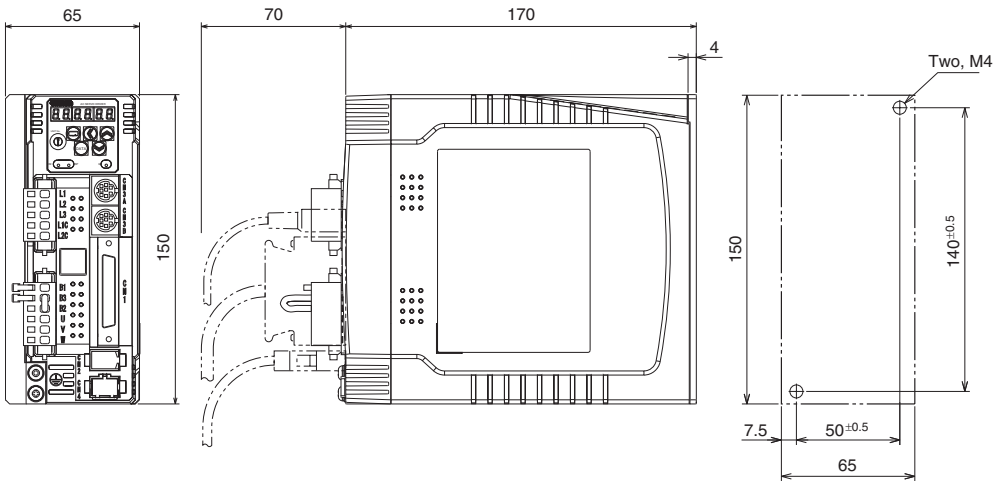

Filters

R7A-FIB104-RE

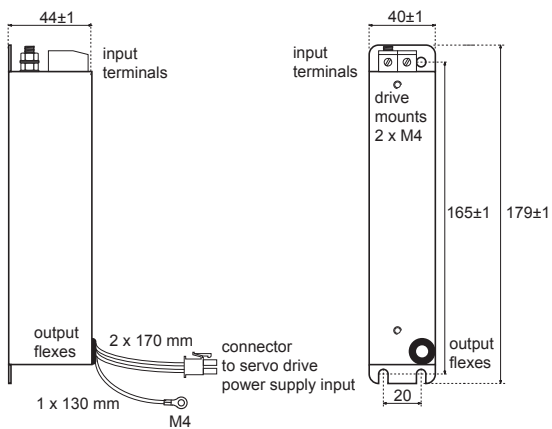

R88A-FIK107-RE

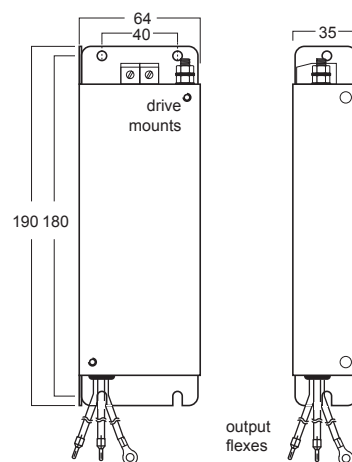

Filter model	Rated current	Leakage current	Rated voltage
R7A-FIB104-RE	4 A	3.5 mA	250 VAC single-phase
R88A-FIK107-RE	6.6 A	3.5 mA	250 VAC single-phase

Installation

Single-phase, 230 VAC

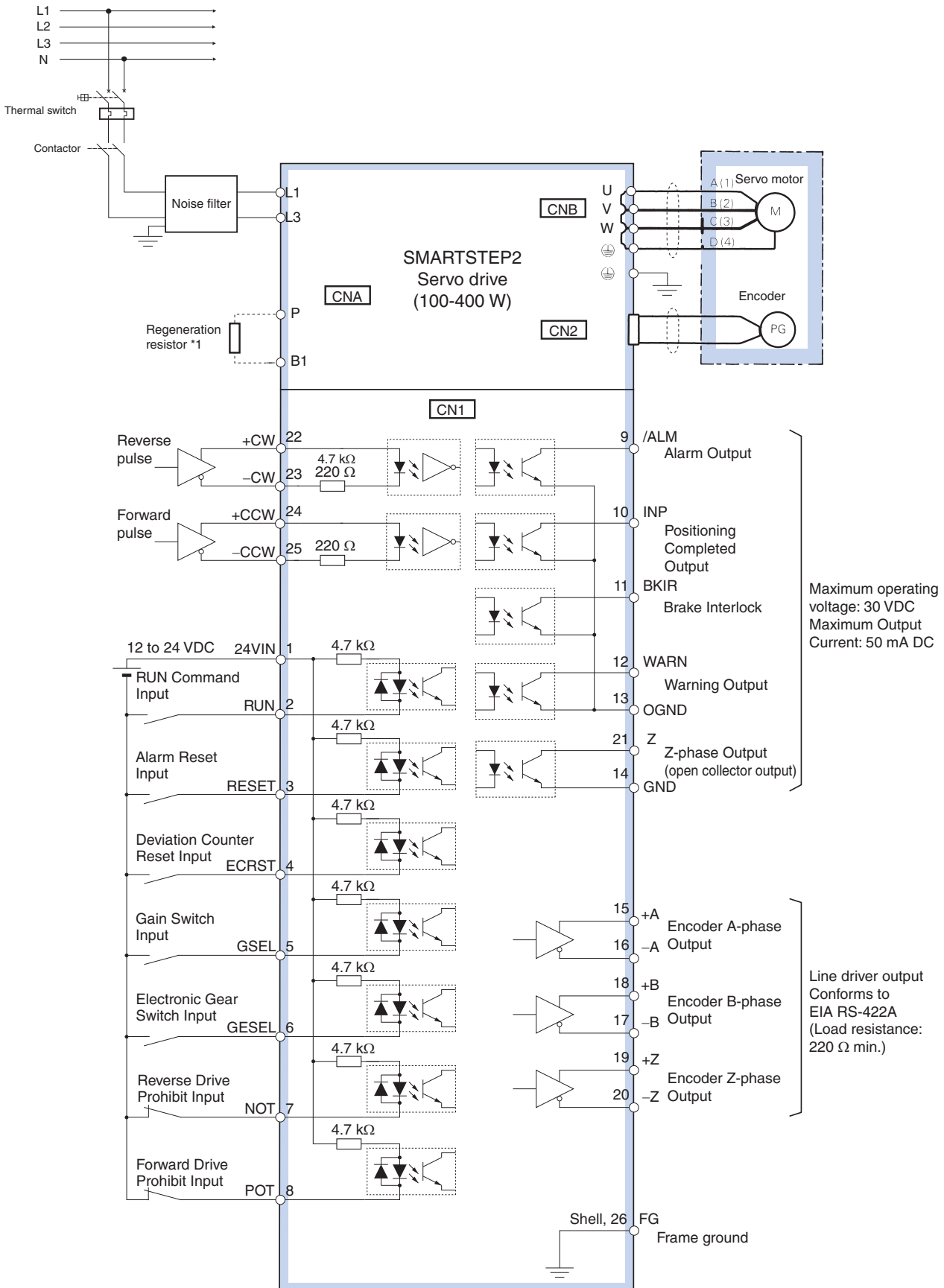

*1. An External Regeneration Resistor can be connected. Connect this resistor if the regenerative energy exceeds regeneration absorption capacity in the Servo Drive.

Note:1. The dynamic brake operates when the main circuit power supply or the control circuit power supply is turned OFF.

2. When turning OFF the main circuit power supply, turn OFF the RUN Command Input (RUN) signal at the same time.

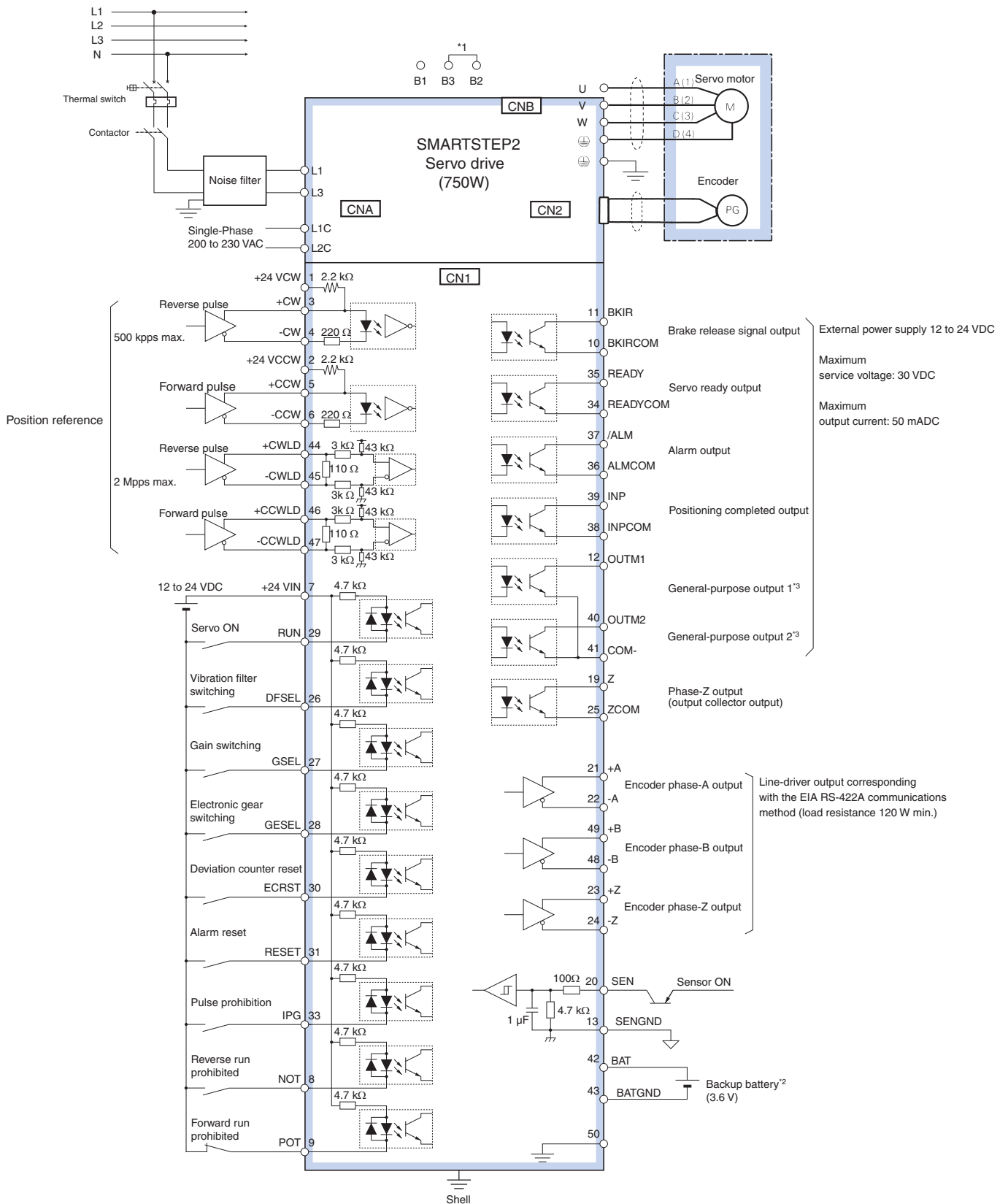

*1 B3-B2 are short-circuited. If the internal regenerative resistor is insufficient, remove the wire between B2 and B3 and connect an external regenerative resistor between B1 and B2.

*2 Use only when an absolute encoder. If a backup battery is connected, an encoder cable with a battery is not required.

*3 The default values are ZSP (zero-speed detection) for OUTM1 and T-LIMIT (at torque limit) for OUTM2.

Ordering information

SmartStep2 Servo Drive Configuration (100-400 W)

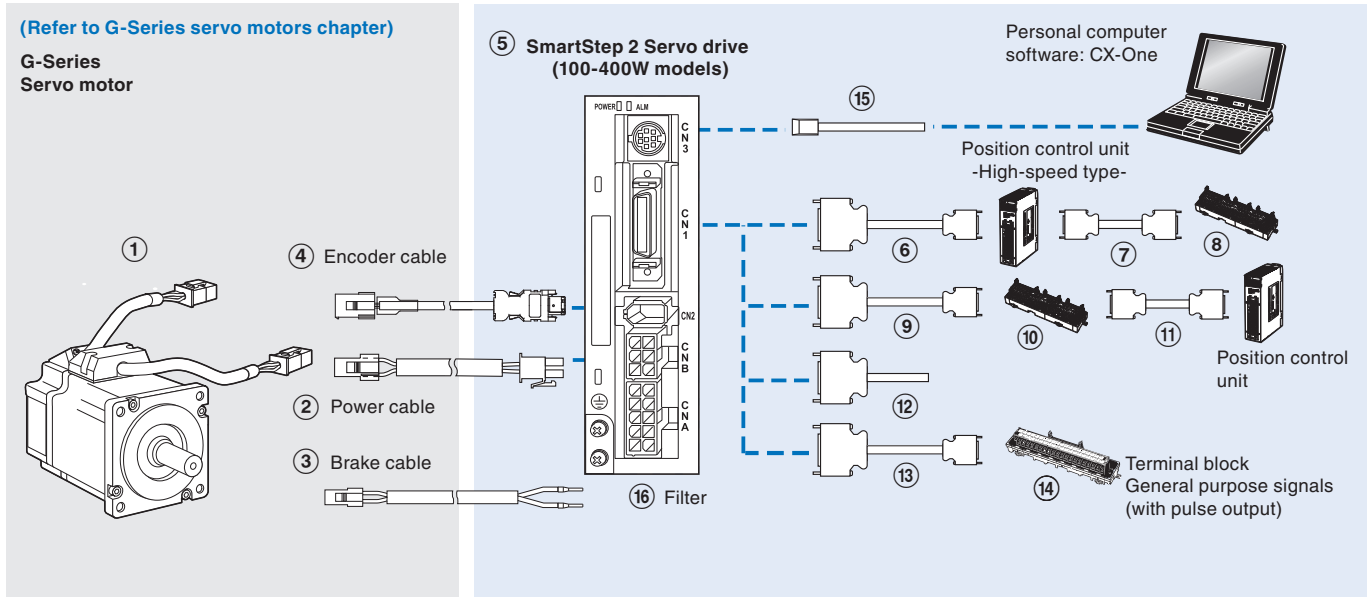

Note: The symbols ①②③④⑤... show the recommended sequence to select the components in a SmartStep 2 servo system

Servo motor

Note: ①②③④ refer to G-Series motor chapter for detailed motor specifications and selection.

Servo drives

Symbol	Specifications		SmartStep 2 drive model	Compatible servo motors ①	
				Cylindrical type	Flat type
⑤	200 VAC	100 W	R7D-BP01H	R88M-G05030H-□	-
		200 W	R7D-BP02HH	R88M-G10030H-□	R88M-GP10030H-□
		400 W	R7D-BP04H	R88M-G20030H-□	R88M-GP20030H-□
				R88M-G40030H-□	R88M-GP40030H-□

Power Supply cables (for CNA)

Symbol	Specifications	Model	Appearance
⑤	Power Supply Input Cable for Single-Phase Power (connectors attached)	R7A-CLB002S2	

Control cables (for CN1)

Symbol	Description	Connect to		Model
⑥	Control cable (line-driver output for 1 axis)	Position control unit (high-speed type) CJ1W-NC234 CJ1W-NC434	1 m	XW2Z-100J-G12
			5 m	XW2Z-500J-G12
			10 m	XW2Z-10MJ-G12
	Control cable (open-collector output for 1 axis)	Position control unit (high-speed type) CJ1W-NC214 CJ1W-NC414	1 m	XW2Z-100J-G16
			3 m	XW2Z-300J-G16
	Control cable (line-driver output for 2 axis)	Position control unit (high-speed type) CJ1W-NC234 CJ1W-NC434	1 m	XW2Z-100J-G4
			5 m	XW2Z-500J-G4
			10 m	XW2Z-10MJ-G4
	Control cable (open-collector output for 2 axis)	Position control unit (high-speed type) CJ1W-NC214 CJ1W-NC414	1 m	XW2Z-100J-G8
			3 m	XW2Z-300J-G8
⑦	Terminal block cable for external signals (for input common, forward/reverse run prohibited inputs, emergency stop input, origin proximity input and interrupt input)	Position control units (high-speed type) CJ1W-NC234 CJ1W-NC434 CJ1W-NC214 CJ1W-NC414	0.5 m	XW2Z-C50X
			1 m	XW2Z-100X
			2 m	XW2Z-200X
			3 m	XW2Z-300X
			5 m	XW2Z-500X
			10 m	XW2Z-010X
⑧	Terminal block for external signals (with M3 screw and for pin terminals)		-	XW2B-20G4
	Terminal block ext. signals (with M3.5 screw and for fork/round terminals)		-	XW2B-20G5
	Terminal block ext. signals (with M3 screw and fork/round pin terminals)		-	XW2D-20G6

Symbol	Description	Connect to		Model
⑨	Cable from servo relay unit to servo drive	CS1W-NC1□3, CJ1W-NC1□3, C200HW-NC113, CS1W-NC2□3/4□3, CJ1W-NC2□3/4□3, C200HW-NC213/413, CQM1H-PLB21 or CQM1-CPU43-V1	1 m	XW2Z-100J-B29
			2 m	XW2Z-200J-B29
		CJ1M-CPU21/22/23	1 m	XW2Z-100J-B32
			2 m	XW2Z-200J-B32
⑩	Servo relay unit	CS1W-NC1□3, CJ1W-NC1□3 or C200HW-NC113 position control unit	-	XW2B-20J6-1B (1 axis)
			-	XW2B-40J6-2B (2 axes)
		CS1W-NC2□3/4□3, CJ1W-NC2□3/4□3 or C200HW-NC213/413 position control unit	-	XW2B-20J6-3B (1 axis)
			-	XW2B-20J6-8A (1 axis)
		CJ1M-CPU21/22/23	-	XW2B-40J6-9A (2 axes)
⑪	Position control unit connecting cable	CJ1W-NC133	0.5 m	XW2Z-050J-A18
			1 m	XW2Z-100J-A18
		CJ1W-NC233/433	0.5 m	XW2Z-050J-A19
			1 m	XW2Z-100J-A19
		CS1W-NC133	0.5 m	XW2Z-050J-A10
			1 m	XW2Z-100J-A10
		CS1W-NC233/433	0.5 m	XW2Z-050J-A11
			1 m	XW2Z-100J-A11
		CJ1W-NC113	0.5 m	XW2Z-050J-A14
			1 m	XW2Z-100J-A14
		CJ1W-NC213/413	0.5 m	XW2Z-050J-A15
			1 m	XW2Z-100J-A15
		CS1W-NC113 C200HW-NC113	0.5 m	XW2Z-050J-A6
			1 m	XW2Z-100J-A6
		CS1W-NC213/413 C200HW-NC213/413	0.5 m	XW2Z-050J-A7
			1 m	XW2Z-100J-A7
		CJ1M-CPU21/22/23	0.5 m	XW2Z-050J-A33
			1 m	XW2Z-100J-A33
		CQM1H-PLB21 CQM1-CPU43-V1	0.5 m	XW2Z-050J-A3
			1 m	XW2Z-100J-A3
⑫	General purpose cable	For general purpose controllers	1 m	R7A-CPB001S
			2 m	R7A-CPB002S
⑬	Terminal block cable	For general purpose controllers	1 m	XW2Z-100J-B28
			2 m	XW2Z-200J-B28
⑭	Terminal block (with M3 screw and for pin terminals)	-	XW2B-34G4	
	Terminal block (with M3.5 screw and for fork/round terminals)	-	XW2B-34G5	
	Terminal block (with M3 screw and fork/round pin terminals)	-	XW2D-34G6	

Cable for CN3

Symbol	Name	Length	Model
⑮	Personal Computer Monitor Cable	2 m	R88A-CCG002P2

Filters

Symbol	Applicable servo drive	Rated current	Rated voltage	Filter model
⑯	R7D-BP01H/ 02HH/ 04H	4 A	1 pH, 230 V	R7A-FIB104-RE

Connectors

Specifications	Model
Main Circuit Connector (CNA)	R7A-CNB01P
Servomotor Connector (CNB)	R7A-CNB01A
Control I/O Connector (CN1)	R88A-CNW01C
Encoder Input Connector (CN2)	R88A-CNW01R
Servomotor Connector for Encoder Cable	R88A-CNG02R
Servomotor Connector for Servomotor Power Cable	R88A-CNG01A
Brake Cable Connector	R88A-CNG01B

External regeneration resistor cable

Specifications	Model
External Regenerative Resistor Connection Cable, 2 meters	R7A-CLB002RG

Parameter unit & computer software

Specifications	Model
Parameter copy unit (with cable)	R88A-PR02G
Configuration and monitoring software tool for servo drives and inverters. (CX-drive version 1.8 or higher)	CX-drive

External regeneration resistor

Specification	Model
80 W, 50 Ω	R88A-RR08050S
80 W, 100 Ω	R88A-RR080100S
220 W, 47 Ω	R88A-RR22047S

SmartStep2 Servo Drive Configuration (750W)

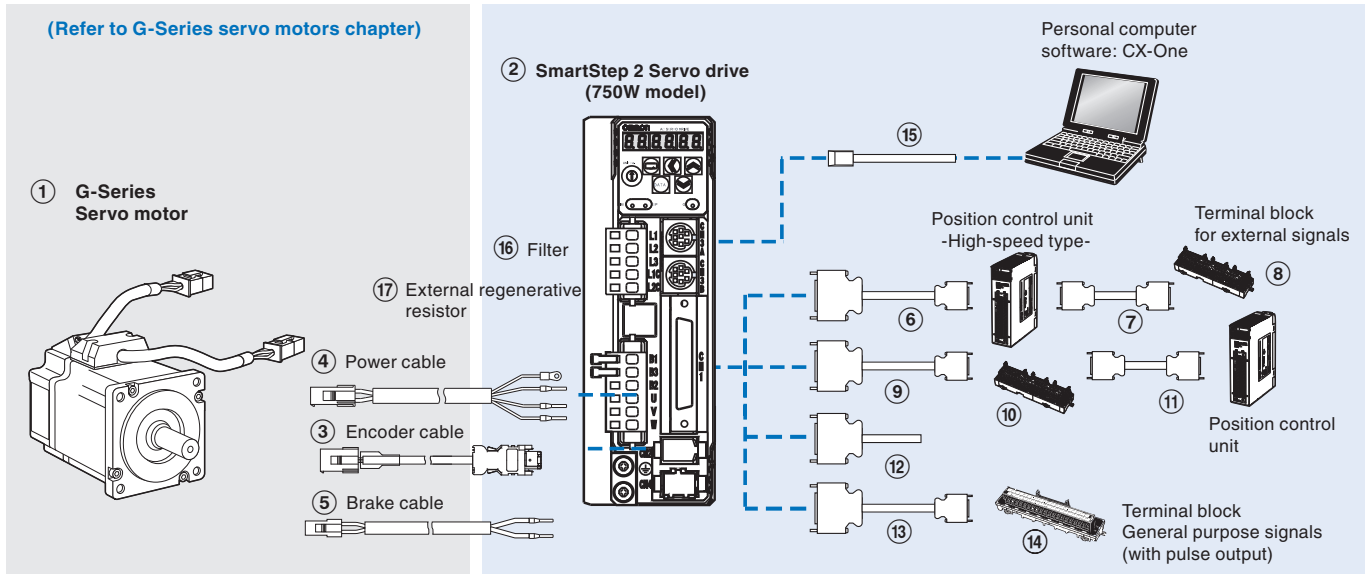

Note: The symbols ①②③④⑤... show the recommended sequence to select the components in a SmartStep 2 servo system.

Servo motor

Note: ①③④⑤ refer to G-Series motor chapter for detailed motor specifications and selection.

Servo drives

Symbol	Specifications	Servo drive model	① Compatible rotary servo motors
②	1 phase 200 VAC 750 W	R88D-GP08H	Cylindric type R88M-G75030H-□

Control cables (for CN1)

Symbol	Description	Connect to	Model		
⑥	Control cable (line-driver output for 1 axis)	Position control units (high-speed type) CJ1W-NC234 CJ1W-NC434	1 m XW2Z-100J-G9 5 m XW2Z-500J-G9 10 m XW2Z-10MJ-G9		
	Control cable (open-collector output for 1 axis)	Position control units (high-speed type) CJ1W-NC214 CJ1W-NC414	1 m XW2Z-100J-G13 3 m XW2Z-300J-G13		
	Control cable (line-driver output for 2 axis)	Position control units (high-speed type) CJ1W-NC234 CJ1W-NC434	1 m XW2Z-100J-G1 5 m XW2Z-500J-G1 10 m XW2Z-10MJ-G1		
	Control cable (open-collector output for 2 axis)	Position control units (high-speed type) CJ1W-NC214 CJ1W-NC414	1 m XW2Z-100J-G5 3 m XW2Z-300J-G5		
⑦	Terminal block cable for external signals (for input common, forward/reverse run prohibited inputs, emergency stop input, origin proximity input and interrupt input)	Position control units (high-speed type) CJ1W-NC234 CJ1W-NC434 CJ1W-NC214 CJ1W-NC414	0.5 m XW2Z-C50X		
			1 m XW2Z-100X		
			2 m XW2Z-200X		
			3 m XW2Z-300X		
			5 m XW2Z-500X		
			10 m XW2Z-010X		
⑧	Terminal block for external signals (M3 screw, pin terminals)	-	XW2B-20G4		
	Terminal block ext. signals(M3.5 screw, fork/round terminals)	-	XW2B-20G5		
	Terminal block ext. signals(M3 screw, fork/round terminals)	-	XW2D-20G6		
⑨	Cable from servo relay unit to servo drive	CS1W-NC1□3, CJ1W-NC1□3, C200HW-NC113/213/413, CS1W-NC2□3/4□3, CJ1W-NC2□3/4□3 or CQM1H-PLB21	1 m XW2Z-100J-B25 2 m XW2Z-200J-B25		
		CJ1M-CPU21/22/23	1 m XW2Z-100J-B31 2 m XW2Z-200J-B31		
		⑩	Servo relay unit	CS1W-NC1□3, CJ1W-NC1□3 or C200HW-NC113 position control unit	- XW2B-20J6-1B (1 axis)
				CS1W-NC2□3/4□3, CJ1W-NC2□3/4□3 or C200HW-NC213/413 position control unit	- XW2B-40J6-2B (2 axes)
⑩	Servo relay unit	CQM1H-PLB21	- XW2B-20J6-3B (1 axis)		
		CJ1M-CPU21/22/23	- XW2B-20J6-8A (1 axis) - XW2B-40J6-9A (2 axes)		

Symbol	Description	Connect to	Model	
⑪	Position control unit connecting cable	CQM1H-PLB21	0.5 m	XW2Z-050J-A3
			1 m	XW2Z-100J-A3
		CS1W-NC113 or C200HW-NC113	0.5 m	XW2Z-050J-A6
			1 m	XW2Z-100J-A6
		CS1W-NC213/413 or C200HW-NC213/413	0.5 m	XW2Z-050J-A7
			1 m	XW2Z-100J-A7
		CS1W-NC133	0.5 m	XW2Z-050J-A10
			1 m	XW2Z-100J-A10
		CS1W-NC233/433	0.5 m	XW2Z-050J-A11
			1 m	XW2Z-100J-A11
		CJ1W-NC113	0.5 m	XW2Z-050J-A14
			1 m	XW2Z-100J-A14
		CJ1W-NC213/413	0.5 m	XW2Z-050J-A15
			1 m	XW2Z-100J-A15
CJ1W-NC133	0.5 m	XW2Z-050J-A18		
	1 m	XW2Z-100J-A18		
CJ1W-NC233/433	0.5 m	XW2Z-050J-A19		
	1 m	XW2Z-100J-A19		
CJ1M-CPU21/22/23	0.5 m	XW2Z-050J-A33		
	1 m	XW2Z-100J-A33		
⑫	General purpose cable	For general purpose controllers	1 m	R88A-CPG001S
			2 m	R88A-CPG002S
⑬	Terminal block cable	For general purpose controllers	1 m	XW2Z-100J-B24
			2 m	XW2Z-200J-B24
⑭	Terminal block (M3 screw and for pin terminals)	-	XW2B-50G4	
	Terminal block (M3.5 screw and for fork/round terminals)	-	XW2B-50G5	
	Terminal block (M3 screw and for fork/round terminals)	-	XW2D-50G6	

Computer cable (for CN3)

Symbol	Name		Model
⑮	Computer cable RS232	2 m	R88A-CCG002P2

Filter

Symbol	Applicable servodrive	Filter model	Rated current	Leakage current	Rated voltage
⑯	R88D-GP08H	R88A-FIK107-RE	6.6 A	3.5 mA	250 VAC single-phase

External regenerative resistor

Symbol	Regenerative resistor unit model	Specifications
⑰	R88A-RR08050S	50 Ω, 80 W
	R88A-RR080100S	100 Ω, 80 W
	R88A-RR22047S	47 Ω, 220 W
	R88A-RR50020S	20 Ω, 500 W

Connectors

Specifications	Model
I/O connector kit -50 pins- (for CN1)	R88A-CNU11C
Power cable connector (motor side)	R88A-CNG01A
Encoder connector (Servo drive side CN2)	R88A-CNW01R
Incremental encoder cable connector (motor side)	R88A-CNG02R

Computer software

Specifications	Model
Configuration and monitoring software tool for servo drives and inverters (CX-drive version 1.91 or higher).	CX-Drive

ALL DIMENSIONS SHOWN ARE IN MILLIMETERS.
To convert millimeters into inches, multiply by 0.03937. To convert grams into ounces, multiply by 0.03527.

R88M-K□

Accurax G5 servo motors

**Servo family for accurate motion control.
Power range extended up to 15 kW.**

- Peak torque 300% of rated torque during 3 seconds or more depending on model
- High resolution serial encoder provided by 20 bits encoder
- IP67 protection in all models
- Ultra-light and compact size motor
- Low speed ripple and low torque ripple due to low torque cogging
- Various shaft, brake and seal options

Ratings

- 230 VAC from 50 W to 1.5 kW (rated torque from 0.16 to 8.59 Nm)
- 400 VAC from 400 W to 15 kW (rated torque from 1.91 Nm to 95.5 Nm)



AC Servo systems

System configuration

(Refer to servo drive chapter)

Servo drive options

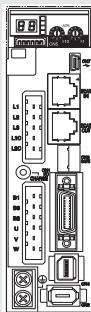

Accurax G5 servo drives
EtherCAT, ML2 and
Analogue/Pulse models

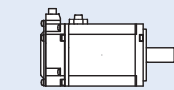
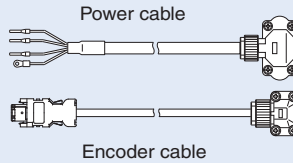

Servo motor
3000 rpm (50 W-750 W)

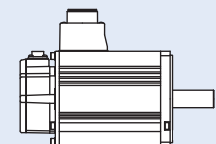
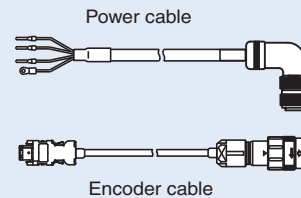



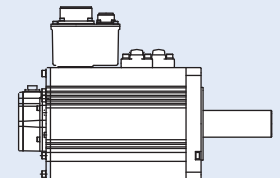

Servo motor
3000 rpm (750 W-5 kW)
2000 rpm (400 W-5 kW)
1000 rpm (900 W-3 kW)



Servo motor
1500 rpm (7.5 kW-15 kW)
1000 rpm (4.5 kW-6 kW)

Servo motor / servo drive combination

Accurax G5 rotary servo motor					Accurax G5 servo drive models			
	Voltage	Speed	Rated torque	Capacity	Model	EtherCAT	Analog/Pulse	MECHATROLINK-II
	230 V	3000 min ⁻¹	0.16 Nm	50 W	R88M-K05030(H/T)-□	R88D-KN01H-ECT	R88D-KT01H	R88D-KN01H-ML2
			0.32 Nm	100 W	R88M-K10030(H/T)-□	R88D-KN01H-ECT	R88D-KT01H	R88D-KN01H-ML2
			0.64 Nm	200 W	R88M-K20030(H/T)-□	R88D-KN02H-ECT	R88D-KT02H	R88D-KN02H-ML2
			1.3 Nm	400 W	R88M-K40030(H/T)-□	R88D-KN04H-ECT	R88D-KT04H	R88D-KN04H-ML2
			2.4 Nm	750 W	R88M-K75030(H/T)-□	R88D-KN08H-ECT	R88D-KT08H	R88D-KN08H-ML2
	400 V	3000 min ⁻¹	3.18 Nm	1000 W	R88M-K1K030(H/T)-□	R88D-KN15H-ECT	R88D-KT15H	R88D-KN15H-ML2
			4.77 Nm	1500 W	R88M-K1K530(H/T)-□	R88D-KN15H-ECT	R88D-KT15H	R88D-KN15H-ML2
			2.39 Nm	750 W	R88M-K75030(F/C)-□	R88D-KN10F-ECT	R88D-KT10F	R88D-KN10F-ML2
			3.18 Nm	1000 W	R88M-K1K030(F/C)-□	R88D-KN15F-ECT	R88D-KT15F	R88D-KN15F-ML2
			4.77 Nm	1500 W	R88M-K1K530(F/C)-□	R88D-KN15F-ECT	R88D-KT15F	R88D-KN15F-ML2
			6.37 Nm	2000 W	R88M-K2K030(F/C)-□	R88D-KN20F-ECT	R88D-KT20F	R88D-KN20F-ML2
			9.55 Nm	3000 W	R88M-K3K030(F/C)-□	R88D-KN30F-ECT	R88D-KT30F	R88D-KN30F-ML2
			12.7 Nm	4000 W	R88M-K4K030(F/C)-□	R88D-KN50F-ECT	R88D-KT50F	R88D-KN50F-ML2
			15.9 Nm	5000 W	R88M-K5K030(F/C)-□	R88D-KN50F-ECT	R88D-KT50F	R88D-KN50F-ML2
				230 V	2000 min ⁻¹	4.77 Nm	1000 W	R88M-K1K020(H/T)-□
7.16 Nm	1500 W	R88M-K1K520(H/T)-□				R88D-KN15H-ECT	R88D-KT15H	R88D-KN15H-ML2
1.91 Nm	400 W	R88M-K40020(F/C)-□				R88D-KN06F-ECT	R88D-KT06F	R88D-KN06F-ML2
2.86 Nm	600 W	R88M-K60020(F/C)-□				R88D-KN06F-ECT	R88D-KT06F	R88D-KN06F-ML2
4.77 Nm	1000 W	R88M-K1K020(F/C)-□				R88D-KN10F-ECT	R88D-KT10F	R88D-KN10F-ML2
400 V	2000 min ⁻¹	7.16 Nm		1500 W	R88M-K1K520(F/C)-□	R88D-KN15F-ECT	R88D-KT15F	R88D-KN15F-ML2
		9.55 Nm		2000 W	R88M-K2K020(F/C)-□	R88D-KN20F-ECT	R88D-KT20F	R88D-KN20F-ML2
		14.3 Nm		3000 W	R88M-K3K020(F/C)-□	R88D-KN30F-ECT	R88D-KT30F	R88D-KN30F-ML2
		19.1 Nm		4000 W	R88M-K4K020(F/C)-□	R88D-KN50F-ECT	R88D-KT50F	R88D-KN50F-ML2
		23.9 Nm		5000 W	R88M-K5K020(F/C)-□	R88D-KN50F-ECT	R88D-KT50F	R88D-KN50F-ML2
400 V	1500 min ⁻¹	47.8 Nm		7500 W	R88M-K7K515C-□	R88D-KN75F-ECT	R88D-KT75F	-
		70.0 Nm		11000 W	R88M-K11K015C-□	R88D-KN150F-ECT	R88D-KT150F	-
		95.5 Nm		15000 W	R88M-K15K015C-□	R88D-KN150F-ECT	R88D-KT150F	-
		8.59 Nm		900 W	R88M-K90010(H/T)-□	R88D-KN15H-ECT	R88D-KT15H	R88D-KN15H-ML2
		8.59 Nm		900 W	R88M-K90010(F/C)-□	R88D-KN15F-ECT	R88D-KT15F	R88D-KN15F-ML2
	230 V	1000 min ⁻¹	19.1 Nm	2000 W	R88M-K2K010(F/C)-□	R88D-KN30F-ECT	R88D-KT30F	R88D-KN30F-ML2
			28.7 Nm	3000 W	R88M-K3K010(F/C)-□	R88D-KN50F-ECT	R88D-KT50F	R88D-KN50F-ML2
			43.0 Nm	4500 W	R88M-K4K510C-□	R88D-KN50F-ECT	R88D-KT50F	R88D-KN50F-ML2
			57.3 Nm	6000 W	R88M-K6K010C-□	R88D-KN75F-ECT	R88D-KT75F	-
			400 V	1000 min ⁻¹	8.59 Nm	900 W	R88M-K90010(H/T)-□	R88D-KN15H-ECT
8.59 Nm	900 W	R88M-K90010(F/C)-□	R88D-KN15F-ECT		R88D-KT15F	R88D-KN15F-ML2		
19.1 Nm	2000 W	R88M-K2K010(F/C)-□	R88D-KN30F-ECT		R88D-KT30F	R88D-KN30F-ML2		
28.7 Nm	3000 W	R88M-K3K010(F/C)-□	R88D-KN50F-ECT		R88D-KT50F	R88D-KN50F-ML2		
43.0 Nm	4500 W	R88M-K4K510C-□	R88D-KN50F-ECT		R88D-KT50F	R88D-KN50F-ML2		

Note: 1. For servo motor and cables part numbers refer to ordering information at the end of this chapter
 2. Refer to the servo drive chapter for drive options selection and detailed specifications

Servo motor type designation

Servo motor

R88M-K05030H-BOS2

Accurax G5 Series Servomotor

Capacity

050	50 W
100	100 W
200	200 W
400	400 W
600	600 W
750	750 W
900	900 W
1K0	1 kW
1K5	1.5 kW
2K0	2 kW
3K0	3 kW
4K0	4 kW
4K5	4.5 kW
5K0	5 kW
6K0	6 kW
7K5	7.5 kW
11K0	11 kW
15K0	15 kW

Rated Speed (r/min)

10	1000
15	1500
20	2000
30	3000

Shaft end specifications

Blank	Straight shaft, no key
S2	Straight, key, tapped (standard)

Oil seal specifications

Blank	No oil seal
O	Oil seal

Brake specifications

Blank	No brake
B	Brake

Voltage and encoder specifications

H: 230 V and 20-bit incremental encoder
 T: 230 V and 17-bit absolute encoder
 F: 400 V and 20-bit incremental encoder
 C: 400 V and 17-bit absolute encoder

Servo motor specifications

Servo motors 3000 r/min, 230 V

Ratings and specifications

Voltage		230 V							
Servo motor model R88M-K□	20-bit incremental encoder	05030H-□	10030H-□	20030H-□	40030H-□	75030H-□	1K030H-□	1K530H-□	
	17-bit absolute encoder	05030T-□	10030T-□	20030T-□	40030T-□	75030T-□	1K030T-□	1K530T-□	
Rated output	W	50	100	200	400	750	1000	1500	
Rated torque	N·m	0.16	0.32	0.64	1.3	2.4	3.18	4.77	
Instantaneous peak torque	N·m	0.48	0.95	1.91	3.8	7.1	9.55	14.3	
Rated current	A (rms)	1.1	1.1	1.5	2.4	4.1	6.6	8.2	
Instantaneous max. current	A (rms)	4.7	4.7	6.5	10.2	17.4	28	35	
Rated speed	min ⁻¹	3000							
Max. speed	min ⁻¹	6000				5000			
Torque constant	N·m/A	0.11±10%	0.21±10%	0.31±10%	0.39±10%	0.42±10%	0.37	0.45	
Rotor moment of inertia (JM)	kg·m ² ×10 ⁻⁴ (without brake)	0.025	0.051	0.14	0.26	0.87	2.03	2.84	
	kg·m ² ×10 ⁻⁴ (with brake)	0.027	0.054	0.16	0.28	0.97	2.35	3.17	
Allowable load moment of inertia (JL)	Multiple of (JM)	30				20	15		
Rated power rate	kW/s (without brake)	10.1	19.9	29.0	62.4	65.6	49.8	80.1	
	kW/s (with brake)	9.4	18.8	25.4	58	58.8	43	71.8	
Allowable radial load	N	68		245		490			
Allowable thrust load	N	58		98		196			
Approx. mass	Kg (without brake)	0.32	0.47	0.82	1.2	2.3	3.5	4.4	
	Kg (with brake)	0.53	0.68	1.3	1.7	3.1	4.5	5.4	
Brake specifications	Rated voltage	24VDC ±10%							
	Holding brake moment of inertia J	kg·m ² ×10 ⁻⁴	0.002		0.0018		0.33		
	Power consumption (at 20°C)	W	7		9		17	19	
	Current consumption (at 20°C)	A	0.3		0.36		0.70±10%	0.81±10%	
	Static friction torque	N·m (minimum)	0.29		1.27		2.5	7.8	
Basic specifications	Rise time for holding torque	ms (max.)	35		50		50		
	Release time	ms (max)	20		15		15		
Basic specifications	Time Rating	Continuous							
	Insulation class	Type B						Type F	
	Ambient operating/ storage temperature	0 to +40°C/ -20 to 65°C							
	Ambient operating/ storage humidity	20 to 80% (non-condensing)						20 to 85% (non-condensing)	
	Vibration class	V-15							
	Insulation resistance	20 MΩ min. at 500 VDC between the power terminals and FG terminal							
	Enclosure	Totally-enclosed, self-cooling, IP67 (excluding shaft opening)							
	Mounting	Flange-mounted							

Torque-speed characteristics

R88M-K05030H/T (50 W)

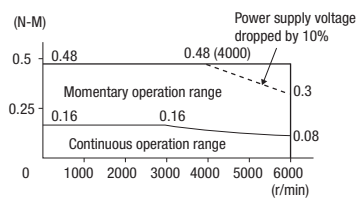

R88M-K10030H/T (100 W)

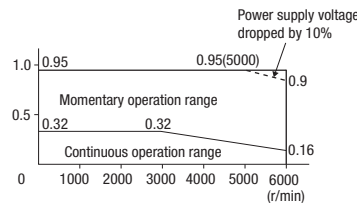

R88M-K20030H/T (200 W)

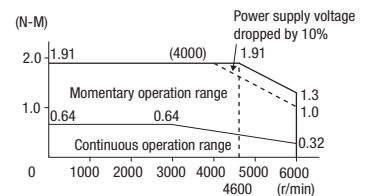

R88M-K40030H/T (400 W)

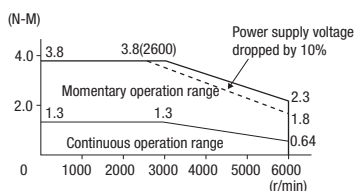

R88M-K75030H/T (750 W)

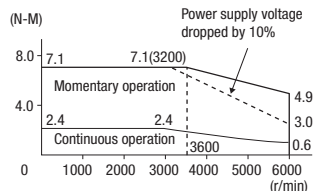

R88M-K1K030H/T (1 kW)

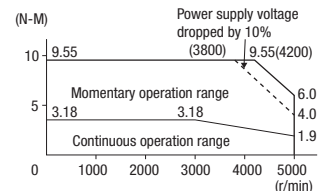

R88M-K1K530H/T (1.5 kW)

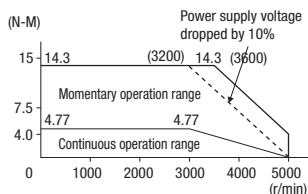

Servo motors 3000 r/min, 400 V

Ratings and specifications

Voltage		400 V							
Servo motor model R88M-K□	20-bit incremental encoder	75030F-□	1K030F-□	1K530F-□	2K030F-□	3K030F-□	4K030F-□	5K030F-□	
	17-bit absolute encoder	75030C-□	1K030C-□	1K530C-□	2K030C-□	3K030C-□	4K030C-□	5K030C-□	
Rated output	W	750	1000	1500	2000	3000	4000	5000	
Rated torque	N·m	2.39	3.18	4.77	6.37	9.55	12.7	15.9	
Instantaneous peak torque	N·m	7.16	9.55	14.3	19.1	28.6	38.2	47.7	
Rated current	A (rms)	2.4	3.3	4.2	5.7	9.2	9.9	12	
Instantaneous max. current	A (rms)	10	14	18	24	39	42	51	
Rated speed	min ⁻¹	3000							
Max. speed	min ⁻¹	5000					4500		
Torque constant	N·m/A	0.78	0.75	0.89	0.87	0.81	0.98		
Rotor moment of inertia (JM)	kg·m ² ×10 ⁻⁴ (without brake)	1.61	2.03	2.84	3.68	6.5	12.9	17.4	
	kg·m ² ×10 ⁻⁴ (with brake)	1.93	2.35	3.17	4.01	7.85	14.2	18.6	
Allowable load moment of inertia (JL)	Multiple of (JM)	20		15					
Rated power rate	kW/s (without brake)	35.5	49.8	80.1	110	140	126	146	
	kW/s (with brake)	29.6	43	71.8	101	116	114	136	
Allowable radial load	N	490					784		
Allowable thrust load	N	196					343		
Approx. mass	Kg (without brake)	3.1	3.5	4.4	5.3	8.3	11	14	
	Kg (with brake)	4.1	4.5	5.4	6.3	9.4	12.6	16	
Brake specifications	Rated voltage	24VDC±10%							
	Holding brake moment of inertia J	kg·m ² ×10 ⁻⁴					0.33		1.35
	Power consumption (at 20°C)	W	17	19			22		
	Current consumption (at 20°C)	A	0.70±10%		0.81±10%			0.90±10%	
	Static friction torque	N·m (minimum)	2.5	7.8			11.8	16.1	
	Release time	ms (max)	50			110			
Basic specifications	Time Rating	Continuous							
	Insulation class	Type F							
	Ambient operating/ storage temperature	0 to +40°C/ -20 to 65°C							
	Ambient operating/ storage humidity	20% to 85% (non-condensing)							
	Vibration class	V-15							
	Insulation resistance	20 MΩ min. at 500 VDC between the power terminals and FG terminal							
	Enclosure	Totally-enclosed, self-cooling, IP67(excluding shaft opening)							
	Vibration resistance	Vibration acceleration 49 m/s ²							
Mounting	Flange-mounted								

Torque-speed characteristics

R88M-K75030F/C (750 W)

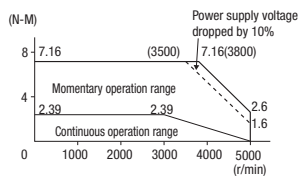

R88M-K1K030F/C (1 kW)

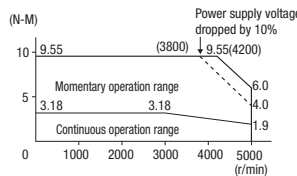

R88M-K1K530F/C (1.5 kW)

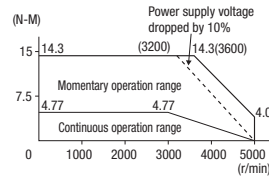

R88M-K2K030F/C (2 kW)

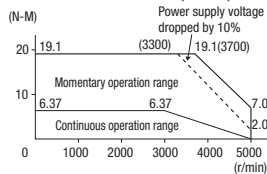

R88M-K3K030F/C (3 kW)

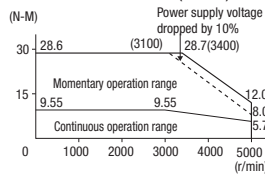

R88M-K4K030F/C (4 kW)

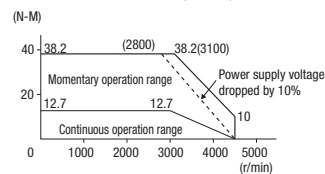

R88M-K5K030F/C (5 kW)

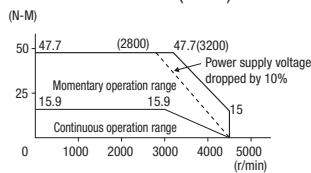

Servo motors 2000 r/min, 230V/ 400 V

Ratings and specifications

Voltage		230 V				400 V											
Servo motor model R88M-K□	20-bit incremental encoder	1K020H-□	1K520H-□	40020F-□	60020F-□	1K020F-□	1K520F-□	2K020F-□	3K020F-□	4K020F-□	5K020F-□						
	17-bit absolute encoder	1K020T-□	1K520T-□	40020C-□	60020C-□	1K020C-□	1K520C-□	2K020C-□	3K020C-□	4K020C-□	5K020C-□						
Rated output	W	1000	1500	400	600	1000	1500	2000	3000	4000	5000						
Rated torque	N·m	4.77	7.16	1.91	2.86	4.77	7.16	9.55	14.3	19.1	23.9						
Instantaneous peak torque	N·m	14.3	21.5	5.73	8.59	14.3	21.5	28.7	43	57.3	71.6						
Rated current	A (rms)	5.7	9.4	1.2	1.5	2.8	4.7	5.9	8.7	10.6	13						
Instantaneous max. current	A (rms)	24	40	4.9	6.5	12	20	25	37	45	55						
Rated speed	min ⁻¹	2000															
Max. speed	min ⁻¹	3000															
Torque constant	N·m/A	0.63	0.58	1.27	1.38	1.27	1.16	1.27	1.18	1.40	1.46						
Rotor moment of inertia (JM)	kg·m ² ×10 ⁻⁴ (without brake)	4.60	6.70	1.61	2.03	4.60	6.70	8.72	12.9	37.6	48						
	kg·m ² ×10 ⁻⁴ (with brake)	5.90	7.99	1.90	2.35	5.90	7.99	10	14.2	38.6	48.8						
Max. load moment of inertia (JL)	Multiple of (JM)	10															
Rated power rate	kW/s (without brake)	49.5	76.5	22.7	40.3	49.5	76.5	105	159	97.1	119						
	kW/s (with brake)	38.6	64.2	19.2	34.8	38.6	64.2	91.2	144	94.5	117						
Allowable radial load	N	490						784									
Allowable thrust load	N	196						343									
Approx. mass	kg (without brake)	5.2	6.7	3.1	3.5	5.2	6.7	8	11	15.5	18.6						
	kg (with brake)	6.7	8.2	4.1	4.5	6.7	8.2	9.5	12.6	18.7	21.8						
Brake specifications	Rated voltage	24VDC ±10%															
	Holding brake moment inertia (J)	kg·m ² ×10 ⁻⁴				1.35				4.7							
	Power consumption (20°C)	W		14		19		17		14		19		22		31	
	Current consumption (20°C)	A		0.59±10%		0.79±10%		0.70 ±10%		0.59±10%		0.79 ±10%		0.90±10%		1.3±10%, 1.3 ±10%	
	Static friction torque	N·m (minimum)		4.9		13.7		2.5		4.9		13.7		16.2		24.5	
	Rise time for holding torque	ms (max.)		80		100		50		80		100		110		80	
	Release time	ms (max)		70		50		15		70		50		25			
Basic specifications	Time Rating	Continuous															
	Insulation class	TypeF															
	Ambient operating/ storage temperature	0 to +40 °C/ -20 to 85°C															
	Ambient operating/ storage humidity	20% to 85% (non-condensing)															
	Vibration class	V-15															
	Insulation resistance	20 MΩ min. at 500 VDC between the power terminals and FG terminal															
	Enclosure	Totally-enclosed, self-cooling, IP67 (excluding shaft opening)															
Vibration resistance	Vibration acceleration 49 m/s ²																
Mounting	Flange-mounted																

Torque-speed characteristics

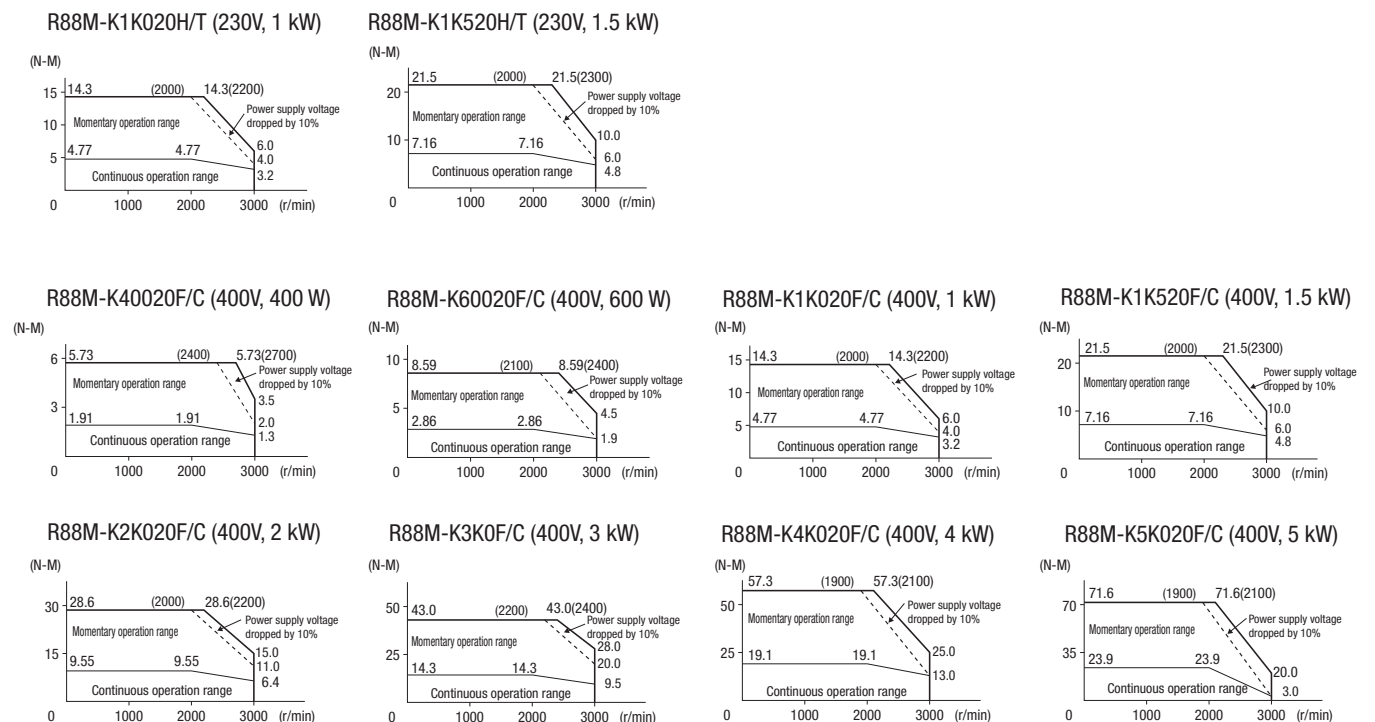

Servo motors 1500 r/min, 400 V

Ratings and specifications

Applied voltage		400 V			
Servo motor model R88M-K□	17-bit absolute encoder	7K515C-□	11K015C-□	15K015C-□	
Rated output	W	7500	11000	15000	
Rated torque	N·m	47.8	70.0	95.5	
Instantaneous peak torque	N·m	119.0	175.0	224.0	
Rated current	A (rms)	22.0	27.1	33.1	
Instantaneous max. current	A (rms)	83	101	118	
Rated speed	min ⁻¹	1500			
Max. speed	min ⁻¹	3000	2000		
Torque constant	N·m/A	1.54	1.84	2.10	
Rotor moment of inertia (JM)	kg·m ² ×10 ⁻⁴ (without brake)	101	212	302	
	kg·m ² ×10 ⁻⁴ (with brake)	107	220	311	
Allowable load moment of inertia (JL)	Multiple of (JM)	10			
Rated power rate	kW/s (without brake)	226	231	302	
	kW/s (with brake)	213	223	293	
Allowable radial load	N	1176	2254		
Allowable thrust load	N	490	686		
Approx. mass	kg (without brake)	36.4	52.7	70.2	
	kg (with brake)	40.4	58.9	76.3	
Brake specifications	Rated voltage	24VDC ±10%			
	Holding brake moment of inertia J	kg·m ² ×10 ⁻⁴	4.7	7.1	
	Power consumption (at 20°C)	W	34	26	
	Current consumption (at 20°C)	A	1.4±10%		1.08±10%
	Static friction torque	N·m (minimum)	58.8	100	
	Rise time for holding torque	ms (max.)	150	300	
Release time	ms (max)	50	140		
Basic specifications	Time Rating	Continuous			
	Insulation class	Type F			
	Ambient operating/ storage temperature	0 to +40 °C/ -20 to 65°C			
	Ambient operating/ storage humidity	20% to 85% RH (non-condensing)			
	Vibration class	V-15			
	Insulation resistance	20 MΩ min. at 500 VDC between the power terminals and FG terminal			
	Enclosure	Totally-enclosed, self-cooling, IP67 (excluding shaft opening)			
	Vibration resistance	Vibration acceleration 49 m/s ²			
Mounting	Flange-mounted				

Torque-speed characteristics

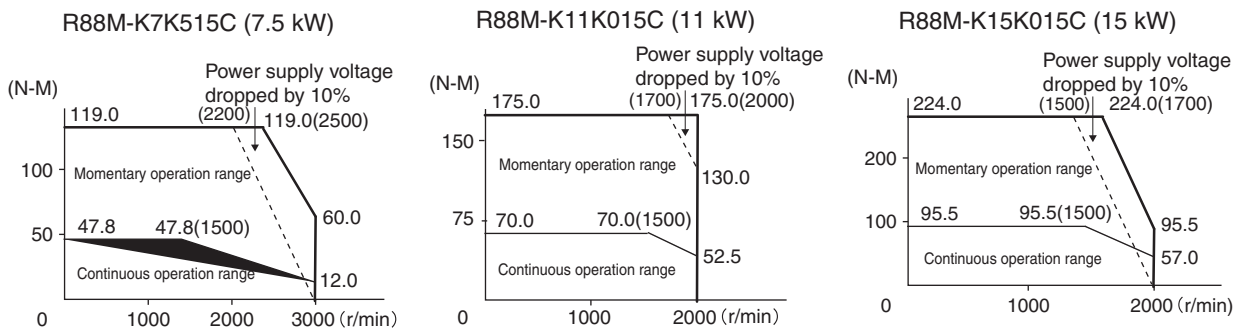

Servo motors 1000 r/min, 230V/ 400 V

Ratings and specifications

Applied voltage		230 V	400 V				
Servo motor model R88M-K□	20-bit incremental encoder	90010H-□	90010F-□	2K010F-□	3K010F-□		
	17-bit absolute encoder	90010T-□	90010C-□	2K010C-□	3K010C-□	4K510C-□	6K010C-□
Rated output	W	900	900	2000	3000	4500	6000
Rated torque	N·m	8.59		19.1	28.7	43.0	57.3
Instantaneous peak torque	N·m	19.3		47.7	71.7	107.0	143.0
Rated current	A (rms)	7.6	3.8	8.5	11.3	14.8	19.4
Instantaneous max. current	A (rms)	24	12	30	40	55	74
Rated speed	min ⁻¹	1000					
Max. speed	min ⁻¹	2000					
Torque constant	N·m/A	0.86	1.72	1.76	1.92	2.05	2.08
Rotor moment of inertia (JM)	kg·m ² ×10 ⁻⁴ (without brake)	6.70		30.3	48.4	79.1	101
	kg·m ² ×10 ⁻⁴ (with brake)	7.99		31.4	49.2	84.4	107
Allowable load moment of inertia (JL)	Multiple of (JM)	10					
Rated power rate	kW/s (without brake)	110		120	170	233	325
	kW/s (with brake)	92.4		116	167	219	307
Allowable radial load	N	686		1176	1470		1764
Allowable thrust load	N	196		490			588
Approx. mass	kg (without brake)	6.7		14	20	29.4	36.4
	kg (with brake)	8.2		17.5	23.5	33.3	40.4
Brake specifications	Rated voltage	24VDC ±10%					
	Holding brake moment of inertia J	kg·m ² ×10 ⁻⁴	1.35		4.7		
	Power consumption (at 20°C)	W	19		31	34	
	Current consumption (at 20°C)	A	0.79±10%		1.3±10%	1.4±10%	
	Static friction torque	N·m (minimum)	13.7		24.5	58.8	
	Rise time for holding torque	ms (max.)	100		80	150	
	Release time	50		25	50		
Basic specifications	Time Rating	Continuous					
	Insulation class	Type F					
	Ambient operating/ storage temperature	0 to +40 °C/ -20 to 65°C					
	Ambient operating/ storage humidity	20% to 85% RH (non-condensing)					
	Vibration class	V-15					
	Insulation resistance	20 MΩ min. at 500 VDC between the power terminals and FG terminal					
	Enclosure	Totally-enclosed, self-cooling, IP67 (excluding shaft opening)					
	Vibration resistance	Vibration acceleration 49 m/s ²					
Mounting	Flange-mounted						

AC Servo systems

Torque-speed characteristics

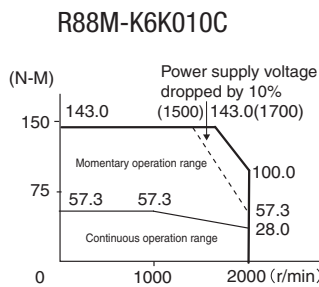
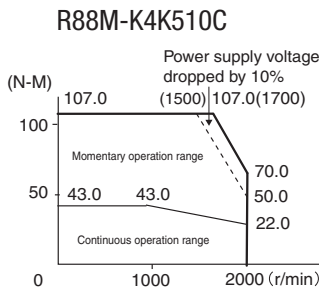
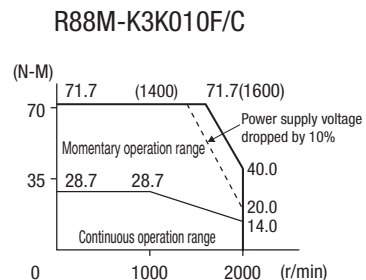
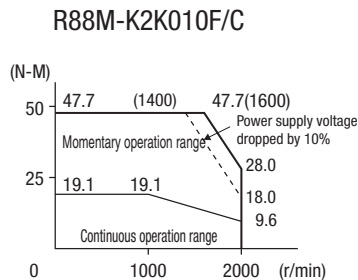
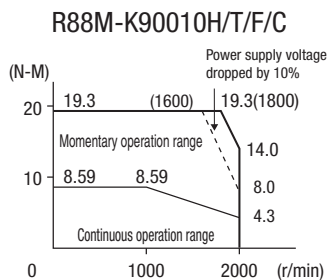

Dimensions

Servomotors

Type 3000 r/min motors (230 V, 50 - 100 W)

Dimensions (mm)	Without brake		With brake		LN	Shaft End Dimensions		Approx. Mass (Kg)	
	LL	LM	LL	LM		Tap x Depth	Without brake	With brake	
R88M-K05030(H/T)-□S2	72	48	102	78	23	M3 x 6L		0.32	0.53
R88M-K10030(H/T)-□S2	92	68	122	98	43			0.47	0.68

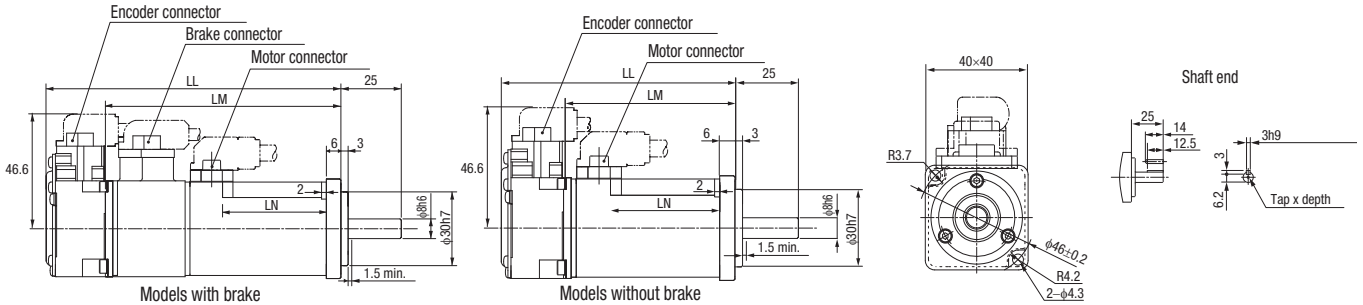

Type 3000 r/min motors (230 V, 200 - 750 W)

Dimensions (mm)	Without brake			With brake			LR	Flange surface						Shaft End Dimensions						Approx. Mass Kg		
	LL	LM	KL1	LL	LM	KL1		LB	LC	LD	LE	LG	LZ	S	K	QK	H	B	T	Tap x Depth	Without brake	With brake
R88M-K20030(H/T)-□S2	79.5	56.5	52.5	116	93	52.5	30	50 ^{h7}	60	70	3	6.5	4.5	11 ^{h6}	20	18	8.5	4 ^{h9}	4	M4x8L	0.82	1.3
R88M-K40030(H/T)-□S2	99	76	52.5	135.5	112.5	52.5								14 ^{h6}	25	22.5	11	5 ^{h9}	5	M5x10L	1.2	1.7
R88M-K75030(H/T)-□S2	112.2	86.2	60	148.2	122.2	61.6	35	70 ^{h7}	80	90		8	6	19 ^{h6}		22	15.5	6 ^{h9}	6		2.3	3.1

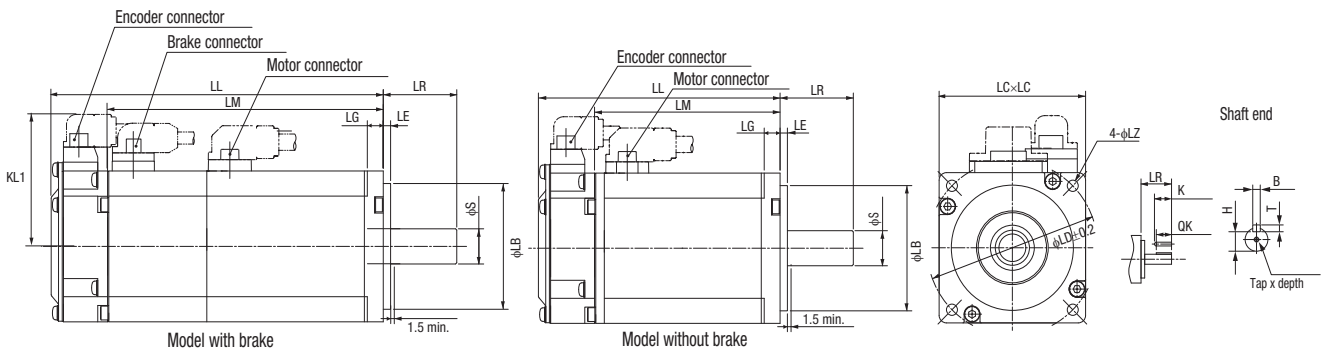

Type 3000 r/min motors (230 V, 1 - 1.5 kW/ 400V, 750 W - 5 kW)

Voltage	Model	Without brake					With brake					LR	Flange surface						Shaft End Dimensions						Approx. Mass (Kg)		
		LL	LM	KB1	KB2	KL1	LL	LM	KB1	KB2	KL1		LA	LB	LC	LD	LE	LG	S	Tap x Depth	K	QK	H	B	T	Without brake	With brake
230	1K030(H/T)-□S2	141	97	66	119	101	168	124	66	146	101	55	135	95 ^{h7}	100	115	3	10	19 ^{h6}	M5x 12L	45	42	15.5	6 ^{h9}	6	3.5	4.5
	1K530(H/T)-□S2	159.5	115.5	84.5	137.5		186.5	142.5	84.5	164.5															4.4	5.4	
400	75030(F/C)-□S2	131.5	87.5	56.5	109.5		158.5	114.5	53.5	136.5	103														3.1	4.1	
	1K030(F/C)-□S2	141	97	66	119		168	124	63	146															3.5	4.5	
	1K530(F/C)-□S2	159.5	115.5	84.5	137.5		186.5	142.5	81.5	164.5															4.4	5.4	
	2K030(F/C)-□S2	178.5	134.5	103.5	156.5		205.5	161.5	100.5	183.5															5.3	6.3	
	3K030(F/C)-□S2	190	146	112	168	113	215	171	112	193	113	65	162	110 ^{h7}	120	145	12	22 ^{h6}			41	18	8 ^{h9}	7	8.3	9.4	
	4K030(F/C)-□S2	208	164	127	186	118	233	189	127	211	118	65	165		130		6	24 ^{h6}	M8x 20L	55	51	20			11	12.6	
	5K030(F/C)-□S2	243	199	162	221		268	224	162	246															14	16	

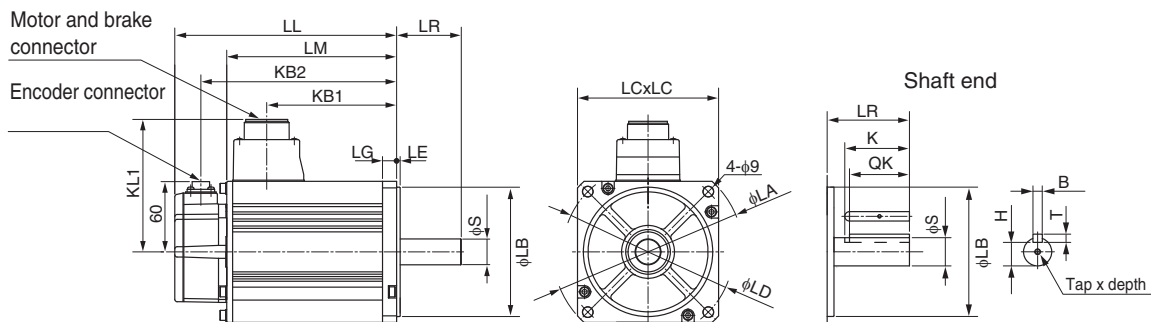

Type 2000 r/min motors (230 V, 1 - 1.5 kW / 400 V, 400W - 5 kW)

Dimensions (mm)		Without brake					With brake					LR	Flange surface							Shaft End Dimensions						Approx. Mass (Kg)		
Voltage	Model	LL	LM	KB1	KB2	KL1	LL	LM	KB1	KB2	KL1		LA	LB	LC	LD	LE	LG	LZ	S	Tap x Depth	K	QK	H	B	T	Without brake	With brake
230	1K020(H/T)-□S2	138	94	60	116	116	163	119	60	141	116	55	165	110 ^{h7}	130	145	6	12	9	22 ^{h6}	M5x12L	45	41	18	8 ^{h9}	7	5.2	6.7
	1K520(H/T)-□S2	155.5	111.5	77.5	133.5	116	180.5	136.5	77.5	158.5	116	55	165	110 ^{h7}	130	145	6	12	9	22 ^{h6}	M5x12L	45	41	18	8 ^{h9}	7	6.7	8.2
400	40020(F/C)-□S2	131.5	87.5	56.5	109.5	101	158.5	114.5	53.5	136.5	103	65	135	95 ^{h7}	100	115	3	10		19 ^{h6}		42	15.5	6 ^{h9}	6	3.1	4.1	
	60020(F/C)-□S2	141	97	66	119	101	168	124	63	146	103	65	135	95 ^{h7}	100	115	3	10		19 ^{h6}		42	15.5	6 ^{h9}	6	3.5	4.5	
	1K020(F/C)-□S2	138	94	60	116	116	163	119	57	141	118	65	165	110 ^{h7}	130	145	6	12		22 ^{h6}		41	18	8 ^{h9}	7	5.2	6.7	
	1K520(F/C)-□S2	155.5	111.5	77.5	133.5	116	180.5	136.5	74.5	158.5	118	65	165	110 ^{h7}	130	145	6	12		22 ^{h6}		41	18	8 ^{h9}	7	6.7	8.2	
	2K020(F/C)-□S2	173	129	95	151	118	198	154	92	176	118	65	165	110 ^{h7}	130	145	6	12		22 ^{h6}		41	18	8 ^{h9}	7	8	9.5	
	3K020(F/C)-□S2	208	164	127	186	118	233	189	127	211	118	65	165	110 ^{h7}	130	145	6	12		22 ^{h6}		41	18	8 ^{h9}	7	11	12.6	
	4K020(F/C)-□S2	177	133	96	155	140	202	158	96	180	140	70	233	114.3 ^{h7}	176	200	3.2	18	13.5	35 ^{h6}	M12x25L	50	30	10 ^{h9}	8	15.5	18.7	
5K020(F/C)-□S2	196	152	115	174	140	221	177	115	199	140	70	233	114.3 ^{h7}	176	200	3.2	18	13.5	35 ^{h6}	M12x25L	50	30	10 ^{h9}	8	18.6	21.8		

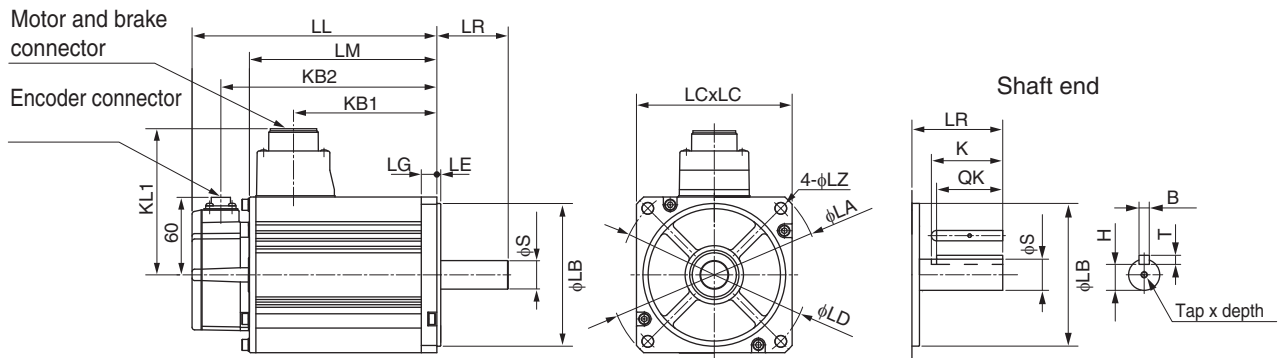

Type 1500 r/min motors (400 V, 7.5kW)

Dimensions (mm)		Without brake							With brake						Approx. Mass (Kg)		
Voltage	Model	LL	LM	KB1	KB2	L1	L2	L3	LL	LM	KB1	KB2	L1	L2	L3	Without brake	With brake
400	7K515C-□S2	312	268	219	290	117.5	117.5	149	337	293	253	315	117.5	152.5	183	36.4	40.4

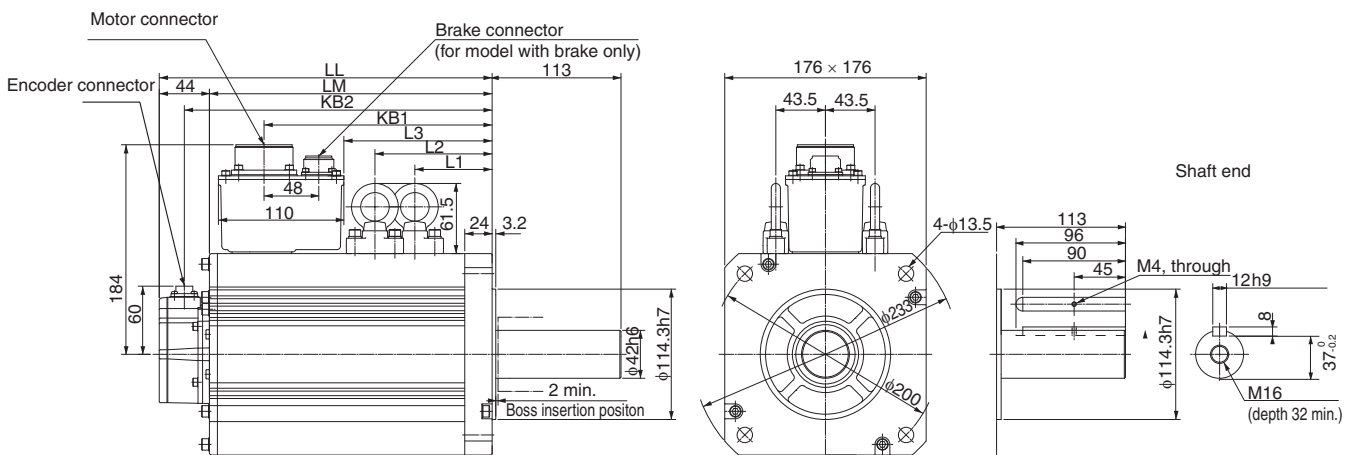

Type 1500 r/min motors (400 V, 11 - 15 kW)

Dimensions (mm)		Without brake							With brake							Approx. Mass (Kg)	
Voltage	Model	LL	LM	KB1	KB2	L1	L2	L3	LL	LM	KB1	KB2	L1	L2	L3	Without brake	With brake
400	R88M-K□																
	11K015C-□S2	316	272	232	294	124.5	124.5	162	364	320	266	342	124.5	159.5	196	52.7	58.9
	15K015C-□S2	384	340	300	362	158.5	158.5	230	432	388	334	410	158.5	193.5	264	70.2	76.3

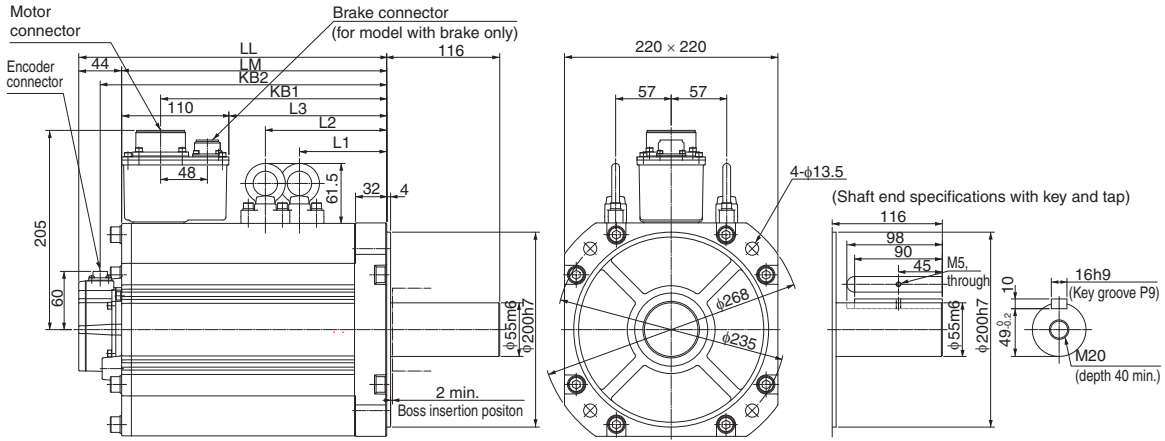

Type 1000 r/min motors (230 V, 900W / 400 V, 900W - 3 kW)

Dimensions (mm)		Without brake					With brake					LR	Flange surface							Shaft End Dimensions						Approx. Mass (Kg)		
Voltage	Model	LL	LM	KB1	KB2	KL1	LL	LM	KB1	KB2	KL1		LA	LB	LC	LD	LE	LG	LZ	S	Tap x Depth	K	QK	H	B	T	Without brake	With brake
230	90010(H/T)-□S2	155.5	111.5	77.5	133.5	116	180.5	136.5	77.5	158.5	116	70	165	110 ^{h7}	130	145	6	12	9	22 ^{h6}	M5x12L	45	41	18	8 ^{h9}	7	6.7	8.2
	90010(F/C)-□S2								74.5	118																		
	2K010(F/C)-□S2	163.5	119.5	82.5	141.5	140	188.5	144.5	82.5	166.5	140	80	233	114.3 ^{h7}	176	200	3.2	18	13.5	35 ^{h6}	M12x 25L	55	50	30	10 ^{h9}	8	14	17.5
	3K010(F/C)-□S2	209.5	165.5	128.5	187.5		234.5	190.5	128.5	212.5																20	23.5	

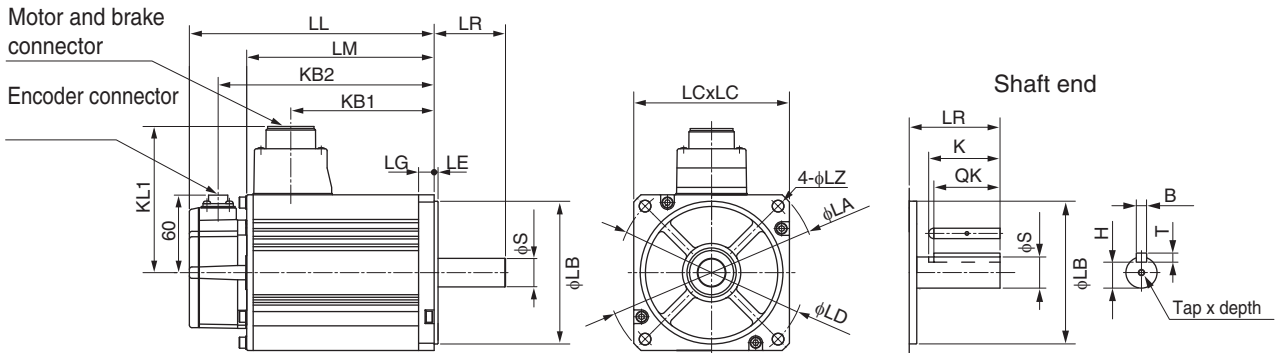

Type 1000 r/min motors (400 V, 4.5 kW)

Dimensions (mm)		Without brake						With brake						Approx. Mass (Kg)	
Voltage	Model	LL	LM	KB1	KB2	L1	L2	LL	LM	KB1	KB2	L1	L2	Without brake	With brake
	R88M-K□														
400	4K510C-□S2	266	222	185	244	98	98	291	247	185	269	98	133	29.4	33.3

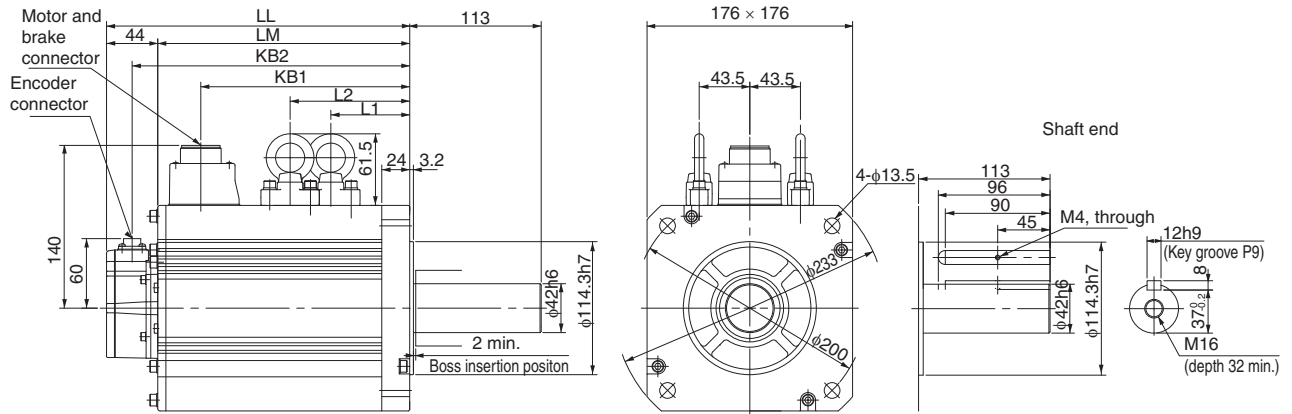

Type 1000 r/min motors (400 V, 6 kW)

Dimensions (mm)		Without brake							With brake							Approx. Mass (Kg)	
Voltage	Model	LL	LM	KB1	KB2	L1	L2	L3	LL	LM	KB1	KB2	L1	L2	L3	Without brake	With brake
	R88M-K□																
400	6K010C-□S2	312	268	219	290	117.5	117.5	149	337	293	253	315	117.5	152.5	183	36.4	40.4

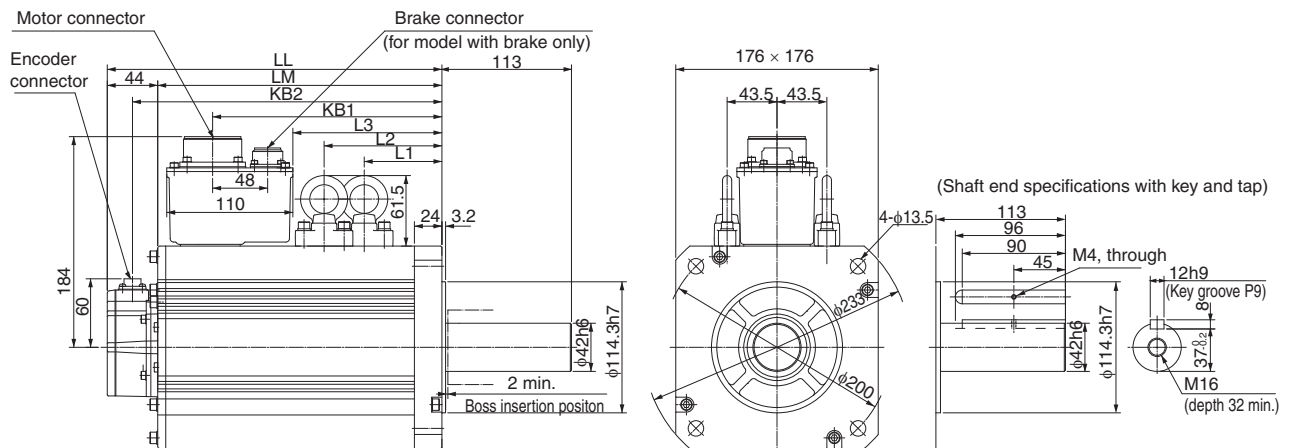

Ordering information

(Refer to servo drive chapter)

② Drive options

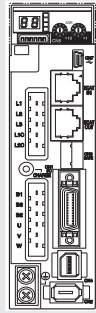

Accurax G5 servo drives
EtherCAT, ML2 and
Analog/Pulse models

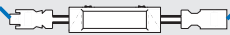

④ Extension cable for
Absolute encoder (with battery holder)

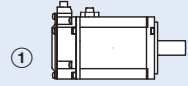
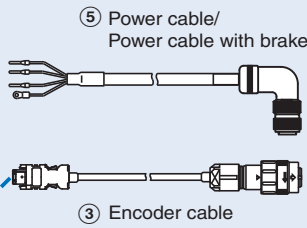
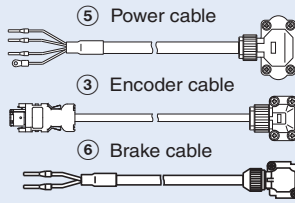

Servo motor
3000 rpm (50 W-750 W)

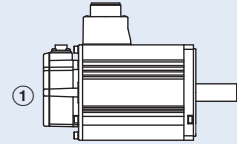

Servo motor
3000 rpm (750 W-5 kW)
2000 rpm (400 W-5 kW)
1000 rpm (900 W-3 kW)

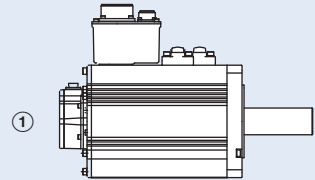

Servo motor
1500 rpm (7.5 kW-15 kW)
1000 rpm (4.5 kW-6 kW)

Note: The symbols ①②③... show the recommended sequence to select the servo motor and cables



Servo motor

① Select motor from R88M-K family using motor tables in next pages.

Servo drive

② Refer to Accurax G5 servo drive chapter for detailed drive specifications and selection of drive accessories.

Servo motors 3000 r/min (50 - 5000 W)

Symbol	Specifications				Servo motor model	Compatible servo drives (2)		
	Voltage	Encoder and design	Rated torque	Capacity		G5 EtherCAT/ ML2	G5 Analog/Pulse	
<p>①</p>  <p>230V (50 - 750 W)</p>  <p>230V (1 kW - 1.5 kW) 400V (750 W - 5 kW)</p>	230 V	Incremental encoder (20 bit) Straight shaft with key and tap	Without brake	0.16 Nm	50 W	R88M-K05030H-S2	R88D-KN01H-□	R88D-KT01H
				0.32 Nm	100 W	R88M-K10030H-S2	R88D-KN01H-□	R88D-KT01H
				0.64 Nm	200 W	R88M-K20030H-S2	R88D-KN02H-□	R88D-KT02H
				1.3 Nm	400 W	R88M-K40030H-S2	R88D-KN04H-□	R88D-KT04H
				2.4 Nm	750 W	R88M-K75030H-S2	R88D-KN08H-□	R88D-KT08H
			3.18 Nm	1000 W	R88M-K1K030H-S2	R88D-KN15H-□	R88D-KT15H	
			4.77 Nm	1500 W	R88M-K1K530H-S2	R88D-KN15H-□	R88D-KT15H	
			With brake	0.16 Nm	50 W	R88M-K05030H-BS2	R88D-KN01H-□	R88D-KT01H
				0.32 Nm	100 W	R88M-K10030H-BS2	R88D-KN01H-□	R88D-KT01H
				0.64 Nm	200 W	R88M-K20030H-BS2	R88D-KN02H-□	R88D-KT02H
		1.3 Nm		400 W	R88M-K40030H-BS2	R88D-KN04H-□	R88D-KT04H	
		2.4 Nm		750 W	R88M-K75030H-BS2	R88D-KN08H-□	R88D-KT08H	
		Absolute encoder (17 bit) Straight shaft with key and tap	Without brake	0.16 Nm	50 W	R88M-K05030T-S2	R88D-KN01H-□	R88D-KT01H
				0.32 Nm	100 W	R88M-K10030T-S2	R88D-KN01H-□	R88D-KT01H
				0.64 Nm	200 W	R88M-K20030T-S2	R88D-KN02H-□	R88D-KT02H
				1.3 Nm	400 W	R88M-K40030T-S2	R88D-KN04H-□	R88D-KT04H
				2.4 Nm	750 W	R88M-K75030T-S2	R88D-KN08H-□	R88D-KT08H
			3.18 Nm	1000 W	R88M-K1K030T-S2	R88D-KN15H-□	R88D-KT15H	
			4.77 Nm	1500 W	R88M-K1K530T-S2	R88D-KN15H-□	R88D-KT15H	
			With brake	0.16 Nm	50 W	R88M-K05030T-BS2	R88D-KN01H-□	R88D-KT01H
	0.32 Nm			100 W	R88M-K10030T-BS2	R88D-KN01H-□	R88D-KT01H	
	0.64 Nm			200 W	R88M-K20030T-BS2	R88D-KN02H-□	R88D-KT02H	
	1.3 Nm	400 W		R88M-K40030T-BS2	R88D-KN04H-□	R88D-KT04H		
	2.4 Nm	750 W		R88M-K75030T-BS2	R88D-KN08H-□	R88D-KT08H		
	400 V	Incremental encoder (20 bit) Straight shaft with key and tap	Without brake	2.39 Nm	750 W	R88M-K75030F-S2	R88D-KN10F-□	R88D-KT10F
				3.18 Nm	1000 W	R88M-K1K030F-S2	R88D-KN15F-□	R88D-KT15F
				4.77 Nm	1500 W	R88M-K1K530F-S2	R88D-KN15F-□	R88D-KT15F
				6.37 Nm	2000 W	R88M-K2K030F-S2	R88D-KN20F-□	R88D-KT20F
				9.55 Nm	3000 W	R88M-K3K030F-S2	R88D-KN30F-□	R88D-KT30F
			With brake	2.39 Nm	750 W	R88M-K75030F-BS2	R88D-KN10F-□	R88D-KT10F
				3.18 Nm	1000 W	R88M-K1K030F-BS2	R88D-KN15F-□	R88D-KT15F
				4.77 Nm	1500 W	R88M-K1K530F-BS2	R88D-KN15F-□	R88D-KT15F
				6.37 Nm	2000 W	R88M-K2K030F-BS2	R88D-KN20F-□	R88D-KT20F
				9.55 Nm	3000 W	R88M-K3K030F-BS2	R88D-KN30F-□	R88D-KT30F
		Absolute encoder (17 bit) Straight shaft with key and tap	Without brake	2.39 Nm	750 W	R88M-K75030C-S2	R88D-KN10F-□	R88D-KT10F
				3.18 Nm	1000 W	R88M-K1K030C-S2	R88D-KN15F-□	R88D-KT15F
				4.77 Nm	1500 W	R88M-K1K530C-S2	R88D-KN15F-□	R88D-KT15F
				6.37 Nm	2000 W	R88M-K2K030C-S2	R88D-KN20F-□	R88D-KT20F
				9.55 Nm	3000 W	R88M-K3K030C-S2	R88D-KN30F-□	R88D-KT30F
			With brake	2.39 Nm	750 W	R88M-K75030C-BS2	R88D-KN10F-□	R88D-KT10F
3.18 Nm				1000 W	R88M-K1K030C-BS2	R88D-KN15F-□	R88D-KT15F	
4.77 Nm				1500 W	R88M-K1K530C-BS2	R88D-KN15F-□	R88D-KT15F	
6.37 Nm				2000 W	R88M-K2K030C-BS2	R88D-KN20F-□	R88D-KT20F	
9.55 Nm				3000 W	R88M-K3K030C-BS2	R88D-KN30F-□	R88D-KT30F	
12.7 Nm	4000 W	R88M-K4K030C-BS2	R88D-KN50F-□	R88D-KT50F				
	15.9 Nm	5000 W	R88M-K5K030C-BS2	R88D-KN50F-□	R88D-KT50F			



Servo motors 2000 r/min (1 - 5 kW)

Symbol	Specifications				Servo motor model	Compatible servo drives (2)			
	Voltage	Encoder and design	Rated torque	Capacity		G5 EtherCAT/ ML2	G5 Analog/Pulse		
	230 V	Incremental encoder (20 bit) Straight shaft with key and tap	Without brake	4.77 Nm	1000 W	R88M-K1K020H-S2	R88D-KN10H-□	R88D-KT10H	
				7.16 Nm	1500 W	R88M-K1K520H-S2	R88D-KN15H-□	R88D-KT15H	
			With brake	4.77 Nm	1000 W	R88M-K1K020H-BS2	R88D-KN10H-□	R88D-KT10H	
				7.16 Nm	1500 W	R88M-K1K520H-BS2	R88D-KN15H-□	R88D-KT15H	
		Absolute encoder (17 bit) Straight shaft with key and tap	Without brake	4.77 Nm	1000 W	R88M-K1K020T-S2	R88D-KN10H-□	R88D-KT10H	
				7.16 Nm	1500 W	R88M-K1K520T-S2	R88D-KN15H-□	R88D-KT15H	
			With brake	4.77 Nm	1000 W	R88M-K1K020T-BS2	R88D-KN10H-□	R88D-KT10H	
				7.16 Nm	1500 W	R88M-K1K520T-BS2	R88D-KN15H-□	R88D-KT15H	
		400 V	Incremental encoder (20 bit) Straight shaft with key and tap	Without brake	1.91 Nm	400 W	R88M-K40020F-S2	R88D-KN06F-□	R88D-KT06F
					2.86 Nm	600 W	R88M-K60020F-S2	R88D-KN06F-□	R88D-KT06F
					4.77 Nm	1000 W	R88M-K1K020F-S2	R88D-KN10F-□	R88D-KT10F
					7.16 Nm	1500 W	R88M-K1K520F-S2	R88D-KN15F-□	R88D-KT15F
	9.55 Nm				2000 W	R88M-K2K020F-S2	R88D-KN20F-□	R88D-KT20F	
	14.3 Nm				3000 W	R88M-K3K020F-S2	R88D-KN30F-□	R88D-KT30F	
	With brake			19.1 Nm	4000 W	R88M-K4K020F-S2	R88D-KN50F-□	R88D-KT50F	
				23.9 Nm	5000 W	R88M-K5K020F-S2	R88D-KN50F-□	R88D-KT50F	
				1.91 Nm	400 W	R88M-K40020F-BS2	R88D-KN06F-□	R88D-KT06F	
				2.86 Nm	600 W	R88M-K60020F-BS2	R88D-KN06F-□	R88D-KT06F	
				4.77 Nm	1000 W	R88M-K1K020F-BS2	R88D-KN10F-□	R88D-KT10F	
				7.16 Nm	1500 W	R88M-K1K520F-BS2	R88D-KN15F-□	R88D-KT15F	
	Absolute encoder (17 bit) Straight shaft with key and tap		Without brake	9.55 Nm	2000 W	R88M-K2K020F-BS2	R88D-KN20F-□	R88D-KT20F	
				14.3 Nm	3000 W	R88M-K3K020F-BS2	R88D-KN30F-□	R88D-KT30F	
				19.1 Nm	4000 W	R88M-K4K020F-BS2	R88D-KN50F-□	R88D-KT50F	
				23.9 Nm	5000 W	R88M-K5K020F-BS2	R88D-KN50F-□	R88D-KT50F	
				1.91 Nm	400 W	R88M-K40020C-S2	R88D-KN06F-□	R88D-KT06F	
				2.86 Nm	600 W	R88M-K60020C-S2	R88D-KN06F-□	R88D-KT06F	
			With brake	4.77 Nm	1000 W	R88M-K1K020C-S2	R88D-KN10F-□	R88D-KT10F	
				7.16 Nm	1500 W	R88M-K1K520C-S2	R88D-KN15F-□	R88D-KT15F	
				9.55 Nm	2000 W	R88M-K2K020C-S2	R88D-KN20F-□	R88D-KT20F	
				14.3 Nm	3000 W	R88M-K3K020C-S2	R88D-KN30F-□	R88D-KT30F	
19.1 Nm				4000 W	R88M-K4K020C-S2	R88D-KN50F-□	R88D-KT50F		
23.9 Nm				5000 W	R88M-K5K020C-S2	R88D-KN50F-□	R88D-KT50F		

Servo motors 1500 r/min (7.5 - 15 KW)

Symbol	Specifications				Servo motor model	Compatible servo drives (2)		
	Voltage	Encoder and design	Rated torque	Capacity		G5 EtherCAT	G5 Analog/Pulse	
	400 V	Absolute encoder (17 bit) Straight shaft with key and tap	Without brake	47.8 Nm	7500 W	R88M-K7K515C-S2	R88D-KN75F-ECT	R88D-KT75F
				70.0 Nm	11000 W	R88M-K11K015C-S2	R88D-KN150F-ECT	R88D-KT150F
				95.5 Nm	15000 W	R88M-K15K015C-S2	R88D-KN150F-ECT	R88D-KT150F
			With brake	47.8 Nm	7500 W	R88M-K7K515C-BS2	R88D-KN75F-ECT	R88D-KT75F
				70.0 Nm	11000 W	R88M-K11K015C-BS2	R88D-KN150F-ECT	R88D-KT150F
				95.5 Nm	15000 W	R88M-K15K015C-BS2	R88D-KN150F-ECT	R88D-KT150F

Servo motors 1000 r/min (900 - 6000 W)

Symbol	Specifications				Servo motor model	Compatible servo drives (2)			
	Voltage	Encoder and design		Rated torque		Capacity	G5 EtherCAT	G5 Analog/Pulse	G5 ML2
 900 W - 3 kW  4.5 kW - 6 kW	230 V	Incremental encoder (20 bit) Straight shaft with key and tap	No brake	8.59 Nm	900 W	R88M-K90010H-S2	R88D-KN15H-ECT	R88D-KT15H	R88D-KN15H-ML2
			With brake	8.59 Nm	900 W	R88M-K90010H-BS2	R88D-KN15H-ECT	R88D-KT15H	R88D-KN15H-ML2
		Absolute encoder (17 bit) Straight shaft with key and tap	No brake	8.59 Nm	900 W	R88M-K90010T-S2	R88D-KN15H-ECT	R88D-KT15H	R88D-KN15H-ML2
			With brake	8.59 Nm	900 W	R88M-K90010T-BS2	R88D-KN15H-ECT	R88D-KT15H	R88D-KN15H-ML2
	400 V	Incremental encoder (20 bit) Straight shaft with key and tap	No brake	8.59 Nm	900 W	R88M-K90010F-S2	R88D-KN15F-ECT	R88D-KT15F	R88D-KN15F-ML2
				19.1 Nm	2000 W	R88M-K2K010F-S2	R88D-KN30F-ECT	R88D-KT30F	R88D-KN30F-ML2
			With brake	8.59 Nm	900 W	R88M-K90010F-BS2	R88D-KN15F-ECT	R88D-KT15F	R88D-KN15F-ML2
				19.1 Nm	2000 W	R88M-K2K010F-BS2	R88D-KN30F-ECT	R88D-KT30F	R88D-KN30F-ML2
		Absolute encoder (17 bit) Straight shaft with key and tap	No brake	8.59 Nm	900 W	R88M-K90010C-S2	R88D-KN15F-ECT	R88D-KT15F	R88D-KN15F-ML2
				19.1 Nm	2000 W	R88M-K2K010C-S2	R88D-KN30F-ECT	R88D-KT30F	R88D-KN30F-ML2
			With brake	8.59 Nm	900 W	R88M-K90010C-BS2	R88D-KN15F-ECT	R88D-KT15F	R88D-KN15F-ML2
				19.1 Nm	2000 W	R88M-K2K010C-BS2	R88D-KN30F-ECT	R88D-KT30F	R88D-KN30F-ML2

Encoder cables

for absolute and incremental encoders

Symbol	Specifications	Model	Appearance
③	Encoder cable for servomotors R88M-K(050/100/200/400/750)30(H/T)□	1.5 m	R88A-CRKA001-5CR-E
		3 m	R88A-CRKA003CR-E
		5 m	R88A-CRKA005CR-E
		10 m	R88A-CRKA010CR-E
		15 m	R88A-CRKA015CR-E
	Encoder cable for servomotors R88M-K(1K0/1K5)30(H/T)□ R88M-K(750/1K0/1K5/2K0/3K0/4K0/5K0)30(F/C)□ R88M-K(400/600/1K0/1K5/2K0/3K0/4K0/5K0)20□ R88M-K(7K5/11K0/15K0)15□ R88M-K(900/2K0/3K0/4K5/6K0)10□	20 m	R88A-CRKA020CR-E
		1.5 m	R88A-CRKC001-5NR-E
		3 m	R88A-CRKC003NR-E
		5 m	R88A-CRKC005NR-E
		10 m	R88A-CRKC010NR-E

Note: For servomotors fitted with an absolute encoder you have to add the extension battery cable R88A-CRGD0R3C□ (see below) or connect a backup battery in the CN1 I/O connector.

Absolute encoder battery cable (encoder extension cable only)

Symbol	Specifications	Model	Appearance	
④	Absolute encoder battery cable	Battery not included	0.3 m	R88A-CRGD0R3C-E
		Battery included	0.3 m	R88A-CRGD0R3C-BS-E
	Absolute encoder backup battery	2,000 mA.h 3.6V	-	R88A-BAT01G

Power cables

Symbol	Specifications		Model	Appearance	
⑤	For 200 V servomotors R88M-K(050/100/200/400/750)30(H/T)□ Note: for servomotors with brake R88M-K(050/100/200/400/750)30(H/T)-BS2, the separate brake cable R88A-CAKA□□□BR-E is needed	Power cable only (without brake)	1.5 m	R88A-CAKA001-5SR-E	
			3 m	R88A-CAKA003SR-E	
			5 m	R88A-CAKA005SR-E	
			10 m	R88A-CAKA010SR-E	
			15 m	R88A-CAKA015SR-E	
			20 m	R88A-CAKA020SR-E	
	For 200 V servomotors R88M-K(1K0/1K5)30(H/T)□ R88M-K(1K0/1K5)20(H/T)□ R88M-K90010(H/T)□	without brake □-S2	1.5 m	R88A-CAGB001-5SR-E	
			3 m	R88A-CAGB003SR-E	
			5 m	R88A-CAGB005SR-E	
			10 m	R88A-CAGB010SR-E	
			15 m	R88A-CAGB015SR-E	
			20 m	R88A-CAGB020SR-E	
		with brake □-BS2	1.5 m	R88A-CAGB001-5BR-E	
			3 m	R88A-CAGB003BR-E	
			5 m	R88A-CAGB005BR-E	
			10 m	R88A-CAGB010BR-E	
			15 m	R88A-CAGB015BR-E	
			20 m	R88A-CAGB020BR-E	
	For 400 V servomotors R88M-K(750/1K0/1K5/2K)30(F/C)□ R88M-K(400/600/1K0/1K5/2K0)20(F/C)□ R88M-K90010(F/C)□	without brake □-S2	1.5 m	R88A-CAGB001-5SR-E	
			3 m	R88A-CAGB003SR-E	
			5 m	R88A-CAGB005SR-E	
			10 m	R88A-CAGB010SR-E	
			15 m	R88A-CAGB015SR-E	
			20 m	R88A-CAGB020SR-E	
with brake □-BS2		1.5 m	R88A-CAKF001-5BR-E		
		3 m	R88A-CAKF003BR-E		
		5 m	R88A-CAKF005BR-E		
		10 m	R88A-CAKF010BR-E		
		15 m	R88A-CAKF015BR-E		
		20 m	R88A-CAKF020BR-E		
For 400 V servomotors R88M-K(3K0/4K0/5K0)30(F/C)□ R88M-K(3K0/4K0/5K0)20(F/C)□ R88M-K(2K0/3K0)10(F/C)□ R88M-K4K510C□	without brake □-S2	1.5 m	R88A-CAGD001-5SR-E		
		3 m	R88A-CAGD003SR-E		
		5 m	R88A-CAGD005SR-E		
		10 m	R88A-CAGD010SR-E		
		15 m	R88A-CAGD015SR-E		
		20 m	R88A-CAGD020SR-E		
	with brake □-BS2	1.5 m	R88A-CAGD001-5BR-E		
		3 m	R88A-CAGD003BR-E		
		5 m	R88A-CAGD005BR-E		
		10 m	R88A-CAGD010BR-E		
		15 m	R88A-CAGD015BR-E		
		20 m	R88A-CAGD020BR-E		
For 400 V servomotors R88M-K6K010C□ R88M-K7K515C□ Note: for servomotors with brake R88M-K(6K010/7K515)C-BS2 the separate brake cable R88A-CAGE□□□BR-E is needed	Power cable only (without brake)	1.5 m	R88A-CAKE001-5SR-E		
		3 m	R88A-CAKE003SR-E		
		5 m	R88A-CAKE005SR-E		
		10 m	R88A-CAKE010SR-E		
		15 m	R88A-CAKE015SR-E		
		20 m	R88A-CAKE020SR-E		
For 400 V servomotors R88M-K(11K0/15K0)15C Note: for servomotors with brake R88M-K(11K0/15K0)15C-BS2, the separate brake cable R88A-CAGE□□□BR-E is needed	Power cable only (without brake)	1.5 m	R88A-CAKG001-5SR-E		
		3 m	R88A-CAKG003SR-E		
		5 m	R88A-CAKG005SR-E		
		10 m	R88A-CAKG010SR-E		
		15 m	R88A-CAKG015SR-E		
		20 m	R88A-CAKG020SR-E		

Brake cables (for 200 V 50-750 W servo motors and 400 V 6-15 kW servo motors)

Symbol	Specifications		Model	Appearance
⑥	Brake cable only. For 200 V servo motors with brake R88M-K(050/100/200/400/750)30(H/T)-BS2	1.5 m	R88A-CAKA001-5BR-E	
		3 m	R88A-CAKA003BR-E	
		5 m	R88A-CAKA005BR-E	
		10 m	R88A-CAKA010BR-E	
		15 m	R88A-CAKA015BR-E	
		20 m	R88A-CAKA020BR-E	
	Brake cable only. For 400 V servo motors with brake R88M-K6K010C-BS2 R88M-K(7K5/11K0/15K0)15C-BS2	1.5 m	R88A-CAGE001-5BR-E	
		3 m	R88A-CAGE003BR-E	
		5 m	R88A-CAGE005BR-E	
		10 m	R88A-CAGE010BR-E	
		15 m	R88A-CAGE015BR-E	
		20 m	R88A-CAGE020BR-E	

Connectors for encoder, power and brake cables

Specifications	Applicable Servomotor	Model	
Connectors for making encoder cables	Drive side (CN2)	All models	R88A-CNW01R
	Motor side	R88M-K(050/100/200/400/750)30(H/T)□	R88A-CNK02R
	Motor side	R88M-K(1K0/1K5)30(H/T)□ R88M-K(750/1K0/1K5/2K0/3K0/4K0/5K0)30(F/C)□ R88M-K(400/600/1K0/1K5/2K0/3K0/4K0/5K0)20□ R88M-K(900/2K0/3K0)10□ R88M-K(4K5/6K0)10C-□ R88M-K(7K5/11K0/15K0)15C-□	R88A-CNK04R
Connectors for making power cables	Motor side	R88M-K(050/100/200/400/750)30(H/T)□	R88A-CNK11A
	Motor side	R88M-K(1K0/1K5)30(H/T)-S2 R88M-K(1K0/1K5)20(H/T)-S2 R88M-K90010(H/T)-S2 R88M-K(750/1K0/1K5/2K0)30(F/C)-S2, R88M-K(400/600/1K0/1K5/2K0)20(F/C)-S2 R88M-K90010(F/C)-S2	MS3108E20-4S
	Motor side	R88M-K(1K0/1K5)30(H/T)-BS2 R88M-K(1K0/1K5)20(H/T)-BS2 R88M-K90010(H/T)-BS2	MS3108E20-18S
	Motor side	R88M-K(750/1K0/1K5/2K0/3K0/4K0/5K0)30(F/C)-BS2 R88M-K(400/600/1K0/1K5/2K0/3K0/4K0/5K0)20(F/C)-BS2 R88M-K(900/2K0/3K0)10(F/C)-BS2 R88M-K4K510C-BS2	MS3108E24-11S
	Motor side	R88M-K(3K0/4K0/5K0)30(F/C)-S2 R88M-K(3K0/4K0/5K0)20(F/C)-S2 R88M-K(2K0/3K0)10(F/C)-S2 R88M-K4K510C-S2	MS3108E22-22S
	Motor side	R88M-K6K010C-□ R88M-K(7K5/11K0/15K0)15C-□	MS3108E32-17S
Connector for brake cable	Motor side	R88M-K(050/100/200/400/750)30(H/T)-BS2	R88A-CNK11B
	Motor side	R88M-K6K010C-BS2 R88M-K(7K5/11K0/15K0)15C-BS2	MS3108E14S-2S

- Note:** 1. All cables listed are flexible and shielded (except the R88A-CAKA□□□-BR-E which is only a flexible cable).
 2. All connectors and cables listed have IP67 class (except R88A-CNW01R connector and R88A-CRGD0R3C cable).

AC Servo systems

ALL DIMENSIONS SHOWN ARE IN MILLIMETERS.
To convert millimeters into inches, multiply by 0.03937. To convert grams into ounces, multiply by 0.03527.

R88M-G□

G-Series servo motors

A wide range of compact servomotors to meet all application needs

- Peak torque 300% of continuous torque during 3 seconds or more depending on model
- Servomotors supported by SmartStep2, G-Series and Accurax G5 servo drives
- Cylindrical and Flat servomotors types are available
- Encoder accuracy of 10,000 step/rev as standard and 17-bit INC/ABS encoder as optional
- IP65 as standard and shaft oil seal available
- Motors with brake as option

Ratings

- 230 VAC Single-phase 50 W to 1.5 kW (rated torque from 0.16 to 8.62 Nm)



AC Servo systems

System configuration

G-Series Cylindrical type Servo motor

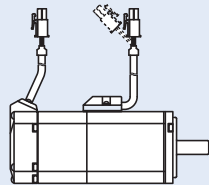

3000 rpm (50-750W)

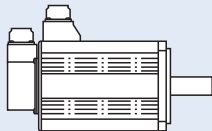

3000 rpm (1000-1500 W)
2000 rpm (1000-1500 W)
1000 rpm (900 W)

Power cable



Encoder cable

G-Series Flat type Servo motor

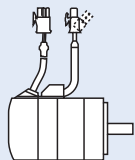

3000 rpm (100-400 W)

(Refer to servo drive chapter)

Drive options

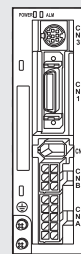

SmartStep 2
Servo drive controlled by pulses

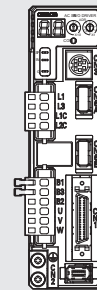

G-Series Servo drive
ML2 and Analogue/ pulse models

Servo motor / servo drive combination

		Servo motor					Servo drive			
Family		Voltage	Speed	Rated torque	Capacity	Model	SmartStep2 ³	G-Series ML2	G-Series A/P	
Cylindric	50-750 W	230 V	3000 min ⁻¹	0.16 Nm	50 W	R88M-G05030□-□S2	R7D-BP01H	R88D-GN01H-ML2	R88D-GT01H	
				0.32 Nm	100 W	R88M-G10030□-□S2	R7D-BP01H	R88D-GN01H-ML2	R88D-GT01H	
				0.64 Nm	200 W	R88M-G20030□-□S2	R7D-BP02HH	R88D-GN02H-ML2	R88D-GT02H	
				1.3 Nm	400 W	R88M-G40030□-□S2	R7D-BP04H	R88D-GN04H-ML2	R88D-GT04H	
				2.4 Nm	750 W	R88M-G75030□-□S2	R88D-GP08H	R88D-GN08H-ML2	R88D-GT08H	
	900-1500 W		2000 min ⁻¹	3.18 Nm	1000 W	R88M-G1K030T-□S2	-	R88D-GN15H-ML2	R88D-GT15H	
				4.77 Nm	1500 W	R88M-G1K530T-□S2	-	R88D-GN15H-ML2	R88D-GT15H	
				1000 min ⁻¹	4.8 Nm	1000 W	R88M-G1K020T-□S2	-	R88D-GN10H-ML2	R88D-GT10H
					7.15 Nm	1500 W	R88M-G1K520T-□S2	-	R88D-GN15H-ML2	R88D-GT15H
				8.62 Nm	900 W	R88M-G90010T-□S2	-	R88D-GN15H-ML2	R88D-GT15H	
Flat	100-400 W	3000 min ⁻¹	0.32 Nm	100 W	R88M-GP10030□-□S2	R7D-BP01H	R88D-GN01H-ML2	R88D-GT01H		
			0.64 Nm	200 W	R88M-GP20030□-□S2	R7D-BP02HH	R88D-GN02H-ML2	R88D-GT02H		
			1.3 Nm	400 W	R88M-GP40030□-□S2	R7D-BP04H	R88D-GN04H-ML2	R88D-GT04H		

- Note:**
1. For servo motor and cables part numbers refer to ordering information at the end of this chapter
 2. Refer to the servo drive chapter for drive options selection and detailed specifications
 3. SmartStep2 only supports incremental encoder

Type designation

Servo motor

R88M-GP10030H-BOS2

G-Series Servo motor

Motor type

Blank: Cylinder type
P: Flat type

Capacity

050	50 W
100	100 W
200	200 W
400	400 W
750	750 W
900	900 W
1K0	1 kW
1K5	1.5 kW

Rated speed (r/min)

10	1000
20	2000
30	3000

Shaft end specifications

Blank	Straigh shaft, no key
S2	Straigh, key, tapped

Oil seal specifications

Blank	No oil seal
O	Oil seal

Brake specifications

Blank	No brake
B	Brake

Voltage and encoder specifications

H: 230 V with incremental encoder
T: 230 V with absolute encoder

Servo motor specifications

Cylindrical servo motors 3000/2000/1000 r/min

Ratings and specifications

Applied voltage		230 V									
Servo motor model R88M-□		G05030	G10030	G20030	G40030	G75030	G1K030T	G1K530T	G1K020T	G1K520T	G90010T
Rated output	W	50	100	200	400	750	1000	1500	1000	1500	900
Rated torque	N·m	0.16	0.32	0.64	1.3	2.4	3.18	4.77	4.8	7.15	8.62
Instantaneous peak torque	N·m	0.45	0.90	1.78	3.67	7.05	9.1	12.8	13.5	19.6	18.4
Rated current	A (rms)	1.1		1.6	2.6	4	7.2	9.4	5.6	9.4	7.6
Instantaneous max. current	A (rms)	3.4		4.9	7.9	12.1	21.4	28.5	17.1	28.5	17.1
Rated speed	min ⁻¹	3000						2000			1000
Max. speed	min ⁻¹	5000				4500	5000		3000		2000
Torque constant	N·m/A (rms)	0.14	0.19	0.41	0.51	0.64	0.44	0.51	0.88	0.76	1.13
Rotor moment of inertia (JM)	kg·m ² ×10 ⁻⁴	0.025	0.051	0.14	0.26	0.87	1.69	2.59	6.17	11.2	
Allowable load moment of inertia (JL)	Multiple of (JM)	30				20	15		10		
Rated power rate	kW/s	10.4	20.1	30.3	62.5	66	60	88	37.3	45.8	66.3
Applicable Encoder		Incremental encoder (10000 pulses)						-			
		Incremental /Absolute encoder(17 bits)									
Allowable radial load	N	68		245		392		490		686	
Allowable thrust load	N	58		98		147		196			
Approx. mass	kg (without brake)	0.3	0.5	0.8	1.2	2.3	4.5	5.1	6.8	8.5	
	kg (with brake)	0.5	0.7	1.3	1.7	3.1	5.1	6.5	8.7	10.1	10
Brake specifications	Rated voltage	24 VDC +/-5%						24 VDC +/-10%			
	Holding brake moment of inertia J	0.002		0.018		0.075	0.25	0.33	1.35		
	Power consumption (at 20°C)	W	7		9		10	18	19	14	19
	Current consumption (at 20°C)	A	0.3		0.36		0.42	0.74	0.81	0.59	0.79
	Static friction torque	N·m (minimum)	0.29		1.27		2.45	4.9	7.8	4.9	13.7
	Rise time for holding torque	ms (max.)	35		50		70	50		80	100
Release time	ms (max)	20		15		20	15		70	50	
Basic specifications	Rating	Continuous									
	Insulation grade	Type B						Type F			
	Ambient operating/ storage temperature	0 to +40°C/ -20 to 65°C						0 to +40°C/ -20 to 80°C			
	Ambient operating/ storage humidity	85% RH max. (non-condensing)									
	Vibration class	V-15									
	Insulation resistance	20 MΩ min. at 500 VDC between the power terminals and FG terminal									
	Enclosure	Totally-enclosed, self-cooling, IP65 (excluding shaft opening and lead wire ends)									
	Vibration resistance	Vibration acceleration 49 m/s ²						Vibration acceleration 24.5 m/s ²			
Mounting	Flange-mounted										

Torque-speed characteristics

R88M-G05030H/T (50 W)

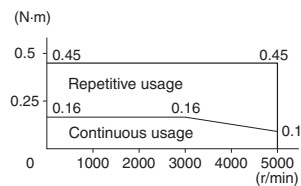

R88M-G10030H/T (100 W)

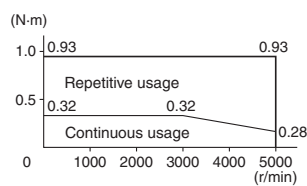

R88M-G20030H/T (200 W)

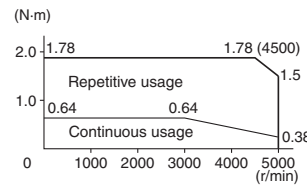

R88M-G40030H/T (400 W)

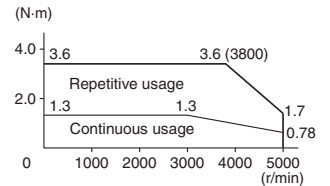

R88M-G75030H/T (750 W)

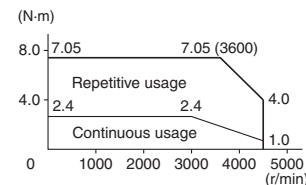

R88M-G1K030T (1 kW)

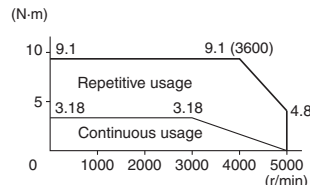

R88M-G1K530T (1.5 kW)

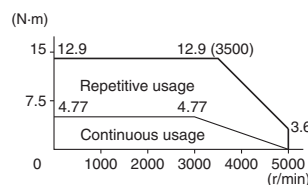

R88M-G1K020T (1 kW)

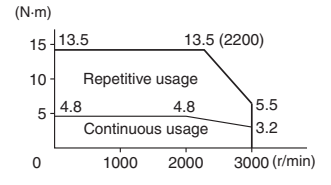

R88M-G1K520T (1.5 kW)

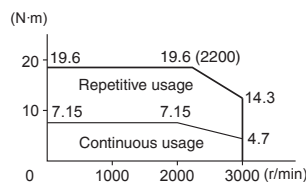

R88M-G90010T (900 W)

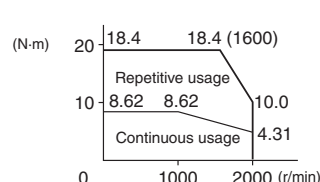

Flat servo motors 3000 r/min

Ratings and specifications

Applied voltage		230 V		
Servo motor model R88M-□		GP10030□	GP20030□	GP40030□
Rated output	W	100	200	400
Rated torque	N·m	0.32	0.64	1.3
Instantaneous peak torque	N·m	0.86	1.8	3.65
Rated current	A (rms)	1	1.6	2.5
Instantaneous max. current	A (rms)	3.1	4.9	7.5
Rated speed	min ⁻¹	3000		
Max. speed	min ⁻¹	5000		
Torque constant	N·m/A (rms)	0.34	0.42	0.54
Rotor moment of inertia (JM)	kg·m ² ×10 ⁻⁴	0.1	0.35	0.64
Allowable load moment of inertia (JL)	Multiple of (JM)	20		
Rated power rate	kW/s	10.2	11.5	25.5
Applicable encoder		Incremental (10000 pulses)		
		Incremental /Absolute encoder(17 bits)		
Allowable radial load	N	68	245	
Allowable thrust load	N	58	98	
Approx. mass	kg (without brake)	0.7	1.3	1.8
	kg (with brake)	0.9	2	2.5
Brake specifications	Rated voltage	24VDC +/-10%		
	Holding brake moment of inertia J	kg·m ² ×10 ⁻⁴	0.03	0.09
	Power consumption (at 20°C)	W	7	10
	Current consumption (at 20°C)	A	0.29	0.41
	Static friction torque	N·m (minimum)	0.29	1.27
	Rise time for holding torque	ms (max.)	50	60
	Release time	ms (max)	15	
Basic specifications	Rating	Continuous		
	Insulation grade	Type B		
	Ambient operating/ storage temperature	0 to +40 °C/ -20 to 80°C		
	Ambient operating/ storage humidity	85% RH max. (non-condensing)		
	Vibration class	V-15		
	Insulation resistance	20 MΩ min. at 500 VDC between the power terminals and FG terminal		
	Enclosure	Totally-enclosed, self-cooling, IP65 (excluding shaft opening and lead wire ends)		
	Vibration resistance	Vibration acceleration 49 m/s ²		
Mounting	Flange-mounted			

Torque-speed characteristics

R88M-GP10030H/T (100 W)

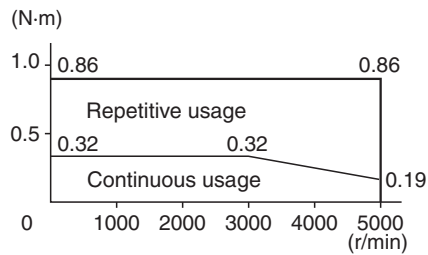

R88M-GP20030H/T (200 W)

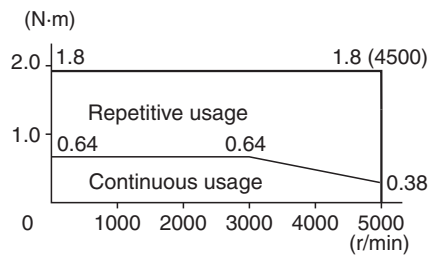

R88M-GP40030H/T (400 W)

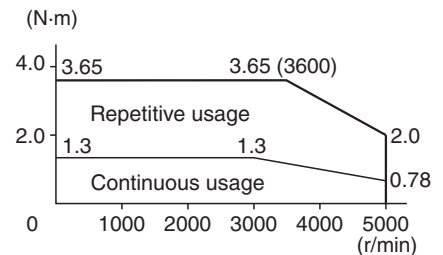

Dimensions

Servo motors

Cylindrical type 3000 r/min (230 V, 50-100 W)

Dimensions (mm)	Without brake	With brake	LN	Flange surface			Shaft end		Aprox. mass (kg)	
				D	S	B	Without brake	With brake		
R88M-G05030□-□S2	72	102	26.5	30 ^{h7}	8 ^{h6}	3 ^{h9}	0.3		0.5	
R88M-G10030□-□S2	92	122	46.5				0.5		0.7	

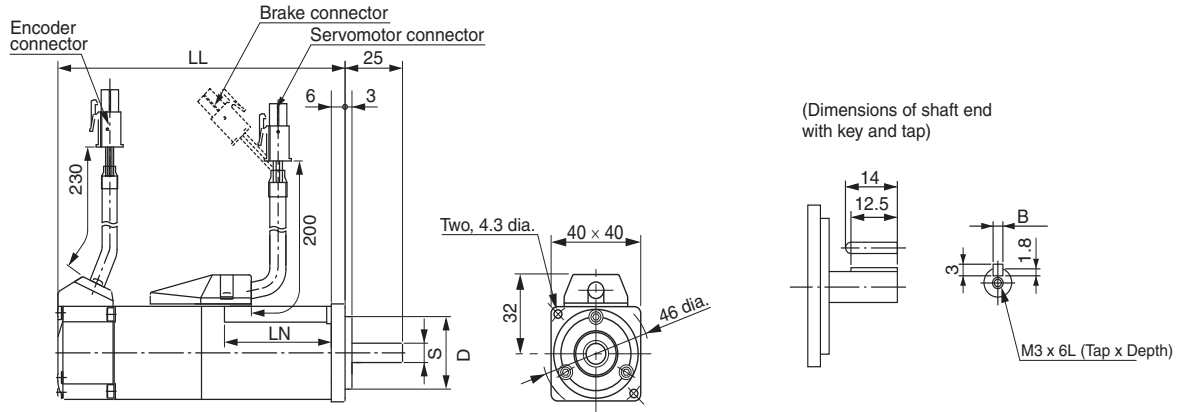

Cylindrical type 3000 r/min (230 V, 200-750 W)

Dimensions (mm)	Without brake	With brake	LR	KL1	Flange surface					Shaft end					Aprox. mass (kg)		
					D1	D2	C	G	Z	S	QK	B	H	T1	Tap x depth	Without brake	With brake
R88M-G20030□-□S2	79.5	116	30	43	70	50 ^{h7}	60	6.5	4.5	11 ^{h6}	18	4 ^{h9}	4	2.5	M4x8L	0.8	1.3
R88M-G40030□-□S2	99	135.5								14 ^{h6}	22.5	5 ^{h9}	5	3	M5x10L	1.2	1.7
R88M-G75030□-□S2	112.2	149.2	35	53	90	70 ^{h7}	80	8	6	19 ^{h6}	22	6 ^{h9}	6	3.5		2.3	3.1

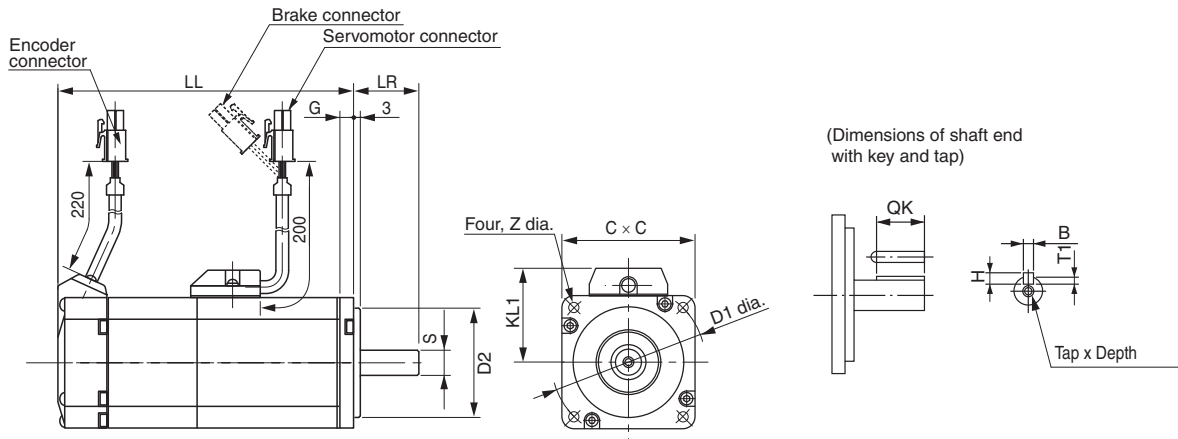

Cylindrical type 3000, 2000 and 1000 r/min (230 V, 900 kW - 1.5 kW)

Dimensions (mm)	Without brake	With brake	LR	KL1	Flange surface								Shaft end					Aprox. mass (kg)		
					Model	LL	LL	D1	D2	D3	C	G	F	Z	S	QK	B	H	T1	Tap x depth
R88M-G1K030T-□S2	175	200	55	98	100	80 ^{h7}	120	90	7	3	6.6	19 ^{h6}	42	6 ^{h9}	6	3.5	M5x12L	4.5	5.1	
R88M-G1K530T-□S2	180	205		103	115	95 ^{h7}	135	100	10		9								5.1	6.5
R88M-G1K020T-□S2	150	175		118	145	110 ^{h7}	165	130	12	6		22 ^{h6}	41	8 ^{h9}	7	4			6.8	8.7
R88M-G1K520T-□S2	175	200																	8.5	10.1
R88M-G90010T-□S2	175	200	70																10	

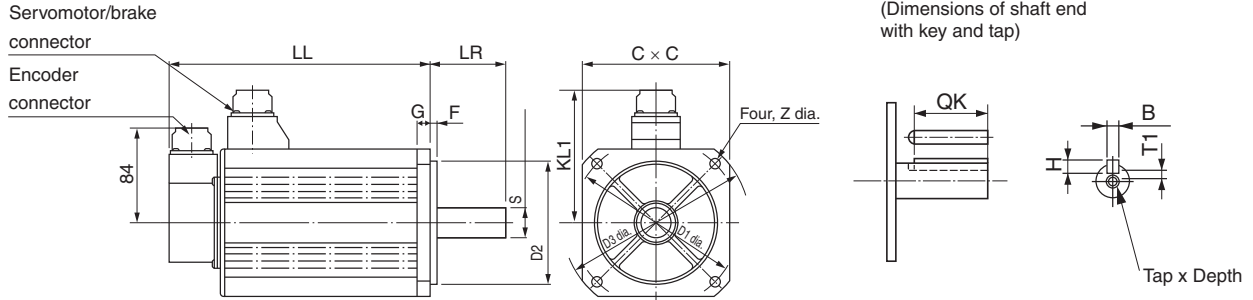

Flat type 3000 r/min (230 V, 100 W - 400 W)

Dimensions (mm)	Without brake	With brake	LR	KL1	Flange surface								Shaft end					Aprox. mass (kg)		
					Model	LL	LL	D1	D2	C	F	G	Z	S	QK	B	H	T1	Tap x depth	Without brake
R88M-GP10030H-□S2	60.5	84.5	25	43	70	50 ^{h7}	60	3	7	4.5	8 ^{h6}	12.5	3 ^{h9}	3	1.8	M3x6L	0.7	0.9		
R88M-GP10030T-□S2	87.5	111.5																		
R88M-GP20030H-□S2	67.5	100	30	53	90	70 ^{h7}	80	5	8	5.5	11 ^{h6}	18	4 ^{h9}	4	2.5	M4x8L	1.3	2		
R88M-GP20030T-□S2	94.5	127																		
R88M-GP40030H-□S2	82.5	115											14 ^{h6}	22.5	5 ^{h9}	5	3.0	M5x10L	1.8	2.5
R88M-GP40030T-□S2	109.5	142																		

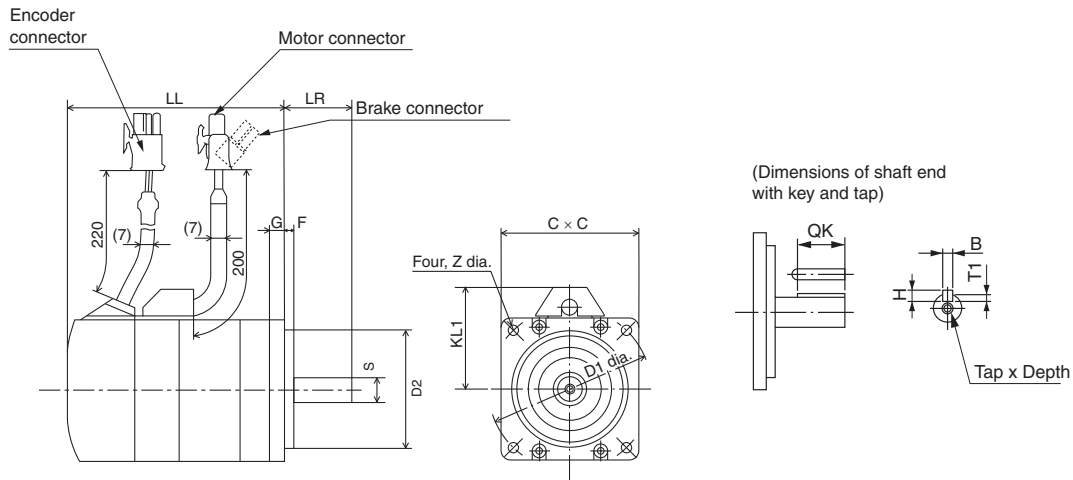

Ordering information

① G-Series Cylindrical type Servo motor

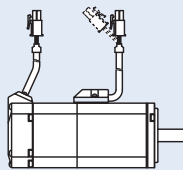

3000 rpm (50-750W)

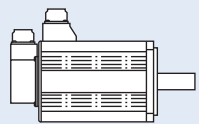

3000 rpm (1000-1500 W)
2000 rpm (1000-1500 W)
1000 rpm (900 W)

① G-Series Flat type Servo motor

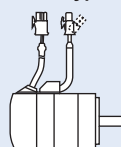

3000 rpm (100-400 W)

(Refer to servo drive chapter)

Drive options

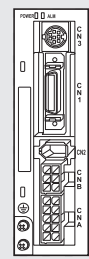

② SmartStep 2
Servo drive controlled by pulses

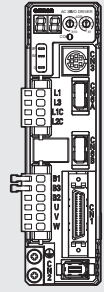

② G-Series Servo drive
ML2 and Analogue/ pulse models

③ Encoder cable

④ Absolute Encoder Battery cable

⑤ Power cable

⑥ Brake cable

Note: The symbols ①②③④⑤⑥... show the recommended sequence to select the servo motor and cables



Servo motor

① Select motor from Cylindrical and Flat types using motor tables in next pages.

Servo drive

② Refer to G-Series and SmartStep2 servo drive chapters for detailed drive specifications and selection of drive accessories.



Cylindrical servo motors 3000/2000/1000 r/min (50 - 1.5 kW)

Symbol	Specifications						Servo motor model	Compatible servo drives ②	
	Voltage	Encoder and design	Speed	Design	Rated torque	Capacity		SmartStep2	G-Series
 <p>(50-750 W)</p>  <p>(900-1500 W)</p>	230 V	Incremental encoder (10000 pulses) Straight shaft with key & tap	3000 min ⁻¹	Without brake	0.16 Nm	50 W	R88M-G05030H-S2	R7D-BP01H	R88D-G□01H□
					0.32 Nm	100 W	R88M-G10030H-S2	R7D-BP01H	R88D-G□01H□
					0.64 Nm	200 W	R88M-G20030H-S2	R7D-BP02HH	R88D-G□02H□
					1.3 Nm	400 W	R88M-G40030H-S2	R7D-BP04H	R88D-G□04H□
					2.4 Nm	750 W	R88M-G75030H-S2	R88D-GP08H	R88D-G□08H□
					0.16 Nm	50 W	R88M-G05030H-BS2	R7D-BP01H	R88D-G□01H□
				0.32 Nm	100 W	R88M-G10030H-BS2	R7D-BP01H	R88D-G□01H□	
				0.64 Nm	200 W	R88M-G20030H-BS2	R7D-BP02HH	R88D-G□02H□	
				1.3 Nm	400 W	R88M-G40030H-BS2	R7D-BP04H	R88D-G□04H□	
				2.4 Nm	750 W	R88M-G75030H-BS2	R88D-GP08H	R88D-G□08H□	
				0.16 Nm	50 W	R88M-G05030T-S2	-	R88D-G□01H□	
				0.32 Nm	100 W	R88M-G10030T-S2	-	R88D-G□01H□	
		0.64 Nm	200 W	R88M-G20030T-S2	-	R88D-G□02H□			
		1.3 Nm	400 W	R88M-G40030T-S2	-	R88D-G□04H□			
		2.4 Nm	750 W	R88M-G75030T-S2	-	R88D-G□08H□			
		3.18 Nm	1 kW	R88M-G1K030T-S2	-	R88D-G□15H□			
		4.77 Nm	1.5 kW	R88M-G1K530T-S2	-	R88D-G□15H□			
		0.16 Nm	50 W	R88M-G05030T-BS2	-	R88D-G□01H□			
		0.32 Nm	100 W	R88M-G10030T-BS2	-	R88D-G□01H□			
		0.64 Nm	200 W	R88M-G20030T-BS2	-	R88D-G□02H□			
		1.3 Nm	400 W	R88M-G40030T-BS2	-	R88D-G□04H□			
		2.4 Nm	750 W	R88M-G75030T-BS2	-	R88D-G□08H□			
		3.18 Nm	1 kW	R88M-G1K030T-BS2	-	R88D-G□15H□			
		4.77 Nm	1.5 kW	R88M-G1K530T-BS2	-	R88D-G□15H□			
2000 min ⁻¹	Absolute/ incremental encoder (17 bits) Straight shaft with key & tap	Without brake	With brake	4.8 Nm	1 kW	R88M-G1K020T-S2	-	R88D-G□10H□	
				7.15 Nm	1.5 kW	R88M-G1K520T-S2	-	R88D-G□15H□	
				4.8 Nm	1 kW	R88M-G1K020T-BS2	-	R88D-G□10H□	
		7.15 Nm	1.5 kW	R88M-G1K520T-BS2	-	R88D-G□15H□			
		1000 min ⁻¹	Without brake	8.62 Nm	900 W	R88M-G90010T-S2	-	R88D-G□15H□	
						R88M-G90010T-BS2	-	R88D-G□15H□	

Flat type servo motors 3000 r/min (100 - 400 W)

Symbol	Specifications				Servo motor model	Compatible servo drives (2)			
	Voltage	Encoder and design		Rated torque		Capacity	SmartStep2	G-Series	
① 	230 V	Incremental encoder (10000 pulses)	Without brake	0.32 Nm	100 W	R88M-GP10030H-S2	R7D-BP01H	R88D-G□01H□	
				0.64 Nm	200 W	R88M-GP20030H-S2	R7D-BP02HH	R88D-G□02H□	
				1.3 Nm	400 W	R88M-GP40030H-S2	R7D-BP04H	R88D-G□04H□	
			With brake	0.32 Nm	100 W	R88M-GP10030H-BS2	R7D-BP01H	R88D-G□01H□	
				0.64 Nm	200 W	R88M-GP20030H-BS2	R7D-BP02HH	R88D-G□02H□	
				1.3 Nm	400 W	R88M-GP40030H-BS2	R7D-BP04H	R88D-G□04H□	
		Absolute/ incremental encoder (17 bits)	Without brake	Straight shaft with key & tap	0.32 Nm	100 W	R88M-GP10030T-S2	-	R88D-G□01H□
					0.64 Nm	200 W	R88M-GP20030T-S2	-	R88D-G□02H□
					1.3 Nm	400 W	R88M-GP40030T-S2	-	R88D-G□04H□
			With brake		0.32 Nm	100 W	R88M-GP10030T-BS2	-	R88D-G□01H□
					0.64 Nm	200 W	R88M-GP20030T-BS2	-	R88D-G□02H□
					1.3 Nm	400 W	R88M-GP40030T-BS2	-	R88D-G□04H□

Encoder cables

Symbol	Specifications	Model	Appearance
③	Encoder cable for absolute encoder (50-750 W) R88M-G(50/100/200/400/750)30T-□ R88M-GP(100/200/400)30T-□	1.5 m R88A-CRGA001-5CR-E	
		3 m R88A-CRGA003CR-E	
		5 m R88A-CRGA005CR-E	
		10 m R88A-CRGA010CR-E	
		15 m R88A-CRGA015CR-E	
		20 m R88A-CRGA020CR-E	
	Encoder cable for Incremental encoder (50-750 W) R88M-G(50/100/200/400/750)30H-□ R88M-GP(100/200/400)30H-□	1.5 m R88A-CRGB001-5CR-E	
		3 m R88A-CRGB003CR-E	
		5 m R88A-CRGB005CR-E	
		10 m R88A-CRGB010CR-E	
		15 m R88A-CRGB015CR-E	
		20 m R88A-CRGB020CR-E	
	Encoder cable for Absolute encoder (900-1500 W) R88M-G(1K0/1K5)30T-□ R88M-G(1K0/1K5)20T-□ R88M-G90010T-□	1.5 m R88A-CRGC001-5NR-E	
		3 m R88A-CRGC003NR-E	
		5 m R88A-CRGC005NR-E	
		10 m R88A-CRGC010NR-E	
		15 m R88A-CRGC015NR-E	
		20 m R88A-CRGC020NR-E	

Absolute encoder battery cable

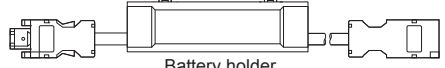
Symbol	Specifications	Model	Appearance	
④	Absolute Encoder battery cable	Battery not included	0.3 m R88A-CRGD0R3C-E	 Battery holder
		Battery included	0.3 m R88A-CRGD0R3C-BS-E	
	Absolute Encoder backup battery 2,000 mA.h 3.6V	-	R88A-BAT01G	

Note: The absolute encoder battery cable is only an extension and must be used with an absolute encoder cable.

Power cables

for SmartStep2 servo drive

Symbol	Specifications	Model	Appearance	
⑤	For servomotors from 50 to 400 W R88M-G(50/100/200/400)30□ R88M-GP(100/200/400)30□ For servomotors with brake, a separate cable (R88A-CAGA□BR-E) is needed	1.5 m	R7A-CAB001-5SR-E	
		3 m	R7A-CAB003SR-E	
		5 m	R7A-CAB005SR-E	
		10 m	R7A-CAB010SR-E	
		15 m	R7A-CAB015SR-E	
		20 m	R7A-CAB020SR-E	
	For servomotors 750W R88M-G75030□ For servomotors with brake, a separate cable (R88A-CAGA□BR-E) is needed	1.5 m	R88A-CAGA001-5SR-E	
		3 m	R88A-CAGA003SR-E	
		5 m	R88A-CAGA005SR-E	
		10 m	R88A-CAGA010SR-E	
15 m		R88A-CAGA015SR-E		
20 m		R88A-CAGA020SR-E		

for G-Series servo drive

Symbol	Specifications	Model	Appearance	
⑤	For servomotors from 50 to 750W R88M-G(50/100/200/400/750)30□ R88M-GP(100/200/400)30□ For servomotors with brake, a separate cable (R88A-CAGA□BR-E) is needed	1.5 m	R88A-CAGA001-5SR-E	
		3 m	R88A-CAGA003SR-E	
		5 m	R88A-CAGA005SR-E	
		10 m	R88A-CAGA010SR-E	
		15 m	R88A-CAGA015SR-E	
		20 m	R88A-CAGA020SR-E	
	For servomotors from 900 to 1.5 kW without brake R88M-G(1K0/1K5)30T-S2 R88M-G(1K0/1K5)20T-S2 R88M-G90010T-S2	1.5 m	R88A-CAGB001-5SR-E	
		3 m	R88A-CAGB003SR-E	
		5 m	R88A-CAGB005SR-E	
		10 m	R88A-CAGB010SR-E	
15 m		R88A-CAGB015SR-E		
20 m		R88A-CAGB020SR-E		
For servomotors from 900 to 1.5 kW with brake R88M-G(1K0/1K5)30T-BS2 R88M-G(1K0/1K5)20T-BS2 R88M-G90010T-BS2	1.5 m	R88A-CAGB001-5BR-E		
	3 m	R88A-CAGB003BR-E		
	5 m	R88A-CAGB005BR-E		
	10 m	R88A-CAGB010BR-E		
	15 m	R88A-CAGB015BR-E		
	20 m	R88A-CAGB020BR-E		

Brake cable (for 50-750W servomotors)

Symbol	Specifications	Model	Appearance	
⑥	Brake cable only. For servomotors from 50 to 750W with brake R88M-G(050/100/200/400/750)30□-BS2, R88M-GP(100/200/400)30□-BS2	1.5 m	R88A-CAGA001-5BR-E	
		3 m	R88A-CAGA003BR-E	
		5 m	R88A-CAGA005BR-E	
		10 m	R88A-CAGA010BR-E	
		15 m	R88A-CAGA015BR-E	
		20 m	R88A-CAGA020BR-E	

Connectors for power, encoder and brake cables

Specifications	Applicable Servomotor	Model	
Connectors for power cables	Drive side (CNB)	R88M-G(050/100/200/400)30H□, R88M-GP(100/200/400)30H□ (SmartStep2 Servo drives only)	R7A-CNB01A
	Motor side	R88M-G(050/100/200/400/750)30□, R88M-GP(100/200/400)30□	R88A-CNG01A
	Motor side	R88M-G(1K0/1K5)30□-S2, R88M-G(1K0/1K5)20□-S2, R88M-G90010□-S2 (without brake)	MS3108E20-4S
	Motor side	R88M-G(1K0/1K5)30□-BS2, R88M-G(1K0/1K5)20□-BS2, R88M-G90010□-BS2 (with brake)	MS3108E20-18S
Connectors for encoder cables	Drive side (CN2)	-	R88A-CNW01R
	Motor side	R88M-G(050/100/200/400/750)30T-□, R88M-GP(100/200/400)30T-□ (Absolute encoder)	R88A-CNG01R
	Motor side	R88M-G(050/100/200/400/750)30H-□, R88M-GP(100/200/400)30H-□ (Incremental encoder)	R88A-CNG02R
Motor side	R88M-G(1K0/1K5)30T-□, R88M-G(1K0/1K5)20T-□, R88M-G90010T-□	MS3108E20-29S	
Connector for brake cable	Motor side	R88M-G(050/100/200/400/750)30□-BS2, R88M-GP(100/200/400)30□-BS2	R88A-CNG01B

- Note:** 1. All cables listed are flexible and shielded (except the R88A-CAGA□□□BR-E which is only a flexible cable)
 2. The R88A-CRGC□□□NR-E, R88A-CAGB□□□SR-E and R88A-CAGB□□□BR-E cables have IP67 class (including connector)

ALL DIMENSIONS SHOWN ARE IN MILLIMETERS.
To convert millimeters into inches, multiply by 0.03937. To convert grams into ounces, multiply by 0.03527.

R88L-EC-FW/GW-□

Accurax linear motor

New linear motors with optimised efficiency

Iron-core motors for high speed and high duty cycle operations and Ironless motors for cogging-free and high dynamic applications. Both motor and families deliver unparalleled accuracy and performance benefits.

- Ironless and iron-core types available
- High dynamic and precise positioning
- Compact and flat design iron-core motors
- Excellent force-to-weight ratio ironless motors
- Weight-optimised magnet track
- Optional digital hall-sensor and connectors
- Temperature sensors included

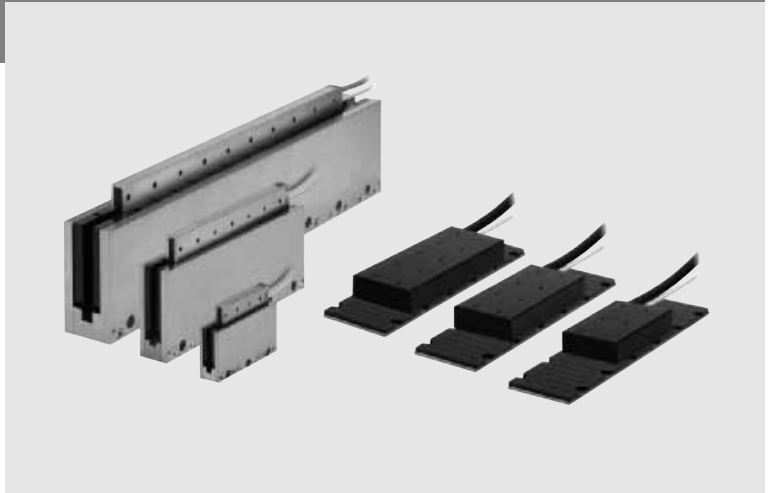

Ratings

- Iron-core motors - 48 to 760 N (2000 N peak force)
- Ironless motor - 26.5 to 348 N (2100 N peak force)

System configuration

(Refer to servo drive chapter)

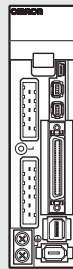

Accurax G5 servo drive
Analogue/ Pulse and EtherCAT models

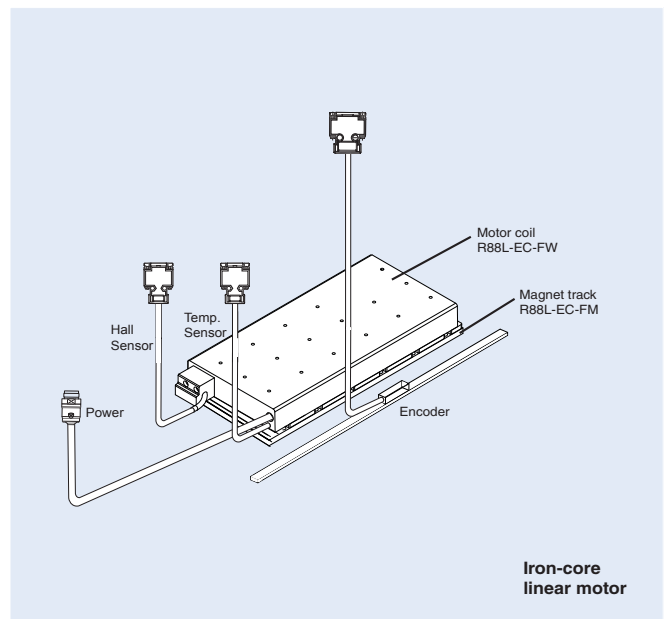
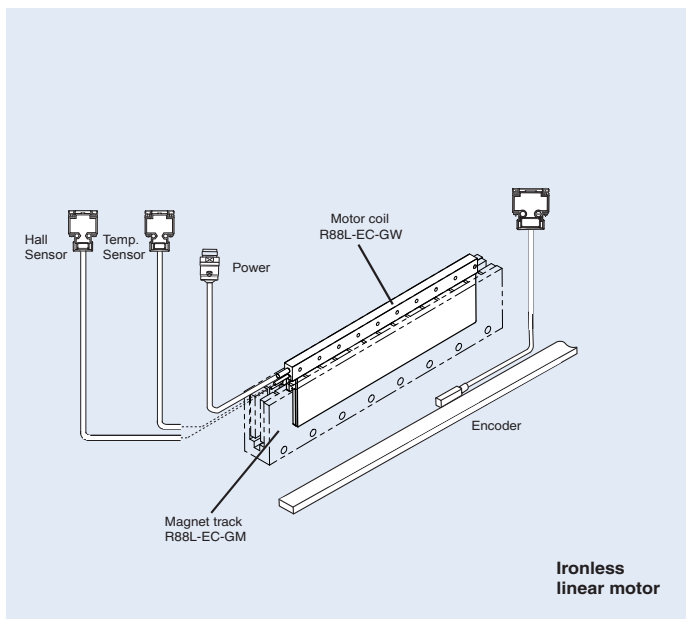

Linear Motor / Servo Drive combination

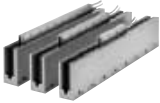
Linear motor coil				Linear Servo drive				
Type	Rated force	Peak force	Model	Accurax G5 EtherCAT model		Accurax G5 Analog/pulse model		
				230V	400V	230V	400V	
R88L-EC-FW-□ Iron-core motors  230V / 400V	48 N	105 N	Coil without connectors	R88L-EC-FW-0303-ANPC	R88D-KN02H-ECT-L	R88D-KN06F-ECT-L	R88D-KT02H-L	R88D-KT06F-L
	96 N	210 N		R88L-EC-FW-0306-ANPC	R88D-KN04H-ECT-L	R88D-KN10F-ECT-L	R88D-KT04H-L	R88D-KT10F-L
	160 N	400 N		R88L-EC-FW-0606-ANPC	R88D-KN08H-ECT-L	R88D-KN15F-ECT-L	R88D-KT08H-L	R88D-KT15F-L
	240 N	600 N		R88L-EC-FW-0609-ANPC	R88D-KN10H-ECT-L	R88D-KN20F-ECT-L	R88D-KT10H-L	R88D-KT20F-L
	320 N	800 N		R88L-EC-FW-0612-ANPC	R88D-KN15H-ECT-L	R88D-KN30F-ECT-L	R88D-KT15H-L	R88D-KT30F-L
	608 N	1600 N		R88L-EC-FW-1112-ANPC	R88D-KN15H-ECT-L	R88D-KN30F-ECT-L	R88D-KT15H-L	R88D-KT30F-L
	760 N	2000 N		R88L-EC-FW-1115-ANPC	R88D-KN15H-ECT-L	R88D-KN30F-ECT-L	R88D-KT15H-L	R88D-KT30F-L
	48 N	105 N	Coil with connectors	R88L-EC-FW-0303-APLC	R88D-KN02H-ECT-L	R88D-KN06F-ECT-L	R88D-KT02H-L	R88D-KT06F-L
	96 N	210 N		R88L-EC-FW-0306-APLC	R88D-KN04H-ECT-L	R88D-KN10F-ECT-L	R88D-KT04H-L	R88D-KT10F-L
	160 N	400 N		R88L-EC-FW-0606-APLC	R88D-KN08H-ECT-L	R88D-KN15F-ECT-L	R88D-KT08H-L	R88D-KT15F-L
	240 N	600 N		R88L-EC-FW-0609-APLC	R88D-KN10H-ECT-L	R88D-KN20F-ECT-L	R88D-KT10H-L	R88D-KT20F-L
	320 N	800 N		R88L-EC-FW-0612-APLC	R88D-KN15H-ECT-L	R88D-KN30F-ECT-L	R88D-KT15H-L	R88D-KT30F-L
	608 N	1600 N		R88L-EC-FW-1112-APLC	R88D-KN15H-ECT-L	R88D-KN30F-ECT-L	R88D-KT15H-L	R88D-KT30F-L
	760 N	2000 N		R88L-EC-FW-1115-APLC	R88D-KN15H-ECT-L	R88D-KN30F-ECT-L	R88D-KT15H-L	R88D-KT30F-L
R88L-EC-GW-□ Ironless motors  230V	26.5N	100 N	Coil without connectors	R88L-EC-GW-0303-ANPS	R88D-KN02H-ECT-L	-	R88D-KT02H-L	-
	53 N	200 N		R88L-EC-GW-0306-ANPS	R88D-KN08H-ECT-L	-	R88D-KT08H-L	-
	80 N	300 N		R88L-EC-GW-0309-ANPS	R88D-KN10H-ECT-L	-	R88D-KT10H-L	-
	58 N	240 N		R88L-EC-GW-0503-ANPS	R88D-KN02H-ECT-L	-	R88D-KT02H-L	-
	117 N	480 N		R88L-EC-GW-0506-ANPS	R88D-KN04H-ECT-L	-	R88D-KT04H-L	-
	175 N	720 N		R88L-EC-GW-0509-ANPS	R88D-KN08H-ECT-L	-	R88D-KT08H-L	-
	117 N	700 N		R88L-EC-GW-0703-ANPS	R88D-KN04H-ECT-L	-	R88D-KT04H-L	-
	232 N	1400 N		R88L-EC-GW-0706-ANPS	R88D-KN08H-ECT-L	-	R88D-KT08H-L	-
	348 N	2100 N		R88L-EC-GW-0709-ANPS	R88D-KN10H-ECT-L	-	R88D-KT10H-L	-
	26.5N	100 N	Coil with connectors	R88L-EC-GW-0303-APLS	R88D-KN02H-ECT-L	-	R88D-KT02H-L	-
	53 N	200 N		R88L-EC-GW-0306-APLS	R88D-KN08H-ECT-L	-	R88D-KT08H-L	-
	80 N	300 N		R88L-EC-GW-0309-APLS	R88D-KN10H-ECT-L	-	R88D-KT10H-L	-
	58 N	240 N		R88L-EC-GW-0503-APLS	R88D-KN02H-ECT-L	-	R88D-KT02H-L	-
	117 N	480 N		R88L-EC-GW-0506-APLS	R88D-KN04H-ECT-L	-	R88D-KT04H-L	-
	175 N	720 N		R88L-EC-GW-0509-APLS	R88D-KN08H-ECT-L	-	R88D-KT08H-L	-
	117 N	700 N		R88L-EC-GW-0703-APLS	R88D-KN04H-ECT-L	-	R88D-KT04H-L	-
	232 N	1400 N		R88L-EC-GW-0706-APLS	R88D-KN08H-ECT-L	-	R88D-KT08H-L	-
	348 N	2100 N		R88L-EC-GW-0709-APLS	R88D-KN10H-ECT-L	-	R88D-KT10H-L	-

Type designation

Linear motor coil

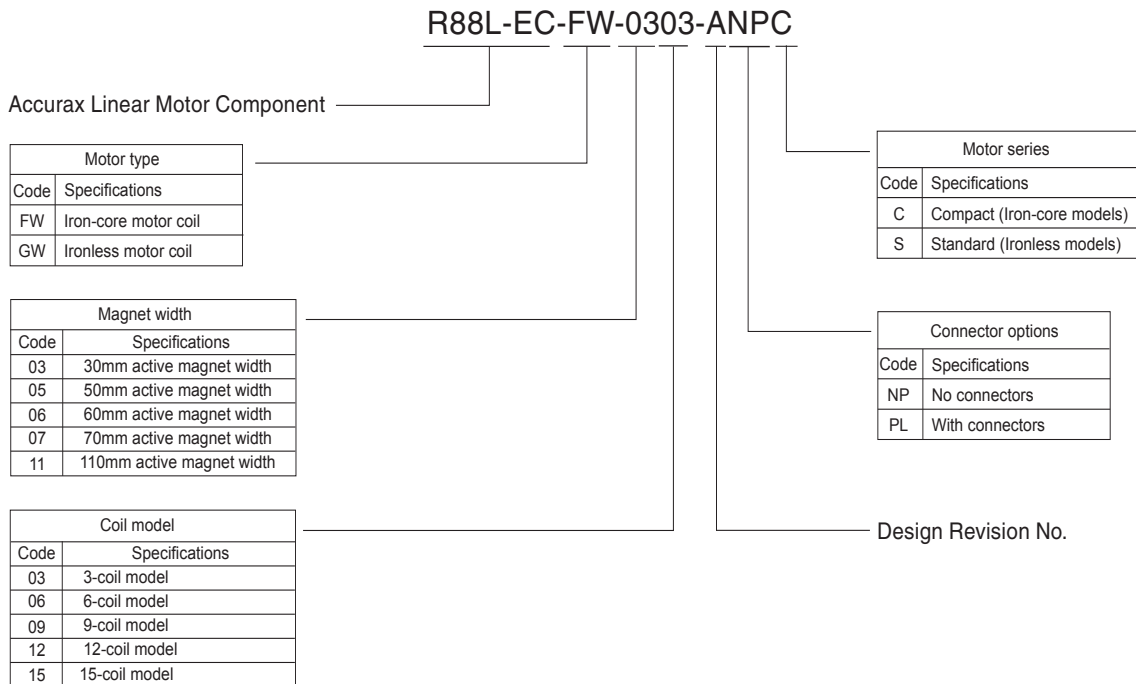

Magnet track

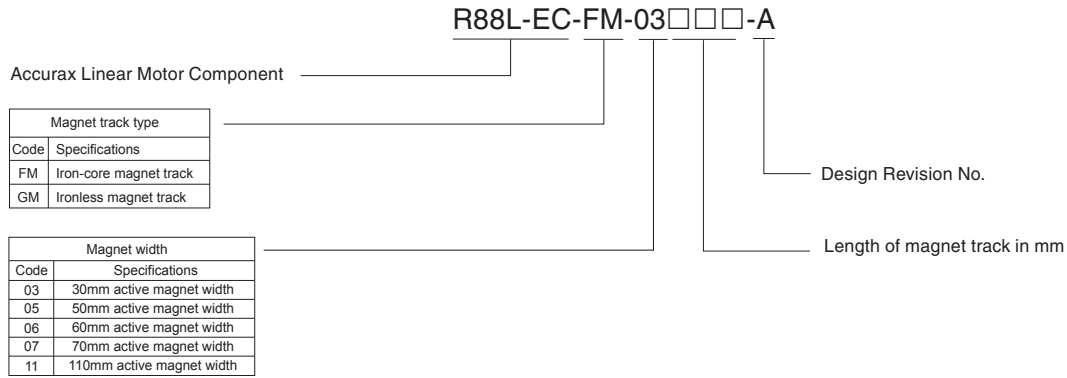

Hall Sensor

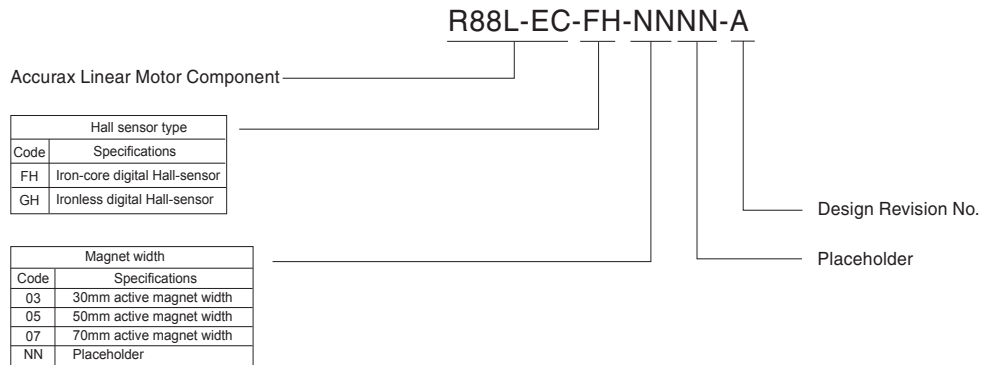

Linear servo motor specifications

Iron-core motors R88L-EC-FW-□ (230/400 VAC)

Voltage	230/400V							
	R88L-EC-FW-□	0303-□	0306-□	0606-□	0609-□	0612-□	1112-□	1115-□
Linear motor model	R88L-EC-FW-□	0303-□	0306-□	0606-□	0609-□	0612-□	1112-□	1115-□
Maximum speed (100V)	m/s	2,5		2			1	
Maximum speed (200V)	m/s	5		4			2	
Maximum speed (400V)	m/s	10		8			4	
Peak force ^{*1}	N	105	210	400	600	800	1600	2000
Peak current ^{*1}	Arms	3.1	6.1	10	15	20	20	25
Continuous force ^{*2}	N	48	96	160	240	320	608	760
Continuous current ^{*2}	Arms	1.24	2.4	3.4	5.2	6.9	6.5	8.2
Motor force constant	N / Arms	39.7		46.5			93	
BEMF	VDC/m/s	32		38			76	
Motor constant	N / √w	9.75	13.78	19.49	23.87	27.57	41.47	46.37
Phase resistance	Ω	5.34	2.68	1.83	1.23	0.92	1.6	1.29
Phase Inductance	mH	34.7	17.4	13.7	9.2	6.9	12.8	10.3
Electrical time constant	ms	6,5		7,5			8	
Max. cont. power disipation (all coils)	W	32	63	88	131	175	279	349
Thermal resistance	K/W	2.20	1.10	0.78	0.52	0.39	0.23	0.18
Thermal time constant	s	110		124			126	
Magnetic attraction force	N	300	500	1020	1420	1820	3640	4440
Magnet pole pitch	mm	24						
Weight coil unit ^{*3}	Kg	0.48	0.78	1.31	1.84	2.37	4.45	5.45
Weight magnet track	Kg/m	2.1		3.8			10.5	
Dimension cooling plate (l x w x h)	mm	238 x 220 x10		250 x 287 x 12			371 x 330 x14	
Protection methods ^{*4}	Temperature sensors (KTY-83/121 & PTC 110C), self cooling							
Hall sensor	Digital (optional)							
Insulation class	Class B							
Max. bus voltage	560 VDC							
Insulation resistance	500 VDC							
Di-electric strength	2750V for 1sec							
Max. allowable coil temperature	130°C							
Ambient humidity	20 bis to 80% (non-condensing)							
Max. allowable magnet temperature	70°C							

^{*1} Coil temperature rising by 6K/s.

^{*2} Values at 100°C coil temperature and magnets at 25°C. Coil unit must be attached to the given cooling plate sizes in the table and an airstream of 2.5 m/s (25°C) has to be applied.

^{*3} Weight without connector and cable.

^{*4} I²t has to be set properly for high current applications.

All other values at 25°C (+/-10%).

Force-speed characteristics

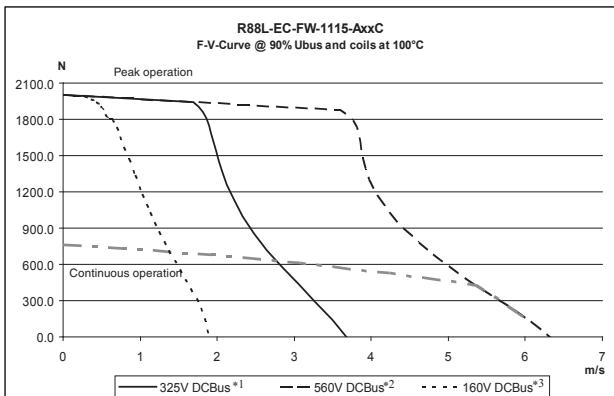
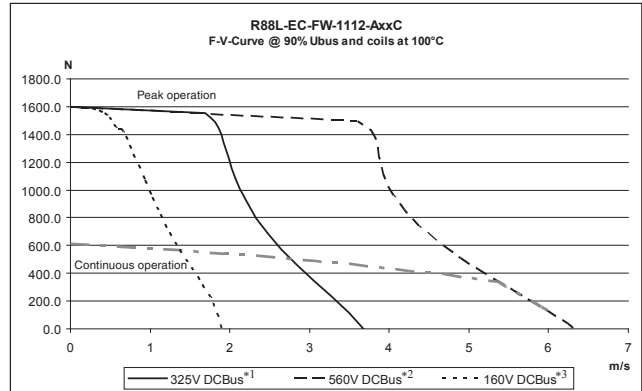
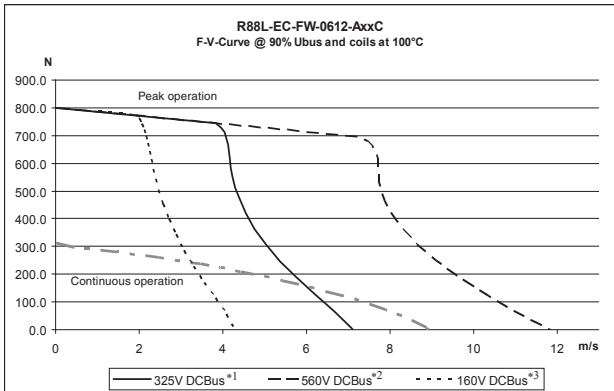
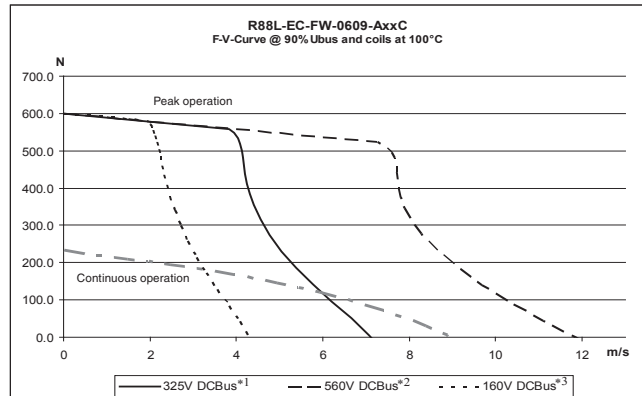
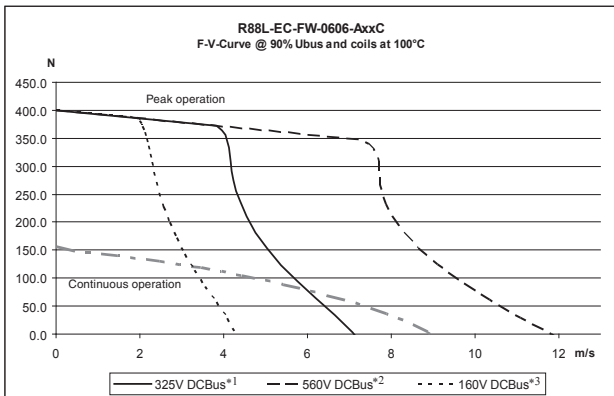
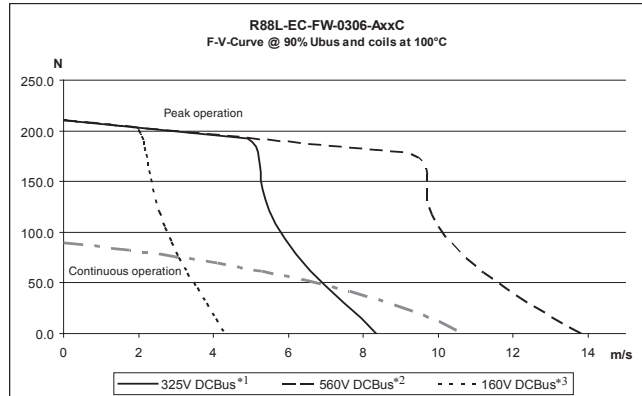
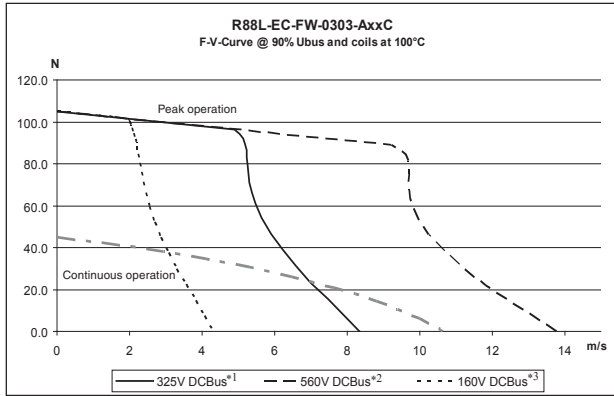

*1 The DCBus voltage corresponds to an AC voltage input (V_{ACIN}) of 235V or more.

*2 The DCBus voltage corresponds to an AC voltage input (V_{ACIN}) of 400V or more.

*3 The DCBus voltage corresponds to an AC voltage input (V_{ACIN}) of 115V or more.

Note: The DCBus value is calculated from the below formula (where is the AV voltage drop in the DC Bus):

$$DCBus = V_{ACIN} \times \sqrt{2} - \Delta V$$

Ironless motors R88L-EC-GW-□ (230 VAC)

Voltage		230V									
Linear motor model	R88L-EC-GW-□	0303-□	0306-□	0309-□	0503-□	0506-□	0509-□	0703-□	0706-□	0709-□	
Maximum speed (100V)	m/s	8			2.2			1.2			
Maximum speed (200V)	m/s	16			4.4			2.4			
Peak force ^{*1}	N	100	200	300	240	480	720	700	1400	2100	
Peak current ^{*1}	Arms	5	10	15	3.5	7.1	10.6	5.6	11.3	16.9	
Continuous force ^{*2}	N	26.5	53	80	58	117	175	117	232	348	
Continuous current ^{*2}	Arms	1.33	2.66	4	0.87	1.76	2.6	0.94	1.87	2.81	
Motor force constant	N / A _{rms}	19.9			68			124			
BEMF	VDC/m/s	16			55.5			101			
Motor constant	N / √W	4.9	6.93	8.43	9.85	13.96	17.03	17.97	25.44	31.14	
Phase resistance	Ω	5.5	2.8	1.8	15.9	8	5.3	15.8	7.9	5.3	
Phase Inductance	mH	1.8	0.9	0.6	13	6.5	4.2	28	14	9	
Electrical time constant	ms	0.35			0.8			1.8			
Max. cont. power disipation (all coils)	W	47	95	142	67	134	200	82	165	247	
Thermal resistance	K/W	2.1	1.06	0.71	1.7	0.85	0.65	1.56	1.04	0.52	
Thermal time constant	s	36			72			96			
Magnetic attraction force	N				0						
Magnet pole pitch	mm	30			42			57			
Weight coil unit ^{*3}	Kg	0.084	0.138	0.198	0.25	0.47	0.69	0.55	0.95	1.35	
Weight magnet track	Kg/m	4.8			11.2			24			
Protection methods ^{*4}	Temperature sensors NTC10k, PTC110C, self cooling										
Hall sensor	Digital (optional)										
Insulation class	Class B										
Max. bus voltage	325 VDC										
Insulation resistance	500 VDC										
Di-electric strength	2250V for 1 sec										
Max. allowable coil temperature	110°C										
Ambient humidity	20-80% non-condensing										
Max. allowable magnet temperature	70°C										

*1 Coil temperature rising 03-series by 40K/s, 05-series by 20K/s and 07-series by 20K/s.

*2 Values at 110°C coil temperature and magnets at 25°C.

*3 Weight without connector and cable.

*4 I²t has to be set properly for high current overload applications.

All other values at 25°C (+/-10%).

Force-speed characteristics

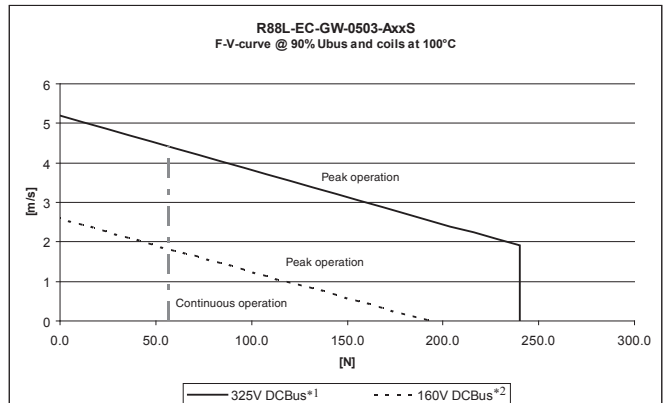
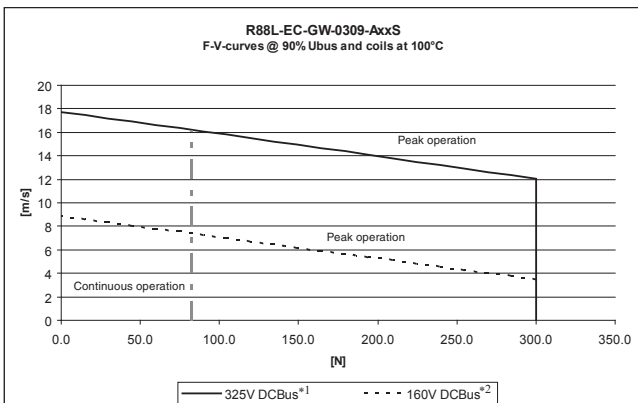
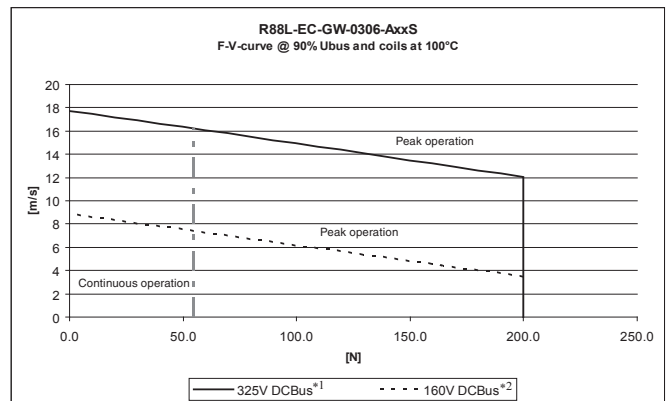
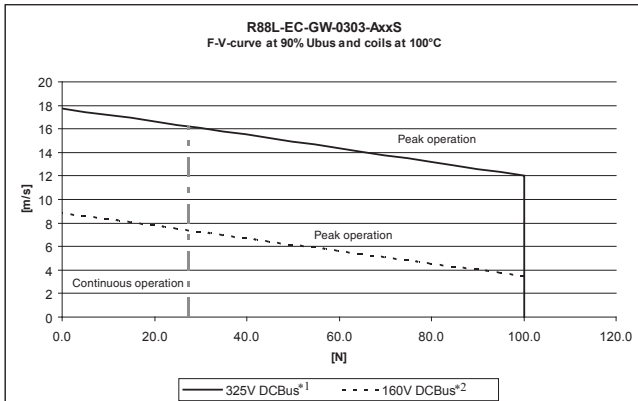

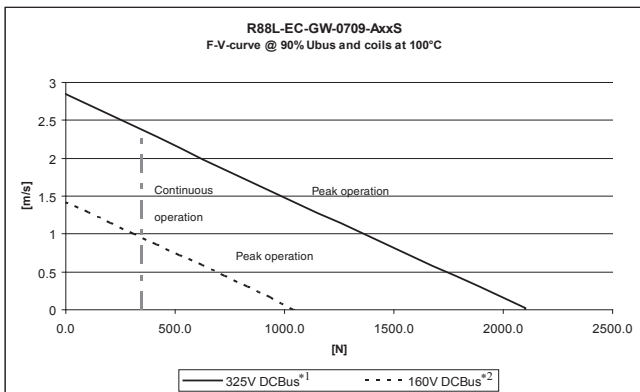
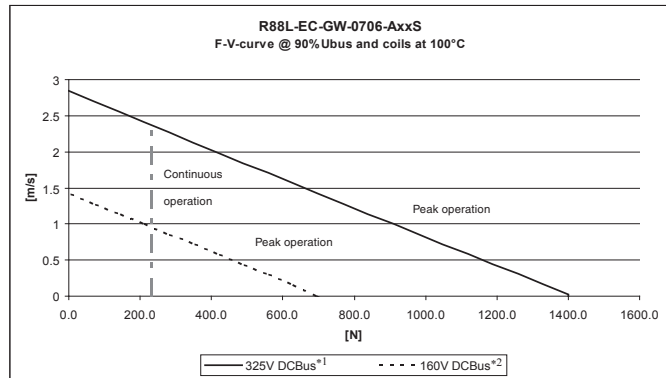
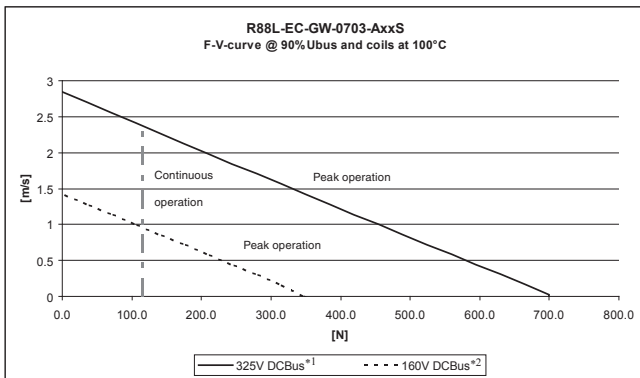
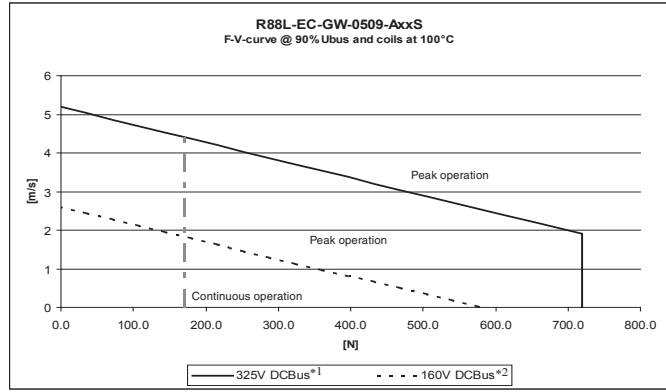
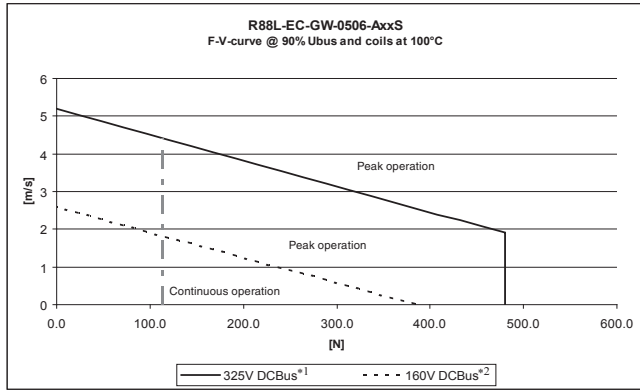

*1 The DCBus voltage corresponds to an AC voltage input (V_{ACIN}) of 235V or more.

*2 The DCBus voltage corresponds to an AC voltage input (V_{ACIN}) of 115V or more.

Note: The DCBus value is calculated from the below formula:

$$DCBus = V_{ACIN} \times \sqrt{2} - \Delta V$$

Dimensions

Iron-core R88L-EC-FW-03

Motor coil

Model	L1 (mm)	L2 (mm)	n
R88L-EC-FW-0303-	105 +/-0.5	79 +0.15/-0.35	1
R88L-EC-FW-0306-	153 +/-0.5	127 +0.15/-0.35	2

Motor coil dimensions with magnet track and hall sensor (optional)

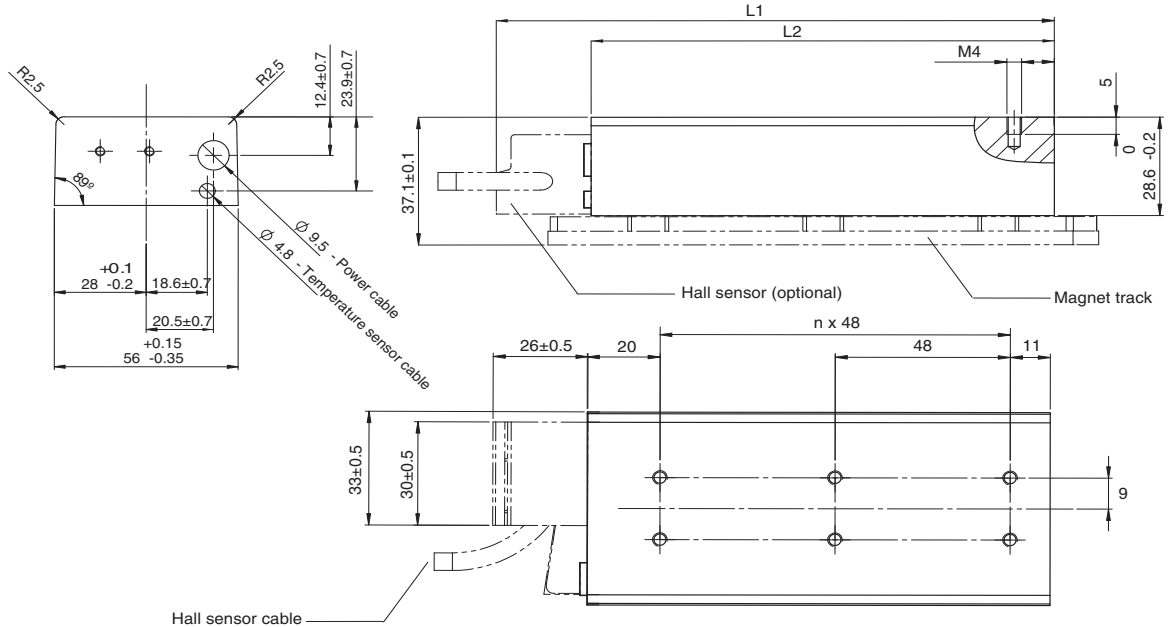

Wiring specifications for motor with connectors

Units: mm



Cable length 500±30
Connector optional
Made by Hypertac
LRRRA06AMRPN182 (MALE)
Pin article code: 021.279.1020

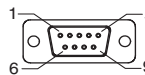

Cable length 500±30
Connector optional
D-Sub 9-pin (MALE)

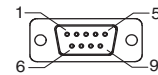

Cable length 500±30
D-Sub 9-pin (MALE)

Power connector		
Pin No.	Wire	Function
1	Black-1	Phase U
2	Black-2	Phase V
3	Green/Yellow	Ground
4	Black-3	Phase W
5	Not used	-
6	Not used	-

Mating connector:
Plug type: LPRA06BFRBN170

Temperature sensor connector		
Pin No.	Wire	Function
1	Not used	-
2	Not used	-
3	Not used	-
4	Not used	-
5	Not used	-
6	White	PTC
7	Brown	PTC
8	Green	KTY
9	Yellow	KTY
Case	Shield	-

Hall sensor connector (optional)		
Pin No.	Wire	Function
1	Brown	5V
2	Grey	Hall U
3	Red	Hall V
4	Yellow	Hall W
5	White	GND
6	Not used	Not used
7	Not used	Not used
8	Not used	Not used
9	Not used	Not used
Case	Shield	-

Magnet track

Model	L1 (mm)	n	Approx. weight (Kg/m)
R88L-EC-FM-03096-A	96	1	2.1
R88L-EC-FM-03144-A	144	2	
R88L-EC-FM-03384-A	384	7	

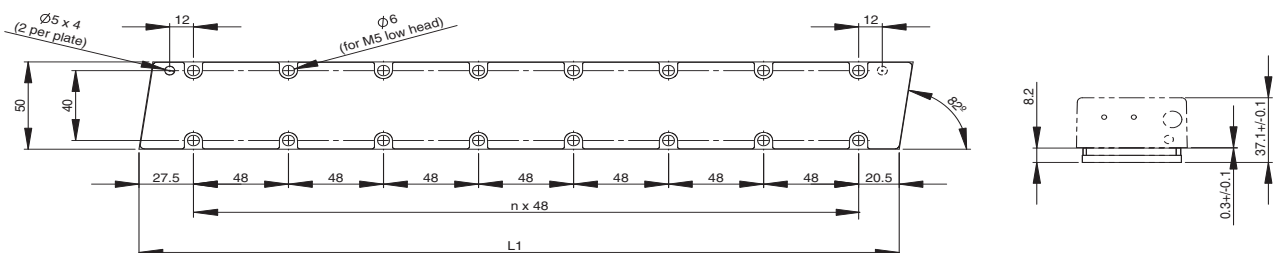

Iron-core R88L-EC-FW-06□

Motor coil

Model	L1 (mm)	L2 (mm)	n
R88L-EC-FW-0606-□	153 +/-0.5	127 +0.15/-0.35	2
R88L-EC-FW-0609-□	201 +/-0.5	175 +0.15/-0.35	3
R88L-EC-FW-0612-□	249 +/-0.5	223 +0.15/-0.35	4

Motor coil dimensions with magnet track and hall sensor (optional)

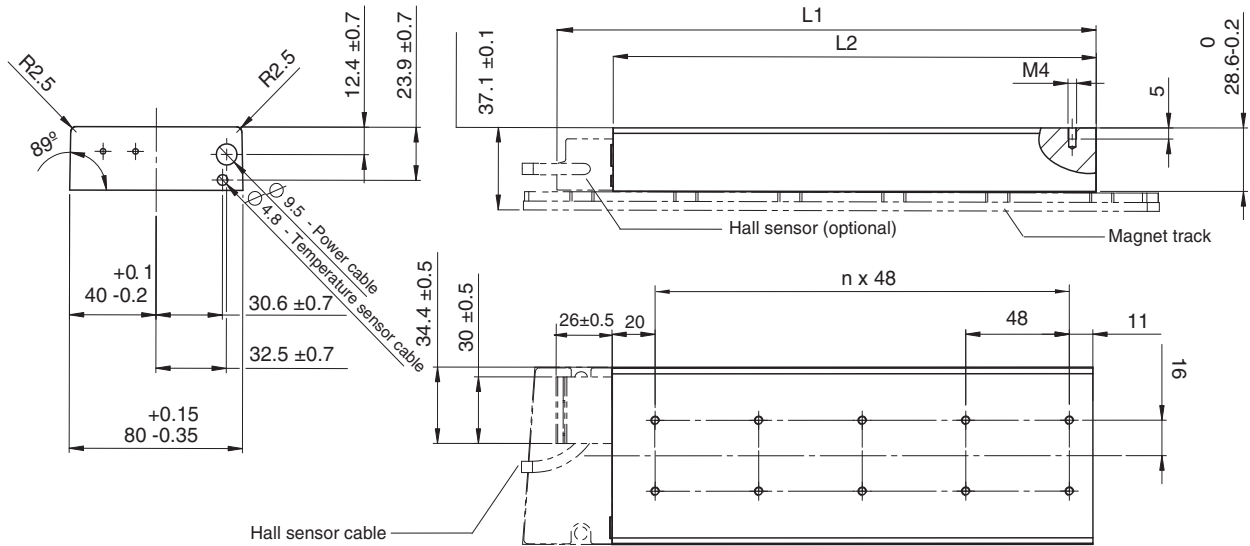

Wiring specifications for motor with connectors

Units: mm



Cable length 500±30
Connector optional
Made by Hypertac
LRR06AMRPN182 (MALE)
Pin article code: 021.279.1020

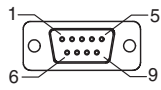

Cable length 500±30
Connector optional
D-Sub 9-pin (MALE)

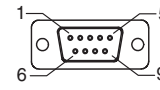

Cable length 500±30
D-Sub 9-pin (MALE)

Power connector		
Pin No.	Wire	Function
1	Black-1	Phase U
2	Black-2	Phase V
3	Green/Yellow	Ground
4	Black-3	Phase W
5	Not used	-
6	Not used	-

Mating connector:
Plug type: LPRA06BFRBN170

Temperature sensor connector		
Pin No.	Wire	Function
1	Not used	-
2	Not used	-
3	Not used	-
4	Not used	-
5	Not used	-
6	White	PTC
7	Brown	PTC
8	Green	KTY
9	Yellow	KTY
Case	Shield	-

Hall sensor connector (optional)		
Pin No.	Wire	Function
1	Brown	5V
2	Grey	Hall U
3	Red	Hall V
4	Yellow	Hall W
5	White	GND
6	Not used	Not used
7	Not used	Not used
8	Not used	Not used
9	Not used	Not used
Case	Shield	-

Magnet track

Model	L1 (mm)	n	Approx. weight (Kg/m)
R88L-EC-FM-06192-A	192	3	3.8
R88L-EC-FM-06288-A	288	5	

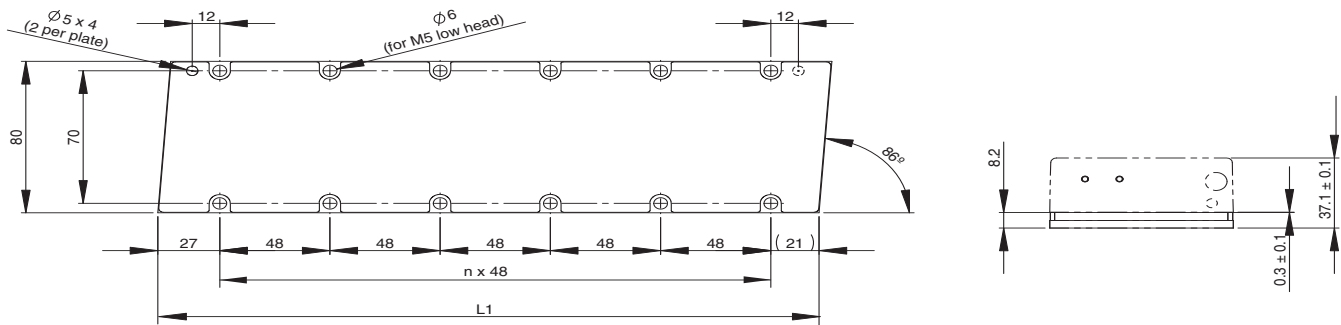

Iron-core R88L-EC-FW-11□

Motor coil

Model	L1 (mm)	L2 (mm)	n
R88L-EC-FW-1112-□	249 +/-0.5	223 +0.15/-0.35	4
R88L-EC-FW-1115-□	297 +/-0.5	271 +0.15/-0.35	5

Motor coil dimensions with magnet track and hall sensor (optional)

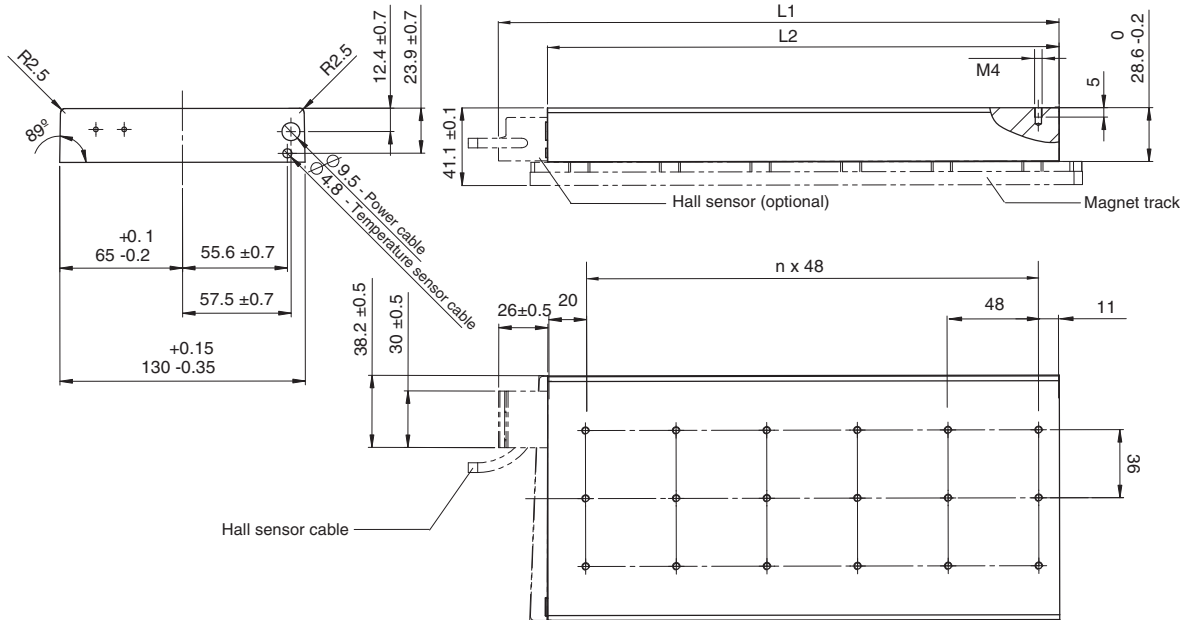

Wiring specifications for motor with connectors

Units: mm



Cable length 500±30
Connector optional
Made by Hypertac
LPRRA06AMRPN182 (MALE)
Pin article code: 021.279.1020

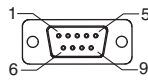

Cable length 500±30
Connector optional
D-Sub 9-pin (MALE)

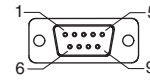

Cable length 500±30
D-Sub 9-pin (MALE)

Power connector		
Pin No.	Wire	Function
1	Black-1	Phase U
2	Black-2	Phase V
3	Green/Yellow	Ground
4	Black-3	Phase W
5	Not used	-
6	Not used	-

Mating connector:
Plug type: LPRRA06BFRBN170

Temperature sensor connector		
Pin No.	Wire	Function
1	Not used	-
2	Not used	-
3	Not used	-
4	Not used	-
5	Not used	-
6	White	PTC
7	Brown	PTC
8	Green	KTY
9	Yellow	KTY
Case	Shield	-

Hall sensor connector (optional)		
Pin No.	Wire	Function
1	Brown	5V
2	Grey	Hall U
3	Red	Hall V
4	Yellow	Hall W
5	White	GND
6	Not used	Not used
7	Not used	Not used
8	Not used	Not used
9	Not used	Not used
Case	Shield	-

Magnet track

Model	L1 (mm)	n	Approx. weight (Kg/m)
R88L-EC-FM-11192-A	192	3	10.5
R88L-EC-FM-11288-A	288	5	

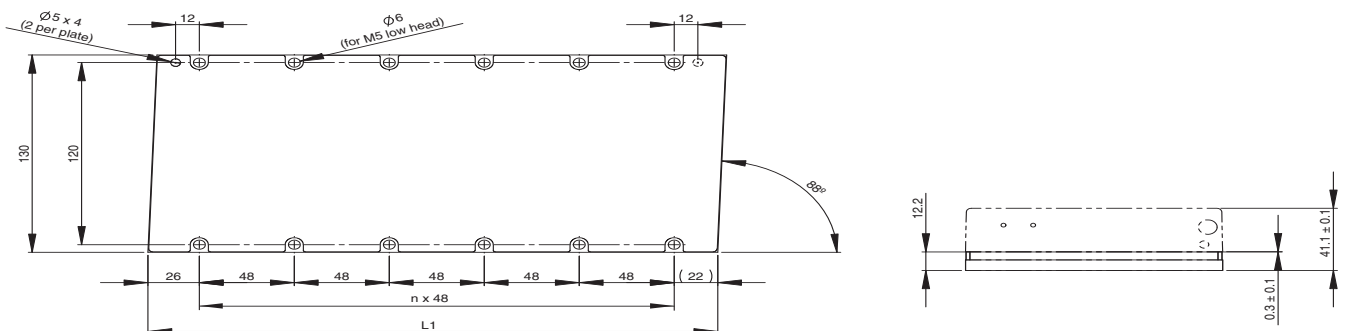

Ironless R88L-EC-GW-03

Motor coil

Model	L1 (mm)	L2 (mm)	n
R88L-EC-GW-0303-	95.4	78	3
R88L-EC-GW-0306-	155.4	138	6
R88L-EC-GW-0309-	215.4	198	9

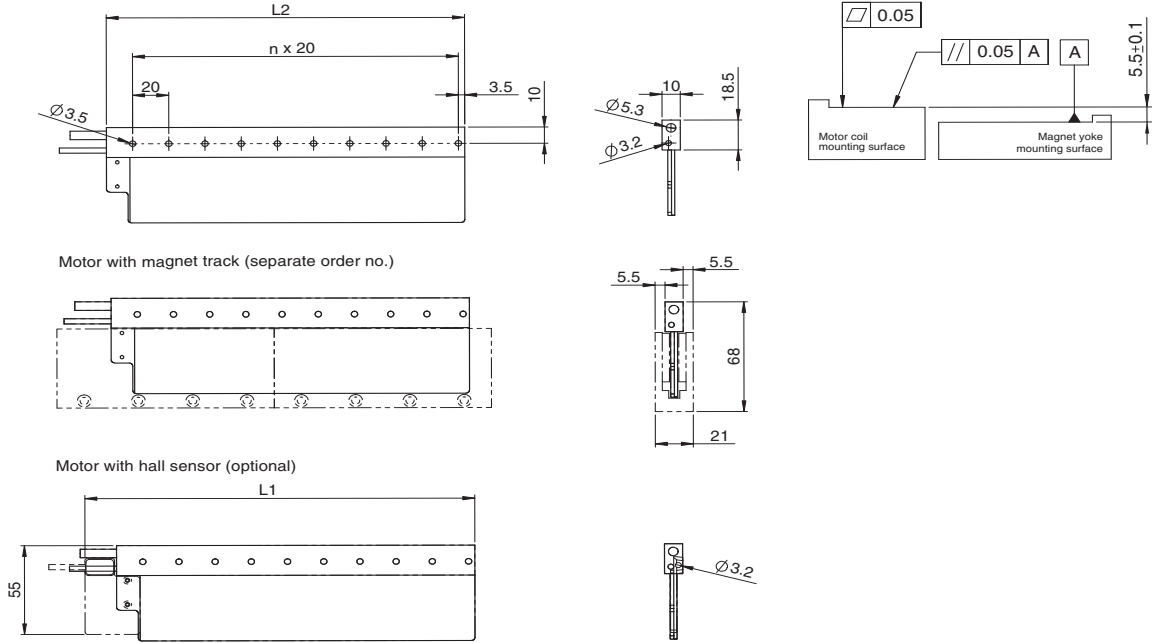

Motor with magnet track (separate order no.)

Motor with hall sensor (optional)

Wiring specifications for motor with connectors

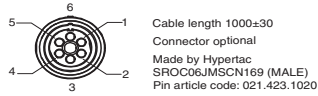

Power connector		
Pin No.	Wire	Function
1	Black-1	Phase U
2	Black-2	Phase V
3	Black-3	Phase W
4	Not used	-
5	Not used	-
6	Green/Yellow	Ground

Mating connector:
Plug type: SPOC06KFSDN169

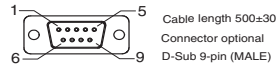

Temperature sensor connector		
Pin No.	Wire	Function
1	Not used	-
2	Not used	-
3	Not used	-
4	Not used	-
5	Not used	-
6	White	PTC
7	Brown	PTC
8	Green	NTC
9	Yellow	NTC
Case	Shield	-

Units: mm

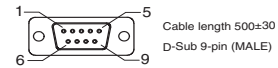

Hall sensor connector (optional)		
Pin No.	Wire	Function
1	Brown	5V
2	Grey	Hall U
3	Red	Hall V
4	Yellow	Hall W
5	White	GND
6	Not used	Not used
7	Not used	Not used
8	Not used	Not used
9	Not used	Not used
Case	Shield	-

Magnet track

Model	L1 (mm)	n	Approx. weight (Kg/m)
R88L-EC-GM-03090-A	90	2	4.8
R88L-EC-GM-03120-A	120	3	
R88L-EC-GM-03390-A	390	12	

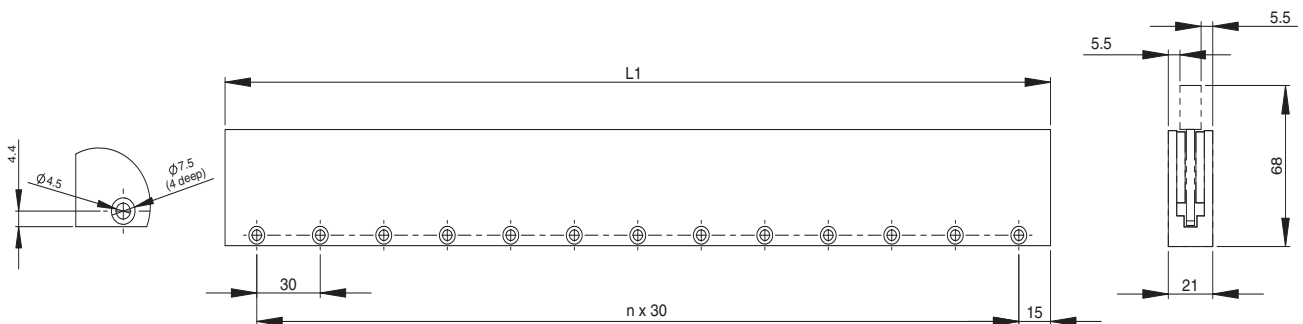

Ironless R88L-EC-GW-05□

Motor coil

Model	L1 (mm)	L2 (mm)	n
R88L-EC-GW-0503-□	123.4	106	3
R88L-EC-GW-0506-□	207.4	190	6
R88L-EC-GW-0509-□	291.4	274	9

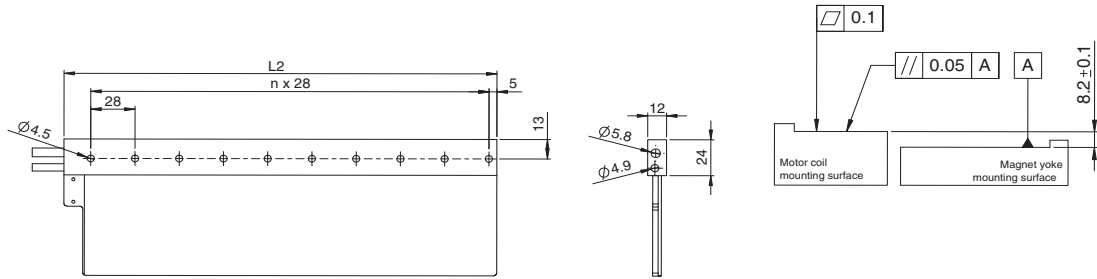

Motor with magnet track (separate order no.)

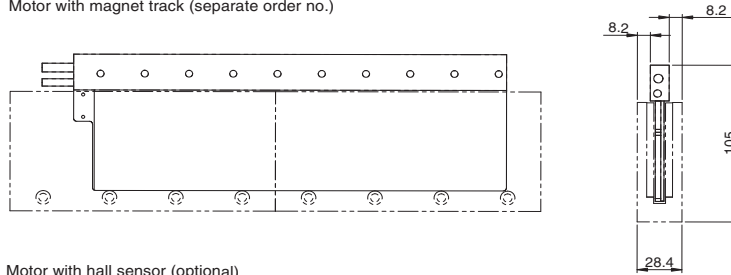

Motor with hall sensor (optional)

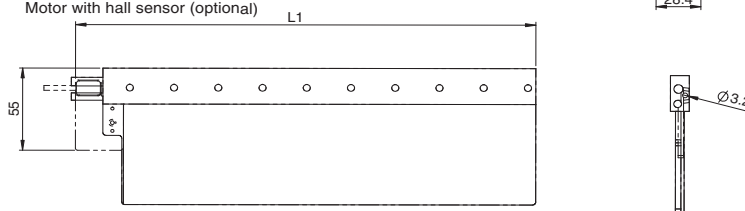

Wiring specifications for motor with connectors

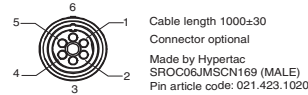

Power connector		
Pin No.	Wire	Function
1	Black-1	Phase U
2	Black-2	Phase V
3	Black-3	Phase W
4	Not used	-
5	Not used	-
6	Green/Yellow	Ground

Mating connector:
Plug type: SPOC06KFSN169

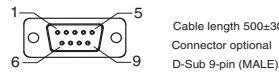

Temperature sensor connector		
Pin No.	Wire	Function
1	Not used	-
2	Not used	-
3	Not used	-
4	Not used	-
5	Not used	-
6	White	PTC
7	Brown	PTC
8	Green	NTC
9	Yellow	NTC
Case	Shield	-

Units: mm



Hall sensor connector (optional)		
Pin No.	Wire	Function
1	Brown	5V
2	Grey	Hall U
3	Red	Hall V
4	Yellow	Hall W
5	White	GND
6	Not used	Not used
7	Not used	Not used
8	Not used	Not used
9	Not used	Not used
Case	Shield	-

Magnet track

Model	L1 (mm)	n	Approx. weight (Kg/m)
R88L-EC-GM-05126-A	126	2	11.2
R88L-EC-GM-05168-A	168	3	
R88L-EC-GM-05210-A	210	4	
R88L-EC-GM-05546-A	546	12	

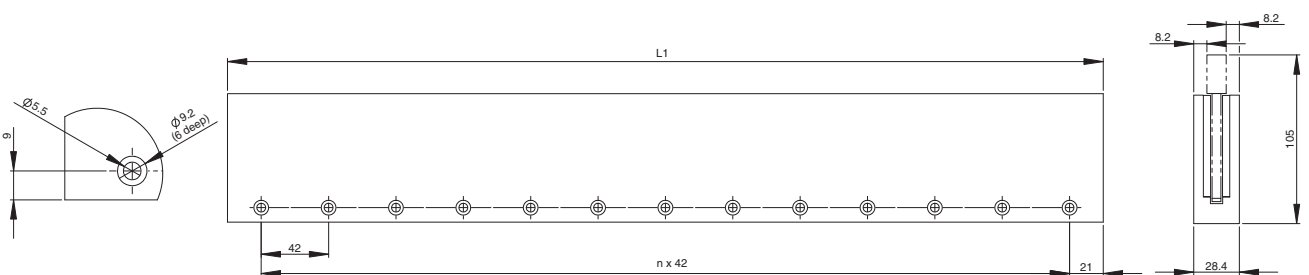

Ironless R88L-EC-GW-07□

Motor coil

Model	L1 (mm)	L2 (mm)	n
R88L-EC-GW-0703-□	151.4	134	3
R88L-EC-GW-0706-□	265.4	248	6
R88L-EC-GW-0709-□	379.4	362	9

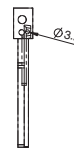
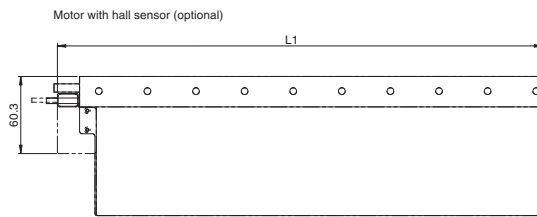
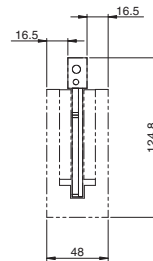
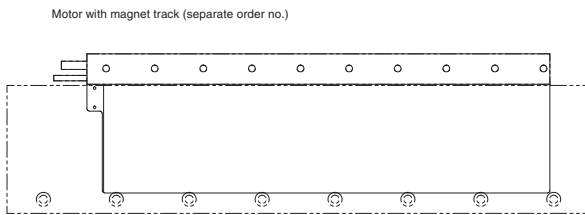
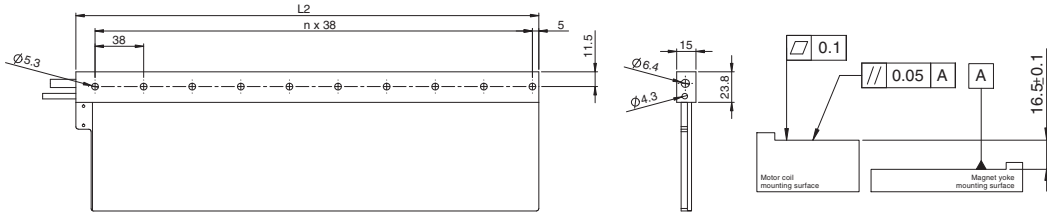

Wiring specifications for motor with connectors

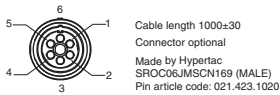

Pin No.	Wire	Function
1	Black-1	Phase U
2	Black-2	Phase V
3	Black-3	Phase W
4	Not used	-
5	Not used	-
6	Green/Yellow	Ground

Mating connector:
Plug type: SPOC06KFSN169

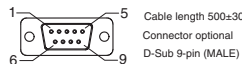

Pin No.	Wire	Function
1	Not used	-
2	Not used	-
3	Not used	-
4	Not used	-
5	Not used	-
6	White	PTC
7	Brown	PTC
8	Green	NTC
9	Yellow	NTC
Case	Shield	-

Units: mm



Pin No.	Wire	Function
1	Brown	5V
2	Grey	Hall U
3	Red	Hall V
4	Yellow	Hall W
5	White	GND
6	Not used	Not used
7	Not used	Not used
8	Not used	Not used
9	Not used	Not used
Case	Shield	-

Magnet track

Model	L1 (mm)	n	Approx. weight (Kg/m)
R88L-EC-GM-07114-A	114	1	25.5
R88L-EC-GM-07171-A	171	2	
R88L-EC-GM-07456-A	456	7	

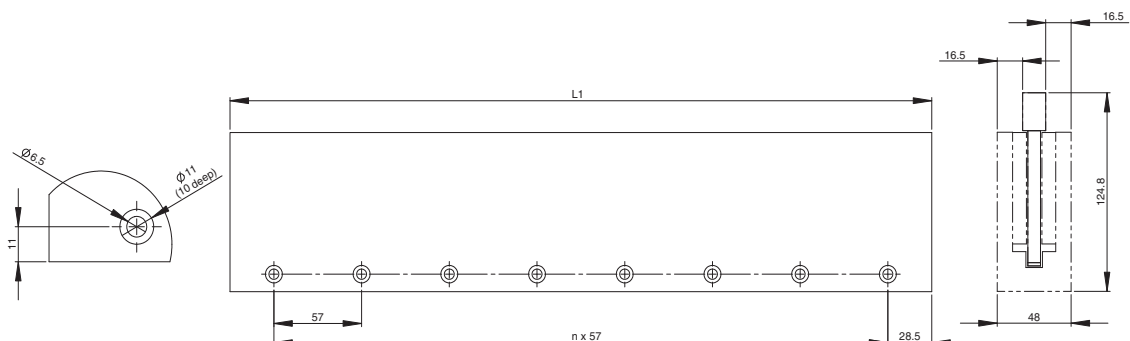

Optional serial Converter unit

Specifications

Serial converter model R88A-		SC01K-E	SC02K-E
Description		Serial converter from 1 Vpp to G5 serial data transmission and with hall sensor input	
Temperature sensor		KTY sensor detection of iron-core motor coil	NTC sensor detection of ironless motor coil
Electrical characteristics	Power supply voltage	5 VDC, max. 250 mA supplied by the drive	
	Standard resolution	Interpolation factor 100 plus quadrature count	
	Max. input frequency	400 kHz 1 Vpp	
	Analog input signals (cos, sin, Ref)	Differential input amplitude: 0.4 V to 1.2 V Input signal level: 1.5 V to 3.5 V	
	Output signals	Position data, hall & temperature sensor information, and alarms	
	Output method	Serial data transmission	
	Transmission cycle	< 42 μs	
Mechanical characteristics	Vibration resistance	98 m/s ² max. (1 to 2500 Hz) in three directions	
	Shock resistance	980 m/s ² , (11 ms) two times in three directions	
Environmental conditions	Operating temperature	0 °C to 55 °C	
	Storage temperature	-20 °C to +80 °C	
	Humidity	20% to 90% relative humidity (without condensation)	

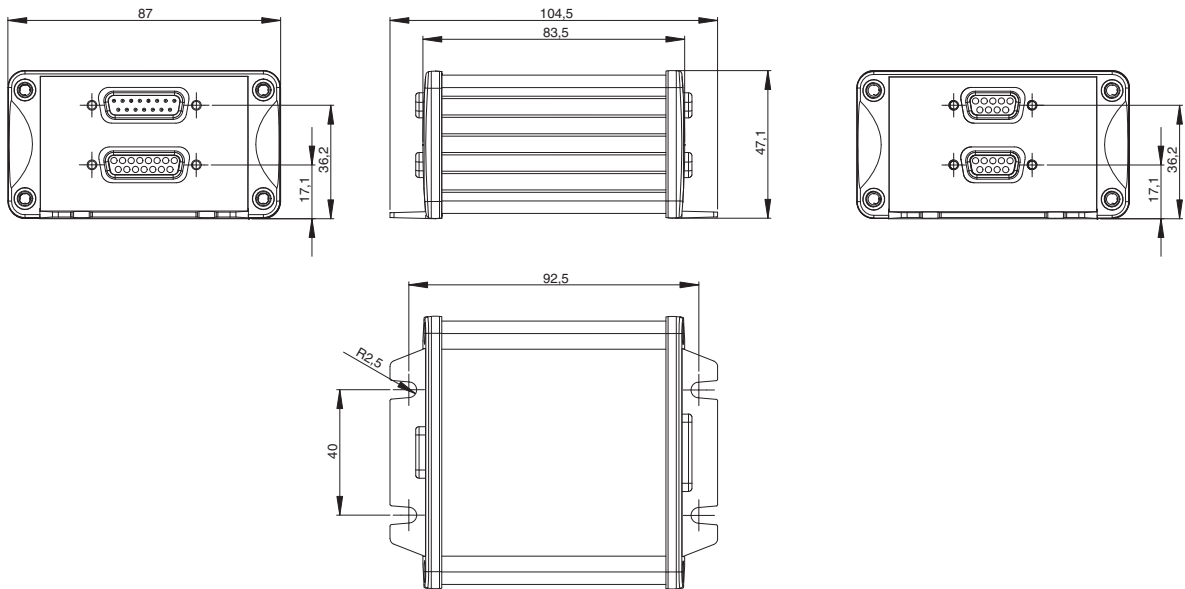

CN4
Serial data output to Linear Servo drive

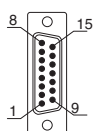

Connector D-Sub 15-pin (male)

Pin No.	Signal
1	PS
2	/PS
3	Not used
4	Not used
5	Not used
6	Not used
7	Not used
8	5V
9	0V
10	Not used
11	Not used
12	Not used
13	Not used
14	Not used
15	Inner shield
Case	Shield

CN3
Temperature sensor interface without Hall sensor



Connector D-Sub 9-pin (female)

Pin No.	Signal
1	Not used
2	Not used
3	Not used
4	Not used
5	Not used
6	PTC
7	PTC
8	KTY/ NTC
9	KTY/NTC
Case	Shield

CN1
Encoder input 1Vpp with programmable lines NUMERIK JENA standard

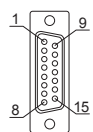

Connector D-Sub 15-pin (female)

Pin No.	Signal
1	SDA*
2	SCL*
3	Not used
4	/Ref signal (U ₀ -)
5	/Cos signal (U ₂ -)
6	/Sin signal (U ₁ -)
7	Not used
8	5V
9	0V
10	Not used
11	Not used
12	Ref signal (U ₀)
13	Cos signal (U ₂)
14	Sin signal (U ₁)
15	Inner shield (IS)
Case	Shield

CN2
Hall & temperature sensors interface



Connector D-Sub 9-pin (female)

Pin No.	Signal
1	5V
2	Hall U
3	Hall V
4	Hall W
5	GND
6	PTC
7	PTC
8	KTY/NTC
9	KTY/NTC
Case	Shield

*Reserved. Please do not use

Note: As the 6,7,8,9 pins in the CN2 and CN3 connectors are internally wired, the Temperature sensor can be connected to both connectors. When the Hall sensor is also required, use the same cable for Hall & Temperature signals and the CN2 connector.

Ordering information

(Refer to servo drive chapter)

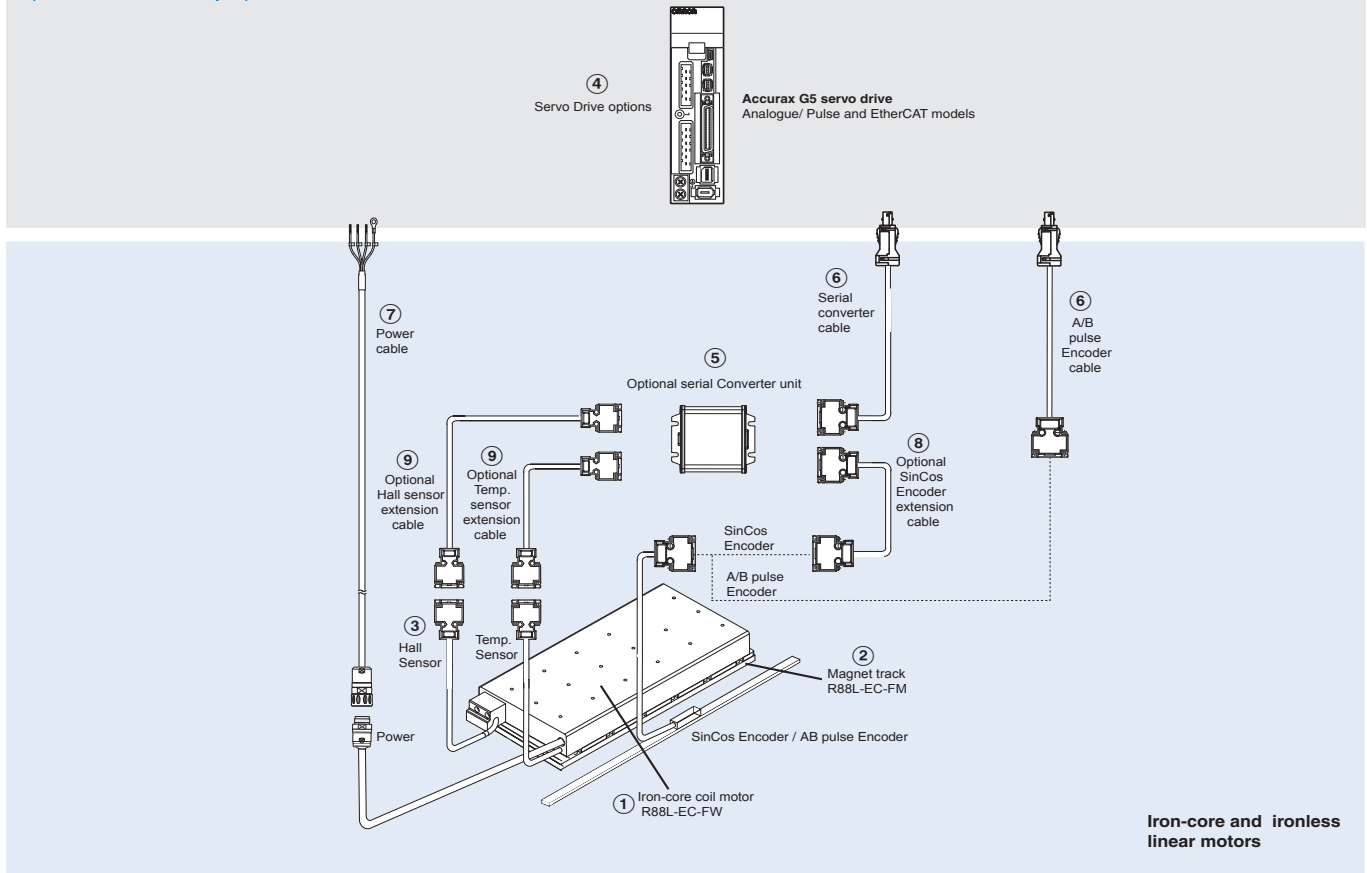

Note: The symbols ①②③... show the recommended sequence to select the linear motor, cables and serial converter for a linear motor system.

Linear motors

R88L-EC-FW-□ Iron-core type

230VAC single phase/three phase, 400VAC three phase

Linear motor parts						Linear Servo drive		
Symbol	Rated force	Peak force	① Iron-core motor coil	② Magnet track	③ Hall Sensor	④ Accurax G5 EtherCAT & Analog/pulse		
						230V	400V	
	48 N	105 N	Coil without connectors	R88L-EC-FW-0303-ANPC	R88L-EC-FM-03096-A	R88L-EC-FH-NNIN-A	R88D-K□02H-□□□□-L	R88D-K□06F□□□□-L
	96 N	210 N		R88L-EC-FW-0306-ANPC	R88L-EC-FM-03144-A R88L-EC-FM-03384-A		R88D-K□04H-□□□□-L	R88D-K□10F□□□□-L
	160 N	400 N		R88L-EC-FW-0606-ANPC	R88L-EC-FM-06192-A		R88D-K□08H-□□□□-L	R88D-K□15F□□□□-L
	240 N	600 N		R88L-EC-FW-0609-ANPC	R88L-EC-FM-06288-A		R88D-K□10H-□□□□-L	R88D-K□20F□□□□-L
	320 N	800 N		R88L-EC-FW-0612-ANPC	R88L-EC-FM-11192-A		R88D-K□15H-□□□□-L	R88D-K□30F□□□□-L
	608 N	1600 N		R88L-EC-FW-1112-ANPC	R88L-EC-FM-11288-A		R88D-K□15H-□□□□-L	R88D-K□30F□□□□-L
	760 N	2000 N		R88L-EC-FW-1115-ANPC	R88L-EC-FM-11288-A		R88D-K□15H-□□□□-L	R88D-K□30F□□□□-L
	48 N	105 N	Coil with connectors	R88L-EC-FW-0303-APLC	R88L-EC-FM-03096-A		R88D-K□02H-□□□□-L	R88D-K□06F□□□□-L
	96 N	210 N		R88L-EC-FW-0306-APLC	R88L-EC-FM-03144-A R88L-EC-FM-03384-A		R88D-K□04H-□□□□-L	R88D-K□10F□□□□-L
	160 N	400 N		R88L-EC-FW-0606-APLC	R88L-EC-FM-06192-A		R88D-K□08H-□□□□-L	R88D-K□15F□□□□-L
	240 N	600 N		R88L-EC-FW-0609-APLC	R88L-EC-FM-06288-A		R88D-K□10H-□□□□-L	R88D-K□20F□□□□-L
	320 N	800 N		R88L-EC-FW-0612-APLC	R88L-EC-FM-11192-A		R88D-K□15H-□□□□-L	R88D-K□30F□□□□-L
	608 N	1600 N		R88L-EC-FW-1112-APLC	R88L-EC-FM-11288-A		R88D-K□15H-□□□□-L	R88D-K□30F□□□□-L
	760 N	2000 N		R88L-EC-FW-1115-APLC	R88L-EC-FM-11288-A		R88D-K□15H-□□□□-L	R88D-K□30F□□□□-L

R88L-EC-GW-□ Ironless type

200VAC single phase/ three phase

Linear motor parts						Linear Servo drive					
Type	Rated force	Peak force	① Ironless motor coil			④ Accurax G5					
			② Magnet track	③ Hall Sensor	230V (EtherCAT)	230V (Analog/pulse)					
	Coil without connectors	26,5N	100 N	R88L-EC-GW-0303-ANPS	R88L-EC-GM-03090-A	R88L-EC-GH-03NN-A	R88D-KN02H-ECT-L	R88D-KT02H-L			
		53 N	200 N	R88L-EC-GW-0306-ANPS	R88L-EC-GM-03120-A		R88D-KN08H-ECT-L	R88D-KT08H-L			
		80 N	300 N	R88L-EC-GW-0309-ANPS	R88L-EC-GM-03390-A		R88D-KN10H-ECT-L	R88D-KT10H-L			
		58 N	240 N	R88L-EC-GW-0503-ANPS	R88L-EC-GM-05126-A		R88L-EC-GH-05NN-A	R88D-KN02H-ECT-L	R88D-KT02H-L		
		117 N	480 N	R88L-EC-GW-0506-ANPS	R88L-EC-GM-05546-A			R88D-KN04H-ECT-L	R88D-KT04H-L		
		175 N	720 N	R88L-EC-GW-0509-ANPS	R88L-EC-GM-05168-A			R88D-KN08H-ECT-L	R88D-KT08H-L		
		117 N	700 N	R88L-EC-GW-0703-ANPS	R88L-EC-GM-07114-A			R88L-EC-GH-07NN-A	R88D-KN04H-ECT-L	R88D-KT04H-L	
		232 N	1400 N	R88L-EC-GW-0706-ANPS	R88L-EC-GM-07171-A				R88D-KN08H-ECT-L	R88D-KT08H-L	
		348 N	2100 N	R88L-EC-GW-0709-ANPS	R88L-EC-GM-07456-A				R88D-KN10H-ECT-L	R88D-KT10H-L	
		26,5N	100 N	R88L-EC-GW-0303-APLS	R88L-EC-GM-03090-A				R88L-EC-GH-03NN-A	R88D-KN02H-ECT-L	R88D-KT02H-L
		53 N	200 N	R88L-EC-GW-0306-APLS	R88L-EC-GM-03120-A					R88D-KN08H-ECT-L	R88D-KT08H-L
		80 N	300 N	R88L-EC-GW-0309-APLS	R88L-EC-GM-03390-A					R88D-KN10H-ECT-L	R88D-KT10H-L
	58 N	240 N	R88L-EC-GW-0503-APLS	R88L-EC-GM-05126-A	R88L-EC-GH-05NN-A	R88D-KN02H-ECT-L		R88D-KT02H-L			
	117 N	480 N	R88L-EC-GW-0506-APLS	R88L-EC-GM-05546-A		R88D-KN04H-ECT-L		R88D-KT04H-L			
	175 N	720 N	R88L-EC-GW-0509-APLS	R88L-EC-GM-05210-A		R88D-KN08H-ECT-L		R88D-KT08H-L			
	117 N	700 N	R88L-EC-GW-0703-APLS	R88L-EC-GM-07114-A		R88L-EC-GH-07NN-A	R88D-KN04H-ECT-L	R88D-KT04H-L			
	232 N	1400 N	R88L-EC-GW-0706-APLS	R88L-EC-GM-07171-A			R88D-KN08H-ECT-L	R88D-KT08H-L			
	348 N	2100 N	R88L-EC-GW-0709-APLS	R88L-EC-GM-07456-A			R88D-KN10H-ECT-L	R88D-KT10H-L			

Servo Drive

④ Refer to Accurax G5 Servo Drive chapter for detailed drive specifications and selection of drive accessories.

Serial Converter unit

Symbol	Specifications	Model
⑤	Serial converter unit from 1 Vpp to G5 serial data transmission (with KTY sensor detection of iron-core motor coil)	R88A-SC01K-E
	Serial converter unit from 1 Vpp to G5 serial data transmission (with NTC sensor detection of ironless motor coil)	R88A-SC02K-E

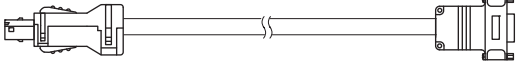

Note: If no temperature sensor is needed, then it does not matter which converter you use.

Serial Converter cable to Servo Drive

Symbol	Specifications	Model	Appearance	
⑥	Accurax G5-Linear drive to Serial Converter cable. (Connectors R88A-CNK41L and DB-15)	1.5 m	R88A-CRKN001-5CR-E	
		3 m	R88A-CRKN003CR-E	
		5 m	R88A-CRKN005CR-E	
		10 m	R88A-CRKN010CR-E	
		15 m	R88A-CRKN015CR-E	
		20 m	R88A-CRKN020CR-E	

Note: This cable can be used also for A/B Pulse Encoder Numerik Jena standard pinout.

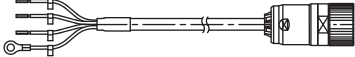
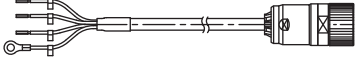
Power cable

Symbol	Specifications	Model	Appearance	
⑦	For iron-core linear motors R88L-EC-FW-0303-□ R88L-EC-FW-0306-□	1.5 m	R88A-CAWK001-5S-DE	
		3 m	R88A-CAWK003S-DE	
		5 m	R88A-CAWK005S-DE	
		10 m	R88A-CAWK010S-DE	
		15 m	R88A-CAWK015S-DE	
		20 m	R88A-CAWK020S-DE	
	For iron-core linear motors R88L-EC-FW-0606-□ R88L-EC-FW-0609-□ R88L-EC-FW-0612-□ R88L-EC-FW-1112-□ R88L-EC-FW-1115-□	1.5 m	R88A-CAWL001-5S-DE	
		3 m	R88A-CAWL003S-DE	
		5 m	R88A-CAWL005S-DE	
		10 m	R88A-CAWL010S-DE	
		15 m	R88A-CAWL015S-DE	
		20 m	R88A-CAWL020S-DE	
	For ironless linear motors R88L-EC-GW-□	1.5 m	R88A-CAWB001-5S-DE	
		3 m	R88A-CAWB003S-DE	
		5 m	R88A-CAWB005S-DE	
		10 m	R88A-CAWB010S-DE	
		15 m	R88A-CAWB015S-DE	
		20 m	R88A-CAWB020S-DE	

Linear Encoder cable to Serial Converter

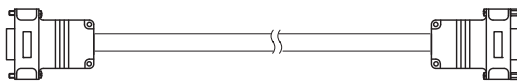
Symbol	Specifications	Model	Appearance	
⑧	Extension cable for Numerik Jena Linear Encoder to R88A-SC0□K-E serial converter (Connector DB-15) (This extension cable is optional)	1.5 m	R88A-CFKA001-5CR-E	
		3 m	R88A-CFKA003CR-E	
		5 m	R88A-CFKA005CR-E	
		10 m	R88A-CFKA010CR-E	
		15 m	R88A-CFKA015CR-E	
	Extension cable for Renishaw Linear Encoder to R88A-SC0□K-E serial converter (Connector DB-15) (This extension cable is optional)	1.5 m	R88A-CFKC001-5CR-E	
		3 m	R88A-CFKC003CR-E	
		5 m	R88A-CFKC005CR-E	
		10 m	R88A-CFKC010CR-E	
		15 m	R88A-CFKC015CR-E	
	Extension cable for Heidenhain Linear Encoder to R88A-SC0□K-E serial converter (Connector DB-15) (This extension cable is optional)	1.5 m	R88A-CFKD001-5CR-E	
		3 m	R88A-CFKD003CR-E	
		5 m	R88A-CFKD005CR-E	
		10 m	R88A-CFKD010CR-E	
		15 m	R88A-CFKD015CR-E	

Hall and Temperature sensors cable to Serial Converter

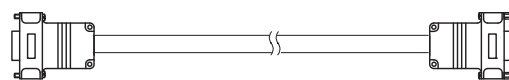
Symbol	Specifications	Model	Appearance	
⑨	Extension cable from Hall and Temperature sensors to R88A-SC0□K-E serial converter. (Connector DB-9) (This extension cable is optional)	1.5 m	R88A-CFKB001-5CR-E	
		3 m	R88A-CFKB003CR-E	
		5 m	R88A-CFKB005CR-E	
		10 m	R88A-CFKB010CR-E	
		15 m	R88A-CFKB015CR-E	

Connectors

Specification	Model
Accurax G5 servo drive encoder connector (for CN4)	R88A-CNK41L
Hypertac power cable connector IP67 for iron-core linear motors	LPRA-06B-FRBN170
Hypertac power cable connector IP67 for ironless linear motors	SPOC06KFSDN169

ALL DIMENSIONS SHOWN ARE IN MILLIMETERS.
To convert millimeters into inches, multiply by 0.03937. To convert grams into ounces, multiply by 0.03527.

R88L-EA-AF-□

Accurax linear motor axis

Advanced linear motor axis

High-efficiency iron-core linear motors and magnet tracks in a wide range of over 100 standard linear motor axes.

- Low moving mass to ensure a high degree of dynamism
- Optimized stroke/ product length ratio
- Up to 5 m/s maximum speed with 1 μm repeatability
- Compact and efficiency oriented design
- Highly versatile and ready-to-use

Ratings

- 230/ 400 VAC 48 to 760 N (2000 N peak force)



AC Servo systems

System configuration

(Refer to Servo Drive section)

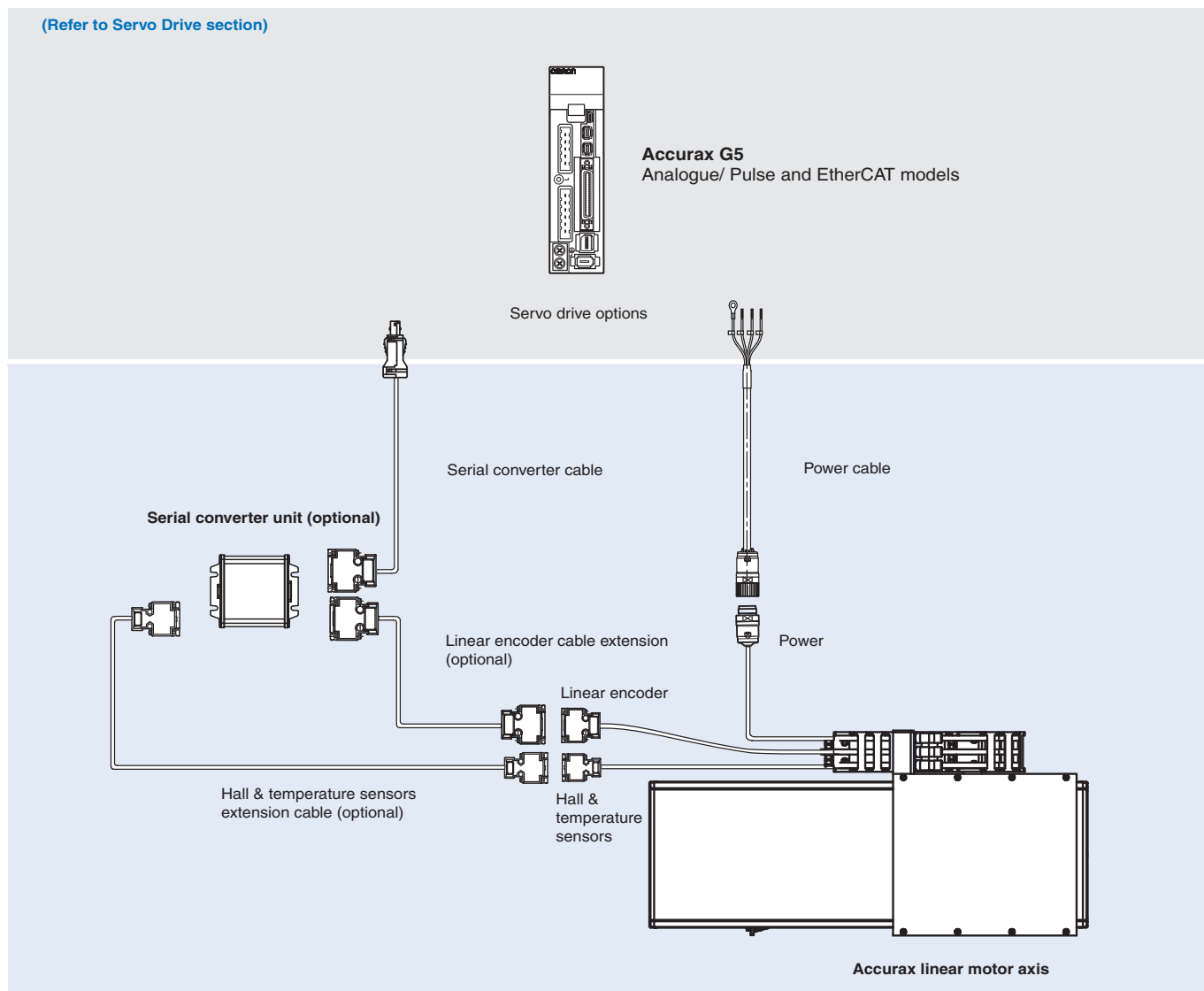

Linear axis					Servo drive			
Type	Voltage	Rated force	Peak force	Model	Accurax G5 EtherCAT		Accurax G5 analog/pulse	
					230 V	400 V	230 V	400 V
R88L-EA-AF-□ Linear motor axes 	230/ 400 V	48 N	105 N	R88L-EA-AF-0303-□	R88D-KN02H-ECT-L	R88D-KN10F-ECT-L	R88D-KT02H-L	R88D-KT10F-L
		96 N	210 N	R88L-EA-AF-0306-□	R88D-KN04H-ECT-L	R88D-KN10F-ECT-L	R88D-KT04H-L	R88D-KT10F-L
		160 N	400 N	R88L-EA-AF-0606-□	R88D-KN08H-ECT-L	R88D-KN15F-ECT-L	R88D-KT08H-L	R88D-KT15F-L
		240 N	600 N	R88L-EA-AF-0609-□	R88D-KN10H-ECT-L	R88D-KN20F-ECT-L	R88D-KT10H-L	R88D-KT20F-L
		320 N	800 N	R88L-EA-AF-0612-□	R88D-KN15H-ECT-L	R88D-KN30F-ECT-L	R88D-KT15H-L	R88D-KT30F-L
		608 N	1600 N	R88L-EA-AF-1112-□	R88D-KN15H-ECT-L	R88D-KN30F-ECT-L	R88D-KT15H-L	R88D-KT30F-L
		760 N	2000 N	R88L-EA-AF-1115-□	R88D-KN15H-ECT-L	R88D-KN30F-ECT-L	R88D-KT15H-L	R88D-KT30F-L

Type designation

Linear motor axis

R88L - EA - AF - 0303 - 0110 - □

Accurax linear motor axis

Customised versions

Iron-core linear motor model	
Code	Specifications
0303	30 mm active magnet width, 3 coil
0306	30 mm active magnet width, 6 coil
0606	60 mm active magnet width, 6 coil
0609	60 mm active magnet width, 9 coil
0612	60 mm active magnet width, 12 coil
1112	110 mm active magnet width, 12 coil
1115	110 mm active magnet width, 15 coil

Stroke length
(for effective stroke distances available see dimensions section)

Note: the standard linear motor axis includes 1 Vpp SinCos encoder. For another encoder options or customised versions of linear axis please contact your OMRON representative.

Servo motor specifications

Linear motor axis R88L-EA-AF-□ (230/ 400 VAC)

Voltage		230/ 400 VAC								
Linear axis model		R88L-EA-AF-□	0303-□	0306-□	0606-□	0609-□	0612-□	1112-□	1115-□	
Motor specifications	Linear servo motor coil used	R88L-EC-FW-	0303	0306	0606	0609	0612	1112	1115	
	Peak force* ¹	N	105	210	400	600	800	1600	2000	
	Peak current* ¹	Arms	3.1	6.1	10	15	20	20	25	
	Continuous force* ²	N	48	96	160	240	320	608	760	
	Continuous current* ²	Arms	1.2	2.5	3.4	5.2	6.9	6.5	8.2	
	Motor force constant	N / A _{rms}	39.7		46.5			93.0		
	BEMF	VDC/m/s	32		38			76		
	Motor constant	N / √w	9.75	13.78	19.49	23.87	27.57	41.47	46.37	
	Phase resistance	Ω	5.34	2.68	1.83	1.23	0.92	1.6	1.29	
	Phase Inductance	mH	34.7	17.4	13.7	9.2	6.9	12.8	10.3	
	Electrical time constant	ms	6.5		7.5			8		
Pole pitch	mm	24								
Mechanics	Weight of moving part	Kg	3.1	3.9	5.4	6.7	7.9	13.7	15.9	
	Recommended horizontal payload* ³	Kg	5		15			35		
	Uni-directional repeatability* ³	μm	±1							
	Max. allowable speed	m/s	5							
	Min. / max standard stroke	mm	110 / 2126	158 / 2078	110 / 2126	158 / 2078	110 / 2030	110 / 2126	158 / 2174	
Stroke increment	mm	96								
Feedback	Encoder type	1 Vptp SIN/COS & Reference mark, metalcase, optical, incremental								
	Encoder resolution	20μm								
	Accuracy class	±5μm/m								
	Hall sensor	Digital, TTL signals								
Other specifications	Protection methods* ⁴	Temperature sensors (KTY-83/ 121 & PTC 110C), self cooling								
	Hall-Sensor supply	5 to 24VDC, 25 mA								
	Encoder reading head supply	5 VDC, max. 250 mA								
	Insulation class	Class B								
	Max. bus voltage	560 VDC								
	Insulation resistance	500 VDC								
	Ambient humidity	20 to 80% (non-condensing)								
Altitude	1000 m									
Max. allowable magnet temperature	70°C									

*¹ Coil temperature rising by 6K/s.

*² Values at 100°C coil temperature and magnets at 25°C. An airstream of 2.5 m/s (25°C) has to be applied.

*³ Referring to the center of gravity, for higher payload or different position of payload please contact your OMRON representative.

*⁴ I²t has to be set properly for high current applications.

All other values at 25°C (+/-10%).

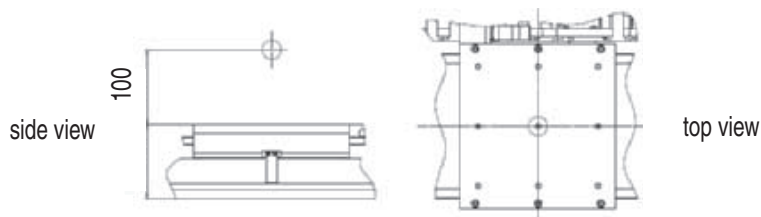

Acceleration-Payload characteristics

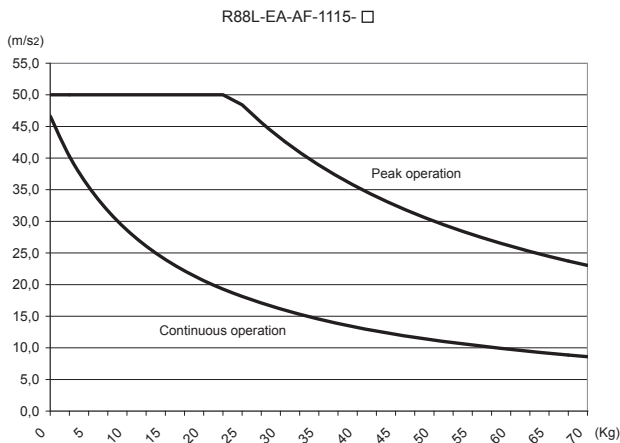
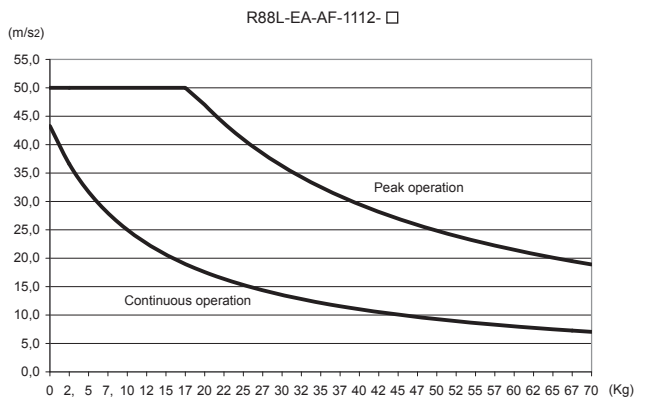
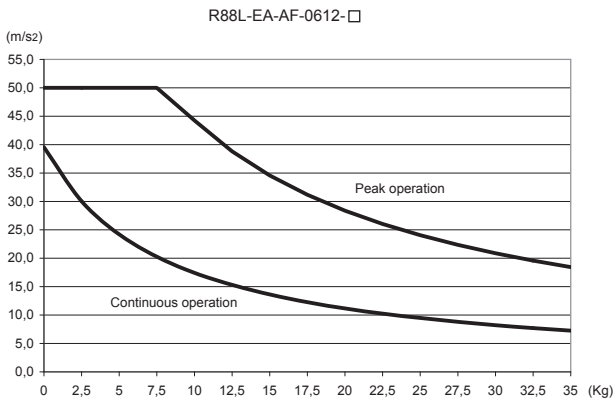
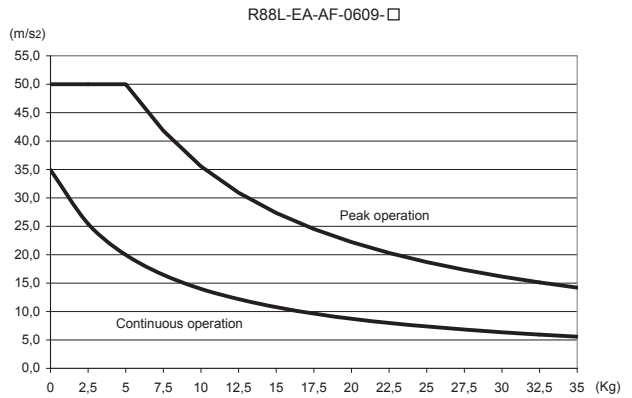
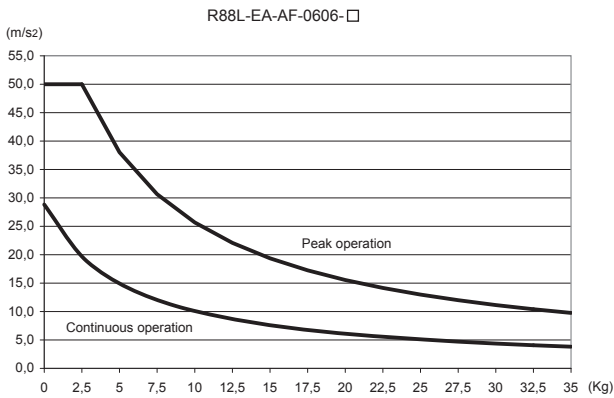
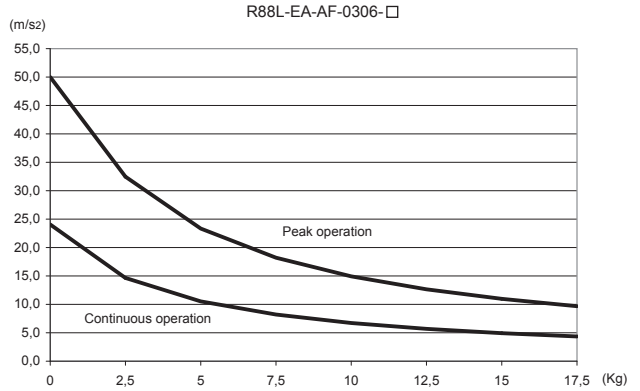
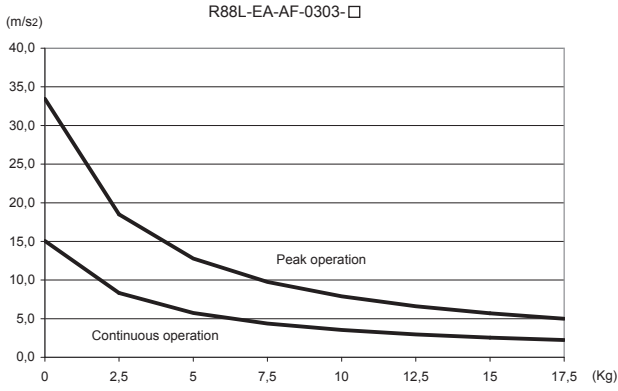

Note: The values on the above curves are calculated based on the below formula and with horizontal orientation:

$$Acceleration = (Force - Force_{Friction}) / Total\ moving\ mass$$

Dimensions

R88L-EA-AF-0303-□ (230/ 400 VAC)

Linear axis model	Effective stroke in mm	L in mm	n	N ^o of mounting holes	Weight of moving table including motor coil (kg)	Weight of the complete axis (kg)
R88L-EA-AF-0303-0110	110	312	2	6	3.1	9.5
R88L-EA-AF-0303-0206	206	408	3	8	3.1	10.9
R88L-EA-AF-0303-0302	302	504	4	10	3.1	12.4
R88L-EA-AF-0303-0398	398	600	5	12	3.1	13.8
R88L-EA-AF-0303-0494	494	696	6	14	3.1	15.2
R88L-EA-AF-0303-0590	590	792	7	16	3.1	16.7
R88L-EA-AF-0303-0686	686	888	8	18	3.1	18.1
R88L-EA-AF-0303-0782	782	984	9	20	3.1	19.6
R88L-EA-AF-0303-0878	878	1080	10	22	3.1	21.0
R88L-EA-AF-0303-0974	974	1176	11	24	3.1	22.5
R88L-EA-AF-0303-1070	1070	1272	12	26	3.1	23.9
R88L-EA-AF-0303-1166	1166	1368	13	28	3.1	25.4
R88L-EA-AF-0303-1262	1262	1464	14	30	3.1	26.8
R88L-EA-AF-0303-1358	1358	1560	15	32	3.1	28.2
R88L-EA-AF-0303-1454	1454	1656	16	34	3.1	29.7
R88L-EA-AF-0303-1550	1550	1752	17	36	3.1	31.1
R88L-EA-AF-0303-1646	1646	1848	18	38	3.1	32.6
R88L-EA-AF-0303-1742	1742	1944	19	40	3.1	34.0
R88L-EA-AF-0303-1838	1838	2040	20	42	3.1	35.5
R88L-EA-AF-0303-1934	1934	2136	21	44	3.1	36.9
R88L-EA-AF-0303-2030	2030	2232	22	46	3.1	38.3
R88L-EA-AF-0303-2126	2126	2328	23	48	3.1	39.8

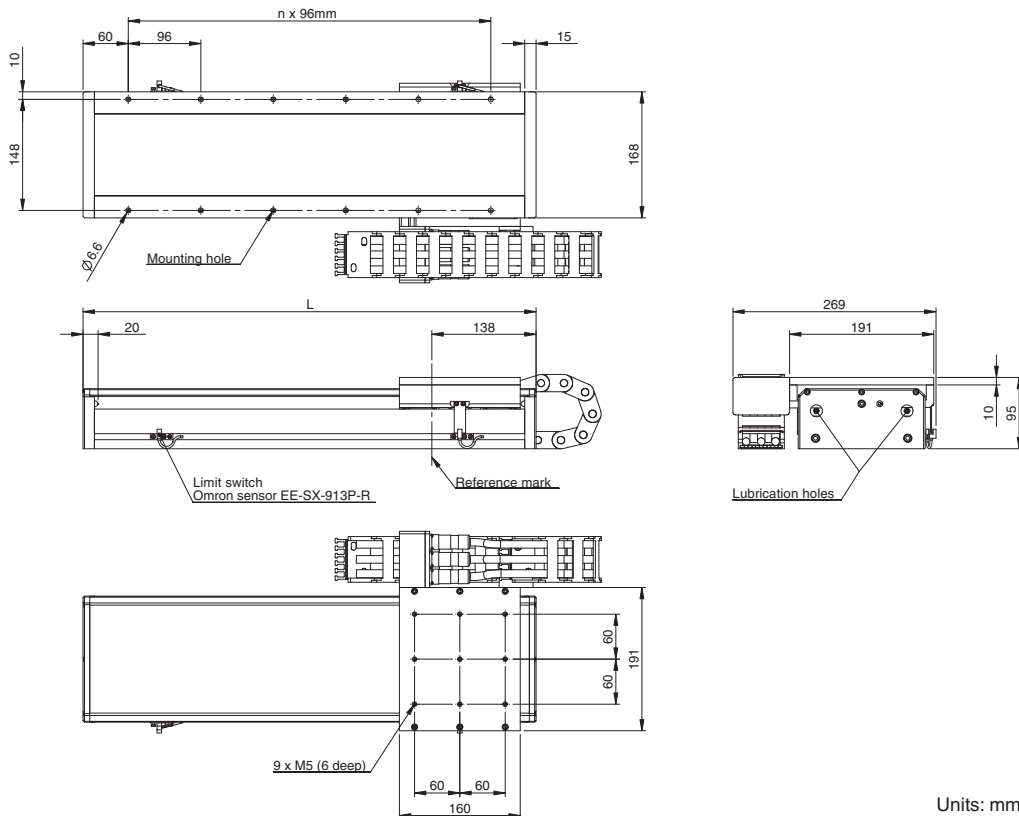

Units: mm

Hall sensor & temperature cable

Cable length 500 mm approx.
Connector D-Sub 9 pins (male)



Pin No.	Name
1	5V
2	Hall U
3	Hall V
4	Hall W
5	GND
6	PTC
7	PTC
8	KTY
9	KTY
Case	Shield

Encoder cable

Cable length 500 mm approx.
Connector D-Sub 15 pins (male)



Pin No.	Signal
1	SDA*
2	SCL*
3	Not used
4	/Ref signal (U ₀ -)
5	/Cos signal (U ₂ -)
6	/Sin signal (U ₁ -)
7	Not used
8	5V
9	0V
10	Not used
11	Not used
12	Ref signal (U ₀)
13	Cos signal (U ₂)
14	Sin signal (U ₁)
15	Inner shield (IS)
Case	Shield

*Reserved. Please do not use

Power cable

Cable length 500 mm approx.
Connector Hypertac
LRRA06AMRPN182 (male)
Pin article code: 021.279.1020



Pin No.	Name
1	Phase U
2	Phase V
3	Ground
4	Phase W
5	Not used
6	Not used

Mating connector:
Plug type: LPR06BFRBN170

R88L-EA-AF-0306-□ (230/ 400 VAC)

Linear axis model	Effective stroke in mm	L in mm	n	Nº of mounting holes	Weight of moving table including motor coil (kg)	Weight of the complete axis (kg)
R88L-EA-AF-0306-0158	158	408	3	8	3.9	11.6
R88L-EA-AF-0306-0254	254	504	4	10	3.9	13.1
R88L-EA-AF-0306-0350	350	600	5	12	3.9	14.5
R88L-EA-AF-0306-0446	446	696	6	14	3.9	15.9
R88L-EA-AF-0306-0542	542	792	7	16	3.9	17.4
R88L-EA-AF-0306-0638	638	888	8	18	3.9	18.8
R88L-EA-AF-0306-0734	734	984	9	20	3.9	20.3
R88L-EA-AF-0306-0830	830	1080	10	22	3.9	21.7
R88L-EA-AF-0306-0926	926	1176	11	24	3.9	23.2
R88L-EA-AF-0306-1022	1022	1272	12	26	3.9	24.6
R88L-EA-AF-0306-1118	1118	1368	13	28	3.9	26.1
R88L-EA-AF-0306-1214	1214	1464	14	30	3.9	27.5
R88L-EA-AF-0306-1310	1310	1560	15	32	3.9	28.9
R88L-EA-AF-0306-1406	1406	1656	16	34	3.9	30.4
R88L-EA-AF-0306-1502	1502	1752	17	36	3.9	31.8
R88L-EA-AF-0306-1598	1598	1848	18	38	3.9	33.3
R88L-EA-AF-0306-1694	1694	1944	19	40	3.9	34.7
R88L-EA-AF-0306-1790	1790	2040	20	42	3.9	36.2
R88L-EA-AF-0306-1886	1886	2136	21	44	3.9	37.6
R88L-EA-AF-0306-1982	1982	2232	22	46	3.9	39.0
R88L-EA-AF-0306-2078	2078	2328	23	48	3.9	40.5

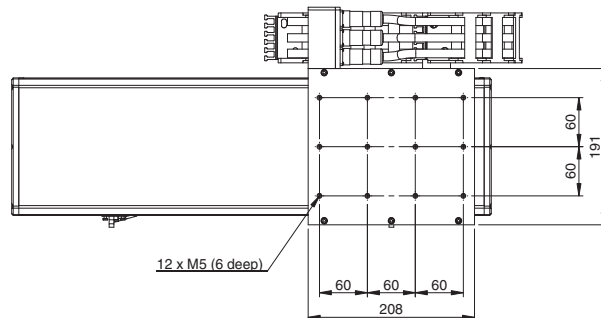
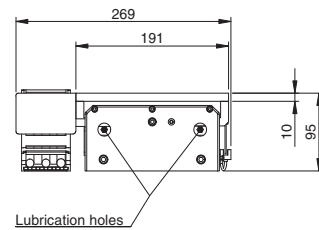
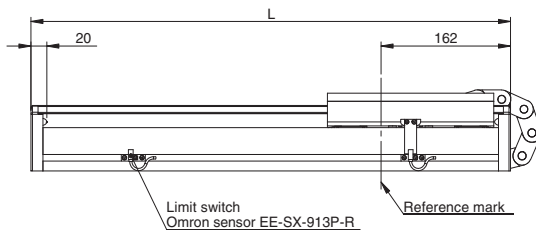
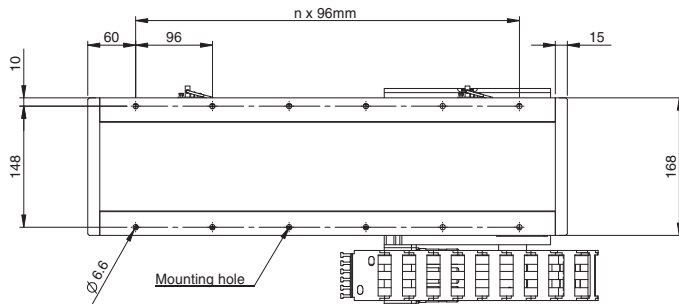

Units: mm

Hall sensor & temperature cable

Cable length 500 mm approx.
Connector D-Sub 9 pins (male)



Pin No.	Name
1	5V
2	Hall U
3	Hall V
4	Hall W
5	GND
6	PTC
7	PTC
8	KTY
9	KTY
Case	Shield

Encoder cable

Cable length 500 mm approx.
Connector D-Sub 15 pins (male)



Pin No.	Signal
1	SDA*
2	SCL*
3	Not used
4	/Ref signal (U ₂)
5	/Cos signal (U ₂ -)
6	/Sin signal (U ₁ -)
7	Not used
8	5 V
9	0 V
10	Not used
11	Not used
12	Ref signal (U ₀)
13	Cos signal (U ₂)
14	Sin signal (U ₁)
15	Inner shield (IS)
Case	Shield

*Reserved. Please do not use

Power cable

Cable length 500 mm approx.
Connector Hypertac
LRRA06AMRPN182 (male)
Pin article code: 021.279.1020



Pin No.	Name
1	Phase U
2	Phase V
3	Ground
4	Phase W
5	Not used
6	Not used

Mating connector:
Plug type: LPRA06BFRBN170

R88L-EA-AF-0606-□ (230/ 400 VAC)

Linear axis model	Effective stroke in mm	L in mm	n	N° of mounting holes	Weight of moving table including motor coil (kg)	Weight of the complete axis (kg)
R88L-EA-AF-0606-0110	110	360	3	8	5.4	14.1
R88L-EA-AF-0606-0206	206	456	4	10	5.4	15.9
R88L-EA-AF-0606-0302	302	552	5	12	5.4	17.6
R88L-EA-AF-0606-0398	398	648	6	14	5.4	19.3
R88L-EA-AF-0606-0494	494	744	7	16	5.4	21.0
R88L-EA-AF-0606-0590	590	840	8	18	5.4	22.8
R88L-EA-AF-0606-0686	686	936	9	20	5.4	24.5
R88L-EA-AF-0606-0782	782	1032	10	22	5.4	26.2
R88L-EA-AF-0606-0878	878	1128	11	24	5.4	28.0
R88L-EA-AF-0606-0974	974	1224	12	26	5.4	29.7
R88L-EA-AF-0606-1070	1070	1320	13	28	5.4	31.4
R88L-EA-AF-0606-1166	1166	1416	14	30	5.4	33.2
R88L-EA-AF-0606-1262	1262	1512	15	32	5.4	34.9
R88L-EA-AF-0606-1358	1358	1608	16	34	5.4	36.6
R88L-EA-AF-0606-1454	1454	1704	17	36	5.4	38.4
R88L-EA-AF-0606-1550	1550	1800	18	38	5.4	40.1
R88L-EA-AF-0606-1646	1646	1896	19	40	5.4	41.8
R88L-EA-AF-0606-1742	1742	1992	20	42	5.4	43.6
R88L-EA-AF-0606-1838	1838	2088	21	44	5.4	45.3
R88L-EA-AF-0606-1934	1934	2184	22	46	5.4	47.0
R88L-EA-AF-0606-2030	2030	2280	23	48	5.4	48.8
R88L-EA-AF-0606-2126	2126	2376	24	50	5.4	50.5

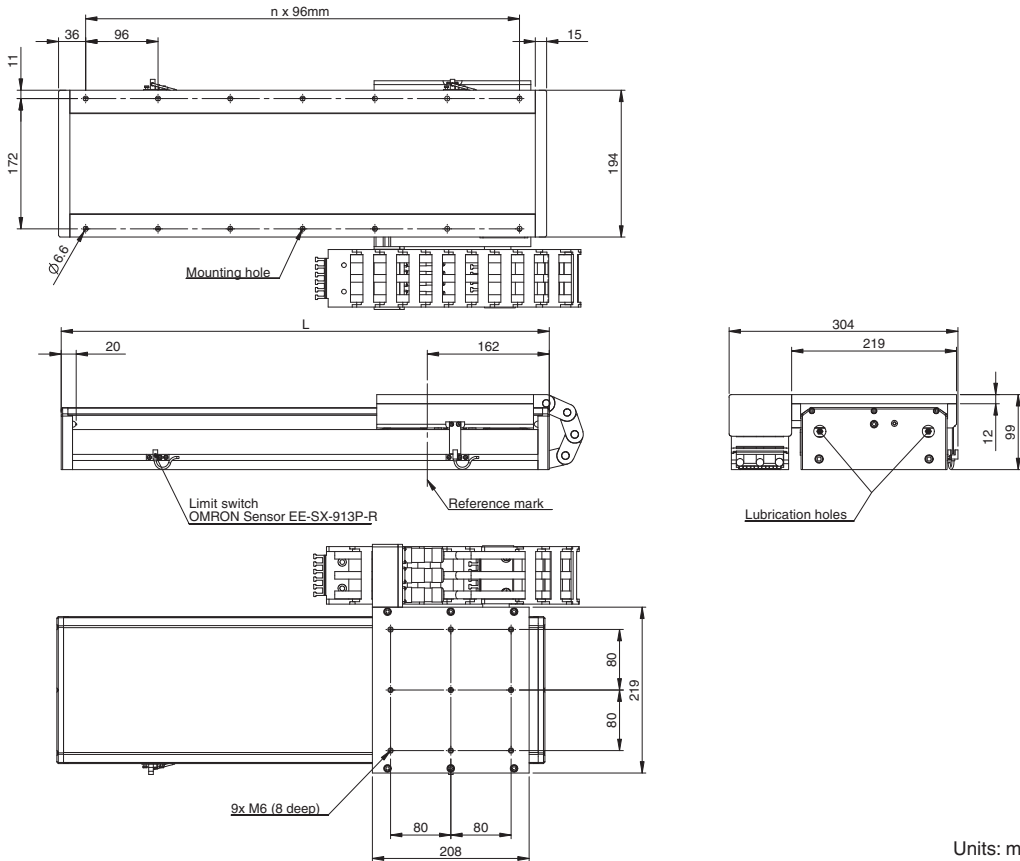

Units: mm

Hall sensor & temperature cable

Cable length 500 mm approx.
Connector D-Sub 9 pins (male)



Pin No.	Name
1	5V
2	Hall U
3	Hall V
4	Hall W
5	GND
6	PTC
7	PTC
8	KTY
9	KTY
Case	Shield

Encoder cable

Cable length 500 mm approx.
Connector D-Sub 15 pins (male)



Pin No.	Signal
1	SDA*
2	SCL*
3	Not used
4	/Ref signal (U ₂)
5	/Cos signal (U ₂)
6	/Sin signal (U ₁)
7	Not used
8	5V
9	0V
10	Not used
11	Not used
12	Ref signal (U ₂)
13	Cos signal (U ₂)
14	Sin signal (U ₁)
15	Inner shield (IS)
Case	Shield

*Reserved. Please do not use

Power cable

Cable length 500 mm approx.
Connector HyperIac
LRR06AMRPN182 (male)

Pin article code: 021.279.1020



Mating connector:
Plug type: LPRA06BFRBN170

Pin No.	Name
1	Phase U
2	Phase V
3	Ground
4	Phase W
5	Not used
6	Not used

R88L-EA-AF-0609-□ (230/ 400 VAC)

Linear axis model	Effective stroke in mm	L in mm	n	Nº of mounting holes	Weigth of moving table including motor coil (kg)	Weigth of the complete axis (kg)
R88L-EA-AF-0609-0158	158	456	4	10	6.7	17.2
R88L-EA-AF-0609-0254	254	552	5	12	6.7	18.9
R88L-EA-AF-0609-0350	350	648	6	14	6.7	20.6
R88L-EA-AF-0609-0446	446	744	7	16	6.7	22.3
R88L-EA-AF-0609-0542	542	840	8	18	6.7	24.1
R88L-EA-AF-0609-0638	638	936	9	20	6.7	25.8
R88L-EA-AF-0609-0734	734	1032	10	22	6.7	27.5
R88L-EA-AF-0609-0830	830	1128	11	24	6.7	29.3
R88L-EA-AF-0609-0926	926	1224	12	26	6.7	31.0
R88L-EA-AF-0609-1022	1022	1320	13	28	6.7	32.7
R88L-EA-AF-0609-1118	1118	1416	14	30	6.7	34.5
R88L-EA-AF-0609-1214	1214	1512	15	32	6.7	36.2
R88L-EA-AF-0609-1310	1310	1608	16	34	6.7	37.9
R88L-EA-AF-0609-1406	1406	1704	17	36	6.7	39.7
R88L-EA-AF-0609-1502	1502	1800	18	38	6.7	41.4
R88L-EA-AF-0609-1598	1598	1896	19	40	6.7	43.1
R88L-EA-AF-0609-1694	1694	1992	20	42	6.7	44.9
R88L-EA-AF-0609-1790	1790	2088	21	44	6.7	46.6
R88L-EA-AF-0609-1886	1886	2184	22	46	6.7	48.3
R88L-EA-AF-0609-1982	1982	2280	23	48	6.7	50.1
R88L-EA-AF-0609-2078	2078	2376	24	50	6.7	51.8

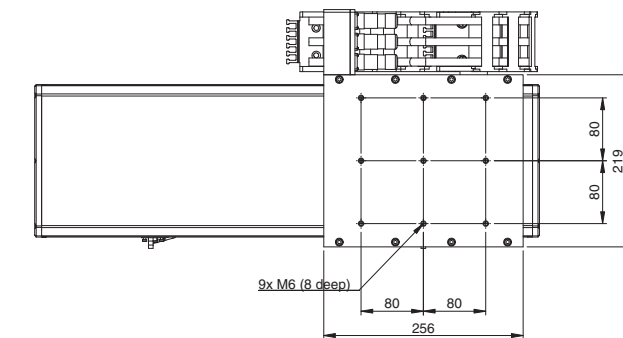
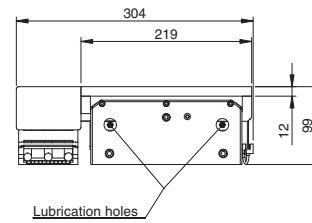
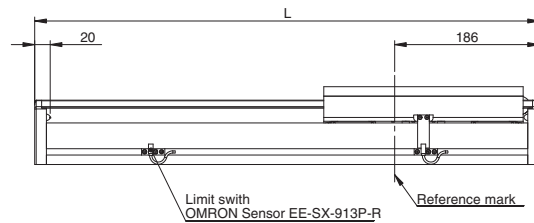
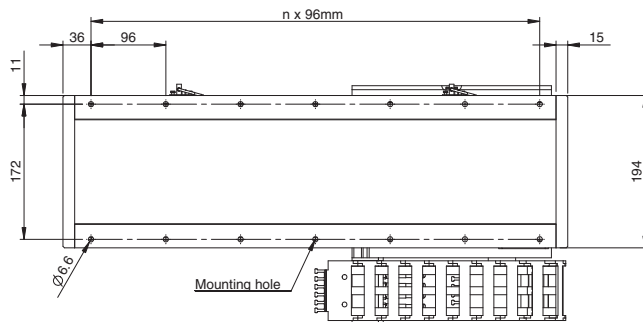

Units: mm

Hall sensor & temperature cable

Cable length 500 mm approx.
Connector D-Sub 9 pins (male)



Pin No.	Name
1	5V
2	Hall U
3	Hall V
4	Hall W
5	GND
6	PTC
7	PTC
8	KTY
9	KTY
Case	Shield

Encoder cable

Cable length 500 mm approx.
Connector D-Sub 15 pins (male)



Pin No.	Signal
1	SDA*
2	SCL*
3	Not used
4	/Ref signal (U ₀)
5	/Cos signal (U ₂)
6	/Sin signal (U ₁)
7	Not used
8	5V
9	0V
10	Not used
11	Not used
12	Ref signal (U ₀)
13	Cos signal (U ₂)
14	Sin signal (U ₁)
15	Inner shield (IS)
Case	Shield

*Reserved. Please do not use

Power cable

Cable length 500 mm approx.
Connector Hypertac
LFR406AMRPN182 (male)
Pin article code: 021.279.1020



Mating connector:
Plug type: LPRA06BFRBN170

Pin No.	Name
1	Phase U
2	Phase V
3	Ground
4	Phase W
5	Not used
6	Not used

R88L-EA-AF-0612-□ (230/ 400 VAC)

Linear axis model	Effective stroke in mm	L in mm	n	Nº of mounting holes	Weight of moving table including motor coil (kg)	Weight of the complete axis (kg)
R88L-EA-AF-0612-0110	110	456	4	10	7.9	18.3
R88L-EA-AF-0612-0206	206	552	5	12	7.9	20.0
R88L-EA-AF-0612-0302	302	648	6	14	7.9	21.7
R88L-EA-AF-0612-0398	398	744	7	16	7.9	23.4
R88L-EA-AF-0612-0494	494	840	8	18	7.9	25.2
R88L-EA-AF-0612-0590	590	936	9	20	7.9	26.9
R88L-EA-AF-0612-0686	686	1032	10	22	7.9	28.6
R88L-EA-AF-0612-0782	782	1128	11	24	7.9	30.4
R88L-EA-AF-0612-0878	878	1224	12	26	7.9	32.1
R88L-EA-AF-0612-0974	974	1320	13	28	7.9	33.8
R88L-EA-AF-0612-1070	1070	1416	14	30	7.9	35.6
R88L-EA-AF-0612-1166	1166	1512	15	32	7.9	37.3
R88L-EA-AF-0612-1262	1262	1608	16	34	7.9	39.0
R88L-EA-AF-0612-1358	1358	1704	17	36	7.9	40.8
R88L-EA-AF-0612-1454	1454	1800	18	38	7.9	42.5
R88L-EA-AF-0612-1550	1550	1896	19	40	7.9	44.2
R88L-EA-AF-0612-1646	1646	1992	20	42	7.9	46.0
R88L-EA-AF-0612-1742	1742	2088	21	44	7.9	47.7
R88L-EA-AF-0612-1838	1838	2184	22	46	7.9	49.4
R88L-EA-AF-0612-1934	1934	2280	23	48	7.9	50.2
R88L-EA-AF-0612-2030	2030	2376	24	50	7.9	52.9

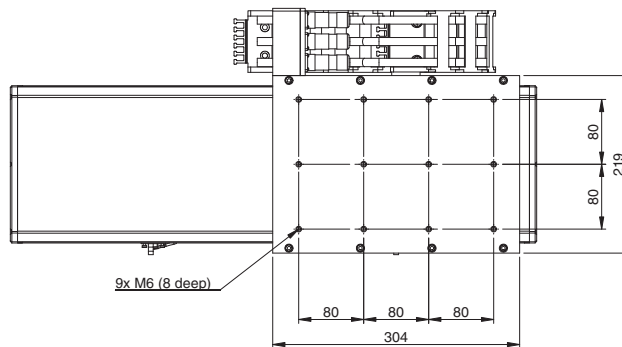
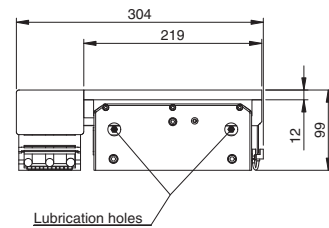
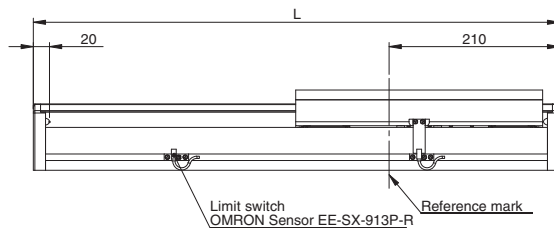
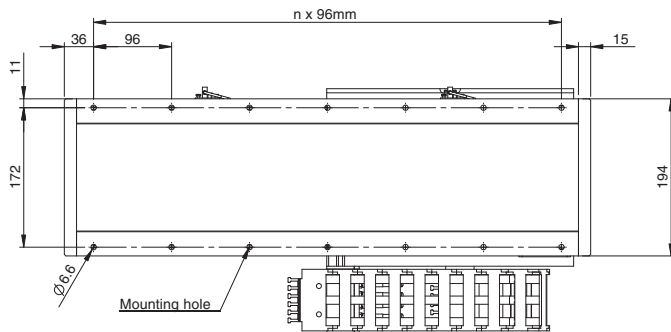

Units: mm

Hall sensor & temperature cable

Cable length 500 mm approx. Connector D-Sub 9 pins (male)



Pin No.	Name
1	5V
2	Hall U
3	Hall V
4	Hall W
5	GND
6	PTC
7	PTC
8	KTY
9	KTY
Case	Shield

Encoder cable

Cable length 500 mm approx. Connector D-Sub 15 pins (male)

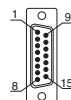

Pin No.	Signal
1	SDA*
2	SCL*
3	Not used
4	/Ref signal (U ₀ -)
5	/Cos signal (U ₂ -)
6	/Sin signal (U ₁ -)
7	Not used
8	5V
9	0V
10	Not used
11	Not used
12	Ref signal (U ₀)
13	Cos signal (U ₂)
14	Sin signal (U ₁)
15	Inner shield (IS)
Case	Shield

*Reserved. Please do not use

Power cable

Cable length 500 mm approx. Connector Hypertac LRR06AMRPN182 (male) Pin article code: 021.279.1020



Pin No.	Name
1	Phase U
2	Phase V
3	Ground
4	Phase W
5	Not used
6	Not used

Mating connector: Plug type: LPR06BFRBN170

R88L-EA-AF-1112-□ (230/ 400 VAC)

Linear axis model	Effective stroke in mm	L in mm	n	N° of mounting holes	Weigth of moving table including motor coil (kg)	Weigth of the complete axis (kg)
R88L-EA-AF-1112-0110	110	456	4	10	13.7	31.9
R88L-EA-AF-1112-0206	206	552	5	12	13.7	35.2
R88L-EA-AF-1112-0302	302	648	6	14	13.7	38.5
R88L-EA-AF-1112-0398	398	744	7	16	13.7	41.7
R88L-EA-AF-1112-0494	494	840	8	18	13.7	45.0
R88L-EA-AF-1112-0590	590	936	9	20	13.7	48.3
R88L-EA-AF-1112-0686	686	1032	10	22	13.7	51.5
R88L-EA-AF-1112-0782	782	1128	11	24	13.7	54.8
R88L-EA-AF-1112-0878	878	1224	12	26	13.7	58.1
R88L-EA-AF-1112-0974	974	1320	13	28	13.7	61.3
R88L-EA-AF-1112-1070	1070	1416	14	30	13.7	64.6
R88L-EA-AF-1112-1166	1166	1512	15	32	13.7	67.9
R88L-EA-AF-1112-1262	1262	1608	16	34	13.7	71.1
R88L-EA-AF-1112-1358	1358	1704	17	36	13.7	74.4
R88L-EA-AF-1112-1454	1454	1800	18	38	13.7	77.7
R88L-EA-AF-1112-1550	1550	1896	19	40	13.7	80.9
R88L-EA-AF-1112-1646	1646	1992	20	42	13.7	84.2
R88L-EA-AF-1112-1742	1742	2088	21	44	13.7	87.5
R88L-EA-AF-1112-1838	1838	2184	22	46	13.7	90.8
R88L-EA-AF-1112-1934	1934	2280	23	48	13.7	94.0
R88L-EA-AF-1112-2030	2030	2376	24	50	13.7	97.3
R88L-EA-AF-1112-2126	2126	2472	25	52	13.7	100.6

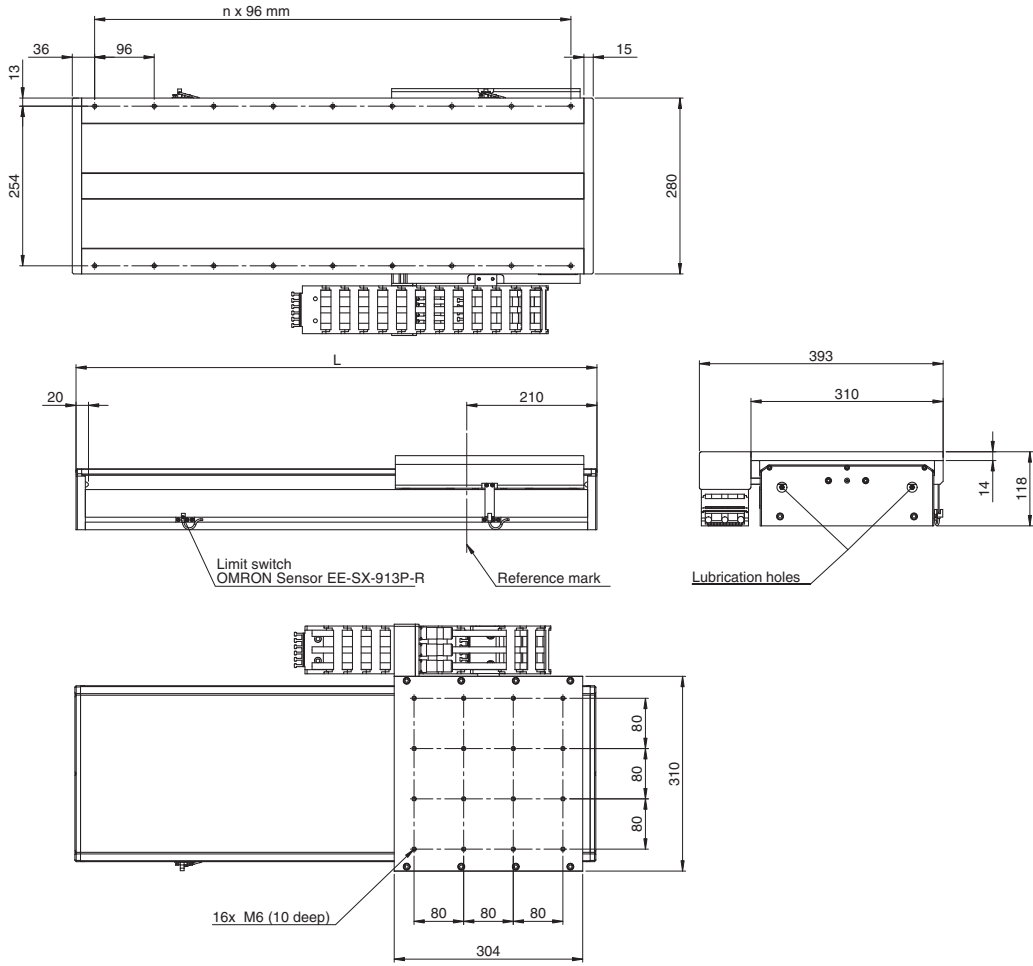

Units: mm

Hall sensor & temperature cable

Cable length 500 mm approx.
Connector D-Sub 9 pins (male)

Pin No.	Name
1	5V
2	Hall U
3	Hall V
4	Hall W
5	GND
6	PTC
7	PTC
8	KTY
9	KTY
Case	Shield

Encoder cable

Cable length 500 mm approx.
Connector D-Sub 15 pins (male)

Pin No.	Signal
1	SDA ⁺
2	SCL ⁺
3	Not used
4	/Ret signal (U _c)
5	/Cos signal (U _c)
6	/Sin signal (U _c)
7	Not used
8	5V
9	0V
10	Not used
11	Not used
12	Ref signal (U _o)
13	Cos signal (U _o)
14	Sin signal (U _o)
15	Inner shield (IS)
Case	Shield

*Reserved. Please do not use

Power cable

Cable length 500 mm approx.
Connector Hypertec
LPRAGAMP1152 (male)
Pin article code: 021.279.1020

Pin No.	Name
1	Phase U
2	Phase V
3	Ground
4	Phase W
5	Not used
6	Not used

Mating connector:
Plug type: LPRAG6BFRBN170

R88L-EA-AF-1115-□ (230/ 400 VAC)

Linear axis model	Effective stroke in mm	L in mm	n	N° of mounting holes	Weight of moving table including motor coil (kg)	Weight of the complete axis (kg)
R88L-EA-AF-1115-0158	158	552	5	12	15.9	37.4
R88L-EA-AF-1115-0254	254	648	6	14	15.9	40.6
R88L-EA-AF-1115-0350	350	744	7	16	15.9	43.9
R88L-EA-AF-1115-0446	446	840	8	18	15.9	47.2
R88L-EA-AF-1115-0542	542	936	9	20	15.9	50.4
R88L-EA-AF-1115-0638	638	1032	10	22	15.9	53.7
R88L-EA-AF-1115-0734	734	1128	11	24	15.9	57.0
R88L-EA-AF-1115-0830	830	1224	12	26	15.9	60.2
R88L-EA-AF-1115-0926	926	1320	13	28	15.9	63.5
R88L-EA-AF-1115-1022	1022	1416	14	30	15.9	66.8
R88L-EA-AF-1115-1118	1118	1512	15	32	15.9	70.0
R88L-EA-AF-1115-1214	1214	1608	16	34	15.9	73.3
R88L-EA-AF-1115-1310	1310	1704	17	36	15.9	76.6
R88L-EA-AF-1115-1406	1406	1800	18	38	15.9	79.8
R88L-EA-AF-1115-1502	1502	1896	19	40	15.9	83.1
R88L-EA-AF-1115-1598	1598	1992	20	42	15.9	86.4
R88L-EA-AF-1115-1694	1694	2088	21	44	15.9	89.6
R88L-EA-AF-1115-1790	1790	2184	22	46	15.9	92.9
R88L-EA-AF-1115-1886	1886	2280	23	48	15.9	96.2
R88L-EA-AF-1115-1982	1982	2376	24	50	15.9	99.4
R88L-EA-AF-1115-2078	2078	2472	25	52	15.9	102.7
R88L-EA-AF-1115-2174	2174	2568	26	54	15.9	106.0

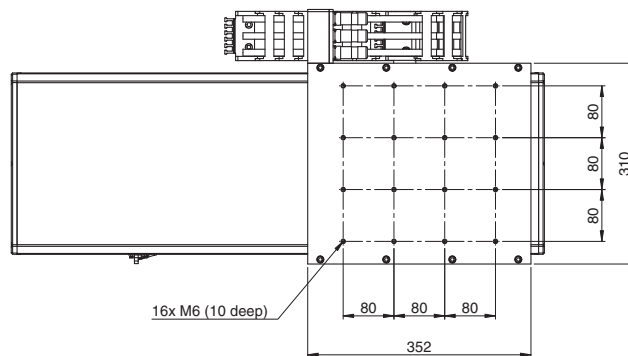
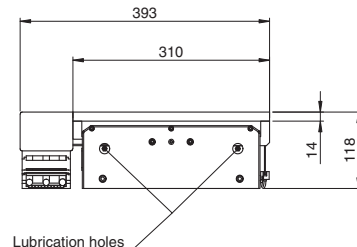
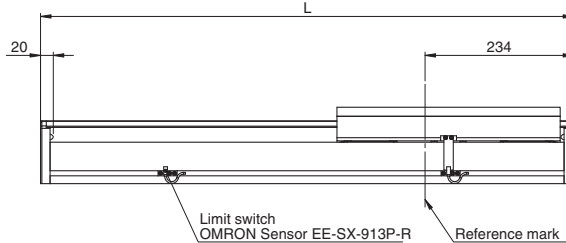
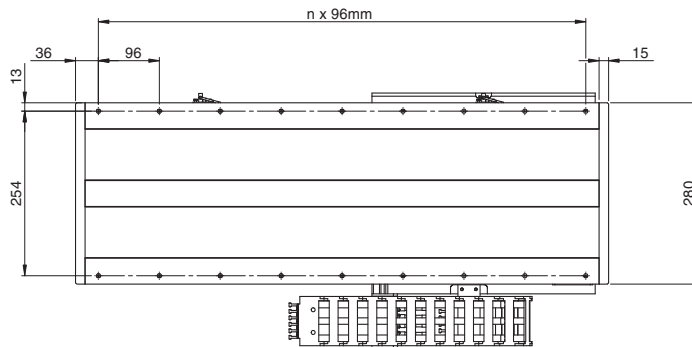

Hall sensor & temperature cable

Cable length 500 mm approx.
Connector D-Sub 9 pins (male)

Pin No.	Name
1	5V
2	Hall U
3	Hall V
4	Hall W
5	GND
6	PTC
7	PTC
8	KTY
9	KTY
Case	Shield

Encoder cable

Cable length 500 mm approx.
Connector D-Sub 15 pins (male)

Pin No.	Signal
1	SDA*
2	SCL*
3	Not used
4	/Ref signal (U ₀)
5	/Cos signal (U ₁)
6	/Sin signal (U ₂)
7	Not used
8	5V
9	0V
10	Not used
11	Not used
12	Ref signal (U ₀)
13	Cos signal (U ₁)
14	Sin signal (U ₂)
15	Inner shield (IS)
Case	Shield

*Reserved. Please do not use

Power cable

Cable length 500 mm approx.
Connector Hypertac
LPR045AMPR182 (male)
Pin article code: 021.279.102

Pin No.	Name
1	Phase U
2	Phase V
3	Ground
4	Phase W
5	Not used
6	Not used

Mating connector:
Plug type: LPR045BFRB170

Units: mm

Optional serial converter unit

Specifications

Serial converter model R88A-		SC01K-E	SC02K-E
Description		Serial converter from 1 Vpp to G5 serial data transmission and with hall sensor input	
Temperature sensor		KTY sensor detection of iron-core motor coil	NTC sensor detection of ironless motor coil
Electrical characteristics	Power supply voltage	5 VDC, max. 250 mA supplied by the drive	
	Standard resolution	Interpolation factor 100 plus quadrature count	
	Max. input frequency	400 kHz 1 Vpp	
	Analog input signals (cos, sin, Ref)	Differential input amplitude: 0.4 V to 1.2 V Input signal level: 1.5 V to 3.5 V	
	Output signals	Position data, hall & temperature sensor information, and alarms	
	Output method	Serial data transmission	
	Transmission cycle	< 42 μs	
Mechanical characteristics	Vibration resistance	98 m/s ² max. (1 to 2500 Hz) in three directions	
	Shock resistance	980 m/s ² , (11 ms) two times in three directions	
Environmental conditions	Operating temperature	0 °C to 55 °C	
	Storage temperature	-20 °C to +80 °C	
	Humidity	20% to 90% relative humidity (without condensation)	

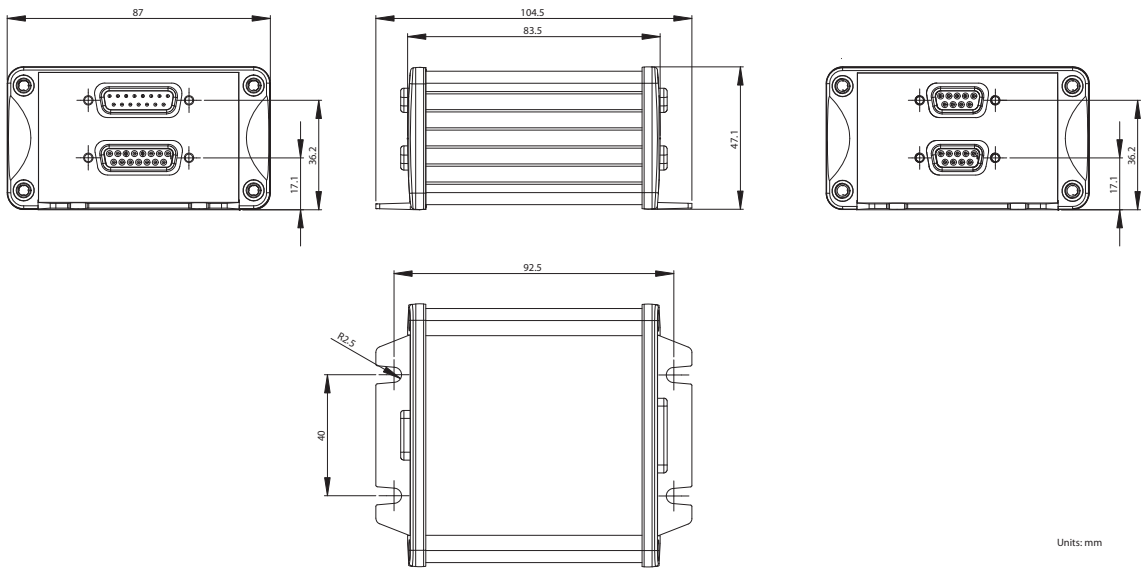

Units:mm

[CN4]
Serial data output to Linear Servo drive

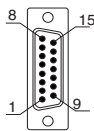

Connector D-Sub 15-pin (male)

Pin No.	Signal
1	PS
2	/PS
3	Not used
4	Not used
5	Not used
6	Not used
7	Not used
8	5V
9	0V
10	Not used
11	Not used
12	Not used
13	Not used
14	Not used
15	Inner shield
Case	Shield

[CN3]
Temperature sensor interface without Hall sensor

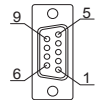

Connector D-Sub 9-pin (female)

Pin No.	Signal
1	Not used
2	Not used
3	Not used
4	Not used
5	Not used
6	PTC
7	PTC
8	KTY/ NTC
9	KTY/NTC
Case	Shield

[CN1]
Encoder input 1Vpp with programmable lines NUMERIK JENA standard

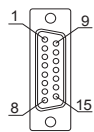

Connector D-Sub 15-pin (female)

Pin No.	Signal
1	SDA*
2	SCL*
3	Not used
4	/Ref signal (U ₀ -)
5	/Cos signal (U ₂ -)
6	/Sin signal (U ₁ -)
7	Not used
8	5V
9	0V
10	Not used
11	Not used
12	Ref signal (U ₀)
13	Cos signal (U ₂)
14	Sin signal (U ₁)
15	Inner shield (IS)
Case	Shield

[CN2]
Hall & temperature sensors interface

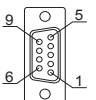

Connector D-Sub 9-pin (female)

Pin No.	Signal
1	5V
2	Hall U
3	Hall V
4	Hall W
5	GND
6	PTC
7	PTC
8	KTY/ NTC
9	KTY/ NTC
Case	Shield

*Reserved. Please do not use

Note: As the 6,7,8,9 pins in the CN2 and CN3 connectors are internally wired, the Temperature sensor can be connected to both connectors. When the Hall sensor is also required, use the same cable for Hall & Temperature signals and the CN2 connector.

Ordering information

(Refer to Servo Drive section)

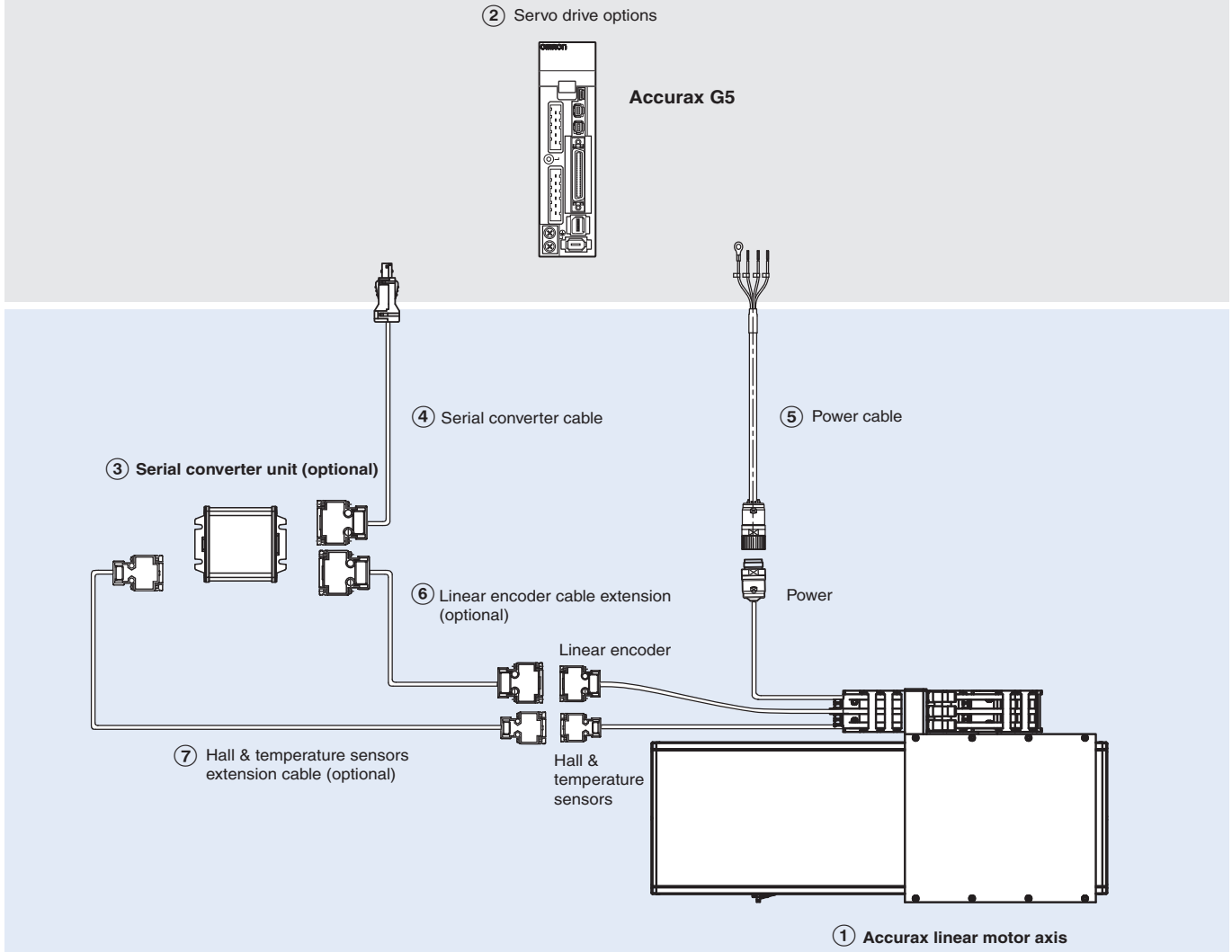

Note: The symbols ①②③... show the recommended sequence to select the servomotor, cables and serial converter for a linear motors system.

Linear motor axis

R88L-EA-AF-□

230 VAC single phase/ 400 VAC three phase

Symbol	Specifications		① Linear motor axis model	② Compatible linear drive			
	Rated force	Peak force		Accurax G5 EtherCAT		Accurax G5 analog/pulse	
				230 V	400 V	230 V	400 V
①②	48 N	120 N	R88L-EA-AF-0303-□	R88D-KN02H-ECT-L	R88D-KN10F-ECT-L	R88D-KT02H-L	R88D-KT10F-L
	96 N	240 N	R88L-EA-AF-0306-□	R88D-KN04H-ECT-L	R88D-KN10F-ECT-L	R88D-KT04H-L	R88D-KT10F-L
	160 N	450 N	R88L-EA-AF-0606-□	R88D-KN08H-ECT-L	R88D-KN15F-ECT-L	R88D-KT08H-L	R88D-KT15F-L
	240 N	675 N	R88L-EA-AF-0609-□	R88D-KN10H-ECT-L	R88D-KN20F-ECT-L	R88D-KT10H-L	R88D-KT20F-L
	320 N	900 N	R88L-EA-AF-0612-□	R88D-KN15H-ECT-L	R88D-KN30F-ECT-L	R88D-KT15H-L	R88D-KT30F-L
	608 N	1800 N	R88L-EA-AF-1112-□	R88D-KN15H-ECT-L	R88D-KN30F-ECT-L	R88D-KT15H-L	R88D-KT30F-L
	760 N	2250 N	R88L-EA-AF-1115-□	R88D-KN15H-ECT-L	R88D-KN30F-ECT-L	R88D-KT15H-L	R88D-KT30F-L

Note: For effective stroke distances available see dimensions section.

Servo drive

② Refer to Accurax G5 servo drive chapter for detailed drive specifications and selection of drive accessories.

Serial Converter unit

Symbol	Specifications	Model
③	Serial converter unit from 1 Vpp to G5 serial data transmission (with KTY sensor detection of iron-core motor coil)	R88A-SC01K-E
	Serial converter unit from 1 Vpp to G5 serial data transmission (with NTC sensor detection of ironless motor coil)	R88A-SC02K-E

Note: If no temperature sensor is needed, then it does not matter which converter you use.

Serial converter cable to servo drive

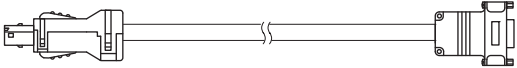
Symbol	Specifications	Model	Appearance	
④	Accurax G5 drive to serial converter cable. (Connectors R88A-CNK41L and DB-15)	1.5 m	R88A-CRKN001-5CR-E	
		3 m	R88A-CRKN003CR-E	
		5 m	R88A-CRKN005CR-E	
		10 m	R88A-CRKN010CR-E	
		15 m	R88A-CRKN015CR-E	
		20 m	R88A-CRKN020CR-E	

Power cable

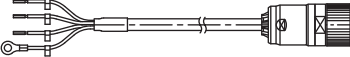
Symbol	Specifications	Model	Appearance	
⑤	For linear motor axis R88L-EA-AF-0303-□ R88L-EA-AF-0306-□	1.5 m	R88A-CAWK001-5S-DE	
		3 m	R88A-CAWK003S-DE	
		5 m	R88A-CAWK005S-DE	
		10 m	R88A-CAWK010S-DE	
		15 m	R88A-CAWK015S-DE	
		20 m	R88A-CAWK020S-DE	
	For linear motor axis R88L-EA-AF-0606-□ R88L-EA-AF-0609-□ R88L-EA-AF-0612-□ R88L-EA-AF-1112-□ R88L-EA-AF-1115-□	1.5 m	R88A-CAWL001-5S-DE	
		3 m	R88A-CAWL003S-DE	
		5 m	R88A-CAWL005S-DE	
		10 m	R88A-CAWL010S-DE	
		15 m	R88A-CAWL015S-DE	
		20 m	R88A-CAWL020S-DE	

Linear encoder cable to serial converter

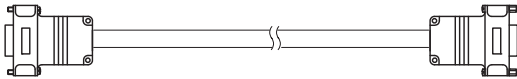
Symbol	Specifications	Model	Appearance	
⑥	Extension cable from linear encoder to serial converter. (Connector DB-15) (This extension cable is optional)	1.5 m	R88A-CFKA001-5CR-E	
		3 m	R88A-CFKA003CR-E	
		5 m	R88A-CFKA005CR-E	
		10 m	R88A-CFKA010CR-E	
		15 m	R88A-CFKA015CR-E	

Hall and temperature sensors cable to serial converter

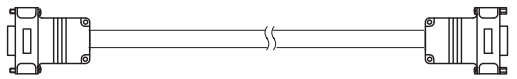
Symbol	Specifications	Model	Appearance	
⑦	Extension cable from hall and temperature sensors to serial converter. (Connector DB-9) (This extension cable is optional)	1.5 m	R88A-CFKB001-5CR-E	
		3 m	R88A-CFKB003CR-E	
		5 m	R88A-CFKB005CR-E	
		10 m	R88A-CFKB010CR-E	
		15 m	R88A-CFKB015CR-E	

Connectors

Specification	Model
Accurax G5 servo drive encoder connector (for CN4)	R88A-CNK41L
Hypertac power cable connector IP67	LPRA-06B-FRBN170

ALL DIMENSIONS SHOWN ARE IN MILLIMETERS.
To convert millimeters into inches, multiply by 0.03937. To convert grams into ounces, multiply by 0.03527.

Frequency inverters

What is your inverter application needs?

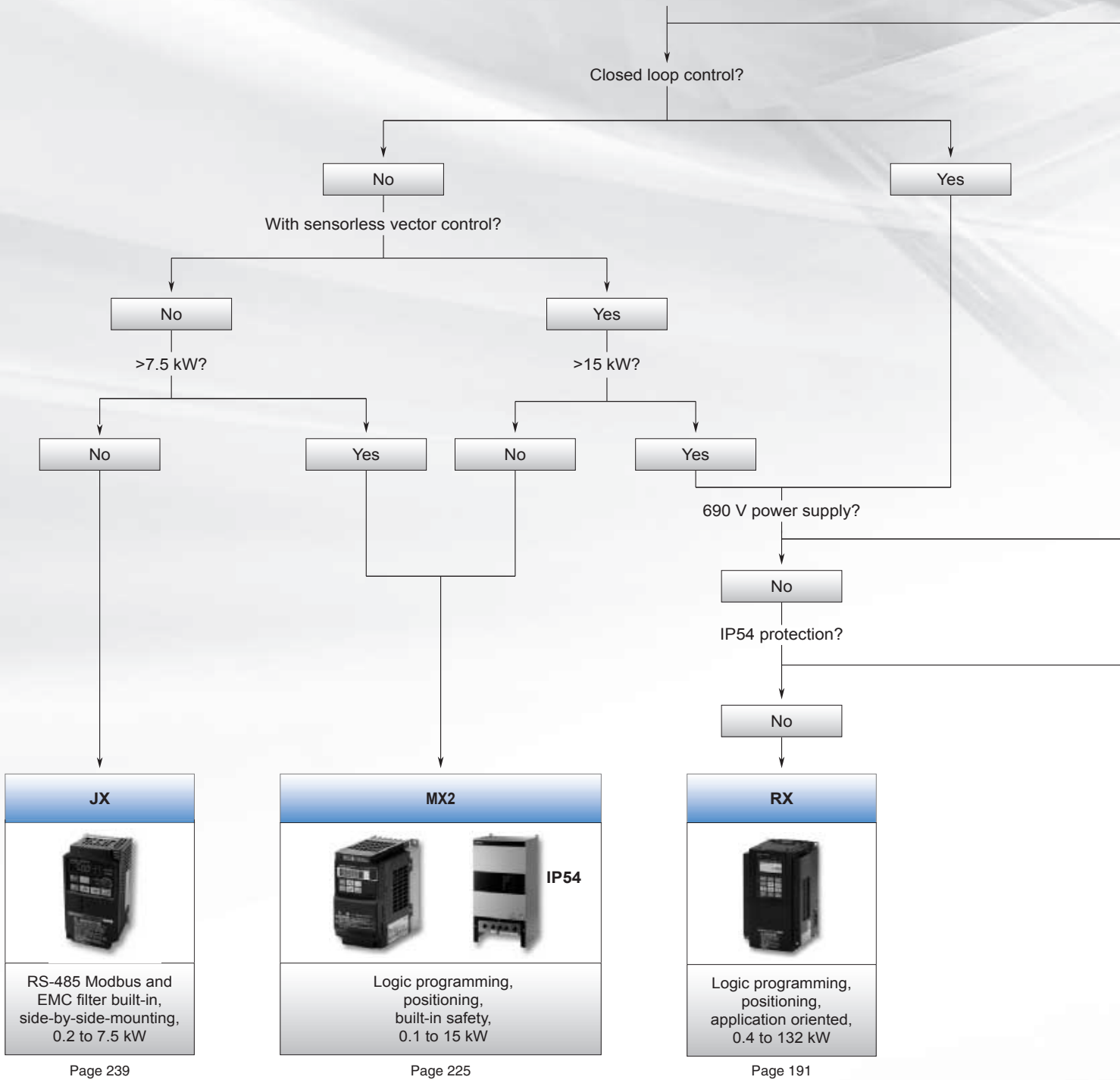
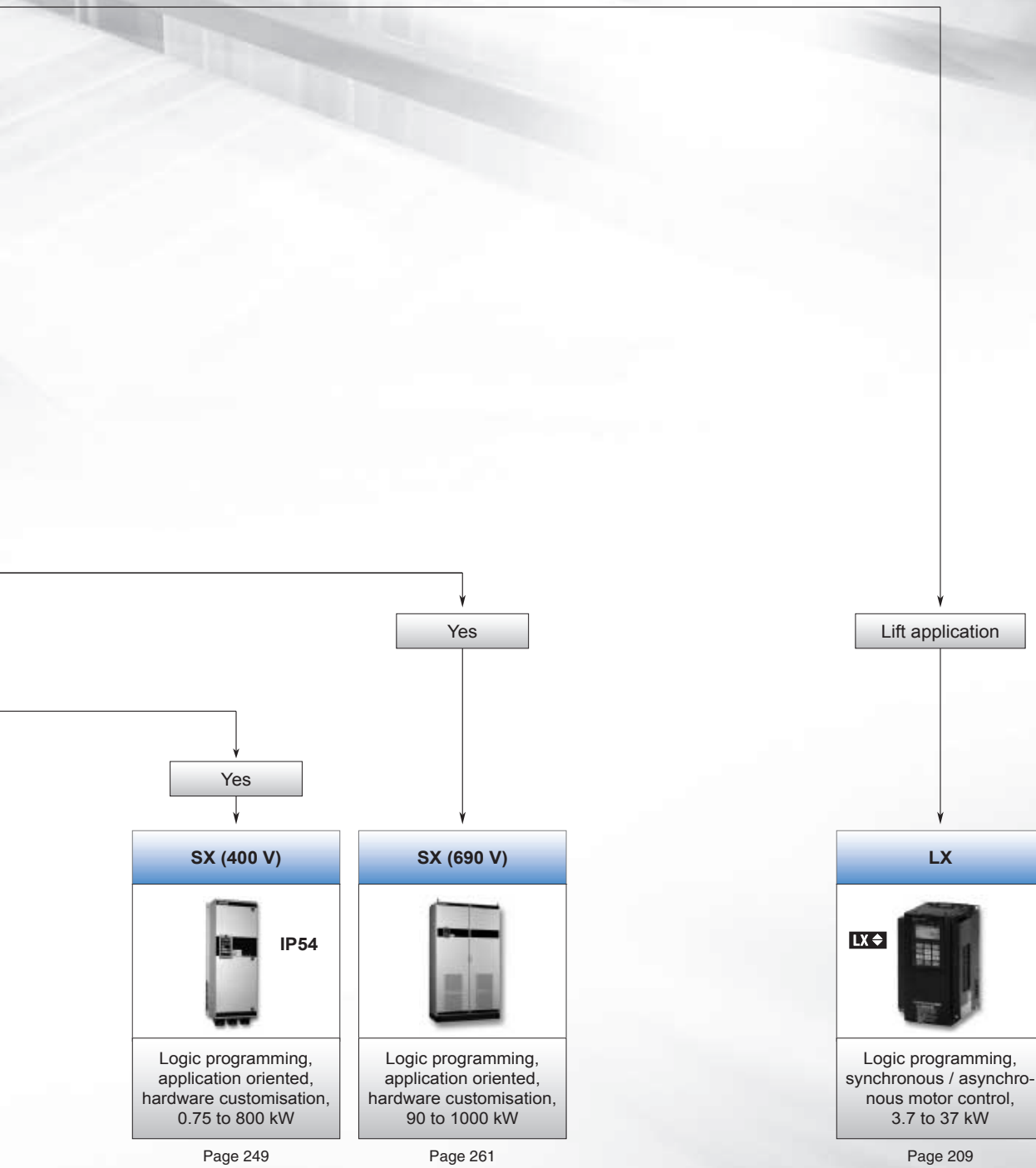

Table of contents

Selection table		190
Inverters	RX	191
	LX	209
	MX2	225
	JX	239
	SX (400V)	249
	SX (690 V)	261







Page 249



Page 261

Page 209

Selection table

Model	RX	LX
		
	Customised to your machine	Lift applications
400 V three-phase	0.4 kW to 132 kW	3.7 kW to 37 kW
200 V three-phase	0.4 kW to 55 kW	4 kW to 37 kW
200 V single-phase	N/A	N/A
Application	High Performance, built-in know-how functionality	Lift control with asynchronous and synchronous motors
Control method	Open and Closed loop for Vector and V/F control	Open and Closed loop vector control and V/F control
Torque features	200% at 0.0 Hz (CLV) 150% at 0.3 Hz (OLV)	150% at 0.0 Hz (CLV) 200% at 0.3 Hz (OLV)
Connectivity	Modbus, DeviceNet, PROFIBUS, MECHATROLINK-II, EtherCAT, CompoNet	Modbus
Logic Programming	Standard Firmware	Standard Firmware
Page	191	209

Model	MX2	JX
	  IP54	
	Born to drives machines	Compact and complete
400 V three-phase	0.4 kW to 15 kW	0.4 kW to 7.5 kW
200 V three-phase	0.1 kW to 15 kW	0.2 kW to 7.5 kW
200 V single-phase	0.1 kW to 2.2 kW	0.2 kW to 2.2 kW
Application	Harmonized motor and machine control	General purpose built-in communications
Control method	Open loop speed and torque control for vector and speed for V/F control	V/F control
Torque features	200% at 0.5 Hz	150% at 3 Hz
Connectivity	Modbus, DeviceNet, PROFIBUS, MECHATROLINK-II, EtherCAT, CompoNet, EtherNet IP	Modbus
Logic Programming	Standard Firmware	N/A
Customisation options	IP54 enclosure	N/A
Page	225	239

Model	SX	
	 IP54	
	400 V	690 V
400 V three-phase	0.55 kW to 800 kW	–
690 V three-phase	–	90 kW to 1,000 kW
Application	High Power Flux vector and variable torque applications	High Power Flux vector and variable torque applications
Control method	Flux vector and V/F control	Flux vector and V/F control
Torque features	120% at 0,0 Hz (CLV) 120% at 0,5 Hz (OLV)	120% at 0,0 Hz (CLV) 120% at 0,5 Hz (OLV)
Connectivity	Modbus, DeviceNet, PROFIBUS, Modbus TCP	Modbus, DeviceNet, PROFIBUS, Modbus TCP
Logic Programming	Standard Firmware	Standard Firmware
Customisation options	Hardware customisation (Main switch, Liquid cooling, 12-pulse rectifier...)	Hardware customisation (Main switch, Liquid cooling, 12-pulse rectifier...)
Page	249	261

RX

Customised to your machine

- Up to 132 kW
- High starting torque in open loop: 200% at 0.3Hz
- Full torque at 0 Hz in closed loop
- Sensor-less and vector closed-loop control
- Double rating VT 120%/1 min and CT 150%/1 min
- Built-in EMC filter
- Built-in logic programmability
- Built-in application functionality
- Positioning functionality
- Automatic energy saving
- Micro-surge voltage suppression
- Modbus RS485 (options for other networks)
- CE, cULus, RoHS

Ratings

- 200 V Class three-phase 0.4 to 55 kW
- 400 V Class three-phase 0.4 to 132 kW



Frequency inverters

System configuration

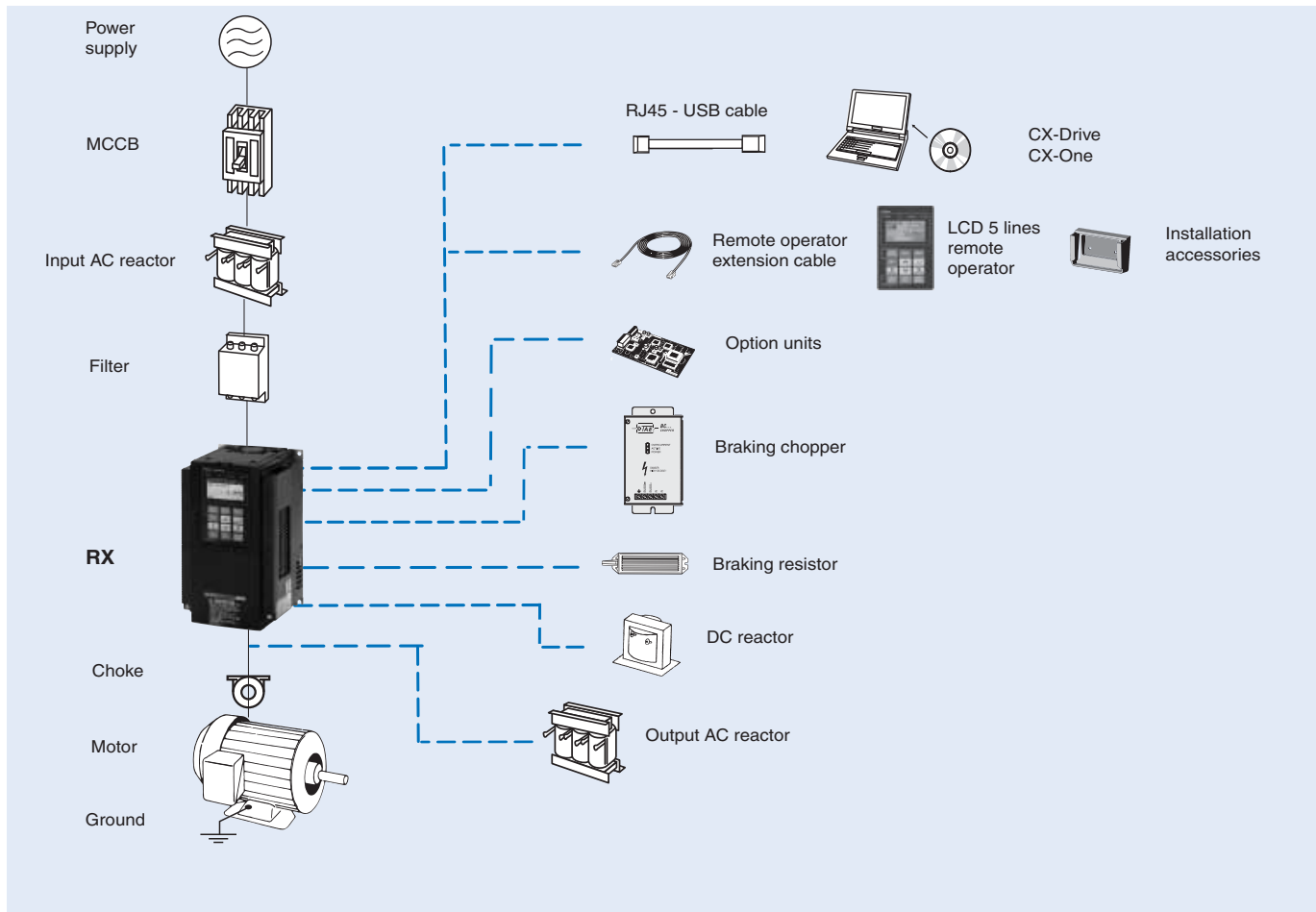

Specifications

Type designation

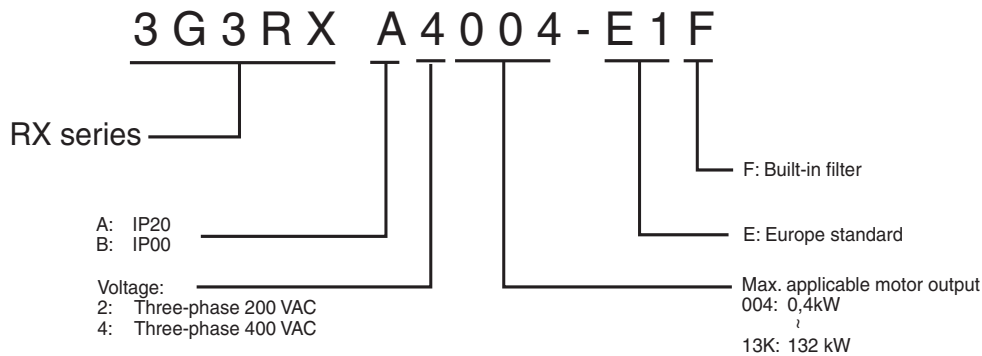

200 V class

Three-phase: 3G3RX-□		A2004	A2007	A2015	A2022	A2037	A2055	A2075	A2110	A2150	A2185	A2220	A2300	A2370	A2450	A2550		
Motor kW ^{*1}		0.4	0.75	1.5	2.2	4.0	5.5	7.5	11	15	18.5	22	30	37	45	55		
Output characteristics	Inverter capacity kVA	200 V		1.0	1.7	2.5	3.6	5.7	8.3	11.0	15.9	22.1	26.3	32.9	41.9	50.2	63.0	76.2
		240 V		1.2	2.0	3.1	4.3	6.8	9.9	13.3	19.1	26.6	31.5	39.4	50.2	60.2	75.6	91.4
Output characteristics	Rated output current (A) at CT	3.0	5.0	7.5	10.5	16.5	24	32	46	64	76	95	121	145	182	220		
	Rated output current (A) at VT	3.7	6.3	9.4	12	19.6	30	44	58	73	85	113	140	169	210	270		
Max. output voltage		Proportional to input voltage: 0..240 V																
Max. output frequency		400 Hz																
Power supply	Rated input voltage and frequency	3-phase 200..240 V 50/60 Hz																
	Allowable voltage fluctuation	-15%..+10%																
	Allowable frequency fluctuation	5%																
Braking	Regenerative braking	Internal BRD circuit (external discharge resistor)																
	Minimum connectable resistance	50	50	35	35	35	16	10	10	7.5	7.5	5	External regenerative braking unit					
Protective structure		IP20																
Cooling method		Forced air cooling																

*1 Based on a standard 3-Phase standard motor.

400V class

Three-phase: 3G3RX-□		A4004	A4007	A4015	A4022	A4040	A4055	A4075	A4110	A4150	A4185	A4220	A4300	A4370	A4450	A4550	B4750	B4900	B411K	B413K		
Motor kW ^{*1}		0.4	0.75	1.5	2.2	4.0	5.5	7.5	11	15	18.5	22	30	37	45	55	75	90	110	132		
Output characteristics	Inverter capacity kVA	400 V		1.0	1.7	2.5	3.6	6.2	9.7	13.1	17.3	22.1	26.3	33.2	40.1	51.9	63.0	77.6	103.2	121.9	150.3	180.1
		480 V		1.2	2.0	3.1	4.3	7.4	11.6	15.8	20.7	26.6	31.5	39.9	48.2	62.3	75.6	93.1	123.8	146.3	180.4	216.1
Output characteristics	Rated output current (A) at CT	1.5	2.5	3.8	5.3	9.0	14	19	25	32	38	48	58	75	91	112	149	176	217	260		
	Rated output current (A) at VT	1.9	3.1	4.8	6.7	11.1	16	22	29	37	43	57	70	85	105	135	160	195	230	290		
Max. output voltage		Proportional to input voltage: 0..480 V																				
Max. output frequency		400 Hz																				
Power supply	Rated input voltage and frequency	3-phase 380..480 V 50/60 Hz																				
	Allowable voltage fluctuation	-15%..+10%																				
	Allowable frequency fluctuation	5%																				
Braking	Regenerative braking	Internal BRD circuit (external discharge resistor)																				
	Minimum connectable resistance	100	100	100	100	70	70	35	35	24	24	20	External regenerative braking unit									
Protective structure		IP20															IP00					
Cooling method		Forced air cooling																				

*1 Based on a standard 3-Phase standard motor.

Common specifications

Model number 3G3RX□		Specifications	
Control functions	Control methods	Phase-to-phase sinusoidal pulse with modulation PWM (Sensorless vector control, close loop vector with motor feedback, V/F)	
	Output frequency range	0.10 to 400.00 Hz	
	Frequency precision	Digital set value: ±0.01% of the max. frequency Analogue set value: ±0.2% of the max. frequency (25 ±10 °C)	
	Resolution of frequency set value	Digital set value: 0.01 Hz Analog input: 12 bit	
	Resolution of output frequency	0.01Hz	
	Starting torque	150%/0.3 Hz (under sensor-less vector control or sensor-less vector control at 0 Hz) 200%/Torque at 0 Hz (under sensor-less vector control at 0Hz, when a motor size one rank lower than specified is connected)	
	Overload capability	150%/60s, 200%/3s for CT; 120%/60s VT	
	Frequency set value	0 to 10 VDC (10 KΩ), -10 to 10 VDC (10 KΩ), 4 to 20 mA (100 Ω), RS485 Modbus, Network options	
	V/f Characteristics	V/f optionally changeable at base frequencies of 30 to 400 Hz, V/f braking constant torque, reduction torque, sensor-less vector control, sensor-less vector control at 0 Hz	
Functionality	Inputs signals	8 terminals, NO/NC switchable, sink/source logic switchable [Terminal function] 8 functions can be selected from among 61. Reverse (RV), Multi-step speed setting binary 1 (CF1), Multi-step speed setting binary 2 (CF2), Multi-step speed setting binary 3 (CF3), Multi-step speed setting binary 4 (CF4), Jogging (JG), DC injection braking (DB), 2nd control (SET), 2-step acceleration/deceleration (2CH), Free-run stop (FRS), External trip (EXT), USP function (USP), Commercial switching (CS), Soft lock (SFT), Analog input switching (AT), 3rd control (SET3), Reset (RS), 3-wire start (STA), 3-wire stop (STP), 3-wire forward/reverse (F/R), PID enabled/disabled (PID), PID integral reset (PIDC), Control gain switching (CAS), UP/DWN function accelerated (UP), UP/DWN function decelerated (DWN), UP/DWN function data clear (UDC), Forced operator (OPE), Multi-step speed setting bit 1 (SF1), Multi-step speed setting bit 2 (SF2), Multi-step speed setting bit 3 (SF3), Multi-step speed setting bit 4 (SF4), Multi-step speed setting bit 5 (SF5), Multi-step speed setting bit 6 (SF6), Multi-step speed setting bit 7 (SF7), Overload limit switching (OLR), Torque limit enabled (TL), Torque limit switching 1 (TRQ1), Torque limit switching 2 (TRQ2), P/PI switching (PPI), Brake confirmation (BOK), Orientation (ORT), LAD cancel (LAC), Position deviation clear (PCLR), Pulse train position command input permission (STAT), Frequency addition function (ADD), Forced terminal block (F-TM), Torque reference input permission (ATR), Integrated power clear (KHC), Servo ON (SON), Preliminary excitation (FOC), Analog command on hold (AHD), Position command selection 1 (CP1), Position command selection 2 (CP2), Position command selection 3 (CP3), Zero return limit signal (ORL), Zero return startup signal (ORG), Forward driving stop (FOT), Reverse driving stop (ROT), Speed/Position switching (SPD), Pulse counter (PCNT), Pulse counter clear (PCC), No allocation (no)	
	Output signals	5 open collector output terminals: NO/NC switchable, sink/source logic switchable 1 relay (SPDT contact) output terminal: NO/NC switchable [Terminal function] 6 functions can be selected from among 45. Signal during RUN (RUN), Constant speed arrival signal (FA1), Over set frequency arrival signal (FA2), Overload warning (OL), Excessive PID deviation (OD), Alarm signal (AL), Set-frequency-only arrival signal (FA3), Overtorque (OTQ), Signal during momentary power interruption (IP), Signal during undervoltage (UV), Torque limit (TRQ), RUN time exceeded (RNT), Power ON time exceeded (ONT), Thermal warning (THM), Brake release (BRK), Brake error (BER), 0-Hz signal (ZS), Excessive speed deviation (DSE), Position ready (POK), Set frequency exceeded 2 (FA4), Set frequency only 2 (FA5), Overload warning 2 (OL2), Analog FV disconnection detection (FVDC), Analog FI disconnection detection (FIDc), Analog FE disconnection detection (FEDc), PID FB status output (FBV), Network error (NDc), Logic operation output 1 (LOG1), Logic operation output 2 (LOG2), Logic operation output 3 (LOG3), Logic operation output 4 (LOG4), Logic operation output 5 (LOG5), Logic operation output 6 (LOG6), Capacitor life warning (WAC), Cooling fan life warning (WAF), Starting contact signal (FR), Fin overheat warning (OHF), Light load detection signal (LOC), Operation ready (IRDY), Forward run (FWR), Reverse run (RVR), Fatal fault (MJA), Window comparator FV (WCFV), Window comparator FI (WCFI), Window comparator FE (WCFE), Alarm codes 0 to 3 (AC0 to AC3)	
	Standard functions	V/f free setting (7), Upper/lower frequency limit, Frequency jump, Curve acceleration/deceleration, Manual torque boost level/break, Energy-saving operation, Analog meter adjustment, Starting frequency, Carrier frequency adjustment, Electronic thermal function, (free setting available), External start/end (frequency/rate), Analog input selection, Trip retry, Restart during momentary power interruption, Various signal outputs, Reduced voltage startup, Overload limit, Initialization value setting, Automatic deceleration at power-off, AVR function, Automatic acceleration/deceleration, Auto tuning (Online/Offline), High torque multi-motor operation control (sensor-less vector control of two monitors with one inverter)	
	Analogue inputs	Analogue inputs 0 to 10 V and -10 to 10 V (10 KΩ), 4 to 20 mA (100 Ω)	
	Analogue outputs	Analogue voltage output, Analogue current output, Pulse train output	
	Accel/Decel times	0.01 to 3600.0 s (line/curve selection)	
	Display	Status indicator LED's Run, Program, Power, Alarm, Hz, Amps, Volts, % Digital operator: Available to monitor 23 items, output current, output frequency...	
	Protection functions	Motor overload protection	Electronic Thermal overload relay and PTC thermistor input
		Instantaneous overcurrent	200% of rated current for 3 seconds
		Overload	150% for 1 minute
Overvoltage		800 V for 400 V type and 400 V for 200 V type	
Momentary power loss		Decelerates to stop with DC bus controlled, coast to stop	
Cooling fin overheat		Temperature monitor and error detection	
Stall prevention level		Stall prevention during acceleration, deceleration and constant speed	
Ground fault		Detection at power on	
Ambient conditions	Power charge indication	On when voltage between P and N is higher than 45V	
	Degree of protection	IP20 / IP00	
	Ambient humidity	90% RH or less (without condensation)	
	Storage temperature	-20°C..+65°C (short-term temperature during transportation)	
	Ambient temperature	-10°C to 50°C	
	Installation	Indoor (no corrosive gas, dust, etc.)	
	Installation height	Max. 1000 m	
Vibration	3G3RX-A□004 to A□220, 5.9 m/s ² (0.6G), 10 to 55 Hz 3G3RX-A□300 to B□13K, 2.94 m/s ² (0.3G), 10 to 55 Hz		

Dimensions

Figure 1

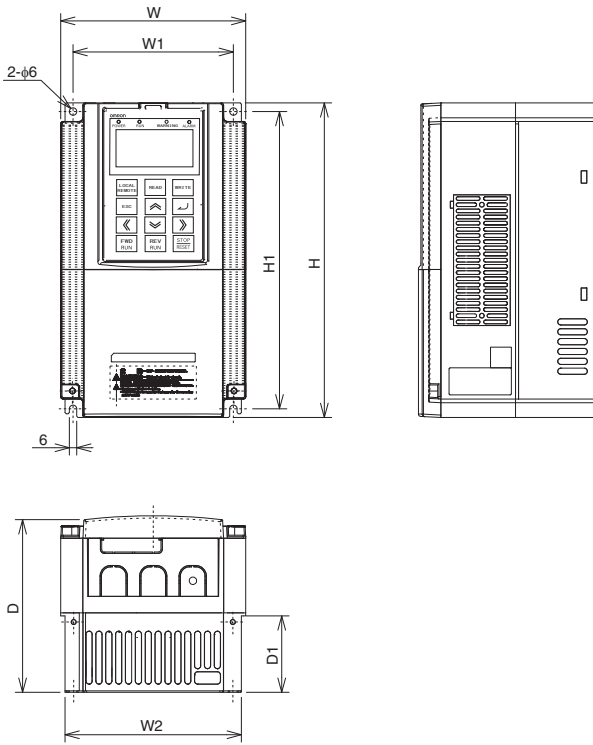

Figure 2

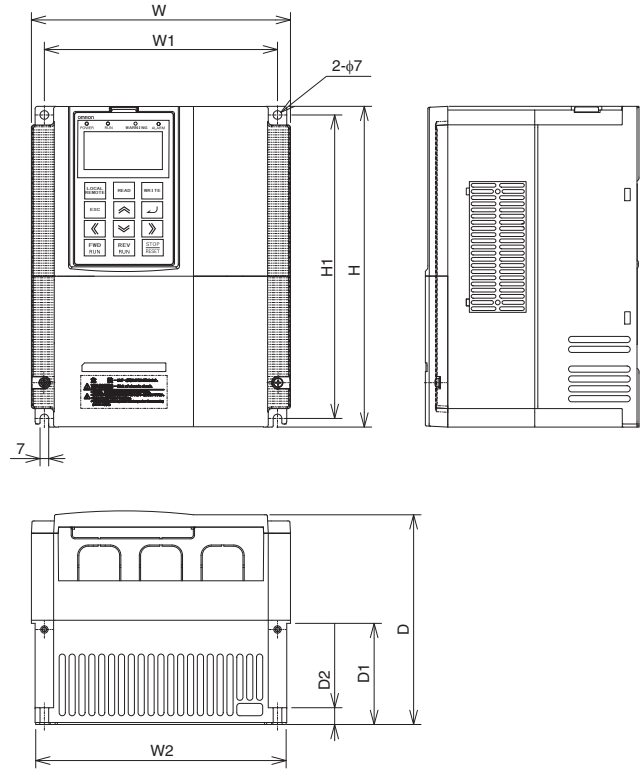

Figure 3

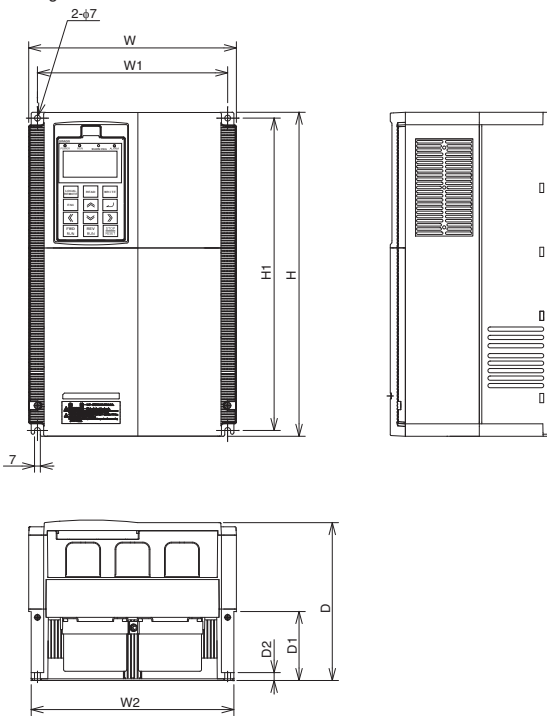

Figure 4

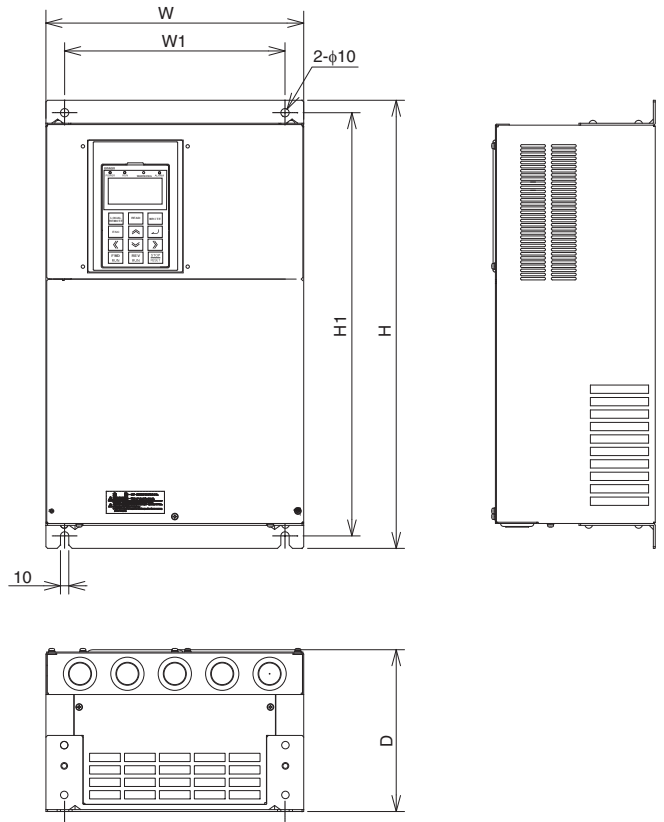
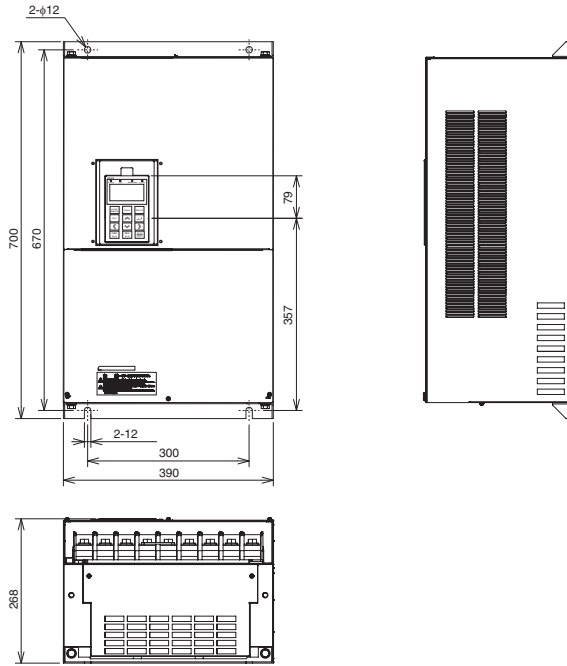

Figure 5



Frequency inverters

Voltage class	Inverter model 3G3RX□	Figure	Dimensions in mm								Weight (kg)
			W	W1	W2	H	H1	D	D1	D2	
Three-phase 200 V	A2004	1	150	130	143	255	241	140	62	-	3.5
	A2007										
	A2015										
	A2022										
	A2037										
	A2055	2	210	189	203	260	246	170	82	13.6	6
	A2075										
	A2110										
	A2150	3	250	229	244	390	376	190	83	9.5	14
	A2185										
	A2220										
	A2300										
	A2370										
	A2450										
A2550											
Three-phase 400 V	A4004	1	150	130	143	255	241	140	62	-	3.5
	A4007										
	A4015										
	A4022										
	A4040										
	A4055	2	210	189	203	260	246	170	82	13.6	6
	A4075										
	A4110										
	A4150	3	250	229	244	390	376	190	83	9.5	14
	A4185										
	A4220										
	A4300										
	A4370										
	A4450										
	A4550										
	B4750	5	390	300	-	700	670	268	-	-	60
	B4900										
	B411K		480	380	-	740	710	270	-	-	80
B413K											

Rasmi filters

Footprint dimensions

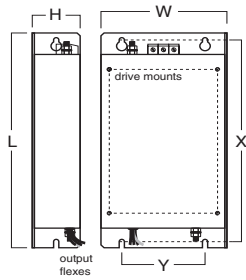

Book type dimensions

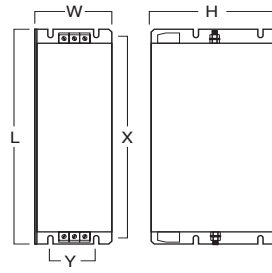

Block type dimensions

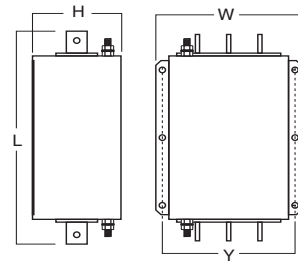

Voltage	Inverter model	Rasmi model	Dimensions						Filter type	Weight (kg)
			L	W	H	X	Y	M		
3x200 V	3G3RX-A2004	AX-FIR2018-RE	305	152	45	290	110	M5	Footprint	2.0
	3G3RX-A2007									
	3G3RX-A2015									
	3G3RX-A2022									
	3G3RX-A2037									
	3G3RX-A2055	AX-FIR2053-RE	320	212	56	296	189	M6	2.5	
	3G3RX-A2075									
	3G3RX-A2110									
	3G3RX-A2150	AX-FIR2110-RE	455	110	240	414	80	-	Book type	8.0
	3G3RX-A2185									
	3G3RX-A2220									
	3G3RX-A2300									
	3G3RX-A2370	AX-FIR2145-RE	386	260	135	240	235	-	Block type	13
	3G3RX-A2450									
3G3RX-A2550										
3G3RX-A2550	AX-FIR3320-RE	386	260	135	240	235	-	Block type	13.2	
3G3RX-A4004	AX-FIR3010-RE									305
3G3RX-A4007										
3G3RX-A4015										
3G3RX-A4022										
3G3RX-A4040										
3G3RX-A4055	AX-FIR3030-RE	312	212	50	296	189	M6	Footprint	2.2	
3G3RX-A4075										
3G3RX-A4110										
3G3RX-A4150	AX-FIR3053-RE	451	252	60	435	229	M6	Footprint	4.5	
3G3RX-A4185										
3G3RX-A4220										
3G3RX-A4300										
3G3RX-A4300	AX-FIR3064-RE	598	310	70	578	265	M8	Footprint	7.0	
3G3RX-A4370										
3G3RX-A4370	AX-FIR3100-RE	486	110	240	414	80	-	Book type	8.0	
3G3RX-A4450										
3G3RX-A4550										
3G3RX-A4450										
3G3RX-B4750	AX-FIR3250-RE	386	260	135	240	235	-	Block type	13.0	
3G3RX-B4900										
3G3RX-B411K	AX-FIR3320-RE	386	260	135	240	235	-	Block type	13.2	
3G3RX-B413K										

Input AC Reactor

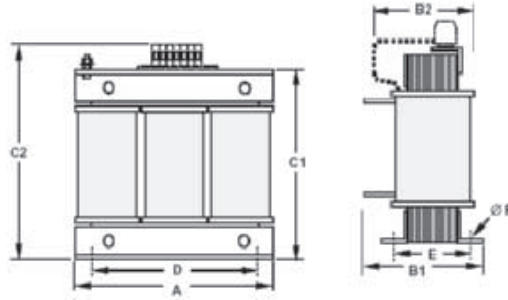

Voltage	Reference	Dimensions								Weight (kg)				
		A	B1	B2	C1	C2	D	E	F					
200 V	AX-RAI02800100-DE	120	-	80	-	120	80	62	5.5	2.35				
	AX-RAI00880200-DE			85		190		55		5.5				
	AX-RAI00350335-DE	180		105		205	85	6		6.5				
	AX-RAI00180670-DE			205		85	11.7							
	AX-RAI00091000-DE			240		130	-			210	-	200	75	16.0
	AX-RAI00071550-DE			240		130	-			210	-	200	75	16.0
400 V	AX-RAI07700050-DE	120	-	70	-	120	80	52	5.5	1.78				
	AX-RAI03500100-DE			80		62		2.35						
	AX-RAI01300170-DE			80		62		2.5						
	AX-RAI00740335-DE	180		85		190	55	6		5.5				
	AX-RAI00360500-DE			105		205	85			6.5				
	AX-RAI00290780-DE			110		275	200			75	11.7			
	AX-RAI00191150-DE			110		275	200			75	16.0			
	AX-RAI00111850-DE	Pending												
	AX-RAI00072700-DE	Pending												

Frequency inverters

DC reactor

Figure 1

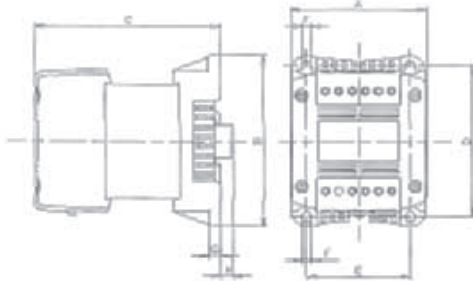
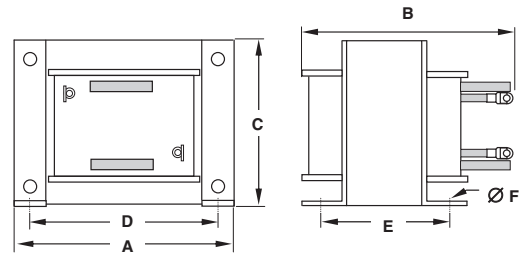
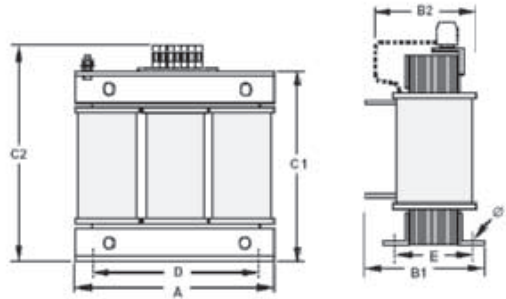

Figure 2



200 V											400 V																				
Reference AX-RC	Fig	Dimensions								kg	Reference AX-RC	Fig	Dimensions								kg										
		A	B	C	D	E	F	G	H				A	B	C	D	E	F	G	H											
21400016-DE	1	84	113	96	101	66	5	7.5	2	1.22	43000020-DE	1	84	113	96	101	66	5	7.5	2	1.22										
10700032-DE				105							14000047-DE				105						1.60										
06750061-DE				105							10100069-DE				116						1.95										
03510093-DE				116							06400116-DE				108						135	133	120	82	6.5	9.5	3.70				
02510138-DE		150	177	182.6	160	115	7	2	-		3.20		04410167-DE	1	120	152	136	135	94	7	9.5	-	5.20								
01600223-DE											108		135				124						120	82	6.5	9.5	3.20	04410167-DE	136	5.20	
01110309-DE											120		152				136						135	94	7	-	5.20	03350219-DE	146	6.00	
00840437-DE											146		02330307-DE				160						6.00								
00590614-DE											160		01750430-DE				177						11.4	01750430-DE	182.6	160	115	7	2	-	11.4
00440859-DE											182.6		01200644-DE				14.3						14.3	01200644-DE	14.3	01200644-DE	14.3	01200644-DE	17.0		
00301275-DE	2	195	161	162.5	185	88	10	-	-	17.0	00920797-DE	2	195	161	162.5	185	88	10	-	-	17.0										
00231662-DE										196	123										25.5	00741042-DE	188	25.5							
00192015-DE										188	109										34.0	00611236-DE	198	34.0							
00162500-DE										198	119										38.0	00501529-DE	228	38.0							
00133057-DE		228	149	42.0	00372094-DE	228	42.0	Pending																							

Output AC reactor



Reference	Dimensions								Weight kg
	A	B1	B2	C1	C2	D	E	F	
AX-RAO11500026-DE	120	-	70	-	120	80	52	5.5	1.78
AX-RAO07600042-DE	120	-	70	-	120	80	52	5.5	1.78
AX-RAO04100075-DE	120	-	80	-	120	80	62	5.5	2.35
AX-RAO03000105-DE	120	-	80	-	120	80	62	5.5	2.35
AX-RAO01830160-DE	180	-	85	-	190	140	55	6	5.5
AX-RAO01150220-DE	180	-	85	-	190	140	55	6	5.5
AX-RAO00950320-DE	180	-	85	-	205	140	55	6	6.5
AX-RAO00630430-DE	180	-	95	-	205	140	65	6	9.1
AX-RAO00490640-DE	180	-	95	-	205	140	65	6	9.1
AX-RAO00390800-DE	240	-	110	-	275	200	75	6	16.0
AX-RAO00330950-DE	240	-	110	-	275	200	75	6	16.0
AX-RAO00251210-DE	240	-	110	-	275	200	75	6	16.0
AX-RAO00191450-DE	240	-	120	-	275	200	85	6	18.6
AX-RAO00161820-DE	240	-	150	-	275	200	110	6	27.0
AX-RAO00132200-DE	240	165	-	210	-	200	110	6	27.0
AX-RAO16300038-DE	120	-	70	-	120	80	52	5.5	1.78
AX-RAO11800053-DE	120	-	80	-	120	80	52	5.5	2.35
AX-RAO07300080-DE	120	-	80	-	120	80	62	5.5	2.35
AX-RAO04600110-DE	180	-	85	-	190	140	55	6	5.5
AX-RAO03600160-DE	180	-	85	-	205	140	55	6	6.5
AX-RAO02500220-DE	180	-	95	-	205	140	55	6	9.1
AX-RAO02000320-DE	180	-	105	-	205	140	85	6	11.7
AX-RAO01650400-DE	240	-	110	-	275	200	75	6	16.0
AX-RAO01300480-DE	240	-	120	-	275	200	85	6	18.6
AX-RAO01030580-DE	240	-	120	-	275	200	85	6	18.6
AX-RAO00800750-DE	240	-	120	-	275	200	110	6	27.0
AX-RAO00680900-DE	240	-	150	-	275	200	110	6	27.0
AX-RAO00531100-DE	240	-	150	-	275	200	110	6	27.0
AX-RAO00401490-DE	300	-	165	-	320	200	125	6	44.0
AX-RAO00331760-DE	300	-	165	-	320	200	125	6	44.0
AX-RAO00262170-DE	360	230	-	300	-	300	145	8	70.0
AX-RAO00212600-DE	360	230	-	300	-	300	145	8	70.0

Chokes

Reference	D diameter	Motor KW	Dimensions						Weight kg
			L	W	H	X	Y	m	
AX-FER2102-RE	21	< 2.2	85	22	46	70	-	5	0.1
AX-FER2515-RE	25	< 15	105	25	62	90	-	5	0.2
AX-FER5045-RE	50	< 45	150	50	110	125	30	5	0.7
AX-FER6055-RE	60	> 45	200	65	170	180	45	6	1.7

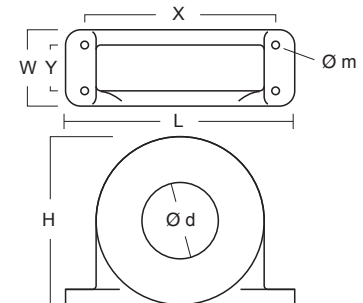

Braking unit dimensions

Reference	Dimensions					
	B	B1	H	H1	T	S
AX-BCR4015045-TE	82.5	40.5	150	138	220	6
AX-BCR4017068-TE						
AX-BCR2035090-TE	130	64.5	205	193	208	6
AX-BCR2070130-TE						
AX-BCR4035090-TE						
AX-BCR4070130-TE						
AX-BCR4090240-TE	131	64.5	298	280	300	9

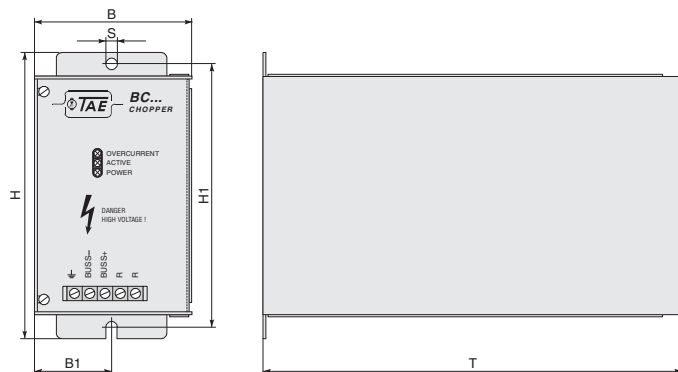

Resistor dimensions

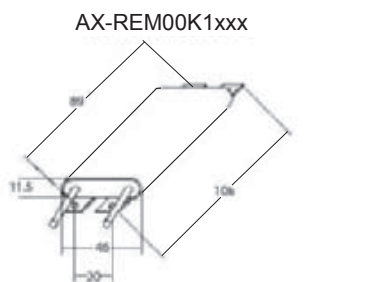

Fig 3

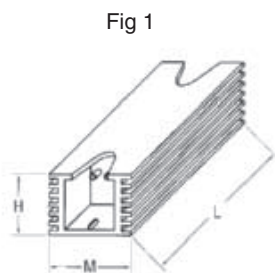

Fig 4

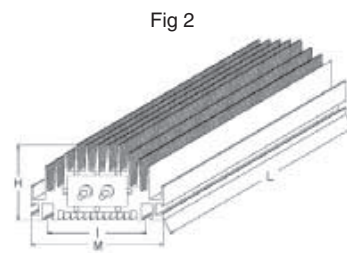
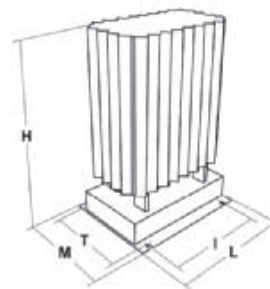
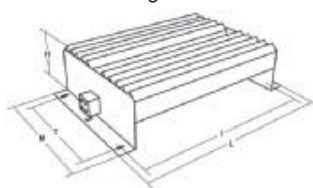
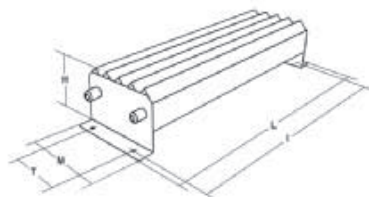
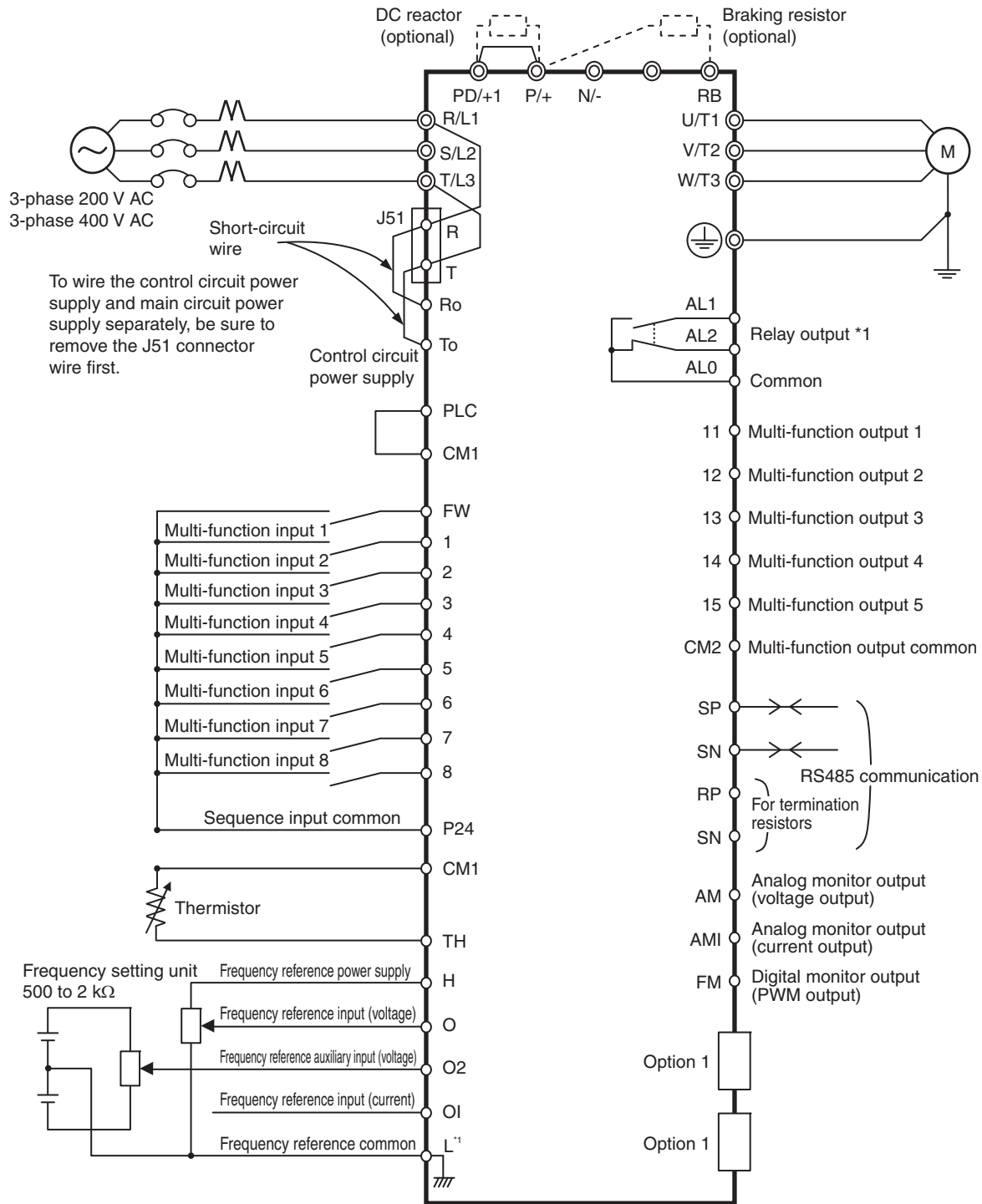

Fig 5



Type	Fig.	Dimensions					Weight
		L	H	M	I	T	kg
AX-REM00K2070-IE	1	105	27	36	94	-	0.2
AX-REM00K2120-IE							
AX-REM00K2200-IE							
AX-REM00K4075-IE							
AX-REM00K4035-IE							
AX-REM00K4030-IE							
AX-REM00K5120-IE							
AX-REM00K6100-IE	2	200	62	100	74	-	1.41
AX-REM00K6035-IE							
AX-REM00K9070-IE							
AX-REM01K9070-IE	3	365	73	105	350	70	4
AX-REM01K9017-IE							
AX-REM02K1070-IE	4	310	100	240	295	210	7
AX-REM02K1017-IE							
AX-REM03K5035-IE							
AX-REM03K5010-IE	5	306	350	140	190	50	8.1
AX-REM19K0006-IE							
AX-REM19K0008-IE							
AX-REM19K0020-IE							
AX-REM19K0030-IE							
AX-REM38K0012-IE	306	350	140	290	50	14.5	

Standard connections



*1 L is the common reference for analog input and also for analog output.

Terminal block specifications

Terminal	Name	Function (signal level)
R/L1, S/L2, T/L3	Main circuit power supply input	Used to connect line power to the drive.
U/T1, V/T2, W/T3	Inverter output	Used to connect the motor
PD/+1, P/+	External DC reactor terminal	Normally connected by the short-circuit bar. Remove the short-circuit bar between +1 and P/+2 when a DC reactor is connected.
P/+, RB	Braking resistor connection terminals	Connect option braking resistor (if a braking torque is required)
P/+, N/-	Regenerative braking unit connection terminal	Connect optional regenerative braking units.
⊕	Grounding	For grounding (grounding should conform to the local grounding code.)

Control circuit

Type	No.	Signal name	Function	Signal level
Frequency reference input	H	Frequency reference power supply	10 VDC 20 mA max	
	O	Voltage frequency reference input	0 to 12 VDC (10 kΩ)	
	O2	Voltage auxiliary frequency reference	0 to +/- 12 VDC (10 kΩ)	
	OI	Current frequency reference input	4 to 20 mA (100 Ω)	
	L	Frequency reference common	Common terminal for analog monitor (AM, AMI) terminals	
Monitor Output	AM	Multi-function analog voltage output	Factory setting: Output frequency	2 mA max
	AMI	Multi-function analog current output	Factory setting: Output frequency	4 to 20 mA (max imp 250 Ω)
	FM	PWM monitor output	Factory setting: Output frequency	0 to 10 VDC Max 3.6 kHz
Power Supply	P24	Internal 24 VDC	Power supply for contact input signal	100 mA max
	CM1	Input common	Common terminal for P24, TH and FM digital monitor	
Function Selection	FW	Forward rotation command terminal	Motor runs in forwards direction when FW is ON	
	1	Multi-function input	Factory setting: Reverse (RV)	
	2		Factory setting: External trip (EXT)	
	3		Factory setting: Reset (RS)	
	4		Factory setting: Multi-step speed reference 1 (CF1)	
	5		Factory setting: Multi-step speed reference 2 (CF2)	
	6		Factory setting: Jogging (JG)	
	7		Factory setting: Second control (SET)	
	8		Factory setting: No allocation (NO)	
PLC	Multi-function input common	Sink logic: Short-circuiting P24 and PLC Source logic: Short-circuiting PLC and CM1 With external supply remove short-circuit bar		
Status/Factor	11	Multi-function output	Factory setting: During Run (RUN)	
	12		Factory setting: 0 Hz signal (ZS)	
	13		Factory setting: Overload warning (OL)	
	14		Factory setting: Overtorque (OTQ)	
	15		Factory setting: Constant speed arrival (FA1)	
	CM2	Multi-function output common	Common terminal for multi-function output terminals 11 to 15	
Relay output	AL1	Relay output (Normally close)	Factory setting: Alarm output (AL) Under normal operation MA-MC open MB-MC close	R load AL1-AL0 250 VAC 2 A AL2-AL0 250 VAC 1 A I load 250 VAC 0.2 A
	AL2	Relay output (Normally open)		
	AL0	Relay output common		
Sensor	TH	External thermistor input terminal	SC terminal functions as the common terminal 100 mW minimum Impedance at temperature error: 3 kΩ	0 to 8 VDC
Comms	SP	RS485 Modbus terminals	-	Differential input
	SN			
	RP	RS485 terminating resistor terminals		
	SN			

Inverter heat loss

Three-phase 200 V class

Model 3G3RX-		A2004	A2007	A2015	A2022	A2037	A2055	A2075	A2110	A2150	A2185	A2220	A2300	A2370	A2450	A2550
Inverter capacity kVA	200 V	1.0	1.7	2.5	3.6	5.7	8.3	11.0	15.9	22.1	26.3	32.9	41.9	50.2	63.0	76.2
	240 V	1.2	2.0	3.1	4.3	6.8	9.9	13.3	19.1	26.6	31.5	39.4	50.2	60.2	75.6	91.4
Rated current (A)		3.0	5.0	7.5	10.5	16.5	24	32	46	64	76	95	121	145	182	220
Heat loss W	Losses at 70% load	64	76	102	127	179	242	312	435	575	698	820	1100	1345	1625	1975
	Losses at 100% load	70	88	125	160	235	325	425	600	800	975	1150	1550	1900	2300	2800
Efficiency at rated output		85.1	89.5	92.3	93.2	94.0	64.4	94.6	94.8	94.9	95.0	95.0	95.0	95.1	95.1	95.1
Cooling Method		Forced-air-cooling														

Three-phase 400 V class

Model 3G3RX-		A4004	A4007	A4015	A4022	A4040	A4055	A4075	A4110	A4150	A4185	A4220	A4300	A4370	A4450	A4550	B4750	B4900	B411K	B413K
Inverter capacity kVA	400 V	1.0	1.7	2.5	3.6	6.2	9.7	13.1	17.3	22.1	26.3	33.2	40.1	51.9	63.0	77.6	103.2	121.9	150.3	180.1
	480 V	1.2	2.0	3.1	4.3	7.4	11.6	15.8	20.7	26.6	31.5	39.9	48.2	62.3	75.6	93.1	123.8	146.3	180.4	216.1
Rated current (A)		1.5	2.5	3.8	5.3	9.0	14	19	25	32	38	48	58	75	91	112	149	176	217	260
Heat loss W	Losses at 70% load	64	76	102	127	179	242	312	435	575	698	820	1100	1345	1625	1975	2675	3375	3900	4670
	Losses at 100% load	70	88	125	160	235	325	425	600	800	975	1150	1550	1900	2300	2800	3800	4800	5550	6650
Efficiency at rated output		85.1	89.5	92.3	93.2	94.0	64.4	94.6	94.8	94.9	95.0	95.0	95.0	95.1	95.1	95.1	95.2	95.2	95.2	95.2
Cooling Method		Forced-air-cooling																		

Input AC Reactor

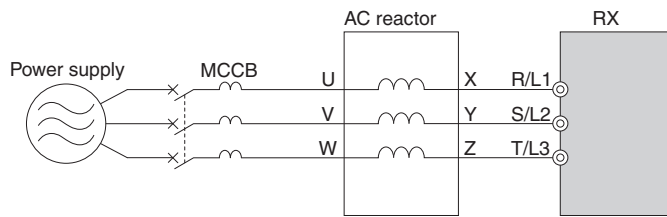

3 phase 200 V class				400 V class			
Max. applicable motor output kW	Reference	Current value A	Inductance mH	Max. applicable motor output kW	Reference	Current value A	Inductance mH
0.4 to 1.5	AX-RAI02800100-DE	10.0	2.8	0.4 to 1.5	AX-RAI07700050-DE	5.0	7.7
2.2 to 3.7	AX-RAI00880200-DE	20.0	0.88	2.2 to 3.7	AX-RAI03500100-DE	10.0	3.5
5.5 to 7.5	AX-RAI00350335-DE	33.5	0.35	5.5 to 7.5	AX-RAI01300170-DE	17.0	1.3
11.0 to 15.0	AX-RAI00180670-DE	67.0	0.18	11.0 to 15.0	AX-RAI00740335-DE	33.5	0.74
18.5 to 22.0	AX-RAI00091000-DE	100.0	0.09	18.5 to 22.0	AX-RAI00360500-DE	50.0	0.36
30.0 to 37.0	AX-RAI00071550-DE	155.0	0.07	30.0 to 37.0	AX-RAI00290780-DE	78.0	0.29
45.0 to 55.0	AX-RAI00042300-DE	230.0	0.04	45.0 to 55.0	AX-RAI00191150-DE	115.0	0.19
				75.0 to 90.0	AX-RAI00111850-DE	185.0	0.11
				110.0 to 132.0	AX-RAI00072700-DE	270.0	0.07

DC Reactor

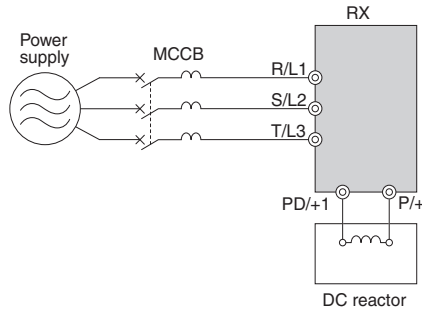

200 V class				400 V class			
Max. applicable motor output kW	Reference	Current value A	Inductance mH	Max. applicable motor output kW	Reference	Current value A	Inductance mH
0.4	AX-RC10700032-DE	3.2	10.70	0.4	AX-RC43000020-DE	2.0	43.00
0.7	AX-RC06750061-DE	6.1	6.75	0.7	AX-RC27000030-DE	3.0	27.00
1.5	AX-RC03510093-DE	9.3	3.51	1.5	AX-RC14000047-DE	4.7	14.00
2.2	AX-RC02510138-DE	13.8	2.51	2.2	AX-RC10100069-DE	6.9	10.10
3.7	AX-RC01600223-DE	22.3	1.60	4.0	AX-RC06400116-DE	11.6	6.40
5.5	AX-RC01110309-DE	30.9	1.11	5.5	AX-RC04410167-DE	16.7	4.41
7.5	AX-RC00840437-DE	43.7	0.84	7.5	AX-RC03350219-DE	21.9	3.35
11.0	AX-RC00590614-DE	61.4	0.59	11.0	AX-RC02330307-DE	30.7	2.33
15.0	AX-RC00440859-DE	85.9	0.44	15.0	AX-RC01750430-DE	43.0	1.75
18.5 to 22	AX-RC00301275-DE	127.5	0.30	18.5 to 22	AX-RC01200644-DE	64.4	1.20
30	AX-RC00231662-DE	166.2	0.23	30	AX-RC00920797-DE	79.7	0.92
37	AX-RC00192015-DE	201.5	0.19	37	AX-RC00741042-DE	104.2	0.74
45	AX-RC00162500-DE	250.0	0.16	45	AX-RC00611236-DE	123.6	0.61
55	AX-RC00133057-DE	305.7	0.13	55	AX-RC00501529-DE	152.9	0.50
				75	AX-RC00372094-DE	209.4	0.37
				90	AX-RC00312446-DE	244.6	0.31
				110	AX-RC00252981-DE	298.1	0.25
				132	AX-RC00213613-DE	361.3	0.21

Output AC Reactor

200 V class				400 V class			
Max. applicable motor output kW	Reference	Current value A	Inductance mH	Max. applicable motor output kW	Reference	Current value A	Inductance mH
0.4	AX-RAO11500026-DE	2.6	11.50	0.4 to 1.5	AX-RAO16300038-DE	3.8	16.30
0.75	AX-RAO07600042-DE	4.2	7.60				
1.5	AX-RAO04100075-DE	7.5	4.10				
2.2	AX-RAO03000105-DE	10.5	3.00				
3.7	AX-RAO01830160-DE	16.0	1.83	2.2	AX-RAO11800053-DE	5.3	11.80
5.5	AX-RAO01150220-DE	22.0	1.15	4.0	AX-RAO07300080-DE	8.0	7.30
7.5	AX-RAO00950320-DE	32.0	0.95	5.5	AX-RAO04600110-DE	11.0	4.60
11	AX-RAO00630430-DE	43.0	0.63	7.5	AX-RAO03600160-DE	16.0	3.60
15	AX-RAO00490640-DE	64.0	0.49	11	AX-RAO02500220-DE	22.0	2.50
18.5	AX-RAO00390800-DE	80.0	0.39	15	AX-RAO02000320-DE	32.0	2.00
22	AX-RAO00330950-DE	95.0	0.33	18.5	AX-RAO01650400-DE	40.0	1.65
30	AX-RAO00251210-DE	121.0	0.25	22	AX-RAO01300480-DE	48.0	1.30
37	AX-RAO00191450-DE	145.0	0.19	30	AX-RAO01030580-DE	58.0	1.03
45	AX-RAO00161820-DE	182.0	0.16	37	AX-RAO00800750-DE	75.0	0.80
55	AX-RAO00132200-DE	220.0	0.13	45	AX-RAO00680900-DE	90.0	0.68
				55	AX-RAO00531100-DE	110.0	0.53
				75	AX-RAO00401490-DE	149.0	0.40
				90	AX-RAO00331760-DE	176.0	0.33
				110	AX-RAO00262170-DE	217.0	0.26
				132	AX-RAO00212600-DE	260.0	0.21

Braking Unit

Voltage	Reference	Specifications				Minimum connectable resistor (Ohms)
		Permanent		Peak (5s max)		
		Current (A)	Brake power (kVA)	Current (A)	Brake power (kVA)	
200 V	AX-BCR2035090-TE	35	13	90	32	4
	AX-BCR2070130-TE	70	25	130	47	2.8
400 V	AX-BCR4015045-TE	15	11	45	33	16
	AX-BCR4017068-TE	17	13	68	51	11
	AX-BCR4035090-TE	35	26	90	67	8.5
	AX-BCR4070130-TE	70	52	130	97	5.5
	AX-BCR4090240-TE	90	67	240	180	3.2

Ordering information

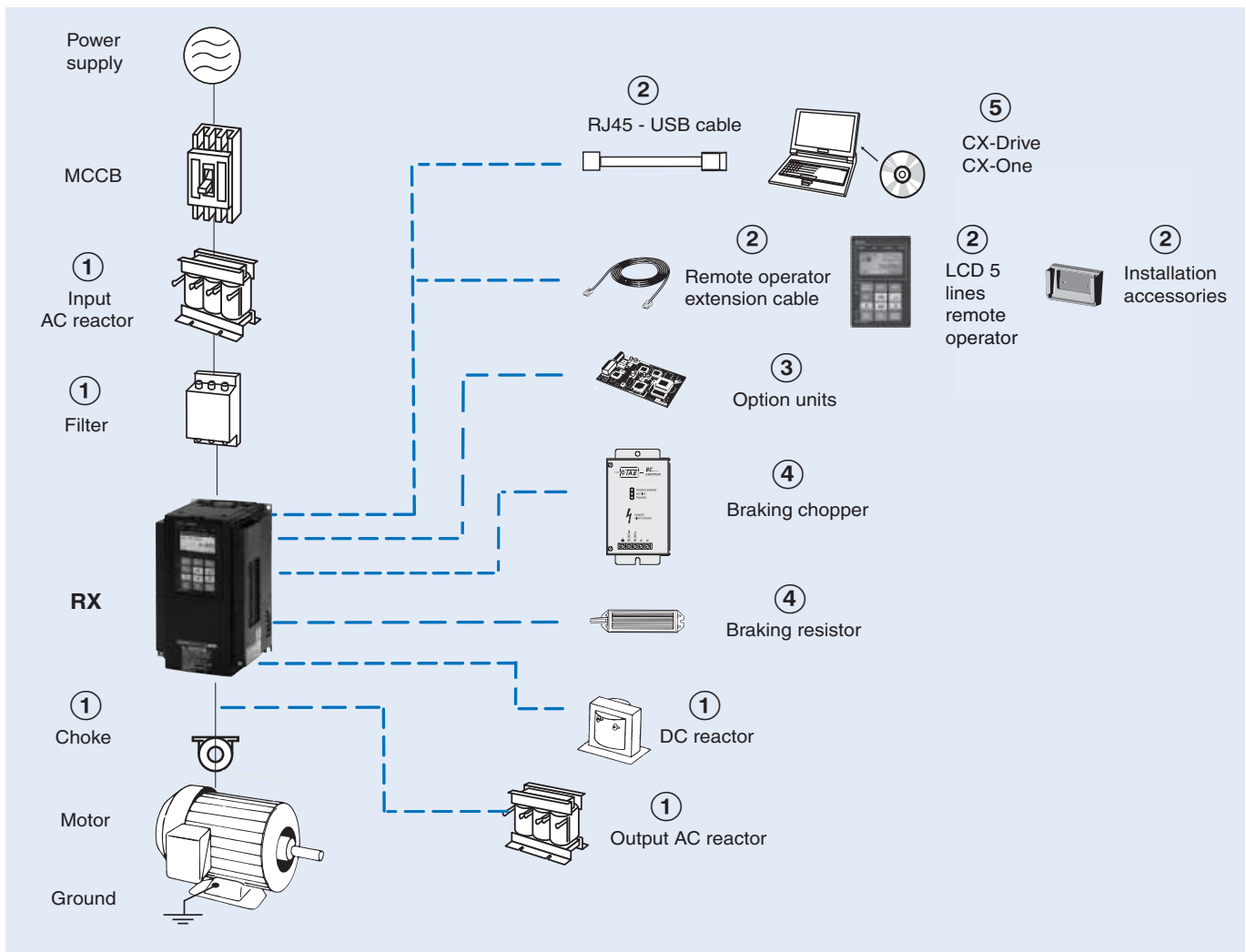

3G3RX

Specifications					Model	Specifications					Model
Voltage class	Constant torque		Variable torque		Standard	Voltage class	Constant torque		Variable torque		Standard
	Max motor kW	Rated current A	Max motor KW	Rated current A			Max motor kW	Rated current A	Max motor KW	Rated current A	
Three-phase 200 V	0.4	3.0	0.75	3.7	3G3RX-A2004-EF1	Three-phase 400 V	0.4	1.5	0.75	1.9	3G3RX-A4004-EF1
	0.75	5.0	1.5	6.3	3G3RX-A2007-EF1		0.75	2.5	1.5	3.1	3G3RX-A4007-EF1
	1.5	7.5	2.2	9.4	3G3RX-A2015-EF1		1.5	3.8	2.2	4.8	3G3RX-A4015-EF1
	2.2	10.5	4.0	12	3G3RX-A2022-EF1		2.2	5.3	4.0	6.7	3G3RX-A4022-EF1
	4.0	16.5	5.5	19.6	3G3RX-A2037-EF1		4.0	9.0	5.5	11.1	3G3RX-A4040-EF1
	5.5	24	7.5	30	3G3RX-A2055-EF1		5.5	14	7.5	16	3G3RX-A4055-EF1
	7.5	32	11	44	3G3RX-A2075-EF1		7.5	19	11	22	3G3RX-A4075-EF1
	11	46	15	58	3G3RX-A2110-EF1		11	25	15	29	3G3RX-A4110-EF1
	15	64	18.5	73	3G3RX-A2150-EF1		15	32	18.5	37	3G3RX-A4150-EF1
	18.5	76	22	85	3G3RX-A2185-EF1		18.5	38	22	43	3G3RX-A4185-EF1
	22	95	30	113	3G3RX-A2220-EF1		22	48	30	57	3G3RX-A4220-EF1
	30	121	37	140	3G3RX-A2300-EF1		30	58	37	70	3G3RX-A4300-EF1
	37	145	45	169	3G3RX-A2370-EF1		37	75	45	85	3G3RX-A4370-EF1
	45	182	55	210	3G3RX-A2450-EF1		45	91	55	105	3G3RX-A4450-EF1
55	220	75	270	3G3RX-A2550-EF1	55	112	75	135	3G3RX-A4550-EF1		
					75	149	90	160	3G3RX-B4750-EF1		
					90	176	110	195	3G3RX-B4900-EF1		
					110	217	132	230	3G3RX-B411K-EF1		
					132	260	160	290	3G3RX-B413K-EF1		

① Line filters

Rasmi Line filter									
200V					400V				
Model 3G3RX-□	Reference	Rated current (A)	Leakage Nom / Max	kg	Model 3G3RX-□	Reference	Rated current (A)	Leakage Nom / Max	kg
A2004 / A2007/ A2015/ A2022 / A2037	AX-FIR2018-RE	18	0.7/40 mA	2.0	A4004/ A4007/ A4015/ A4022/ A4040	AX-FIR3010-RE	10	0.3/40 mA	1.9
A2055 / A2075 / A2110	AX-FIR2053-RE	53	0.7/40 mA	2.5	A4055 / A4075 / A4110	AX-FIR3030-RE	30	0.3/40 mA	2.2
A2150/ A2185/ A2220	AX-FIR2110-RE	110	1.2/70 mA	8.0	A4150/ A4185/ A4220	AX-FIR3053-RE	53	0.8/70 mA	4.5
A2300	AX-FIR2145-RE	145	1.2/70 mA	8.6	A4300	AX-FIR3064-RE	64	3/160 mA	7.0
A2370/ A2450	AX-FIR3250-RE	250	6/300 mA	13.0	A4370	AX-FIR3100-RE	100	2/130 mA	8.0
A2550	AX-FIR3320-RE	320	6/300 mA	13.2	A4450 / A4550	AX-FIR3130-RE	130	2/130 mA	8.6
					A4750 / A4900	AX-FIR3250-RE	250	10/500 mA	13.0
					A411K / A413K	AX-FIR3320-RE	320	10/500 mA	13.2

① Input AC Reactors

Voltage			
3-phase 200 VAC		3-phase 400 VAC	
Inverter Model 3G3RX-□	AC Reactor Reference	Inverter Model 3G3RX-□	AC Reactor Reference
A2004 / A2007 / A2015	AX-RAI02800100-DE	A4004 / A4007 / A4015	AX-RAI07700050-DE
A2022 / A2037	AX-RAI00880200-DE	A4022 / A4040	AX-RAI03500100-DE
A2055 / A2075	AX-RAI00350335-DE	A4055 / A4075	AX-RAI01300170-DE
A2110 / A2150	AX-RAI00180670-DE	A4110 / A4150	AX-RAI00740335-DE
A2185 / A2220	AX-RAI00091000-DE	A4185 / A4220	AX-RAI00360500-DE
A2300 / A2370	AX-RAI00071550-DE	A4300 / A4370	AX-RAI00290780-DE
A2450 / A2550	AX-RAI00042300-DE	A4450 / A4550	AX-RAI00191150-DE
		A4750 / A4900	AX-RAI00111850-DE
		A411K / A413K	AX-RAI00072700-DE

① DC Reactors

Voltage			
3-phase 200 VAC		3-phase 400 VAC	
Inverter Model 3G3RX-□	AC Reactor Reference	Inverter Model 3G3RX-□	AC Reactor Reference
A2004	AX-RC10700032-DE	A4004	AX-RC43000020-DE
A2007	AX-RC06750061-DE	A4007	AX-RC27000030-DE
A2015	AX-RC03510093-DE	A4015	AX-RC14000047-DE
A2022	AX-RC02510138-DE	A4022	AX-RC10100069-DE
A2037	AX-RC01600223-DE	A4040	AX-RC06400116-DE
A2055	AX-RC01110309-DE	A4055	AX-RC04410167-DE
A2075	AX-RC00840437-DE	A4075	AX-RC03350219-DE
A2110	AX-RC00590614-DE	A4110	AX-RC02330307-DE
A2150	AX-RC00440859-DE	A4150	AX-RC01750430-DE
A2185 / A2220	AX-RC00301275-DE	A4185 / A4220	AX-RC01200644-DE
A2300	AX-RC00231662-DE	A4300	AX-RC00920797-DE
A2370	AX-RC00192015-DE	A4370	AX-RC00741042-DE
A2450	AX-RC00162500-DE	A4450	AX-RC00611236-DE
A2550	AX-RC00133057-DE	A4550	AX-RC00501529-DE
		A4750	AX-RC00372094-DE
		A4900	AX-RC00312446-DE
		A411K	AX-RC00252981-DE
		A413K	AX-RC00213613-DE

① Chokes

Model	Diameter	Description
AX-FER2102-RE	21	For 2.2 kW motors or below
AX-FER2515-RE	25	For 15 kW motors or below
AX-FER5045-RE	50	For 45 kW motors or below
AX-FER6055-RE	60	For 55 kW motors or above

① Output AC Reactor

Voltage			
200V		400V	
Model 3G3RX-□	Reference	Model 3G3RX-□	Reference
A2004	AX-RAO11500026-DE	A4004 / A4007 / A4015	AX-RAO16300038-DE
A2007	AX-RAO07600042-DE		
A2015	AX-RAO04100075-DE		
A2022	AX-RAO03000105-DE	A4022	AX-RAO11800053-DE
A2037	AX-RAO01830160-DE	A4040	AX-RAO07300080-DE
A2055	AX-RAO01150220-DE	A4055	AX-RAO04600110-DE

Voltage			
200V		400V	
A2075	AX-RAO00950320-DE	A4075	AX-RAO03600160-DE
A2110	AX-RAO00630430-DE	A4110	AX-RAO02500220-DE
A2150	AX-RAO00490640-DE	A4150	AX-RAO02000320-DE
A2185	AX-RAO00390800-DE	A4185	AX-RAO01650400-DE
A2220	AX-RAO00330950-DE	A4220	AX-RAO01300480-DE
A2300	AX-RAO00251210-DE	A4300	AX-RAO01030580-DE
A2370	AX-RAO00191450-DE	A4370	AX-RAO00800750-DE
A2450	AX-RAO00161820-DE	A4450	AX-RAO00680900-DE
A2550	AX-RAO00132200-DE	A4550	AX-RAO00531100-DE
		A4750	AX-RAO00401490-DE
		A4900	AX-RAO00331760-DE
		A411K	AX-RAO00262170-DE
		A413K	AX-RAO00212600-DE

② Accessories

Types	Model	Description	Functions
Digital operator	AX-OP05-E	LCD remote operator	5 Line LCD remote operator with copy function, cable length max. 3m. ^{*1}
	3G3AX-CAJOP300-EE	Remote operator cable	3 meters cable for connecting remote operator
	3G3AX-OP01	LED remote operator	LED remote operator, cable length max. 3m
	4X-KITMINI	Mounting kit for LED operator	Mounting kit for LED operator on panel
	3G3AX-OP05-H-E	Operator holder	Holder to put the AX-OP05-E inside the cabinet
	3G3AX-OP05-B-E	Blind cover	Blind cover to be used in combination with communication option boards
Accessories	USB-Convertercable	USB converter / USB cable	RJ45 to USB connection cable
	3G3AX-PCACN2		

*1 please note, models with firmware 4287 and 4288, the operator will only display 2 lines of text.

③ Option boards

Types	Model	Description	Functions
Encoder Feedback	3G3AX-PG	PG speed controller option card	Phase A,B and Z pulse (differential pulse) inputs (RS-422) Pulse train position command input (RS-422) Pulse monitor output (RS-422) PG frequency range: 100 kHz max
Communication option board	3G3AX-RX-DRT	DeviceNet option card	Used for running or stopping the inverter, setting or referencing parameters, and monitoring output frequency, output current... through communications with the host controller.
	3G3AX-RX-PRT	Profibus option card	
	3G3AX-RX-ECT	Ethercat option card	
	3G3AX-RX-CRT	CompoNet option card	
	3G3AX-RX-MRT	Mechatrolink-II option card	

④ Braking unit, braking resistor unit

Voltage	Inverter				Braking resistor unit					
	Max. motor kW	Inverter 3G3RX□ 3-phase	Braking Unit AX-BCR□	Connectable min. resistance Ω	Inverter mounted type (3 %ED, 10 sec max)		Braking torque %	External resistor 10%ED 10 sec max for built-in 5 sec max for Braking Unit		Braking torque %
					Type AX-	Resist Ω		Type AX-	Resist Ω	
200 V (single-/three-phase)	0.55	2004	Built-in	50	REM00K1200-IE	200	180	REM00K1200-IE	200	180
	1.1	2007					100	REM00K2070-IE	70	200
	1.5	2015					35	140	REM00K4075-IE	75
	2.2	2022		90	REM00K4035-IE	35		180		
	4.0	2037		50	REM00K6035-IE	35		100		
	5.5	2055		16	10	75	REM00K9020-IE	20	150	
	7.5	2075				55	REM01K9017-IE	17	110	
	11.0	2110				40	REM02K1017-IE	17	75	
	15.0	2150		7.5	5	55	REM03K5010-IE	10	95	
	18.5	2185				75	REM19K0008-IE	8	95	
	22.0	2220				65			80	
	30.0	2300		2035090-TE	4			6	80	
	37.0	2370				6	60			
	45.0	2450		2070130-TE	2.8			3	105	
	55.0	2550				2 x REM19K0006-IE	3	85		

Inverter					Braking resistor unit							
Voltage	Max. motor kW	Inverter 3G3RX□ 3-phase	Braking Unit AX-BCR□	Connectable min. resistance Ω	Inverter mounted type (3 %ED, 10 sec max)		Braking torque %	External resistor 10%ED 10 sec max for built-in 5 sec max for Braking Unit		Braking torque %		
					Type AX-	Resist Ω		Type AX-	Resist Ω			
400 V (three-phase)	0.55	4004	Built-in	100	REM00K1400-IE	400	200	REM00K1400-IE	400	200		
	1.1	4007			200	REM00K1200-IE	200	190	REM00K2200-IE	200	190	
	1.5	4015			200	REM00K2200-IE	200	130	REM00K5120-IE	120	200	
	2.2	4022			120	REM00K2120-IE	120	120	REM00K6100-IE	100	140	
	4.0	4040		70	REM00K4075-IE	75	140	REM00K9070-IE	70	150		
	5.5	4055			35	REM00K6100-IE	100	100	REM01K9070-IE	70	110	
	7.5	4075				REM00K6100-IE	100	50	REM02K1070-IE	70	75	
	11.0	4110		24	REM00K9070-IE	70	55	REM03K5035-IE	35	110		
	15.0	4150			20	REM03K5035-IE	35	90	REM19K0030-IE	30	100	
	18.5	4185				75	REM19K0030-IE	30	85			
	22.0	4220		4015045-TE	16					REM19K0020-IE	20	95
	30.0	4300		4017068-TE	11					REM38K0012-IE	15	125
	37.0	4370								REM38K0012-IE	15	100
	45.0	4450		4035090-TE	8.5					2 x REM19K0020-IE	10	100
	55.0	4550								3 x REM19K0030-IE	10	75
	75.0	4750		4070130-TE	5.5					2 x REM38K0012-IE	6	105
	90.0	4900								3 x REM38K0012-IE	4	125
110.0	411K	4090240-TE	3.2					3 x REM38K0012-IE	4	105		
132.0	413K							3 x REM38K0012-IE	4	105		

⑤ Computer software

Types	Model	Description	Installation
Software	CX-drive	Computer software	Configuration and monitoring software tool
	CX-One	Computer software	Configuration and monitoring software tool
	€Saver	Computer software	Software tool for Energy Saving calculation

ALL DIMENSIONS SHOWN ARE IN MILLIMETERS.

To convert millimeters into inches, multiply by 0.03937. To convert grams into ounces, multiply by 0.03527.

LX

Born to drive lifts

- Current vector control with or without PG
- High strating torque (200%/0.3Hz Sensorless vector, 200%/0Hz close loop vector control)
- IM&PM motor control
- Rescue function with flexible power supply (Control 220VAC, Power from 48VDC or 36VAC)
- Static & Rotary advanced auto tuning
- Safety embedded: IEC 615087 SIL2
- Clock and calendar function
- Silent operation by Fan switch off by temperature
- One parameter Dynamic tuning
- Lift language (Hz, m/s, rpm...)
- Built-in logic programmability
- Universal dual encoder option (Endat,Hiperface,Line driver)
- Positioning functionality with 40 floor memory&autolearning
- Dedicated lift functionality (Brake control, Lift sequence...)
- CE, cULus, RoHS

Ratings

- 200 V Class three-phase 4.0 to 37 kW
- 400 V Class three-phase 3.7 to 37 kW



System configuration

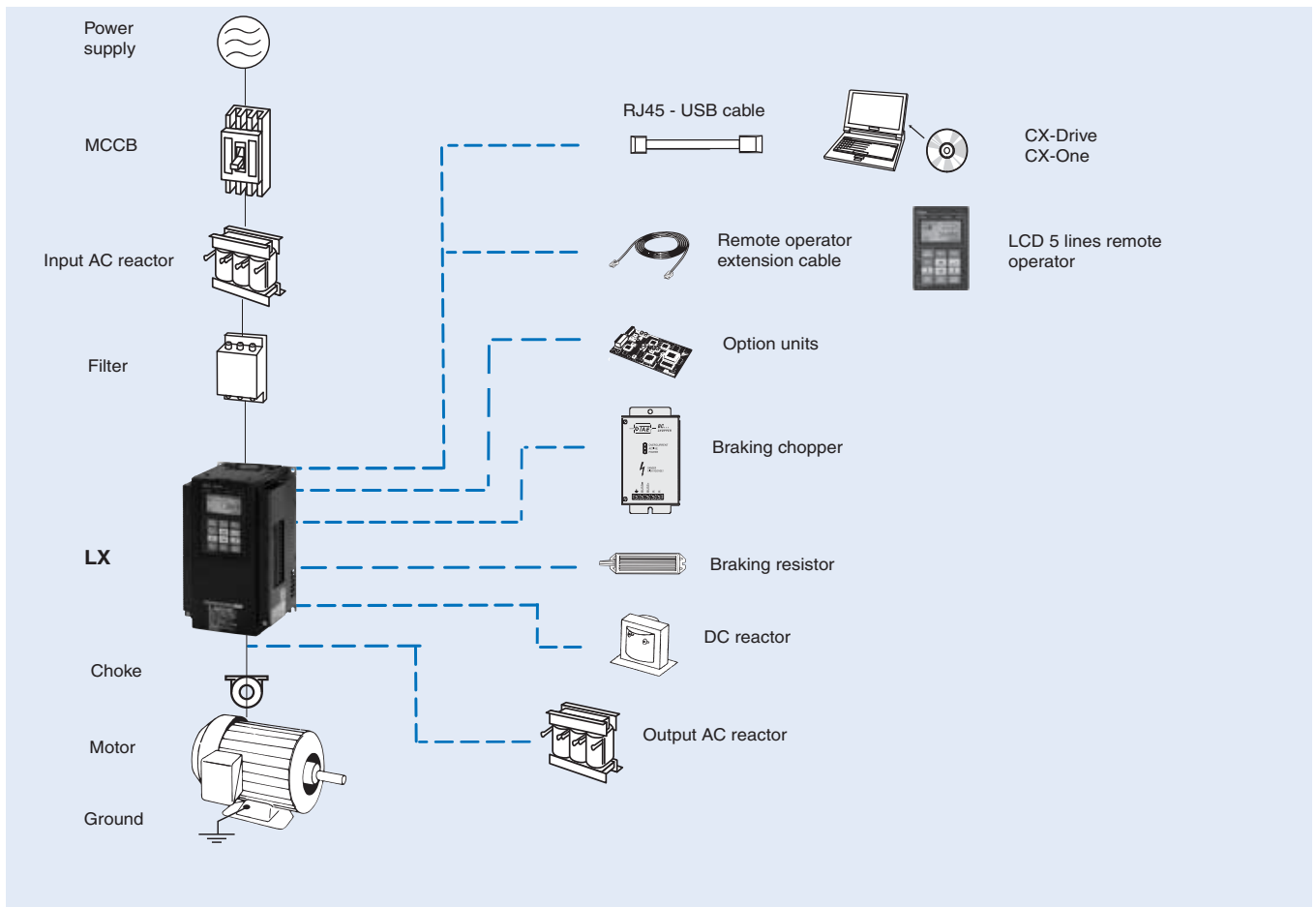

Specifications

Type designation

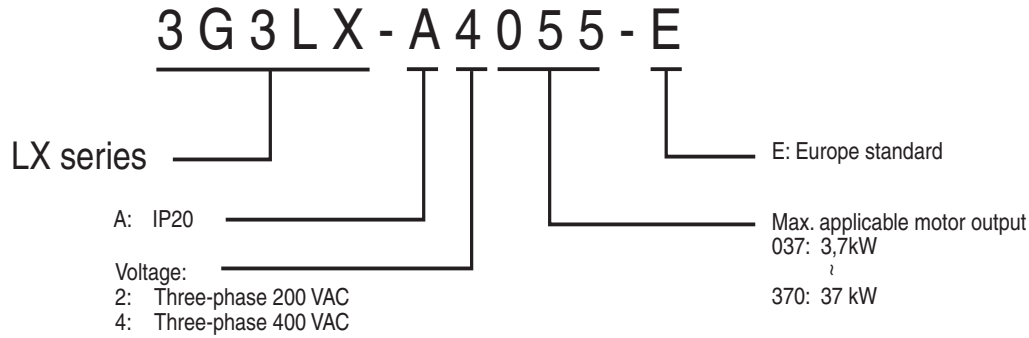

200 V class

Three-phase: 3G3LX-□		A2040	A2055	A2075	A2110	A2150	A2185	A220	A2300	A2370	
Motor kW ¹		4.0	5.5	7.5	11.0	15.0	18.5	22.0	30.0	37.0	
Output characteristics	Inverter capacity kVA	200 V	5.7	8.3	11.0	15.9	22.1	26.3	32.9	41.9	50.2
		240 V	6.8	9.9	13.3	19.1	26.6	31.5	39.4	50.2	60.2
Rated output current (A) (3min, 50%ED)		17.5	25	33	49	64	80	96	130	160	
Max. output voltage		Proportional to input voltage: 0..240 V									
Max. output frequency		400 Hz									
Power supply	Rated input voltage and frequency		Control supply: 1-phase 200..240 V 50/60 Hz								
			Power supply: 3-phase 200..240 V 50/60 Hz								
	Allowable voltage fluctuation		-15%..+10%								
	Allowable frequency fluctuation		5%								
Braking	Regenerative braking		Internal BRD circuit (external discharge resistor)							External unit	
	Minimum connectable resistance (Ohms)		24	16	10	10	7.5	7.5	5	-	
	Duty at minimum resistance		10%								
Minimum resistance at continuous running (Ohms)		100	50	50	50	35	35	35			
Protective structure		IP20									
Cooling method		Forced air cooling									

¹ Based on a standard IM 3-Phase standard motor.

400V class

Three-phase: 3G3LX-□		A4037	A4040	A4055	A4075	A4110	A4150	A4185	A4220	A4300	A4370	
Motor kW ¹		3.7	4.0	5.5	7.5	11.0	15.0	18.5	22.0	30.0	37.0	
Output characteristics	Inverter capacity kVA	400 V	5.7	5.9	9.7	13.1	17.3	22.1	26.3	33.2	40.1	51.9
		480 V	6.8	7.1	11.6	15.8	20.7	26.6	31.5	39.9	48.2	62.3
Rated output current (A) (3min, 50%ED)		9	11	14	19	27	34	41	48	65	80	
Max. output voltage		Proportional to input voltage: 0..480 V										
Max. output frequency		400 Hz										
Power supply	Rated input voltage and frequency		Control supply: 1-phase 200..240 V 50/60 Hz									
			Power supply: 3-phase 380..480 V 50/60 Hz									
	Allowable voltage fluctuation		-15%..+10%									
	Allowable frequency fluctuation		5%									
Braking	Regenerative braking		Internal BRD circuit (external discharge resistor)							External unit		
	Minimum connectable resistance (Ohms)		70	70	70	35	35	24	24	20	-	
	Duty at minimum resistance		10%									
Minimum resistance at continuous running (Ohms)		200	200	200	150	150	100	100	100			
Protective structure		IP20										
Cooling method		Forced air cooling										

¹ Based on a standard IM 3-Phase standard motor.

Common specifications

Model number LX□		Specifications	
Control functions	Control methods	Phase-to-phase sinusoidal pulse with modulation PWM (V/f control for IM, Open loop vector control for IM, Closed loop vector control for IM, Closed loop vector control for PM)	
	Output frequency range	0.00 to 400.00 Hz	
	Frequency precision	Digital set value: ±0.01% of the max. frequency Analogue set value: ±0.2% of the max. frequency (25 ±10 °C)	
	Resolution of frequency set value	Digital set value: 0.01 Hz Analog input: 12 bit	
	Resolution of output frequency	0.01Hz	
	Starting torque	200% at 0.3Hz (Open loop vector control) 150% at 0Hz (Closed loop vector control)	
	Overload capability	150% for 30 sec	
	External frequency set value	0 to 10 VDC (10 KΩ), -10 to 10 VDC (10 KΩ), 4 to 20 mA (100 Ω), RS485 Modbus	
	Multi input frequency set values	7 multi speeds 10 speeds: Fast, Crawl, Intermediate 1/2/3, Releveling, inspection 1/2, Rescue 1/2	
Functionality	Inputs signals	9 terminals (7 multi-function plus GS1 and GS2, NO/NC switchable, sink/source logic switchable) [Terminal function] SET (set 2nd motor data), FRS (Free-run stop), EXT (External trip), SFT (Software lock), RS (Reset), PCLR (Clear the current position), MI1 (General-purpose input 1), MI2 (General-purpose input 2), MI3 (General-purpose input 3), MI4 (General-purpose input 4), MI5 (General-purpose input 5), MI6 (General-purpose input 6), MI7 (General-purpose input 7), MI8 (General-purpose input 8), SPD1 (Multi-speed 1 setting), SPD2 (Multi-speed 2 setting), SPD3 (Multi-speed 3 setting), RESC (Rescue), INSP (Inspection), RL (Releveling), COK (Contactor check signal), BOK (Brake check signal), FP1 (Floor position 1), FP2 (Floor position 2), FP3 (Floor position 3), FP4 (Floor position 4), FP5 (Floor position 5), PAL (Auto learning data latch trigger), TCL (Torque bias latch trigger), LVS (Leveling signal), NFS (Near floor), CMC (control mode change), No allocation (no)	
	Output signals	4 Relay output terminals: NO/NC switchable [Terminal function] RUN (Running), FA1 (Constant-speed reached), FA2 (Set frequency overreached), OL (Overload advance signal (1), AL (Alarm signal), FA3 (Set frequency reached), OTQ (Over-torque), IP (Instantaneous power failure), UV (Under voltage), TRQ (Torque limited), RNT (Operation time over), ONT (Plug-in time over), THM (Thermal alarm signal), ZS (0Hz detection signal), DSE (Speed deviation maximum), POK (Positioning completed), FA4 (Set frequency overreached 2), FA5 (Set frequency reached 2), OL2 (Overload advance signal 2), WAC (Capacitor life warning), WAF (Cooling-fan speed drop), FR (starting contact signal), OHF (Heat sink overheat warning), LOC (Low-current indication signal), MO1 (General-purpose output 1), MO2 (General-purpose output 2), MO3 (General-purpose output 3), MO4 (General-purpose output 4), MO5 (General-purpose output 5), MO6 (General-purpose output 6), IRDY (Inverter ready), FWR (Forward rotation), RVR (Reverse rotation), MJA (Major failure), CON (Contactor control signal), BRK (Brake control signal), UPS (Light load search status), UPD (Light load search direction), GMON (Gate suppress monitor), MPS (Magnet pole position search)	
	Function for Lift	Dedicated lift sequence built-in (Speed control, Direct position control), Direct control motor brake and contactor, Quick floor function, Torque bias at start (at closed loop vector control), ASR gain adjustment, Lift units (speed, position, Accel/Decel), Motor constant saved on inverter and encoder (Hiperface, EnDat), Emergency operation by UPS or battery (Control supply 1 phase 220V, Power supply 48 to 600 VDC or 1 phase 220V)	
	Analogue inputs	Two analogue inputs 0 to 10 V and -10 to 10 V (10 KΩ), one 4 to 20 mA (100 Ω) (12 bits resolution)	
	Analogue outputs	Analog voltage output (0 to 10Vdc 10 bits resolution), Analog current output (0 to 20mA 10 bits resolution, Pulse train output (Max frequency 3.6KHz, max current 1.2mA)	
	Accel/Decel times	0.01 to 3600.0 s (linear/ S-curve for lift, multi stage Acceleration/Deceleration)	
	Display	Status indicator LED's Run, Program, Power, Alarm, Hz, Amps, Volts, % Digital operator: Available to monitors: Output speed, Output current, Output torque, Output voltage, Input power, Electronic thermal overload, LAD speed, Motor temperature, Heat sink temperature, Output torque (signed value), General-purpose output YA(n)	
	Protection functions	Motor overload protection	Electronic Thermal overload relay and PTC thermistor input
		Instantaneous overcurrent	200% of rated current for 3 seconds
Overload		150% for 30 seconds	
Overvoltage		800 V for 400 V type and 400 V for 200 V type	
Cooling fin overheat		Temperature monitor and error detection	
Stall prevention level		Stall prevention during acceleration and constant speed	
Ground fault		Detection at power on	
Lift specific protection		Speed-reference error, Contactor error, Brake error, Wrong rotation detection, Over acceleration, Over speed, Speed deviation error	
Ambient conditions	Degree of protection	IP20	
	Ambient humidity	90% RH or less (without condensation)	
	Storage temperature	-20°C..+65°C (short-term temperature during transportation)	
	Ambient temperature	-10°C to 40°C	
	Installation	Indoor (no corrosive gas, dust, etc.)	
	Installation height	Max. 1000 m	
Vibration	Up to 22KW 5.9 m/s ² (0.6G), 10 to 55 Hz 30KW and above 2.94 m/s ² (0.3G), 10 to 55 Hz		

Dimensions

Figure 1

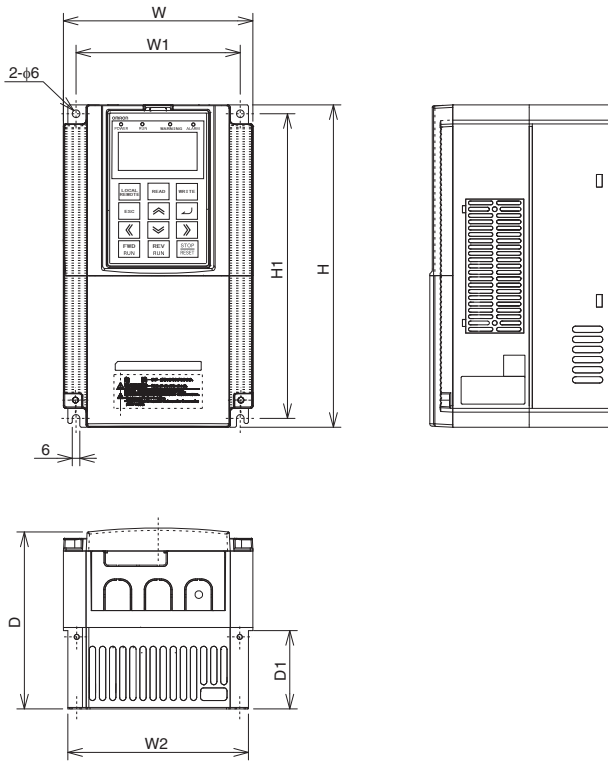

Figure 2

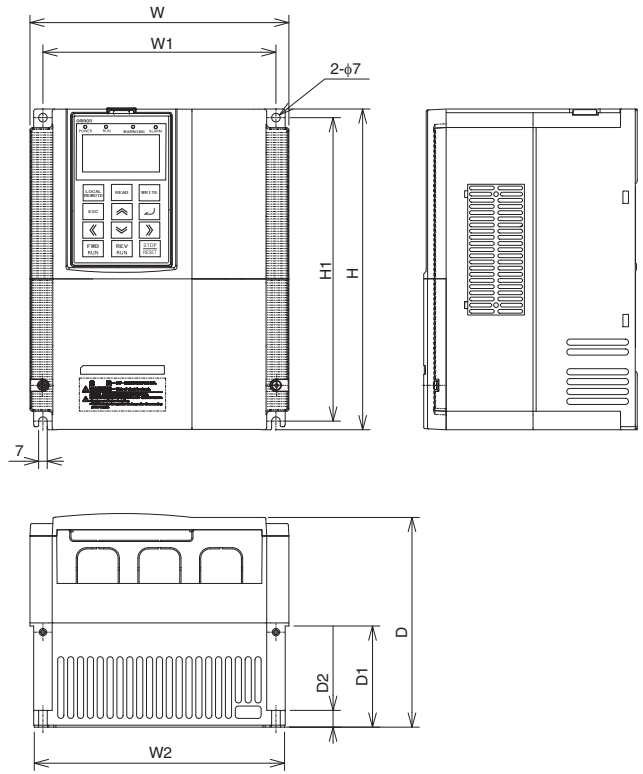

Figure 3

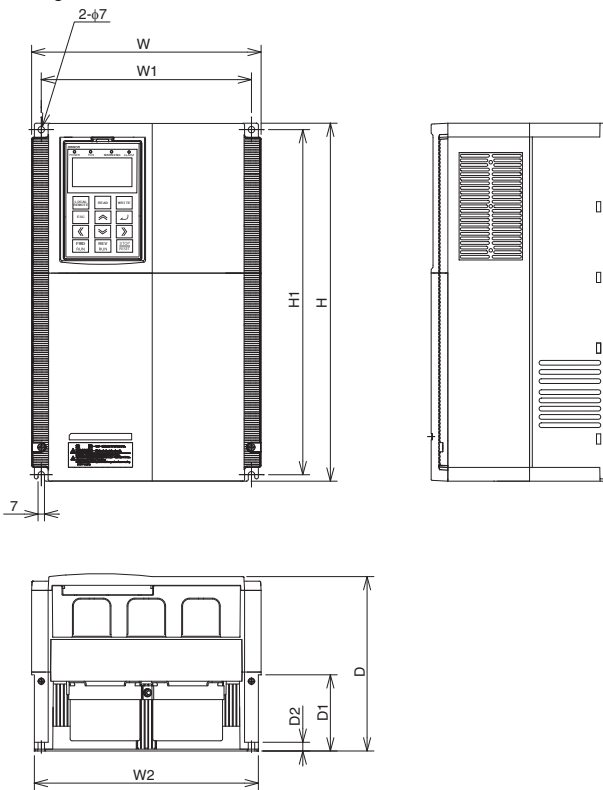
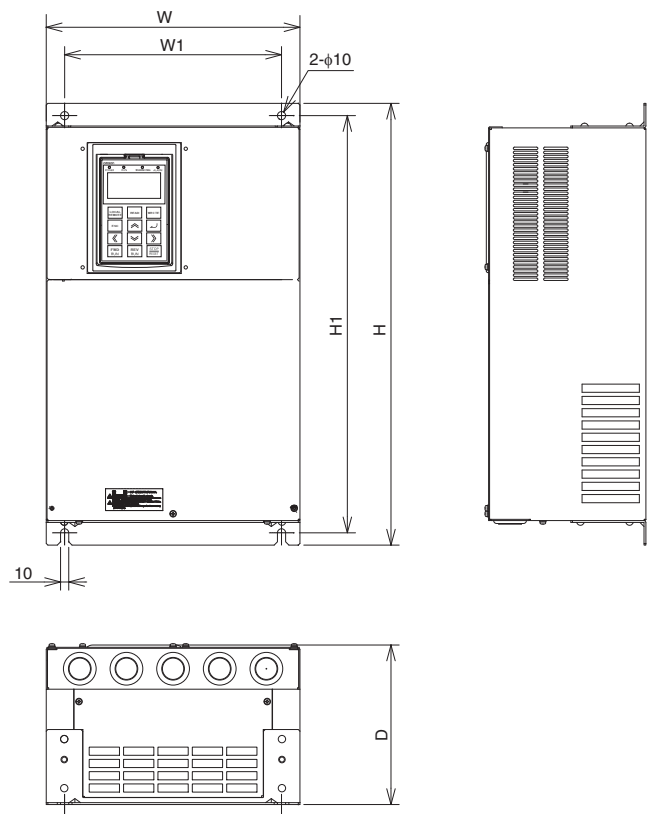

Figure 4



Voltage class	Inverter model LX□	Figure	Dimensions in mm								Weight (KG)
			W	W1	W2	H	H1	D	D1	D2	
Three-phase 200 V	A2040	1	150	130	143	255	241	140	62	-	3.5
	A2055	2	210	189	203	260	246	170	82	13.6	6
	A2075										
	A2110										
	A2150	3	250	229	244	390	376	190	83	9.5	14
	A2185										
	A2220										
A2300	4	310	265	-	540	510	195	-	-	20	
A2370		390	300	-	550	520	250	-	-	30	
Three-phase 400 V	A4037	1	150	130	143	255	241	140	62	-	3.5
	A4040	2	210	189	203	260	246	170	82	13.6	6
	A4055										
	A4075										
	A4110	3	250	229	244	390	376	190	83	9.5	14
	A4150										
	A4185										
	A4220	4	310	265	-	540	510	195	-	-	22
	A4300		390	300	-	550	520	250	-	-	30
A4370											

Schaffner filters

V	Inverter 3G3LX	Filter model	Fig	Dimensions (mm)						Weight KG	
				L	W	H	X	Y	A		B
3x200 V	A2040	Under development									
	A2055										
	A2075										
	A2110										
	A2150										
	A2185										
	A2220										
	A2300										
A2370											
3x400 V	A4037	AX-FIL3010-SE	1	300	145	40	286	110	6.5	M5	1.0
	A4040	AX-FIL3015-SE		300	207	50	286	150	6.5	M6	1.5
	A4055										
	A4075	AX-FIL3030-SE		300	207	50	286	150	6.5	M6	2.1
	A4110										
	A4150	AX-FIL3053-SE		442	250	60	426	180	6.5	M6	4.1
	A4185										
	A4220										
A4300	AX-FIL3089-SE ^{*1}	2	430	80	150	412.5	60	-	-	4.7	
A4370											

*1 Book style installation

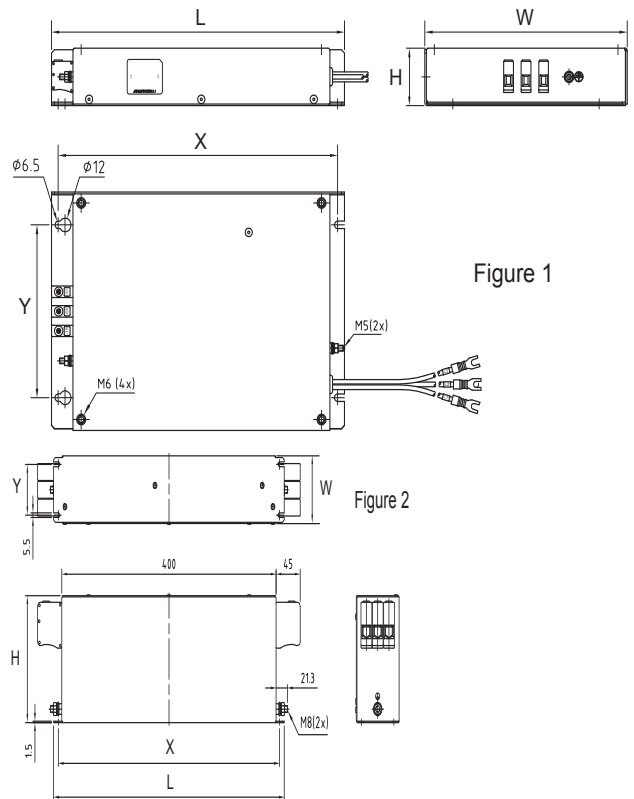

Input AC Reactor

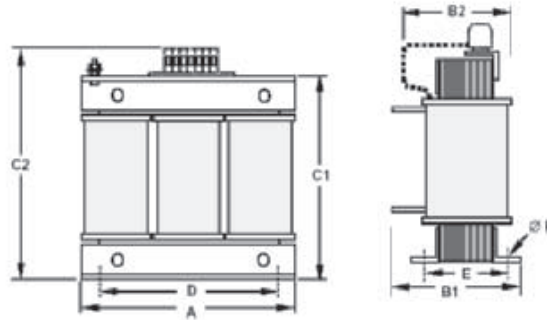

Voltage	Reference	Dimensions								Weight Kg
		A	B1	B2	C1	C2	D	E	F	
200 V	AX-RAI00880200-DE	120	-	80	-	120	140	62	6	2.35
	AX-RAI00350335-DE	180		85		190		55		5.5
	AX-RAI00180670-DE			205		85		6.5		
	AX-RAI00091000-DE			205		11.7				
AX-RAI00071550-DE	105									
400 V	AX-RAI03500100-DE	120	-	80	-	120	140	62	6	2.35
	AX-RAI01300170-DE	180		85		190		55		2.5
	AX-RAI00740335-DE			205		85		5.5		
	AX-RAI00360500-DE			105						6.5
	AX-RAI00290780-DE									11.7

DC Reactor

Figure 1

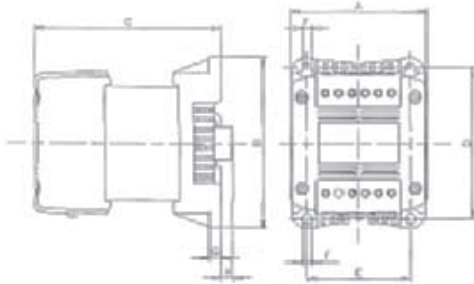
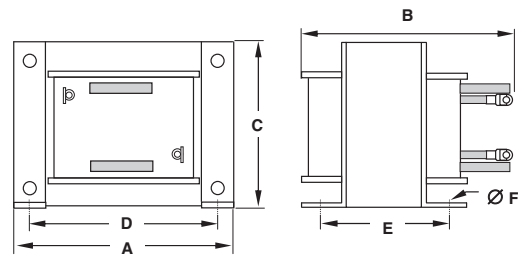
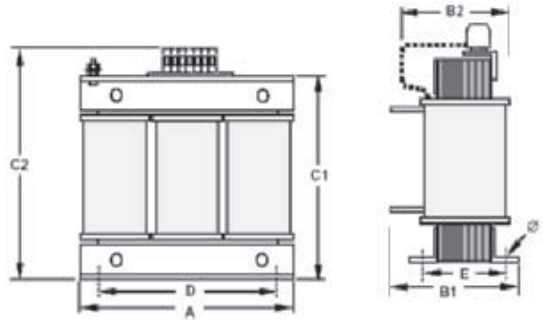

Figure 2



		200 V									400 V										
Reference AX-RC	Fig	Dimensions								kg	Reference AX-RC	Fig	Dimensions								kg
		A	B	C	D	E	F	G	H				A	B	C	D	E	F	G	H	
01600223-DE	1	108	135	124	120	82	6.5	9.5	-	3.20	06400116-DE	1	108	135	133	120	82	6.5	9.5	-	3.70
01110309-DE		120	152	136	135	94	7			5.20	04410167-DE		120	152	136	135	94	7			9.5
00840437-DE		150	177	146	160	115		11.4	03350219-DE	150	177		146	160	115	7	2	-	6.00		
00590614-DE				14.3				01750430-DE	182.6				14.3								
00440859-DE																					
00301275-DE	2	195	161	162.5	185	88	10	-	17.0	01200644-DE	2	195	161	162.5	185	88	10	-	-	17.0	
00231662-DE		240	188	200	228	109	12		25.5	00920797-DE		240	188	200	228	109	12			25.5	
00192015-DE										34.0		00741042-DE									

Output AC Reactor



200 V								400 V							
Reference AX-RAO	Dimensions						kg	Reference AX-RAO	Dimensions						kg
	A	B2	C2	D	E	F			A	B2	C2	D	E	F	
01830180-DE	180	85	190	140	55	6	5.5	07300080-DE	120	80	120	80	62	5.5	2.35
01150220-DE	180	85	190	140	55	6	5.5	04600110-DE	180	85	190	140	55	6	5.5
00950320-DE	180	85	205	140	55	6	6.5	03600160-DE	180	85	205	140	55	6	6.5
00630430-DE	180	95	205	140	65	6	9.1	02500220-DE	180	95	205	140	55	6	9.1
00490640-DE	180	95	205	140	65	6	9.1	02000320-DE	180	105	205	140	85	6	11.7
00390800-DE	240	110	275	200	75	6	16.0	01650400-DE	240	110	275	200	75	6	16.0
00330950-DE	240	110	275	200	75	6	16.0	01300480-DE	240	110	275	200	75	6	16.0
00251210-DE	240	110	275	200	75	6	16.0	01030580-DE	240	110	275	200	75	6	16.0
00191450-DE	240	120	275	200	85	6	18.6	00800750-DE	240	120	275	200	85	6	18.6

Chokes

Reference	D diameter	Motor KW	Dimensions						Weight kg
			L	W	H	X	Y	m	
AX-FER2515-RE	25	< 15	105	25	62	90	-	5	0.2
AX-FER5045-RE	50	< 37	150	50	110	125	30	5	0.7

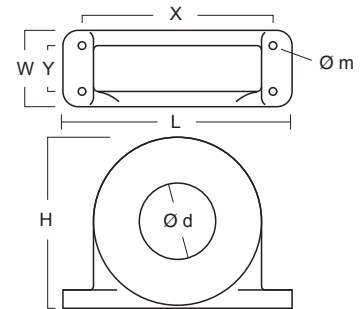

Braking unit dimensions

Reference	Dimensions					
	B	B1	H	H1	T	S
AX-BCR2070130-TE	130	64.5	205	193	208	6
AX-BCR4035090-TE						

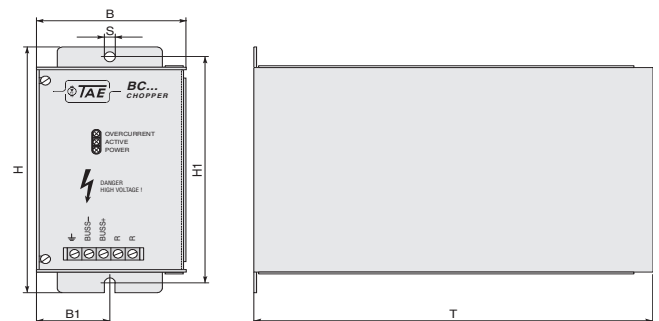

Resistor dimensions

Fig 1

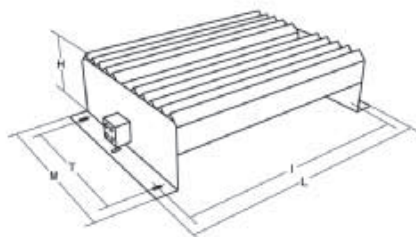
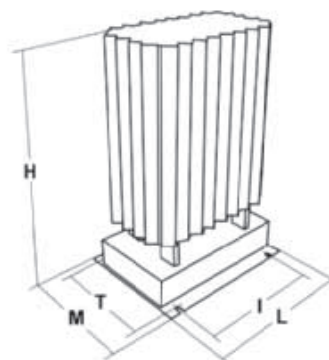
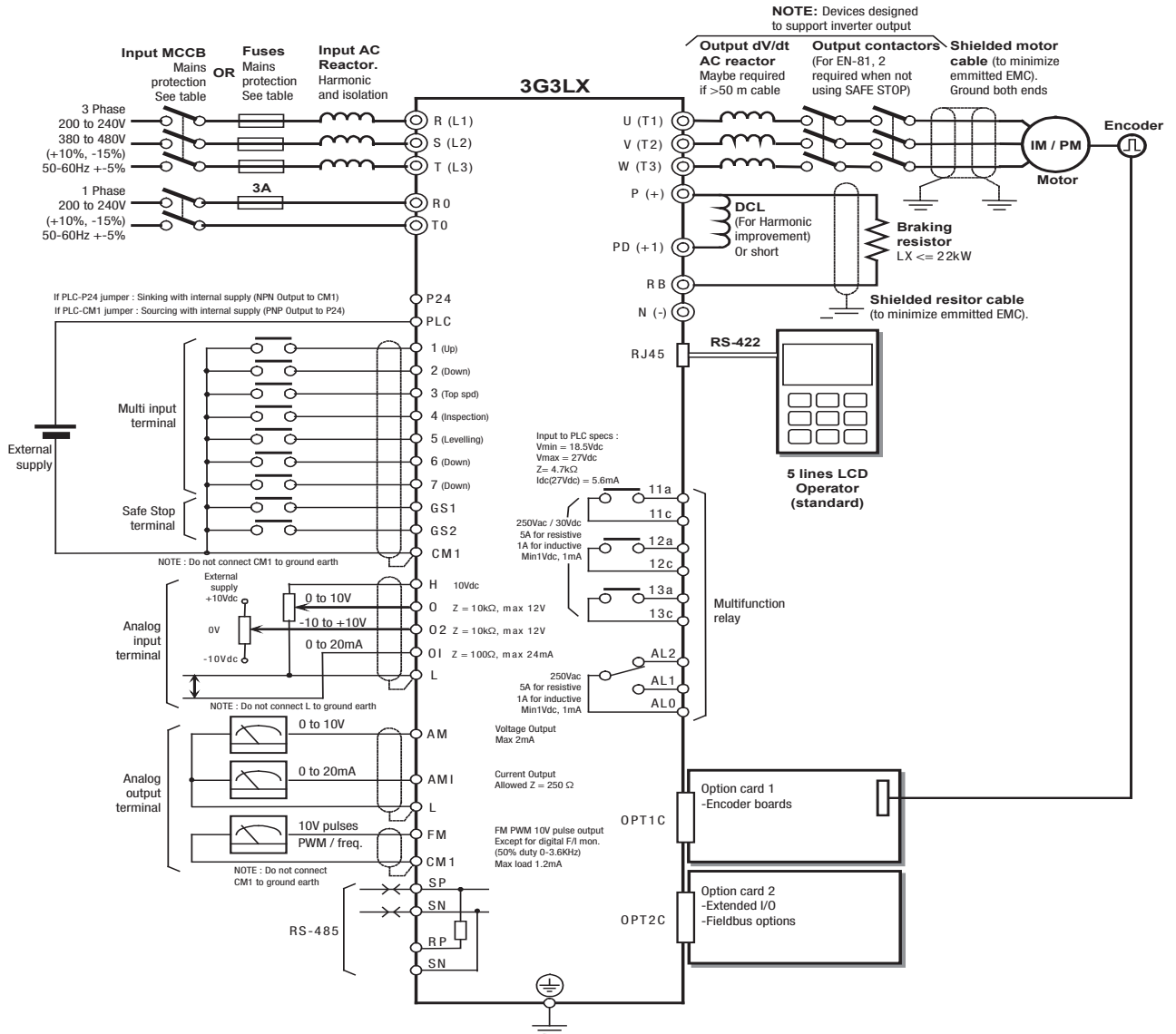

Fig 2



Type	Fig	Dimensions					Weight
		L	H	M	I	T	kg
AX-REM02K1070-IE	1	310	100	240	295	210	7
AX-REM02K1110-IE		365	100	240	350	210	8
AX-REM03K5035-IE							
AX-REM03K5085-IE							
AX-REM19K0006-IE	2	206	350	140	190	50	8.1
AX-REM19K0020-IE							
AX-REM19K0032-IE							

Standard connections



Frequency inverters

Terminal block specifications

Terminal	Name	Function (signal level)
R/L1, S/L2, T/L3	Main circuit power supply input	Three phase 200-240V / 380-480V (depends on voltage class).
Ro, To	Control circuit power supply	Single phase 200-240V for any voltage class
U/T1, V/T2, W/T3	Inverter output	Three phase motor connection (IM/PM)
PD/+1, P/+	External DC reactor terminal	Normally connected by the short-circuit bar. Remove the short-circuit bar between +1 and P/+ when a DC reactor is connected.
P/+, RB	External brake resistor	For connection of an external braking resistor. (Integrated braking transistor for 22KW or lower size)
P/+, N/-	Regenerative braking unit connection terminal	Connect optional regenerative braking units.
⊕	Grounding	Earthing terminal. Please ground large ground.

Control circuit

Type	No.	Signal name	Function	Signal level
Frequency reference input	H	Power supply for analog potentiometer	10 VDC 20 mA max	
	O	Analog voltage input Speed Reference / Torque bias (load cell)	0 to 12 VDC (10 kΩ)	
	O2	Analog voltage input Speed Reference / Torque bias (load cell)	0 to +/- 12 VDC (10 kΩ)	
	OI	Analog current input Speed Reference / Torque bias (load cell)	4 to 20 mA (100 Ω)	
	L	analog power supply common	-	
Monitor Output	AM	Multi-function analog voltage output	Factory setting: Output frequency	2 mA max
	AMI	Multi-function analog current output	Factory setting: Output frequency	4 to 20 mA (max imp 250 Ω)
	FM	PWM monitor output	Factory setting: Output frequency	0 to 10 VDC Max 3.6 kHz
Power Supply	P24	Internal 24 VDC	Power supply for contact input signal	100 mA max
	CM1	Input common	Common terminal for P24, TH and analog monitor (AM, AMI, FM) terminals Note: Do not connect to ground earth	
Function Selection	1	Multi-function input When safety inputs GS1 and GS2 are enabled by hardware dip-switch SW1, multifunction settings 78:GS1 and 79:GS2 are compulsory. When safety inputs are disabled, GS1 and GS2 can be used as standard multifunction inputs.	Factory setting: Up (UP)	27 VDC max Input impd 4.7 kΩ Max current 5.6 mA On: 18 VDC or more
	2		Factory setting: Down (DWN)	
	3		Factory setting: Multi-speed 2 setting (SPD2)	
	4		Factory setting: Inspection 1 (INSP1)	
	5		Factory setting: Leveling signal (LVS)	
	6		Factory setting: Reset (RS)	
	7		Factory setting: Inspection 2 (INSP2)	
	GS1		Factory setting: Gate suppress 1 (GS1)	
	GS2		Factory setting: Gate suppress 2 (GS2)	
	PLC		Multi-function input common	
Status/ Factor	11a	Multi-function output	Factory setting: Brake control signal (BRK)	Maximum relay contact capacity: 250Vac 5A (R load) 250Vac 1A (I load) 30Vdc 5A (R load) 30Vdc 1A (I load) Minimum capacity 1Vdc 1mA
	11c			
	12a		Factory setting: Contactor control signal (CON)	
	12c			
	13a		Factory setting: Inverter ready (IRDY)	
	13c			
Relay output	AL1	Relay output (Normally close)	Factory setting: Alarm signal (AL) Under normal operation AL1-AL0 open AL2-AL0 close	R load AL1-AL0 250 VAC 2 A
	AL2	Relay output (Normally open)		AL2-AL0 250 VAC 1 A
	AL0	Relay output common		I load 250 VAC 0.2 A
Sensor	TH	External thermistor input terminal	SC terminal functions as the common terminal 100 mW minimum Impedance at temperature error: 3 kΩ	0 to 8 VDC
Comms	SP	RS485 Modbus terminals	-	Differential input
	SN			
	RP	RS485 terminating resistor terminals	-	-
	SN			

Inverter heat loss
Three-phase 200 V class

Model 3G3LX-		A2040	A2055	A2075	A2110	A2150	A2185	A2220	A2300	A2370
Inverter capacity kVA	200 V	5.7	8.3	11.0	15.9	22.1	26.3	32.9	41.9	50.2
	240 V	6.8	9.9	13.3	19.1	26.6	31.5	39.4	50.2	60.2
Rated current (A)		16.5	24	32	46	64	76	95	121	145
Heat loss W	Losses at 70% load	179	242	312	435	575	698	820	1100	1345
	Losses at 100% load	235	325	425	600	800	975	1150	1550	1900
Efficiency at rated output		94.0	94.4	94.6	94.8	94.9	95.0	95.0	95.0	95.1
Cooling Method		Forced-air-cooling								

Three-phase 400 V class

Model 3G3LX-		A4037	A4040	A4055	A4075	A4110	A4150	A4185	A4220	A4300	A4370
Inverter capacity kVA	400 V	5.7	5.9	9.7	13.1	17.3	22.1	26.3	33.2	40.1	51.9
	480 V	6.8	7.1	11.6	15.8	20.7	26.6	31.5	39.9	48.2	62.3
Rated current (A)		9	11	14	19	25	32	38	48	58	75
Heat loss W	Losses at 70% load	179	242	242	312	435	575	698	820	1100	1345
	Losses at 100% load	235	325	325	425	600	800	975	1150	1550	1900
Efficiency at rated output		94.0	94.4	94.4	94.6	94.8	94.9	95.0	95.0	95.0	95.1
Cooling Method		Forced-air-cooling									

Input AC Reactor

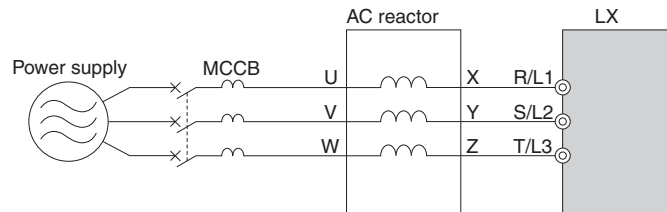

3 phase 200 V class				400 V class			
Max. applicable motor output kW	Reference	Current value A	Inductance mH	Max. applicable motor output kW	Reference	Current value A	Inductance mH
4.0	AX-RAI00880200-DE	20.0	0.88	3.7	AX-RAI03500100-DE	10.0	3.5
5.5 to 7.5	AX-RAI00350335-DE	33.5	0.35	4.0, 5.5 to 7.5	AX-RAI01300170-DE	17.0	1.3
11.0 to 15.0	AX-RAI00180670-DE	67.0	0.18	11.0 to 15.0	AX-RAI00740335-DE	33.5	0.74
18.5 to 22.0	AX-RAI00091000-DE	100.0	0.09	18.5 to 22.0	AX-RAI00360500-DE	50.0	0.36
30.0 to 37.0	AX-RAI00071550-DE	155.0	0.07	30.0 to 37.0	AX-RAI00290780-DE	78.0	0.29

DC Reactor

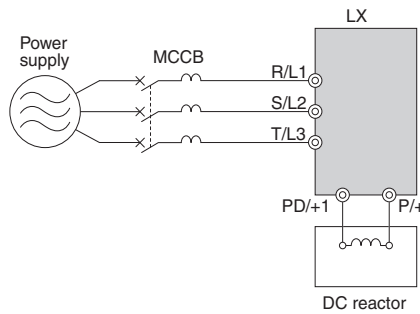

200 V class				400 V class			
Max. applicable motor output kW	Reference	Current value A	Inductance mH	Max. applicable motor output kW	Reference	Current value A	Inductance mH
4.0	AX-RC01600223-DE	22.3	1.60	4.0	AX-RC06400116-DE	11.6	6.40
5.5	AX-RC01110309-DE	30.9	1.11	5.5	AX-RC04410167-DE	16.7	4.41
7.5	AX-RC00840437-DE	43.7	0.84	7.5	AX-RC03350219-DE	21.9	3.35
11.0	AX-RC00590614-DE	61.4	0.59	11.0	AX-RC02330307-DE	30.7	2.33
15.0	AX-RC00440859-DE	85.9	0.44	15.0	AX-RC01750430-DE	43.0	1.75
18.5 to 22	AX-RC00301275-DE	127.5	0.30	18.5 to 22	AX-RC01200644-DE	64.4	1.20
30	AX-RC00231662-DE	166.2	0.23	30	AX-RC00920797-DE	79.7	0.92
37	AX-RC00192015-DE	201.5	0.19	37	AX-RC00741042-DE	104.2	0.74

Output AC Reactor

200 V class				400 V class			
Max. applicable motor output kW	Reference	Current value A	Inductance mH	Max. applicable motor output kW	Reference	Current value A	Inductance mH
4.0	AX-RAO01830160-DE	16.0	1.83	4.0	AX-RAO07300080-DE	8.0	7.30
5.5	AX-RAO01150220-DE	22.0	1.15	5.5	AX-RAO04600110-DE	11.0	4.60
7.5	AX-RAO00950320-DE	32.0	0.95	7.5	AX-RAO03600160-DE	16.0	3.60
11	AX-RAO00630430-DE	43.0	0.63	11	AX-RAO02500220-DE	22.0	2.50

200 V class				400 V class			
Max. applicable motor output kW	Reference	Current value A	Inductance mH	Max. applicable motor output kW	Reference	Current value A	Inductance mH
15	AX-RAO00490640-DE	64.0	0.49	15	AX-RAO02000320-DE	32.0	2.00
18.5	AX-RAO00390800-DE	80.0	0.39	18.5	AX-RAO01650400-DE	40.0	1.65
22	AX-RAO00330950-DE	95.0	0.33	22	AX-RAO01300480-DE	48.0	1.30
30	AX-RAO00251210-DE	121.0	0.25	30	AX-RAO01030580-DE	58.0	1.03
37	AX-RAO00191450-DE	145.0	0.19	37	AX-RAO00800750-DE	75.0	0.80

Braking Unit

Voltage	Reference	Specifications				Minimum connectable resistor (Ohms)
		Permanent		Peak (5s max)		
		Current (A)	Brake power (kVA)	Current (A)	Brake power (kVA)	
200 V	AX-BCR2070130-TE	70	25	130	47	2.8
400 V	AX-BCR4035090-TE	35	26	90	67	8.5

Ordering information

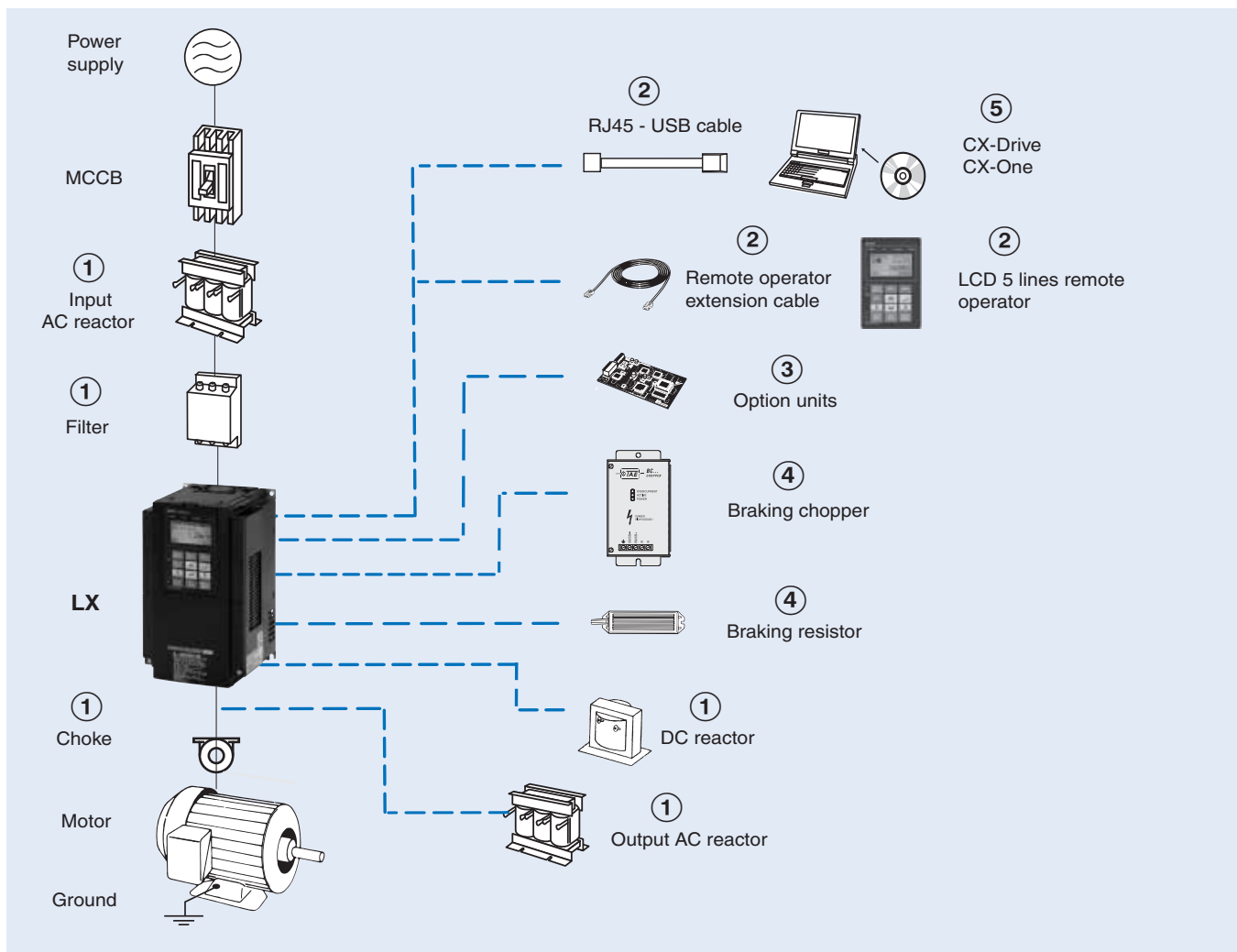

Frequency inverters

LX

Specifications			Model	Specifications			Model
Voltage class	Max motor kW	Rated current A	3G3LX-	Voltage class	Max motor kW	Rated current A	3G3LX-
Three-phase 200 V	-	-	-	Three-phase 400V	3.7	9	A4037-E
	4.0	17.5	A2037-E		4.0	11	A4040-E
	5.5	25	A2055-E		5.5	14	A4055-E
	7.5	33	A2075-E		7.5	19	A4075-E
	11	49	A2110-E		11	27	A4110-E
	15	64	A2150-E		15	34	A4150-E
	18.5	80	A2185-E		18.5	41	A4185-E
	22	96	A2220-E		22	48	A4220-E
	30	130	A2300-E	30	65	A4300-E	
	37	160	A2370-E	37	80	A4370-E	

① Line filters

Line filter									
200V					400V				
Model 3G3LX-□	Reference	Rated current (A)	Leakage Nom / Max	Kg	Model 3G3LX-□	Reference	Rated current (A)	Leakage Nom / Max	Kg
A2040	Under development				A4037	AX-FIL3010-SE	10	3.3/53 mA	1.0
A2055 / A2075 / A2110					A4040	AX-FIL3015-SE	15	3.3/53 mA	1.5
A2150/ A2185/ A2220					A4055 / A4075 / A4110	AX-FIL3030-SE	30	3.4/58 mA	2.1
A2300					A4150/ A4185/ A4220	AX-FIL3053-SE	53	3.4/58 mA	4.1
A2370					A4300 / A4370	AX-FIL3089-SE	89	3.4/58 mA	4.7

① Input AC Reactors

Voltage			
3-Phase 200 VAC		3-Phase 400 VAC	
Inverter Model 3G3LX-□	AC Reactor Reference	Inverter Model 3G3LX-□	AC Reactor Reference
A2040	AX-RAI00880200-DE	A4037 / A4040	AX-RAI03500100-DE
A2055 / A2075	AX-RAI00350335-DE	A4055 / A4075	AX-RAI01300170-DE
A2110 / A2150	AX-RAI00180670-DE	A4110 / A4150	AX-RAI00740335-DE
A2185 / A2220	AX-RAI00091000-DE	A4185 / A4220	AX-RAI00360500-DE
A2300 / A2370	AX-RAI00071550-DE	A4300 / A4370	AX-RAI00290780-DE

① DC Reactors

Voltage			
3-Phase 200 VAC		3-Phase 400 VAC	
Inverter Model 3G3LX-□	AC Reactor Reference	Inverter Model 3G3LX-□	AC Reactor Reference
A2040	AX-RC01600223-DE	A4037	AX-RC06400116-DE
A2055	AX-RC01110309-DE	A4040 / A4055	AX-RC04410167-DE
A2075	AX-RC00840437-DE	A4075	AX-RC03350219-DE
A2110	AX-RC00590614-DE	A4110	AX-RC02330307-DE
A2150	AX-RC00440859-DE	A4150	AX-RC01750430-DE
A2185 / A2220	AX-RC00301275-DE	A4185 / A4220	AX-RC01200644-DE
A2300	AX-RC00231662-DE	A4300	AX-RC00920797-DE
A2370	AX-RC00192015-DE	A4370	AX-RC00741042-DE

① Chokes

Model	Diameter	Description
AX-FER2515-RE	25	For 15 kW motors or below
AX-FER5045-RE	50	For 37 kW motors or below

① Output AC Reactor

Voltage			
200V		400V	
Model 3G3LX-□	Reference	Model 3G3LX-□	Reference
A2037	AX-RAO01830160-DE	A4040	AX-RAO07300080-DE
A2055	AX-RAO01150220-DE	A4055	AX-RAO04600110-DE
A2075	AX-RAO00950320-DE	A4075	AX-RAO03600160-DE
A2110	AX-RAO00630430-DE	A4110	AX-RAO02500220-DE
A2150	AX-RAO00490640-DE	A4150	AX-RAO02000320-DE
A2185	AX-RAO00390800-DE	A4185	AX-RAO01650400-DE
A2220	AX-RAO00330950-DE	A4220	AX-RAO01300480-DE
A2300	AX-RAO00251210-DE	A4300	AX-RAO01030580-DE
A2370	AX-RAO00191450-DE	A4370	AX-RAO00800750-DE

② Accessories

Types	Model	Description	Functions
Digital operator	AX-OP05-E	LCD remote operator	5 Line LCD remote operator with copy function, cable length max. 3m. ^{*1}
	3G3AX-CAJOP300-EE	Remote operator cable	3 meters cable for connecting remote operator
	3G3AX-OP01	LED remote operator	LED remote operator, cable length max. 3m
	4X-KITMINI	Mounting kit for LED operator	Mounting kit for LED operator on panel
Accessories	3G3AX-PCACN2	USB converter / USB cable	RJ45 to USB connection cable
	USB-convertercable		

*1 please note, models with firmware 4287 and 4288, the operator will only display 2 lines of text.

③ Option boards

Types	Model	Description	Functions
Encoder Feedback	3G3AX-PG	PG speed controller option card	Phase A,B and Z pulse (differential pulse) inputs (RS-422) Pulse train position command input (RS-422) Pulse monitor output (RS-422) PG frequency range: 100 kHz max
	3G3AX-ABS		Two encoder input board supporting Phase A,B and Z pulse (differential pulse) inputs (RS-422) EnDat 2.1 and 2.2 Hiperface
	3G3AX-ABSGL		3G3AX-ABS --> PG frequency range: 100 kHz max 3G3AX-ABSGL --> PG frequency range: 30 KHz max to improve noise immunity
Option	SJ-EIO	Expansion I/O board	5 digital inputs, 2 relay output and 1 open collector output

④ Braking unit, braking resistor unit

Voltage	Max. motor kW	Inverter				Braking resistor unit		
		Inverter 3G3LX□	Braking Unit AX-BCR□	Connectable min. resistance Ω	Connectable resistance at continuous running Ω	External resistor 10%ED 10 sec max for built-in 5 sec max for Braking Unit		Braking torque %
		3-phase				Type AX-	Resist Ω	
200 V (Three-phase)	4.0	2037	Built-in	24	100	REM02K1070-IE	70	50
	5.5	2055		16	50	REM02K1070-IE	70	40
	7.5	2075		10	50	REM03K5035-IE	35	45
	11.0	2110		10	50	REM03K5035-IE	35	30
	15.0	2150		7.5	35	REM19K0020-IE	20	65
	18.5	2185		7.5	35	REM19K0020-IE	20	55
	22.0	2220		5	35	REM19K0020-IE	20	45
	30.0	2300	2070130-TE	2.8	5.6	2x REM19K0006-IE	3	50
37.0	2370	40						
400 V (Three-phase)	3.7	4037	Built-in	70	200	REM02K1110-IE	110	55
	4.0	4040		70	200	REM02K1110-IE	110	50
	5.5	4055		70	200	REM02K1110-IE	110	40
	7.5	4075		35	150	REM03K5085-IE	85	45
	11.0	4110		35	150	REM03K5085-IE	85	30
	15.0	4150		24	100	REM19K0032-IE	32	65
	18.5	4185		24	100	REM19K0032-IE	32	55
	22.0	4220	20	100	REM19K0032-IE	32	45	
	30.0	4300	4035090-TE	8.5	22	2x REM19K0020-IE	10	50
	37.0	4370						40

Recommended values with a 2:1 roping ratio, 1m/s lift speed and medium lift usage

⑤ Computer software

Types	Model	Description	Installation
Software	CX-drive	Computer software	Configuration and monitoring software tool
	CX-One	Computer software	Configuration and monitoring software tool

ALL DIMENSIONS SHOWN ARE IN MILLIMETERS.

To convert millimeters into inches, multiply by 0.03937. To convert grams into ounces, multiply by 0.03527.

MX2

Born to drive machines

- Current vector control
- High starting torque: 200% at 0.5 Hz
- Double rating VT 120%/1 min and CT 150%/1 min
- Speed range up to 1000 Hz
- IM & PM motor control
- Torque control in open loop vector
- Positioning functionality
- Built-in application functionality (i.e. Brake control)
- Built-in logic programming
- Safety embedded compliant with ISO13849-1 (double input circuit and external device monitor EDM)
- USB port for PC programming
- 24 VDC backup supply for control board
- Fieldbus communications: Modbus, DeviceNet, Profibus, Componet, Ethercat, ML-II and Ethernet/IP
- PC configuration tool: CX-Drive
- RoHS, CE, cULus

Ratings

- 200 V Class single-phase 0.1 to 2.2 kW
- 200 V Class three-phase 0.1 to 15.0 kW
- 400 V Class three-phase 0.4 to 15.0 kW



System configuration

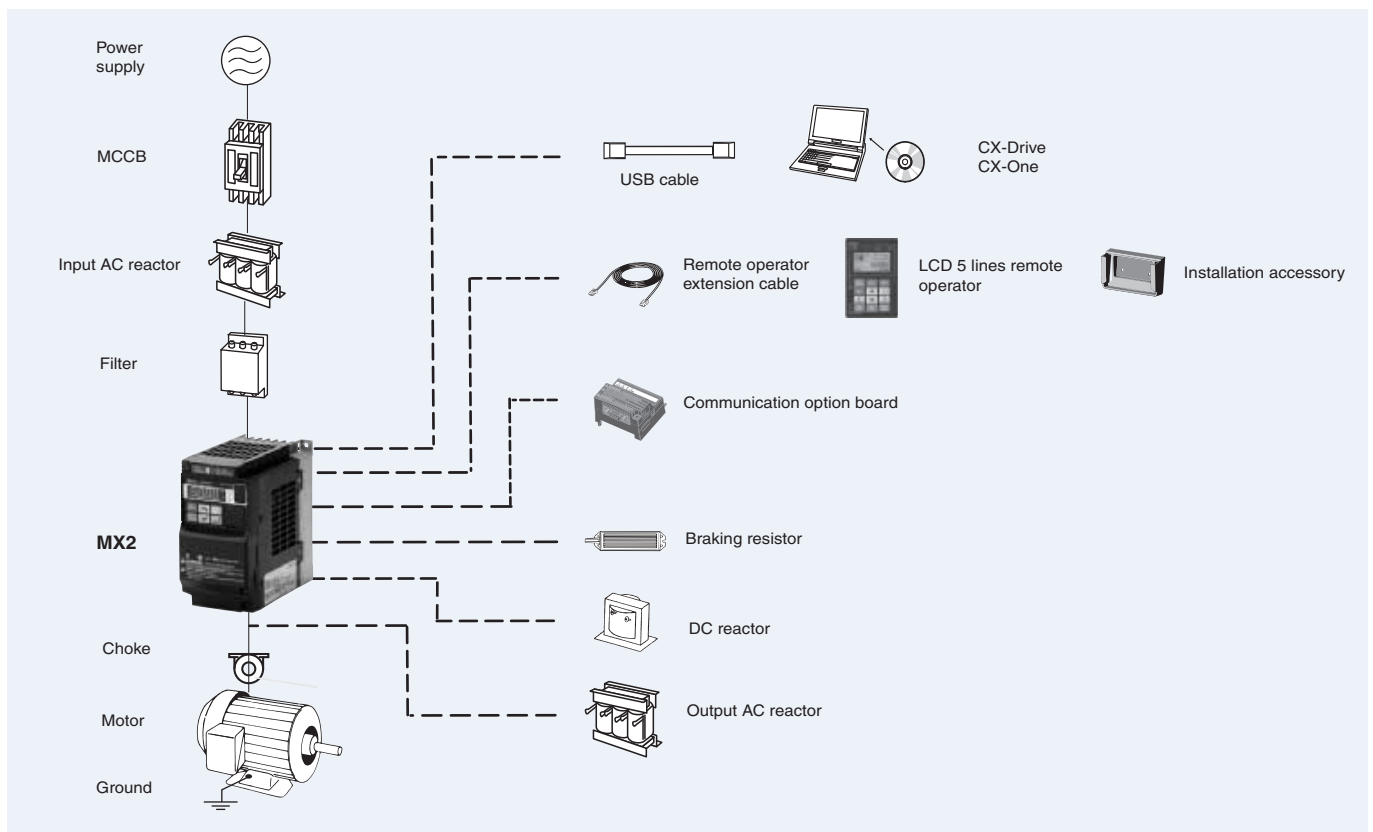

Specifications

Type designation

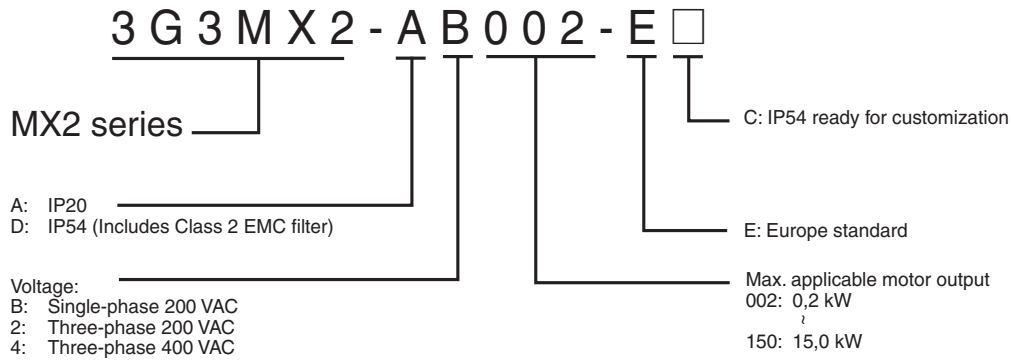

200 V class

Single-phase: 3G3MX2-□		B001	B002	B004	B007 ¹	B015	B022	-	-	-	-	-	
Three-phase: 3G3MX2-□		2001	2002	2004	2007	2015	2022	2037	2055	2075	2110	2150	
Motor kW ²	For VT setting	0.2	0.4	0.55	1.1	2.2	3.0	5.5	7.5	11	15	18.5	
	For CT setting	0.1	0.2	0.4	0.75	1.5	2.2	3.7	5.5	7.5	11	15	
Output characteristics	Inverter capacity kVA	200 VT	0.4	0.6	1.2	2.0	3.3	4.1	6.7	10.3	13.8	19.3	23.9
		200 CT	0.2	0.5	1.0	1.7	2.7	3.8	6.0	8.6	11.4	16.2	20.7
		240 VT	0.4	0.7	1.4	2.4	3.9	4.9	8.1	12.4	16.6	23.2	28.6
		240 CT	0.3	0.6	1.2	2.0	3.3	4.5	7.2	10.3	13.7	19.5	24.9
	Rated output current (A) at VT		1.2	1.9	3.5	6.0	9.6	12.0	19.6	30.0	40.0	56.0	69.0
Rated output current (A) at CT		1.0	1.6	3.0	5.0	8.0	11.0	17.5	25.0	33.0	47.0	60.0	
Max. output voltage		Proportional to input voltage: 0..240 V											
Max. output frequency		1000 Hz ³											
Power supply	Rated input voltage and frequency		Single-phase 200..240 V 50/60 Hz 3-phase 200..240 V 50/60 Hz										
	Allowable voltage fluctuation		-15%..+10%										
	Allowable frequency fluctuation		5%										
Braking torque	At short-time deceleration At capacitor feedback	100%: <50Hz 50%: <60Hz				70%: <50Hz 50%: <60Hz		Approx 20%		-			
		Cooling method					Self cooling ⁴		Forced-air-cooling				

1. Three phase model use forced-air-cooling but single phase model is self cooling.
2. Based on a standard 3-Phase standard motor.
3. Above 400 Hz with some function limitation.
4. Forced air cooling for IP54 models

400 V class

Three-phase: 3G3MX2-□		4004	4007	4015	4022	4030	4040	4055	4075	4110	4150	
Motor kW ¹	For VT setting	0.75	1.5	2.2	3.0	4.0	5.5	7.5	11	15	18.5	
	For CT setting	0.4	0.75	1.5	2.2	3.0	4.0	5.5	7.5	11	15	
Output characteristics	Inverter capacity kVA	380 VT	1.3	2.6	3.5	4.5	5.7	7.3	11.5	15.1	20.4	25.0
		380 CT	1.1	2.2	3.1	3.6	4.7	6.0	9.7	11.8	15.7	20.4
		480 VT	1.7	3.4	4.4	5.7	7.3	9.2	14.5	19.1	25.7	31.5
		480 CT	1.4	2.8	3.9	4.5	5.9	7.6	12.3	14.9	19.9	25.7
	Rated output current (A) at VT		2.1	4.1	5.4	6.9	8.8	11.1	17.5	23.0	31.0	38.0
Rated output current (A) at CT		1.8	3.4	4.8	5.5	7.2	9.2	14.8	18.0	24.0	31.0	
Max. output voltage		Proportional to input voltage: 0..480 V										
Max. output frequency		1000 Hz ²										
Power supply	Rated input voltage and frequency		3-phase 380..480 V 50/60 Hz									
	Allowable voltage fluctuation		-15%..+10%									
	Allowable frequency fluctuation		5%									
Braking torque	At short-time deceleration ^{*3} At capacitor feedback	100%: <50Hz 50%: <60Hz				70%: <50Hz 50%: <60Hz		-				
		Cooling method					Self cooling ³		Forced-air-cooling			

1. Based on a standard 3-Phase standard motor.
2. Above 400 Hz with some function limitation.
3. Forced air cooling for IP54 models

Specifications

Common specifications

Model number 3G3MX2		Specifications	
Control functions	Control methods	Phase-to-phase sinusoidal pulse with modulation PWM (Sensorless vector control, V/F)	
	Output frequency range	0.10..1000.00 Hz (with restrictions above 400Hz)	
	Frequency precision	Digital set value: ±0.01% of the max. frequency	
		Analogue set value: ±0.2% of the max. frequency (25 ±10°C)	
	Resolution of frequency set value	Digital set value: 0.01 Hz Analogue set value: 1/1000 of maximum frequency	
	Resolution of output frequency	0.01Hz	
	Starting torque	200% / 0.5 Hz	
	Overload capability	Dual rating: Heavy duty (CT): 150% for 1 minute Normal Duty (VT): 120% for 1 minute	
	Frequency set value	0 to 10 VDC (10 KΩ), 4 to 20 mA (100 Ω), RS485 Modbus, Network options	
V/f Characteristics	Constant/ reduced torque, free V/f		
Functionality	Inputs signals	FW (forward run command), RV (reverse run command), CF1~CF4 (multi-stage speed setting), JG (jog command), DB (external braking), SET (set second motor), 2CH (2-stage accel./decel. command), FRS (free run stop command), EXT (external trip), USP (startup function), CS (commercial power switchover), SFT (soft lock), AT (analog input selection), RS (reset), PTC (thermistor thermal protection), STA (start), STP (stop), F/R (forward/reverse), PID (PID disable), PIDC (PID reset), UP (remote control up function), DWN (remote control down function), UDC (remote control data clear), OPE (operator control), SF1~SF7 (multi-stage speed setting; bit operation), OLR (overload restriction), TL (torque limit enable), TRQ1 (torque limit changeover1), TRQ2 (torque limit changeover2), BOK (Braking confirmation), LAC (LAD cancellation), PCLR (position deviation clear), ADD (add frequency enable), F-TM (force terminal mode), ATR (permission of torque command input), KHC (Cumulative power clear), MI1~MI7 (general purpose inputs for EzSQ), AHD (analog command hold), CP1~CP3 (multistage-position switches), ORL (limit signal of zero-return), ORC (trigger signal of zero-return), SPD (speed/position changeover), GS1~GS2 (STO inputs, safety related signals), 485 (Starting communication signal), PRG (executing EzSQ program), HLD (retain output frequency), ROK (permission of run command), EB (rotation direction detection of B-phase), DISP (display limitation), OP (option control signal), NO (no function)	
	Output signals	RUN (run signal), FA1~FA5 (frequency arrival signal), OL,OL2 (overload advance notice signal), OD (PID deviation error signal), AL (alarm signal), OTQ (over/under torque threshold), UV (under-voltage), TRQ (torque limit signal), RNT (run time expired), ONT (power ON time expired), THM (thermal warning), BRK (brake release), BER (brake error), ZS (0Hz detection), DSE (speed deviation excessive), POK (positioning completion), ODc (analog voltage input disconnection), OIdc (analog current input disconnection), FBV (PID second stage output), NDc (network disconnect detection), LOG1~LOG3 (Logic output signals), WAC (capacitor life warning), WAF (cooling fan warning), FR (starting contact), OHF (heat sink overheat warning), LOC (Low load), MO1~MO3 (general outputs for EzSQ), IRDY (inverter ready), FWR (forward operation), RVR (reverse operation), MJA (major failure), WCO (window comparator O), WCOI (window comparator OI), FREF (frequency command source), REF (run command source), SETM (second motor in operation), EDM (STO (safe torque off) performance monitor), OP (option control signal), NO (no function)	
	Standard functions	Free-V/f, manual/automatic torque boost, output voltage gain adjustment, AVR function, reduced voltage start, motor data selection, auto-tuning, motor stabilization control, reverse running protection, simple position control, simple torque control, torque limiting, automatic carrier frequency reduction, energy saving operation, PID function, non-stop operation at instantaneous power failure, brake control, DC injection braking, dynamic braking (BRD), frequency upper and lower limiters, jump frequencies, curve accel and decel (S, U, inverted U,EL-S), 16-stage speed profile, fine adjustment of start frequency, accel and decel stop, process jogging, frequency calculation, frequency addition, 2-stage accel/decel, stop mode selection, start/end freq., analog input filter, window comparators, input terminal response time, output signal delay/hold function, rotation direction restriction, stop key selection, software lock, safe stop function, scaling function, display restriction, password function, user parameter, initialization, initial display selection, cooling fan control, warning, trip retry, frequency pull-in restart, frequency matching, overload restriction, over current restriction, DC bus voltage AVR	
	Analogue inputs	2 analogue inputs 0 to 10 V (10 KΩ), 4 to 20 mA (100 Ω)	
	Pulse train input terminal	0 to 10 V (up to 24 V), up to 32 kHz	
	Accel/Decel times	0.01 to 3600.0 s (line/curve selection), 2nd accel/decel setting available	
	Display	Status indicator LED's Run, Program, Alarm, Power, Hz, Amps Digital operator: Available to monitor 32 items: frequency reference, output current, output frequency...	
	Protection functions	Motor overload protection	Electronic Thermal overload relay and PTC thermistor input
		Instantaneous overcurrent	200% of rated current
		Overload	Dual rating: Heavy duty (CT): 150% for 1 minute Normal Duty (VT): 120% for 1 minute
Overvoltage		800 V for 400 V type and 400 V for 200 V type	
Undervoltage		345 V for 400 V type and 172.5 V for 200 V type	
Momentary power loss		Following items are selectable: Alarm, decelerates to stop, decelerates to stop with DC bus controlled, restart	
Cooling fin overheat		Temperature monitor and error detection	
Stall prevention level		Stall prevention during acceleration/deceleration and constant speed	
Ground fault		Detection at power-on	
Power charge indication	On when power is supplied to the control part		
Ambient conditions	Degree of protection	IP20, Varnish coating on PCB & IP54 (For 3G3MX2-D□ type)	
	Ambient humidity	90% RH or less (without condensation)	
	Storage temperature	-20°C..+65°C (short-term temperature during transportation)	
	Ambient temperature ¹	-10°C to 50°C (Both the carrier frequency and output current need to be reduced over 40°C)	
	Installation	Indoor (no corrosive gas, dust, etc.)	
	Installation height	Max. 1000 m	
Vibration	5.9 m/s ² (0.6G), 10 to 55 Hz		

1. Some types of 3G3MX2-D requires special derating depending on installation conditions and carrier frequency selected. Check the manual for details

Dimensions

IP20

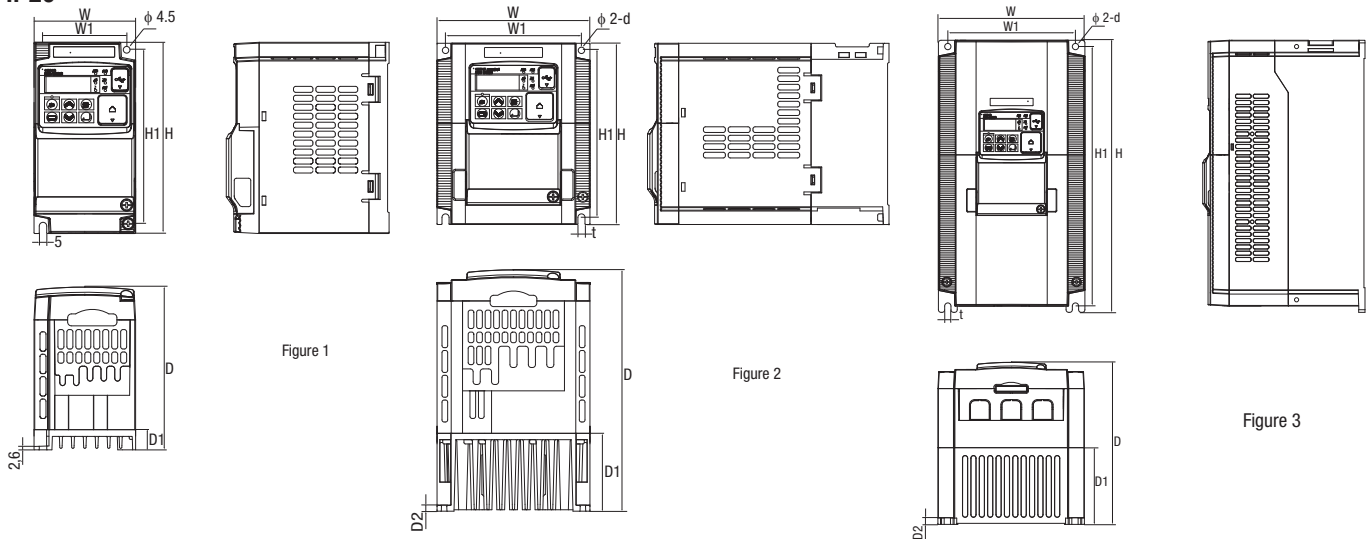

Voltage class	Inverter model 3G3MX2-A□	Figure	Dimensions in mm																		
			W	W1	H	H1	t	D	D1	D2	d	Weight (KG)									
Single-phase 200 V	B001	1	68	56	128	118	-	109	13.5	-	-	1.0									
	B002	1						123	27				1.0								
	B004	1						123	27				1.1								
	B007	2						170.5	55				4.4	4.5	1.4						
	B015	2						170.5	55				4.4	4.5	1.8						
B022	2	170.5	55	4.4	4.5	1.8															
Three-phase 200 V	2001	1	68	56	128	118	-	109	13.5	-	-	1.0									
	2002	1						113	27				1.0								
	2004	1						113	27				1.1								
	2007	1						146	50				1.2								
	2015	2						170.5	55				4.4	4.5	1.6						
	2022	2						170.5	55				4.4	4.5	1.8						
	2037	3						140	128				128	118	5	170.5	55	4.4	2.0		
	2055	3						140	122				260	248	6	155	73.3	6	6	3.0	
	2075	3						140	122				260	248	6	155	73.3	6	6	3.4	
Three-phase 400 V	2110	3	180	160	296	284	7	175	97	5	7	5.1									
	2150	3	220	192	350	336	7	175	84	5	7	7.4									
	4004	2	108	96	128	118	-	144	28	-	-	1.5									
	4007	2						171					1.6								
	4015	2						171					1.8								
	4022	2						171					1.9								
	4030	2						171					1.9								
	4040	3						140					128	128	118	5	171	55	4.4	4.5	2.1
	4055	3						140					122	260	248	6	155	73.3	6	6	3.5
4075	3	140						122					260	248	6	155	73.3	6	6	3.5	
4110	3	180						160					296	284	7	175	97	5	7	4.7	
4150	3	180	160	296	284	7	175	97	5	7	5.2										

Option board

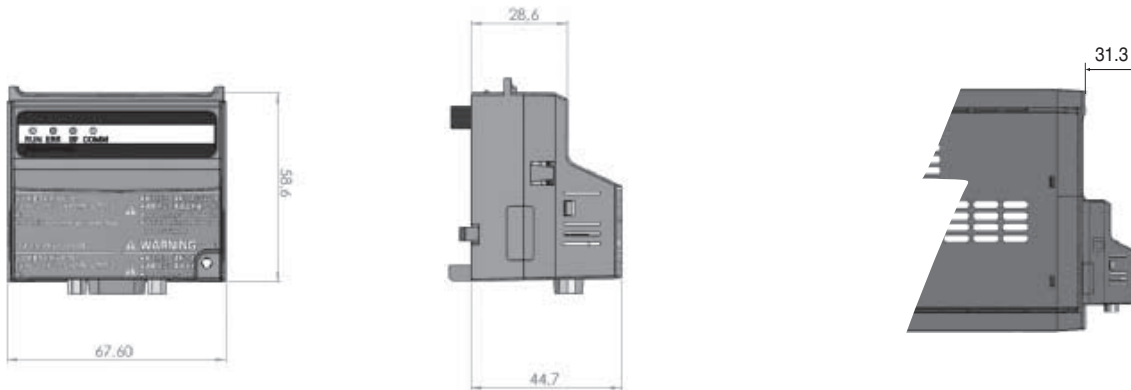

Note: Option boards could be fitted inside the IP54 model

IP54

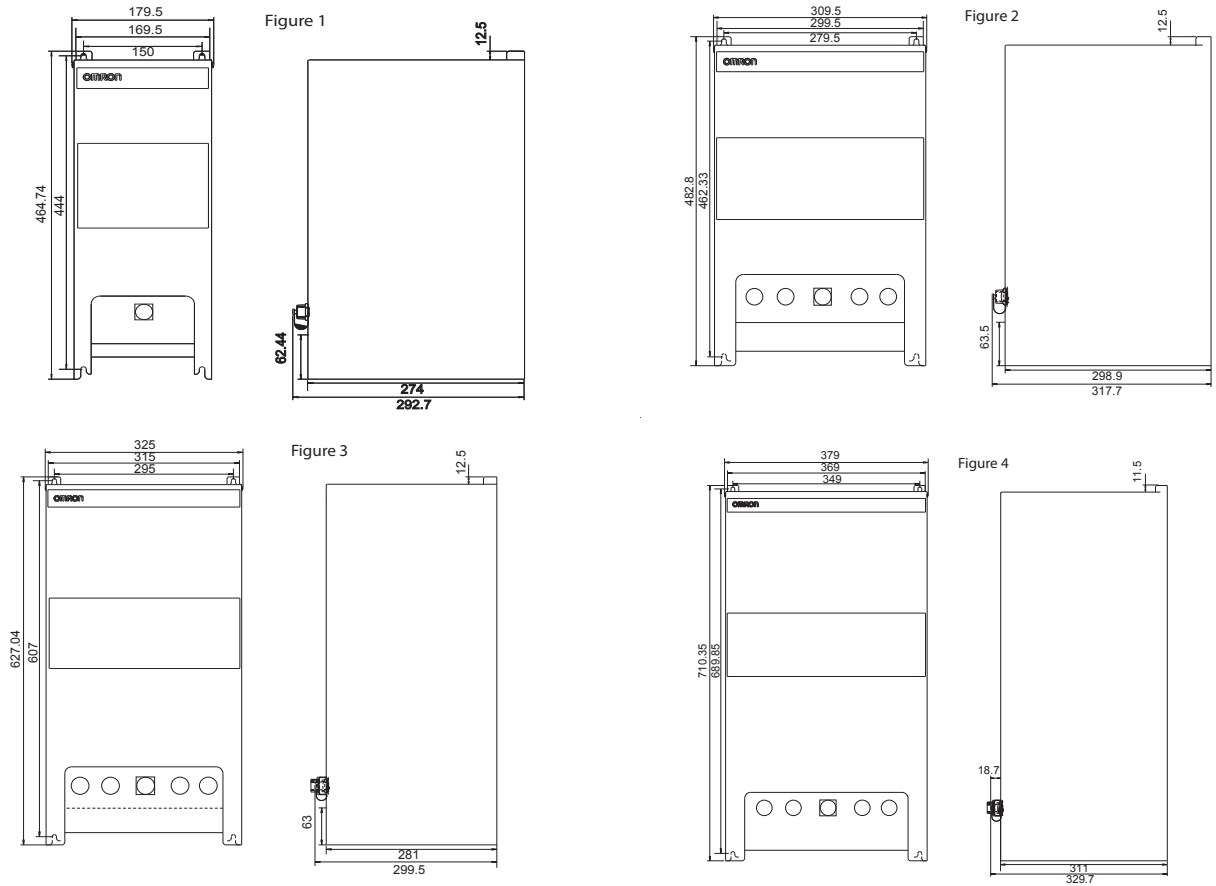
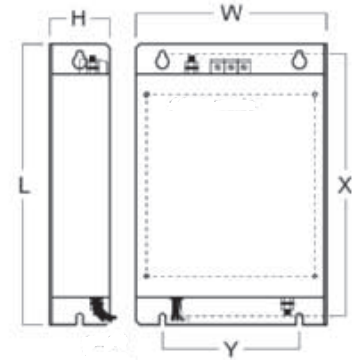

Figure 1	Figure 2	Figure 3	Figure 4
3G3MX2-DB001-E	3G3MX2-DB001-EC	3G3MX2-D2055-EC	3G3MX2-D2110-EC
3G3MX2-DB002-E	3G3MX2-DB002-EC	3G3MX2-D2075-EC	3G3MX2-D2150-EC
3G3MX2-DB004-E	3G3MX2-DB004-EC	3G3MX2-D4055-EC	3G3MX2-D4110-EC
3G3MX2-D2001-E	3G3MX2-DB007-EC	3G3MX2-D4075-EC	3G3MX2-D4150-EC
3G3MX2-D2002-E	3G3MX2-DB015-EC		
3G3MX2-D2004-E	3G3MX2-DB022-EC		
3G3MX2-D2007-E	3G3MX2-D2001-EC		
	3G3MX2-D2002-EC		
	3G3MX2-D2004-EC		
	3G3MX2-D2007-EC		
	3G3MX2-D2015-EC		
	3G3MX2-D2022-EC		
	3G3MX2-D2037-EC		
	3G3MX2-D4004-EC		
	3G3MX2-D4007-EC		
	3G3MX2-D4015-EC		
	3G3MX2-D4022-EC		
	3G3MX2-D4030-EC		
	3G3MX2-D4040-EC		

Rasmi footprint filters

Rasmi model		Dimensions					
		W	H	L	X	Y	M
1x200 V	AX-FIM1010-RE	71	45	169	156	51	M4
	AX-FIM1014-RE	111	50	169	156	91	M4
	AX-FIM1024-RE	111	50	169	156	91	M4
3x200 V	AX-FIM2010-RE	82	50	194	181	62	M4
	AX-FIM2020-RE	111	50	169	156	91	M4
	AX-FIM2030-RE	144	50	174	161	120	M4
	AX-FIM2060-RE	150	52	320	290	122	M5
	AX-FIM2080-RE	188	62	362	330	160	M5
3x400 V	AX-FIM2100-RE	220	62	415	380	192	M6
	AX-FIM3005-RE	114	46	169	156	91	M4
	AX-FIM3010-RE	114	46	169	156	91	M4
	AX-FIM3014-RE	144	50	174	161	120	M4
	AX-FIM3030-RE	150	52	306	290	122	M5
AX-FIM3050-RE	182	62	357	330	160	M5	



Schaffner footprint filters

Rasmi model		Dimensions							
		W	H	L	X	Y	A	B	M
1x200 V	AX-FIM1010-SE-V1	70	40	166	156	51	150	50	M5
	AX-FIM1024-SE-V1	110	50	166	156	91	150	80	M5
3x200 V	AX-FIM2010-SE-V1	80	40	191	181	62	150	50	M5
	AX-FIM2020-SE-V1	110	50	160	156	91	150	80	M5
	AX-FIM2030-SE-V1	142	50	171	161	120	150	112	M5
	AX-FIM2060-SE-V1	140	55	304	290	122	286	112	M5
	AX-FIM2080-SE-V1	180	55	344	330	160	323	140	M5
3x400 V	AX-FIM2100-SE-V1	220	65	394	380	192	376	180	M5
	AX-FIM3005-SE-V1	110	50	166	156	91	150	80	M5
	AX-FIM3010-SE-V1	110	50	166	156	91	150	80	M5
	AX-FIM3014-SE-V1	142	50	171	161	120	150	112	M5
	AX-FIM3030-SE-V1	140	55	304	290	122	286	112	M5
AX-FIM3050-SE-V1	180	55	344	330	160	323	140	M5	

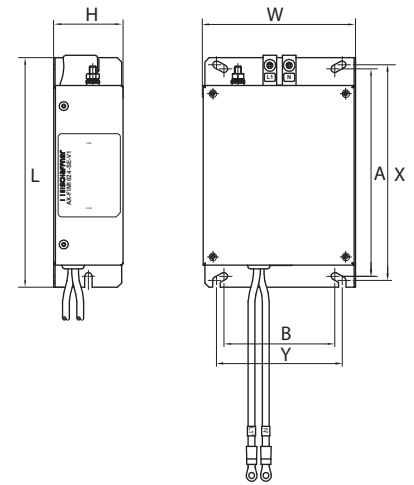

Input AC Reactor

Voltage	Reference	Dimensions						Weight kg
		A	B2	C2	D	E	F	
200 V	AX-RAI02800080-DE	120	70	120	80	52	5.5	1.78
	AX-RAI00880200-DE	120	80	120	80	62	5.5	2.35
	AX-RAI00350335-DE	180	85	190	140	55	6	5.5
	AX-RAI00180670-DE	180	85	190	140	55	6	5.5
400 V	AX-RAI07700050-DE	120	70	120	80	52	5.5	1.78
	AX-RAI03500100-DE	120	80	120	80	62	5.5	2.35
	AX-RAI01300170-DE	120	80	120	80	62	5.5	2.50
	AX-RAI00740335-DE	180	85	190	140	55	6	5.5

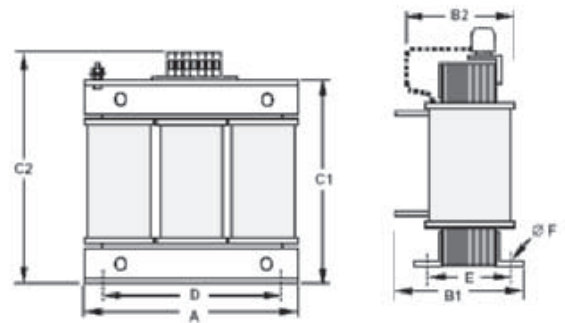

DC Reactor

Voltage	Reference	Dimensions								Weight kg
		A	B	C	D	E	F	G	H	
200 V	AX-RC21400016-DE	84	113	96	101	66	5	7.5	2	1.22
	AX-RC10700032-DE									
	AX-RC06750061-DE									
	AX-RC03510093-DE									
	AX-RC02510138-DE	108	135	116	120	82	6.5	9.5	1.95	
	AX-RC01600223-DE									
	AX-RC01110309-DE									
	AX-RC00840437-DE	120	152	136	135	94	7	9.5	-	5.20
	AX-RC00590614-DE									
	AX-RC00440859-DE	150	177	146	160	115	-	2	-	6.00
AX-RC00440859-DE										
				160						11.4
				182.6						14.3

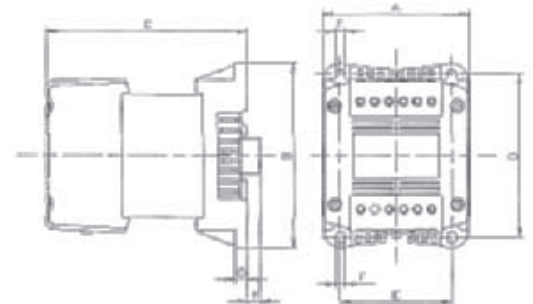

Voltage	Reference	Dimensions								Weight kg
		A	B	C	D	E	F	G	H	
400 V	AX-RC43000020-DE	84	113	96	101	66	5	7.5	2	1.22
	AX-RC27000030-DE			105						1.60
	AX-RC14000047-DE			116						1.95
	AX-RC10100069-DE	108	135	133	120	82	6.5	9.5	-	3.70
	AX-RC06400116-DE			136						5.20
	AX-RC04410167-DE	120	152	146	135	94	7	9.5	-	6.00
	AX-RC03350219-DE			160						11.4
	AX-RC02330307-DE	150	177	182.6	160	115	7	2	-	14.3
AX-RC01750430-DE										

Output AC Reactor

Voltage	Reference	Dimensions						Weight kg
		A	B2	C2	D	E	F	
200 V	AX-RAO11500026-DE	120	70	120	80	52	5.5	1.78
	AX-RAO07600042-DE	120	70	120	80	52	5.5	1.78
	AX-RAO04100075-DE	120	80	120	80	62	5.5	2.35
	AX-RAO03000105-DE	120	80	120	80	62	5.5	2.35
	AX-RAO01830180-DE	180	85	190	140	55	6	5.5
	AX-RAO01150220-DE	180	85	190	140	55	6	5.5
	AX-RAO00950320-DE	180	85	205	140	55	6	6.5
	AX-RAO00630430-DE	180	95	205	140	65	6	9.1
400 V	AX-RAO00490640-DE	180	95	205	140	65	6	9.1
	AX-RAO16300038-DE	120	70	120	80	52	5.5	1.78
	AX-RAO11800053-DE	120	80	120	80	52	5.5	2.35
	AX-RAO07300080-DE	120	80	120	80	62	5.5	2.35
	AX-RAO04600110-DE	180	85	190	140	55	6	5.5
	AX-RAO03600160-DE	180	85	205	140	55	6	6.5
	AX-RAO02500220-DE	180	95	205	140	55	6	9.1
	AX-RAO02000320-DE	180	105	205	140	85	6	11.7

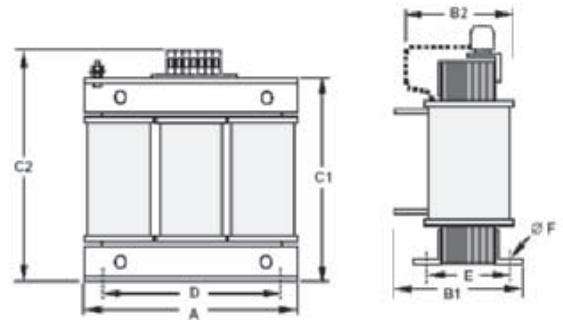

Chokes

Reference	D diameter	Motor kW	Dimensions						Weight kg
			L	W	H	X	Y	m	
AX-FER2102-RE	21	< 2.2	85	22	46	70	-	5	0.1
AX-FER2515-RE	25	< 15	105	25	62	90	-	5	0.2
AX-FER5045-RE	50	< 45	150	50	110	125	30	5	0.7

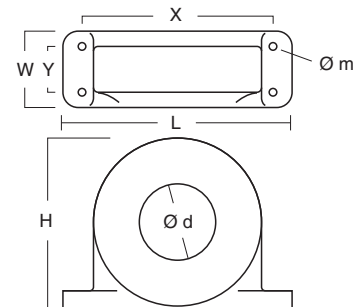

Resistor dimensions

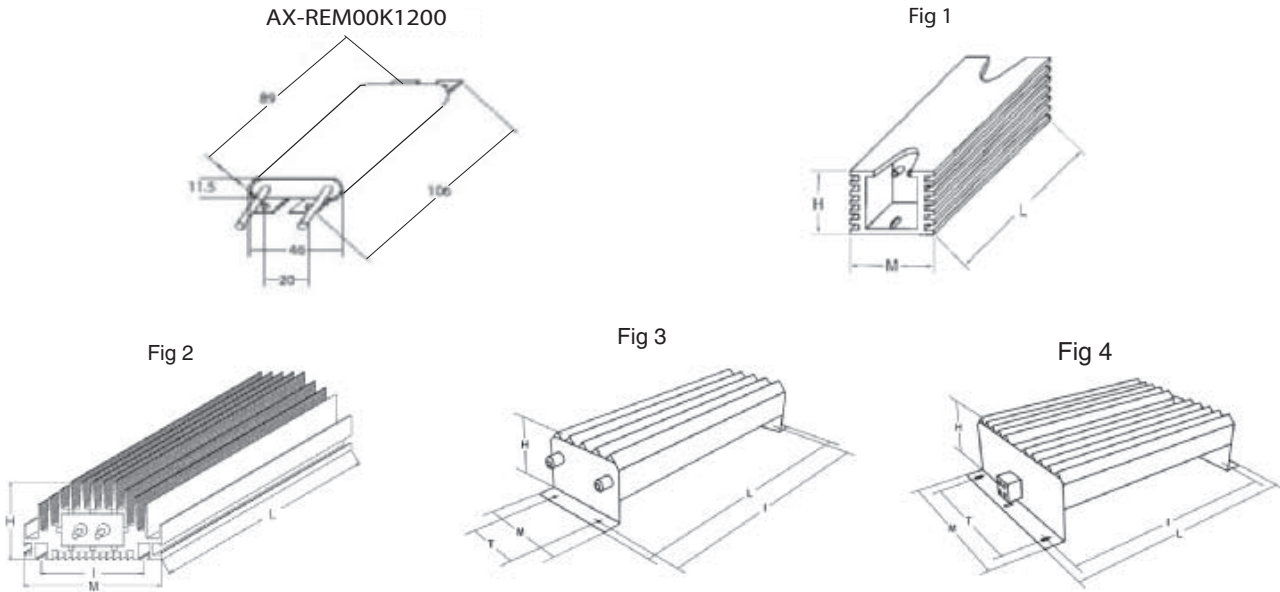

Type	Fig.	Dimensions					Weight
		L	H	M	I	T	kg
AX-REM00K1400-IE	1	105	27	36	94	-	0.2
AX-REM00K2070-IE							
AX-REM00K2120-IE							
AX-REM00K2200-IE							
AX-REM00K4075-IE							
AX-REM00K4035-IE	2	200	62	100	74	-	1.41
AX-REM00K4030-IE							
AX-REM00K5120-IE							
AX-REM00K6100-IE	3	365	73	105	350	70	4
AX-REM00K6035-IE							
AX-REM01K9070-IE	4	310	100	240	295	210	7
AX-REM01K9017-IE							
AX-REM02K1070-IE							8
AX-REM02K1017-IE							
AX-REM03K5035-IE	4	365	100	240	350	210	8
AX-REM03K5010-IE							

Standard connections

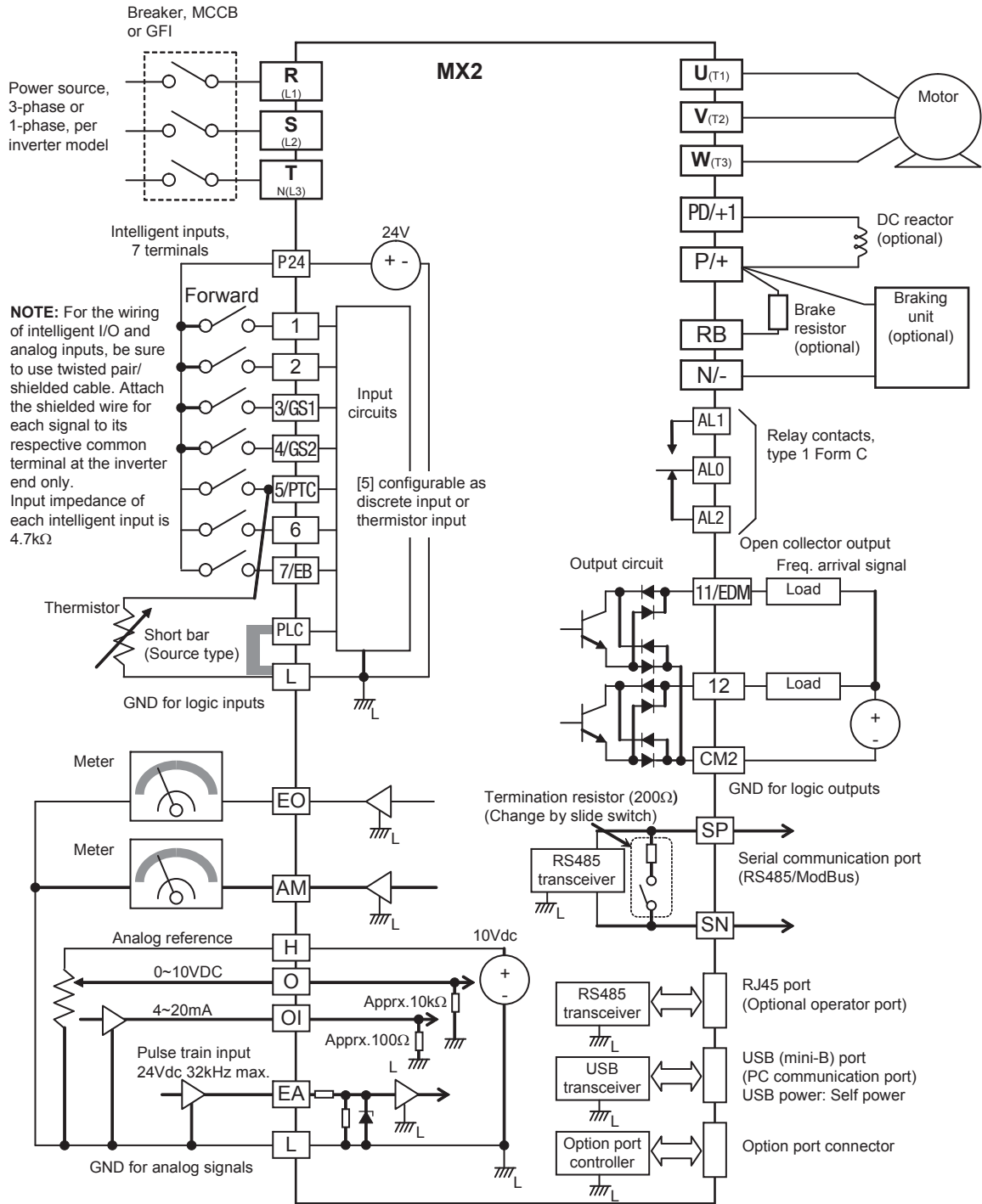

Frequency inverters

Terminal Block Specifications

Terminal	Name	Function (signal level)
R/L1, S/L2, T/L3	Main circuit power supply input	Used to connect line power to the drive. Drives with single-phase 200 V input power use only terminals R/L1 and N (T/L3), terminal S/L2 is not available for these units
U/T1, V/T2, W/T3	Inverter output	Used to connect the motor
PD/+1, P/+	External DC reactor terminal	Normally connected by the short-circuit bar. Remove the short-circuit bar between +1 and P/+2 when a DC reactor is connected.
P/+, N/-	Regenerative braking unit terminal	Connect optional regenerative braking units (If a braking torque is required)
P/+, RB	Braking resistor terminals	Connect option braking resistor (if a braking torque is required)
⊕	Grounding	For grounding (grounding should conform to the local grounding code.)

Control Circuit

Type	No.	Signal name	Function	Signal level
Digital input signals	PLC	Intelligent input common	Source type: connecting [P24] to [1]-[7] turns inputs ON Sink type: connecting [L] to [1]-[7] turns inputs ON	-
	P24	Internal 24 VDC	24 VDC, 30mA	24 VDC, 100 mA
	1	Multi-function Input selection 1	Factory setting: Forward/ Stop	27 VDC max
	2	Multi-function Input selection 2	Factory setting: Reverse/ Stop	
	3/GS1	Multi-function Input selection 3 / safe stop input 1	Factory setting: External trip	
	4/GS2	Multi-function Input selection 4 / safe stop input 2	Factory setting: Reset	
	5/PTC	Multi-function Input selection 5 / PTC thermistor input	Factory setting: Multi-step speed reference 1	
	6	Multi-function input selection 6	Factory setting: Multi-step speed reference 2	
	7/EB	Multi-function input selection 7 / Pulse train input B	Factory setting: Jog	
	L	Multi-function Input selection common (in upper row)	--	
Pulse train	EA	Pulse train input A	Factory setting: Speed reference	32 kHz max 5 to 24 VDC
	EO	Pulse train output	LAD frequency	10 VDC 2 mA 32 kHz max
Analog input signal	H	Frequency reference power supply	10 VDC 10 mA max	
	O	Voltage frequency reference signal	0 to 10 VDC (10 kΩ)	
	OI	Current frequency reference signal	4 to 20 mA (250 Ω)	
	L	Frequency reference common (bottom row)	--	
Digital output signals	11/EDM	Discrete logic output 1 / EDM output	Factory setting: During Run	27 VDC, 50 mA max EDM based on ISO13849-1
	12	Discrete logic output 2	Factory setting: Frequency arrival type 1	
	CM2	GND logic output	--	
	AL0	Relay common contact	Factory setting: Alarm signal Under normal operation AL1 - AL0 Closed AL2 - AL0 Open	R load 250 VAC 2.5 A 30 VDC 3.0 A I load 250 VAC 0.2 A 30 VDC 0.7 A
	AL1	Relay contact, normally open		
	AL2	Relay contact, normally closed		
Monitor Signal	AM	Analog voltage output	Factory setting: LAD frequency	0 to 10 VDC 1 mA
Comms	SP	Serial communication terminal	RS485 Modbus communication	
	SN			

Side by side mounting

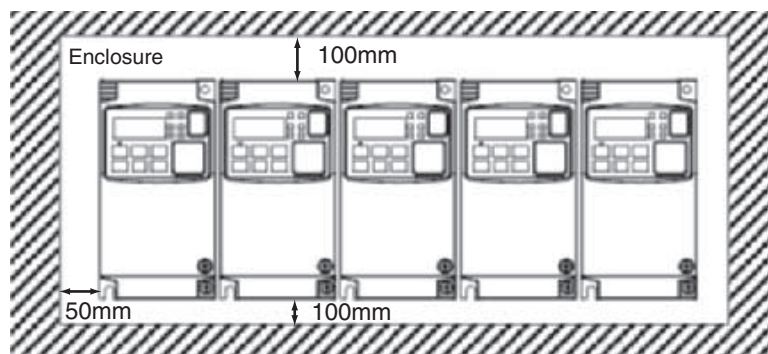

Inverter heat loss

Three-phase 200 V class

Model 3G3MX2		A2001	A2002	A2004	A2007	A2015	A2022	A2037	A2055	A2075	A2110	A2150
Inverter capacity kVA	200 VT	0.4	0.6	1.2	2.0	3.3	4.1	6.7	10.3	13.8	19.3	23.9
	200 CT	0.2	0.5	1.0	1.7	2.7	3.8	6.0	8.6	11.4	16.2	20.7
	240 VT	0.4	0.7	1.4	2.4	3.9	4.9	8.1	12.4	16.6	23.2	28.6
	240 CT	0.3	0.6	1.2	2.0	3.3	4.5	7.2	10.3	13.7	19.5	24.9
Rated current (A) VT		1.2	1.9	3.4	6.0	9.6	12.0	19.6	30.0	40.0	56.0	69.0
Rated current (A) CT		1.0	1.6	3.0	5.0	8.0	11.0	17.5	25.0	33.0	47.0	60.0
Total heat loss		12	22	30	48	79	104	154	229	313	458	625
Efficiency at rated load		89.5	90	93	94	95	95.5	96	96	96	96	96
Cooling Method		Self cooling					Forced-air-cooling					

Single-phase 200 V class

Model 3G3MX2		AB001	AB002	AB004	AB007	AB015	AB022
Inverter capacity kVA	200V VT	0.4	0.6	1.2	2.0	3.3	4.1
	200V CT	0.2	0.5	1.0	1.7	2.7	3.8
	240V VT	0.4	0.7	1.4	2.4	3.9	4.9
	240V CT	0.3	0.6	1.2	2.0	3.3	4.5
Rated current (A) VT		1.2	1.9	3.4	6.0	9.6	12.0
Rated current (A) CT		1.0	1.6	3.0	5.0	8.0	11.0
Total heat loss		12	22	30	48	79	104
Efficiency at rated load		89.5	90	93	94	95	95.5
Cooling Method		Self cooling				Forced-air-cooling	

Three-phase 400 V class

Model 3G3MX2		A4004	A4007	A4015	A4022	A4030	A4040	A4055	A4075	A4110	A4150
Inverter capacity kVA	380V VT	1.3	2.6	3.5	4.5	5.7	7.3	11.5	15.1	20.4	25.0
	380V CT	1.1	2.2	3.1	3.6	4.7	6.0	9.7	11.8	15.7	20.4
	480V VT	1.7	3.4	4.4	5.7	7.3	9.2	14.5	19.1	25.7	31.5
	480V CT	1.4	2.8	3.9	4.5	5.9	7.6	12.3	14.9	19.9	25.7
Rated current (A) VT		2.1	4.1	5.4	6.9	8.8	11.1	17.5	23.0	31.0	38.0
Rated current (A) CT		1.8	3.4	4.8	5.5	7.2	9.2	14.8	18.0	24.0	31.0
Total heat loss		35	56	96	116	125	167	229	296	411	528
Efficiency at rated load		92	93	94	95	96	96	96	96.2	96.4	96.6
Cooling Method		Self cooling				Forced-air-cooling					

Input AC Reactor

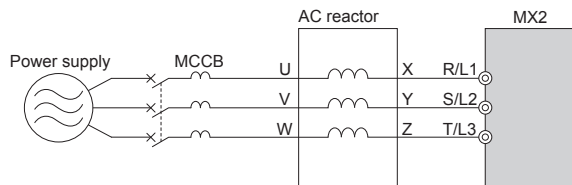

3 phase 200 V class				400 V class			
Max. applicable motor output kW	Reference	Current value A	Inductance mH	Max. applicable motor output kW	Reference	Current value A	Inductance mH
1.5	AX-RAI02800080-DE	8.0	2.8	1.5	AX-RAI07700050-DE	5.0	7.7
3.7	AX-RAI00880200-DE	20.0	0.88	4.0	AX-RAI03500100-DE	10.0	3.5
7.5	AX-RAI00350335-DE	33.5	0.35	7.5	AX-RAI01300170-DE	17.0	1.3
15	AX-RAI00180670-DE	67.0	0.18	15	AX-RAI00740335-DE	33.5	0.74

DC Reactor

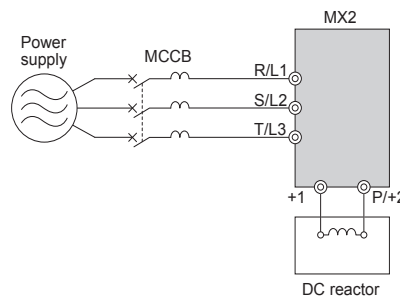

200 V class				400 V class			
Max. applicable motor output kW	Reference	Current value A	Inductance mH	Max. applicable motor output kW	Reference	Current value A	Inductance mH
0.2	AX-RC21400016-DE	1.6	21.4	0.4	AX-RC43000020-DE	2.0	43.0
0.4	AX-RC10700032-DE	3.2	10.7	0.7	AX-RC27000030-DE	3.0	27.0
0.7	AX-RC06750061-DE	6.1	6.75	1.5	AX-RC14000047-DE	4.7	14.0
1.5	AX-RC03510093-DE	9.3	3.51	2.2	AX-RC10100069-DE	6.9	10.1
2.2	AX-RC02510138-DE	13.8	2.51	3.0	AX-RC08250093-DE	9.3	8.25
3.7	AX-RC01600223-DE	22.3	1.60	4.0	AX-RC06400116-DE	11.6	6.40
5.5	AX-RC01110309-DE	30.9	1.11	5.5	AX-RC04410167-DE	16.7	4.41
7.5	AX-RC00840437-DE	43.7	0.84	7.5	AX-RC03350219-DE	21.9	3.35
11.0	AX-RC00590614-DE	61.4	0.59	11.0	AX-RC02330307-DE	30.7	2.33
15.0	AX-RC00440859-DE	85.9	0.44	15.0	AX-RC01750430-DE	43.0	1.75

Output AC Reactor

200 V class				400 V class			
Max. applicable motor output kW	Reference	Current value A	Inductance mH	Max. applicable motor output kW	Reference	Current value A	Inductance mH
0.4	AX-RAO11500026-DE	2.6	11.50	1.5	AX-RAO16300038-DE	3.8	16.30
0.75	AX-RAO07600042-DE	4.2	7.60				
1.5	AX-RAO04100075-DE	7.5	4.10				
2.2	AX-RAO03000105-DE	10.5	3.00	2.2	AX-RAO11800053-DE	5.3	11.80
3.7	AX-RAO01830160-DE	16.0	1.83	4.0	AX-RAO07300080-DE	8.0	7.30
5.5	AX-RAO01150220-DE	22.0	1.15	5.5	AX-RAO04600110-DE	11.0	4.60
7.5	AX-RAO00950320-DE	32.0	0.95	7.5	AX-RAO03600160-DE	16.0	3.60
11	AX-RAO00630430-DE	43.0	0.63	11	AX-RAO02500220-DE	22.0	2.50
15	AX-RAO00490640-DE	64.0	0.49	15	AX-RAO02000320-DE	32.0	2.00

Ordering information

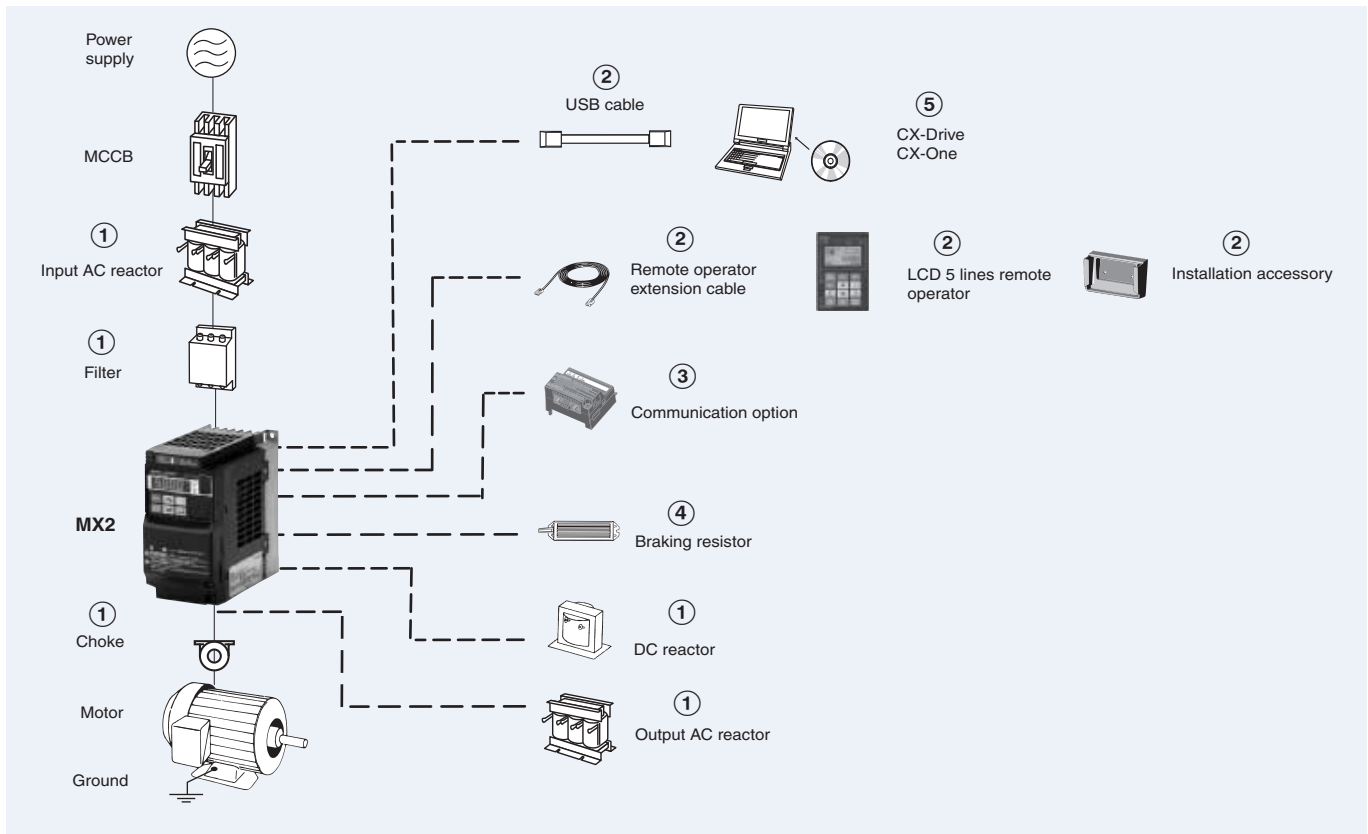

3G3MX2

Voltage class	Specifications				Model	
	Constant torque		Variable torque		IP20	IP54
	Max motor kW	Rated current A	Max motor kW	Rated current A		
Single-phase 200 V	0.1	1.0	0.2	1.2	3G3MX2-AB001-E	3G3MX2-DB001-E/EC
	0.2	1.6	0.4	1.9	3G3MX2-AB002-E	3G3MX2-DB002-E/EC
	0.4	3.0	0.55	3.5	3G3MX2-AB004-E	3G3MX2-DB004-E/EC
	0.75	5.0	1.1	6.0	3G3MX2-AB007-E	3G3MX2-DB007-EC
	1.5	8.0	2.2	9.6	3G3MX2-AB015-E	3G3MX2-DB015-EC
	2.2	11.0	3.0	12.0	3G3MX2-AB022-E	3G3MX2-DB022-EC
Three-phase 200 V	0.1	1.0	0.2	1.2	3G3MX2-A2001-E	3G3MX2-D2001-E/EC
	0.2	1.6	0.4	1.9	3G3MX2-A2002-E	3G3MX2-D2002-E/EC
	0.4	3.0	0.55	3.5	3G3MX2-A2004-E	3G3MX2-D2004-E/EC
	0.75	5.0	1.1	6.0	3G3MX2-A2007-E	3G3MX2-D2007-E/EC
	1.5	8.0	2.2	9.6	3G3MX2-A2015-E	3G3MX2-D2015-EC
	2.2	11.0	3.0	12.0	3G3MX2-A2022-E	3G3MX2-D2022-EC
	3.7	17.5	5.5	19.6	3G3MX2-A2037-E	3G3MX2-D2037-EC
	5.5	25.0	7.5	30.0	3G3MX2-A2055-E	3G3MX2-D2055-EC
	7.5	33.0	11	40.0	3G3MX2-A2075-E	3G3MX2-D2075-EC
Three-phase 400 V	0.4	1.8	0.75	2.1	3G3MX2-A4004-E	3G3MX2-D4004-EC
	0.75	3.4	1.5	4.1	3G3MX2-A4007-E	3G3MX2-D4007-EC
	1.5	4.8	2.2	5.4	3G3MX2-A4015-E	3G3MX2-D4015-EC
	2.2	5.5	3.0	6.9	3G3MX2-A4022-E	3G3MX2-D4022-EC
	3.0	7.2	4.0	8.8	3G3MX2-A4030-E	3G3MX2-D4030-EC
	4.0	9.2	5.5	11.1	3G3MX2-A4040-E	3G3MX2-D4040-EC
	5.5	14.8	7.5	17.5	3G3MX2-A4055-E	3G3MX2-D4055-EC
	7.5	18.0	11	23.0	3G3MX2-A4075-E	3G3MX2-D4075-EC
	11	24.0	15	31.0	3G3MX2-A4110-E	3G3MX2-D4110-EC
	15	31.0	18.5	38.0	3G3MX2-A4150-E	3G3MX2-D4150-EC

① Line filters

Inverter		Line filter Rasmi		Line filter Schaffner	
Voltage	Model 3G3MX2-□	Reference AX-FIM	Current (A)	Reference AX-FIM	Current (A)
1Phase 200 VAC	AB001 / AB002 / AB004	1010-RE	10	1010-SE-V1	8
	AB007	1014-RE	14	1024-SE-V1	27
	AB015 / AB022	1024-RE	24	1024-SE-V1	27
	A2001 / A2002 / A2004 / A2007	2010-RE	10	2010-SE-V1	7.8
3Phase 200 VAC	A2015 / A2022	2020-RE	20	2020-SE-V1	16
	A2037	2030-RE	30	2030-SE-V1	25
	A2055 / A2075	2060-RE	60	2060-SE-V1	50
	A2110	2080-RE	80	2080-SE-V1	75
	A2150	2100-RE	100	2100-SE-V1	100
3Phase 400 VAC	A4004 / A4007	3005-RE	5	3005-SE-V1	6
	A4015 / A4022 / A4030	3010-RE	10	3010-SE-V1	12
	A4040	3014-RE	14	3014-SE-V1	15
	A4055 / A4075	3030-RE	30	3030-SE-V1	29
	A4110 / A4150	3050-RE	50	3050-SE-V1	48

① Input AC reactors

Inverter		AC Reactor
Voltage	Model 3G3MX2-□	Reference
3-Phase 200 VAC	A2002 / A2004 / A2007	AX-RAI02800080-DE
	A2015 / A2022 / A2037	AX-RAI00880200-DE
	A2055 / A2075	AX-RAI00350335-DE
	A2110 / A2150	AX-RAI00180670-DE
1-Phase 200 VAC	AB002 / AB004	Under development
	AB007 / AB022	
3-Phase 400 VAC	A4004 / A4007 / A4015	AX-RAI07700050-DE
	A4022 / A4030 / A4040	AX-RAI03500100-DE
	A4055 / A4075	AX-RAI01300170-DE
	A4110 / A4150	AX-RAI00740335-DE

① DC reactors

200V single phase		200V 3-phase		400V 3-phase	
Inverter	DC Reactor	Inverter	DC Reactor	Inverter	DC Reactor
3G3MX2-AB001	AX-RC10700032-DE	3G3MX2-A2001	AX-RC21400016-DE	3G3MX2-A4004	AX-RC43000020-DE
3G3MX2-AB002		3G3MX2-A2002	AX-RC27000030-DE	3G3MX2-A4007	AX-RC27000030-DE
3G3MX2-AB004		3G3MX2-A2004	AX-RC10700032-DE	3G3MX2-A4015	AX-RC14000047-DE
3G3MX2-AB007		3G3MX2-A2007	AX-RC06750061-DE	3G3MX2-A4022	AX-RC10100069-DE
3G3MX2-AB015		3G3MX2-A2015	AX-RC03510093-DE	3G3MX2-A4030	AX-RC08250093-DE
3G3MX2-AB022		3G3MX2-A2022	AX-RC02510138-DE	3G3MX2-A4040	AX-RC06400116-DE
		3G3MX2-A2037	AX-RC01600223-DE	3G3MX2-A4055	AX-RC04410167-DE
		3G3MX2-A2055	AX-RC01110309-DE	3G3MX2-A4075	AX-RC03350219-DE
		3G3MX2-A2075	AX-RC00840437-DE	3G3MX2-A4011	AX-RC02330307-DE
		3G3MX2-A2011	AX-RC00590614-DE	3G3MX2-A4015	AX-RC01750430-DE
		3G3MX2-A2015	AX-RC00440859-DE		

① Chokes

Model	Diameter	Description
AX-FER2102-RE	21	For 2.2 KW motors or below
AX-FER2515-RE	25	For 15 KW motors or below
AX-FER5045-RE	50	For 45 KW motors or below

① Output AC reactor

Inverter		AC Reactor
Voltage	Model 3G3MX2-□	Reference
200 VAC	A2001 / A2002 / A2004 AB001 / AB002 / AB004	AX-RAO11500026-DE
	A2007/AB007	AX-RAO07600042-DE
	A2015 / AB015	AX-RAO04100075-DE
	A2022 / AB022	AX-RAO03000105-DE
	A2037	AX-RAO01830160-DE
	A2055	AX-RAO01150220-DE
	A2075	AX-RAO00950320-DE
	A2110	AX-RAO00630430-DE
400 VAC	A2150	AX-RAO00490640-DE
	A4004 / A4007 / A4015	AX-RAO16300038-DE
	A4022	AX-RAO11800053-DE
	A4030 / A4040	AX-RAO07300080-DE
	A4055	AX-RAO04600110-DE
	A4075	AX-RAO03600160-DE
	A4110	AX-RAO02500220-DE
A4150	AX-RAO02000320-DE	

② Accessories

Types	Model	Description	Functions	
Digital operator	AX-OP05-E	LCD remote operator	5 Line LCD remote operator with copy function, cable length max. 3m.	
	3G3AX-CAJOP300-EE	Remote operator cable		
	3G3AX-OP01	LED remote operator		3 meters cable for connecting remote operator
	4X-KITMINI	Mounting kit for LED operator		LED remote operator, cable length max. 3m
	3G3AX-OP05-H-E	Operator holder		Mounting kit for LED operator on panel
Accessories			Holder to put the AX-OP05-E inside of the cabinet	
	AX-CUSBM002-E	PC configuration cable	Mini USB to USB connector cable	

③ Communication option boards

Types	Model	Description	Functions
Communication options	3G3AX-MX2-PRT	Profibus option card	Used for running or stopping the inverter, setting or referencing parameters, and monitoring output frequency, output current, or similar items through communications with the host controller.
	3G3AX-MX2-DRT	DeviceNet option card	
	3G3AX-MX2-ECT	Ethercat option card	
	3G3AX-MX2-CRT	CompoNet option card	
	3G3AX-MX2-MRT	Mechatrolink II option card	
	3G3AX-MX2-EIP	Ethernet IP option board	

④ Braking unit, braking resistor unit

Voltage	Inverter				Braking resistor unit						
	Max. motor kW	Inverter 3G3MX2□		Connectable min. resistance Ω	Inverter mounted type (3%ED, 10 sec max)		Braking torque %	Inverter mounted type (10%ED, 10 sec max)		Braking torque %	
		3-phase	1-phase		Type AX-	Resist Ω		Type AX-	Resist Ω		
200 V (Single-/Three-phase)	0.12	2001	B001	100	REM00K1400-IE	400	200	REM00K1400-IE	400	200	
	0.25	2002	B002		180	REM00K1200-IE	200	180	REM00K1200-IE	200	180
	0.55	2004	B004		100		70	140	REM00K2070-IE	70	200
	1.1	2007	B007	50	REM00K2070-IE	70	90	REM00K4075-IE	75	130	
	1.5	2015	B015		35	REM00K4075-IE	75	50	REM00K6035-IE	35	100
	2.2	2022	B022	20		REM00K4035-IE	35	75	REM00K9020-IE	20	150
	4.0	2040	-		17			55	REM01K9017-IE	17	110
	5.5	2055	-	10		40	REM02K1017-IE	17	75		
	7.5	2075	-		35	55	REM03K5010-IE	10	95		
	11	2110	-	400 V (Three-phase)	REM00K9017-IE	17	200	REM00K1400-IE	400	200	
15	2150	-	180		REM00K1400-IE	400	200			REM00K2200-IE	200
0.55	4004	-			100	REM00K1200-IE	200	190	REM00K5120-IE		
1.1	4007	-				70	REM00K2200-IE	200		130	REM00K6100-IE
1.5	4015	-	140		REM00K2120-IE		120	160	REM00K9070-IE	70	
2.2	4022	-			100	REM00K4075-IE	75	120			REM01K9070-IE
3.0	4030	-	70					REM00K6100-IE	100	140	
4.0	4040	-			35	REM00K9070-IE	70			50	REM03K5035-IE
5.5	4055	-	100					REM00K6100-IE	100	55	
7.5	4075	-			70	REM00K9070-IE	70			50	REM03K5035-IE
11	4110	-	35	REM00K9070-IE				70	55	REM03K5035-IE	
15	4150	-			35	70	55		REM03K5035-IE		35

⑤ Computer software

Types	Model	Description	Installation
Software	CX-drive	Computer software	Configuration and monitoring software tool
	CX-One	Computer software	Configuration and monitoring software tool
	€Saver	Computer software	Software tool for Energy Saving calculation

ALL DIMENSIONS SHOWN ARE IN MILLIMETERS.
To convert millimeters into inches, multiply by 0.03937. To convert grams into ounces, multiply by 0.03527.

JX

Compact & Complete

- V/f controlled inverter
- Side by side mounting
- Built-in EMC filter
- Built-in RS-485 Modbus
- Overload detection function (150% during 60s)
- PID
- Micro-surge voltage suppression
- Automatic energy saving
- Emergency shut-off
- Second motor setting
- Auto carrier-frequency reduction
- PTC thermistor input
- Cooling fan switch control
- PC configuration tool: CX-Drive
- CE, UL, cUL, RoHS

Ratings

- 200 V Class single-phase 0.2 to 2.2 kW
- 200 V Class three-phase 0.2 to 7.5 kW
- 400 V Class three-phase 0.4 to 7.5 kW



System configuration

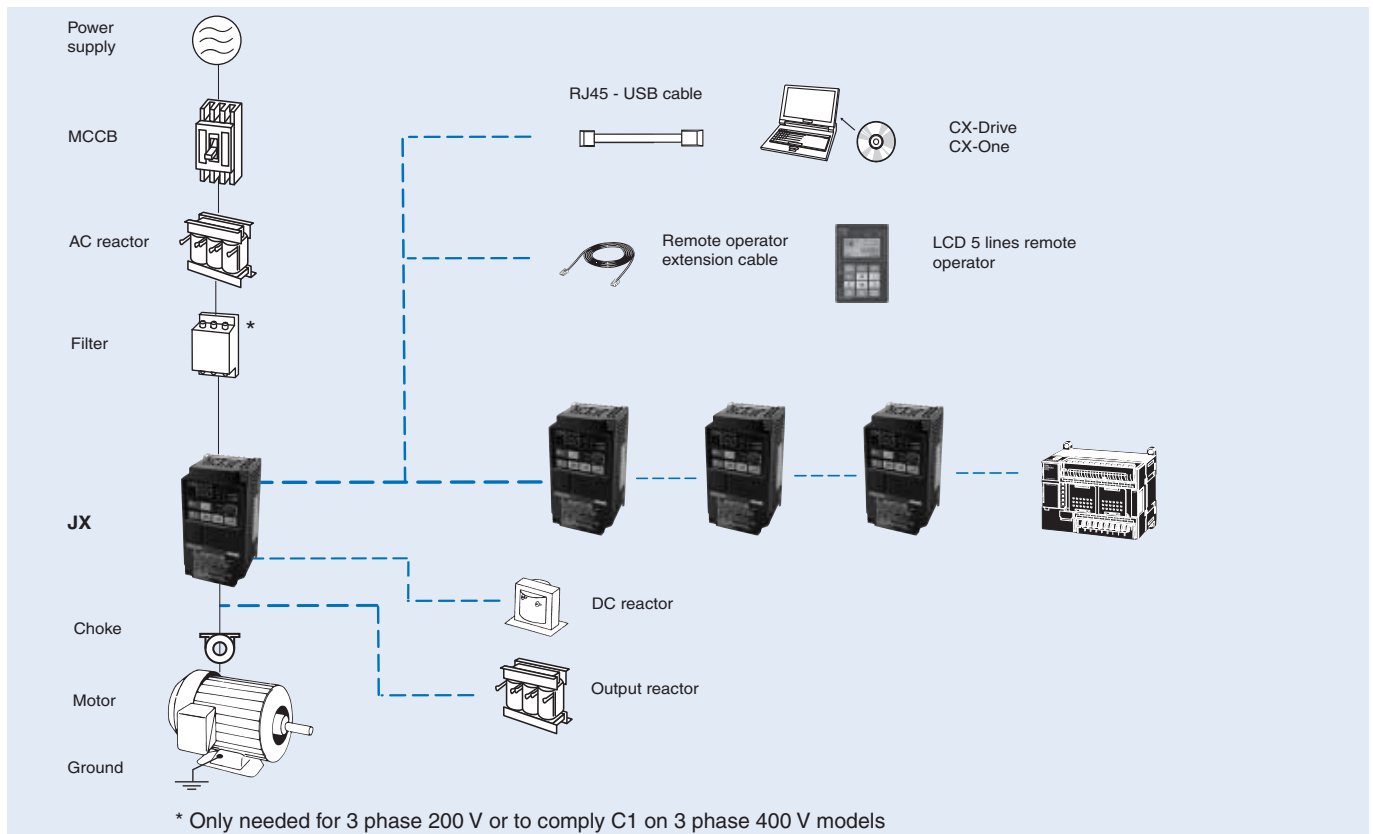

Specifications

Type designation

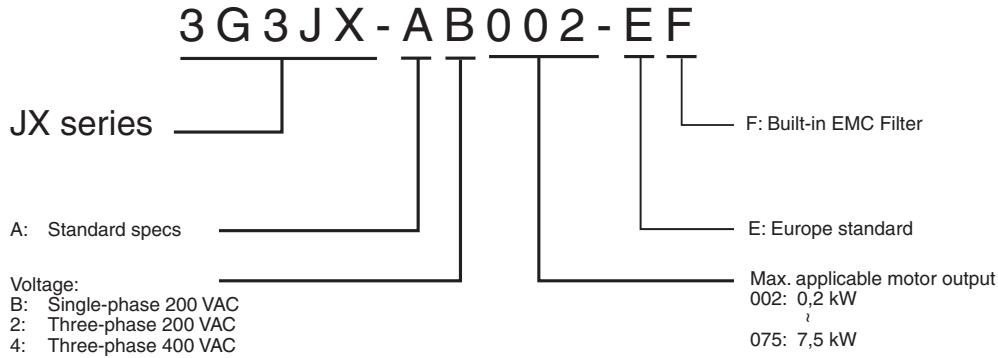

200 V class

Single-phase: 3G3JX□		AB002	AB004	AB007	AB015	AB022	-	-	-	
Three-phase: 3G3JX□		A2002	A2004	A2007	A2015	A2022	A2037	A2055	A2075	
Motor kW ^{*1}	Applicable motor capacity	0.2	0.4	0.75	1.5	2.2	3.7	5.5	7.5	
Output characteristics	Inverter capacity kVA	200 V	0.4	0.9	1.3	2.4	3.4	5.5	8.3	11.0
		240 V	0.5	1.0	1.6	2.9	4.1	6.6	9.9	13.3
	Rated output current (A)		1.4	2.6	4.0	7.1	10.0	15.9	24.0	32.0
	Max. output voltage		Proportional to input voltage: 0...240 V							
Max. output frequency		400 Hz								
Power supply	Rated input voltage and frequency		Single-phase 200...240 V 50/60 Hz 3-phase 200...240 V 50/60 Hz							
	Rated input current (A) Three-phase 200 V		1.8	3.4	5.2	9.3	13.0	20.0	30.0	40.0
	Rated input current (A) Single-phase 200 V		3.1	5.8	9.0	16.0	22.5	-	-	-
	Allowable voltage fluctuation		-15%...+10%							
	Allowable frequency fluctuation		+5%							
Built-in filter		EMC filter (C1 single phase)								
Braking torque		At short-time deceleration At capacitor feedback		Approx. 50%		50% for 3-phase 20 to 40% for 1-phase		Approx 20% to 40%		Approx 20%
Cooling method		Self cooling			Forced-air-cooling					

*1 Based on a standard 3-Phase standard motor.

400 V class

Three-phase: 3G3JX□		A4004	A4007	A4015	A4022	A4040	A4055	A4075		
Motor kW ^{*1}	Applicable motor capacity	0.4	0.75	1.5	2.2	4.0	5.5	7.5		
Output characteristics	Inverter capacity kVA	380 V	0.9	1.6	2.5	3.6	5.6	8.5	10.5	
		480 V	1.2	2.0	3.1	4.5	7.1	10.8	13.3	
	Rated output current (A)		1.5	2.5	3.8	5.5	8.6	13.0	16.0	
	Max. output voltage		Proportional to input voltage: 0...480 V							
Max. output frequency		400 Hz								
Power supply	Rated input voltage and frequency		3-phase 380...480 V 50/60 Hz							
	Rated input current (A)		2.0	3.3	5.0	7.0	11.0	16.5	20.0	
	Allowable voltage fluctuation		-15%...+10%							
	Allowable frequency fluctuation		+5%							
Built-in filter		EMC filter C2 class								
Braking torque		At short-time deceleration At capacitor feedback		Approx. 50%		Approx. 20% to 40%		Approx. 20%		
Cooling method		Self cooling			Forced-air-cooling					

*1 Based on a standard 3-Phase standard motor.

Specifications

Common specifications

Model number 3G3JX□		Specifications
Control functions	Control methods	Phase-to-phase sinusoidal modulation PWM (V/f)
	Output frequency range	0.5..400 Hz
	Frequency precision	Digital set value: ±0.01% of the max. frequency Analogue set value: ±0.4% of the max. frequency (25 ±10 °C)
	Resolution of frequency set value	Digital set value: 0.1 Hz Analogue set value: 1/1000 of maximum frequency
	Resolution of output frequency	0.1 Hz
	Overload capability	150% rated output current for one minute
	Frequency set value	0 to 10 VDC (10 kΩ), 4 to 20 mA (250 Ω), frequency setting volume (selectable), RS485 Modbus
	V/f Characteristics	Constant/ reduced torque
Functionality	Inputs signals	FW (forward), RV (reverse), CF1 to CF4 (multi-step speed), JG (jogging), DB (external DC injection braking), SET (2nd function), 2CH (2-step acceleration/deceleration), FRS (free run), EXT (external trip), USP (USP function), SFT (soft lock), AT (analog current input function selection), RS (reset), PTC (thermistor input), STA (3-wire startup), STP (3-wire stop), F/R (3-wire forward/reverse), PID (PID selection), PIDC (PID integral reset), UP (UP of UP/DWN function), DWN (DWN of UP/DWN function), UDC (data clear of UP/DWN function), OPE (forced OPE mode), ADD (frequency addition), F-TM (forced terminal block), RDY (operation ready), SP-SET (special setting), EMR (emergency shutoff)
	Output signals	RUN (signal during operation), FA1 (frequency arrival signal 1), FA2 (frequency arrival signal 2), OL (overload warning signal), OD (PID excess deviation signal), AL (alarm signal), DC (analog input disconnection detection signal), FBV (PID FB status output), NDC (network error), LOG (logical operation result), ODc (communication option disconnected), LOC (light load signal)
	Standard functions	AVR function, V/f characteristic selection, upper/lower limit, 16-step speeds, starting frequency adjustment, jogging operation, carrier frequency adjustment, PID control, frequency jump, analog gain/bias adjustment, S-shape acceleration/deceleration, electronic thermal characteristics/level adjustment, retry function, simplified torque boost, trip monitor, soft lock function, frequency conversion display, USP function, 2nd control function, motor rotation speed UP/DOWN, overcurrent suppression function
	Analogue inputs	2 analogue inputs 0 to 10 V (20 kΩ), 4 to 20 mA (250 Ω)
	Accel/Decel times	0.01 to 3000 s (line/curve selection), 2nd accel/decel setting available
	Display	Status indicator LED's Run, Program, Power, Alarm, Power, Hz, Amps, Volume Led indicator Digital operator: Available to monitor frequency reference, output current, output frequency
	Motor overload protection	Electronic Thermal overload relay and PTC thermistor input
Protection functions	Instantaneous overcurrent	180% of rated current
	Overload	150% for 1 minute
	Overvoltage	790 V for 400 V type and 395 for 200 V type
	Momentary power loss	Following items are selectable: Alarm, 0 Hz start, frequency output at interruption, maximum frequency
	Cooling fin overheat	Temperature monitor and error detection
	Stall prevention level	Selectable level applicable only at constant speed or during acceleration and constant speed
	Ground fault	Detected at power-on
	Power charge indication	On when power is supplied to the control part
Ambient conditions	Degree of protection	IP20
	Ambient humidity	90% RH or less (without condensation)
	Storage temperature	-20°C..+65 °C (short-term temperature during transportation)
	Ambient temperature	-10°C to 50°C (Both the carrier frequency and output current need to be reduced at over 40°C.)
	Installation	Indoor (no corrosive gas, dust, etc.)
	Installation height	Max. 1000 m
Vibration	5.9 m/s ² (0.6 G), 10 to 55 Hz (Complies with the test method specified in JIS C0040 (1999).)	

Dimensions

IP 20 type 0.2 to 7.5 kW

Figure 1

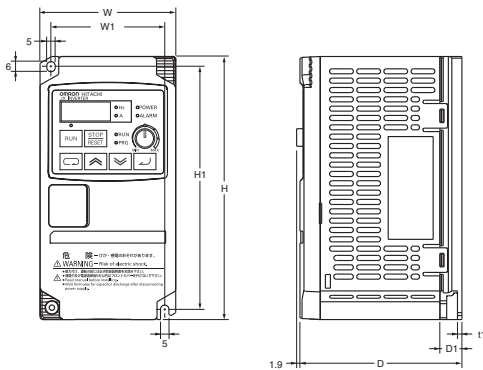
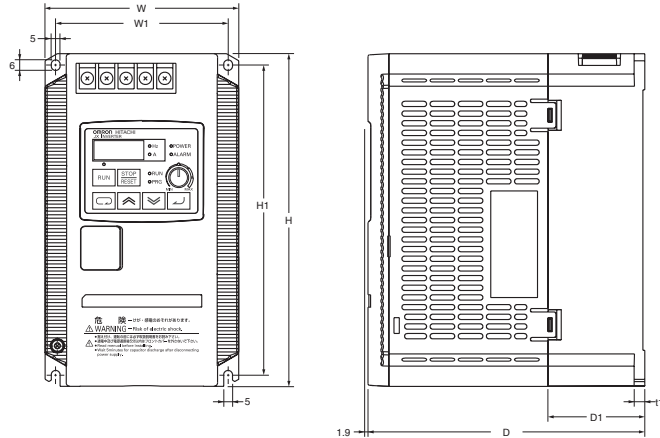

Figure 2



Voltage class	Max. applicable motor output kW	Inverter model 3G3JX□	Figure	Dimensions in mm								
				W1	H1	W	H	D	t1	D1	Weight	
Single-phase 200 V	0.2	AB002	1	67	143	80	155	95.5	2.6	13	0.8	
	0.4	AB004	1					109.5		27	0.9	
	0.75	AB007	2					130.5		28	1.5	
	1.5	AB015	2	98	176	110	189	157.5	6	55	2.3	
	2.2	AB022	2								2.4	
Three-phase 200 V	0.2	A2002	1	67	143	80	155	95.5	2.6	13	0.8	
	0.4	A2004	1					109.5		27	0.9	
	0.75	A2007	1					132.5		50	1.1	
	1.5	A2015	2	98	176	110	189	157.5	6	55	2.2	
	2.2	A2022	2								2.4	
	3.7	A2037	2	164	235	180	250	167.5	1.6	77.5	4.2	
5.5	A2055	2										
7.5	A2075	2										
Three-phase 400 V	0.4	A4004	2	98	176	110	189	130.5	2.6	28	1.5	
	0.75	A4007	2					157.5		6	55	2.3
	1.5	A4015	2					157.5				2.4
	2.2	A4022	2	164	235	180	250	167.5	1.6	77.5	4.2	
	4.0	A4040	2									
	5.5	A4055	2									
7.5	A4075	2										

Rasmi footprint Filters

Filter only needed by the 1-phase 200 V or 3-phase 400 V to comply with C1 EMC class.

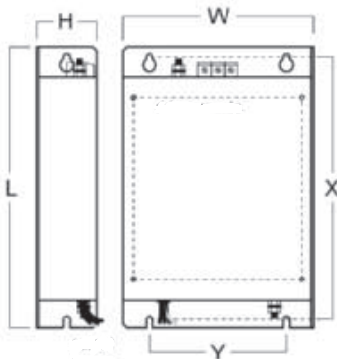

Rasmi model	Dimensions						Weight kg	
	W	H	L	X	Y	M		
1x200 V	AX-FIJ1006-RE	81	40	193	183	57	M4	0.5
	AX-FIJ1010-RE	112	47	226	216	88	M4	0.6
	AX-FIJ1026-RE	112	47	226	216	88	M4	0.8
3x200 V	AX-FIJ2006-RE	81	50	193	183	57	M4	1.0
	AX-FIJ2020-RE	112	50	226	216	88	M4	1.3
	AX-FIJ2040-RE	182	55	289	279	150	M5	2.3
3x400 V	AX-FIJ3005-RE	112	45	226	216	88	M4	0.9
	AX-FIJ3011-RE	112	45	226	216	88	M4	1.1
	AX-FIJ3020-RE	182	45	289	279	150	M4	1.7

Input AC Reactor

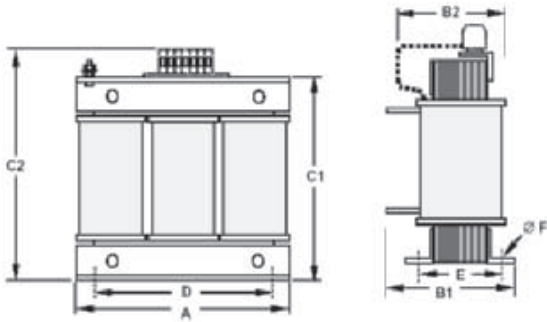

Voltage	Reference	Dimensions						Weight kg
		A	B2	C2	D	E	F	
200 V	AX-RAI02800080-DE	120	70	120	80	52	5.5	1.78
	AX-RAI00880175-DE	120	80	120	80	62	5.5	2.35
	AX-RAI00350335-DE	180	85	190	140	55	6	5.5
400 V	AX-RAI07700042-DE	120	70	120	80	52	5.5	1.78
	AX-RAI03500090-DE	120	80	120	80	62	5.5	2.35
	AX-RAI01300170-DE	120	80	120	80	62	5.5	2.50

DC Reactor

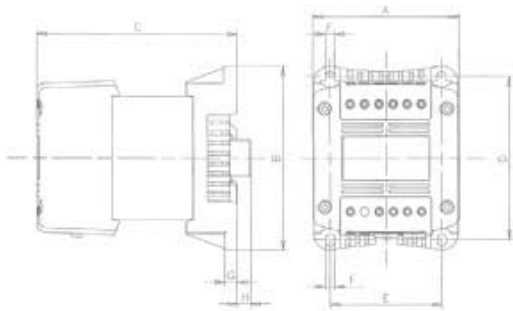

Voltage	Reference	Dimensions								Weight kg
		A	B	C	D	E	F	G	H	
200 V	AX-RC21400016-DE			96						1.22
	AX-RC10700032-DE									
	AX-RC06750061-DE	84	113	105	101	66	5	7.5	2	1.60
	AX-RC03510093-DE			116						1.95
	AX-RC02510138-DE									
	AX-RC01600223-DE	108	135	124	120	82	6.5		9.5	3.20
	AX-RC01110309-DE			136				9.5		5.20
400 V	AX-RC00840437-DE	120	152	146	135	94	7		-	6.00
	AX-RC43000020-DE			96						1.22
	AX-RC27000030-DE	84	113	105	101	66	5	7.5	2	1.60
	AX-RC14000047-DE			116						1.95
	AX-RC10100069-DE									
	AX-RC06400116-DE	108	135	133	120	82	6.5		9.5	3.70
	AX-RC04410167-DE			136				9.5		5.20
AX-RC03350219-DE	120	152	146	135	94	7		-	6.00	

Output AC Reactor

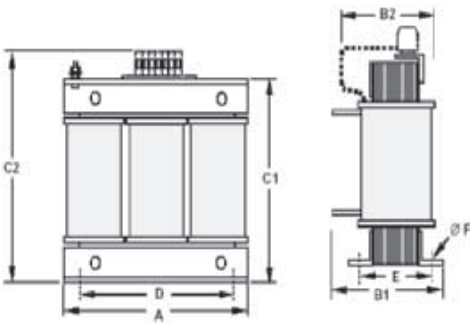

Voltage	Reference	Dimensions						Weight kg
		A	B2	C2	D	E	F	
200 V	AX-RAO11500026-DE	120	70	120	80	52	5.5	1.78
	AX-RAO07600042-DE	120	70	120	80	52	5.5	1.78
	AX-RAO04100075-DE	120	80	120	80	62	5.5	2.35
	AX-RAO03000105-DE	120	80	120	80	62	5.5	2.35
	AX-RAO01830180-DE	180	85	190	140	55	6	5.5
	AX-RAO01150220-DE	180	85	190	140	55	6	5.5
	AX-RAO00950320-DE	180	85	205	140	55	6	6.5
400 V	AX-RAO16300038-DE	120	70	120	80	52	5.5	1.78
	AX-RAO11800053-DE	120	80	120	80	52	5.5	2.35
	AX-RAO07300080-DE	120	80	120	80	62	5.5	2.35
	AX-RAO04600110-DE	180	85	190	140	55	6	5.5
	AX-RAO03600160-DE	180	85	205	140	55	6	6.5

Chokes

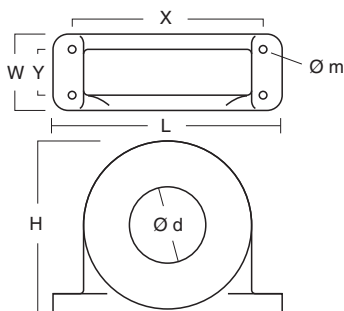

Reference	D diameter	Motor KW	Dimensions						Weight kg
			L	W	H	X	Y	m	
AX-FER2102-RE	21	< 2.2	85	22	46	70	-	5	0.1
AX-FER2515-RE	25	< 15	105	25	62	90	-	5	0.2

Installation

Standard connections

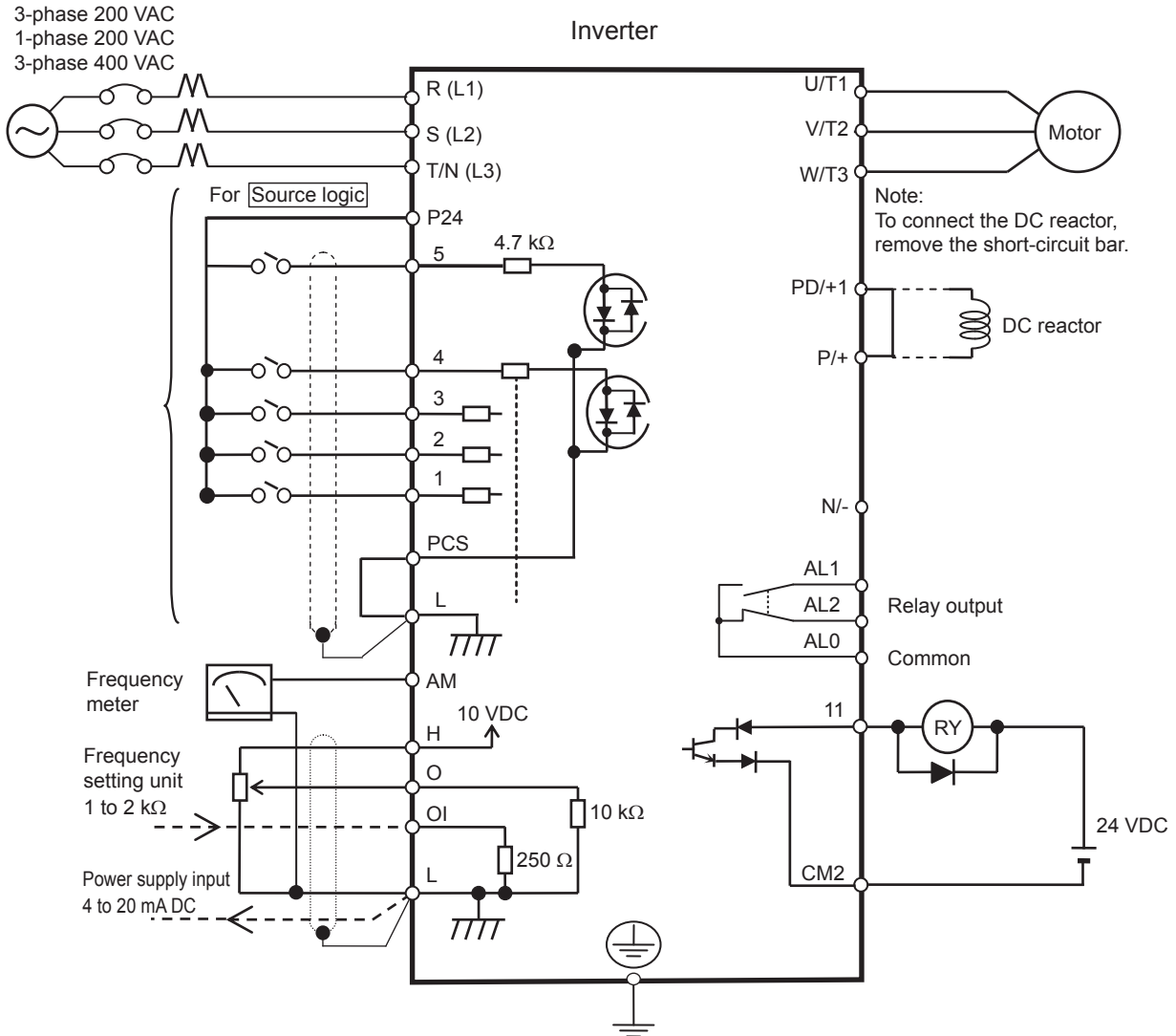

Terminal Block Specifications

Terminal	Name	Function (signal level)
R/L1, S/L2, T/N/L3	Main circuit power supply input	Used to connect line power to the drive. Drives with single-phase 200 V input power use only terminals R/L1 and N (T/L3), terminal S/L2 is not available for these units
U/T1, V/T2, W/T3	Inverter output	Used to connect the motor
PD/+1, P/+	External DC reactor terminal	Normally connected by the short-circuit bar. Remove the short-circuit bar between +1 and P/+2 when a DC reactor is connected.
P/+, N/-	Regenerative braking unit connection terminal	Connect optional regenerative braking units (If a braking torque is required)
⊕	Grounding	For grounding (grounding should conform to the local grounding code.)

Control Circuit

Type	No.	Signal name	Function	Signal level
Digital input signals	PCS	Input power supply	External power supply terminal for input signal (input) ...At sink logic Internal power supply output terminal for input signal (output) ...At source logic	24 VDC ±10%
	P24	Internal 24 VDC	24 VDC internal power supply	24 VDC±10% 100 mA
	1	Multi-function Input selection 1	Factory setting: Forward/ Stop	
	2	Multi-function Input selection 2	Factory setting: Reverse/ Stop	
	3	Multi-function Input selection 3	Factory setting: Fault reset	
	4	Multi-function Input selection 4	Factory setting: Emergency stop fault	
	5	Multi-function Input selection 5	Factory setting: Multi-step speed reference 1	
L	Multi-function Input selection common	--	--	
Analog input signal	H	Frequency reference power supply	10 VDC 10 mA max	
	O	Voltage frequency reference signal	0 to 10 VDC (10 KΩ)	
	OI	Current frequency reference signal	4 to 20 mA (250 Ω)	
	L	Frequency reference common	--	
Digital output signals	AL2	NC output	Factory default relay settings Under normal operation: AL2-AL0 Closed Under abnormal operation or power shutdown: AL1-AL0 Open	250 VAC 2.5 A 30 VDC 3 A
	AL1	NO output		250 VAC 1 A 30 VDC 1 A
	AL0	Relay Output common		
	11	Multi-function output terminal	Factory setting: Frequency arrival signal at a constant speed	27 VDC 50 mA max
	CM2	Output signal common	--	
Monitor Signal	AM	Analog frequency monitor/Analog output current monitor	Factory setting: Analog frequency monitor	0 to 10 VDC 1 mA

Frequency inverters

Side by side mounting

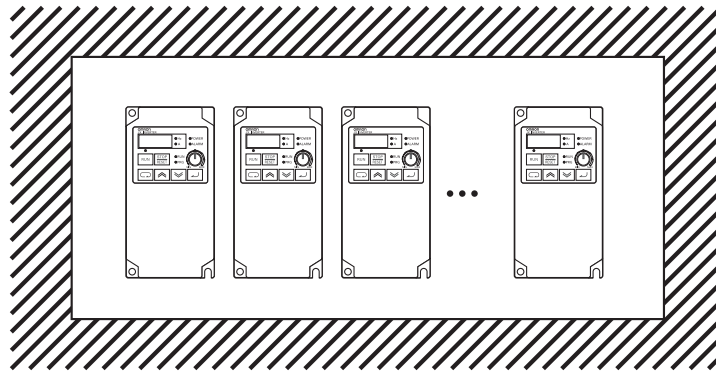

Input AC Reactor

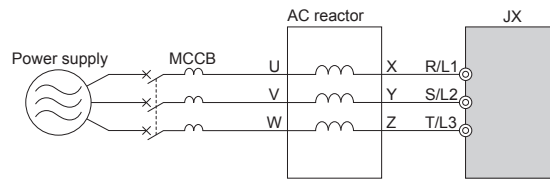

3 phase 200 V class				400 V class			
Max. applicable motor output kW	Reference	Current value A	Inductance mH	Max. applicable motor output kW	Reference	Current value A	Inductance mH
0.1 to 1.5	AX-RAI02800080-DE	8.0	2.8	0.4 to 1.5	AX-RAI07700042-DE	4.2	7.7
2.2 to 3.7	AX-RAI00880175-DE	17.5	0.88	2.2 to 4.0	AX-RAI03500090-DE	9.0	3.5
5.5 to 7.5	AX-RAI00350335-DE	33.5	0.35	5.5 to 7.5	AX-RAI01300170-DE	17.0	1.3

DC Reactor

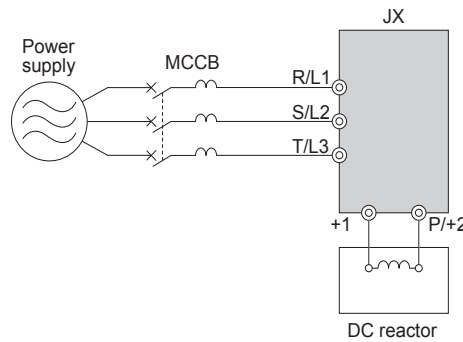

200 V class				400 V class			
Max. applicable motor output kW	Reference	Current value A	Inductance mH	Max. applicable motor output kW	Reference	Current value A	Inductance mH
0.2	AX-RC21400016-DE	1.6	21.4	-	-	-	-
0.4	AX-RC10700032-DE	3.2	10.7	0.4	AX-RC43000020-DE	2.0	43.0
0.7	AX-RC06750061-DE	6.1	6.75	0.7	AX-RC27000030-DE	3.0	27.0
1.5	AX-RC03510093-DE	9.3	3.51	1.5	AX-RC14000047-DE	4.7	14.0
2.2	AX-RC02510138-DE	13.8	2.51	2.2	AX-RC10100069-DE	6.9	10.1
3.7	AX-RC01600223-DE	22.3	1.60	4.0	AX-RC06400116-DE	11.6	6.40
5.5	AX-RC01110309-DE	30.9	1.11	5.5	AX-RC04410167-DE	16.7	4.41
7.5	AX-RC00840437-DE	43.7	0.84	7.5	AX-RC03350219-DE	21.9	3.35

Output AC Reactor

200 V class				400 V class			
Max. applicable motor output kW	Reference	Current value A	Inductance mH	Max. applicable motor output kW	Reference	Current value A	Inductance mH
0.1 to 0.4	AX-RAO11500026-DE	2.6	11.50	0.4 to 1.5	AX-RAO16300038-DE	3.8	16.30
0.75	AX-RAO07600042-DE	4.2	7.60	2.2	AX-RAO11800053-DE	5.3	11.80
1.5	AX-RAO04100075-DE	7.5	4.10	4.0	AX-RAO07300080-DE	8.0	7.30
2.2	AX-RAO03000105-DE	10.5	3.00	5.5	AX-RAO04600110-DE	11.0	4.60
3.7	AX-RAO01830160-DE	16.0	1.83	7.5	AX-RAO03600160-DE	16.0	3.60
5.5	AX-RAO01150220-DE	22.0	1.15	-	-	-	-
7.5	AX-RAO00950320-DE	32.0	0.95	-	-	-	-

Ordering information

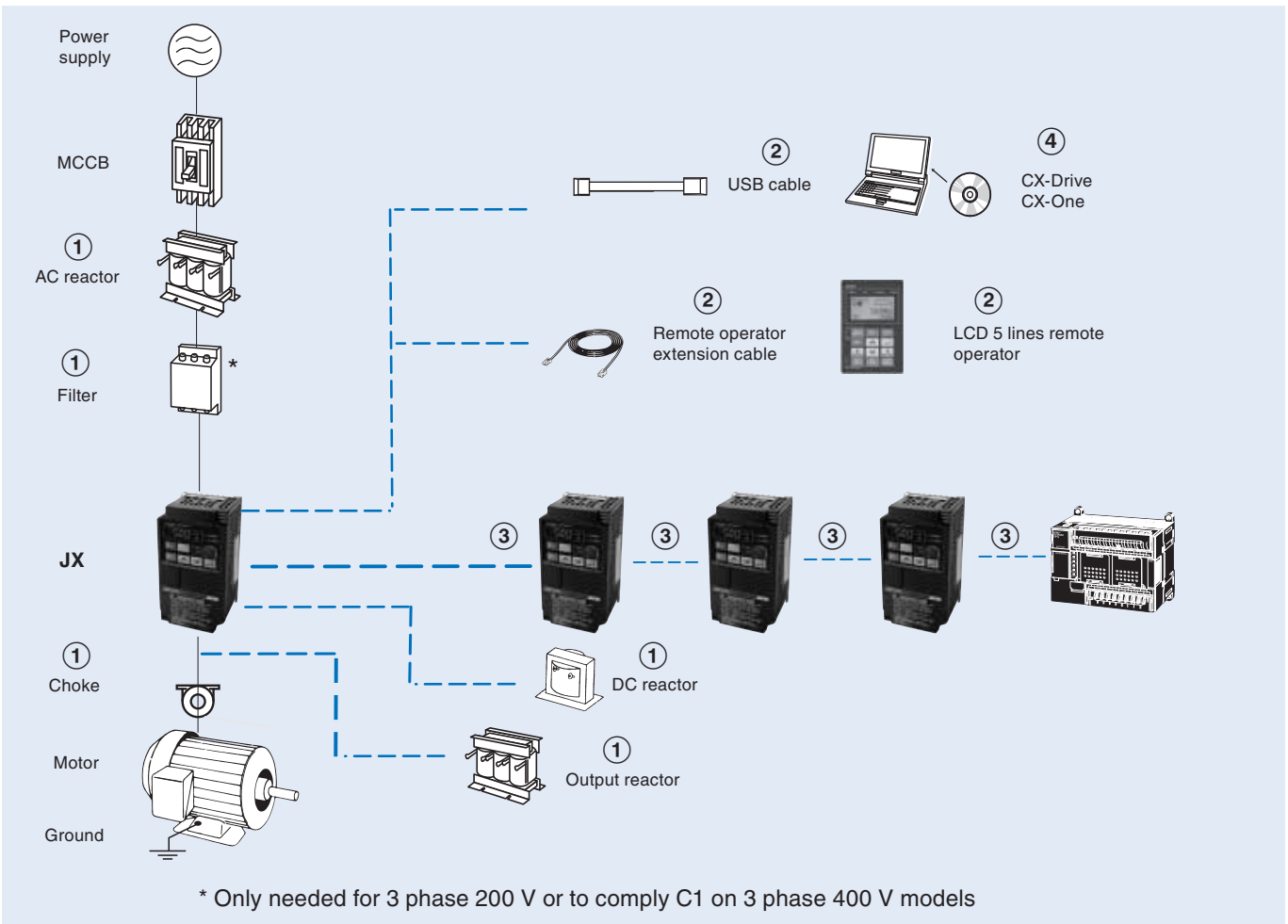

Frequency inverters

3G3JX

Voltage class	Specifications		Model
	Max. applicable motor output kW	Rated output current (A)	Standard
Single-phase 200 V	0.2	1.4	3G3JX-AB002-EF
	0.4	2.6	3G3JX-AB004-EF
	0.75	4	3G3JX-AB007-EF
	1.5	7.1	3G3JX-AB015-EF
	2.2	10	3G3JX-AB022-EF
Three-phase 200 V	0.2	1.4	3G3JX-A2002-E
	0.4	2.6	3G3JX-A2004-E
	0.75	4	3G3JX-A2007-E
	1.5	7.1	3G3JX-A2015-E
	2.2	10	3G3JX-A2022-E
	3.7	15.9	3G3JX-A2037-E
	5.5	24	3G3JX-A2055-E
Three-phase 400 V	7.5	32	3G3JX-A2075-E
	0.4	1.5	3G3JX-A4004-EF
	0.75	2.5	3G3JX-A4007-EF
	1.5	3.8	3G3JX-A4015-EF
	2.2	5.5	3G3JX-A4022-EF
	4.0	8.6	3G3JX-A4040-EF
	5.5	13	3G3JXA4055-EF
7.5	16	3G3JXA4075-EF	

① Line filters

Inverter		Line filter Rasmi		
Voltage	Model 3G3JX-□	Reference	Rated current (A)	Weight (kg)
1-Phase 200 VAC	AB002 / AB004	AX-FIJ1006-RE	6	0.5
	AB007	AX-FIJ1010-RE	10	0.6
	AB015 / AB022	AX-FIJ1026-RE	26	0.8
3-Phase 200 VAC	A2002 / A2004 / A2007	AX-FIJ2006-RE	6	1.0
	A2015 / A2022 / A2037	AX-FIJ2020-RE	20	1.3
	A2055 / A2075	AX-FIJ2040-RE	40	2.3
3-Phase 400 VAC	A4004 / A4007 / A4015	AX-FIJ3005-RE	5	0.9
	A4022 / A4040	AX-FIJ3011-RE	11	1.1
	A4055 / A4075	AX-FIJ3020-RE	20	1.7

① Input AC Reactors

Inverter		AC Reactor
Voltage	Model 3G3JX-□	Reference
3-Phase 200 VAC	A2002 / A2004 / A2007	AX-RAI02800080-DE
	A2015 / A2022 / A2037	AX-RAI00880175-DE
	A2055 / A2075	AX-RAI00350335-DE
1-Phase 200 VAC	AB002 / AB004	Under development
	AB007	
	AB015 / AB022	
3-Phase 400 VAC	A4004 / A4007 / A4015	AX-RAI07700042-DE
	A4022 / A4040	AX-RAI03500090-DE
	A4055 / A4075	AX-RAI01300170-DE

① DC Reactors

200V single phase		200V 3-phase		400V 3-phase	
Inverter	DC Reactor	Inverter	DC Reactor	Inverter	DC Reactor
3G3JX-AB002	AX-RC10700032-DE	3G3JX-A2002	AX-RC21400016-DE	-	-
3G3JX-AB004	AX-RC06750061-DE	3G3JX-A2004	AX-RC10700032-DE	3G3JX-A4004	AX-RC43000020-DE
3G3JX-AB007	AX-RC03510093-DE	3G3JX-A2007	AX-RC06750061-DE	3G3JX-A4007	AX-RC27000030-DE
3G3JX-AB015	AX-RC02510138-DE	3G3JX-A2015	AX-RC03510093-DE	3G3JX-A4015	AX-RC14000047-DE
3G3JX-AB022	AX-RC01600223-DE	3G3JX-A2022	AX-RC02510138-DE	3G3JX-A4022	AX-RC10100069-DE
-	-	3G3JX-A2037	AX-RC01600223-DE	3G3JX-A4040	AX-RC06400116-DE
-	-	3G3JX-A2055	AX-RC01110309-DE	3G3JX-A4055	AX-RC04410167-DE
-	-	3G3JX-A2075	AX-RC00840437-DE	3G3JX-A4075	AX-RC03350219-DE

① Chokes

Model	Diameter	Description
AX-FER2102-RE	21	For 2.2 KW motors or below
AX-FER2515-RE	25	For 7.5 KW motors or below

① Output AC Reactors

Inverter		AC Reactor
Voltage	Model 3G3JX-□	Reference
200 VAC	A2001 / A2002 / A2004 AB001 / AB002 / AB004	AX-RAO11500026-DE
	A2007/AB007	AX-RAO07600042-DE
	A2015 / AB015	AX-RAO04100075-DE
	A2022 / AB022	AX-RAO03000105-DE
	A2037	AX-RAO01830160-DE
	A2055	AX-RAO01150220-DE
	A2075	AX-RAO00950320-DE
400 VAC	A4004 / A4007 / A4015	AX-RAO16300038-DE
	A4022	AX-RAO11800053-DE
	A4040	AX-RAO07300080-DE
	A4055	AX-RAO04600110-DE
	A4075	AX-RAO03600160-DE

② Accessories

Types	Model	Description	Functions
Digital operator	AX-OP05-E	LCD remote operator	5 Line LCD remote operator with copy function, cable length max. 3m. *1
	3G3AX-CAJOP300-EE	Remote operator cable	3 meters cable for connecting remote operator
	3G3AX-OP01	LED remote operator	LED remote operator, cable length max. 3m
	4X-KITMINI	Mounting kit for LED operator	Mounting kit for LED operator on panel
Accessories	3G3AX-PCACN2 USB-convertercable	USB converter / USB cable	RJ45 to USB connection cable
	3G3AX-CTB020-EE	RJ45 T-Branch cable	T cable for RS-422 connection
	3G3AX-CTR150-EE	RJ45 Terminator resistor	Terminator resistor for RS-422 connection

*1 Please note, for 3G3JX inverters models, the operator will only display 2 lines of text.

④ Computer software

Types	Model	Description	Installation
Software	CX-Drive	Computer software	Configuration and monitoring software tool
	CX-One	Computer software	Configuration and monitoring software tool
	€Saver	Computer software	Software tool for Energy Saving calculation

ALL DIMENSIONS SHOWN ARE IN MILLIMETERS.
To convert millimeters into inches, multiply by 0.03937. To convert grams into ounces, multiply by 0.03527.

SX (400V)

High performance Vector Control

- IP54 full range.
- Compact design & Robustness
- Built-in Filter according to C3 Class
- Built-in Fuses (From 200 kW)
- Safety according EN13849-1 and EN62061 standards
- Load curve control
- HCB technology (Half controlling Bridge)
- Logic programmability
- Pre-maintenance alarms
- Options flexibility (I/O's, Fieldbus, PTC/PT100, Multiple Pump control, Encoder, Crane control)
- Communications options (Modbus, Dnet, Profibus)
- 24 VDC control board supply
- Liquid cooling drive version
- 12-pulse rectifier option.
- Flexible cable connections & User Friendly wiring connection
- CE, UL, RoHS, DNV

Ratings

- 400 V Class three-phase 0.75 to 800 kW



System configuration

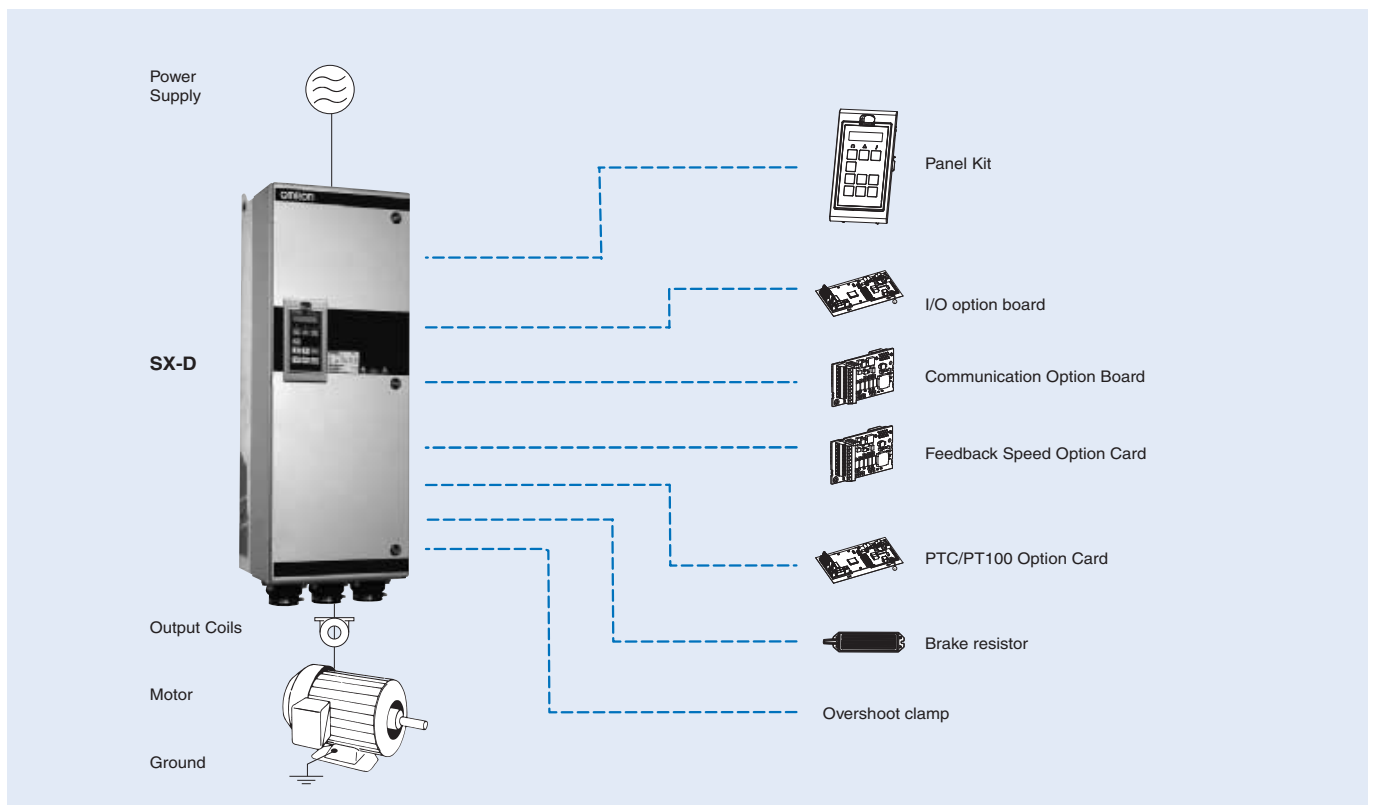

Specifications

Type designation

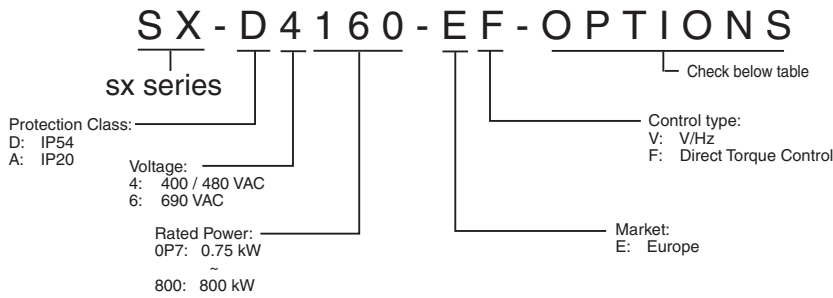

Options available

Options	Letter ("?" means no character)	Options	Letter ("?" means no character)
Control panel	"?" = Standard control panel (Std.PPU) "A" = Blank control panel (Blank PPU)	Option board position 3	"?" = No option "I" = Encoder "J" = PTC/PT100 "K" = Extended I/O"
Built-in EMC filter	"?" = Standard EMC inside (Category C3) "B" = IT-Net (filter disconnected from ground)	Option board Fieldbus position 4	"?" = No option "L" = DeviceNet "M" = Profibus-DP "N" = RS232/485 "O" = EtherNet Modbus TCP
Built-in brake chopper	"?" = No brake chopper or DC-connection included "C" = Brake chopper & DC-connection included "D" = Only DC-connection included	Liquid Cooling	"?" = No Liquid Cooling "P" = Liquid Cooling
Standby power supply	"?" = Not included "E" = Standby power supply included	Standard	"?" = IEC "Q" = UL
Safe stop	"?" = Not included "F" = Safe stop included	Marine	"?" = No marine option "R" = Marine option included
Coated boards	"?" = No coating "G" = Coated boards	Cabinet input options	"?" = No cabinet input options "S" = Main switch included "T" = Main contactor included "U" = Main switch + contactor included
Option board position 1	"?" = No option "H" = Crane I/O "I" = Encoder "J" = PTC/PT100 "K" = Extended I/O"	Cabinet output options	"?" = No cabinet output options included "V" = dV/dt filter included "W" = dV/dt filter + Overshoot clamp included "X" = Sinusfilter included
Option board position 2	"?" = No option "I" = Encoder "J" = PTC/PT100 "K" = Extended I/O"	additional options	"Z1" = Common mode output filter "Z2" = Cable gland kit "Z3" = Motor PTC connection Only models from 0.37 to 37KW

400 V class

Three-phase: SX-□4□□□-E□		0P7	1P5	2P2	3P0	4P0	5P5	7P5	011	015	018	022	030	037	045	055	
Motor kW ¹	For HD setting	0.55	1.1	1.5	2.2	3	4	5.5	7.5	11	15	18.5	22	30	37	45	
	For ND setting	0.75	1.5	2.2	3	4	5.5	7.5	11	15	18.5	22	30	37	45	55	
Output characteristics	Max output current (A) □-EF	3.8	6.0	9.0	11.3	14.3	19.5	27.0	39.0	46.0	55.0	69.0	92.0	111	108	131	
	Max output current (A) □-EV	3.0	4.8	7.2	9.0	11.4	15.6	21.6	31.0	37.0	44.0	55.0	73.0	89.0	108	131	
	Rated output current (A) at HD	2.0	3.2	4.8	6.0	7.6	10.4	14.4	21.0	25.0	29.6	37.0	49.0	59.0	72.0	87.0	
	Rated output current (A) at ND	2.5	4.0	6.0	7.5	9.5	13.0	18.0	26.0	31.0	37.0	46.0	61.0	74.0	90.0	109	
	Output voltage	0 to Mains supply voltage															
Power supply	Max. output frequency	400 Hz															
	Rated input voltage and frequency	3-phase 230..480 V 50/60 Hz															
	Allowable voltage fluctuation	+10%...-15% (-10% at 230V)															
Allowable frequency fluctuation	45 to 65 Hz																

1. Based on a standard 4-pole motor for maximum applicable motor output

400 V class

Three-phase: SX-□4□□□-E□		075	090	110	132	160	200	220	250	315	355	400	450	500	630	800	
Motor kW	For HD setting	55	75	90	110	132	160	200	220	250	315	355	400	450	500	630	
	For ND setting	75	90	110	132	160	200	220	250	315	355	400	450	500	630	800	
Output characteristics	Max output current (A) □-EF	175	210	252	300	360	450	516	600	720	780	900	1032	1200	1440	1800	
	Max output current (A) □-EV	175	210	252	300	360	450	516	600	720	780	900	1032	1200	1440	1800	
	Rated output current (A) at HD	117	140	168	200	240	300	344	400	480	520	600	688	800	960	1200	
	Rated output current (A) at ND	146	175	210	250	300	375	430	500	600	650	750	860	1000	1200	1500	
	Output voltage	0 to Mains supply voltage															
Power supply	Max. output frequency	400 Hz															
	Rated input voltage and frequency	3-phase 230..480 V 50/60 Hz															
	Allowable voltage fluctuation	+10%...-15% (-10% at 230V)															
Allowable frequency fluctuation	45 to 65 Hz																

Specifications

Common specifications

Model number SX-	Specifications	
Control functions	Control methods	V/f control for "V" type V/f control, Vector control with or without feedback for the "F" type
	Output frequency range	0.0..400 Hz
	Frequency tolerance	Analogue set value: 1% + 1.5 LSB fsd
	Resolution of frequency set value	Digital set value: 0.1 Hz Analogue set value: 0.03 Hz / 60 Hz (11 bit + sign)
	Resolution of output frequency	0.1 Hz
	Frequency set value	-10..+10 V (20 kΩ), 0..20 mA (250 Ω), frequency setting value (selectable)
	Starting Torque	150% for Heavy duty, 120% for Normal duty
	Torque static accuracy	<3% in Vector control with feedback <3% in vector control without feedback if speed between 10 and 100%, <10% at 0 Hz
	Torque response	1 ms for 0 - 90% speed 5 ms for 90 - 100% speed (Close and open loop)
	Speed Control Accuracy	V/f control 1% Vector control without feedback 0.1% Vector control with feedback 0.01%
	Speed Response	0.4% without encoder feedback 0.2% with encoder feedback
	Torque Limit	From Analog input
	Accel/Decel Time	0.0 to 3600.0 s
Braking torque	5 - 10% (100% with external braking resistor)	
Functionality	Main Control Functions	PID, sleep function, brake control, torque control (Direct torque control model), Pump/Fan control, Logic functions, virtual connections, overvoltage control, undervoltage override, autoreset, two motor support, Lim Switch, External trip, Preset Speeds, MotPot Up Down, Pump Feedback, Timer, Mot PreMag , Jog, Ext Mot Temp, Loc/Rem, AnIn select, Brk Ackn.
Protection functions	Motor protection	Motor overheat protection based on output current or PTC by option board
	Momentary overcurrent Protection	Drive stops when output current exceeds 200% of peak current
	Overload Protection	Drive stops after 1 min at 150% of rated output current (Heavy Duty Rating) Drive stops after 1 min at 120% of rated output current (Normal Duty Rating) (1min every 10min)
	Overvoltage Protection	Line Overvoltage: 760 VDC during more than 10s for 400 V class; Fast Overvoltage: 850 VDC for 400 V class
	Undervoltage Protection	400 VDC for 400 V class (Adjustable by input power supply parameter)
	Momentary power loss Ride-Thru	Low voltage override function
	Heatsink Overheat Protection	Protected by thermister
	Braking Resistance Overheat Protection	Hardware short circuit protection
	Stall prevention	Current limit function
Power charge indication	Power LED remains lit until capacitors are charged	
Ambient conditions	Ambient Temperature	0°C..+40°C, up to 45°C with derating
	Ambient humidity	90% RH or less (without condensation)
	Storage temperature	-20°C..+60°C (short-term temperature during transportation)
	Altitude	Up to 1000 meters (output derating of 1% per 100 m above 1000 m, max. 2000 m)
	Vibration / Shock	According to IEC 600068-2-6, Sinusoidal vibrations: 10<f<57 Hz, 0.075 mm, 57<f<150 Hz, 1g
	Contamination, according to IEC 60721-3-3	No electrically conductive dust allowed. Cooling air must be clean and free from corrosive materials. Chemical gases, class 3C2. Solid particles, class 3S2
Protection Design	IP54 enclosure according to the EN 60529	

Frequency inverters

Dimensions

Standard dimensions IP54

SX-D40P7 to D47P5

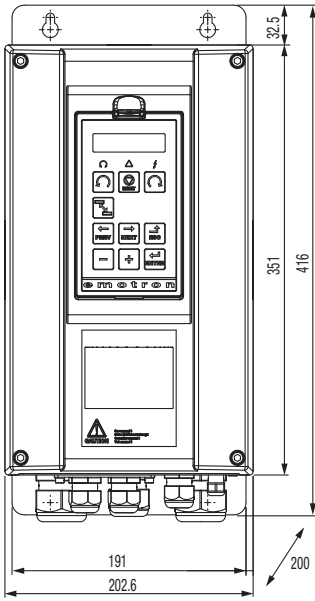

SX-D4011 to D4022

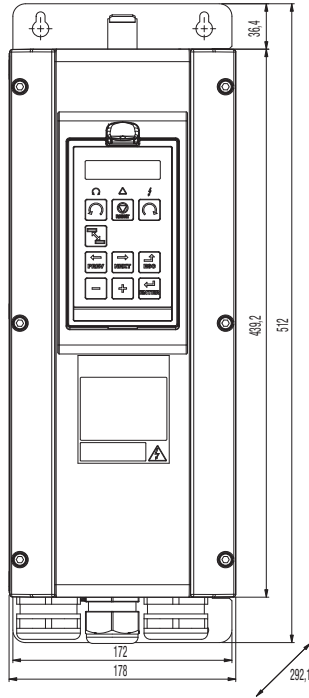

SX-D4030 to D4037

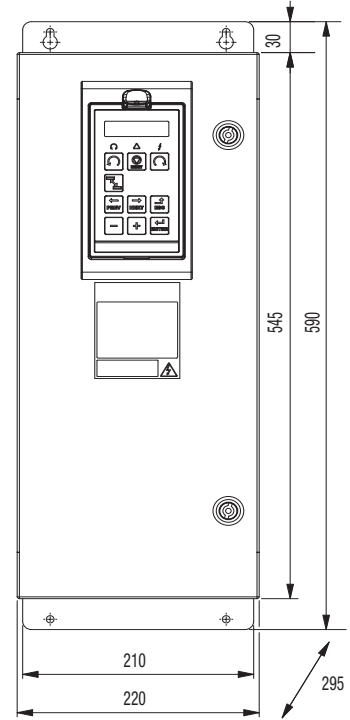

SX-D4045 to D4090

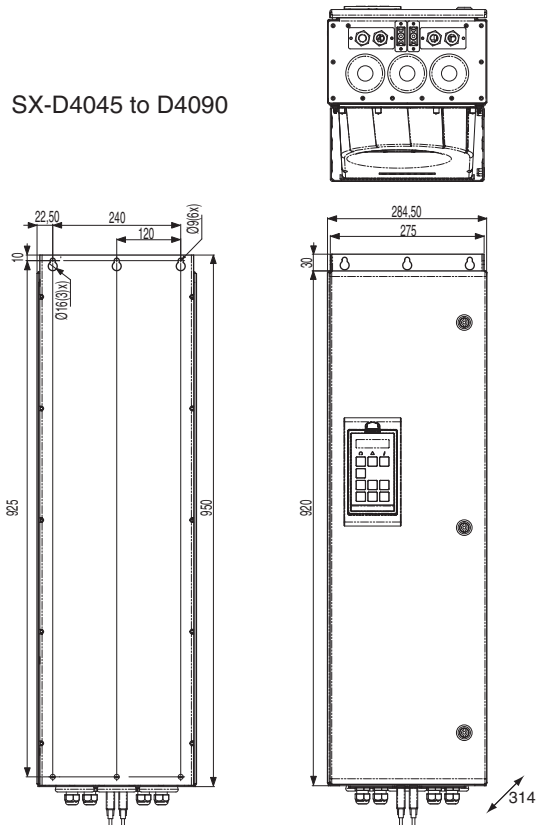

SX-D4110 to D4132

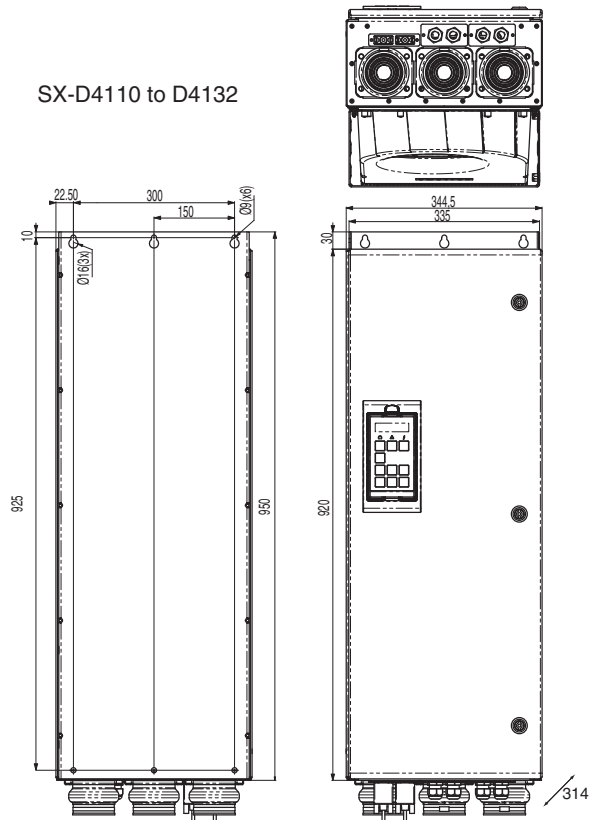

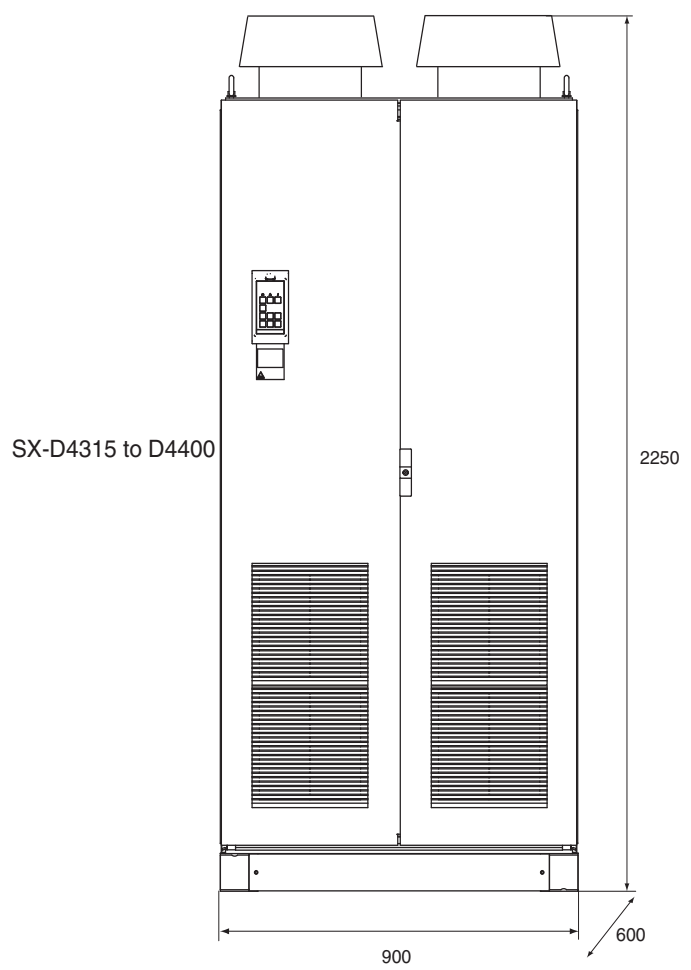
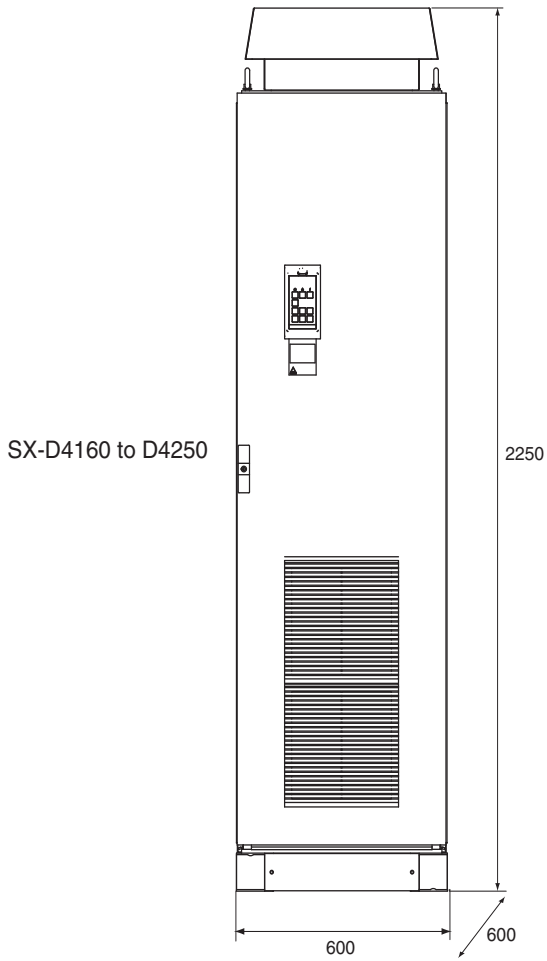

SX-D4450 to D4500

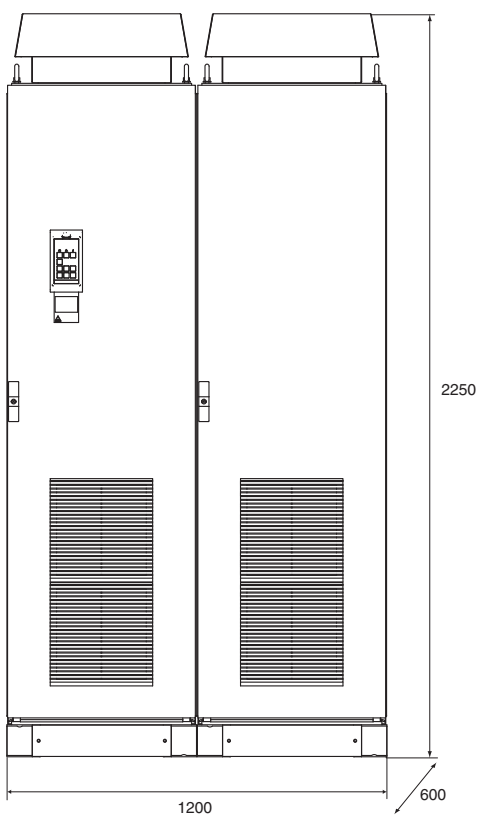

SX-D4630 to D4800

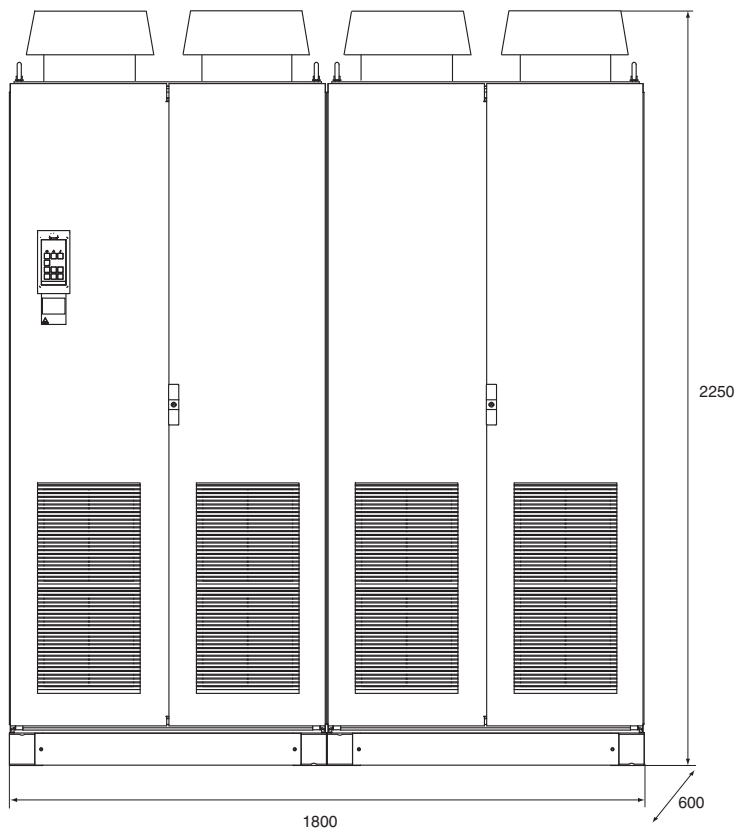

Standard dimensions IP20

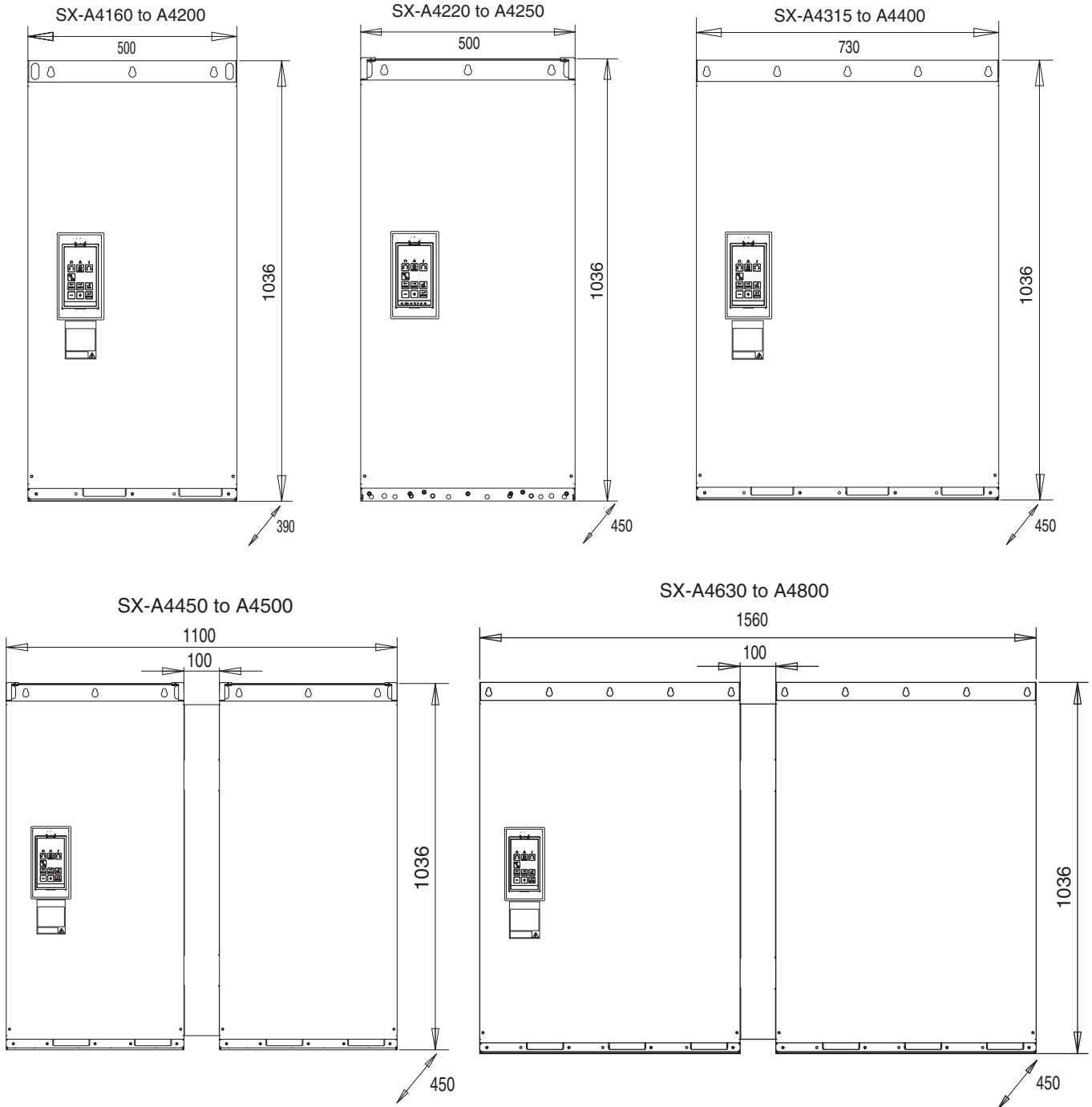

Weight and Air flow

Model SX-	Weight (Kg)		Air flow (m ³ /hour)
	SX-D (IP54)	SX-A (IP20)	
0P7 to 7P5	12.5	-	75
011 to 015	24	-	120
018 to 022	24	-	170
030 to 037	32	-	175
045 to 055	56	-	510
075 to 090	60	-	510
110 to 132	74	-	800
160 to 200	350	140	1020
220 to 250	380	170	1600
315 to 400	506	248	2400
450 to 500	697	340	3200
630 to 800	987	496	4800

LCD operator

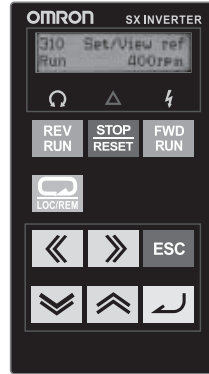

Output coils

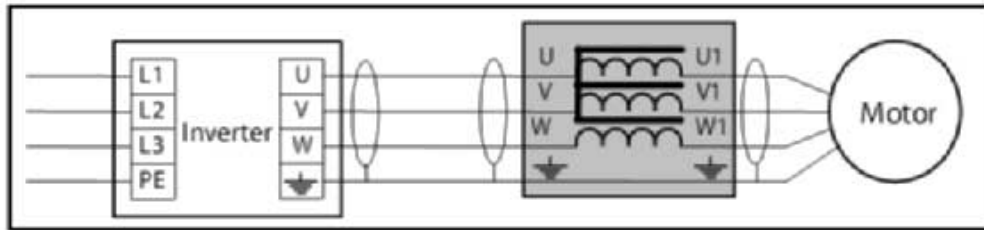
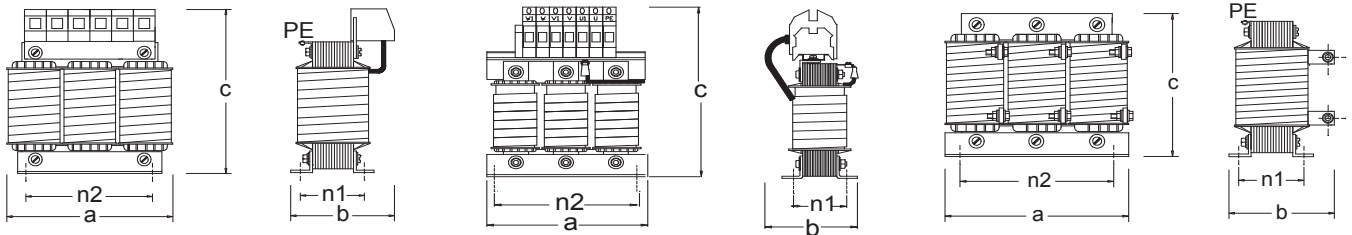

Figure 1

Figure 2

Figure 3



Type	Fig	a	b	c	n2	n1	Fix	Weight	Connection
473160 00	1	78	60	95	50	31	M4	0.6 kg	2.5 mm ²
473161 00									
473162 00									
473163 00									
473164 00									
473165 00									
473166 00	2	96	74	105	71	48	M4	1.2 kg	4 mm ²
473167 00									
473168 00									
473169 00	3	155	105	205	130	57	M5	4.0 kg	35 mm ²
473170 00									
473171 00	3	190	120	235	170	66	M6	8.4 kg	35 mm ²
473172 00									
473171 00	3	210	160	180	175	97	M6	13.4 kg	M10
473172 00									
473172 00	3	230	170	200	175	95	M6	18.4 kg	M10
473171 00									

Specifications

Model	Rated current	Inductance	Rated voltage	Max carrier	Max output frequency	Max temp	Protection Class
473160 00	2.8A	1.5 mH	800V	10 kHz	200Hz	40°C	IP00
473161 00	4.4A	1.0 mH					
473162 00	6.6A	0.65 mH					
473163 00	11.0A	0.4 mH					
473164 00	14.3A	0.3 mH					
473165 00	18.2A	0.25 mH					
473166 00	26.4A	0.17 mH5		6 kHz	200Hz	40°C	IP00
473167 00	32A	0.15 mH					
473168 00	65A	0.1 mH					
473169 00	90A	0.1 mH					
473170 00	146A	0.05 mH					
473171 00	175A	0.05 mH					
473172 00	275A	0.032 mH	1.5 kHz	100Hz	40°C	IP00	
473172 00	275A	0.032 mH					

Installation

Standard connections

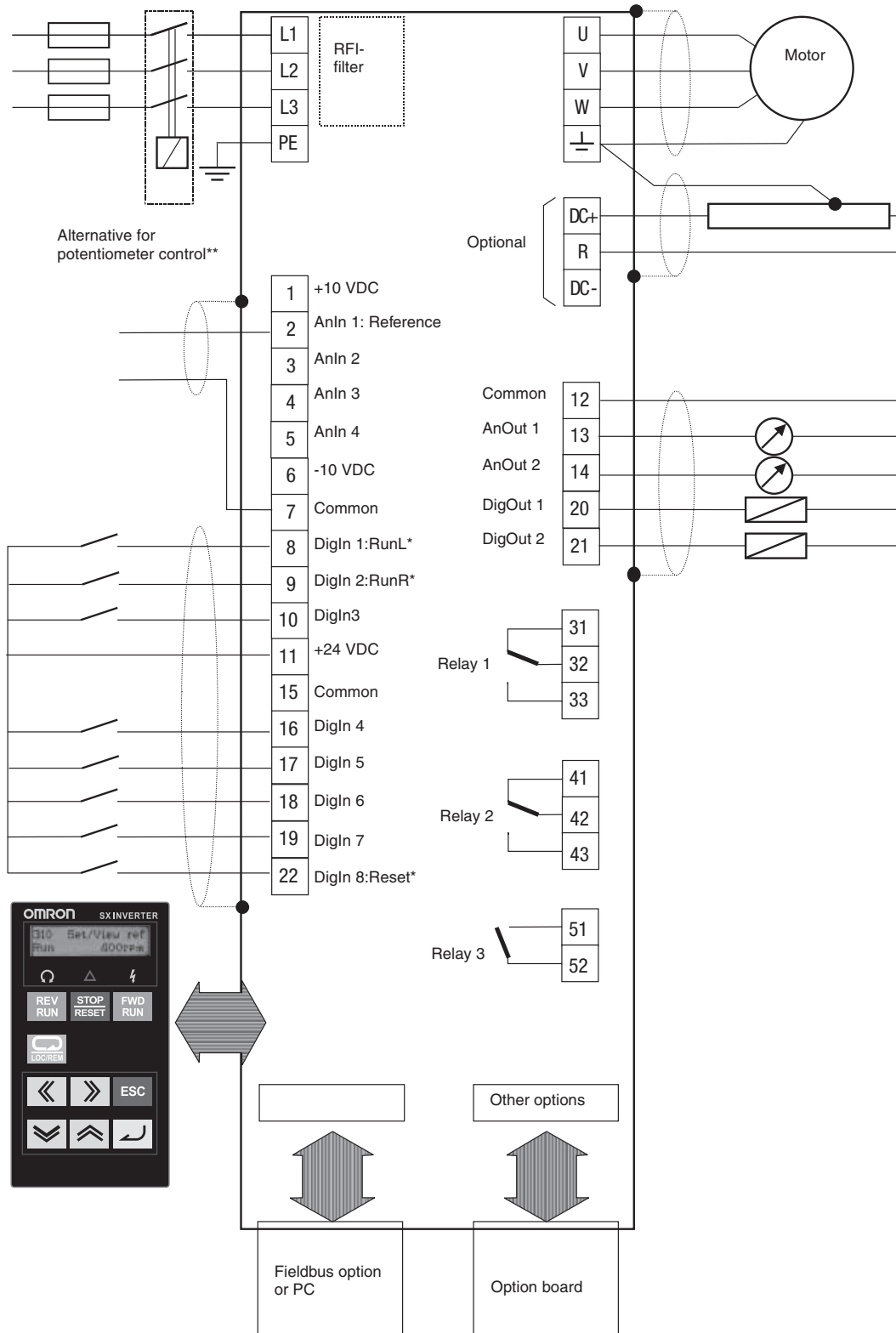

NG_06-F27

Main circuit

Terminal	Name	Function (signal level)
L1, L2, L3	Main circuit power supply input	Used to connect line power to the drive.
U, V, W	Inverter output	Used to connect the motor
DC-, DC+, R	DC link connections, Brake resistor	The brake resistor must be connected terminals DC+ and R (Terminals are only fitted if the Brake Chopper Option is built-in)
PE	Safety earth	Protected earth
	Grounding	Motor earth

Control Circuit

Type	No.	Signal name	Function	Signal level	
Digital input signals	8	DigIn 1	RunL (reverse)	High > 9 VDC Low < 4 VDC Max 30 VDC Impedance 4.7 kΩ for < 3.3 VDC 3.6 kΩ for > 3.3 VDC	
	9	DigIn 2	RunR (forward)		
	10	DigIn 3	Off		
	16	DigIn 4	Off		
	17	DigIn 5	Off		
	18	DigIn 6	Off		
	19	DigIn 7	Off		
	22	DigIn 8	RESET		
	11	+24 V	+24 VDC supply voltage	Max 100mA	
	15	Common	Signal ground		
Analog input signals	1	+10 V	+10 VDC supply voltage	-10 to 10 VDC 0 to 20mA Max 30V/30mA Impedance 20 kΩ Voltage 250 Ω Current	
	2	AnIn 1	Process Ref		
	3	AnIn 2	Off		
	4	AnIn 3	Off		
	5	AnIn 4	Off		
	6	-10 V	-10 VDC supply voltage		
	7	Common	Signal ground		
Digital output signals	20	DigOut 1	Ready	High > 20VDC @ 50mA > 23VDC open Low <1 VDC @ 50mA 100 mA max together with +24VDC	
	21	DigOut 2	Brake		
	12	Common	Signal ground		
	31	N/C 1	Relay 1 output Trip, active when the VSD is in a TRIP condition.	0.1 to 2A 250 VAC or 42 VDC	
	32	COM 1			
	33	N/O 1			
	41	N/C 2	Relay 2 output Run, active when the VSD is started.		
	42	COM 2			
	43	N/O 2			
	51	COM 3	Relay 3 output Off		
52	N/O 3				
Analog output signals	12	Common	Signal ground		0 - 10V / 0 - 20mA Max -15V @ 5mA Impedance: 10 Ω (Voltage)
	13	AnOut1	Min speed to max speed		
	14	AnOut2	0 to max torque		

Frequency inverters

Ordering information

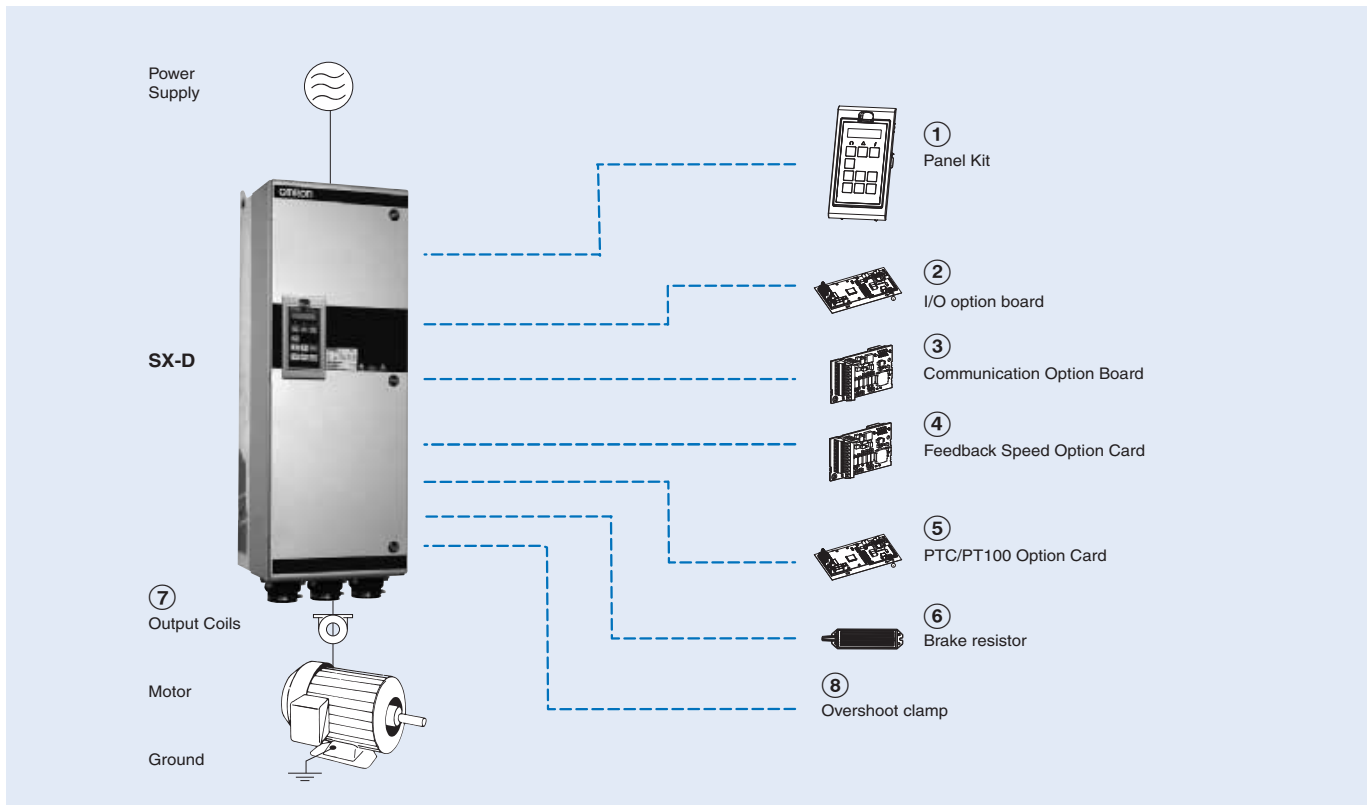

SX

Specifications					IP54 Model		IP20 Model	
Voltage	Heavy Duty		Normal Duty		Direct torque control	V/F	Direct torque control	V/F
400 V	0.55 kW	2.0 A	0.75 kW	2.5 A	SX-D40P7-EF	SX-D40P7-EV		
	1.1 kW	3.2 A	1.5 kW	4.0 A	SX-D41P5-EF	SX-D41P5-EV		
	1.5 kW	4.8 A	2.2 kW	6.0 A	SX-D42P2-EF	SX-D42P2-EV		
	2.2 kW	6.0 A	3 kW	7.5 A	SX-D43P0-EF	SX-D43P0-EV		
	3 kW	7.6 A	4 kW	9.5 A	SX-D44P0-EF	SX-D44P0-EV		
	4 kW	10.4 A	5.5 kW	13 A	SX-D45P5-EF	SX-D45P5-EV		
	5.5 kW	14.4 A	7.5 kW	18 A	SX-D47P5-EF	SX-D47P5-EV		
	7.5 kW	21 A	11 kW	26 A	SX-D4011-EF	SX-D4011-EV		
	11 kW	25 A	15 kW	31 A	SX-D4015-EF	SX-D4015-EV		
	15 kW	29.6 A	18.5 kW	37 A	SX-D4018-EF	SX-D4018-EV		
	18.5 kW	37 A	22 kW	46 A	SX-D4022-EF	SX-D4022-EV		
	22 kW	49 A	30 kW	61 A	SX-D4030-EF	SX-D4030-EV		
	30 kW	59 A	37 kW	74 A	SX-D4037-EF	SX-D4037-EV		
	37 kW	72 A	45 kW	90 A	SX-D4045-EF	SX-D4045-EV		
	45 kW	87 A	55 kW	109 A	SX-D4055-EF	SX-D4055-EV		
	55 kW	117 A	75 kW	146 A	SX-D4075-EF	SX-D4075-EV		
	75 kW	140 A	90 kW	175 A	SX-D4090-EF	SX-D4090-EV		
	90 kW	168 A	110 kW	210 A	SX-D4110-EF	SX-D4110-EV		
	110 kW	200 A	132 kW	250 A	SX-D4132-EF	SX-D4132-EV		
	132 kW	240 A	160 kW	300 A	SX-D4160-EF	SX-D4160-EV	SX-A4160-EF	SX-A4160-EV
	160 kW	300 A	200 kW	375 A	SX-D4200-EF	SX-D4200-EV	SX-A4200-EF	SX-A4200-EV
	200 kW	344 A	220 kW	430 A	SX-D4220-EF	SX-D4220-EV	SX-A4220-EF	SX-A4220-EV
	220 kW	400 A	250 kW	500 A	SX-D4250-EF	SX-D4250-EV	SX-A4250-EF	SX-A4250-EV
	250 kW	480 A	315 kW	600 A	SX-D4315-EF	SX-D4315-EV	SX-A4315-EF	SX-A4315-EV
	315 kW	520 A	355 kW	650 A	SX-D4355-EF	SX-D4355-EV	SX-A4355-EF	SX-A4355-EV
	355 kW	600 A	400 kW	750 A	SX-D4400-EF	SX-D4400-EV	SX-A4400-EF	SX-A4400-EV
	400 kW	688 A	450 kW	680 A	SX-D4450-EF	SX-D4450-EV	SX-A4450-EF	SX-A4450-EV
	450 kW	800 A	500 kW	1000 A	SX-D4500-EF	SX-D4500-EV	SX-A4500-EF	SX-A4500-EV
500 kW	960 A	630 kW	1200 A	SX-D4630-EF	SX-D4630-EV	SX-A4630-EF	SX-A4630-EV	
630 kW	1200 A	800 kW	1500 A	SX-D4800-EF	SX-D4800-EV	SX-A4800-EF	SX-A4800-EV	

① Panel Kit

Model	Description	Function
01-3957-00	Panel kit	Panel kit complete including panel
01-3957-01	Blank panel kit	Panel kit complete including blank panel

② I/O option board

Model	Description	Function
01-3876-01	Additional I/O option	Provides 3 extra relay outputs and 3 additional digital inputs
01-3876-07	Crane option	Dedicated option board for crane application, including additional I/O and functions

③ Communication option board

Type	Model	Description	Function
Communication option board	01-3876-04	RS232/485	• MODBUS RTU serial communication by RS232 or RS485 interface with galvanic isolation
	01-3876-05	PROFIBUS-DP option card	• Used for operating the inverter through PROFIBUS-DP communication with the host controller.
	01-3876-06	DeviceNet option card	• Used for operating the inverter through DeviceNet communication with the host controller.
	01-3876-09	Modbus/TCP, Ethernet	• Used for operating the inverter through Modbus/TCP communication with the host controller.

④ Encoder feedback option card

Model	Description	Function
01-3876-03	Encoder option	Used for connection of the actual motor speed via encoder. Up to 100kHz with TTL and HTL incremental encoders with 5/24 V power supply

⑤ PTC/PT100 option card

Model	Description	Function
01-3876-08	Thermal protection	Allows to connect a motor thermistor to the inverter

⑥ Braking chopper and braking resistor

All inverter sizes could be fitted with an optional built-in brake chopper from factory but is not possible to install it later. The choice of the resistor depends on the application switch-on duration and duty-cycle. Following tables describes the activation level of the built-in braking chopper and the minimum resistor that could be used depending on the input voltage.

Type	R for different input voltage (Ω)			Type	R for different input voltage (Ω)		
	220-240 VAC	380-415 VAC	440-480 VAC		220-240 VAC	380-415 VAC	440-480 VAC
SX-40P7	43	43	50	SX-4075	3.8	3.8	4.4
SX-41P5	43	43	50	SX-4090	3.8	3.8	4.4
SX-42P2	43	43	50	SX-4110	2.7	2.7	3.1
SX-43P0	43	43	50	SX-4132	2.7	2.7	3.1
SX-44P0	43	43	50	SX-4160	2 x 3.8	2 x 3.8	2 x 4.4
SX-45P5	43	43	50	SX-4200	2 x 3.8	2 x 3.8	2 x 4.4
SX-47P5	43	43	50	SX-4220	2 x 2.7	2 x 2.7	2 x 3.1
SX-4011	26	26	30	SX-4250	2 x 2.7	2 x 2.7	2 x 3.1
SX-4015	26	26	30	SX-4315	3 x 2.7	3 x 2.7	3 x 3.1
SX-4018	17	17	20	SX-4355	3 x 2.7	3 x 2.7	3 x 3.1
SX-4022	17	17	20	SX-4400	3 x 2.7	3 x 2.7	3 x 3.1
SX-4030	9.7	9.7	N/A	SX-4450	4 x 2.7	4 x 2.7	4 x 3.1
SX-4037	9.7	9.7	N/A	SX-4500	4 x 2.7	4 x 2.7	4 x 3.1
SX-4045	3.8	3.8	4.4	SX-4630	6 x 2.7	6 x 2.7	6 x 3.1
SX-4055	3.8	3.8	4.4		-	-	-

Supply voltage (VAC)	Built-in brake chopper trigger level (VDC)
220-240	380
380-415	660
440-480	780

⑦ Output coils

Output coils above SX-D4132-E should be order from factory as they should be installed inside of the cabinet

Voltage	Inverter model	Model	Rated current	Inductance	Rated Voltage	Max carrier	Max output frequency	Max temp
400V	SX-40P7-E	473160 00	2.8A	1.5 mH	800V	10 KHz	200	40°C
	SX-41P5-E	473161 00	4.4A	1.0 mH				
	SX-42P2-E	473162 00	6.6A	0.65 mH				
	SX-43P0-E	473163 00	11.0A	0.4 mH				
	SX-44P0-E							
	SX-45P5-E	473164 00	14.3A	0.3 mH				
	SX-47P5-E	473165 00	18.2A	0.25 mH				
	SX-4011-E	473166 00	26.4A	0.175 mH				
	SX-4015-E	473167 00	32A	0.15 mH				
	SX-4018-E	473168 00	65A	0.1 mH				
	SX-4022-E							
	SX-4030-E							
	SX-4037-E	473169 00	90A	0.1 mH				
	SX-4045-E							
	SX-4055-E	473170 00	146A	0.05 mH				
	SX-4075-E	473171 00	175A	0.05 mH				
SX-4090-E								
SX-4110-E								
SX-4132-E	473172 00	275A	0.032 mH	1.5 KHz	100			

⑧ Overshoot clamp

Only two types of overshoot clamps could be order for after mounting

Model	Inverter	Function
52163	SX-40P7 to SX-4132	Together with the output coils, the overshoot clamp restricts the voltage and the dV/dt on the motor winding. Inverters must be ordered including the option DC+/DC- connectors.
52220	SX-4160 to SX-4800	Together with the output coils, the overshoot clamp restricts the voltage and the dV/dt on the motor winding. Doesn't require the "DC+/DC-" option.

Computer software

Types	Model	Description	Installation
Software	CX-drive	Computer software	Configuration and monitoring software tool
	CX-One	Computer software	Configuration and monitoring software tool
	€Saver	Computer software	Software tool for Energy Saving calculation

ALL DIMENSIONS SHOWN ARE IN MILLIMETERS.
To convert millimeters into inches, multiply by 0.03937. To convert grams into ounces, multiply by 0.03527.

SX (690 V)

High performance Vector Control

- IP54 full range.
- Compact design & Robustness
- Built-in Filter according to C3 Class
- Built-in Fuses (From 200kW)
- Safety according EN13849-1 and EN62601 standards
- Load curve control
- HCB technology (Half controlling Bridge)
- Logic programmability
- Pre-maintenance alarms
- Options flexibility (I/O's, Fieldbus, PTC/PT100, Multiple Pump control, Encoder, Crane control)
- Communications options (Modbus, Dnet, Profibus)
- 24Vdc control board supply
- Liquid cooling drive version
- 12-pulse rectifier option.
- Flexible cable connections & User Friendly wiring connection
- CE, UL, RoHS, DNV

Ratings

- 690 V Class three-phase 90 to 1000 kW



System configuration

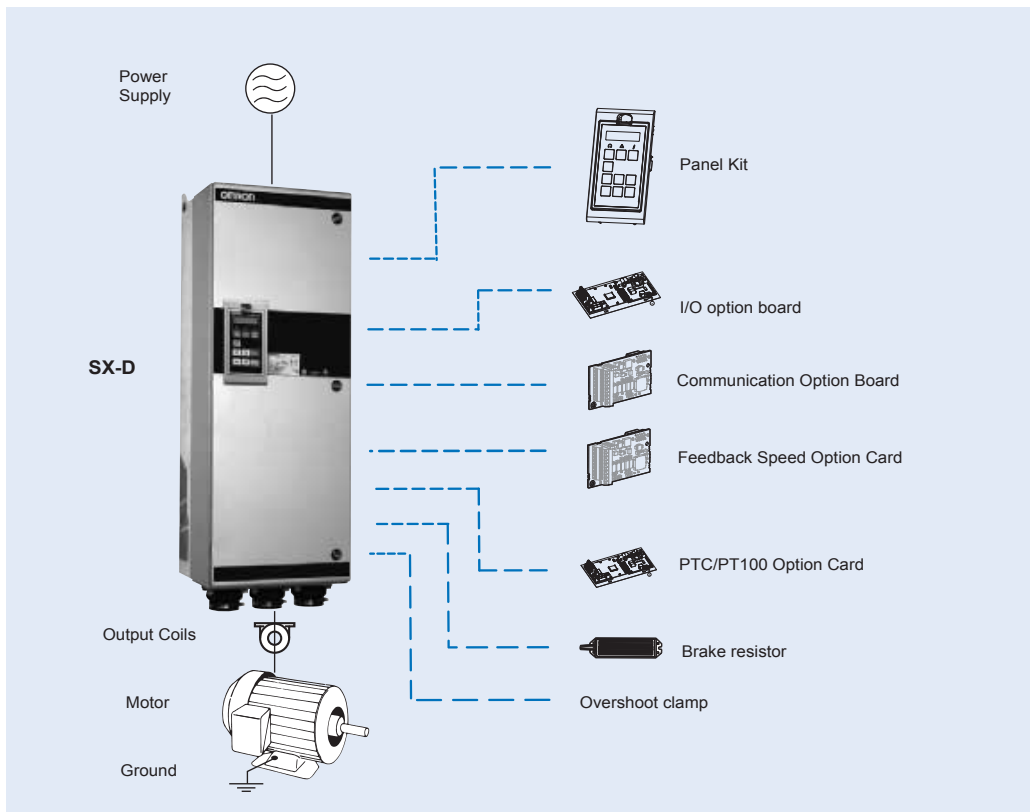

Specifications

Type designation

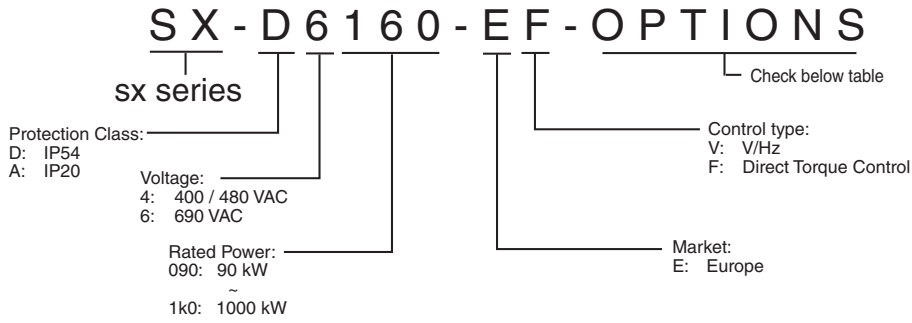

Options available

Options	Letter ("?" means no character)	Options	Letter ("?" means no character)
Control panel	"?" = Standard control panel (Std.PPU) "A" = Blank control panel (Blank PPU)	Option board position 3	"?" = No option "I" = Encoder "J" = PTC/PT100 "K" = Extended I/O"
Built-in EMC filter	"?" = Standard EMC inside (Category C3) "B" = IT-Net (filter disconnected from ground)	Option board Fieldbus position 4	"?" = No option "L" = DeviceNet "M" = Profibus-DP "N" = RS232/485 "O" = EtherNet Modbus TCP
Built-in brake chopper	"?" = No brake chopper or DC-connection included "C" = Brake chopper & DC-connection included "D" = Only DC-connection included	Liquid Cooling	"?" = No Liquid Cooling "P" = Liquid Cooling
Standby power supply	"?" = Not included "E" = Standby power supply included	Standard	"?" = IEC "Q" = UL
Safe stop	"?" = Not included "F" = Safe stop included	Marine	"?" = No marine option "R" = Marine option included
Coated boards	"?" = No coating "G" = Coated boards	Cabinet input options	"?" = No cabinet input options "S" = Main switch included "T" = Main contactor included "U" = Main switch + contactor included
Option board position 1	"?" = No option "H" = Crane I/O "I" = Encoder "J" = PTC/PT100 "K" = Extended I/O"	Cabinet output options	"?" = No cabinet output options included "V" = dV/dt filter included "W" = dV/dt filter + Overshoot clamp included "X" = Sinusfilter included
Option board position 2	"?" = No option "I" = Encoder "J" = PTC/PT100 "K" = Extended I/O"		

600 V class

Three-phase: SX-D6□□-EF		90	110	132	160	200	250	315	355	450	500	600	630	710	800	900	1K0
Motor kW ¹	For HD setting	75	90	110	132	160	200	250	315	315	355	450	500	600	650	710	800
	For ND setting	90	110	132	160	200	250	315	355	450	500	600	630	710	800	900	1000
Output characteristics	Max output current (A)	108	131	175	210	252	300	360	450	516	600	720	780	900	1032	1080	1200
	Rated output current (A) at HD	72	87	117	140	168	200	240	300	344	400	480	520	600	688	720	800
	Rated output current (A) at ND ³	90	109	146	175	210	250	300	375	430	500	600	650	750	860	900	1000
	Output voltage	0 to Mains supply voltage															
	Max. output frequency	400 Hz															
Power supply	Rated input voltage and frequency	3-phase 500..690V, 50/60 Hz															
	Allowable voltage fluctuation	+10%..-15%															
	Allowable frequency fluctuation	45 to 65 Hz															

Specifications

Common specifications

Model number SX-	Specifications	
Control functions	Control methods	V/f control for "V" type V/f control, Vector control with or without feedback for the "F" type
	Output frequency range	0.0..400 Hz
	Frequency tolerance	Analogue set value: 1% + 1.5 LSB f _{sd}
	Resolution of frequency set value	Digital set value: 0.1 Hz
	Resolution of output frequency	Analogue set value: 0.03 Hz / 60 Hz (11 bit + sign)
	Frequency set value	-10..+10 V (20 kΩ), 0..20 mA (250 Ω), frequency setting value (selectable)
	Starting Torque	150% for Heavy duty, 120% for Normal duty
	Torque static accuracy	<3% in Vector control with feedback <3% in vector control without feedback if speed between 10 and 100%, <10% at 0 Hz
	Torque response	1ms for 0 - 90% speed 5ms for 90 - 100% speed (Close and open loop)
	Speed Control Accuracy	V/f control 1% Vector control without feedback 0.1% Vector control with feedback 0.01%
	Speed Response	0.4% without encoder feedback 0.2% with encoder feedback
	Torque Limit	From Analog input
	Accel/Decel Time	0.0 to 3600.0 s
	Braking torque	5 - 10% (100% with external braking resistor)
Functionality	Main Control Functions PID, sleep function, brake control, torque control (Direct torque control model), Pump/Fan control, Logic functions, virtual connections, overvoltage control, undervoltage override, autoreset, two motor support, Lim Switch, External trip, Preset Speeds, MotPot Up Down, Pump Feedb, Timer, Mot PreMag , Jog, Ext Mot Temp, Loc/Rem, AnIn select, Brk Ackn.	
Protection functions	Motor protection	Motor overheat protection based on output current or PTC by option board
	Momentary overcurrent Protection	Drive stops when output current exceeds 200% of peak current
	Overload Protection	Drive stops after 1 min at 150% of rated output current (Heavy Duty Rating) Drive stops after 1 min at 120% of rated output current (Normal Duty Rating) (1min every 10min)
	Overvoltage Protection	Line Overvoltage: 1120 VDC during more than 10s for 690V class Fast Overvoltage: 1220 for 690 VDC
	Undervoltage Protection	500 for 690V class (Adjustable by input power supply parameter)
	Momentary power loss Ride-Thru	Low voltage override function
	Heatsink Overheat Protection	Protected by thermister
	Braking Resistance Overheat Protection	Hardware short circuit protection
	Stall prevention	Current limit function
Power charge indication	Power LED remains lit while capacitors are charged	
Ambient conditions	Ambient Temperature	0°C..+40 °C, up to 45 °C with derating
	Ambient humidity	90% RH or less (without condensation)
	Storage temperature	-20 °C..+60 °C (short-term temperature during transportation)
	Altitude	Up to 1000 meters (output derating of 1% per 100 m above 1000 m, max. 2000 m)
	Vibration / Shock	According to IEC 600068-2-6, Sinusoidal vibrations: 10<f<57 Hz, 0.075 mm, 57<f<150 Hz, 1g
	Contamination, according to IEC 60721-3-3	No electrically conductive dust allowed. Cooling air must be clean and free from corrosive materials. Chemical gases, class 3C2. Solid particles, class 3S2
	Protection Design	IP54 enclosure according to the EN 60529, IP20

Standard dimensions IP54

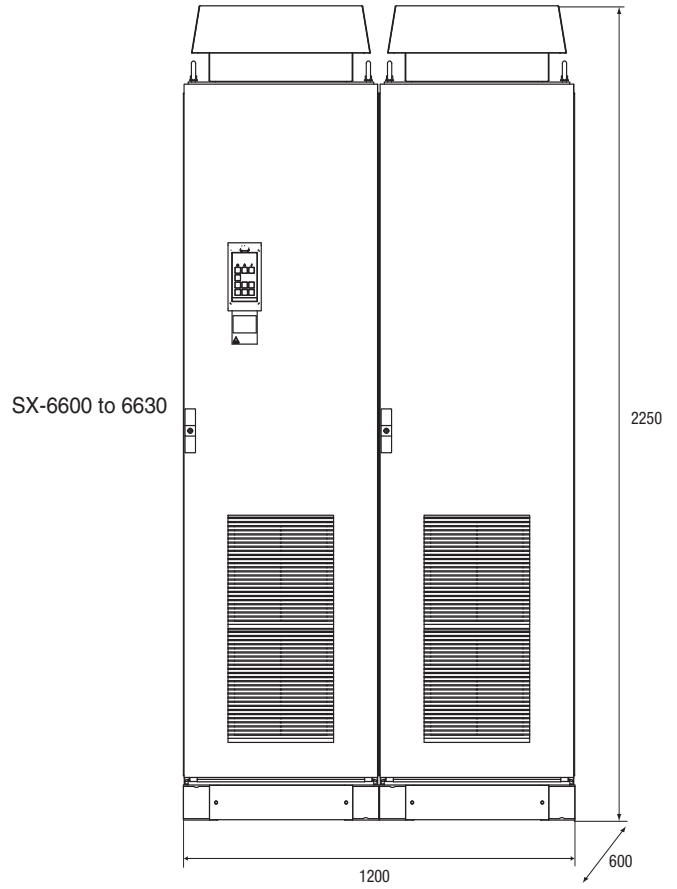
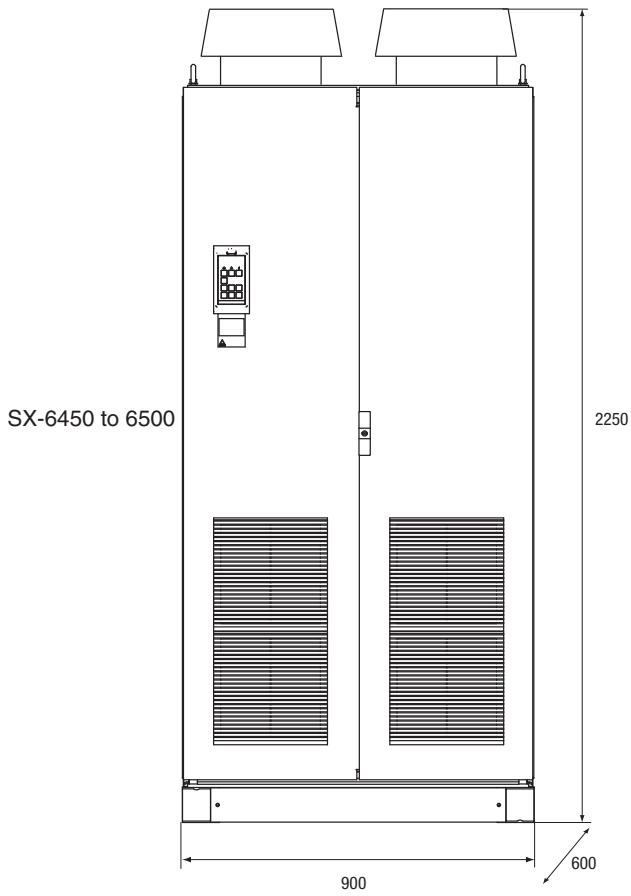
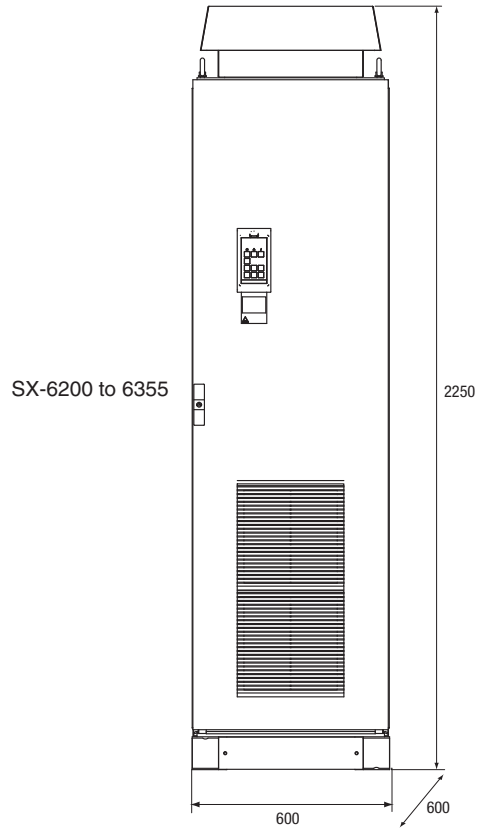
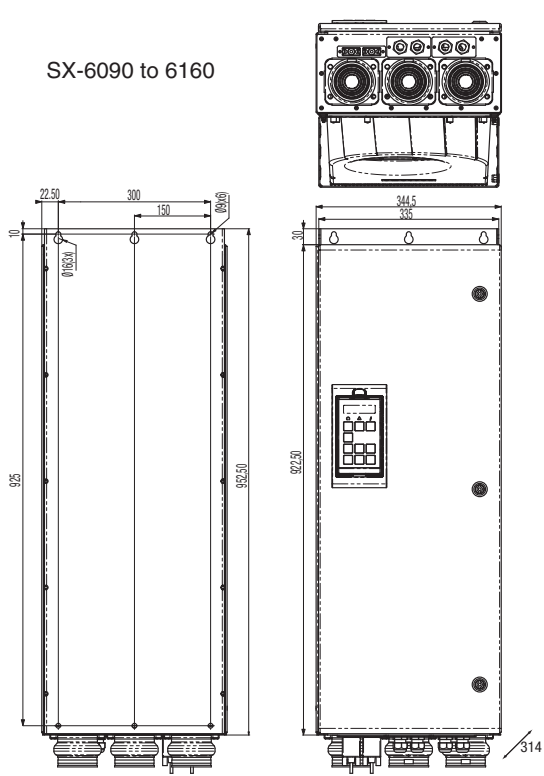

SX-6710 to 61K0

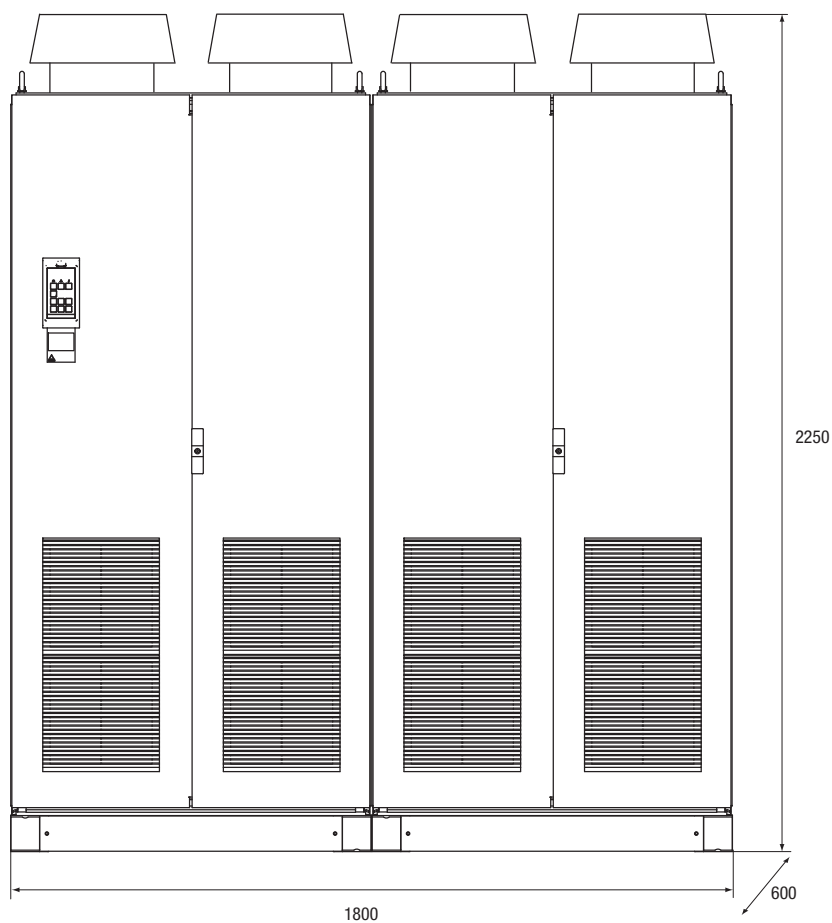

Frequency inverters

Standard dimensions IP20

SX-A6200 to A6375

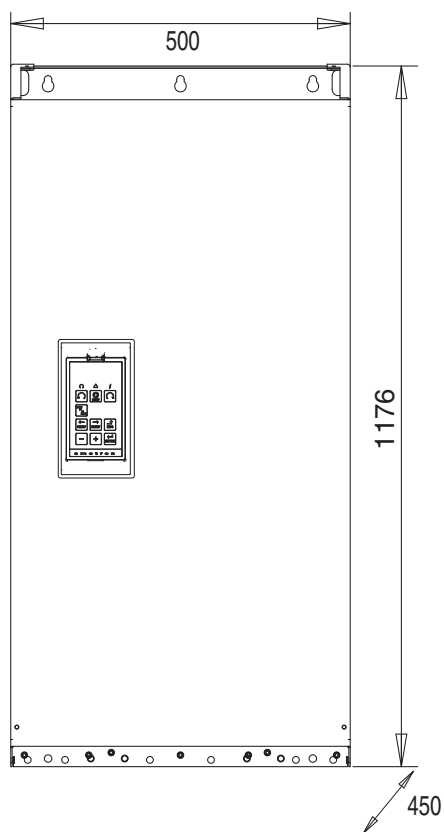

SX-A6450 to A4500

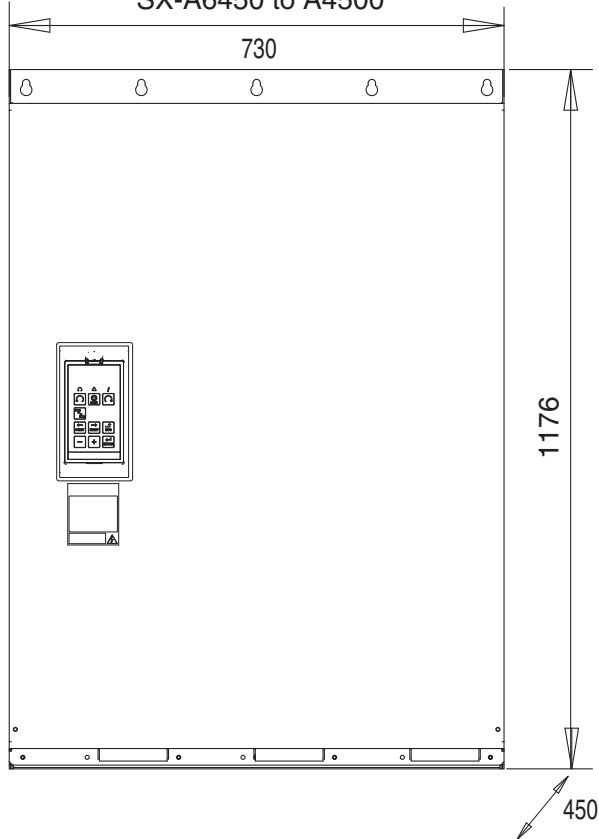

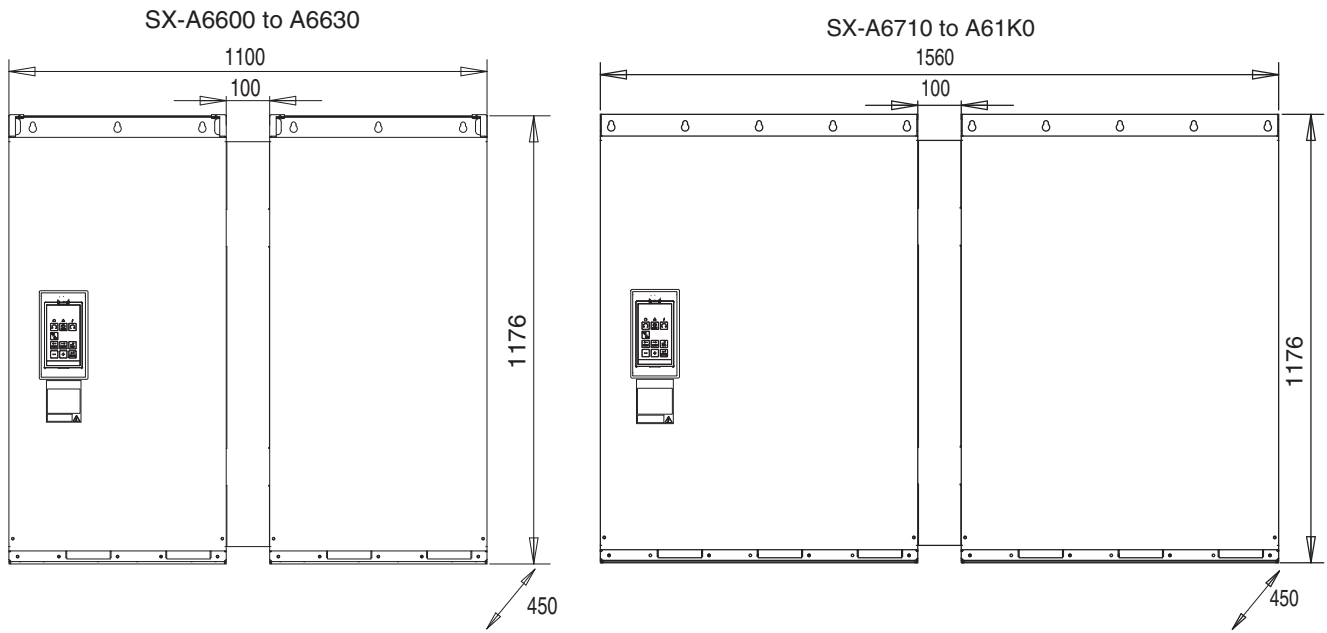

Weight and Air flow

Model SX-	Weight (Kg)		Air flow (m ³ /hour)
	SX-D (IP54)	SX-A (IP20)	
090 to 160	77	-	800
200 to 355	399	176	1600
450 to 500	563	257	2400
600 to 630	773	352	3200
710 to 1K0	1100	514	4800

LCD operator

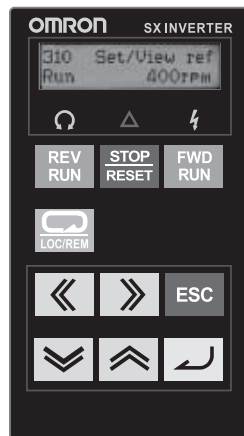

Output coils

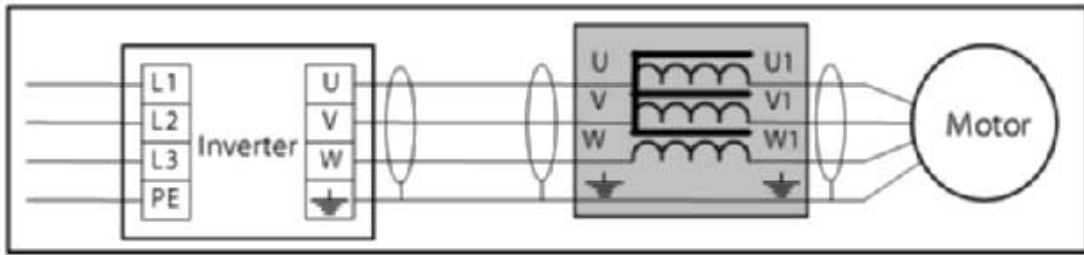
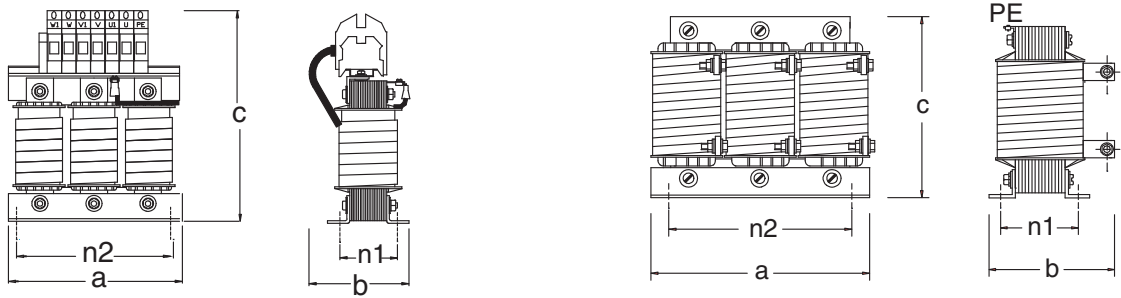

Figure 1

Figure 2



Type	Fig	a	b	c	n2	n1	Fix	Weight	Connection
473169 00	1	190	120	235	170	66	M6	8.4 kg	35 mm ²
473170 00		190	140	260	170	77	M6	10.2 kg	35 mm ²
473171 00	2	210	160	180	175	97	M6	13.4 kg	M10
473172 00		230	170	200	175	95	M6	18.4 kg	M10

Specifications

Model	Rated current	Inductance	Rated voltage	Max carrier	Max output frequency	Max temp	Protection Class
473169 00	90A	0.1 mH	800V	6 kHz	200Hz	40°C	IP00
473170 00	146A	0.05 mH					
473171 00	175A	0.05 mH		1.5 kHz	100Hz		
473172 00	275A	0.032 mH					

Installation

Standard connections

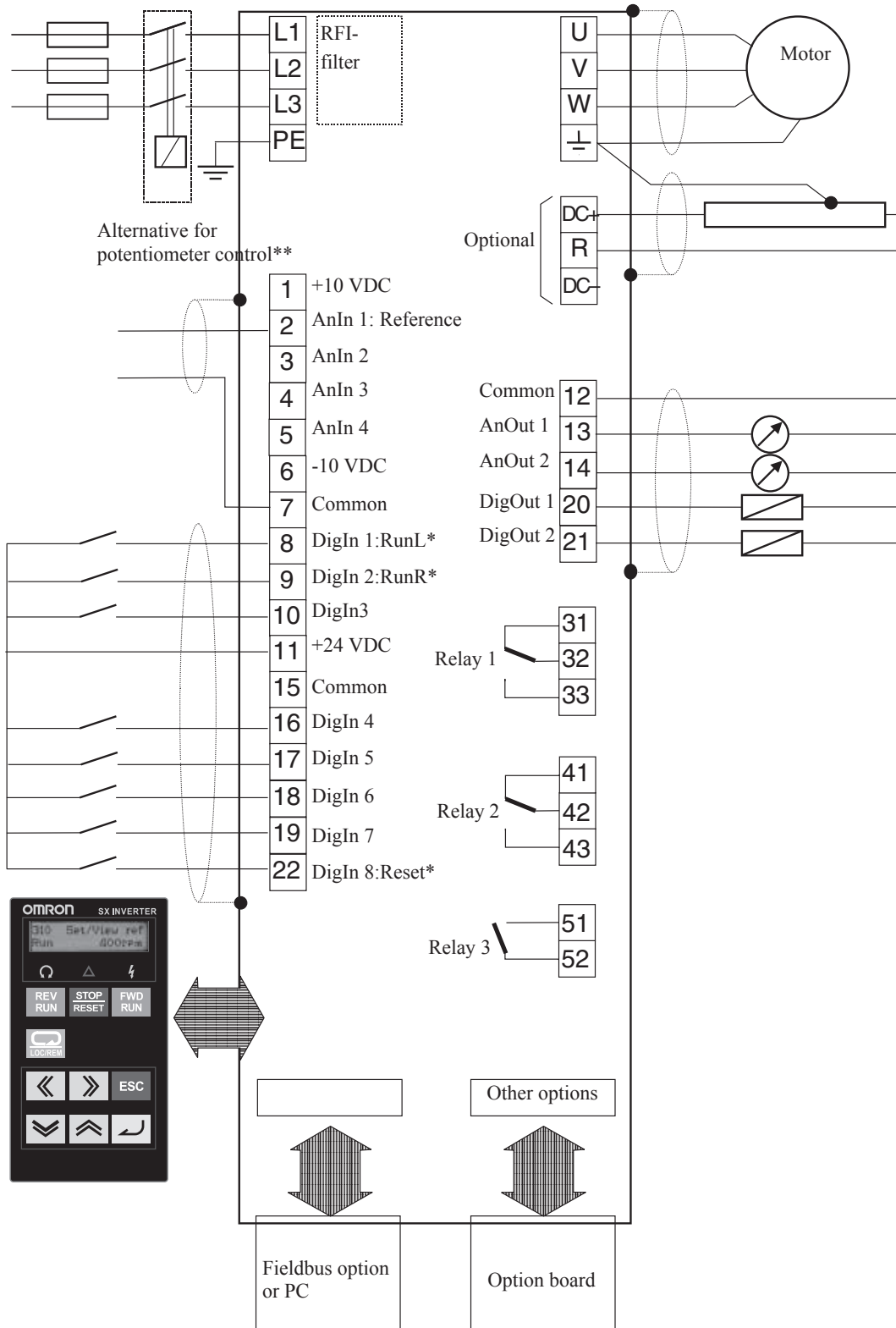

NG_06-F27

Main circuit

Terminal	Name	Function (signal level)
L1, L2, L3	Main circuit power supply input	Used to connect line power to the drive.
U, V, W	Inverter output	Used to connect the motor
DC-, DC+, R	DC link connections, Brake resistor	The brake resistor must be connected terminals DC+ and R (Terminals are only fitted if the Brake Chopper Option is built-in)
PE	Safety earth	Protected earth
	Grounding	Motor earth

Control Circuit

Type	No.	Signal name	Function	Signal level	
Digital input signals	8	DigIn 1	RunL (reverse)	High > 9 VDC Low < 4 VDC Max 30 VDC Impedance 4.7 kW for < 3.3 VDC 3.6 kW for > 3.3 VDC	
	9	DigIn 2	RunR (forward)		
	10	DigIn 3	Off		
	16	DigIn 4	Off		
	17	DigIn 5	Off		
	18	DigIn 6	Off		
	19	DigIn 7	Off		
	22	DigIn 8	RESET		
	11	+24 V	+24 VDC supply voltage	Max 100mA	
	15	Common	Signal ground		
Analog input signals	1	+10 V	+10 VDC supply voltage	-10 to 10 VDC 0 to 20mA Max 30V/30mA Impedance 20 kW Voltage 250 W Current	
	2	AnIn 1	Process Ref		
	3	AnIn 2	Off		
	4	AnIn 3	Off		
	5	AnIn 4	Off		
	6	-10 V	-10 VDC supply voltage		
	7	Common	Signal ground		
Digital output signals	20	DigOut 1	Ready	High > 20VDC @ 50mA > 23VDC open Low <1 VDC @ 50mA 100 mA max together with +24VDC	
	21	DigOut 2	Brake		
	12	Common	Signal ground		
	31	N/C 1	Relay 1 output Trip, active when the VSD is in a TRIP condition.	0.1 to 2A 250 VAC or 42 VDC	
	32	COM 1			
	33	N/O 1			
	41	N/C 2	Relay 2 output Run, active when the VSD is started.		
	42	COM 2			
	43	N/O 2			
	51	COM 3	Relay 3 output Off		
52	N/O 3				
Analog output signals	12	Common	Signal ground		0 - 10V / 0 - 20mA Max -15V @ 5mA Impedance: 10 W (Voltage)
	13	AnOut1	Min speed to max speed		
	14	AnOut2	0 to max torque		

Ordering information

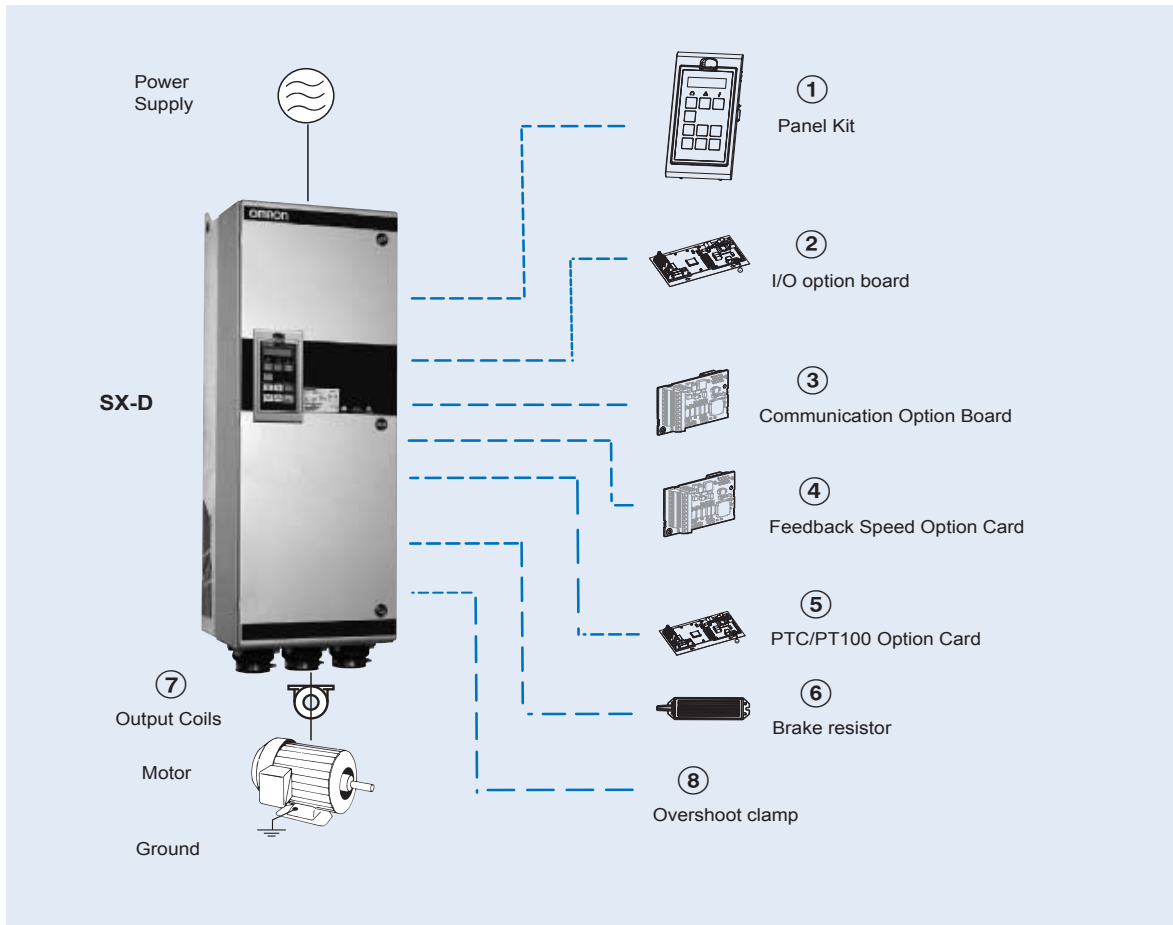

SX

Specifications				IP54 Model		IP20 Model		
Voltage	Heavy Duty	Normal Duty		Direct torque control	V/F	Direct torque control	V/F	
690 V	75 kW	72 A	90 kW	90 A	SX-D6090-EF	SX-D6090-EV		
	90 kW	87 A	110 kW	109 A	SX-D6110-EF	SX-D6110-EV		
	110 kW	117 A	132 kW	146 A	SX-D6132-EF	SX-D6132-EV		
	132 kW	140 A	160 kW	175 A	SX-D6160-EF	SX-D6160-EV		
	160 kW	168 A	200 kW	210 A	SX-D6200-EF	SX-D6200-EV		
	200 kW	200 A	250 kW	250 A	SX-D6250-EF	SX-D6250-EV	SX-A6250-EF	SX-A6250-EV
	250 kW	240 A	315 kW	300 A	SX-D6315-EF	SX-D6315-EV	SX-A6315-EF	SX-A6315-EV
	315 kW	300 A	355 kW	375 A	SX-D6355-EF	SX-D6355-EV	SX-A6355-EF	SX-A6355-EV
	315 kW	344 A	450 kW	430 A	SX-D6450-EF	SX-D6450-EV	SX-A6450-EF	SX-A6450-EV
	355 kW	400 A	500 kW	500 A	SX-D6500-EF	SX-D6500-EV	SX-A6500-EF	SX-A6500-EV
	450 kW	480 A	600 kW	600 A	SX-D6600-EF	SX-D6600-EV	SX-A6600-EF	SX-A6600-EV
	500 kW	520 A	630 kW	650 A	SX-D6630-EF	SX-D6630-EV	SX-A6630-EF	SX-A6630-EV
	600 kW	600 A	710 kW	750 A	SX-D6710-EF	SX-D6710-EV	SX-A6710-EF	SX-A6710-EV
	650 kW	688 A	800 kW	860 A	SX-D6800-EF	SX-D6800-EV	SX-A6800-EF	SX-A6800-EV
710 kW	720 A	900 kW	900 A	SX-D6900-EF	SX-D6900-EV	SX-A6900-EF	SX-A6900-EV	
800 kW	800 A	1000 kW	1000 A	SX-D61K0-EF	SX-D61K0-EV	SX-A61K0-EF	SX-A61K0-EV	

① Panel Kit

Model	Description	Function
01-3957-00	Panel kit	Panel kit complete including panel
01-3957-01	Blank panel kit	Panel kit complete including blank panel

② I/O option board

Model	Description	Function
01-3876-01	Additional I/O option	Provides 3 extra relay outputs and 3 additional digital inputs
01-3876-07	Crane option	Dedicated option board for crane application, including additional I/O and functions

③ Communication option board

Type	Model	Description	Function
Communication option board	01-3876-04	RS232/485	• MODBUS RTU serial communication by RS232 or RS485 interface with galvanic isolation
	01-3876-05	PROFIBUS-DP option card	• Used for operating the inverter through PROFIBUS-DP communication with the host controller.
	01-3876-06	DeviceNet option card	• Used for operating the inverter through DeviceNet communication with the host controller.
	01-3876-09	Modbus/TCP, Ethernet	• Used for operating the inverter through Modbus/TCP communication with the host controller.

④ Encoder feedback option card

Model	Description	Function
01-3876-03	Encoder option	Used for connection of the actual motor speed via encoder. Up to 100kHz with TTL and HTL incremental encoders with 5/24 V power supply

⑤ PTC/PT100 option card

Model	Description	Function
01-3876-08	Thermal protection	Allows to connect a motor thermistor to the inverter

⑥ Braking chopper and braking resistor

All inverter sizes could be fitted with an optional built-in brake chopper from factory but is not possible to install it later. The choice of the resistor depends on the application switch-on duration and duty-cycle. Following tables describes the activation level of the built-in braking chopper and the minimum resistor that could be used depending on the input voltage.

Type	600V		
	Rmin for different input voltage (Ω)		
	500-525 VAC	550-600 VAC	660-690 VAC
SX-D6090-EF	4.9	5.7	6.5
SX-D6110-EF	4.9	5.7	6.5
SX-D6132-EF	4.9	5.7	6.5
SX-D6160-EF	4.9	5.7	6.5
SX-D6200-EF	2 x 4.9	2 x 5.7	2 x 6.5
SX-D6250-EF	2 x 4.9	2 x 5.7	2 x 6.5
SX-D6315-EF	2 x 4.9	2 x 5.7	2 x 6.5
SX-D6355-EF	2 x 4.9	2 x 5.7	2 x 6.5
SX-D6450-EF	3 x 4.9	3 x 5.7	3 x 5.7
SX-D6500-EF	3 x 4.9	3 x 5.7	3 x 5.7
SX-D6600-EF	4 x 4.9	4 x 5.7	4 x 5.7
SX-D6630-EF	4 x 4.9	4 x 5.7	4 x 5.7
SX-D6710-EF	6 x 4.9	6 x 5.7	6 x 5.7
SX-D6800-EF	6 x 4.9	6 x 5.7	6 x 5.7
SX-D6900-EF	6 x 4.9	6 x 5.7	6 x 5.7
SX-D61K0-EF	6 x 4.9	6 x 5.7	6 x 5.7

Supply voltage (VAC)	Built-in brake chopper trigger level (VDC)
500-525	860
550-600	1000
660-690	1150

⑦ Output coils

Output coils above SX-D6160-E should be order from factory as they should be installed inside of the cabinet

Voltage	Inverter model	Model	Rated current	Inductance	Rated Voltage	Max carrier	Max output frequency	Max temp
690V	SX-D6090-EF	473169 00	90A	0.1 mH	800V	6 kHz	200 Hz	40°C
	SX-D6110-EF	473170 00	146A	0.05 mH		6 kHz	200 Hz	
	SX-D6132-EF					6 kHz	200 Hz	
	SX-D6160-EF	473171 00	175A	0.05 mH		6 kHz	200 Hz	

⑧ Overshoot clamp

Only two types of overshoot clamps could be order for after mounting

Model	Inverter	Function
52163	SX-6090 to SX-6160	Together with the output coils, the overshoot clamp restricts the voltage and the dV/dt on the motor winding. Inverters must be ordered including the option DC+/DC- connectors.
52220	SX-6200 to SX-61K0	Together with the output coils, the overshoot clamp restricts the voltage and the dV/dt on the motor winding. Doesn't require the "DC+/DC-" option.

Computer software

Types	Model	Description	Installation
Software	CX-drive	Computer software	Configuration and monitoring software tool
	CX-One	Computer software	Configuration and monitoring software tool
	€Saver	Computer software	Software tool for Energy Saving calculation

ALL DIMENSIONS SHOWN ARE IN MILLIMETERS.
To convert millimeters into inches, multiply by 0.03937. To convert grams into ounces, multiply by 0.03527.

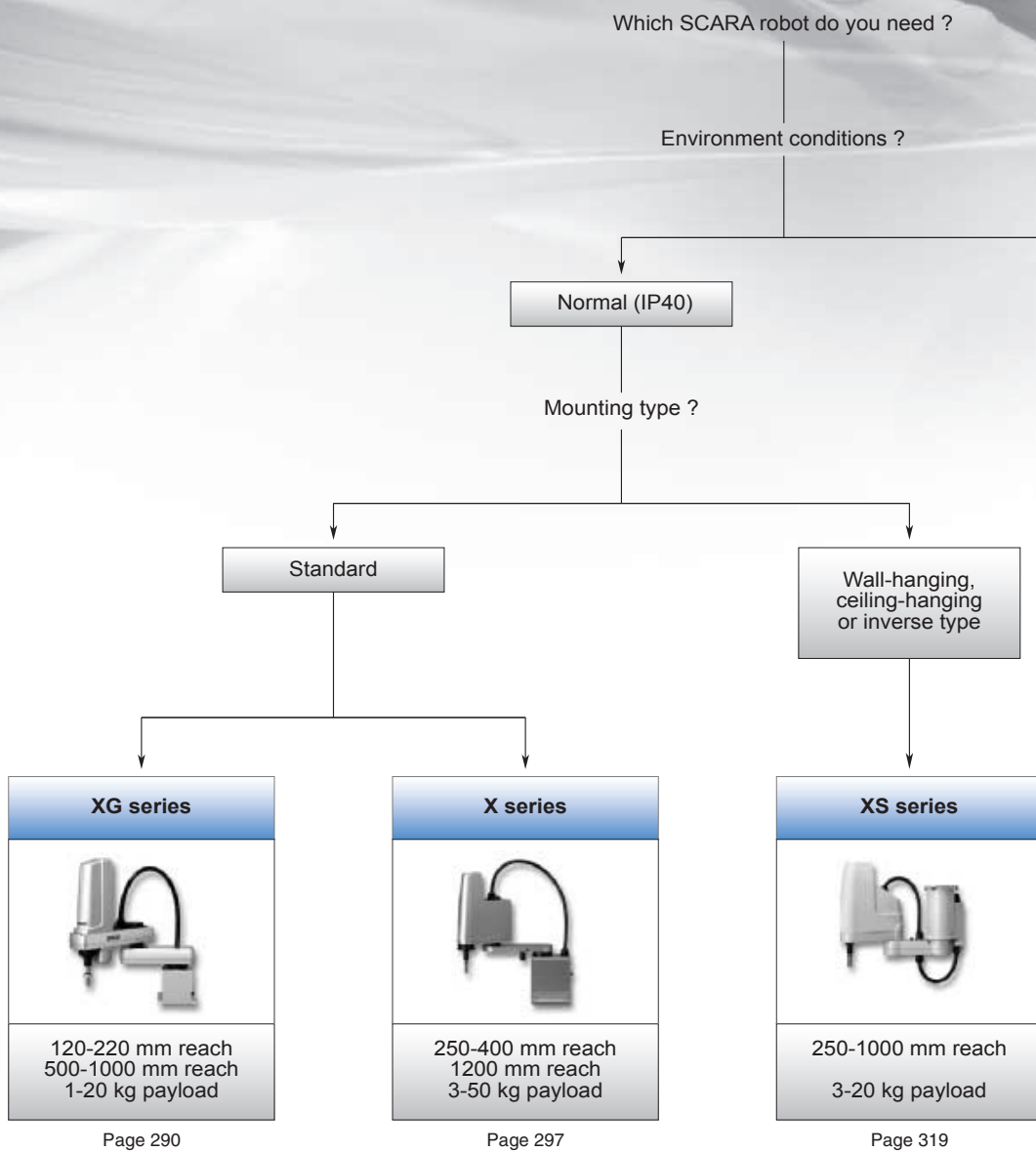
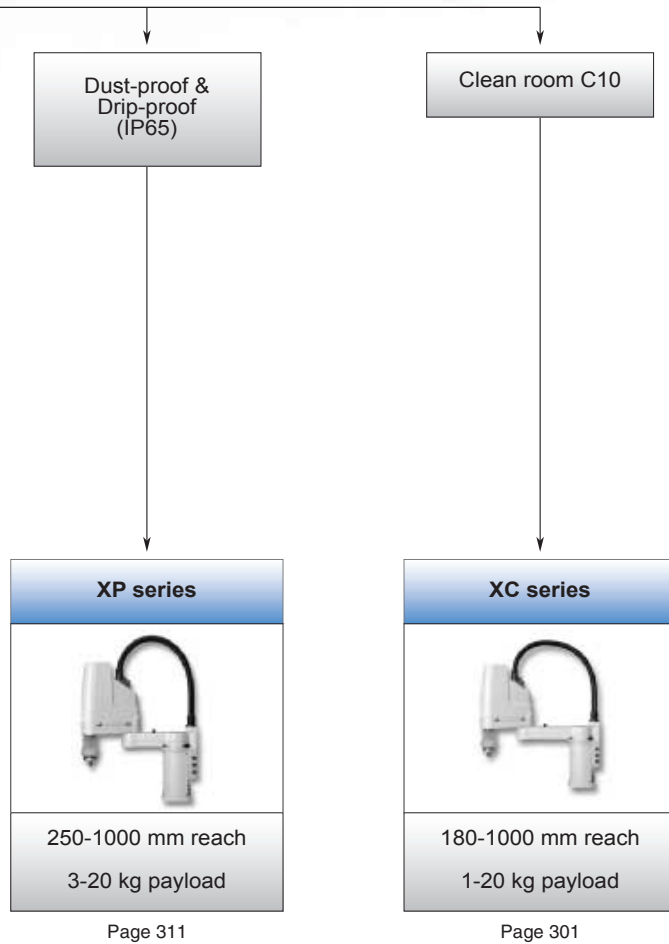

Table of contents

Selection table		276
SCARA robots	SCARA robot series	277



Selection table

Model	XG Series		X Series	
				
Typical environment	Normal conditions	Normal conditions	Normal conditions	Normal conditions
Reach	120 to 220 mm	500 to 1000 mm	250 to 400 mm	1200 mm
Max. Payload range	1 kg	10–20 Kg	3 kg	50 kg
Protection class	IP40	IP40	IP40	IP40
Mounting options	Standard	Standard	Standard	Standard
Page	286	290	297	297

Model	XS Series	XP Series	XC Series	
				
	Wall hanging type	Ceiling hanging type	Dust-proof type	Clean type
Typical environment	Normal conditions	Normal conditions	Food	Pharmaceutical
Reach	300 to 400 mm	400 to 1000 mm	250 to 1000 mm	180 to 1000 mm
Max. Payload range	3 kg	10–20 Kg	20 kg	20 kg
Protection class	IP40	IP40	IP65	Clean room C10
Mounting options	Standard; Inverse	Standard; Inverse	Standard	Standard
Page	319	321	311	301

Model	YRC - Robot controller
	
	One controller for all robot models
Applicable SCARA robot	The complete SCARA line-up
Drive method	PTP, arch motion, linear interpolation, circular interpolation
Coordinates	Cartesian coordinates, joint coordinates, User coordinates, Tool coordinates
Options	Parallel DIO board, DeviceNet, PROFIBUS and Ethernet connectivity, Vision board with 2 camera inputs, Conveyor tracking function
Programming tools	Teaching pendant and SCARA studio software
Page	278

SCARA robot series

SCARA robots for industrial applications:

- Higher reliability (no belts in XG series, no electronic parts in movement).
- Higher precision and speed.
- Minimum maintenance.
- Easier to use.
- Higher rigidity.
- Very compact design.



System configuration

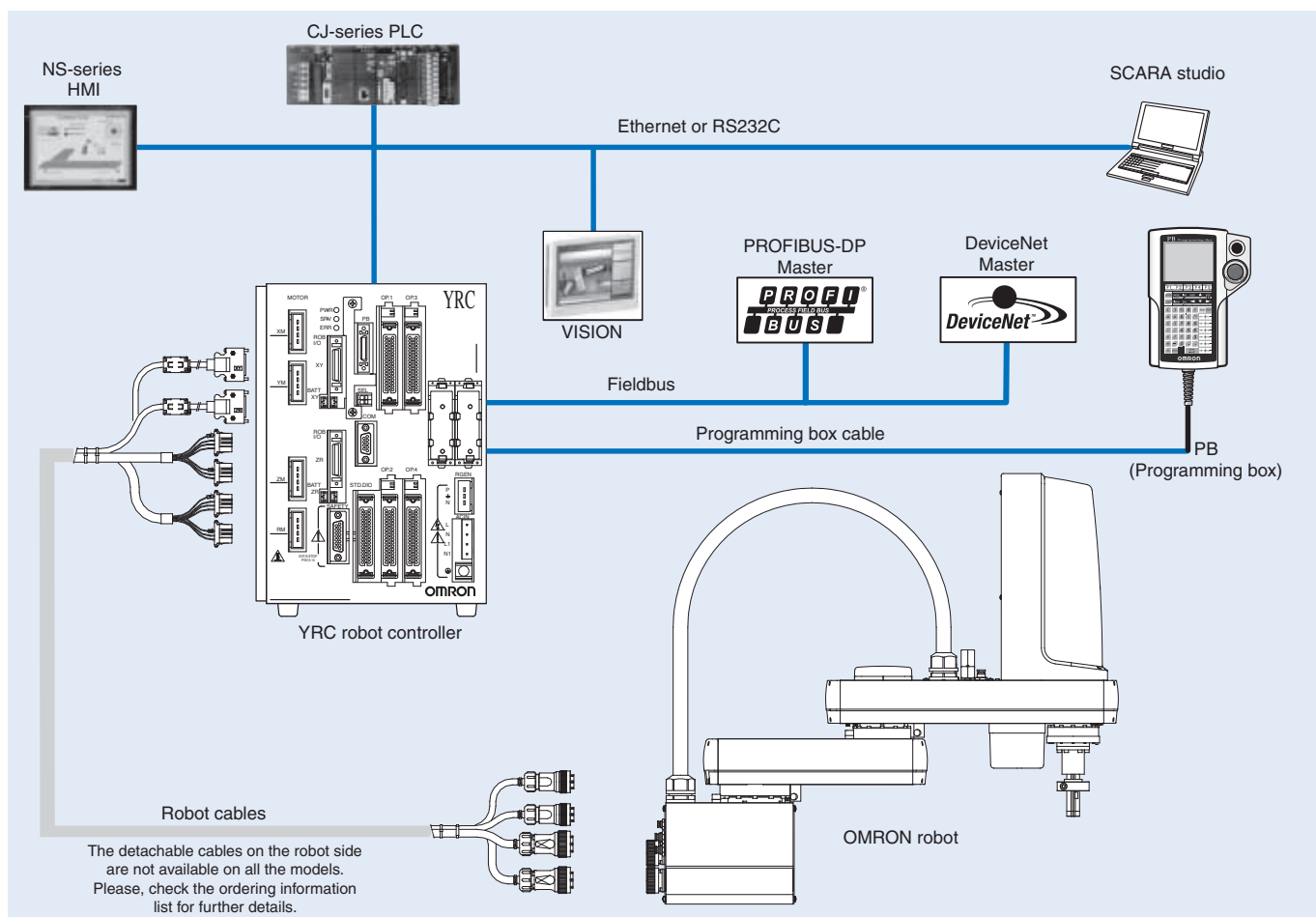

YRC Robot controller

Specifications

Item		Description		
YRC		YRC robot controller		
Basic specifications	Number of controllable axes	4 axes maximum (Control simultaneously: 4 axes)		
	Controllable robots	SCARA robots		
	Maximum power consumption	2500 VA		
	Capacity of the connected motor	1600 W		
	Dimensions (WxHxD)	180x250x235 mm		
Weight	6.5 kg			
Input power supply	Control power supply	Single phase AC200 to 230 V +/-10% maximum (50/60 Hz)		
	Motor power supply	Single phase AC200 to 230 V +/-10% maximum (50/60 Hz)		
Axis control	Drive method	AC full-digital software servo		
	Position detection method	Multi-turn resolver with data backup function, Magnetic linear scale		
	Operating method	PTP (Point to point), Linear interpolation, Circular interpolation, ARCH		
	Coordinate system	Joint coordinates, Cartesian coordinates		
	Position indication units	Pulses, mm (millimeters), deg (degrees)		
	Speed setting	1% to 100% (In units of 1%. However speed is in units of 0.01% during single-axis operation by DRIVE statement)		
	Acceleration setting	1. Automatic acceleration setting based on robot model type and end mass parameter 2. Setting based on acceleration and deceleration parameter (Setting by 1% unit)		
	Resolution	16384 P/rev, 1 micron		
	Origin search method	Incremental, absolute, semi-absolute		
Program	Program language	PSEUDO-BASIC (Conforming to JIS B8439 SLIM Language)		
	Multitasks	8 tasks maximum		
	Sequence program	1 program		
	Point-data input method	Manual data input (coordinate value input), Direct teaching, Teaching playback		
Memory	Memory capacity	364 KB (total capacity of program and points) (available program capacity during use of maximum number of points is 84 KB)		
	Programs	100 program (Max.) 9.999: maximum lines per program 98 KB: maximum capacity per program		
	Points	10,000 points: maximum number of points		
	Memory Backup battery	Lithium metallic battery (service life 4 years at a 0°C to 40°C)		
Internal flash memory	512 KB (ALL data only)			
External input/output	STD.DIO	I/O input	General input 16 points, dedicated input 10 points (NPN/PNP specifications selectable)	
		I/O output	General output 8 points, dedicated output 11 points	
	SAFETY	Emergency stop input (Relay contact), Service mode input (NPN/PNP specification is set according to STD.DIO setting)		
	Brake output	Relay contact		
	Origin sensor input	Connectable to DC 24 V normally-closed contact sensor		
	External communications	RS232C: 1CH D-SUB9 (female) RS422: 1CH (Dedicated PB)		
	Options	Slots	4	
		Type	Optional input/output (NPN/PNP): General input 24 points / General output 16 points	
			CC-Link: Dedicated input 16 points, Dedicated output 16 points, General input 96 points, General output 96 points (4 nodes occupied)	
			DeviceNet: Dedicated input 16 points, Dedicated output 16 points, General input 96 points, General output 96 points	
			Profibus: Dedicated input 16 points, Dedicated output 16 points, General input 96 points, General output 96 points	
			Ethernet: IEEE802.3 10Mbps (10BASE-T)	
			IVY: Camera input (2ch), camera trigger input, PC connection input	
Tracking: AB phase input, lighting trigger input, lighting power supply input/output				
Lighting control: lighting trigger input, lighting power supply input/output				
Options	Programming box	PB (with enable switch)		
	Support software for PC	SCARA STUDIO		
General specifications	Operating temperature	0°C to 40°C		
	Storage temperature	-10°C to 65°C		
	Operating humidity	35% to 85% RH (non-condensing)		
	Absolute backup battery	Lithium metallic battery 3.6 V 5400 mAh (2700 mAh x 2)		
	Absolute data backup period	1 year (in state with no power applied)		
	Noise immunity	IEC61000-4-4 Level 3		
Protective structure	IP10			

YRC-Optional Input/Output unit (PNP/NPN)

Item	Description
R6YACMA241 (NPN) R6YACMA242 (PNP)	Optional Input/Output unit
Optional Input/Output (NPN/PNP)	24 General purpose input, 16 General purpose output

YRC-DeviceNet slave unit

Item	Description	
R6YACDRT01	DeviceNet slave unit	
Applicable controllers	YRC	
Applicable DeviceNet specifications	Volume 1 Release 2.0 / Volume 2 Release 2.0	
Device Profile Name	Generic Device (device number 0)	
Number of occupied CH ^{*1}	Normal: Input/Output 24ch each, Compact: Input/Output 2ch each	
MAC ID setting	0 to 63	
Transmission speed setting	500 Kbps, 250 Kbps, 125 Kbps (set using DIP switch on board)	
DeviceNet I/O ^{*2}	Normal	General input 96 points, General output 96 points, Dedicated input 16 points, Dedicated output 16 points
	Compact	General input 16 points, General output 16 points, Dedicated input 16 points, Dedicated output 16 points
Parallel external I/O	The master module and up to four ports can be controlled regardless of the robot program by using the pseudoserialization function	
Network length	Overall length ^{*3}	100 m/500 Kbps, 250 m/250 Kbps, 500 m/125 Kbps
	Branch length / Overall branch length	6 m max./39 m max., 6 m max./78 m max., 6 m max./156 m max.
Monitor LED	MS (Module Status), NS (Network Status)	

*1 Use the robot parameter to select Normal or Compact.

*2 Controller I/O are updated every 10ms.

*3 These values apply when a thick cable is used. The distance is less when a fine cable is used or when thick and fine cables are mixed in use.

YRC-Profibus slave unit

Item	Description
R6YACPR01	Profibus slave unit
Applicable controllers	YRC
Communication profile	Profibus-DP slave
Number of occupied nodes	1 node
Setting of station address	1 to 99 (set using Rotary switch on board)
Setting of communication speed	9.6 Kbps, 19.2 Kbps, 93.75 Kbps, 187.5 Kbps, 500 Kbps, 1.5 Mbps, 3 Mbps, 6 Mbps, 12 Mbps (automatic recognition)
Profibus I/O ^{*1}	General input 96 points, General output 96 points, Dedicated input 16 points, Dedicated output 16 points
Parallel external I/O	The master module and up to four ports can be controlled regardless of the robot program by using the pseudoserialization function
Overall length	100 m/3 M-6 M-12 Mbps, 200 m/1.5 Mbps, 400 m/500 Kbps, 1000 m/187.5 Kbps, 1200 m/9.6 K- 19.2 K-93.75 Kbps
Monitor LED	RUN, ERR, SD, RD, DATA-EX

*1 The shortest I/O update interval of the controller is 10 ms but the actual I/O update time varies depending on the update time with the master station.

YRC-Ethernet unit

Item	Description
R6YACETN01	Ethernet unit
Applicable controllers	YRC
Network specification	As specified for Ethernet (IEEE802.3)
Connector specification	RJ-45 connector (8-pole modular connector) 1 port
Baud rate	10 Mbps (10BASE-T)
Communication mode	Half Duplex (Half-duplex)
Network protocol	Application layer: TELNET / Transport layer: TCP / IP Network layer: IP, ICMP, ARP / Data link layer: CSMA / CD Physical layer: 10BASE-T
Number of simultaneous log inputs	1
Setting of IP address, etc.	Set from PB
Monitor LED	Run, Collision, Link, Transmit, Receive

YRC-VISION board basic specifications

Item	Description	
R6YACVI01	VISION board	
Basic specifications	Applicable controller	YRC
	Pixels	640 (H) x 480 (V) (300,000 pixels, VGA)
	Settable part types	40 part types
	Connectable cameras	Maximum 2 units ^{*1}
	Camera types	Double speed compatible analog camera
	Memory	128 MB SDRAM, 256 MB miniSD card
	External I/F	Ethernet (100BASE-TX)
Search method	Edge search (Correlative edge filter, Sobel filter)	
Image input	Trigger	S/W trigger, H/W trigger, Camera internal synch
	External trigger input	2 points
Functions	Search function	Position offset, Auto registry of point data
Setup support functions	Calibration, image storage function ^{*2} (all images / specified image)	

*1 If connecting 2 units, then must be the same model.

*2 Requires Windows PC.

Accessories for YRC-VISION board

Item	Description
R6YACS1	CCD CAMERA
R6YACCV003	Camera cable 3.5 m
R6YACCV006	Camera cable 6 m
R6YACCV009	Camera cable 9.5 m (3.5 m + 6 m)
R6YACLE008	Lens 8 mm
R6YACLE012	Lens 12 mm
R6YACLE016	Lens 16 mm
R6YACLE025	Lens 25 mm
R6YACLR005	Close up ring 0.5 mm
R6YACLR010	Close up ring 1.0 mm
R6YACLR020	Close up ring 2.0 mm
R6YACLR050	Close up ring 5.0 mm

YRC-Tracking board basic specifications

Item	Description		
R6YACTR01	Tracking board		
Basic specifications	Lighting control section	Applicable controller	YRC
		Number of lighting connected units	Up to 2 units
		Light adjusting system	PWM control (0 to 100%) (Cycle 60 KHz) Stroboscopic light (10 to 33000 μs)
		Trigger	S/W trigger, H/W trigger
		External trigger input	2 points
		Lighting power input	12 VDC or 24 VDC (Supplied from outside commonly to 2 channels)
		Lighting output	When DC 12 V is supplied: Less than 30 W with 2 channels totaled When DC 24 V is supplied: Less than 60 W with 2 channels totaled
	Pulse input section	Number of encoder connected units	Up to 2 units
		Encoder power source	DC 5 V (Less than 500 mA with 2 channels totaled) (Supplied from controller)
		Applicable encoder	Line driver equivalent to 26LS31 / 26C31 (Conforming to RS422)
		Input phase	A, A, B, B, Z, Z
		Maximum response frequency	2 MHz
		Counter / Step-up multiplication	0 to 65535 / Double, quadruple
		Other	Provided with broken wire detect function

Note: The tracking board is required when using the tracking function.

Accessories for YRC-Tracking board

Item	Description
R6YACCR005	Encoder cable for tracking 10m

YRC-Lighting control board basic specifications

Item	Description	
R6YACLI01	Lighting control board	
Basic specifications	Applicable controller	YRC
	Number of lighting connected units	Up to 2 units
	Light adjusting system	PWM control (0 to 100%) (Cycle 60KHz) Stroboscopic light (10 to 33000us)
	Trigger	S/W trigger, H/W trigger
	External trigger input	2 points
	Lighting power input	12VDC or 24VDC (Supplied from outside commonly to 2 channels)
Lighting output	When DC12V is supplied: Less than 30W with 2 channels totaled When DC24V is supplied: Less than 60W with 2 channels totaled	

Accessories for YRC-PB (Programming box)

Item	Description
R6YACPB005E	Programming box cable 5m
R6YACPB012E	Programming box cable 12m

Accessories for YRC-SCARA studio software

Item	Description
R6YACSSC1	Support software SCARA studio
R6YACCC005	Communication cable 9-9 pin

YRC-Nomenclature

Connector names

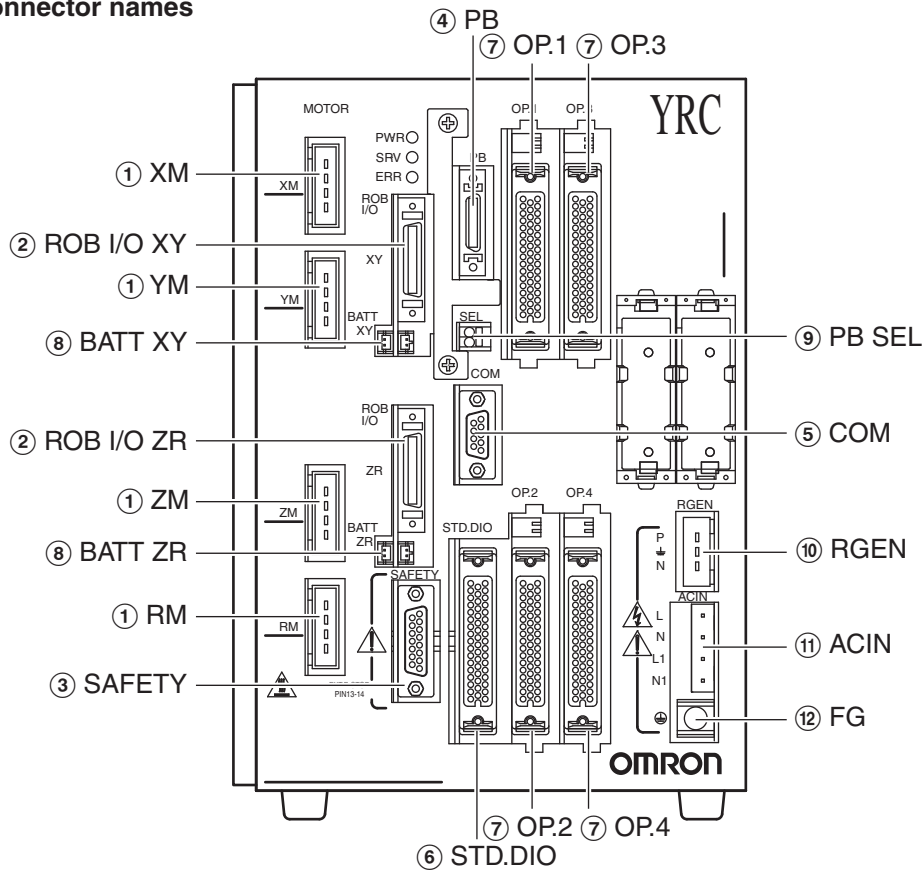

	Connector name	Function
①	XM/YM/ZM/RM	Connectors for servomotor drive
②	ROB I/O [XY/ZR]	Connectors for servomotor feedback and sensor signals
③	SAFETY	Input/output connector for safety function such as emergency stop
④	PB	Connector for PB
⑤	COM	RS-232C interface connector.
⑥	STD.DIO	Connector for dedicated input/output and standard generalpurpose input/output
⑦	OP.1, 2, 3, 4	Conectors attached to optional expansion I/O boards
⑧	BATT [XY/ZR]	Battery connector for absolute backup
⑨	PB SEL	PB selector switch contact
⑩	RGEN [P/⏏/N]	Connector for regenerative unit
⑪	AC IN [L/N/L1/N1]	Terminal block for power cable. Use ring-tongue terminals to make connections.
⑫	FG	Ground terminal (⏏). Provide Class D grounding (100 ohms or less).

Dimensions

Standard YRC

Top view

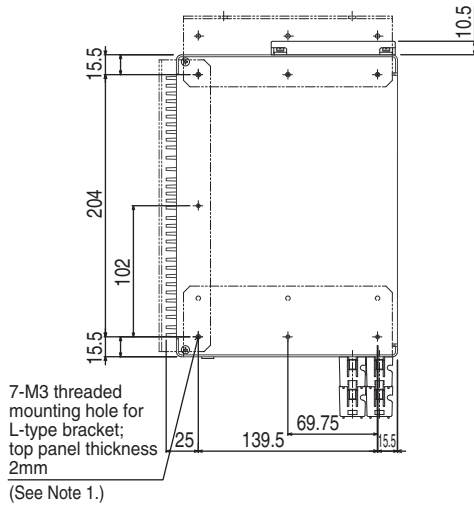

Front view

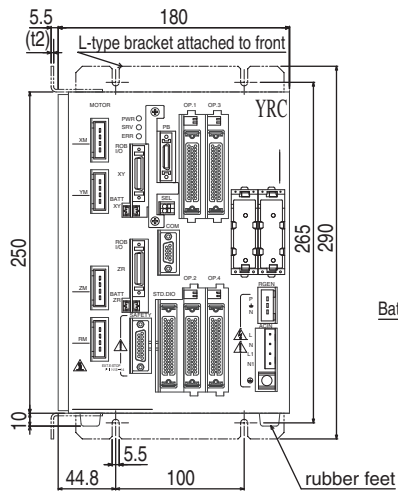

Side view

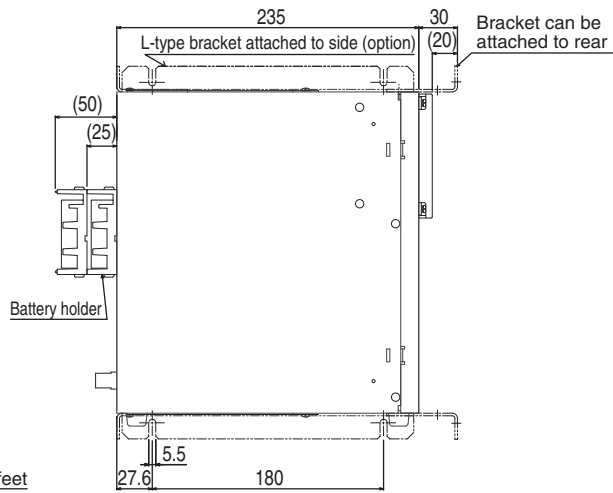

Rear view

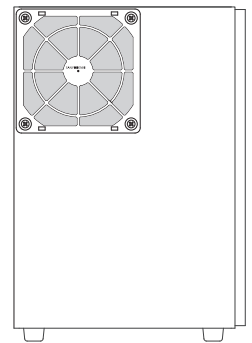

Bottom view

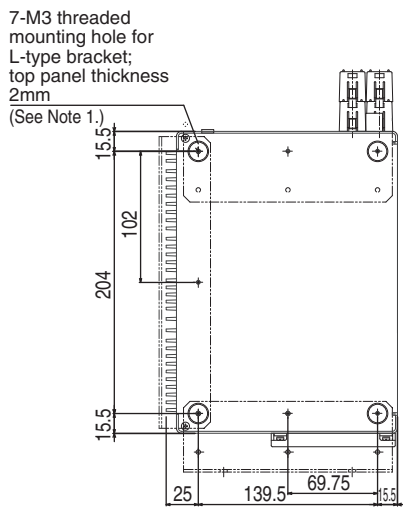

Note 1: When installing this controller using the supplied L-type brackets, remove the rubber feet on the bottom plate.

Industrial robots

YRC with RGU2 option installed

Top view

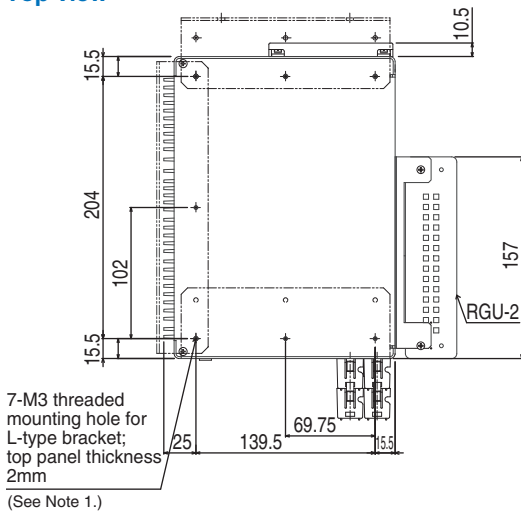

Front view

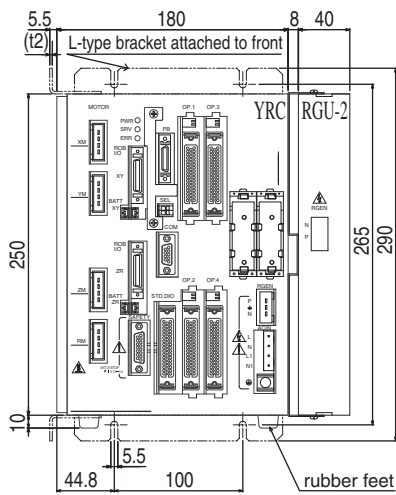

Side view

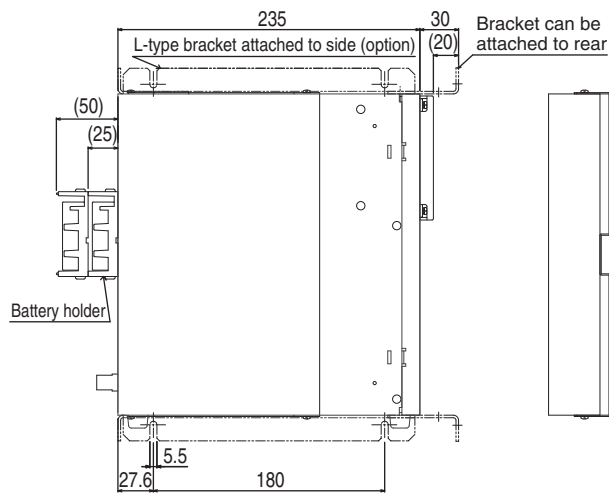

Rear view

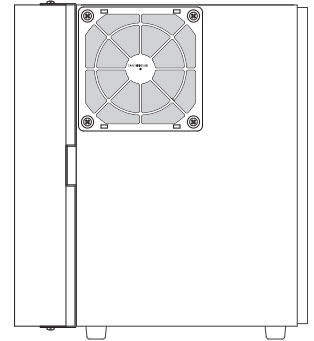

Bottom view

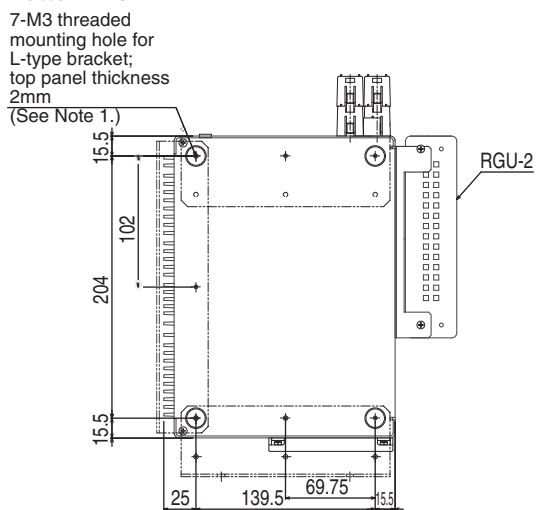

YRC with RGU3 option installed

Top view

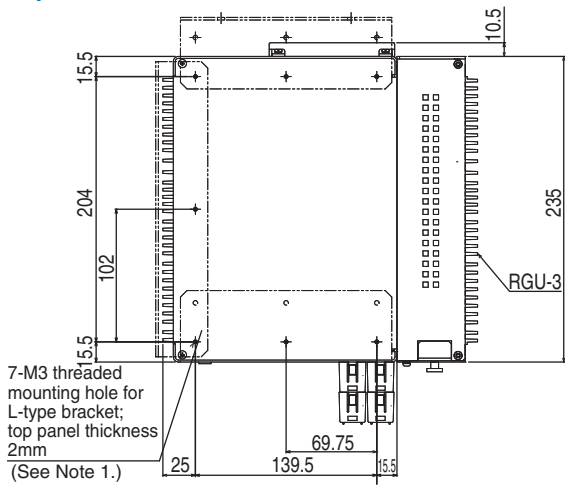

Front view

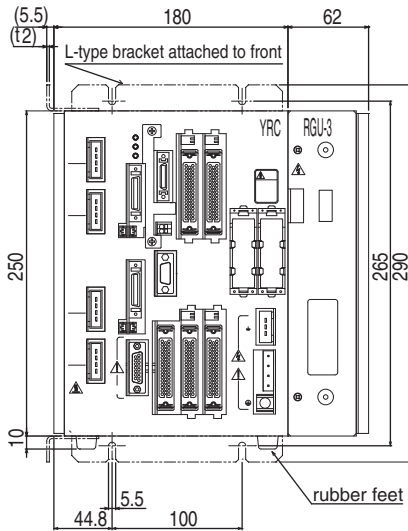

Side view

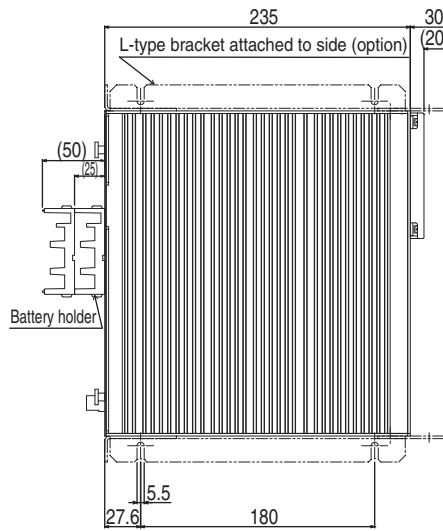

Rear view

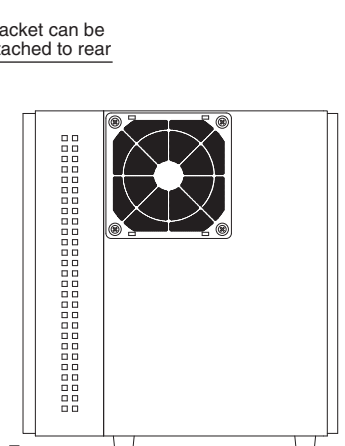

Bottom view

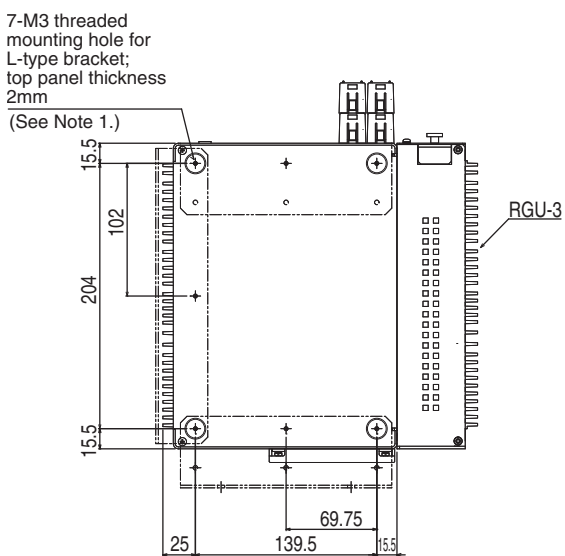

R6YXG120 TINY SERIES

Specifications

	X axis	Y axis	Z axis	R axis	
Reach (mm)	120				
Maximum payload (kg)	1				
Repeatability ^{*1} (XYZ:mm) (R:°)	+/-0.005		+/-0.01	+/-0.004	
Axis specifications	Arm length (mm)	45	75	50	
	Rotation range (°)	+/-125	+/-145	----	
Deceleration mechanism	Speed reducer	Harmonic drive	Harmonic drive	Ball screw	
	Transmission method	Motor to speed reducer	Direct-coupled		
		Speed reducer to output	Direct-coupled		
AC servo motor output (W)	30	30	30	30	
Maximum speed (XYZ:m/sec) (R:°/sec)	3.3		0.9	1700	
Standard cycle time: with 0.1kg payload ^{*2} (sec)	0.33				
R axis allowable moment inertia ^{*3} (kgm ²)	0.01				
User wiring (sq x pcs)	0.1 x 8				
User tubing (Outer diameter)	Ø4 x 2				
Movement limit setting	1.Soft limit 2.Mechanical stopper (X, Y, Z axis)				
Robot cable length (m)	Standard: 2 Option: 3.5, 5, 10				
Weight (kg) (Robot cable not included) ^{*4}	3.9				
Robot cable weight	0.9kg (2m) 1.5kg (3.5m) 2.1kg (5m) 4.2kg (10m)				

- *1 This is the value at a constant ambient temperature. (X,Y axes)
- *2 When moving 25mm in vertical direction and 100mm in horizontal direction reciprocally.
- *3 There are limits to the setting of the acceleration coefficient.
- *4 The overall weight of the robot is the total of the robot itself and the robot cable.

Controller

Controller	Power consumption (VA)	Operating method
YRC	300	Programming / I/O point trace / Remote command / Operation using RS-232C communication

Ordering information

Description	Model
SCARA Reach: 120mm, Vertical Stroke: 50mm, Max. payload: 1kg.	R6YXG12050YRC

Dimensions

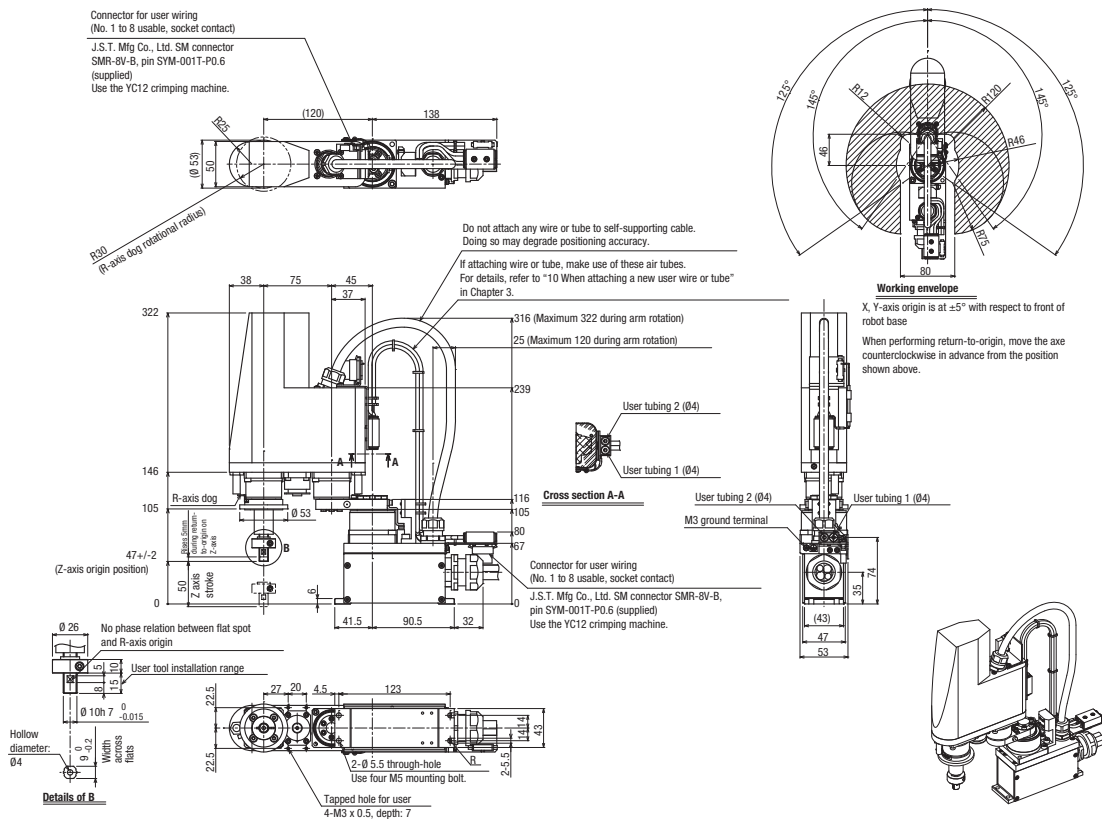

R6YXG220 TINY SERIES

Specifications

		X axis	Y axis	Z axis	R axis
Reach (mm)		220			
Maximum payload (kg)		1			
Repeatability ^{*1} (XYZ:mm) (R:°)		+/-0.01		+/-0.01	+/-0.004
Axis specifications	Arm length (mm)	111	109	100	----
	Rotation range (°)	+/-120	+/-140	----	+/-360
Deceleration mechanism	Speed reducer	Harmonic drive	Harmonic drive	Ball screw	Harmonic drive
	Transmission method	Motor to speed reducer	Direct-coupled		
		Speed reducer to output	Direct-coupled		
AC servo motor output (W)		50	30	30	30
Maximum speed (XYZ:m/sec) (R:°/sec)		3.4		0.7	1700
Standard cycle time: with 0.1kg payload ^{*2} (sec)		0.42			
R axis allowable moment inertia ^{*3} (kgm ²)		0.01			
User wiring (sq x pcs)		0.1 x 6			
User tubing (Outer diameter)		Ø3 x 2			
Movement limit setting		1.Soft limit 2.Mechanical stopper (X, Y, Z axis)			
Robot cable length (m)		Standard: 3.5 Option: 5, 10			
Weight (kg) (Robot cable not included) ^{*4}		5.5			
Robot cable weight		1.5kg (3.5m) 2.1kg (5m) 4.2kg (10m)			

- *1 This is the value at a constant ambient temperature. (X,Y axes)
- *2 When moving 25mm in vertical direction and 100mm in horizontal direction reciprocally.
- *3 There are limits to the setting of the acceleration coefficient.
- *4 The overall weight of the robot is the total of the robot itself and the robot cable.

Controller

Controller	Power consumption (VA)	Operating method
YRC	500	Programming / I/O point trace / Remote command / Operation using RS-232C communication

Ordering information

Description	Model
SCARA Reach: 220mm, Vertical Stroke: 100mm, Max. payload: 1kg.	R6YXG220100YRC

Dimensions

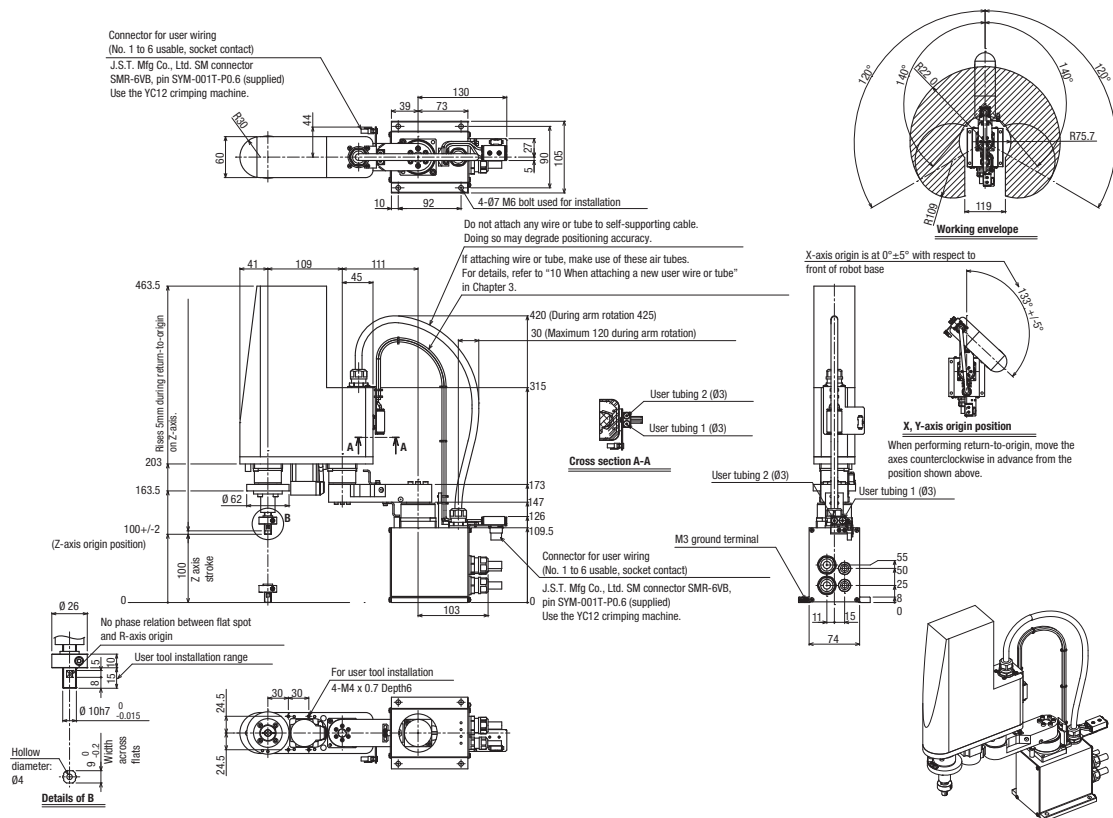

Industrial robots

R6YXG500 XG SERIES

Specifications

	X axis	Y axis	Z axis	R axis	
Reach (mm)	500				
Maximum payload (kg)	10				
Repeatability ^{*1} (XYZ:mm) (R:°)	+/-0.01		+/-0.01	+/-0.004	
Axis specifications	Arm length (mm)	200	300	200	
	Rotation range (°)	+/-130	+/-145	----	
Deceleration mechanism	Speed reducer	Harmonic drive	Harmonic drive	Ball screw	
	Transmission method	Motor to speed reducer	Direct-coupled		
		Speed reducer to output	Direct-coupled		
AC servo motor output (W)	400	200	200	200	
Maximum speed (XYZ:m/sec) (R:°/sec)	7.6		2.3	1.7	
Standard cycle time: with 2kg payload ^{*2} (sec)	0.45				
R axis allowable moment inertia ^{*3} (kgm ²)	0.30				
User wiring (sq x pcs)	0.2 x 20				
User tubing (Outer diameter)	Ø6 x 3				
Movement limit setting	1.Soft limit 2.Mechanical stopper (X, Y, Z axis)				
Robot cable length (m)	Standard: 3.5 Option: 5, 10				
Weight (kg) (Excluding robot cable)	30				

*1 This is the value at a constant ambient temperature. (X,Y axes)
 *2 When moving 25mm in vertical direction and 300mm in horizontal direction reciprocally.
 *3 There are limits to the setting of the acceleration coefficient.

Controller

Controller	Power consumption (VA)	Operating method
YRC	1700	Programming / I/O point trace / Remote command / Operation using RS-232C communication

Ordering information

Description	Model
SCARA Reach: 500mm, Vertical Stroke: 200mm, Max. payload: 10kg.	R6YXG500200YRC
SCARA Reach: 500mm, Vertical Stroke: 300mm, Max. payload: 10kg.	R6YXG500300YRC

Dimensions

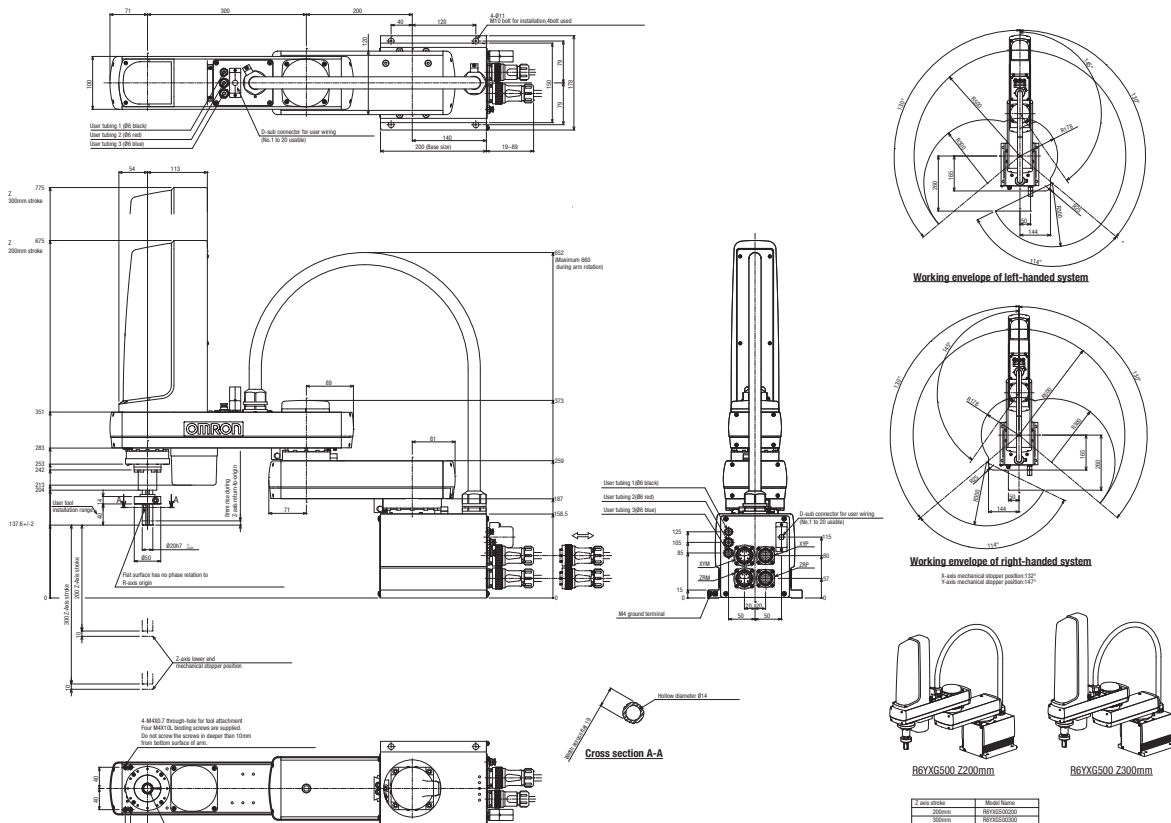

R6YXG600 XG SERIES

Specifications

		X axis	Y axis	Z axis	R axis
Reach (mm)		600			
Maximum payload (kg)		10			
Repeatability ^{*1} (XYZ:mm) (R:°)		+/-0.01		+/-0.01	+/-0.004
Axis specifications	Arm length (mm)	300	300	200	300
	Rotation range (°)	+/-130	+/-145	----	+/-360
Deceleration mechanism	Speed reducer	Harmonic drive	Harmonic drive	Ball screw	Harmonic drive
	Transmission method	Motor to speed reducer	Direct-coupled		
		Speed reducer to output	Direct-coupled		
AC servo motor output (W)		400	200	200	200
Maximum speed (XYZ:m/sec) (R:°/sec)		8.4		2.3	1.7
Standard cycle time: with 2kg payload ^{*2} (sec)		0.46			
R axis allowable moment inertia ^{*3} (kgm ²)		0.30			
User wiring (sq x pcs)		0.2 x 20			
User tubing (Outer diameter)		Ø6 x 3			
Movement limit setting		1.Soft limit 2.Mechanical stopper (X, Y, Z axis)			
Robot cable length (m)		Standard: 3.5 Option: 5, 10			
Weight (kg) (Excluding robot cable)		31			

- *1 This is the value at a constant ambient temperature. (X,Y axes)
- *2 When moving 25mm in vertical direction and 300mm in horizontal direction reciprocally.
- *3 There are limits to the setting of the acceleration coefficient.

Controller

Controller	Power consumption (VA)	Operating method
YRC	1700	Programming / I/O point trace / Remote command / Operation using RS-232C communication

Ordering information

Description	Model
SCARA Reach: 600mm, Vertical Stroke: 200mm, Max. payload: 10kg.	R6YXG600200YRC
SCARA Reach: 600mm, Vertical Stroke: 300mm, Max. payload: 10kg.	R6YXG600300YRC

Dimensions

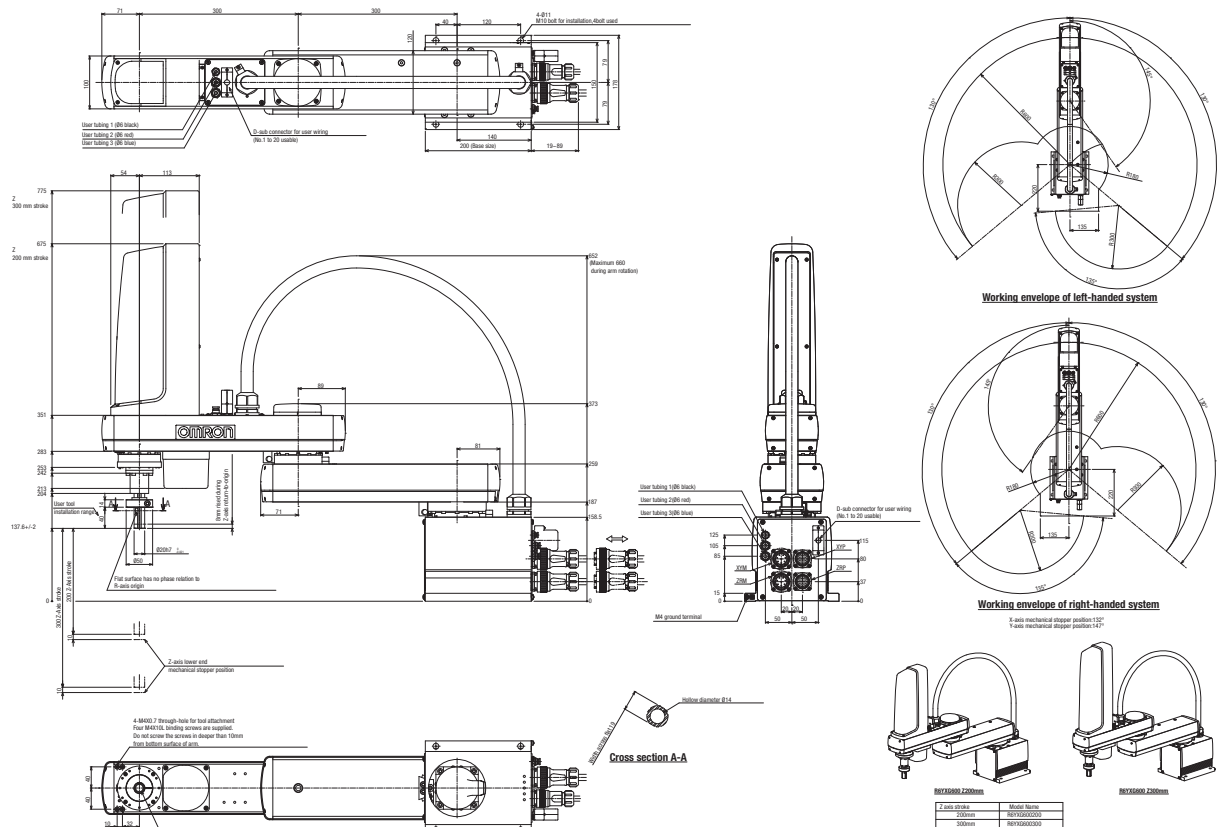

Industrial robots

R6YXGH600 XG SERIES

Specifications

		X axis	Y axis	Z axis	R axis
Reach (mm)		600			
Maximum payload (kg)		20			
Repeatability ^{*1} (XYZ:mm) (R:°)		+/-0.02		+/-0.01	+/-0.004
Axis specifications	Arm length (mm)	200	400	200	400
	Rotation range (°)	+/-130	+/-150	----	+/-360
Deceleration mechanism	Speed reducer	Harmonic drive	Harmonic drive	Ball screw	Harmonic drive
	Transmission method	Motor to speed reducer	Direct-coupled		
		Speed reducer to output	Direct-coupled		
AC servo motor output (W)		750	400	400	200
Maximum speed (XYZ:m/sec) (R:°/sec)		7.7		2.3	1.7
Standard cycle time: with 2kg payload ^{*2} (sec)		0.47			
R axis allowable moment inertia ^{*3} (kgm ²)		1			
User wiring (sq x pcs)		0.2 x 20			
User tubing (Outer diameter)		Ø6 x 3			
Movement limit setting		1.Soft limit 2.Mechanical stopper (X, Y, Z axis)			
Robot cable length (m)		Standard: 3.5 Option: 5, 10			
Weight (kg) (Excluding robot cable)		Z axis 200mm: 48, Z axis 400mm: 50			

- *1 This is the value at a constant ambient temperature. (X,Y axes)
- *2 When moving 25mm in vertical direction and 300mm in horizontal direction reciprocally.
- *3 There are limits to the setting of the acceleration coefficient.

Controller

Controller	Power consumption (VA)	Operating method
YRC	2500	Programming / I/O point trace / Remote command / Operation using RS-232C communication

Ordering information

Description	Model
SCARA Reach: 600mm, Vertical Stroke: 200mm, Max. payload: 20kg.	R6YXGH600200YRC
SCARA Reach: 600mm, Vertical Stroke: 400mm, Max. payload: 20kg.	R6YXGH600400YRC

Dimensions

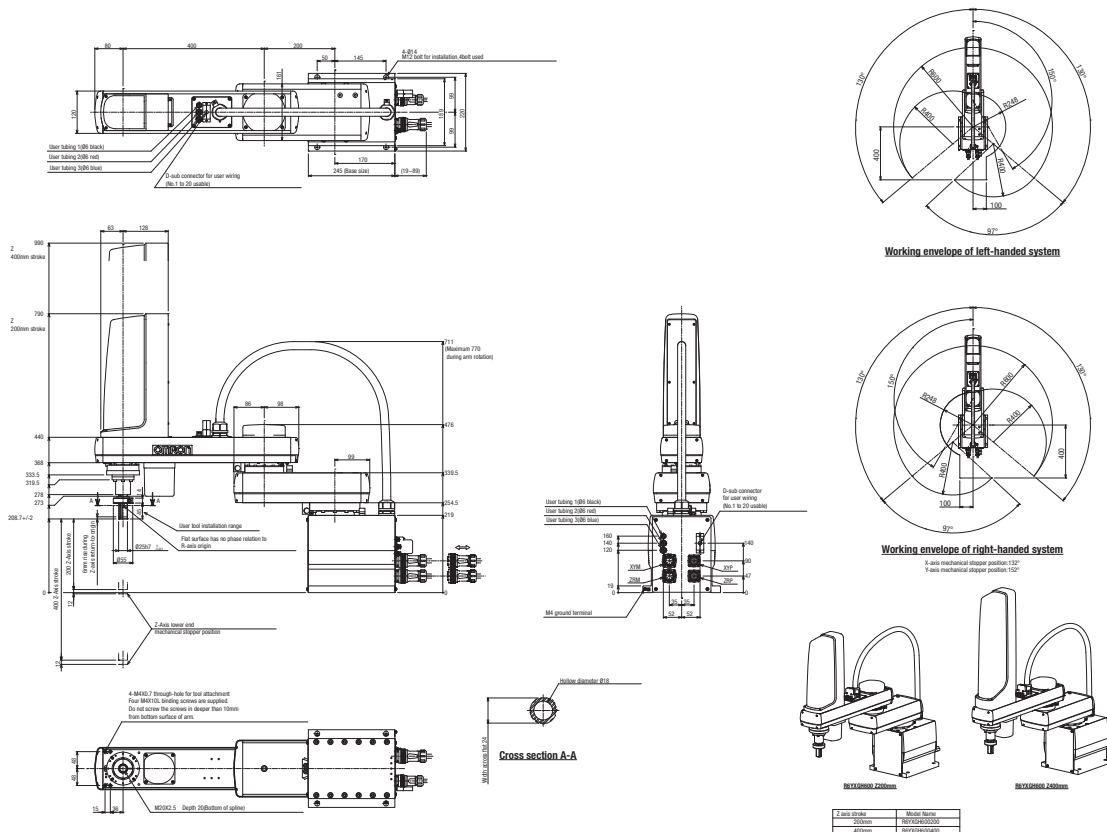

R6YXG700 XG SERIES

Specifications

		X axis	Y axis	Z axis	R axis
Reach (mm)		700			
Maximum payload (kg)		20			
Repeatability ^{*1} (XYZ:mm) (R:°)		+/-0.02		+/-0.01	+/-0.004
Axis specifications	Arm length (mm)	300	400	200	400
	Rotation range (°)	+/-130	+/-150	----	+/-360
Deceleration mechanism	Speed reducer	Harmonic drive	Harmonic drive	Ball screw	Harmonic drive
	Transmission method	Motor to speed reducer	Direct-coupled		
		Speed reducer to output	Direct-coupled		
AC servo motor output (W)		750	400	400	200
Maximum speed (XYZ:m/sec) (R:°/sec)		8.4		2.3	1.7
Standard cycle time: with 2kg payload ^{*2} (sec)		0.42			
R axis allowable moment inertia ^{*3} (kgm ²)		1			
User wiring (sq x pcs)		0.2 x 20			
User tubing (Outer diameter)		Ø6 x 3			
Movement limit setting		1.Soft limit 2.Mechanical stopper (X, Y, Z axis)			
Robot cable length (m)		Standard: 3.5 Option: 5, 10			
Weight (kg) (Excluding robot cable)		Z axis 200mm: 50, Z axis 400mm: 52			

- *1 This is the value at a constant ambient temperature. (X,Y axes)
- *2 When moving 25mm in vertical direction and 300mm in horizontal direction reciprocally.
- *3 There are limits to the setting of the acceleration coefficient.

Controller

Controller	Power consumption (VA)	Operating method
YRC	2500	Programming / I/O point trace / Remote command / Operation using RS-232C communication

Ordering information

Description	Model
SCARA Reach: 700mm, Vertical Stroke: 200mm, Max. payload: 20kg.	R6YXG700200YRC
SCARA Reach: 700mm, Vertical Stroke: 400mm, Max. payload: 20kg.	R6YXG700400YRC

Dimensions

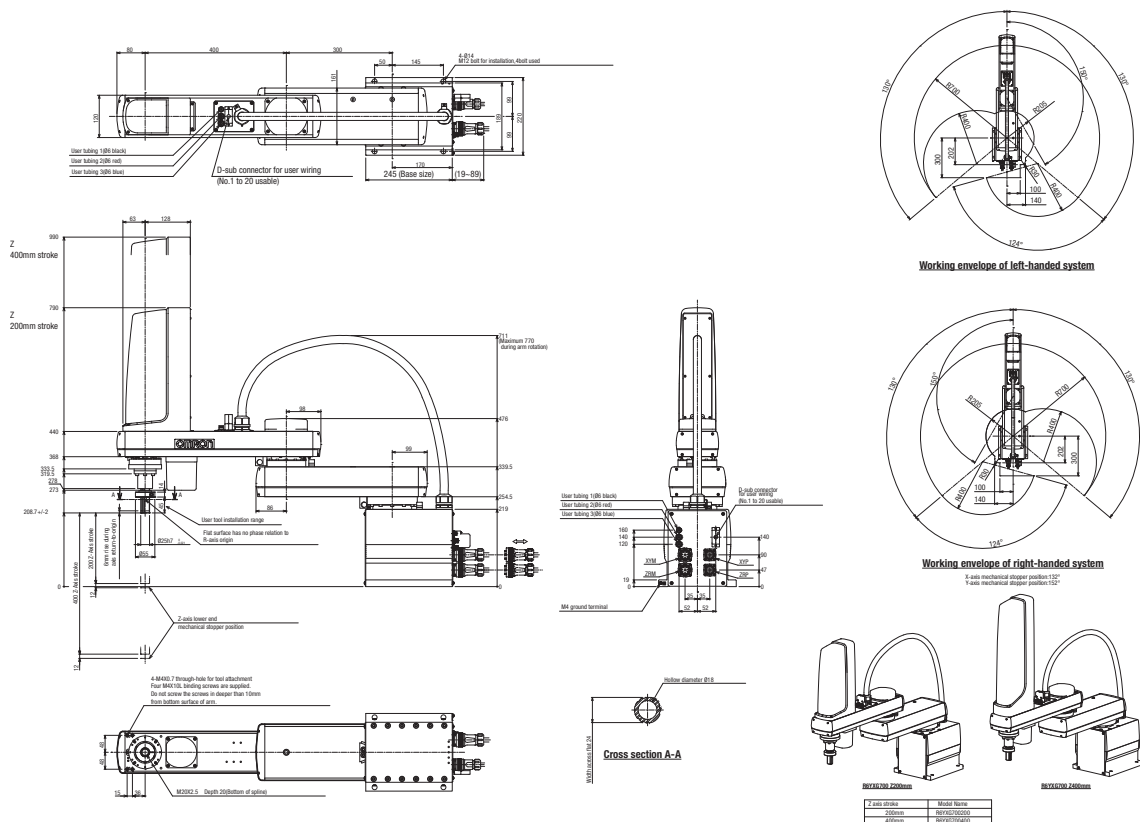

R6YXG800 XG SERIES

Specifications

	X axis	Y axis	Z axis	R axis
Reach (mm)	800			
Maximum payload (kg)	20			
Repeatability ^{*1} (XYZ:mm) (R:°)	+/-0.02		+/-0.01	+/-0.004
Axis specifications	Arm length (mm)	400	200	400
	Rotation range (°)	+/-130	+/-150	----
Deceleration mechanism	Speed reducer	Harmonic drive	Harmonic drive	Ball screw
	Transmission method	Motor to speed reducer	Direct-coupled	Direct-coupled
AC servo motor output (W)	750	400	400	200
Maximum speed (XYZ:m/sec) (R:°/sec)	9.2		2.3	1.7
Standard cycle time: with 2kg payload ^{*2} (sec)	0.48			
R axis allowable moment inertia ^{*3} (kgm ²)	1			
User wiring (sq x pcs)	0.2 x 20			
User tubing (Outer diameter)	Ø6 x 3			
Movement limit setting	1.Soft limit 2.Mechanical stopper (X, Y, Z axis)			
Robot cable length (m)	Standard: 3.5 Option: 5, 10			
Weight (kg) (Excluding robot cable)	Z axis 200mm: 52, Z axis 400mm: 54			

*1 This is the value at a constant ambient temperature. (X,Y axes)
 *2 When moving 25mm in vertical direction and 300mm in horizontal direction reciprocally.
 *3 There are limits to the setting of the acceleration coefficient.

Controller

Controller	Power consumption (VA)	Operating method
YRC	2500	Programming / I/O point trace / Remote command / Operation using RS-232C communication

Ordering information

Description	Model
SCARA Reach: 800mm, Vertical Stroke: 200mm, Max. payload: 20kg.	R6YXG800200YRC
SCARA Reach: 800mm, Vertical Stroke: 400mm, Max. payload: 20kg.	R6YXG800400YRC

Dimensions

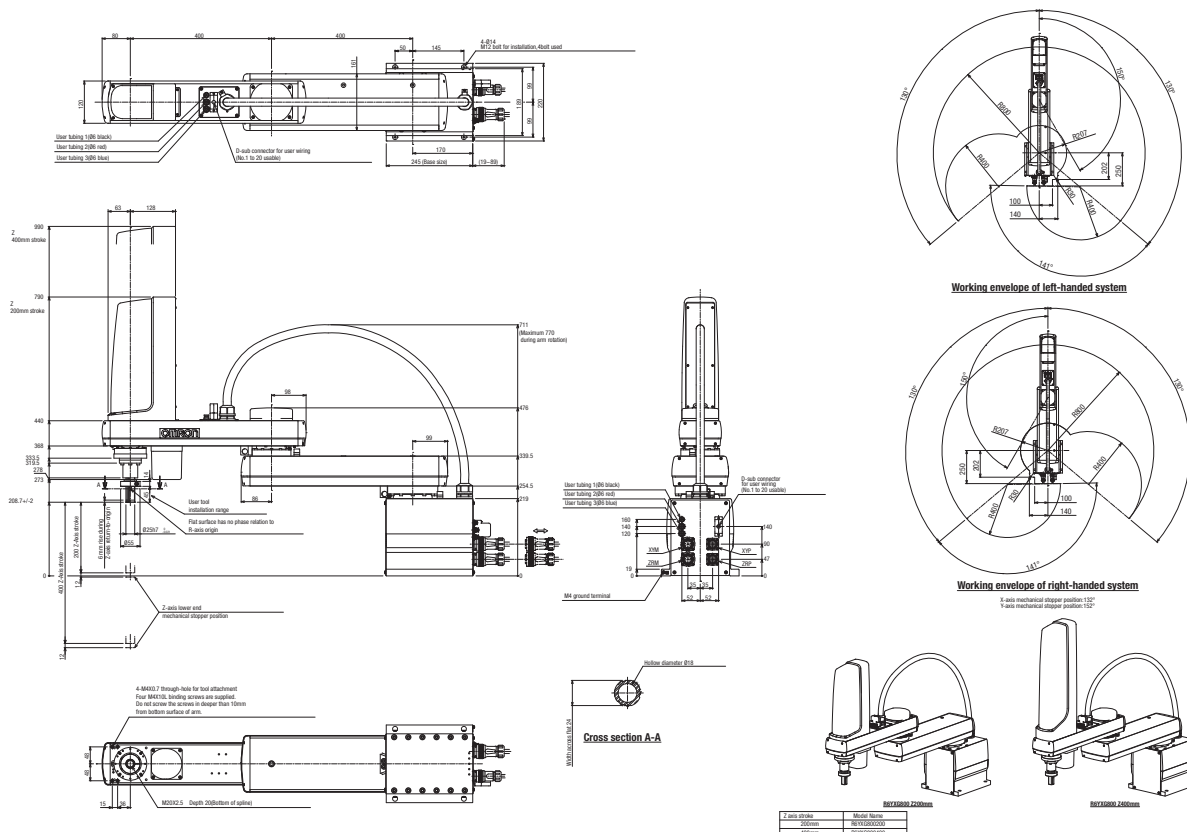

R6YXG900 XG SERIES

Specifications

		X axis	Y axis	Z axis	R axis
Reach (mm)		900			
Maximum payload (kg)		20			
Repeatability ^{*1} (XYZ:mm) (R:°)		+/-0.02		+/-0.01	+/-0.004
Axis specifications	Arm length (mm)	500	400	200	400
	Rotation range (°)	+/-130	+/-150	----	+/-360
Deceleration mechanism	Speed reducer	Harmonic drive	Harmonic drive	Ball screw	Harmonic drive
	Transmission method	Motor to speed reducer	Direct-coupled		
		Speed reducer to output	Direct-coupled		
AC servo motor output (W)		750	400	400	200
Maximum speed (XYZ:m/sec) (R:°/sec)		9.9		2.3	1.7
Standard cycle time: with 2kg payload ^{*2} (sec)		0.49			
R axis allowable moment inertia ^{*3} (kgm ²)		1			
User wiring (sq x pcs)		0.2 x 20			
User tubing (Outer diameter)		Ø6 x 3			
Movement limit setting		1.Soft limit 2.Mechanical stopper (X, Y, Z axis)			
Robot cable length (m)		Standard: 3.5 Option: 5, 10			
Weight (kg) (Excluding robot cable)		Z axis 200mm: 54, Z axis 400mm: 56			

- *1 This is the value at a constant ambient temperature. (X,Y axes)
- *2 When moving 25mm in vertical direction and 300mm in horizontal direction reciprocally.
- *3 There are limits to the setting of the acceleration coefficient.

Controller

Controller	Power consumption (VA)	Operating method
YRC	2500	Programming / I/O point trace / Remote command / Operation using RS-232C communication

Ordering information

Description	Model
SCARA Reach: 900mm, Vertical Stroke: 200mm, Max. payload: 20kg.	R6YXG900200YRC
SCARA Reach: 900mm, Vertical Stroke: 400mm, Max. payload: 20kg.	R6YXG900400YRC

Dimensions

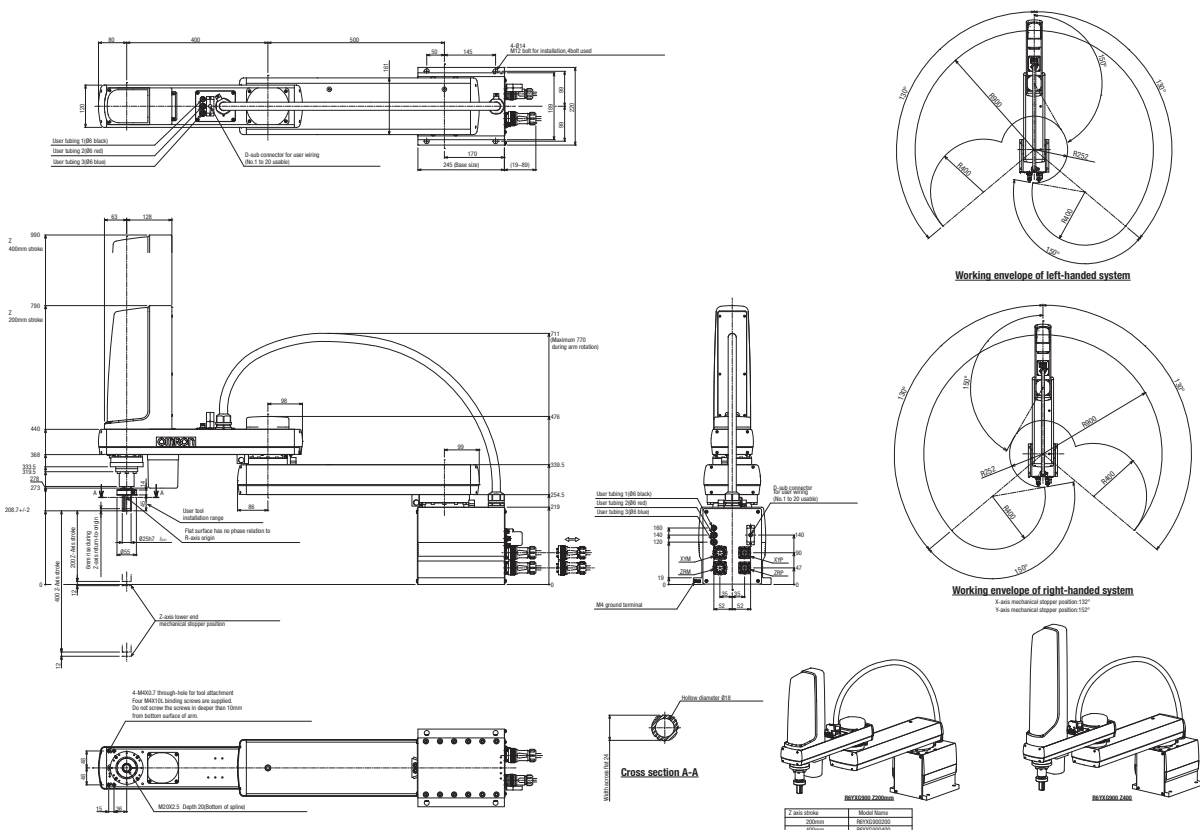

R6YXG1000 XG SERIES

Specifications

	X axis	Y axis	Z axis	R axis
Reach (mm)	1000			
Maximum payload (kg)	20			
Repeatability ^{*1} (XYZ:mm) (R:°)	+/-0.02		+/-0.01	+/-0.004
Axis specifications	Arm length (mm)	600	400	200
	Rotation range (°)	+/-130	+/-150	----
Deceleration mechanism	Speed reducer	Harmonic drive	Harmonic drive	Ball screw
	Transmission method	Motor to speed reducer	Direct-coupled	Direct-coupled
AC servo motor output (W)	750	400	400	200
Maximum speed (XYZ:m/sec) (R:°/sec)	10.6		2.3	1.7
Standard cycle time: with 2kg payload ^{*2} (sec)	0.49			
R axis allowable moment inertia ^{*3} (kgm ²)	1			
User wiring (sq x pcs)	0.2 x 20			
User tubing (Outer diameter)	Ø6 x 3			
Movement limit setting	1.Soft limit 2.Mechanical stopper (X, Y, Z axis)			
Robot cable length (m)	Standard: 3.5 Option: 5, 10			
Weight (kg) (Excluding robot cable)	Z axis 200mm: 56, Z axis 400mm: 58			

- *1 This is the value at a constant ambient temperature. (X,Y axes)
- *2 When moving 25mm in vertical direction and 300mm in horizontal direction reciprocally.
- *3 There are limits to the setting of the acceleration coefficient

Controller

Controller	Power consumption (VA)	Operating method
YRC	2500	Programming / I/O point trace / Remote command / Operation using RS-232C communication

Ordering information

Description	Model
SCARA Reach: 1000mm, Vertical Stroke: 200mm, Max. payload: 20kg.	R6YXG1000200YRC
SCARA Reach: 1000mm, Vertical Stroke: 400mm, Max. payload: 20kg.	R6YXG1000400YRC

Dimensions

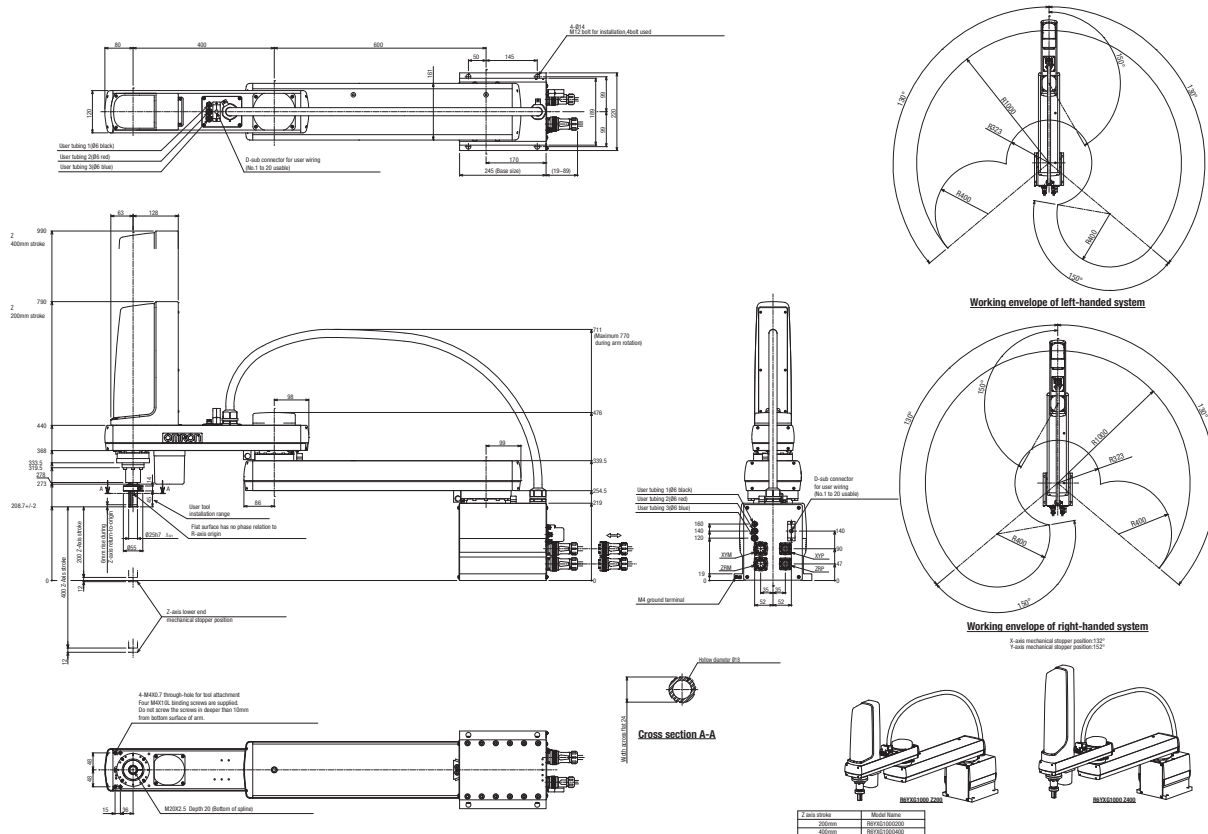

R6YXH250 X SERIES

Specifications

		X axis	Y axis	Z axis	R axis
Reach (mm)		250			
Maximum payload (kg)		3			
Repeatability ^{*1} (XYZ:mm) (R:°)		+/-0.01		+/-0.01	+/-0.005
Axis specifications	Arm length (mm)	125	125	150	----
	Rotation range (°)	+/-115	+/-140	----	+/-360
Deceleration mechanism	Speed reducer	Harmonic drive	Harmonic drive	Ball screw	Harmonic drive
	Transmission method	Motor to speed reducer	Direct-coupled		Timing belt transmission
		Speed reducer to output	Direct-coupled		
AC servo motor output (W)		200	100	100	100
Maximum speed (XYZ:m/sec) (R:°/sec)		4		1	1020
Standard cycle time: with 2kg payload ^{*2} (sec)		0.54			
R axis allowable moment inertia ^{*3} (kgm ²)		0.05			
User wiring (sq x pcs)		0.2 x 10			
User tubing (Outer diameter)		Ø4 x 3			
Movement limit setting		1.Soft limit 2.Mechanical stopper (X, Y, Z axis)			
Robot cable length (m)		Standard: 3.5 Option: 5, 10			
Weight (kg) (Excluding robot cable)		15			

- *1 This is the value at a constant ambient temperature. (X,Y axes)
- *2 When moving 25mm in vertical direction and 300mm in horizontal direction reciprocally.
- *3 There are limits to the setting of the acceleration coefficient.

Controller

Controller	Power consumption (VA)	Operating method
YRC	1000	Programming / I/O point trace / Remote command / Operation using RS-232C communication

Ordering information

Description	Model
SCARA Reach: 250mm, Vertical Stroke: 150mm, Max. payload: 3kg.	R6YXH250150YRC

Dimensions

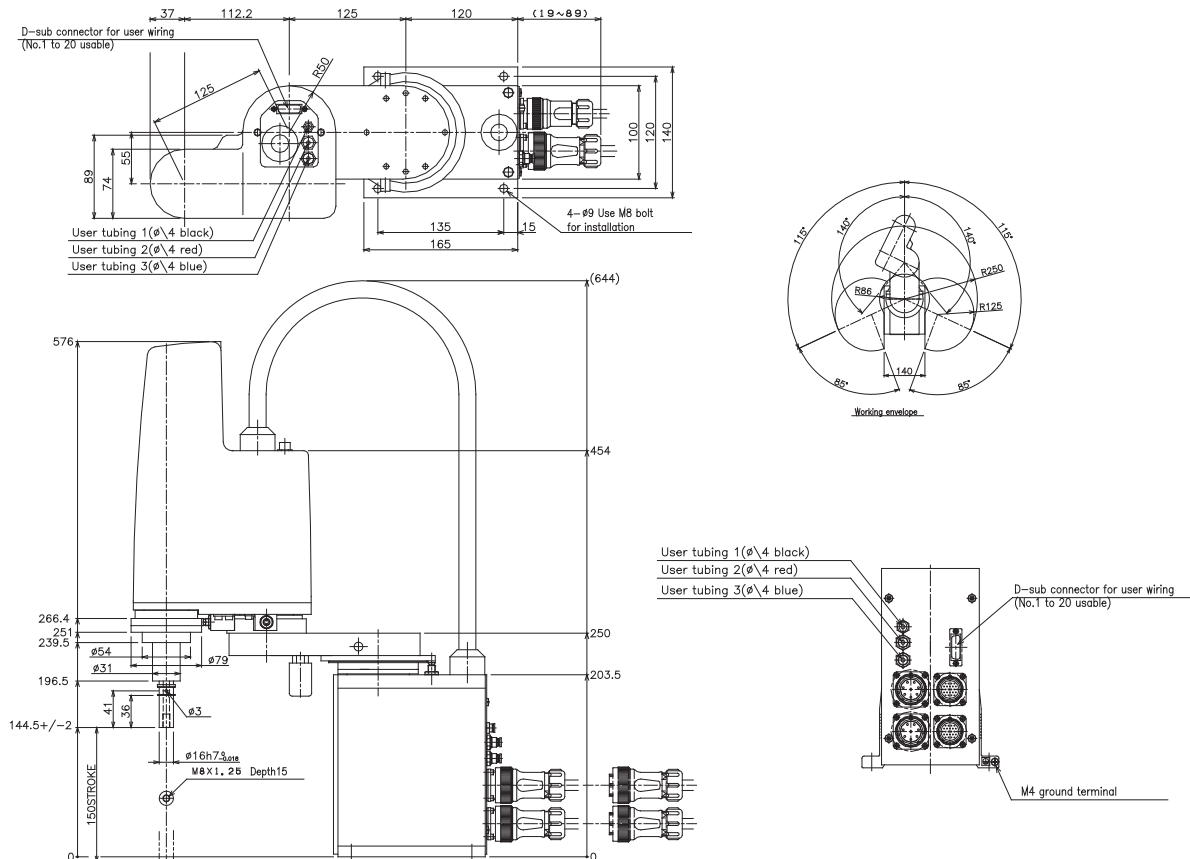

R6YXH350 X SERIES

Specifications

	X axis	Y axis	Z axis	R axis
Reach (mm)	350			
Maximum payload (kg)	3			
Repeatability ^{*1} (XYZ:mm) (R:°)	+/-0.01		+/-0.01	+/-0.005
Axis specifications	Arm length (mm)	125	150	----
	Rotation range (°)	+/-115	+/-140	----
Deceleration mechanism	Speed reducer	Harmonic drive	Harmonic drive	Ball screw
	Transmission method	Motor to speed reducer	Direct-coupled	Timing belt transmission
		Speed reducer to output	Direct-coupled	
AC servo motor output (W)	200	100	100	100
Maximum speed (XYZ:m/sec) (R:°/sec)	5		1	1020
Standard cycle time: with 2kg payload ^{*2} (sec)	0.54			
R axis allowable moment inertia ^{*3} (kgm ²)	0.05			
User wiring (sq x pcs)	0.2 x 10			
User tubing (Outer diameter)	Ø4 x 3			
Movement limit setting	1.Soft limit 2.Mechanical stopper (X, Y, Z axis)			
Robot cable length (m)	Standard: 3.5 Option: 5, 10			
Weight (kg) (Excluding robot cable)	15			

- *1 This is the value at a constant ambient temperature. (X,Y axes)
- *2 When moving 25mm in vertical direction and 300mm in horizontal direction reciprocally.
- *3 There are limits to the setting of the acceleration coefficient.

Controller

Controller	Power consumption (VA)	Operating method
YRC	1000	Programming / I/O point trace / Remote command / Operation using RS-232C communication

Ordering information

Description	Model
SCARA Reach: 350mm, Vertical Stroke: 150mm, Max. payload: 3kg.	R6YXH350150YRC

Dimensions

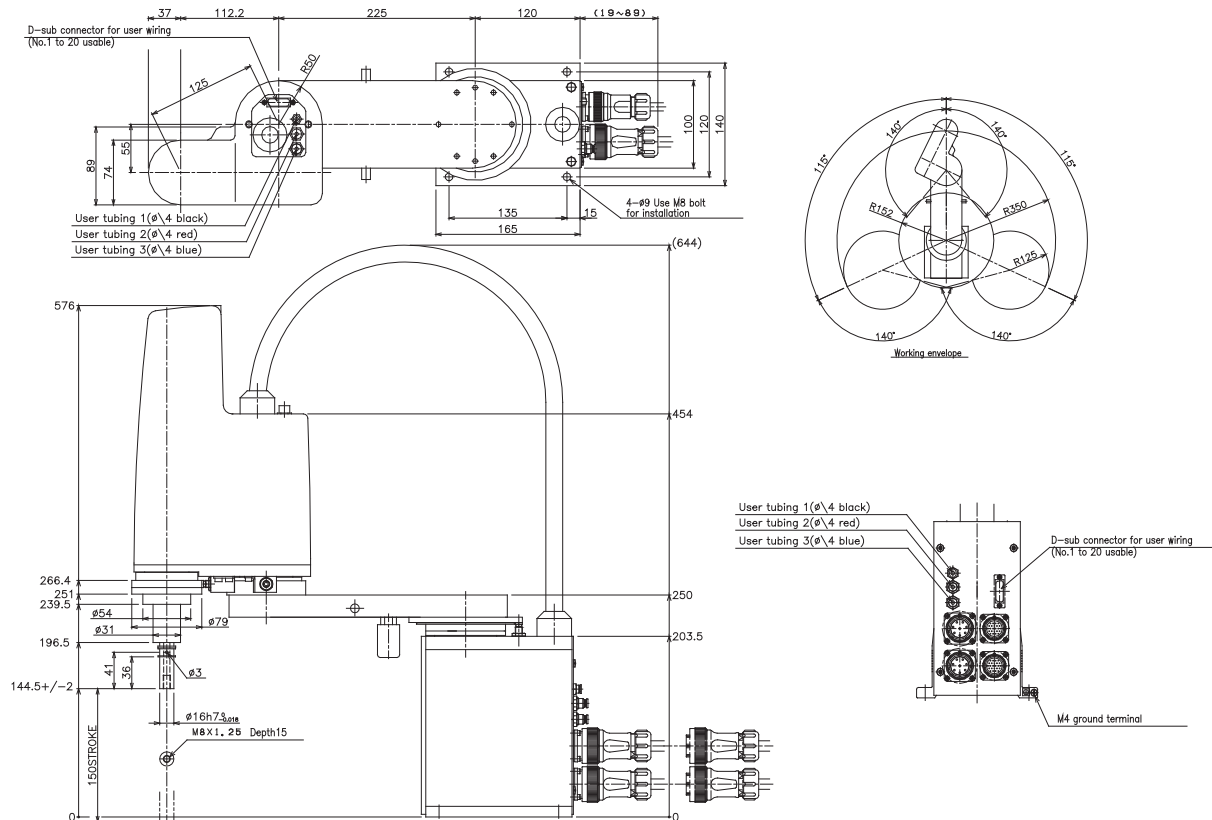

R6YXH400 X SERIES

Specifications

		X axis	Y axis	Z axis	R axis
Reach (mm)		400			
Maximum payload (kg)		3			
Repeatability ^{*1} (XYZ:mm) (R:°)		+/-0.01		+/-0.01	+/-0.005
Axis specifications	Arm length (mm)	225	175	150	----
	Rotation range (°)	+/-115	+/-140	----	+/-360
Deceleration mechanism	Speed reducer	Harmonic drive	Harmonic drive	Ball screw	Harmonic drive
	Transmission method	Motor to speed reducer	Direct-coupled		Timing belt transmission
		Speed reducer to output	Direct-coupled		
AC servo motor output (W)		200	100	100	100
Maximum speed (XYZ:m/sec) (R:°/sec)		6		1	1020
Standard cycle time: with 2kg payload ^{*2} (sec)		0.49			
R axis allowable moment inertia ^{*3} (kgm ²)		0.05			
User wiring (sq x pcs)		0.2 x 10			
User tubing (Outer diameter)		Ø4 x 3			
Movement limit setting		1.Soft limit 2.Mechanical stopper (X, Y, Z axis)			
Robot cable length (m)		Standard: 3.5 Option: 5, 10			
Weight (kg) (Excluding robot cable)		15			

- *1 This is the value at a constant ambient temperature. (X,Y axes)
- *2 When moving 25mm in vertical direction and 300mm in horizontal direction reciprocally.
- *3 There are limits to the setting of the acceleration coefficient.

Controller

Controller	Power consumption (VA)	Operating method
YRC	1000	Programming / I/O point trace / Remote command / Operation using RS-232C communication

Ordering information

Description	Model
SCARA Reach: 400mm, Vertical Stroke: 150mm, Max. payload: 3kg.	R6YXH400150YRC

Dimensions

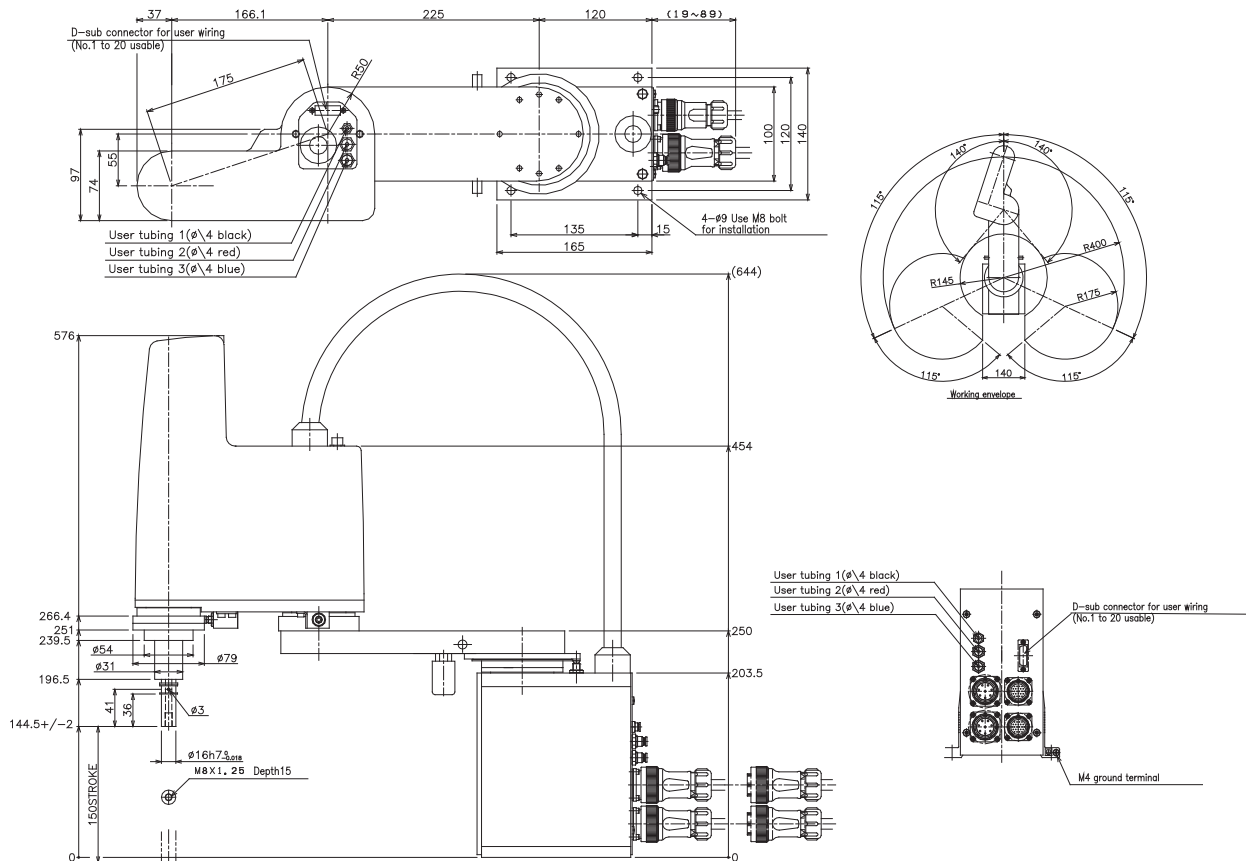

R6YXX1200 X SERIES

Specifications

	X axis	Y axis	Z axis	R axis
Reach (mm)	1200			
Maximum payload (kg)	50			
Repeatability ^{*1} (XYZ:mm) (R:°)	+/-0.05		+/-0.02	+/-0.005
Axis specifications	Arm length (mm)	600	400	----
	Rotation range (°)	+/-125	+/-150	----
Deceleration mechanism	Speed reducer	Planetary gear	Planetary gear	Ball screw
	Transmission method	Motor to speed reducer	Direct-coupled	Timing belt transmission
		Speed reducer to output	Direct-coupled	Timing belt transmission
AC servo motor output (W)	900	800	600	400
Maximum speed (XYZ:m/sec) (R:°/sec)	7.4		0.75	600
Standard cycle time: with 2kg payload ^{*2} (sec)	0.91			
R axis allowable moment inertia ^{*3} (kgm ²)	2.45			
User wiring (sq x pcs)	0.2 x 20			
User tubing (Outer diameter)	Ø6 x 3			
Movement limit setting	1.Soft limit 2.Mechanical stopper (X, Y, Z axis)			
Robot cable length (m)	Standard: 3.5 Option: 5, 10			
Weight (kg) (Excluding robot cable)	124			

*1 This is the value at a constant ambient temperature. (X,Y axes)
 *2 When moving 25mm in vertical direction and 300mm in horizontal direction reciprocally.
 *3 There are limits to the setting of the acceleration coefficient.

Controller

Controller	Power consumption (VA)	Operating method
YRC	2500	Programming / I/O point trace / Remote command / Operation using RS-232C communication

Ordering information

Description	Model
SCARA Reach: 1200mm, Vertical Stroke: 400mm, Max. payload: 50kg.	R6YXX1200400YRC

Dimensions

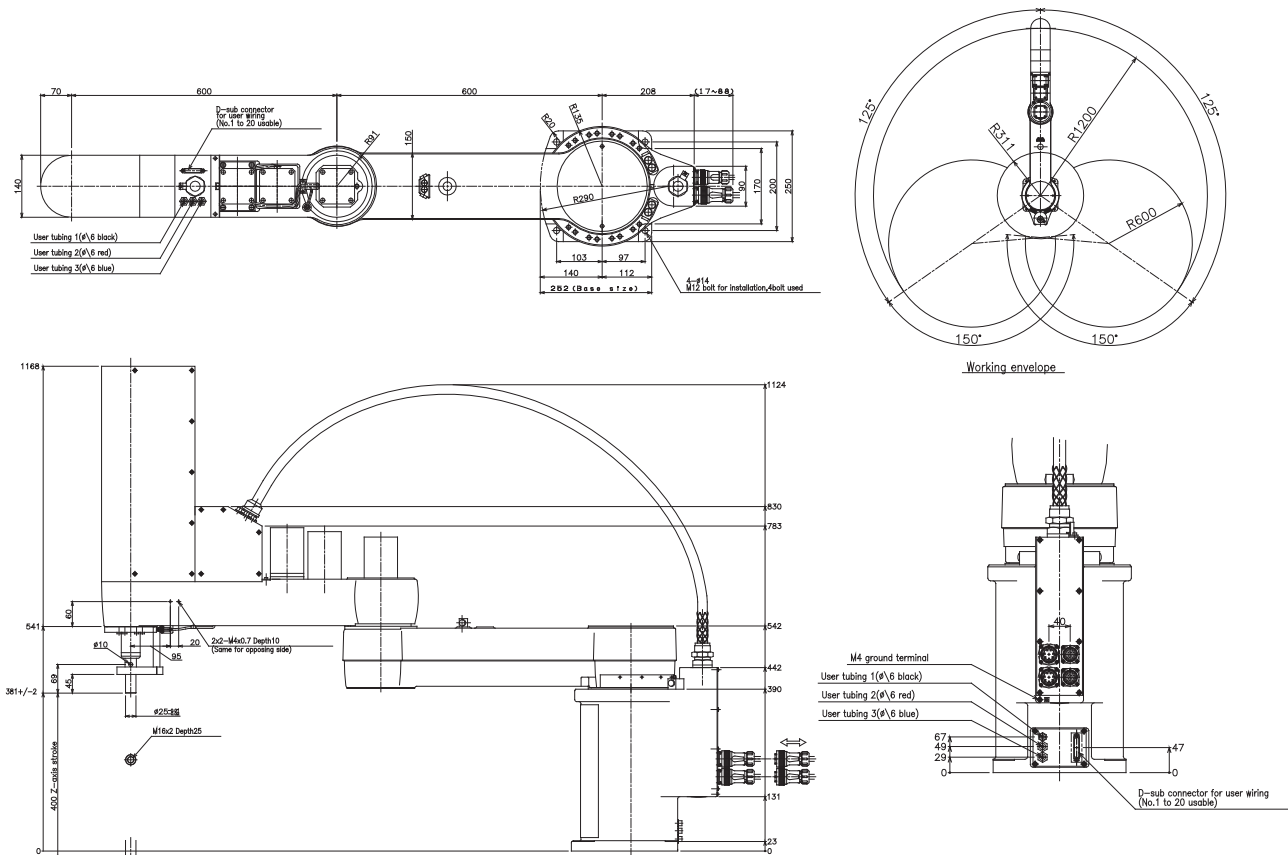

R6YXC220 CLEAN TYPE

Specifications

	X axis	Y axis	Z axis	R axis
Reach (mm)	220			
Maximum payload (kg)	1			
Repeatability ^{*1} (XYZ:mm) (R:°)	+/-0.01		+/-0.01	+/-0.004
Axis specifications	Arm length (mm)	109	100	----
	Rotation range (°)	+/-120	+/-140	----
AC servo motor output (W)	50	30	30	30
Maximum speed (XYZ:m/sec) (R:°/sec)	3.4		0.7	1700
Standard cycle time: with 0.1kg payload ^{*2} (sec)	0.45			
R axis allowable moment inertia ^{*3} (kgm ²)	0.01			
User wiring (sq x pcs)	0.1 x 8			
User tubing (Outer diameter)	Ø3 x 2			
Movement limit setting	1.Soft limit 2.Mechanical stopper (X, Y, Z axis)			
Robot cable length (m)	Standard: 3.5 Option: 5, 10			
Weight (kg) (Excluding robot cable) ^{*4}	6.5			
Robot cable weight	1.5kg (3.5m), 2.1kg (5m), 4.2kg (10m)			
Degree of cleanliness	CLASS 10 (0.1 micron base)			
Intake air (N l/min)	30			

- *1 This is the value at a constant ambient temperature. (X,Y axes)
- *2 When moving 25mm in vertical direction and 100mm in horizontal direction reciprocally.
- *3 There are limits to the setting of the acceleration coefficient.
- *4 The total robot weight is the sum of the robot body weight and the cable weight.

Controller

Controller	Power consumption (VA)	Operating method
YRC	500	Programming / I/O point trace / Remote command / Operation using RS-232C communication

Ordering information

Description	Model
SCARA Reach: 220mm, Vertical Stroke: 100mm, Max. payload: 1kg, Protection class: C10	R6YXC220100YRC

Dimensions

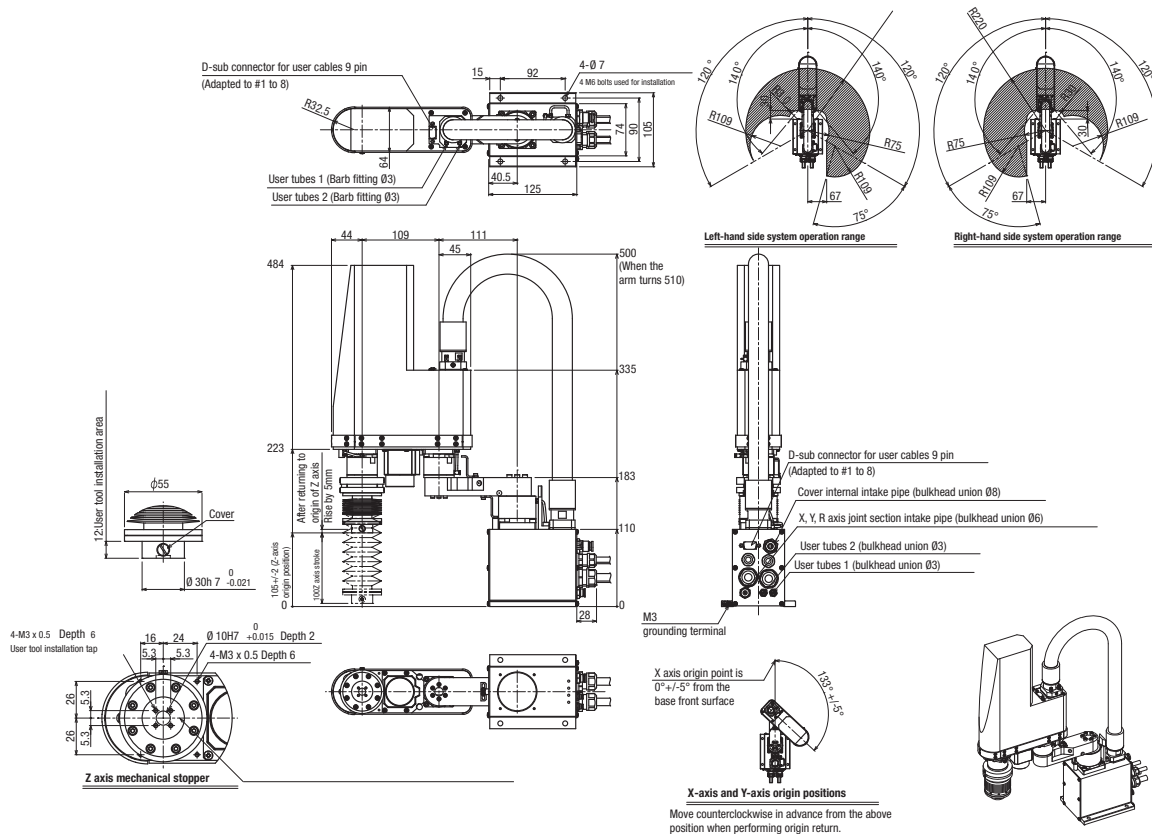

R6YXCH250 CLEAN TYPE

Specifications

	X axis	Y axis	Z axis	R axis
Reach (mm)	250			
Maximum payload (kg)	3			
Repeatability ^{*1} (XYZ:mm) (R:°)	+/-0.01		+/-0.01	+/-0.005
Axis specifications	Arm length (mm)	125	150	----
	Rotation range (°)	+/-115	+/-130	----
AC servo motor output (W)	200	100	100	100
Maximum speed (XYZ:m/sec) (R:°/sec)	4		1	1020
Standard cycle time: with 2kg payload ^{*2} (sec)	0.54			
R axis allowable moment inertia ^{*3} (kgm ²)	0.05			
User wiring (sq x pcs)	0.2 x 10			
User tubing (Outer diameter)	Ø4 x 3			
Movement limit setting	1.Soft limit 2.Mechanical stopper (X, Y, Z axis)			
Robot cable length (m)	Standard: 3.5 Option: 5, 10			
Weight (kg)	16			
Degree of cleanliness	CLASS 10 ⁻⁴			
Intake air (N l/min)	60 ^{*5}			

- *1 This is the value at a constant ambient temperature. (X, Y axes)
- *2 When moving 25mm in vertical direction and 300mm in horizontal direction reciprocally.
- *3 There are limits to the setting of the acceleration coefficient.
- *4 Per 1 cf (0.1micron base), when suction blower is used.
- *5 The necessary intake amount varies depending on the use conditions and environment.

Controller

Controller	Power consumption (VA)	Operating method
YRC	1000	Programming / I/O point trace / Remote command / Operation using RS-232C communication

Ordering information

Description	Model
SCARA Reach: 250mm, Vertical Stroke: 150mm, Max. payload: 3kg, Protection class: C10	R6YXCH250150YRC

Dimensions

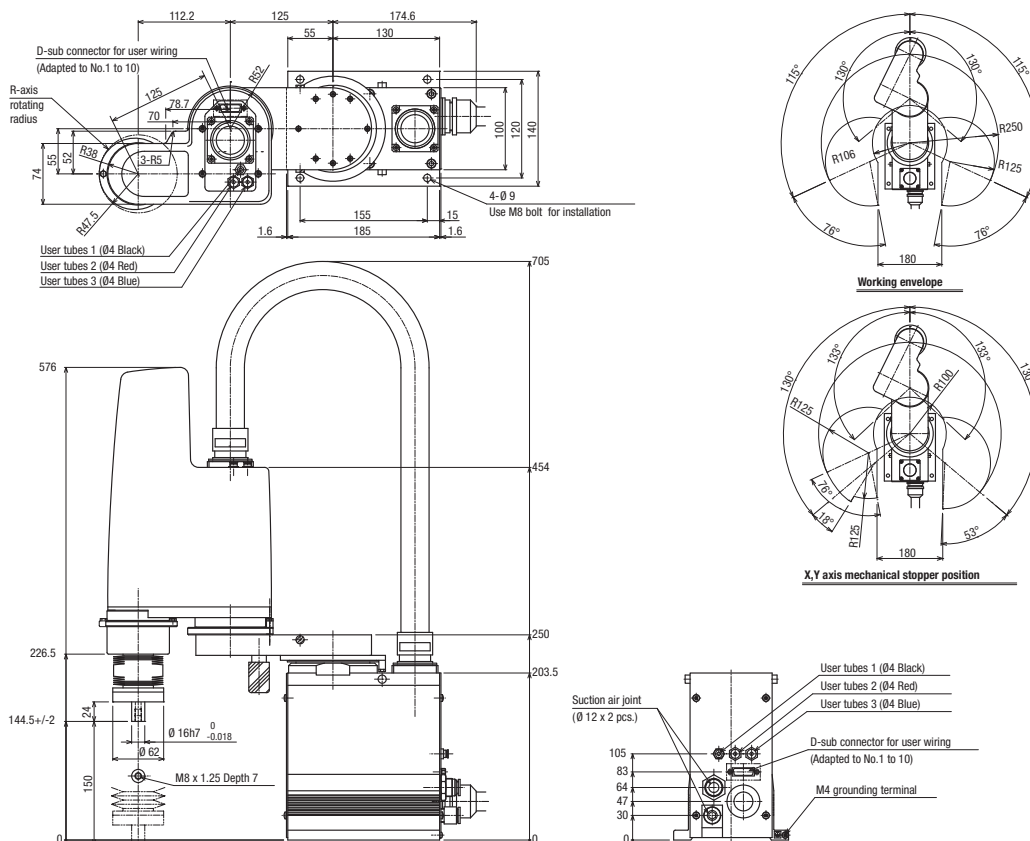

R6YXCH400 CLEAN TYPE

Specifications

	X axis	Y axis	Z axis	R axis
Reach (mm)	400			
Maximum payload (kg)	3			
Repeatability ^{*1} (XYZ:mm) (R:°)	+/-0.01		+/-0.01	+/-0.005
Axis specifications	Arm length (mm)	175	150	----
	Rotation range (°)	+/-115	+/-143	----
AC servo motor output (W)	200	100	100	100
Maximum speed (XYZ:m/sec) (R:°/sec)	6		1	1020
Standard cycle time: with 2kg payload ^{*2} (sec)	0.66			
R axis allowable moment inertia ^{*3} (kgm ²)	0.05			
User wiring (sq x pcs)	0.2 x 10			
User tubing (Outer diameter)	Ø4 x 3			
Movement limit setting	1.Soft limit 2.Mechanical stopper (X, Y, Z axis)			
Robot cable length (m)	Standard: 3.5 Option: 5, 10			
Weight (kg)	16			
Degree of cleanliness	CLASS 10 ⁻⁴			
Intake air (N l/min)	60 ^{*5}			

- *1 This is the value at a constant ambient temperature. (X,Y axes)
- *2 When moving 25mm in vertical direction and 300mm in horizontal direction reciprocally.
- *3 There are limits to the setting of the acceleration coefficient.
- *4 Per 1 cf (0.1micron base), when suction blower is used.
- *5 The necessary intake amount varies depending on the use conditions and environment.

Controller

Controller	Power consumption (VA)	Operating method
YRC	1000	Programming / I/O point trace / Remote command / Operation using RS-232C communication

Ordering information

Description	Model
SCARA Reach: 400mm, Vertical Stroke: 150mm, Max. payload: 3kg, Protection class: C10	R6YXCH400150YRC

Dimensions

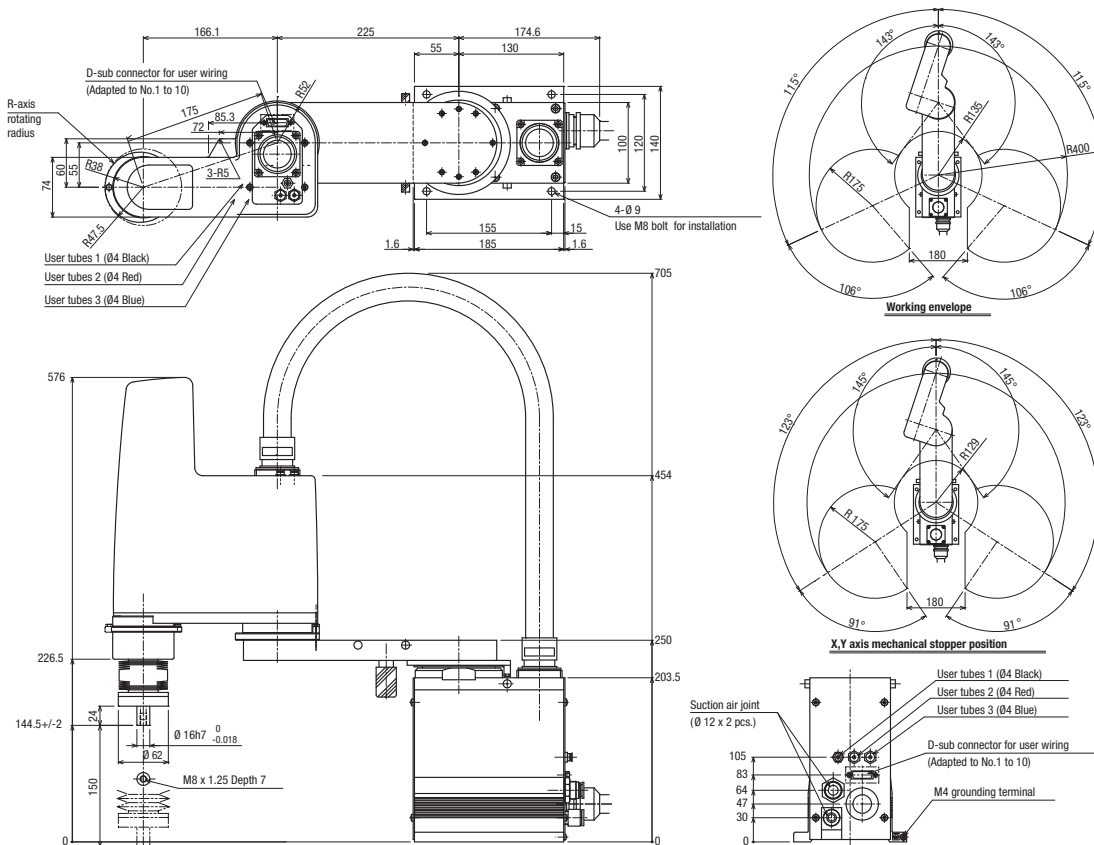

R6YXC500 CLEAN TYPE

Specifications

	X axis	Y axis	Z axis	R axis
Reach (mm)	500			
Maximum payload (kg)	10			
Repeatability ¹ (XYZ:mm) (R:°)	+/-0.02		+/-0.01	+/-0.005
Axis specifications	Arm length (mm)	250	200	300
	Rotation range (°)	+/-120	+/-142	----
AC servo motor output (W)	400	200	200	100
Maximum speed (XYZ:m/sec) (R:°/sec)	4.9		1.7	876
Standard cycle time: with 2kg payload ² (sec)	0.53			
R axis allowable moment inertia ³ (kgm ²)	0.12			
User wiring (sq x pcs)	0.2 x 20			
User tubing (Outer diameter)	Ø6 x 3			
Movement limit setting	1.Soft limit 2.Mechanical stopper (X, Y, Z axis)			
Robot cable length (m)	Standard: 3.5 Option: 5, 10			
Weight (kg)	31			
Degree of cleanliness	CLASS 10 ⁴			
Intake air (N l/min)	60 ⁵			

- *1 This is the value at a constant ambient temperature. (X,Y axes)
- *2 When moving 25mm in vertical direction and 300mm in horizontal direction reciprocally.
- *3 There are limits to the setting of the acceleration coefficient.
- *4 Per 1 cf (0.1micron base), when suction blower is used.
- *5 The necessary intake amount varies depending on the use conditions and environment.

Controller

Controller	Power consumption (VA)	Operating method
YRC	1500	Programming / I/O point trace / Remote command / Operation using RS-232C communication

Ordering information

Description	Model
SCARA Reach: 500mm, Vertical Stroke: 200mm, Max. payload: 10kg, Protection class: C10	R6YXC500200YRC
SCARA Reach: 500mm, Vertical Stroke: 300mm, Max. payload: 10kg, Protection class: C10	R6YXC500300YRC

Dimensions

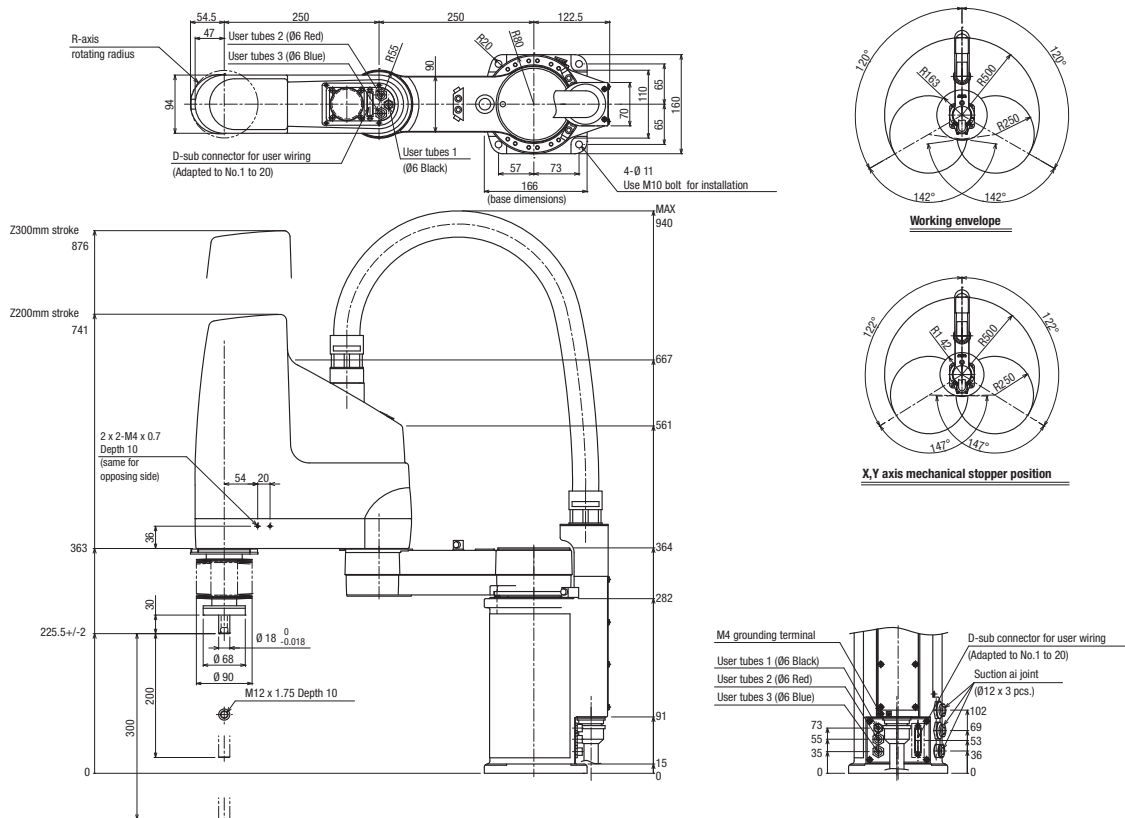

R6YXC600 CLEAN TYPE

Specifications

	X axis	Y axis	Z axis	R axis
Reach (mm)	600			
Maximum payload (kg)	10			
Repeatability ^{*1} (XYZ:mm) (R:°)	+/-0.02		+/-0.01	+/-0.005
Axis specifications	Arm length (mm)	250	200	300
	Rotation range (°)	+/-120	+/-145	----
AC servo motor output (W)	400	200	200	100
Maximum speed (XYZ:m/sec) (R:°/sec)	5.6		1.7	876
Standard cycle time: with 2kg payload ^{*2} (sec)	0.56			
R axis allowable moment inertia ^{*3} (kgm ²)	0.12			
User wiring (sq x pcs)	0.2 x 20			
User tubing (Outer diameter)	Ø6 x 3			
Movement limit setting	1.Soft limit 2.Mechanical stopper (X, Y, Z axis)			
Robot cable length (m)	Standard: 3.5 Option: 5, 10			
Weight (kg)	33			
Degree of cleanliness	CLASS 10 ^{*4}			
Intake air (N l/min)	60 ^{*5}			

- *1 This is the value at a constant ambient temperature. (X,Y axes)
- *2 When moving 25mm in vertical direction and 300mm in horizontal direction reciprocally.
- *3 There are limits to the setting of the acceleration coefficient.
- *4 Per 1 cf (0.1micron base), when suction blower is used.
- *5 The necessary intake amount varies depending on the use conditions and environment.

Controller

Controller	Power consumption (VA)	Operating method
YRC	1500	Programming / I/O point trace / Remote command / Operation using RS-232C communication

Ordering information

Description	Model
SCARA Reach: 600mm, Vertical Stroke: 200mm, Max. payload: 10kg, Protection class: C10	R6YXC600200YRC
SCARA Reach: 600mm, Vertical Stroke: 300mm, Max. payload: 10kg, Protection class: C10	R6YXC600300YRC

Dimensions

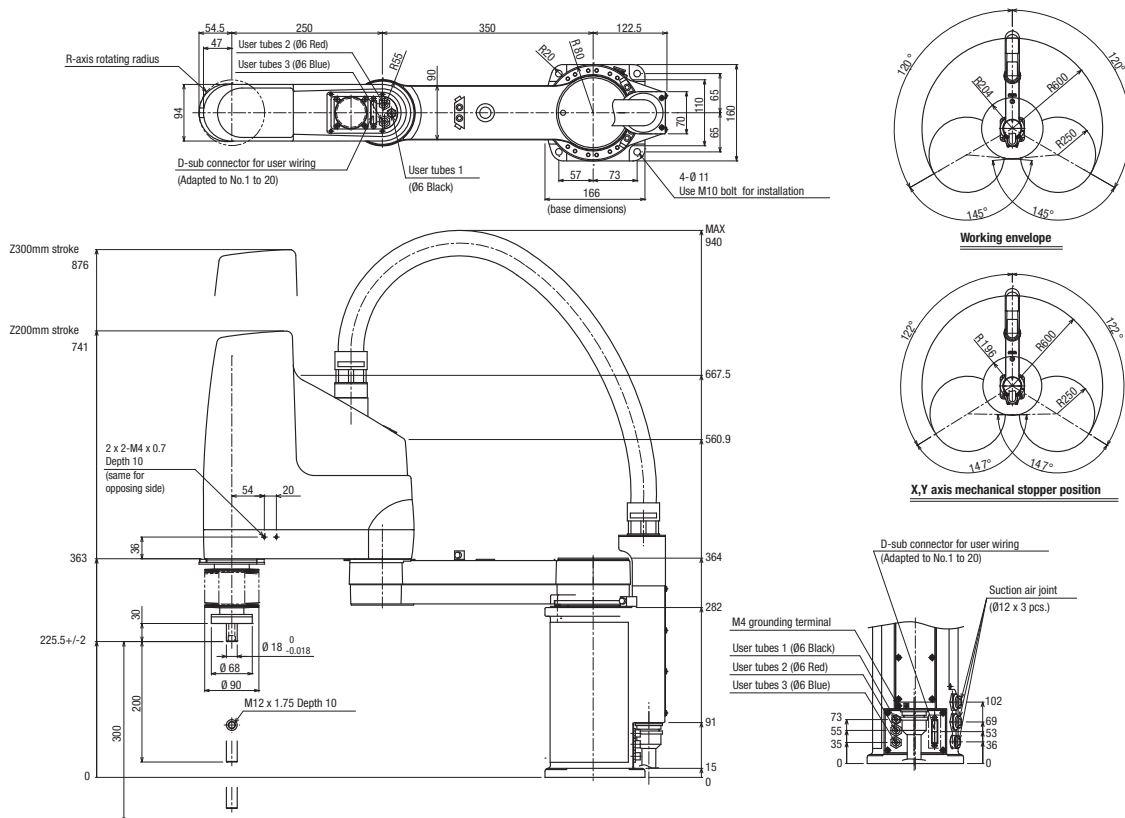

R6YXC700 CLEAN TYPE

Specifications

	X axis	Y axis	Z axis	R axis
Reach (mm)	700			
Maximum payload (kg)	20			
Repeatability ¹ (XYZ:mm) (R:°)	+/-0.02		+/-0.01	+/-0.005
Axis specifications	Arm length (mm)	350	200	400
	Rotation range (°)	+/-120	+/-145	----
AC servo motor output (W)	800	400	400	200
Maximum speed (XYZ:m/sec) (R:°/sec)	6.7		1.7	600
Standard cycle time: with 2kg payload ² (sec)	0.57			
R axis allowable moment inertia ³ (kgm ²)	0.32			
User wiring (sq x pcs)	0.2 x 20			
User tubing (Outer diameter)	Ø6 x 3			
Movement limit setting	1.Soft limit 2.Mechanical stopper (X, Y, Z axis)			
Robot cable length (m)	Standard: 3.5 Option: 5, 10			
Weight (kg)	57			
Degree of cleanliness	CLASS 10 ⁻⁴			
Intake air (N l/min)	60 ⁵			

- *1 This is the value at a constant ambient temperature. (X,Y axes)
- *2 When moving 25mm in vertical direction and 300mm in horizontal direction reciprocally.
- *3 There are limits to the setting of the acceleration coefficient.
- *4 Per 1 cf (0.1micron base), when suction blower is used.
- *5 The necessary intake amount varies depending on the use conditions and environment.

Controller

Controller	Power consumption (VA)	Operating method
YRC	2000	Programming / I/O point trace / Remote command / Operation using RS-232C communication

Ordering information

Description	Model
SCARA Reach: 700mm, Vertical Stroke: 200mm, Max. payload: 20kg, Protection class: C10	R6YXC700200YRC
SCARA Reach: 700mm, Vertical Stroke: 400mm, Max. payload: 20kg, Protection class: C10	R6YXC700400YRC

Dimensions

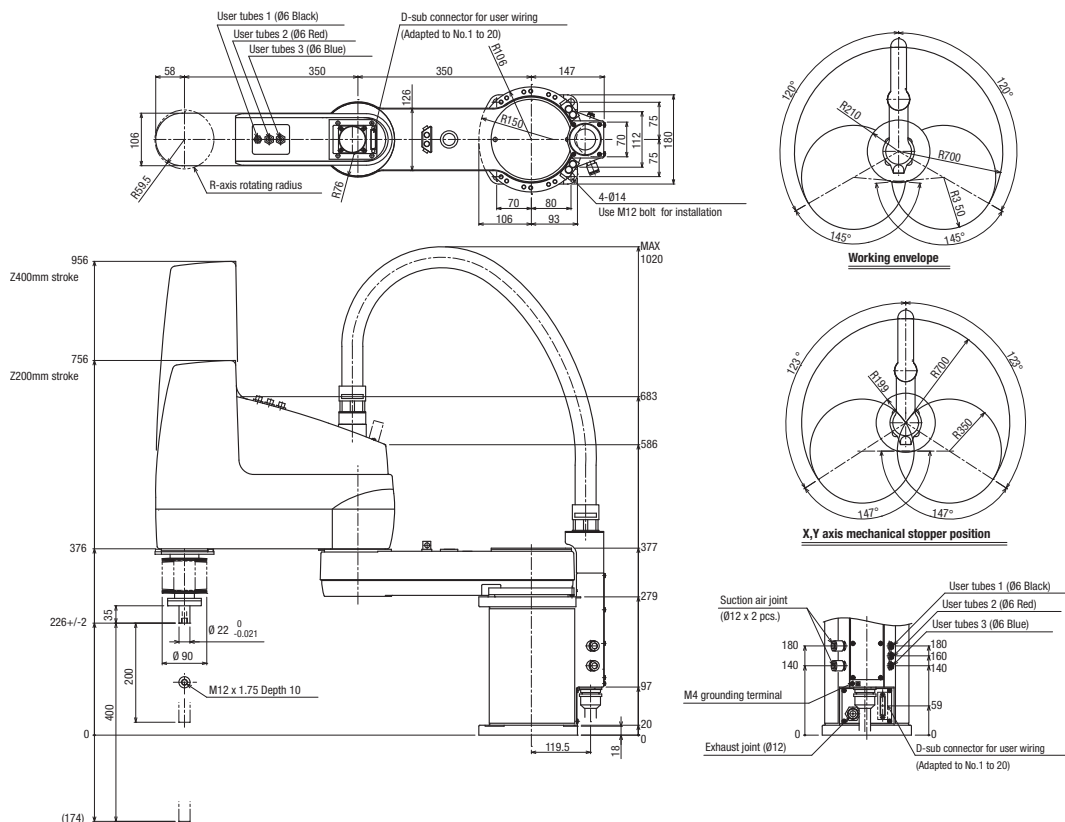

R6YXC800 CLEAN TYPE

Specifications

	X axis	Y axis	Z axis	R axis
Reach (mm)	800			
Maximum payload (kg)	20			
Repeatability ^{*1} (XYZ:mm) (R:°)	+/-0.02		+/-0.01	+/-0.005
Axis specifications	Arm length (mm)	350	200	400
	Rotation range (°)	+/-120	+/-145	----
AC servo motor output (W)	800	400	400	200
Maximum speed (XYZ:m/sec) (R:°/sec)	7.3		1.7	600
Standard cycle time: with 2kg payload ^{*2} (sec)	0.57			
R axis allowable moment inertia ^{*3} (kgm ²)	0.32			
User wiring (sq x pcs)	0.2 x 20			
User tubing (Outer diameter)	Ø6 x 3			
Movement limit setting	1.Soft limit 2.Mechanical stopper (X, Y, Z axis)			
Robot cable length (m)	Standard: 3.5 Option: 5, 10			
Weight (kg)	58			
Degree of cleanliness	CLASS 10 ⁻⁴			
Intake air (N l/min)	60 ^{*5}			

- *1 This is the value at a constant ambient temperature. (X,Y axes)
- *2 When moving 25mm in vertical direction and 300mm in horizontal direction reciprocally.
- *3 There are limits to the setting of the acceleration coefficient.
- *4 Per 1 cf (0.1micron base), when suction blower is used.
- *5 The necessary intake amount varies depending on the use conditions and environment.

Controller

Controller	Power consumption (VA)	Operating method
YRC	2000	Programming / I/O point trace / Remote command / Operation using RS-232C communication

Ordering information

Description	Model
SCARA Reach: 800mm, Vertical Stroke: 200mm, Max. payload: 20kg, Protection class: C10	R6YXC800200YRC
SCARA Reach: 800mm, Vertical Stroke: 400mm, Max. payload: 20kg, Protection class: C10	R6YXC800400YRC

Dimensions

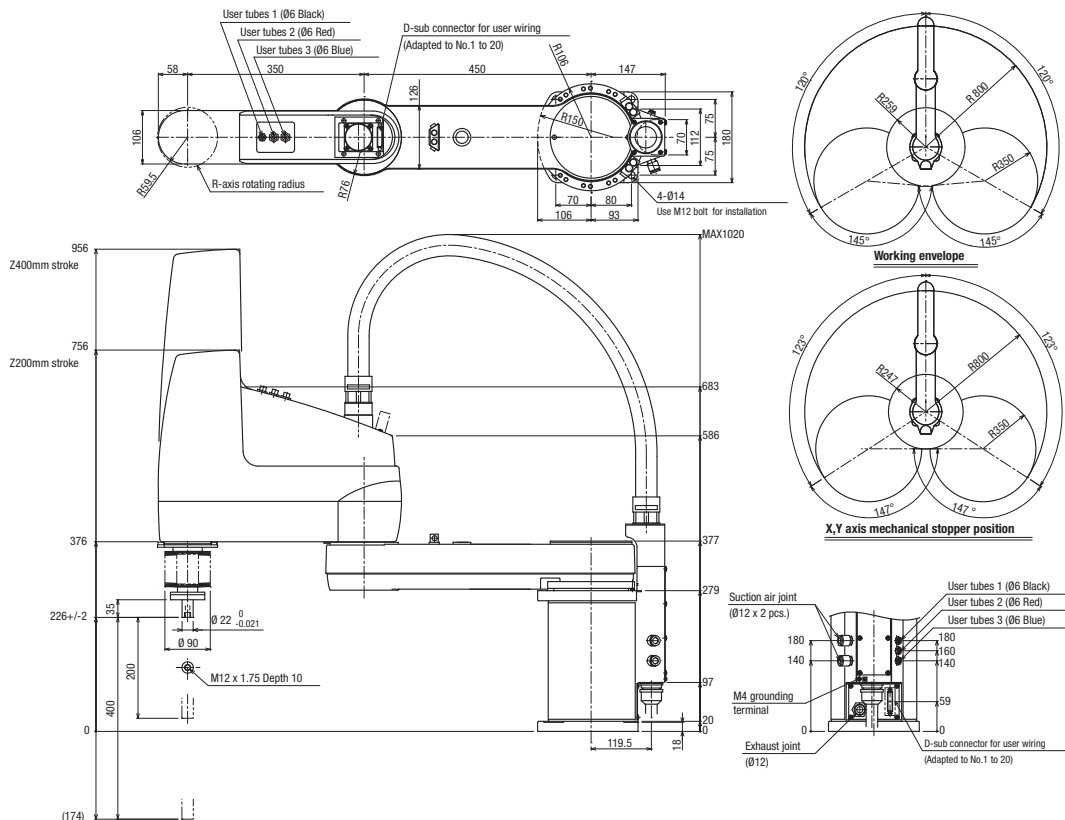

R6YXC1000 CLEAN TYPE

Specifications

	X axis	Y axis	Z axis	R axis
Reach (mm)	1000			
Maximum payload (kg)	20			
Repeatability ¹ (XYZ:mm) (R:°)	+/-0.02		+/-0.01	+/-0.005
Axis specifications	Arm length (mm)	450	200	400
	Rotation range (°)	+/-120	+/-145	----
AC servo motor output (W)	800	400	400	200
Maximum speed (XYZ:m/sec) (R:°/sec)	8		1.7	600
Standard cycle time: with 2kg payload ² (sec)	0.6			
R axis allowable moment inertia ³ (kgm ²)	0.32			
User wiring (sq x pcs)	0.2 x 20			
User tubing (Outer diameter)	Ø6 x 3			
Movement limit setting	1.Soft limit 2.Mechanical stopper (X, Y, Z axis)			
Robot cable length (m)	Standard: 3.5 Option: 5, 10			
Weight (kg)	59			
Degree of cleanliness	CLASS 10 ⁻⁴			
Intake air (N l/min)	60 ⁵			

- *1 This is the value at a constant ambient temperature. (X,Y axes)
- *2 When moving 25mm in vertical direction and 300mm in horizontal direction reciprocally.
- *3 There are limits to the setting of the acceleration coefficient.
- *4 Per 1 cf (0.1micron base), when suction blower is used.
- *5 The necessary intake amount varies depending on the use conditions and environment.

Controller

Controller	Power consumption (VA)	Operating method
YRC	2000	Programming / I/O point trace / Remote command / Operation using RS-232C communication

Ordering information

Description	Model
SCARA Reach: 1000mm, Vertical Stroke: 200mm, Max. payload: 20kg, Protection class: C10	R6YXC1000200YRC
SCARA Reach: 1000mm, Vertical Stroke: 400mm, Max. payload: 20kg, Protection class: C10	R6YXC1000400YRC

Dimensions

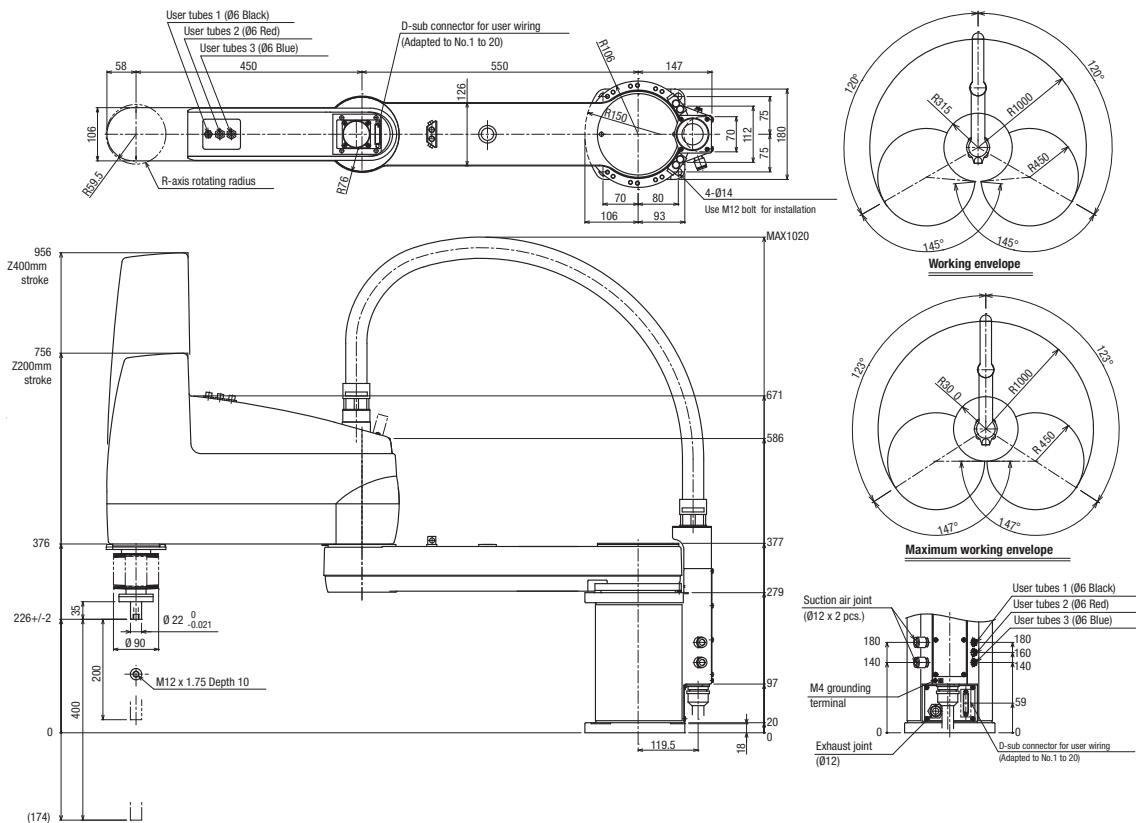

R6YXP250 DUST-PROOF & DRIP-PROOF TYPE

Specifications

		X axis	Y axis	Z axis	R axis
Reach (mm)		250			
Maximum payload (kg)		3			
Repeatability ^{*1} (XYZ:mm) (R:°)		+/-0.01		+/-0.01	+/-0.005
Axis specifications	Arm length (mm)	125	125	150	----
	Rotation range (°)	+/-115	+/-130	----	+/-360
Deceleration mechanism	Speed reducer	Harmonic drive	Harmonic drive	Ball screw	Harmonic drive
	Transmission method	Motor to speed reducer	Direct-coupled		Timing belt transmission
		Speed reducer to output	Direct-coupled		
AC servo motor output (W)		200	100	100	100
Maximum speed (XYZ:m/sec) (R:°/sec)		4		1	1020
Standard cycle time: with 2kg payload ^{*2} (sec)		0.54			
R axis allowable moment inertia ^{*3} (kgm ²)		0.05			
User wiring (sq x pcs)		0.2 x 10			
User tubing (Outer diameter)		Ø4 x 3			
Movement limit setting		1.Soft limit 2.Mechanical stopper (X, Y, Z axis)			
Robot cable length (m)		Standard: 3.5 Option: 5, 10			
Weight (kg) (Excluding robot cable)		15			

- *1 This is the value at a constant ambient temperature. (X,Y axes)
- *2 When moving 25mm in vertical direction and 300mm in horizontal direction reciprocally.
- *3 There are limits to the setting of the acceleration coefficient.

Controller

Controller	Power consumption (VA)	Operating method
YRC	1000	Programming / I/O point trace / Remote command / Operation using RS-232C communication

Ordering information

Description	Model
SCARA Reach: 250mm, Vertical Stroke: 150mm, Max. payload: 3kg, Protection class: IP65	R6YXP250150YRC

Dimensions

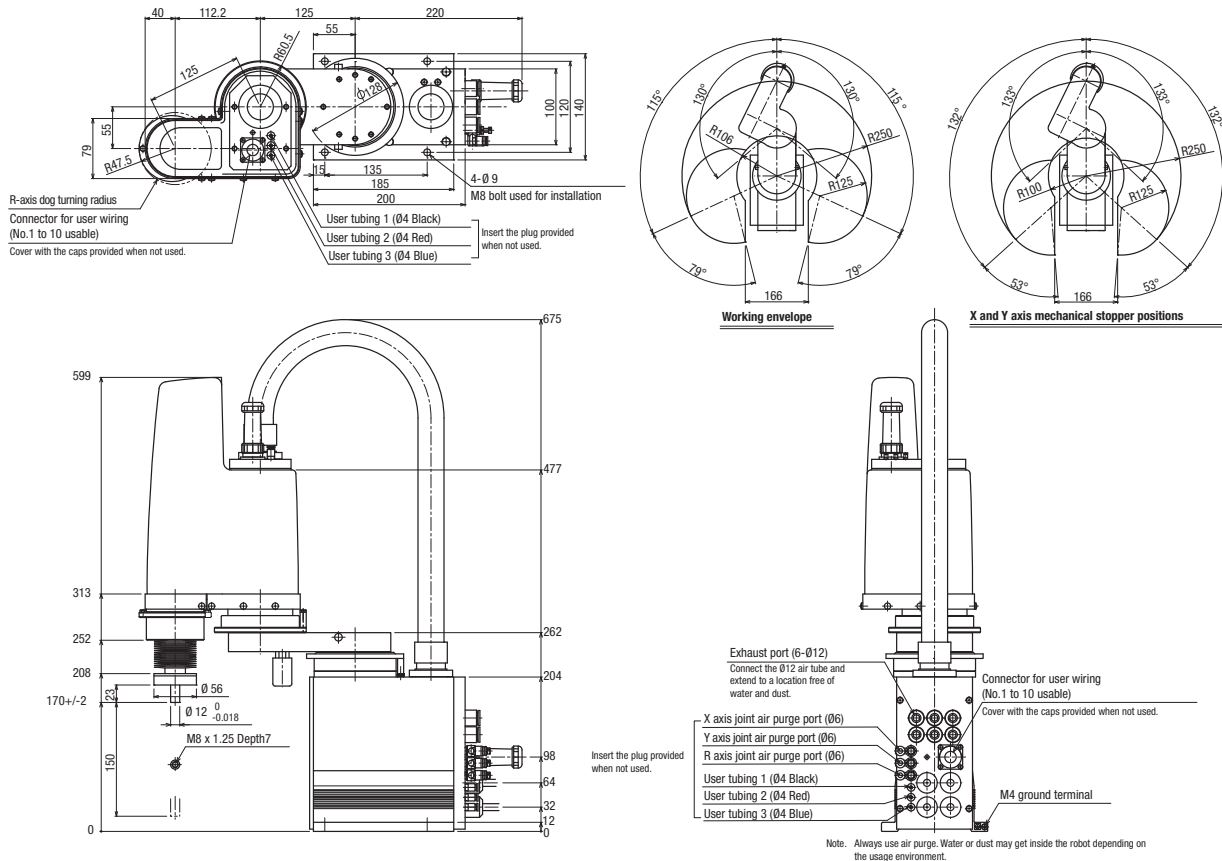

R6YXP350 DUST-PROOF & DRIP-PROOF TYPE

Specifications

	X axis	Y axis	Z axis	R axis
Reach (mm)	350			
Maximum payload (kg)	3			
Repeatability ^{*1} (XYZ:mm) (R:°)	+/-0.01		+/-0.01	+/-0.005
Axis specifications	Arm length (mm)	125	150	----
	Rotation range (°)	+/-115	+/-130	----
Deceleration mechanism	Speed reducer	Harmonic drive	Harmonic drive	Ball screw
	Transmission method	Motor to speed reducer	Direct-coupled	Timing belt transmission
		Speed reducer to output	Direct-coupled	
AC servo motor output (W)	200	100	100	100
Maximum speed (XYZ:m/sec) (R:°/sec)	5		1	1020
Standard cycle time: with 2kg payload ^{*2} (sec)	0.54			
R axis allowable moment inertia ^{*3} (kgm ²)	0.05			
User wiring (sq x pcs)	0.2 x 10			
User tubing (Outer diameter)	Ø4 x 3			
Movement limit setting	1.Soft limit 2.Mechanical stopper (X, Y, Z axis)			
Robot cable length (m)	Standard: 3.5 Option: 5, 10			
Weight (kg) (Excluding robot cable)	15			

*1 This is the value at a constant ambient temperature. (X,Y axes)
 *2 When moving 25mm in vertical direction and 300mm in horizontal direction reciprocally.
 *3 There are limits to the setting of the acceleration coefficient.

Controller

Controller	Power consumption (VA)	Operating method
YRC	1000	Programming / I/O point trace / Remote command / Operation using RS-232C communication

Ordering information

Description	Model
SCARA Reach: 350mm, Vertical Stroke: 150mm, Max. payload: 3kg, Protection class: IP65	R6YXP350150YRC

Dimensions

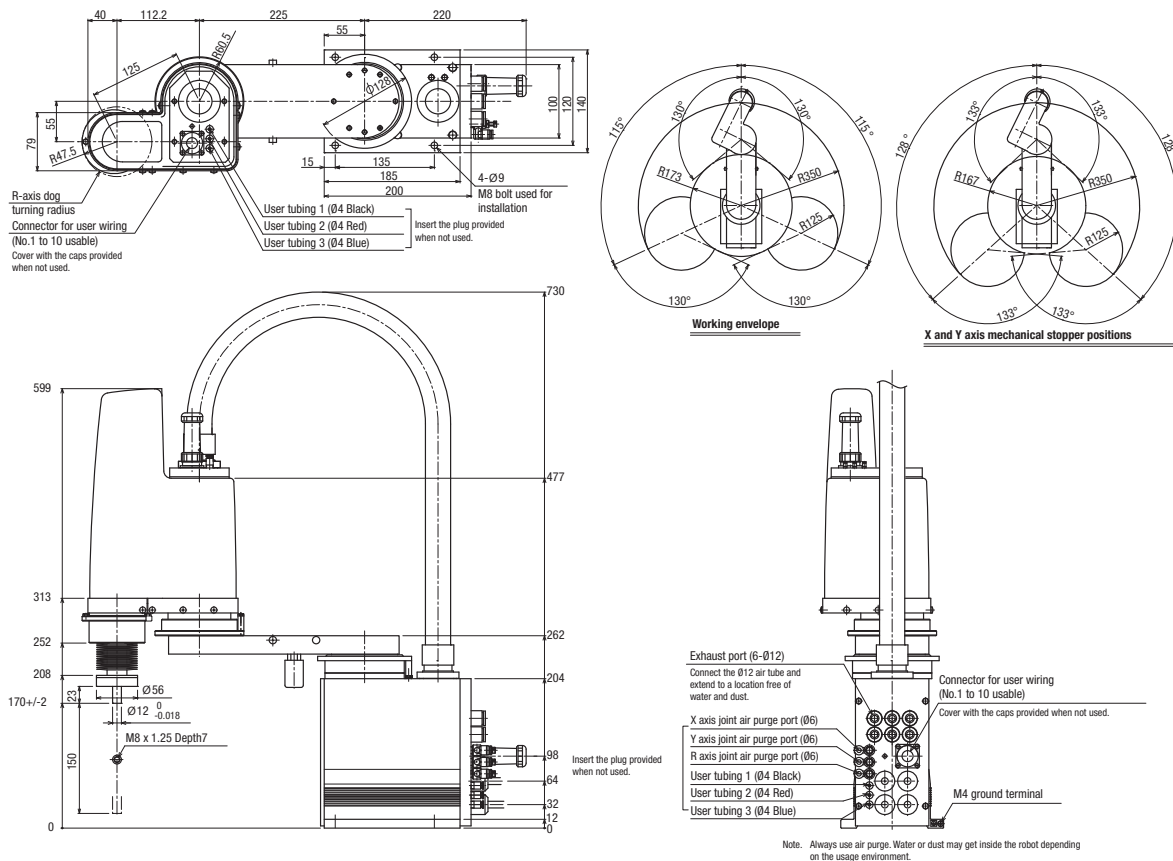

R6YXP400 DUST-PROOF & DRIP-PROOF TYPE

Specifications

		X axis	Y axis	Z axis	R axis
Reach (mm)		400			
Maximum payload (kg)		3			
Repeatability ^{*1} (XYZ:mm) (R:°)		+/-0.01		+/-0.01	+/-0.005
Axis specifications	Arm length (mm)	225	175	150	----
	Rotation range (°)	+/-115	+/-140	----	+/-360
Deceleration mechanism	Speed reducer	Harmonic drive	Harmonic drive	Ball screw	Harmonic drive
	Transmission method	Motor to speed reducer	Direct-coupled	Timing belt transmission	Timing belt transmission
		Speed reducer to output	Direct-coupled		
AC servo motor output (W)		200	100	100	100
Maximum speed (XYZ:m/sec) (R:°/sec)		6		1	1020
Standard cycle time: with 2kg payload ^{*2} (sec)		0.66			
R axis allowable moment inertia ^{*3} (kgm ²)		0.05			
User wiring (sq x pcs)		0.2 x 10			
User tubing (Outer diameter)		Ø4 x 3			
Movement limit setting		1.Soft limit 2.Mechanical stopper (X, Y, Z axis)			
Robot cable length (m)		Standard: 3.5 Option: 5, 10			
Weight (kg) (Excluding robot cable)		15			

- *1 This is the value at a constant ambient temperature. (X,Y axes)
- *2 When moving 25mm in vertical direction and 300mm in horizontal direction reciprocally.
- *3 There are limits to the setting of the acceleration coefficient.

Controller

Controller	Power consumption (VA)	Operating method
YRC	1000	Programming / I/O point trace / Remote command / Operation using RS-232C communication

Ordering information

Description	Model
SCARA Reach: 400mm, Vertical Stroke: 150mm, Max. payload: 3kg, Protection class: IP65	R6YXP400150YRC

Dimensions

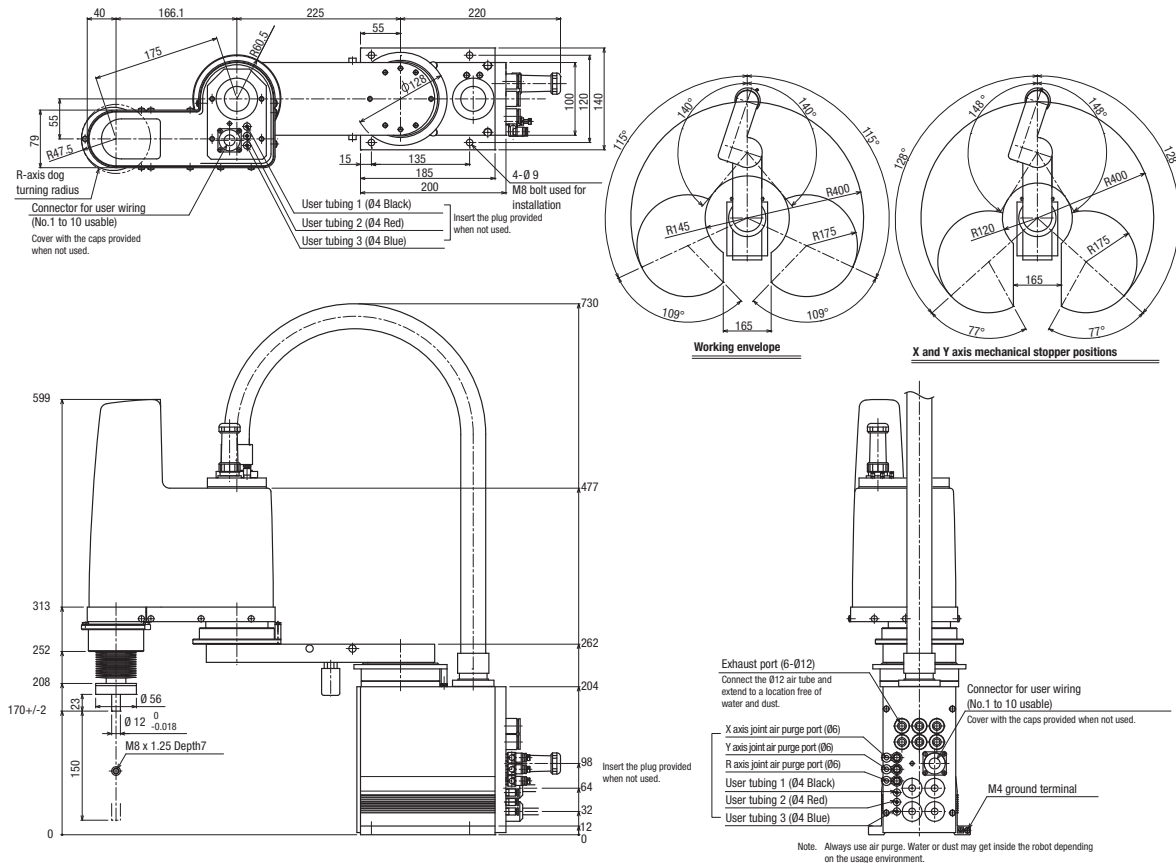

R6YXP500 DUST-PROOF & DRIP-PROOF TYPE

Specifications

	X axis	Y axis	Z axis	R axis
Reach (mm)	500			
Maximum payload (kg)	10			
Repeatability ^{*1} (XYZ:mm) (R:°)	+/-0.02		+/-0.01	+/-0.005
Axis specifications	Arm length (mm)	250	200	300
	Rotation range (°)	+/-120	+/-145	----
Deceleration mechanism	Speed reducer	Harmonic drive	Harmonic drive	Ball screw
	Transmission method	Motor to speed reducer	Direct-coupled	Timing belt transmission
		Speed reducer to output	Direct-coupled	Timing belt transmission
AC servo motor output (W)	400	200	200	100
Maximum speed (XYZ:m/sec) (R:°/sec)	4.9		1.7	876
Standard cycle time: with 2kg payload ^{*2} (sec)	0.53			
R axis allowable moment inertia ^{*3} (kgm ²)	0.12			
User wiring (sq x pcs)	0.2 x 20			
User tubing (Outer diameter)	Ø6 x 3			
Movement limit setting	1.Soft limit 2.Mechanical stopper (X, Y, Z axis)			
Robot cable length (m)	Standard: 3.5 Option: 5, 10			
Weight (kg) (Excluding robot cable)	30			

- *1 This is the value at a constant ambient temperature. (X,Y axes)
- *2 When moving 25mm in vertical direction and 300mm in horizontal direction reciprocally.
- *3 There are limits to the setting of the acceleration coefficient.

Controller

Controller	Power consumption (VA)	Operating method
YRC	1500	Programming / I/O point trace / Remote command / Operation using RS-232C communication

Ordering information

Description	Model
SCARA Reach: 500mm, Vertical Stroke: 200mm, Max. payload: 10kg, Protection class: IP65	R6YXP500200YRC
SCARA Reach: 500mm, Vertical Stroke: 300mm, Max. payload: 10kg, Protection class: IP65	R6YXP500300YRC

Dimensions

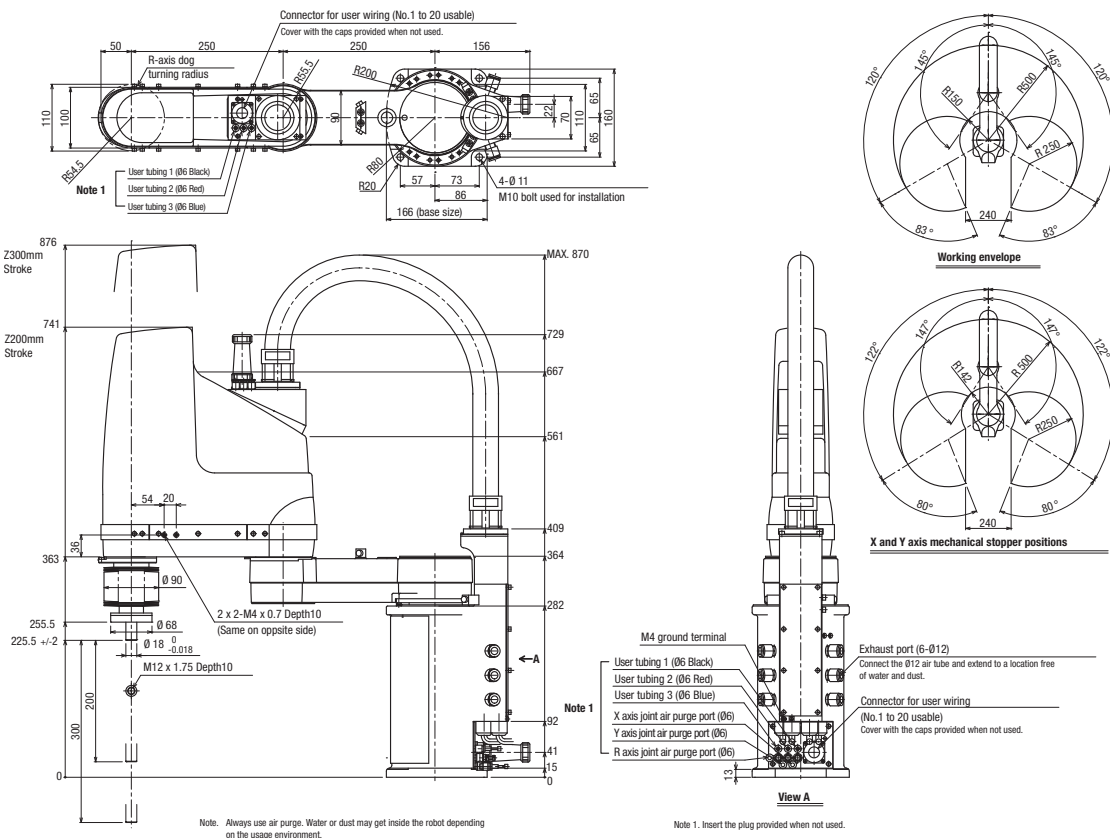

R6YXP600 DUST-PROOF & DRIP-PROOF TYPE

Specifications

		X axis	Y axis	Z axis	R axis
Reach (mm)		600			
Maximum payload (kg)		10			
Repeatability ^{*1} (XYZ:mm) (R:°)		+/-0.02		+/-0.01	+/-0.005
Axis specifications	Arm length (mm)	350	250	200	300
	Rotation range (°)	+/-120	+/-145	----	+/-360
Deceleration mechanism	Speed reducer	Harmonic drive	Harmonic drive	Ball screw	Harmonic drive
	Transmission method	Motor to speed reducer	Direct-coupled	Timing belt transmission	Timing belt transmission
		Speed reducer to output	Direct-coupled		
AC servo motor output (W)		400	200	200	100
Maximum speed (XYZ:m/sec) (R:°/sec)		5.6		1.7	876
Standard cycle time: with 2kg payload ^{*2} (sec)		0.56			
R axis allowable moment inertia ^{*3} (kgm ²)		0.12			
User wiring (sq x pcs)		0.2 x 20			
User tubing (Outer diameter)		Ø6 x 3			
Movement limit setting		1.Soft limit 2.Mechanical stopper (X, Y, Z axis)			
Robot cable length (m)		Standard: 3.5 Option: 5, 10			
Weight (kg) (Excluding robot cable)		32			

- *1 This is the value at a constant ambient temperature. (X, Y axes)
- *2 When moving 25mm in vertical direction and 300mm in horizontal direction reciprocally.
- *3 There are limits to the setting of the acceleration coefficient.

Controller

Controller	Power consumption (VA)	Operating method
YRC	1500	Programming / I/O point trace / Remote command / Operation using RS-232C communication

Ordering information

Description	Model
SCARA Reach: 600mm, Vertical Stroke: 200mm, Max. payload: 10kg, Protection class: IP65	R6YXP600200YRC
SCARA Reach: 600mm, Vertical Stroke: 300mm, Max. payload: 10kg, Protection class: IP65	R6YXP600300YRC

Dimensions

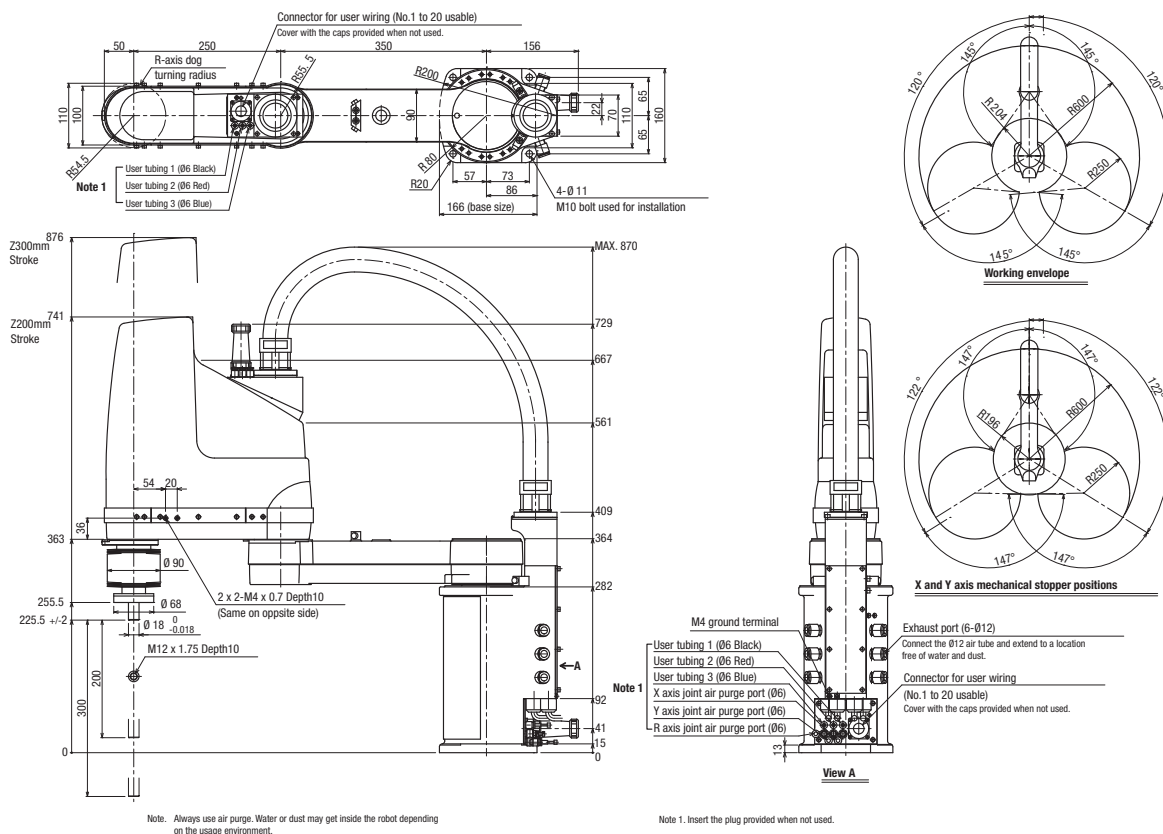

R6YXP800 DUST-PROOF & DRIP-PROOF TYPE

Specifications

		X axis	Y axis	Z axis	R axis
Reach (mm)		800			
Maximum payload (kg)		20			
Repeatability ^{*1} (XYZ:mm) (R:°)		+/-0.02		+/-0.01	+/-0.005
Axis specifications	Arm length (mm)	450	350	200	400
	Rotation range (°)	+/-120	+/-145	----	+/-360
Deceleration mechanism	Speed reducer	Harmonic drive	Harmonic drive	Ball screw	Harmonic drive
	Transmission method	Motor to speed reducer	Direct-coupled	Timing belt transmission	Timing belt transmission
		Speed reducer to output	Direct-coupled		
AC servo motor output (W)		800	400	400	200
Maximum speed (XYZ:m/sec) (R:°/sec)		7.3		1.7	600
Standard cycle time: with 2kg payload ^{*2} (sec)		0.57			
R axis allowable moment inertia ^{*3} (kgm ²)		0.32			
User wiring (sq x pcs)		0.2 x 20			
User tubing (Outer diameter)		Ø6 x 3			
Movement limit setting		1.Soft limit 2.Mechanical stopper (X, Y, Z axis)			
Robot cable length (m)		Standard: 3.5 Option: 5, 10			
Weight (kg) (Excluding robot cable)		57			

- *1 This is the value at a constant ambient temperature. (X, Y axes)
- *2 When moving 25mm in vertical direction and 300mm in horizontal direction reciprocally.
- *3 There are limits to the setting of the acceleration coefficient.

Controller

Controller	Power consumption (VA)	Operating method
YRC	2000	Programming / I/O point trace / Remote command / Operation using RS-232C communication

Ordering information

Description	Model
SCARA Reach: 800mm, Vertical Stroke: 200mm, Max. payload: 20kg, Protection class: IP65	R6YXP800200YRC
SCARA Reach: 800mm, Vertical Stroke: 400mm, Max. payload: 20kg, Protection class: IP65	R6YXP800400YRC

Dimensions

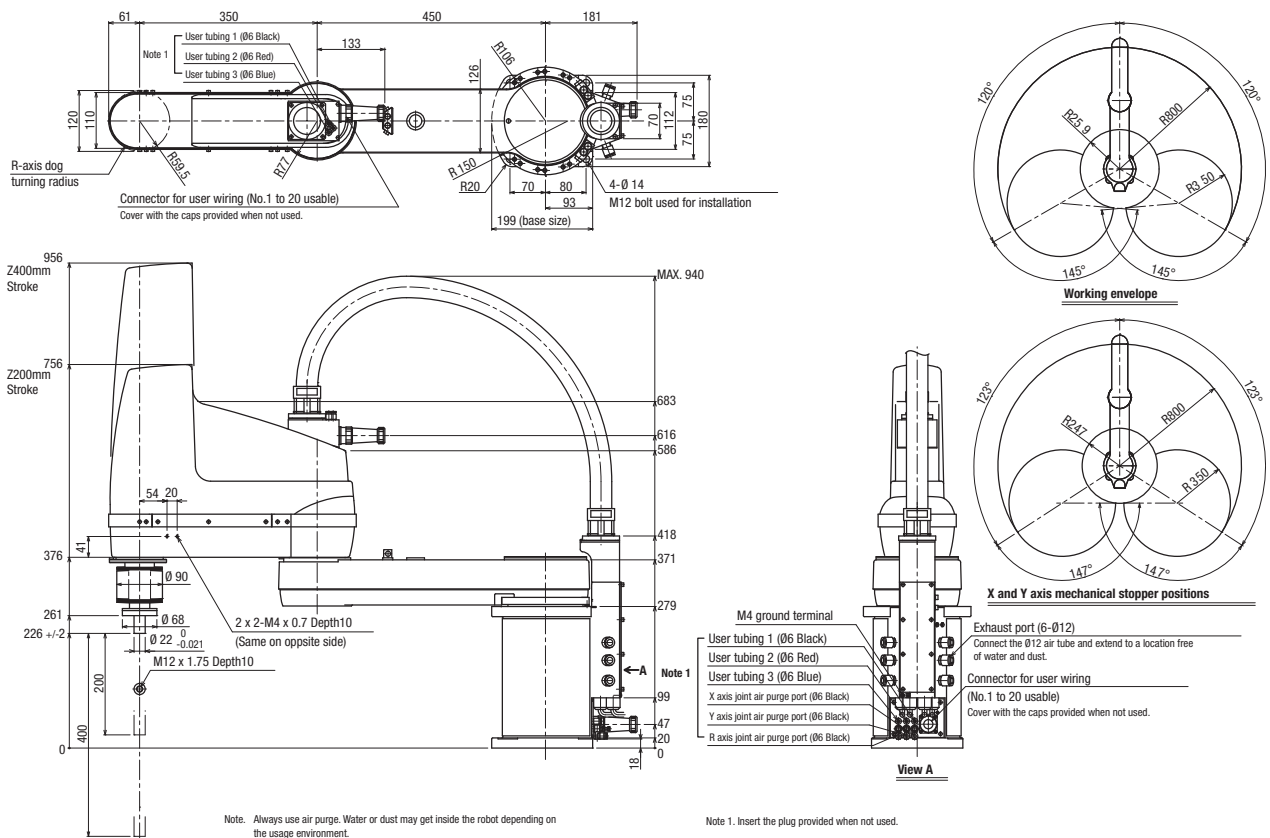

R6YXP1000 DUST-PROOF & DRIP-PROOF TYPE

Specifications

	X axis	Y axis	Z axis	R axis
Reach (mm)	1000			
Maximum payload (kg)	20			
Repeatability ^{*1} (XYZ:mm) (R:°)	+/-0.02		+/-0.01	+/-0.005
Axis specifications	Arm length (mm)	550	200	400
	Rotation range (°)	+/-120	+/-145	----
Deceleration mechanism	Speed reducer	Harmonic drive	Harmonic drive	Ball screw
	Transmission method	Motor to speed reducer	Direct-coupled	Timing belt transmission
		Speed reducer to output	Direct-coupled	Timing belt transmission
AC servo motor output (W)	800	400	400	200
Maximum speed (XYZ:m/sec) (R:°/sec)	8		1.7	600
Standard cycle time: with 2kg payload ^{*2} (sec)	0.6			
R axis allowable moment inertia ^{*3} (kgm ²)	0.32			
User wiring (sq x pcs)	0.2 x 20			
User tubing (Outer diameter)	Ø6 x 3			
Movement limit setting	1.Soft limit 2.Mechanical stopper (X, Y, Z axis)			
Robot cable length (m)	Standard: 3.5 Option: 5, 10			
Weight (kg) (Excluding robot cable)	58			

*1 This is the value at a constant ambient temperature. (X,Y axes)
 *2 When moving 25mm in vertical direction and 300mm in horizontal direction reciprocally.
 *3 There are limits to the setting of the acceleration coefficient.

Controller

Controller	Power consumption (VA)	Operating method
YRC	2000	Programming / I/O point trace / Remote command / Operation using RS-232C communication

Ordering information

Description	Model
SCARA Reach: 1000mm, Vertical Stroke: 200mm, Max. payload: 20kg, Protection class: IP65	R6YXP1000200YRC
SCARA Reach: 1000mm, Vertical Stroke: 400mm, Max. payload: 20kg, Protection class: IP65	R6YXP1000400YRC

Dimensions

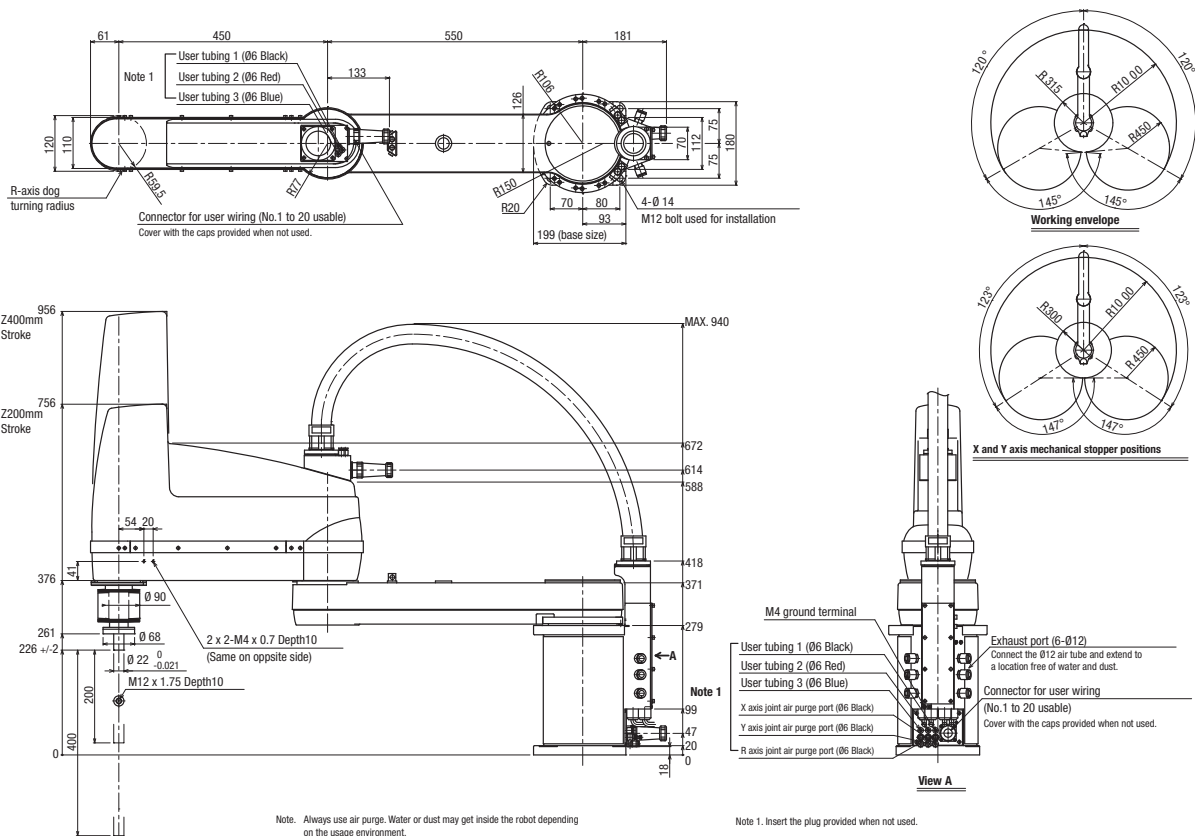

Note. Always use air purge. Water or dust may get inside the robot depending on the usage environment.

Note 1. Insert the plug provided when not used.

R6YXSH300 WALL-HANGING / INVERSE TYPE

Specifications

		X axis	Y axis	Z axis	R axis
Reach (mm)		300			
Maximum payload (kg)		3			
Repeatability ^{*1} (XYZ:mm) (R:°)		+/-0.01		+/-0.01	+/-0.005
Axis specifications	Arm length (mm)	175	125	150	----
	Rotation range (°)	+/-115	+/-140	----	+/-360
Deceleration mechanism	Speed reducer	Harmonic drive	Harmonic drive	Ball screw	Harmonic drive
	Transmission method	Motor to speed reducer	Direct-coupled	Timing belt transmission	Timing belt transmission
		Speed reducer to output	Direct-coupled		
AC servo motor output (W)		200	100	100	100
Maximum speed (XYZ:m/sec) (R:°/sec)		4.4		1	1020
Standard cycle time: with 2kg payload ^{*2} (sec)		0.54			
R axis allowable moment inertia ^{*3} (kgm ²)		0.05			
User wiring (sq x pcs)		0.2 x 10			
User tubing (Outer diameter)		Ø4 x 3			
Movement limit setting		1.Soft limit 2.Mechanical stopper (X, Y, Z axis)			
Robot cable length (m)		Standard: 3.5 Option: 5, 10			
Weight (kg) (Excluding robot cable)		15			

- *1 This is the value at a constant ambient temperature. (X,Y axes)
- *2 When moving 25 mm in vertical direction and 300 mm in horizontal direction reciprocally.
- *3 There are limits to the setting of the acceleration coefficient.

Controller

Controller	Power consumption (VA)	Operating method
YRC	1000	Programming / I/O point trace / Remote command / Operation using RS-232C communication

Ordering information

Description	Model
SCARA Reach: 300mm, Vertical Stroke: 150mm, Max. payload: 3kg.	R6YXSH300150YRC

Dimensions

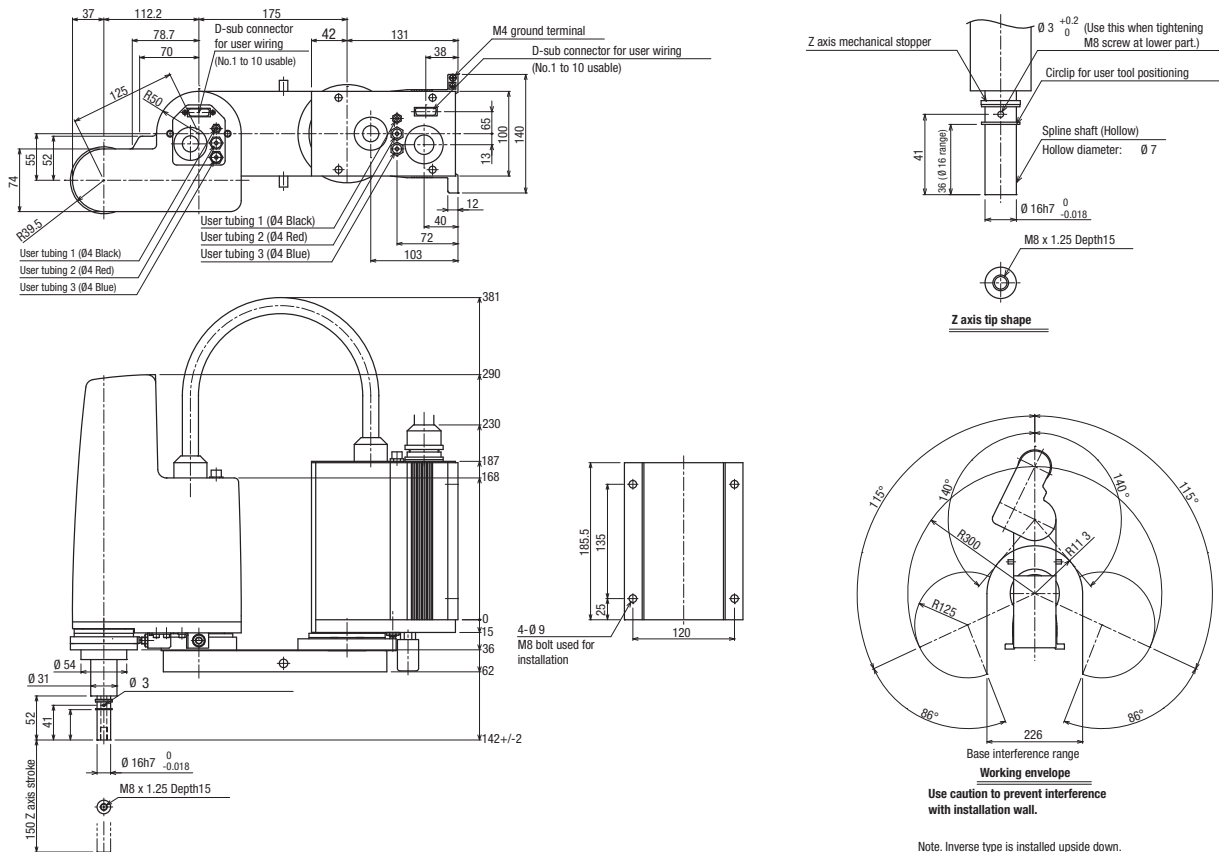

R6YXS500 CEILING-HANGING / INVERSE TYPE

Specifications

		X axis	Y axis	Z axis	R axis
Reach (mm)		500			
Maximum payload (kg)		10			
Repeatability ^{*1} (XYZ:mm) (R:°)		+/-0.02		+/-0.01	+/-0.005
Axis specifications	Arm length (mm)	250	250	200	300
	Rotation range (°)	+/-120	+/-135	----	+/-360
Deceleration mechanism	Speed reducer	Harmonic drive	Harmonic drive	Ball screw	Harmonic drive
	Transmission method	Motor to speed reducer	Direct-coupled	Timing belt transmission	Timing belt transmission
		Speed reducer to output	Direct-coupled		
AC servo motor output (W)		400	200	200	100
Maximum speed (XYZ:m/sec) (R:°/sec)		4.9		1.7	876
Standard cycle time: with 2kg payload ^{*2} (sec)		0.53			
R axis allowable moment inertia ^{*3} (kgm ²)		0.12			
User wiring (sq x pcs)		0.2 x 20			
User tubing (Outer diameter)		Ø6 x 3			
Movement limit setting		1.Soft limit 2.Mechanical stopper (X, Y, Z axis)			
Robot cable length (m)		Standard: 3.5 Option: 5, 10			
Weight (kg) (Excluding robot cable)		30			

- *1 This is the value at a constant ambient temperature. (X,Y axes)
- *2 When moving 25 mm in vertical direction and 300 mm in horizontal direction reciprocally.
- *3 There are limits to the setting of the acceleration coefficient.

Controller

Controller	Power consumption (VA)	Operating method
YRC	1500	Programming / I/O point trace / Remote command / Operation using RS-232C communication

Ordering information

Description	Model
SCARA Reach: 500 mm, Vertical Stroke: 200 mm, Max. payload: 10 kg.	R6YXS500200YRC
SCARA Reach: 500 mm, Vertical Stroke: 300 mm, Max. payload: 10 kg.	R6YXS500300YRC

Dimensions

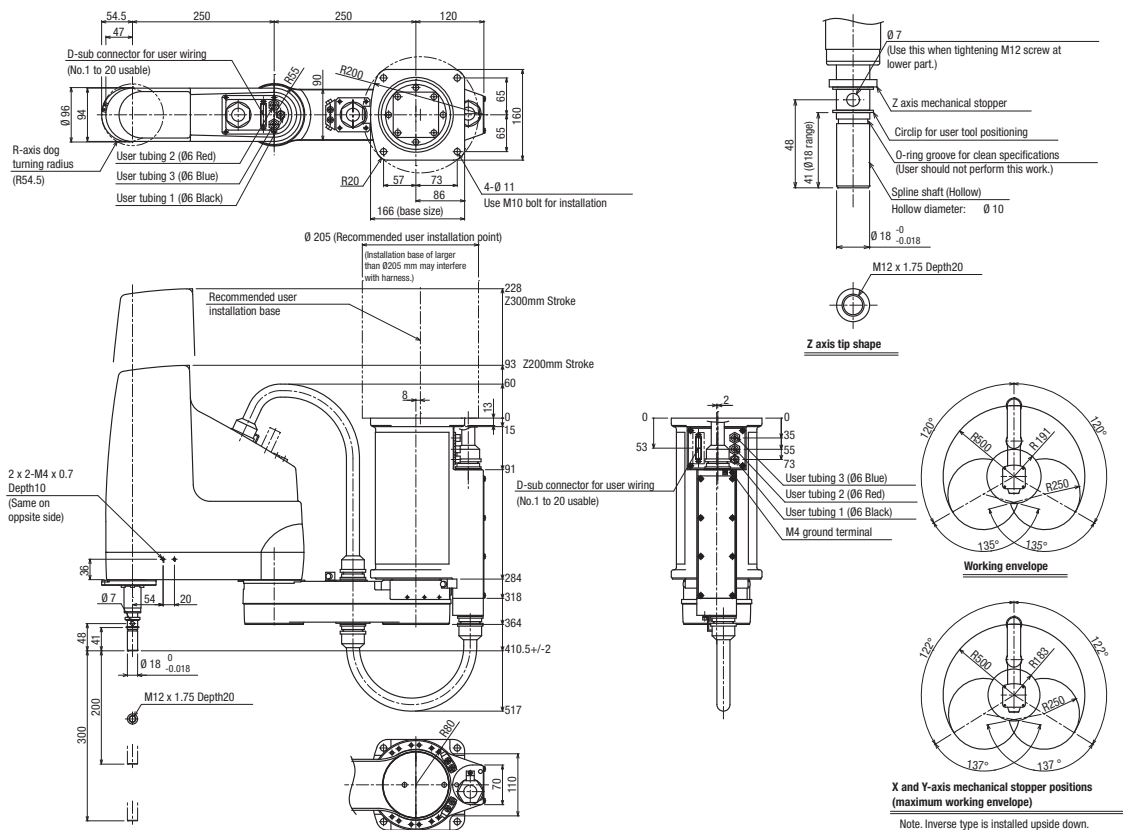

R6YXS600 CEILING-HANGING / INVERSE TYPE

Specifications

		X axis	Y axis	Z axis	R axis
Reach (mm)		600			
Maximum payload (kg)		10			
Repeatability ^{*1} (XYZ:mm) (R:°)		+/-0.02		+/-0.01	+/-0.005
Axis specifications	Arm length (mm)	350	250	200	300
	Rotation range (°)	+/-120	+/-145	----	+/-360
Deceleration mechanism	Speed reducer	Harmonic drive	Harmonic drive	Ball screw	Harmonic drive
	Transmission method	Motor to speed reducer	Direct-coupled	Timing belt transmission	Timing belt transmission
		Speed reducer to output	Direct-coupled		
AC servo motor output (W)		400	200	200	100
Maximum speed (XYZ:m/sec) (R:°/sec)		5.6		1.7	876
Standard cycle time: with 2kg payload ^{*2} (sec)		0.56			
R axis allowable moment inertia ^{*3} (kgm ²)		0.12			
User wiring (sq x pcs)		0.2 x 20			
User tubing (Outer diameter)		Ø6 x 3			
Movement limit setting		1.Soft limit 2.Mechanical stopper (X, Y, Z axis)			
Robot cable length (m)		Standard: 3.5 Option: 5, 10			
Weight (kg) (Excluding robot cable)		32			

*1 This is the value at a constant ambient temperature. (X,Y axes)
 *2 When moving 25 mm in vertical direction and 300 mm in horizontal direction reciprocally.
 *3 There are limits to the setting of the acceleration coefficient.

Controller

Controller	Power consumption (VA)	Operating method
YRC	1500	Programming / I/O point trace / Remote command / Operation using RS-232C communication

Ordering information

Description	Model
SCARA Reach: 600 mm, Vertical Stroke: 200 mm, Max. payload: 10 kg.	R6YXS600200YRC
SCARA Reach: 600 mm, Vertical Stroke: 300 mm, Max. payload: 10 kg.	R6YXS600300YRC

Dimensions

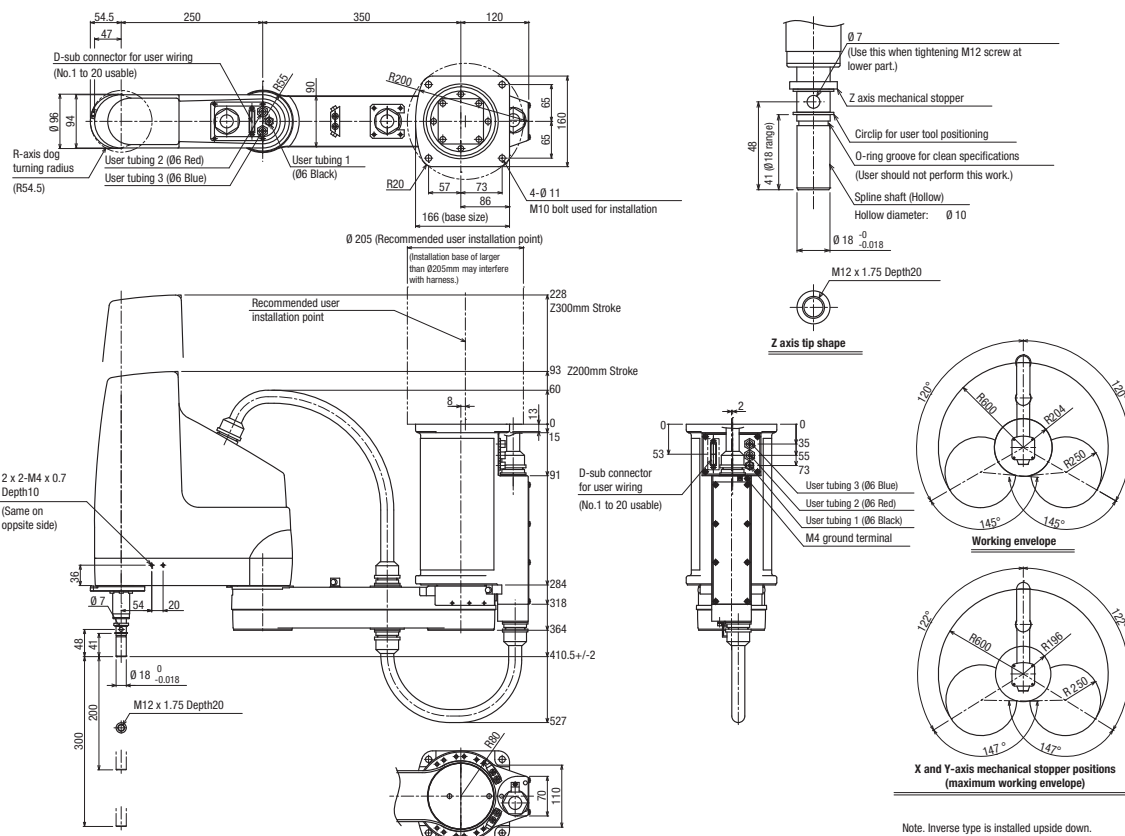

R6YXS700 CEILING-HANGING / INVERSE TYPE

Specifications

		X axis	Y axis	Z axis	R axis
Reach (mm)		700			
Maximum payload (kg)		20			
Repeatability ^{*1} (XYZ:mm) (R:°)		+/-0.02		+/-0.01	+/-0.005
Axis specifications	Arm length (mm)	350	350	200	400
	Rotation range (°)	+/-120	+/-145	----	+/-360
Deceleration mechanism	Speed reducer	Harmonic drive	Harmonic drive	Ball screw	Harmonic drive
	Transmission method	Motor to speed reducer	Direct-coupled	Timing belt transmission	Timing belt transmission
		Speed reducer to output	Direct-coupled		
AC servo motor output (W)		800	400	400	200
Maximum speed (XYZ:m/sec) (R:°/sec)		6.7		1.7	600
Standard cycle time: with 2kg payload ^{*2} (sec)		0.57			
R axis allowable moment inertia ^{*3} (kgm ²)		0.32			
User wiring (sq x pcs)		0.2 x 20			
User tubing (Outer diameter)		Ø6 x 3			
Movement limit setting		1.Soft limit 2.Mechanical stopper (X, Y, Z axis)			
Robot cable length (m)		Standard: 3.5 Option: 5, 10			
Weight (kg) (Excluding robot cable)		56			

- *1 This is the value at a constant ambient temperature. (X,Y axes)
- *2 When moving 25mm in vertical direction and 300mm in horizontal direction reciprocally.
- *3 There are limits to the setting of the acceleration coefficient.

Controller

Controller	Power consumption (VA)	Operating method
YRC	2000	Programming / I/O point trace / Remote command / Operation using RS-232C communication

Ordering information

Description	Model
SCARA Reach: 700mm, Vertical Stroke: 200mm, Max. payload: 20kg.	R6YXS700200YRC
SCARA Reach: 700mm, Vertical Stroke: 400mm, Max. payload: 20kg.	R6YXS700400YRC

Dimensions

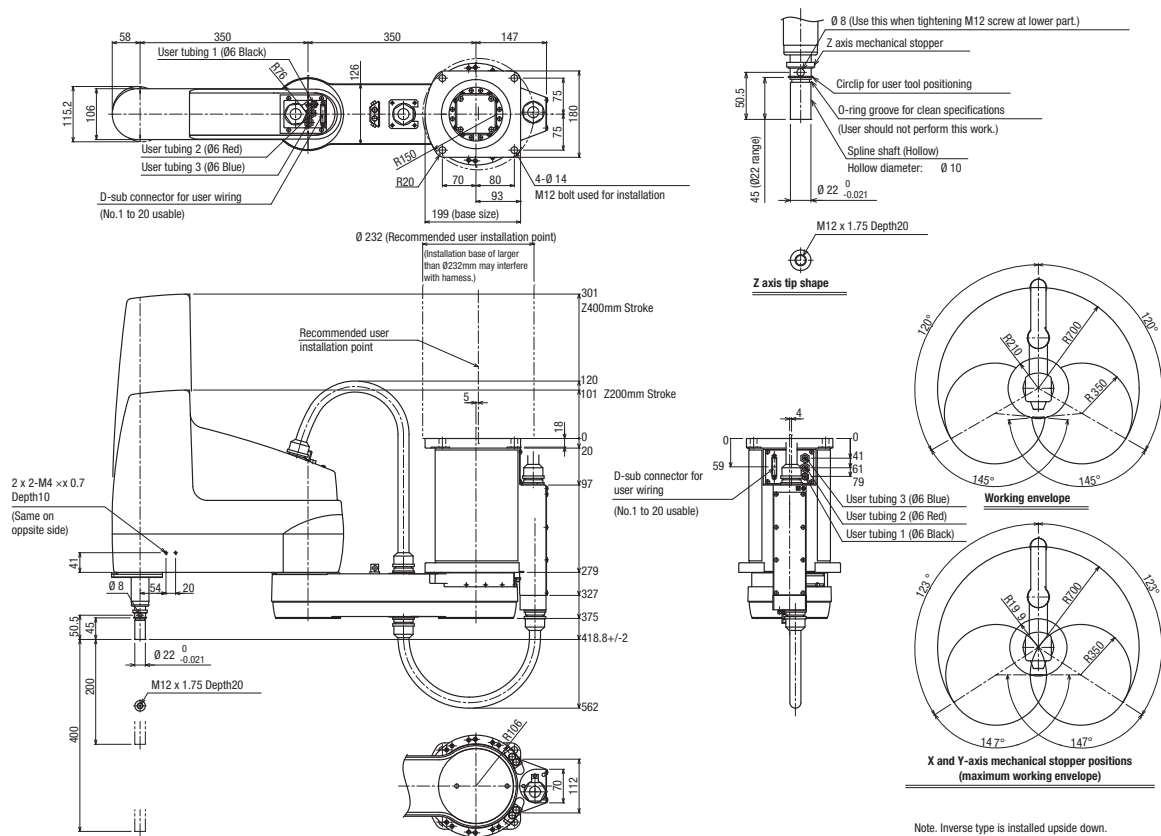

Note. Inverse type is installed upside down.

R6YXS800 CEILING-HANGING / INVERSE TYPE

Specifications

		X axis	Y axis	Z axis	R axis
Reach (mm)		800			
Maximum payload (kg)		20			
Repeatability ^{*1} (XYZ:mm) (R:°)		+/-0.02		+/-0.01	+/-0.005
Axis specifications	Arm length (mm)	450	350	200	400
	Rotation range (°)	+/-120	+/-145	----	+/-360
Deceleration mechanism	Speed reducer	Harmonic drive	Harmonic drive	Ball screw	Harmonic drive
	Transmission method	Motor to speed reducer	Direct-coupled		Timing belt transmission
		Speed reducer to output	Direct-coupled		
AC servo motor output (W)		800	400	400	200
Maximum speed (XYZ:m/sec) (R:°/sec)		7.3		1.7	600
Standard cycle time: with 2kg payload ^{*2} (sec)		0.57			
R axis allowable moment inertia ^{*3} (kgm ²)		0.32			
User wiring (sq x pcs)		0.2 x 20			
User tubing (Outer diameter)		Ø6 x 3			
Movement limit setting		1.Soft limit 2.Mechanical stopper (X, Y, Z axis)			
Robot cable length (m)		Standard: 3.5 Option: 5, 10			
Weight (kg) (Excluding robot cable)		57			

*1 This is the value at a constant ambient temperature. (X,Y axes)
 *2 When moving 25mm in vertical direction and 300mm in horizontal direction reciprocally.
 *3 There are limits to the setting of the acceleration coefficient.

Controller

Controller	Power consumption (VA)	Operating method
YRC	2000	Programming / I/O point trace / Remote command / Operation using RS-232C communication

Ordering information

Description	Model
SCARA Reach: 800mm, Vertical Stroke: 200mm, Max. payload: 20kg.	R6YXS800200YRC
SCARA Reach: 800mm, Vertical Stroke: 400mm, Max. payload: 20kg.	R6YXS800400YRC

Dimensions

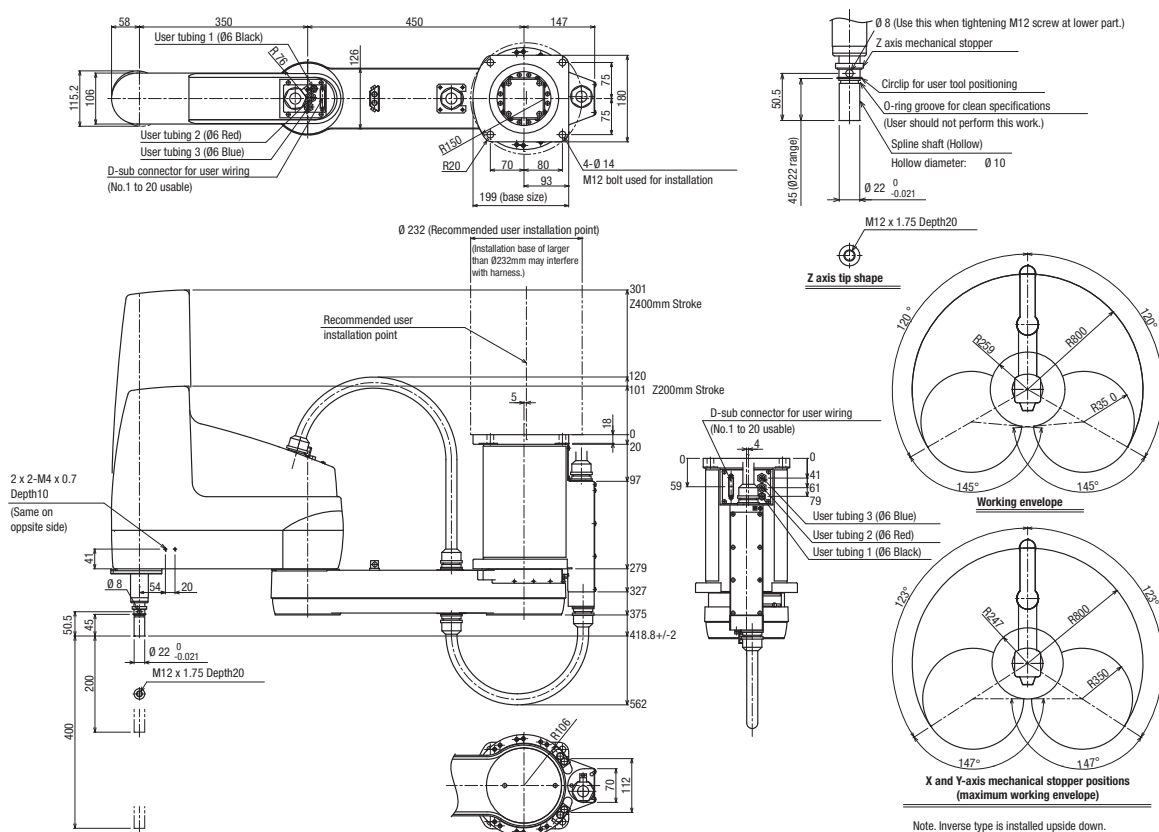

R6YXS1000 CEILING-HANGING / INVERSE TYPE

Specifications

		X axis	Y axis	Z axis	R axis
Reach (mm)		1000			
Maximum payload (kg)		20			
Repeatability ^{*1} (XYZ:mm) (R:°)		+/-0.02		+/-0.01	+/-0.005
Axis specifications	Arm length (mm)	550	450	200	400
	Rotation range (°)	+/-120	+/-145	----	+/-360
Deceleration mechanism	Speed reducer	Harmonic drive	Harmonic drive	Ball screw	Harmonic drive
	Transmission method	Motor to speed reducer	Direct-coupled	Timing belt transmission	Timing belt transmission
		Speed reducer to output	Direct-coupled		
AC servo motor output (W)		800	400	400	200
Maximum speed (XYZ:m/sec) (R:°/sec)		8		1.7	600
Standard cycle time: with 2kg payload ^{*2} (sec)		0.6			
R axis allowable moment inertia ^{*3} (kgm ²)		0.32			
User wiring (sq x pcs)		0.2 x 20			
User tubing (Outer diameter)		Ø6 x 3			
Movement limit setting		1.Soft limit 2.Mechanical stopper (X, Y, Z axis)			
Robot cable length (m)		Standard: 3.5 Option: 5, 10			
Weight (kg) (Excluding robot cable)		58			

*1 This is the value at a constant ambient temperature. (X,Y axes)

*2 When moving 25mm in vertical direction and 300mm in horizontal direction reciprocally.

*3 There are limits to the setting of the acceleration coefficient.

Controller

Controller	Power consumption (VA)	Operating method
YRC	2000	Programming / I/O point trace / Remote command / Operation using RS-232C communication

Ordering information

Description	Model
SCARA Reach: 1000mm, Vertical Stroke: 200mm, Max. payload: 20kg.	R6YXS1000200YRC
SCARA Reach: 1000mm, Vertical Stroke: 400mm, Max. payload: 20kg.	R6YXS1000400YRC

Dimensions

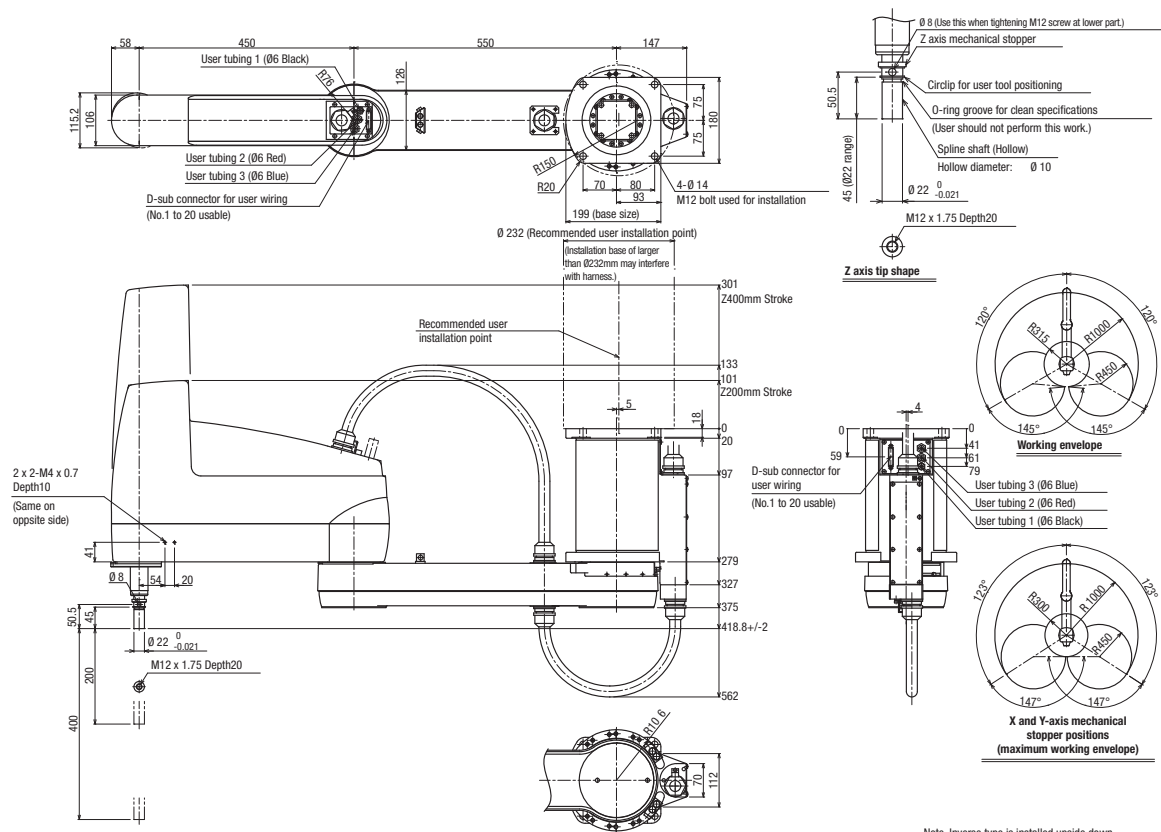

Note. Inverse type is installed upside down.

SCARA robot series

Ordering information

XG series

	Series	Reach (mm)	Z-axis stroke (mm)	Payload (kg)	Robot item code	RGU	Robot cable length (m)	Cable item code	Detachable robot cable
R6Y	XG	120	50	1	R6YXG12050YRC	N.A.	2.0	R6YACCX002T1	N.A.
							3.5	R6YACCX003T1	N.A.
							5.0	R6YACCX005T1	N.A.
							10.0	R6YACCX010T1	N.A.
	XG	150	50	1	R6YXG15050YRC	N.A.	2.0	R6YACCX002T1	N.A.
							3.5	R6YACCX003T1	N.A.
							5.0	R6YACCX005T1	N.A.
							10.0	R6YACCX010T1	N.A.
	XG	180	50	1	R6YXG18050YRC	N.A.	2.0	R6YACCX002T1	N.A.
							3.5	R6YACCX003T1	N.A.
							5.0	R6YACCX005T1	N.A.
							10.0	R6YACCX010T1	N.A.
	XG	220	100	1	R6YXG220100YRC	N.A.	3.5	R6YACCX003T2	N.A.
							5.0	R6YACCX005T2	N.A.
							10.0	R6YACCX010T2	N.A.
	XG	500	200	10	R6YXG500200YRC	RGU3	3.5	R6YACCX003XGX	●
							5.0	R6YACCX005XGX	●
							10.0	R6YACCX010XGX	●
			300	10	R6YXG500300YRC	RGU3	3.5	R6YACCX003XGX	●
							5.0	R6YACCX005XGX	●
							10.0	R6YACCX010XGX	●
	XG	600	200	10	R6YXG600200YRC	RGU3	3.5	R6YACCX003XGX	●
							5.0	R6YACCX005XGX	●
							10.0	R6YACCX010XGX	●
			300	10	R6YXG600300YRC	RGU3	3.5	R6YACCX003XGX	●
							5.0	R6YACCX005XGX	●
							10.0	R6YACCX010XGX	●
	XGH	600	200	20	R6YXGH600200YRC	RGU3	3.5	R6YACCX003XGX	●
							5.0	R6YACCX005XGX	●
							10.0	R6YACCX010XGX	●
			400	20	R6YXGH600400YRC	RGU3	3.5	R6YACCX003XGX	●
							5.0	R6YACCX005XGX	●
							10.0	R6YACCX010XGX	●
	XG	700	200	20	R6YXG700200YRC	RGU3	3.5	R6YACCX003XGX	●
							5.0	R6YACCX005XGX	●
							10.0	R6YACCX010XGX	●
			400	20	R6YXG700400YRC	RGU3	3.5	R6YACCX003XGX	●
							5.0	R6YACCX005XGX	●
							10.0	R6YACCX010XGX	●
	XG	800	200	20	R6YXG800200YRC	RGU3	3.5	R6YACCX003XGX	●
							5.0	R6YACCX005XGX	●
							10.0	R6YACCX010XGX	●
400			20	R6YXG800400YRC	RGU3	3.5	R6YACCX003XGX	●	
						5.0	R6YACCX005XGX	●	
						10.0	R6YACCX010XGX	●	
XG	900	200	20	R6YXG900200YRC	RGU3	3.5	R6YACCX003XGX	●	
						5.0	R6YACCX005XGX	●	
						10.0	R6YACCX010XGX	●	
		400	20	R6YXG900400YRC	RGU3	3.5	R6YACCX003XGX	●	
						5.0	R6YACCX005XGX	●	
						10.0	R6YACCX010XGX	●	
XG	1000	200	20	R6YXG1000200YRC	RGU3	3.5	R6YACCX003XGX	●	
						5.0	R6YACCX005XGX	●	
						10.0	R6YACCX010XGX	●	
		400	20	R6YXG1000400YRC	RGU3	3.5	R6YACCX003XGX	●	
						5.0	R6YACCX005XGX	●	
						10.0	R6YACCX010XGX	●	

X series

	Series	Reach (mm)	Z-axis stroke (mm)	Payload (kg)	Robot item code	RGU	Robot cable length (m)	Cable item code	Detachable robot cable
R6Y	XH	250	150	3	R6YXH250150YRC	N.A.	3.5	R6YACCX003XGX	●
							5.0	R6YACCX005XGX	●
							10.0	R6YACCX010XGX	●
	XH	350	150	3	R6YXH350150YRC	N.A.	3.5	R6YACCX003XGX	●
							5.0	R6YACCX005XGX	●
							10.0	R6YACCX010XGX	●
	XH	400	150	3	R6YXH400150YRC	N.A.	3.5	R6YACCX003XGX	●
							5.0	R6YACCX005XGX	●
							10.0	R6YACCX010XGX	●
	XX	1200	400	50	R6YXX1200400YRC	RGU2	3.5	R6YACCX003XGX	●
							5.0	R6YACCX005XGX	●
							10.0	R6YACCX010XGX	●

XC series - Clean type

	Series	Reach (mm)	Z-axis stroke (mm)	Payload (kg)	Robot item code	RGU	Robot cable length (m)	Cable item code	Detachable robot cable	
R6Y	XC	180	100	1	R6YXC180100YRC	N.A.	3.5	R6YACCX003XSXC	N.A.	
							5.0	R6YACCX005XSXC	N.A.	
							10.0	R6YACCX010XSXC	N.A.	
	XC	220	100	1	R6YXC220100YRC	N.A.	3.5	R6YACCX003XSXC	N.A.	
							5.0	R6YACCX005XSXC	N.A.	
							10.0	R6YACCX010XSXC	N.A.	
	XCH	250	150	3	R6YXCH250150YRC	N.A.	3.5	R6YACCX003XSXC	N.A.	
							5.0	R6YACCX005XSXC	N.A.	
							10.0	R6YACCX010XSXC	N.A.	
	XCH	350	150	3	R6YXCH350150YRC	N.A.	3.5	R6YACCX003XSXC	N.A.	
							5.0	R6YACCX005XSXC	N.A.	
							10.0	R6YACCX010XSXC	N.A.	
	XCH	400	150	3	R6YXCH400150YRC	N.A.	3.5	R6YACCX003XSXC	N.A.	
							5.0	R6YACCX005XSXC	N.A.	
							10.0	R6YACCX010XSXC	N.A.	
	XC	500	200	10	R6YXC500200YRC	RGU2	3.5	R6YACCX003XSXC	N.A.	
							5.0	R6YACCX005XSXC	N.A.	
							10.0	R6YACCX010XSXC	N.A.	
		XC	600	200	10	R6YXC600200YRC	RGU2	3.5	R6YACCX003XSXC	N.A.
								5.0	R6YACCX005XSXC	N.A.
								10.0	R6YACCX010XSXC	N.A.
	XC	700	200	20	R6YXC700200YRC	RGU2	3.5	R6YACCX003XSXC	N.A.	
							5.0	R6YACCX005XSXC	N.A.	
							10.0	R6YACCX010XSXC	N.A.	
	XC	800	200	20	R6YXC800200YRC	RGU2	3.5	R6YACCX003XSXC	N.A.	
							5.0	R6YACCX005XSXC	N.A.	
							10.0	R6YACCX010XSXC	N.A.	
		XC	1000	200	20	R6YXC1000200YRC	RGU2	3.5	R6YACCX003XSXC	N.A.
								5.0	R6YACCX005XSXC	N.A.
								10.0	R6YACCX010XSXC	N.A.
	XC	400	20	20	R6YXC800400YRC	RGU2	3.5	R6YACCX003XSXC	N.A.	
							5.0	R6YACCX005XSXC	N.A.	
							10.0	R6YACCX010XSXC	N.A.	
	XC	400	20	20	R6YXC1000400YRC	RGU2	3.5	R6YACCX003XSXC	N.A.	
							5.0	R6YACCX005XSXC	N.A.	
							10.0	R6YACCX010XSXC	N.A.	

XP series - Dust-proof & drip-proof type

	Series	Reach (mm)	Z-axis stroke (mm)	Payload (kg)	Robot item code	RGU	Robot cable length (m)	Cable item code	Detachable robot cable
R6Y	XP	250	150	3	R6YXP250150YRC	N.A.	3.5	R6YACCX003XP	N.A.
							5.0	R6YACCX005XP	N.A.
							10.0	R6YACCX010XP	N.A.
	XP	350	150	3	R6YXP350150YRC	N.A.	3.5	R6YACCX003XP	N.A.
							5.0	R6YACCX005XP	N.A.
							10.0	R6YACCX010XP	N.A.
	XP	400	150	3	R6YXP400150YRC	N.A.	3.5	R6YACCX003XP	N.A.
							5.0	R6YACCX005XP	N.A.
							10.0	R6YACCX010XP	N.A.
	XP	500	200	10	R6YXP500200YRC	RGU2	3.5	R6YACCX003XP	N.A.
							5.0	R6YACCX005XP	N.A.
							10.0	R6YACCX010XP	N.A.
			300	10	R6YXP500300YRC	RGU2	3.5	R6YACCX003XP	N.A.
							5.0	R6YACCX005XP	N.A.
							10.0	R6YACCX010XP	N.A.
	XP	600	200	10	R6YXP600200YRC	RGU2	3.5	R6YACCX003XP	N.A.
							5.0	R6YACCX005XP	N.A.
							10.0	R6YACCX010XP	N.A.
			300	10	R6YXP600300YRC	RGU2	3.5	R6YACCX003XP	N.A.
							5.0	R6YACCX005XP	N.A.
							10.0	R6YACCX010XP	N.A.
	XP	700	200	20	R6YXP700200YRC	RGU2	3.5	R6YACCX003XP	N.A.
							5.0	R6YACCX005XP	N.A.
							10.0	R6YACCX010XP	N.A.
			400	20	R6YXP700400YRC	RGU2	3.5	R6YACCX003XP	N.A.
							5.0	R6YACCX005XP	N.A.
							10.0	R6YACCX010XP	N.A.
	XP	800	200	20	R6YXP800200YRC	RGU2	3.5	R6YACCX003XP	N.A.
							5.0	R6YACCX005XP	N.A.
							10.0	R6YACCX010XP	N.A.
400			20	R6YXP800400YRC	RGU2	3.5	R6YACCX003XP	N.A.	
						5.0	R6YACCX005XP	N.A.	
						10.0	R6YACCX010XP	N.A.	
XP	1000	200	20	R6YXP1000200YRC	RGU2	3.5	R6YACCX003XP	N.A.	
						5.0	R6YACCX005XP	N.A.	
						10.0	R6YACCX010XP	N.A.	
		400	20	R6YXP1000400YRC	RGU2	3.5	R6YACCX003XP	N.A.	
						5.0	R6YACCX005XP	N.A.	
						10.0	R6YACCX010XP	N.A.	

XS series - Ceiling-hanging / wall-hanging / inverse type

	Series	Reach (mm)	Z-axis stroke (mm)	Payload (kg)	Robot item code	RGU	Robot cable length (m)	Cable item code	Detachable robot cable			
R6Y	XSH	300	150	3	R6YXSH300150YRC	N.A.	3.5	R6YACCX003XSXC	N.A.			
							5.0	R6YACCX005XSXC	N.A.			
							10.0	R6YACCX010XSXC	N.A.			
		400	150	3	R6YXSH400150YRC	N.A.	N.A.	3.5	R6YACCX003XSXC	N.A.		
								5.0	R6YACCX005XSXC	N.A.		
								10.0	R6YACCX010XSXC	N.A.		
	XS	500	200	10	R6YXS500200YRC	RGU2	N.A.	3.5	R6YACCX003XSXC	N.A.		
								5.0	R6YACCX005XSXC	N.A.		
								10.0	R6YACCX010XSXC	N.A.		
			300	10	R6YXS500300YRC	RGU2	N.A.	N.A.	3.5	R6YACCX003XSXC	N.A.	
									5.0	R6YACCX005XSXC	N.A.	
									10.0	R6YACCX010XSXC	N.A.	
		600	200	10	R6YXS600200YRC	RGU2	N.A.	N.A.	3.5	R6YACCX003XSXC	N.A.	
									5.0	R6YACCX005XSXC	N.A.	
									10.0	R6YACCX010XSXC	N.A.	
			300	10	R6YXS600300YRC	RGU2	N.A.	N.A.	N.A.	3.5	R6YACCX003XSXC	N.A.
										5.0	R6YACCX005XSXC	N.A.
										10.0	R6YACCX010XSXC	N.A.
		700	200	20	R6YXS700200YRC	RGU2	N.A.	N.A.	3.5	R6YACCX003XSXC	N.A.	
									5.0	R6YACCX005XSXC	N.A.	
									10.0	R6YACCX010XSXC	N.A.	
			400	20	R6YXS700400YRC	RGU2	N.A.	N.A.	N.A.	3.5	R6YACCX003XSXC	N.A.
										5.0	R6YACCX005XSXC	N.A.
										10.0	R6YACCX010XSXC	N.A.
		800	200	20	R6YXS800200YRC	RGU2	N.A.	N.A.	3.5	R6YACCX003XSXC	N.A.	
									5.0	R6YACCX005XSXC	N.A.	
									10.0	R6YACCX010XSXC	N.A.	
			400	20	R6YXS800400YRC	RGU2	N.A.	N.A.	N.A.	3.5	R6YACCX003XSXC	N.A.
										5.0	R6YACCX005XSXC	N.A.
										10.0	R6YACCX010XSXC	N.A.
1000	200	20	R6YXS1000200YRC	RGU2	N.A.	N.A.	3.5	R6YACCX003XSXC	N.A.			
							5.0	R6YACCX005XSXC	N.A.			
							10.0	R6YACCX010XSXC	N.A.			
	400	20	R6YXS1000400YRC	RGU2	N.A.	N.A.	N.A.	3.5	R6YACCX003XSXC	N.A.		
								5.0	R6YACCX005XSXC	N.A.		
								10.0	R6YACCX010XSXC	N.A.		

Industrial robots

ALL DIMENSIONS SHOWN ARE IN MILLIMETERS.
To convert millimeters into inches, multiply by 0.03937. To convert grams into ounces, multiply by 0.03527.

Technical information

Mechatronics formulae

Linear movement

Symbol	Description	Units
s	Space	m
v	Velocity	m/s
a	Acceleration	m/s ²
F	Force	N
P	Power	W
W	Energy	J
t	Time	s
μ	Friction coefficient	--
g	Gravity acceleration	m/s ²
m	Mass	Kg

Speed (m/s)

$$v = \frac{\partial s}{\partial t}$$

Acceleration (m/s²)

$$a = \frac{\partial v}{\partial t}$$

Acceleration force (N)

$$F_a = m \cdot a$$

Force friction (N)

$$F_\mu = \mu \cdot m \cdot g \cdot \cos \beta$$

Force gravity (N)

$$F_g = m \cdot g \cdot \sin \beta$$



Force root means square (N)

$$F_{rms} = \sqrt{\frac{\sum_i t_i \cdot F_i^2}{\sum_i t_i}}$$

Power (W)

$$P = F \cdot v$$

Cynetic energy

$$W = \frac{1}{2} \cdot m \cdot v^2$$

Rotary movement

Symbol	Description	Units
Φ	Angle	rad
ω	Angular velocity	rad/s
α	Angular acceleration	rad/s ²
T	Torque	Nm
P	Power	W
W	Energy	J
t	Time	s
i	Gear reduction	--
r	Radius	m
J	Inertia	Kgm ²

Speed (rad/s)

$$\omega = \frac{\partial \phi}{\partial t}$$

Acceleration (rad/s²)

$$\alpha = \frac{\partial \omega}{\partial t}$$

Acceleration torque (Nm)

$$T_\alpha = J \cdot \alpha$$

Torque root means square (Nm)

$$T_{rms} = \sqrt{\frac{\sum_i t_i \cdot T_i^2}{\sum_i t_i}}$$

Power (W)

$$P = T \cdot \omega$$

Cynetic energy

$$W = \frac{1}{2} \cdot J \cdot \omega^2$$

Example in case of trapezoidal profile (linear):

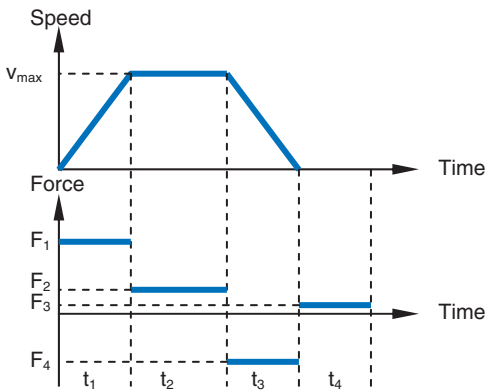

1. Acceleration

$$a = \frac{v_{max}}{t_1}$$

$$s_1 = \frac{1}{2} \cdot v_{max} \cdot t_1$$

$$F_a = m \cdot a$$

$$F_{1_Total} = F_a + F_{\mu} + F_{ext}$$

2. Constant speed

$$a = 0$$

$$s_2 = v_{max} \cdot t_2$$

$$F_{2_Total} = F_{\mu} + F_{ext}$$

3. Deceleration

$$d = \frac{v_{max}}{t_3}$$

$$s_3 = \frac{1}{2} \cdot v_{max} \cdot t_3$$

$$F_d = m \cdot d$$

$$F_{3_Total} = F_{\mu} + F_{ext} - F_d$$

4. Dwell

$$s_4 = 0$$

$$F_{4_Total} = F_{ext}$$

Force rms:

$$F_{rms} = \sqrt{\frac{t_1 \cdot F_1^2 + t_2 \cdot F_2^2 + t_3 \cdot F_3^2 + t_4 \cdot F_4^2}{t_1 + t_2 + t_3 + t_4}}$$

Example in case of trapezoidal profile (rotary):

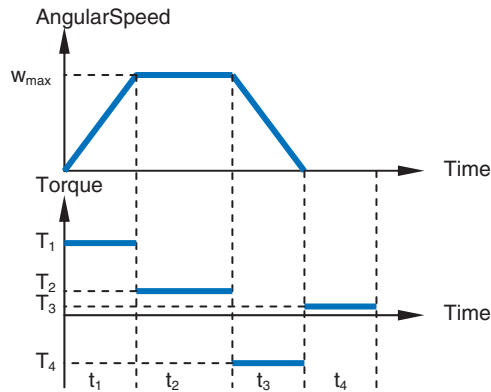

1. Angular acceleration

$$\alpha = \frac{\omega_{max}}{t_1}$$

$$\phi_1 = \frac{1}{2} \cdot \omega_{max} \cdot t_1$$

$$T_{\alpha} = J \cdot \alpha$$

$$T_{1_Total} = T_{\alpha} + T_{\mu} + T_{ext}$$

2. Constant speed

$$\alpha = 0$$

$$\phi_2 = \omega_{max} \cdot t_2$$

$$T_{2_Total} = T_{\mu} + T_{ext}$$

3. Deceleration

$$\gamma = \frac{\omega_{max}}{t_3}$$

$$\phi_3 = \frac{1}{2} \cdot \omega_{max} \cdot t_3$$

$$T_{\gamma} = J \cdot \gamma$$

$$T_{3_Total} = T_{\mu} + T_{ext} - T_{\gamma}$$

4. Dwell

$$\phi_4 = 0$$

$$T_{4_Total} = T_{ext}$$

Torque rms:

$$T_{rms} = \sqrt{\frac{t_1 \cdot T_1^2 + t_2 \cdot T_2^2 + t_3 \cdot T_3^2 + t_4 \cdot T_4^2}{t_1 + t_2 + t_3 + t_4}}$$

For linear motors you have just to apply the formulae for linear motors considering the mass of the load plus the mass of the motor. For rotary motors it is necessary to apply some cinematic transformations to have the magnitudes **from the motor side**.

Case of rotary table:

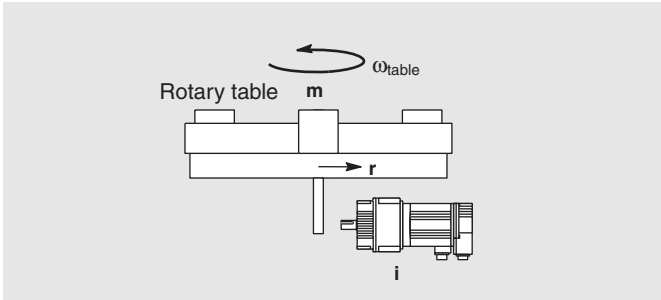

$$J_{total} = J_{motor} + \frac{1}{2} \cdot m \cdot r^2$$

$$\omega_{motor} = \omega_{table} \cdot i$$

$$T_{motor_side} = J_{total} \cdot \alpha_{motor_side}$$

Case of a belt drive with two pulleys:

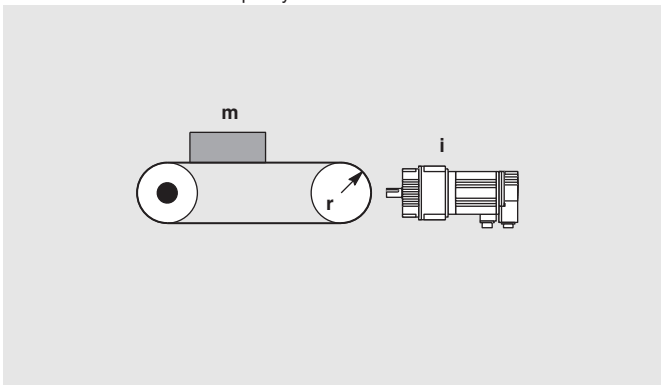

$$J_{total} = J_{motor} + \frac{2 \cdot J_{pulley} + J_{load}}{i^2}$$

$$J_{total} = J_{motor} + \frac{2 \cdot \frac{1}{2} \cdot m_{pulley} \cdot r^2 + m_{load} \cdot r^2}{i^2}$$

$$\alpha_{motor_side} = a \cdot \frac{2\pi}{r} \cdot i$$

$$T_{motor_side} = J_{total} \cdot \alpha_{motor_side} + \frac{m \cdot \mu \cdot g \cdot r}{i}$$

Case of an hanging load:

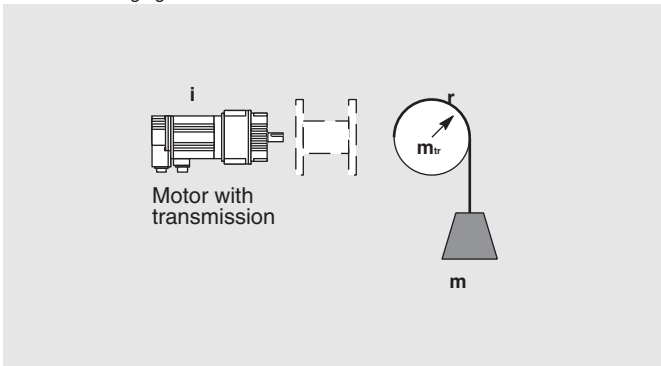

$$J_{total} = J_{motor} + \frac{2 \cdot J_{reel} + J_{load}}{i^2}$$

$$J_{total} = J_{motor} + \frac{\frac{1}{2} \cdot m_{reel} \cdot r^2 + m_{load} \cdot r^2}{i^2}$$

$$\alpha_{motor_side} = a \cdot \frac{2\pi}{r} \cdot i$$

$$T_{motor_side} = J_{total} \cdot \alpha_{motor_side} \pm \frac{m \cdot g \cdot r}{i}$$

Note: The sign (±) depends on the direction of the movement

Case of a ballscrew:

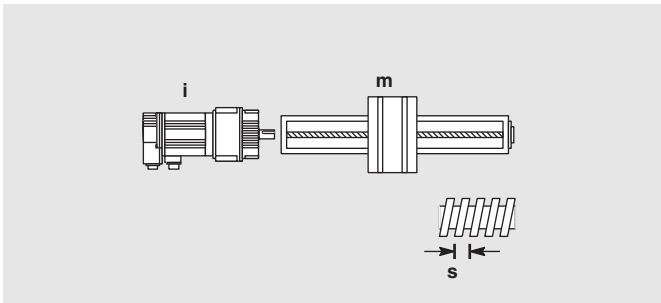

$$J_{total} = J_{motor} + \frac{\left(\frac{s}{2\pi}\right)^2 \cdot m + \frac{1}{2} \cdot m_{screw} \cdot r_{screw}^2}{i^2}$$

$$\alpha_{motor_side} = a \cdot \frac{2\pi}{s} \cdot i$$

$$T_{motor_side} = J_{total} \cdot \alpha_{motor_side} + \frac{m \cdot \mu \cdot g \cdot \frac{s}{2\pi}}{i}$$

Motor selection

Linear motor

The selected linear motor must match the next conditions.

$$v_{\max_motor} > v_{\max_application}$$

$$F_{\max_motor} > \frac{F_{\text{peak_application}}}{\eta}$$

$$F_{\text{rated_motor}} > \frac{F_{\text{rms}}}{\eta}$$

Where: η =Mechanical efficiency

Note 1: To calculate $F_{\text{peak_application}}$ and F_{rms} it is necessary to consider the motor mass. This may deal to do some iteration to get the right motor.

2: At high speed the motor reduces its rated and maximum force. This may be taken into consideration for high speed application.

3: For linear motors it is important to calculate the surface temperature of the motor in addition to the above calculation.

Rotary motor

The selected linear motor must match the next conditions:

$$\omega_{\max_motor} > \omega_{\max_application}$$

$$T_{\max_motor} > \frac{T_{\text{peak_application}}}{\eta}$$

$$T_{\text{rated_motor}} > \frac{T_{\text{rms}}}{\eta}$$

Where: η =Mechanical efficiency

Note 1: To calculate $T_{\text{peak_application}}$ and T_{rms} it is necessary to consider the motor inertia. This may deal to do some iteration to get the right motor.

2: Above rated speed the motor reduces its rated and maximum torque. This may be taken into consideration for high speed application. Refer to the Speed-Torque curves of the motor for details.

Technical documentation

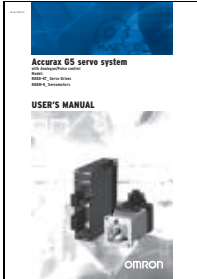

	Product	Title	Cat. No.
Motion controllers	CJ1W-NC Position control units	Datasheet	I04E-EN
	CJ1W-NC Position control units	Operation manual	W397-E1
	CJ1W-NC_4 Position control units	Datasheet	I77E-EN
	CJ1W-NC_4 Position control units	Operation manual	W477-E1
	CJ1W-NC_8 EtherCAT Position control unit	Datasheet	I78E-EN
	CJ1W-NC_8 EtherCAT Position control unit	Operation Manual	W487-E1
	CJ1W-NC2/4/F71 ML2 Position control unit	Datasheet	I09E-EN
	CJ1W-NC2/4/F71 ML2 Position control unit	Operation manual	W426-E1
	Trajexia stand-alone Motion controller	Datasheet	I53E-EN
	Trajexia stand-alone Motion controller	Brochure	Trajexia_EN_INT
	Trajexia stand-alone Motion controller TJ1-MC16/04	Quick Start Guide	I50E-EN
	Trajexia stand-alone Motion controller TJ1-MC16/04	Programming Manual	I51E-EN
	Trajexia stand-alone Motion controller TJ1-MC16/04	Hardware Manual	I52E-EN
	Trajexia stand-alone Motion controller TJ2-MC64	Programming manual	I58E-EN
	Trajexia stand-alone Motion controller TJ2-MC64	Hardware Manual	I57E-EN
	Trajexia Studio	UserManual	I56E-EN
	Trajexia-PLC CJ1W-MC_72 Motion control unit	Datasheet	I54E-EN
	Trajexia-PLC CJ1W-MCH72 Motion control unit	Operation manual	I55E-EN
	Trajexia-PLC CJ1W-MCH72 Motion control unit	Brochure	BRO_Trajexia_EN_INT
	Servo systems	Accurax G5 Analog/pulse Drive programming	Users Manual
Accurax G5 Analog/pulse for rotary motor		User Manual	I571-E2
Accurax G5 Analog/pulse Linear drive		Users Manual	I163E-EN
Accurax G5 EtherCAT Linear Drive		Users Manual	I164E-EN
Accurax G5 EtherCAT Rotary motor		Users Manual	I576-E1
Accurax G5 Linear drive Analog/pulse & EtherCAT		Datasheet	I165E-EN
Accurax G5 ML2 Servo system		User Manual	I572-E2
Accurax G5 Rotary motor		Datasheet	I100E-EN
Accurax G5 Servo drive for rotary motor		Datasheet	I101E-EN
Accurax G5 Servo system for rotary motor		Brochure	CD_EN-__+Accurax-G5+Brochure
Accurax Linear motor		Datasheet	I160E-EN
Accurax Linear motor axis		Datasheet	I161E-EN
G Series Analog/pulse Servo system		Users Manual	I562-E1
G-Series ML2 Servo system		User Manual	I566-E1
G-Series Servo drive		Datasheet	I108E-EN
G-Series Servo motor		Datasheet	I107E-EN
G-Series Servo system		Brochure	KPP_G-Series_EN_INT
SmartStep 2 Servo drive		Datasheet	I106E-EN
SmartStep 2 Servo system		User Manual	I561-E1
SmartStep 2 Servo system		Brochure	KPP_SmartStep2_EN_INT
Frequency inverters	JX Inverter	Quick Start Guide	I128E-EN
	JX Inverter	Brochure	KPP_JX_EN_INT
	JX Inverter	Datasheet	I110E-EN
	JX Inverter	User Manual	I558-E2
	LX Inverter	Datasheet	I119E-EN
	LX Inverter	Quick Start Guide	I131E-EN
	MX2 CompoNet	Operation Manual	I114E-EN
	MX2 DeviceNet	Operation Manual	I112E-EN
	MX2 Inverter	Quick Start Guide	I129E-EN
	MX2 Inverter	Brochure	KPP_MX2_EN_INT
	MX2 Inverter	Datasheet	I113E-EN
	MX2 Inverter	User Manual	I570-E2
	MX2 PROFIBUS	Operation Manual	I111E-EN
	RX Inverter	Quick Start Guide	I130E-EN
	RX Inverter	Brochure	KPP_RX_EN_INT
	RX Inverter	Datasheet	I116E-EN
	RX Inverter	User Manual	I560-E2
	SX Inverter	Datasheet	I124E-EN
	SX Inverter	Brochure	CD_EN-__+SX+Brochure
	SX Inverter	Datasheet	I125E-EN
SX-F Inverter	User Manual	I126E-EN	
SX-V Inverter	User Manual	I127E-EN	

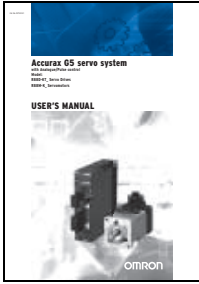

	Product	Title	Cat. No.
Industrial robots	SCARA robots	Brochure	CD_EN-+_Robots+Brochure
	X series, SCARA robots	Datasheet	I135E-EN
	X series, SCARA robots	User Manual	I145E-EN
	XC series, SCARA robots	Datasheet	I133E-EN
	XC series, SCARA robots	User Manual	I144E-EN
	XG series, SCARA robots	Datasheet	I136E-EN
	XG series, SCARA robots	User Manual	I141E-EN
	XP series, SCARA robots	Datasheet	I134E-EN
	XP series, SCARA robots	User Manual	I143E-EN
	XS series, SCARA robots	Datasheet	I132E-EN
	XS series, SCARA robots	User Manual	I142E-EN
	XS, XC, XP, X, XG, SCARA robots (combined datasheet)	Datasheet	I137-EN
	YRC series, SCARA robots, CE-marking (Certificate, Installation, Wiring, Safety)	Support Manual	I154E-EN
	YRC series, SCARA robots, DeviceNet slave board	Reference Manual	I152E-EN
	YRC series, SCARA robots, DeviceNet slave board	User Manual	I153E-EN
	YRC series, SCARA robots, Ethernet (Protocol, TCP/IP, Telnet, Communication, Remote, Send/Receive data)	User Manual	I151E-EN
	YRC series, SCARA robots, Integrated vision, iVY (Conveyor tracking, Encoder, Synchronization, Camera)	User Manual	I147E-EN
	YRC series, SCARA robots, PROFIBUS, (Slave board)	Reference Manual	I149E-EN
	YRC series, SCARA robots, PROFIBUS, (Slave board)	User Manual	I150E-EN
	YRC series, SCARA robots, SCARA Studio, Programming software (Setup, Configuration)	User Manual	I148E-EN
	YRC series, SCARA robots, Tiny series (R6YXG120, R6YXG150, R6YXG180, R6YXG220)	User Manual	I146E-EN
YRC, SCARA robots (Robot programming, JIS, Basic, Commands, Controller)	Programming Manual	I139E-EN	
YRC, SCARA robots (Robot usage, Installation, Controller, Wiring, End effector, Specifications)	User Manual	I140E-EN	
Scalable Machine Automation	Brochure	CD_EN-+_SMA+Brochure	
EtherCAT-Solutions	Brochure	CD_EN-+_EtherCAT+Brochure	

Index

A

Accurax G5 linear drive	83
Accurax G5 servo drive	59
Accurax G5 servo motors	129
Accurax linear motor	157
Accurax linear motor axis	173

C

CJ1W-MCH72	39
CJ1W-NC□□3	47
CJ1W-NC□□4	51
CJ1W-NC□8□ - NC EtherCAT	35
CJ1W-NC271	43
CJ1W-NC471	43
CJ1W-NCF71	43

G

G-Series servo drive	103
G-Series servo motors	147

J

JX	239
----	-----

L

LETLA-□-F□	157
LX	209

M

MX2	225
-----	-----

N

NC MECHATROLINK-II	43
--------------------	----

R

R6YXC1000	310
R6YXC180	301
R6YXC220	302
R6YXC500	306
R6YXC600	307
R6YXC700	308
R6YXC800	309

R6YXCH250	303
R6YXCH350	304
R6YXCH400	305
R6YXG1000	296
R6YXG120	286
R6YXG150	287
R6YXG180	288
R6YXG220	289
R6YXG500	290
R6YXG600	291
R6YXG700	293
R6YXG800	294
R6YXG900	295
R6YXGH600	292
R6YXH250	297
R6YXH350	298
R6YXH400	299
R6YXP1000	318
R6YXP250	311
R6YXP350	312
R6YXP400	313
R6YXP500	314
R6YXP600	315
R6YXP700	316
R6YXP800	317
R6YXS1000	325
R6YXS500	321
R6YXS600	322
R6YXS700	323
R6YXS800	324
R6YXSH300	319
R6YXSH400	320
R6YXX1200	300
R7D-BP□	117
R88D-GN□	103
R88D-GP08H	117
R88D-GT□	103
R88D-KN□□□-ECT	59
R88D-KN□□□-ECT-L	83
R88D-KN□□□-L	83
R88D-KN□□□-ML2	59
R88D-KT□	59
R88L-EA-AF-□	173
R88L-EC-FW/GW-□	157
R88M-G□	147
R88M-K□	129
RX	191

S

SCARA robot series	277
SmartStep 2 servo drive	117
SX (400 V)	249
SX (690 V)	261

T

Trajexia stand-alone	25
Trajexia-PLC CJ1W-MCH72	39

Y

YRC	278
-----------	-----

OMRON EUROPE B.V. Wegalaan 67-69, NL-2132 JD, Hoofddorp, The Netherlands. Tel: +31 (0) 23 568 13 00 Fax: +31 (0) 23 568 13 88 www.industrial.omron.eu

Austria

Tel: +43 (0) 2236 377 800
www.industrial.omron.at

Belgium

Tel: +32 (0) 2 466 24 80
www.industrial.omron.be

Czech Republic

Tel: +420 234 602 602
www.industrial.omron.cz

Denmark

Tel: +45 43 44 00 11
www.industrial.omron.dk

Finland

Tel: +358 (0) 207 464 200
www.industrial.omron.fi

France

Tel: +33 (0) 1 56 63 70 00
www.industrial.omron.fr

Germany

Tel: +49 (0) 2173 680 00
www.industrial.omron.de

Hungary

Tel: +36 1 399 30 50
www.industrial.omron.hu

Italy

Tel: +39 02 326 81
www.industrial.omron.it

Netherlands

Tel: +31 (0) 23 568 11 00
www.industrial.omron.nl

Norway

Tel: +47 (0) 22 65 75 00
www.industrial.omron.no

Poland

Tel: +48 (0) 22 645 78 60
www.industrial.omron.pl

Portugal

Tel: +351 21 942 94 00
www.industrial.omron.pt

Russia

Tel: +7 495 648 94 50
www.industrial.omron.ru

South Africa

Tel: +27 (0)11 608 3041
www.industrial.omron.co.za

Spain

Tel: +34 913 777 900
www.industrial.omron.es

Sweden

Tel: +46 (0) 8 632 35 00
www.industrial.omron.se

Switzerland

Tel: +41 (0) 41 748 13 13
www.industrial.omron.ch

Turkey

Tel: +90 212 467 30 00
www.industrial.omron.com.tr

United Kingdom

Tel: +44 (0) 870 752 08 61
www.industrial.omron.co.uk

More Omron representatives
www.industrial.omron.eu

Authorised Distributor:

ADVANCED INDUSTRIAL AUTOMATION**Automation Systems**

- Programmable logic controllers (PLC) • Human machine interfaces (HMI)
- Remote I/O • Industrial PC's • Software

Motion & Drives

- Motion controllers • Servo systems • Inverters • Robots

Control & Switching Components

- Temperature controllers • Power supplies • Timers • Counters • Programmable relays
- Digital panel indicators • Electromechanical relays • Monitoring products
- Solid-state relays • Limit switches • Pushbutton switches • Low voltage switch gear

Sensing & Safety

- Photoelectric sensors • Inductive sensors • Capacitive & pressure sensors
- Cable connectors • Displacement & width-measuring sensors • Vision systems
- Safety networks • Safety sensors • Safety units/relay units
- Safety door/guard lock switches