

SYSMAC
CJ1W-NC281/NC481/NC881/NCF81
CJ1W-NC482/NC882/NCF82

Position Control Units

OPERATION MANUAL

OMRON

Introduction

Thank you for purchasing a SYSMAC CJ1W-NC281, CJ1W-NC481, CJ1W-NC881, CJ1W-NCF81, CJ1W-NC482, CJ1W-NC882 or CJ1W-NCF82 Position Control Unit (PCU). The CJ1W-NC281, CJ1W-NC481, CJ1W-NC881, CJ1W-NCF81, CJ1W-NC482, CJ1W-NC882 and CJ1W-NCF82 Position Control Units (PCUs) are CPU Bus Units for SYSMAC CJ-series Programmable Controllers (PLCs). This manual contains information required to use these PCUs. Please thoroughly read and understand this manual before you use any of these PCUs.

Notice:

OMRON products are manufactured for use according to proper procedures by a qualified operator and only for the purposes described in this manual.

The following conventions are used to indicate and classify precautions in this manual. Always heed the information provided with them. Failure to heed precautions can result in injury to people or damage to property.



DANGER

Indicates an imminently hazardous situation which, if not avoided, will result in death or serious injury. Additionally, there may be severe property damage.



WARNING

Indicates a potentially hazardous situation which, if not avoided, could result in death or serious injury. Additionally, there may be severe property damage.



Caution

Indicates a potentially hazardous situation which, if not avoided, may result in minor or moderate injury, or property damage.

OMRON Product References

All OMRON products are capitalized in this manual. The word “Unit” is also capitalized when it refers to an OMRON product, regardless of whether or not it appears in the proper name of the product. The abbreviation “Ch” which appears in some displays and on some OMRON products, often means “word” and is abbreviated “Wd” in documentation in this sense.

The abbreviation “PLC” means Programmable Controller. “PC” is used, however, in some Programming Device displays to mean Programmable Controller.

Visual Aids

The following headings appear in the left column of the manual to help you locate different types of information.

Note

Indicates information of particular interest for efficient and convenient operation of the product.

1,2,3...

1. Indicates lists of one sort or another, such as procedures, checklists, etc.

Trademarks

- ♦ Windows is a registered trademark of Microsoft Corporation.
- ♦ EtherCAT® is registered trademark and patented technology, licensed by Beckhoff Automation GmbH, Germany.
- ♦ ODVA, CIP, CompoNet, DeviceNet, and EtherNet/IP are trademarks of ODVA.
- ♦ Other system names and product names in this document are the trademarks or registered trademarks of their respective companies.

©OMRON, 2010

All rights reserved. No part of this publication may be reproduced, stored in a retrieval system, or transmitted, in any form, or by any means, mechanical, electronic, photocopying, recording, or otherwise, without the prior written permission of OMRON.

No patent liability is assumed with respect to the use of the information contained herein. Moreover, because OMRON is constantly striving to improve its high-quality products, the information contained in this manual is subject to change without notice. Every precaution has been taken in the preparation of this manual. Nevertheless, OMRON assumes no responsibility for errors or omissions. Neither is any liability assumed for damages resulting from the use of the information contained in this publication.

Terms and Conditions Agreement

Warranty, Limitations of Liability

Warranties

Exclusive Warranty

Omron's exclusive warranty is that the Products will be free from defects in materials and workmanship for a period of twelve months from the date of sale by Omron (or such other period expressed in writing by Omron). Omron disclaims all other warranties, express or implied.

Limitations

OMRON MAKES NO WARRANTY OR REPRESENTATION, EXPRESS OR IMPLIED, ABOUT NON-INFRINGEMENT, MERCHANTABILITY OR FITNESS FOR A PARTICULAR PURPOSE OF THE PRODUCTS. BUYER ACKNOWLEDGES THAT IT ALONE HAS DETERMINED THAT THE PRODUCTS WILL SUITABLY MEET THE REQUIREMENTS OF THEIR INTENDED USE.

Omron further disclaims all warranties and responsibility of any type for claims or expenses based on infringement by the Products or otherwise of any intellectual property right.

Buyer Remedy

Omron's sole obligation hereunder shall be, at Omron's election, to (i) replace (in the form originally shipped with Buyer responsible for labor charges for removal or replacement thereof) the non-complying Product, (ii) repair the non-complying Product, or (iii) repay or credit Buyer an amount equal to the purchase price of the non-complying Product; provided that in no event shall Omron be responsible for warranty, repair, indemnity or any other claims or expenses regarding the Products unless Omron's analysis confirms that the Products were properly handled, stored, installed and maintained and not subject to contamination, abuse, misuse or inappropriate modification. Return of any Products by Buyer must be approved in writing by Omron before shipment. Omron Companies shall not be liable for the suitability or unsuitability or the results from the use of Products in combination with any electrical or electronic components, circuits, system assemblies or any other materials or substances or environments. Any advice, recommendations or information given orally or in writing, are not to be construed as an amendment or addition to the above warranty.

See <http://www.omron.com/global/> or contact your Omron representative for published information.

Limitation on Liability; Etc

OMRON COMPANIES SHALL NOT BE LIABLE FOR SPECIAL, INDIRECT, INCIDENTAL, OR CONSEQUENTIAL DAMAGES, LOSS OF PROFITS OR PRODUCTION OR COMMERCIAL LOSS IN ANY WAY CONNECTED WITH THE PRODUCTS, WHETHER SUCH CLAIM IS BASED IN CONTRACT, WARRANTY, NEGLIGENCE OR STRICT LIABILITY.

Further, in no event shall liability of Omron Companies exceed the individual price of the Product on which liability is asserted.

Application Considerations

Suitability of Use

Omron Companies shall not be responsible for conformity with any standards, codes or regulations which apply to the combination of the Product in the Buyer's application or use of the Product. At Buyer's request, Omron will provide applicable third party certification documents identifying ratings and limitations of use which apply to the Product. This information by itself is not sufficient for a complete determination of the suitability of the Product in combination with the end product, machine, system, or other application or use. Buyer shall be solely responsible for determining appropriateness of the particular Product with respect to Buyer's application, product or system. Buyer shall take application responsibility in all cases.

NEVER USE THE PRODUCT FOR AN APPLICATION INVOLVING SERIOUS RISK TO LIFE OR PROPERTY WITHOUT ENSURING THAT THE SYSTEM AS A WHOLE HAS BEEN DESIGNED TO ADDRESS THE RISKS, AND THAT THE OMRON PRODUCT(S) IS PROPERLY RATED AND INSTALLED FOR THE INTENDED USE WITHIN THE OVERALL EQUIPMENT OR SYSTEM.

Programmable Products

Omron Companies shall not be responsible for the user's programming of a programmable Product, or any consequence thereof.

Disclaimers

Performance Data

Data presented in Omron Company websites, catalogs and other materials is provided as a guide for the user in determining suitability and does not constitute a warranty. It may represent the result of Omron's test conditions, and the user must correlate it to actual application requirements. Actual performance is subject to the Omron's Warranty and Limitations of Liability.

Change in Specifications

Product specifications and accessories may be changed at any time based on improvements and other reasons. It is our practice to change part numbers when published ratings or features are changed, or when significant construction changes are made. However, some specifications of the Product may be changed without any notice. When in doubt, special part numbers may be assigned to fix or establish key specifications for your application. Please consult with your Omron's representative at any time to confirm actual specifications of purchased Product.

Errors and Omissions

Information presented by Omron Companies has been checked and is believed to be accurate; however, no responsibility is assumed for clerical, typographical or proofreading errors or omissions.

Precautions

This section provides general precautions for using the Position Control Units and related devices. The information contained in this section is important for the safe and reliable application of the Position Control Units. You must read this section and understand the information contained before attempting to set up or operate a Position Control Unit.

Intended Audience

This manual is intended for the following personnel, who must also have knowledge of electrical systems (an electrical engineer or the equivalent).

- Personnel in charge of installing FA systems.
- Personnel in charge of designing FA systems.
- Personnel in charge of managing FA systems and facilities.

General Precautions

The user must operate the product according to the performance specifications described in the Operation Manuals.

Before using the product under conditions which are not described in the manual or applying the product to nuclear control systems, railroad systems, aviation systems, vehicles, combustion systems, medical equipment, amusement machines, safety equipment, and other systems, machines, and equipment that may have a serious influence on lives and property if used improperly, consult your OMRON representative.

Make sure that the ratings and performance characteristics of the product are sufficient for the systems, machines, and equipment, and be sure to provide the systems, machines, and equipment with double safety mechanisms.

This manual provides information for using the Position Control Unit. Be sure to read this manual before attempting to use the Unit and keep this manual close at hand for reference during operation.



WARNING

It is extremely important that Position Control Units and related devices be used for the specified purpose and under the specified conditions, especially in applications that can directly or indirectly affect human life. You must consult with your OMRON representative before applying Position Control Units and related devices to the above mentioned applications.

Safety Precautions



WARNING

Never attempt to disassemble any Units while power is being supplied. Doing so may result in serious electric shock.



WARNING

Never touch any of the terminals while power is being supplied. Doing so may result in serious electric shock.



WARNING

Provide safety measures in external circuits (i.e., not in the Programmable Controller or Position Control Unit) to ensure safety in the system if an abnormality occurs due to malfunction of the PLC, malfunction of the PCU (Position Control Unit), or external factors affecting the operation of the PLC or PCU.

Not providing sufficient safety measures may result in serious accidents.

- Emergency stop circuits, interlock circuits, limit circuits, and similar safety measures must be provided in external control circuits.
- The PLC will turn OFF all outputs when its self-diagnosis function detects any error or when a severe failure alarm (FALS) instruction is executed. Unexpected operation, however, may still occur for errors in the I/O control section, errors in I/O memory, and other errors that cannot be detected by the self-diagnosis function.
As a countermeasure for all such errors, external safety measures must be provided to ensure safety in the system.
- The PLC or PCU outputs may remain ON or OFF due to deposits on or burning of the output relays, or destruction of the output transistors. As a countermeasure for such problems, external safety measures must be provided to ensure safety in the system.
- Provide measures in the computer system and programming to ensure safety in the overall system even if errors or malfunctions occur in data link communications or remote I/O communications.



WARNING

Confirm safety before transferring data files stored in the file memory (i.e., in a Memory Card or EM file memory) to the I/O Area (CIO Area) of the CPU Unit using Support Software. Otherwise, the devices connected to the Output Unit may malfunction regardless of the operating mode of the CPU Unit.



WARNING

Fail-safe measures must be taken by the customer to ensure safety in the event of incorrect, missing, or abnormal signals caused by broken signal lines, momentary power interruptions, or other causes. Serious accidents may occur due to abnormal operation if proper measures are not taken.



WARNING

Make sure that the voltages and currents input to Units are within the specified ranges. Inputting voltages or currents that are outside of the specified ranges may cause accidents or fire.



Caution

Execute online edit only after confirming that no adverse effects will be caused by extending the cycle time. Otherwise, the input signals may not be readable.



Caution

Confirm safety at the destination node before transferring a program or parameters (including the PLC Setup and I/O tables) to another node or changing the contents of the I/O memory area. The device or machine at the destination may operate in an unexpected manner.



Caution

Always save the data or parameters to flash memory after transferring parameters or data to the PCU. If the data or parameters are not saved, the previous condition will be restored when the power is turned ON again, possibly causing incorrect machine operation.



Caution

Carefully check the axis number before operating the PCU from Support Software.

Operating Environment Precautions

**Caution**

Do not operate the control system in the following locations:

- Locations subject to direct sunlight.
- Locations subject to temperatures or humidity outside the range specified in the specifications.
- Locations subject to condensation as the result of severe changes in temperature.
- Locations subject to corrosive or flammable gases.
- Locations subject to dust (especially iron dust) or salts.
- Locations subject to exposure to water, oil, or chemicals.
- Locations subject to shock or vibration.

**Caution**

Take appropriate and sufficient countermeasures when installing systems in the following locations:

- Locations subject to static electricity or other forms of noise.
- Locations subject to strong electromagnetic fields.
- Locations subject to possible exposure to radioactivity.
- Locations close to power supplies.

Application Precautions

Observe the following precautions when using the PCU or the PLC.

**WARNING**

Failure to abide by the following precautions could lead to serious or possibly fatal injury. Always heed these precautions.

- Always turn OFF the power supply to the PLC before attempting any of the following. Not turning OFF the power supply may result in malfunction or electric shock.
 - Mounting or dismounting Power Supply Units, I/O Units, CPU Units, Memory Cassettes, or any other Units.
 - Assembling the Units.
 - Setting DIP switches or rotary switches.
 - Connecting cables or wiring the system.
 - Connecting or disconnecting the connectors.

**Caution**

Failure to abide by the following precautions may lead to faulty operation of the PLC, the PCU, or the system, or could damage the PLC or PCU. Always heed these precautions.

- Install external breakers and take other safety measures against short-circuiting in external wiring. Insufficient safety measures against short-circuiting may result in burning.
- Lock the sliders securely until the click into place when connecting the Power Supply Unit, CPU Unit, I/O Units, Special I/O Units, or CPU Bus Units. Functions may not work correctly if the sliders are not locked properly.
- Always attach the End Cover provided with the CPU Unit to the Unit on the right end of the PLC. The CJ-series PLC will not operate properly if the End Cover is not attached.
- Always use the power supply voltages specified in the Operation Manuals. An incorrect voltage may result in malfunction or burning.
- Take appropriate measures to ensure that the specified power with the rated voltage and frequency is supplied in places where the power supply is unstable. An incorrect power supply may result in malfunction.

Precautions

- Use crimp terminals for wiring. Do not connect bare stranded wires directly to terminals. Connection of bare stranded wires may result in burning.
- Leave the label attached to the Unit when wiring. Removing the label may result in malfunction if foreign matter enters the Unit.
- Remove the label after the completion of wiring to ensure proper heat dissipation. Leaving the label attached may result in malfunction.
- Do not apply voltages or connect loads to the Output Units in excess of the maximum switching capacity. Excess voltage or loads may result in burning.
- Check the user program for proper execution before actually running it on the Unit. Not checking the program may result in an unexpected operation.
- Be sure that the terminal blocks, Memory Units, expansion cables, and other items with locking devices are properly locked into place. Improper locking may result in malfunction.
- Double-check all wiring and switch settings before turning ON the power supply. Incorrect wiring may result in burning.
- Confirm that no adverse effect will occur in the system before attempting any of the following. Not doing so may result in an unexpected operation.
 - Changing the operating mode of the PLC (including the operating mode at power up).
 - Force-setting/force-resetting any bit in memory.
 - Changing the present value of any word or any set value in memory.
- Resume operation only after transferring to the new CPU Unit the contents of the DM Area, HR Area, and other data required for resuming operation. Not doing so may result in an unexpected operation.
- Do not pull on the cables or bend the cables beyond their natural limit. Doing either of these may break the cables.
- Do not place objects on top of the cables or other wiring lines. Doing so may break the cables.
- Perform wiring according to specified procedures.
- Use the cables specified in this manual.
- Before touching a Unit, be sure to first touch a grounded metallic object in order to discharge any static build-up. Not doing so may result in malfunction or damage.
- Sufficiently confirm that set parameters and data operate properly before using them for actual operation.
- The equipment may operate unexpectedly if inappropriate parameters or data is set.
- Never turn OFF the power supply to the PLC while data is being transferred.
- If there is interference with communications, output status will depend on the products that are being used. When using products with outputs, confirm the operation that will occur when there is interference with communications and implement safety measures.
- When using data link communications, check the PLC error information given in the status flags to make sure that no error has occurred in the source PLC. Create a program that uses the received data only if there is no error. If there is an error, the PLC may be sending incorrect data.
- Do not exceed the specified ranges for the communications distance and number of nodes.

Conformance to EC Directives

Applicable Directives

- EMC Directives

Concepts

EMC Directives

OMRON devices that comply with EC Directives also conform to the related EMC standards so that they can be more easily built into other devices or machines. The actual products have been checked for conformity to EMC standards (see the following note). Whether the products conform to the standards in the system used by the customer, however, must be checked by the customer.

EMC-related performance of the OMRON devices that comply with EC Directives will vary depending on the configuration, wiring, and other conditions of the equipment or control panel in which the OMRON devices are installed.

The customer must, therefore, perform final checks to confirm that devices and the overall machine conform to EMC standards.

Note

Applicable EMC (Electromagnetic Compatibility) standards are as follows:

EMS (Electromagnetic Susceptibility): EN61000-6-2

EMI (Electromagnetic Interference): EN61000-6-4

(Radiated emission: 10-m regulations)

Conformance to EC Directives

The PCUs comply with EC Directives. To ensure that the machine or device in which a PCU is used complies with EC Directives, the PCU must be installed as follows:

1,2,3...

1. The PCU must be installed within a control panel.
2. Reinforced insulation or double insulation must be used for the DC power supplies used for the communications and I/O power supplies.
3. PCUs complying with EC Directives also conform to the Common Emission Standard (EN61000-6-4). With regard to the radiated emission (10-m regulations), countermeasures will vary depending on the devices connected to the control panel, wiring, the configuration of the system, and other conditions. The customer must, therefore, perform final checks to confirm that devices and the overall machine conform to EC Directives.

Installation within Control Panel

Unnecessary clearance in cable inlet or outlet ports, operation panel mounting holes, or in the control panel door may cause electromagnetic wave leakage or interference. In this case, the product may fail to meet EC Directives. In order to prevent such interference, fill clearances in the control panel with conductive packing. (In places where conductive packing comes in contact with the control panel, ensure electrical conductivity by removing the paint coating or masking these parts when painting.)

Items to Check When Unpacking

Check the items below after unpacking:

- ♦ Is this the correct model you ordered?
- ♦ Do you find any damage which was sustained during transportation?

Accessory of This Product

1. Safety Precautions Document × 1 copy

- ♦ Connectors and mounting screws are not supplied and must be provided by the customer.
- ♦ If you find any missing items or any problems, such as damage to the PCU, contact the OMRON dealer or sales office from which you purchased your product.

How to Read the Model Number

PCU Model Numbers

You can identify the number of axes and output pattern from the model number.

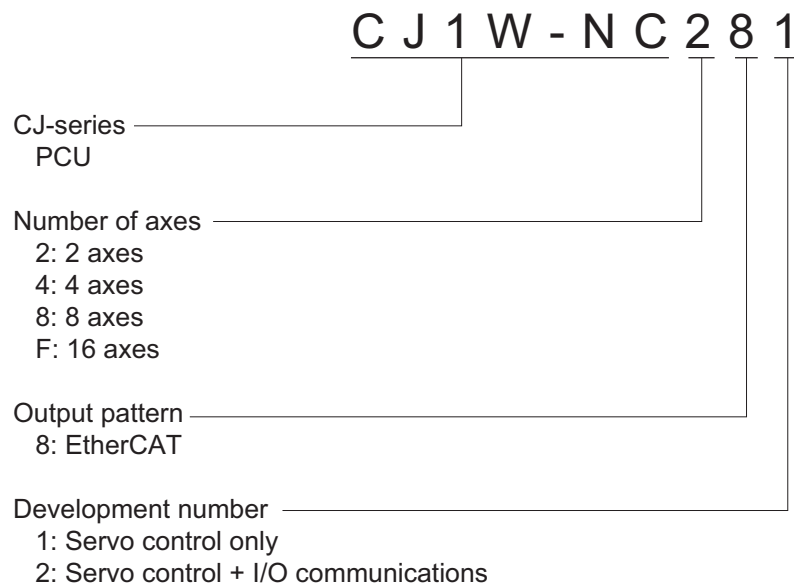

Revision History

A manual revision code appears as a suffix to the catalog number on the front cover of the manual.

Cat. No.	W487-E1-05
-----------------	-------------------

↑ Revision code

Revision code	Date	Revised content
01	March 2010	Original production
02	July 2010	Revision for the addition of models and an upgrade to unit version 1.10.
03	July 2010	Corrected mistakes.
04	April 2011	Revision for the addition of models and an upgrade to unit version 1.30.

Revision History

Revision code	Date	Revised content
05	August 2014	<p>Globally: Added registered trademark symbol for EtherCAT. Page 1: Updated trademark information. Pages 3 and 4: Replaced information. Page 12: Updated model information for W393 and W446. Page 1-30: Added column to table and note after table. Pages 1-31 and 1-32: Added column and row to table. Page 2-2: Changed callout for ESI files. Page 2-17: Added information to footnote 2. Page 2-25: Added information toward the bottom of the page. Page 4-6: Changed item 1. Pages 5-6, 6-92, and 7-4: Changed "1000" to "10000" for B+6 and B+7. Page 5-19: Changed "4294967295" to "2147483647." Page 5-49: Added note after figure, reference to note in figure, and information toward beginning of <i>Outline of Operation</i>. Page 5-54: Changed last precaution at top of page. Page 6-28: Added information to bottom of page. Page 6-35: Added precaution. Page 6-36: Added reference information. Pages 6-63 and 8-83: Added information to bottom of page. Page 6-156: Added information to end of <i>Positioning Completed Input Monitor Valid</i>. Page 8-32: Changed description of function of command data in bottom table. Page 8-40: Added information in middle of page. Page 8-45: Changed "one control cycle or longer" to "two control cycles or longer." Page 8-53: Added information after the table. Page 8-85: Added information after second paragraph. Page 9-4: Changed address ranges. Page 9-11: Added row toward bottom of table. Page 10-25: Revised procedure and reference information, and added precaution. Page 10-26: Replaced figure. Page 11-1: Corrected version at top of page. Pages 11-25 and 11-31: Changed third paragraph on page. Page 11-29: Change torque data list. Page 11-35: Replaced precaution with other information. Page 13-40: Added paragraph before table. Page 14-4: Added introduction to and changed step 2 of bottom procedure.</p>

Related Manuals

Manuals related to using a Position Control Unit are listed in the following table. Use these manuals for reference.

Manual	Cat. No.	Model	Application	Description
CJ-series Position Control Unit Operation Manual (this manual)	W487	CJ1W-NC281 CJ1W-NC481 CJ1W-NC881 CJ1W-NCF81 CJ1W-NC482 CJ1W-NC882 CJ1W-NCF82	Information on CJ1W-NC281/NC481/NC881/NCF81/NC482/NC882/NCF82 PCUs	Describes the setting and application procedures for the PCUs.
CJ-series CJ2 CPU Unit Software User's Manual	W473	CJ2H-CPU6□-EIP CJ2H-CPU6□ CJ2M-CPU□□	Software specifications for CJ2 CPU Units	Describes the following for CJ2 CPU Units: <ul style="list-style-type: none"> • CPU Unit operation • Internal memory • Programming • Settings • Functions built into the CPU Unit Also refer to the <i>Hardware User's Manual</i> (W472).
CJ-series CJ2 CPU Unit Hardware User's Manual	W472	CJ2H-CPU6□-EIP CJ2H-CPU6□ CJ2M-CPU□□	Hardware specifications for CJ2 CPU Units	Describes the following for CJ2 CPU Units: <ul style="list-style-type: none"> • Overview and features • Basic system configuration • Part nomenclature and functions • Mounting and setting procedure • Troubleshooting Also refer to the <i>Software User's Manual</i> (W473).
SYSMAC CJ/NSJ Series Programmable Controllers Operation Manual	W393	CJ1H-CPU□□H-R, CJ1G/H-CPU□□H, CJ1G-CPU□□P, CJ1G-CPU□□, CJ1M-CPU□□	Overview, designing, installation, maintenance, and other basic information on the CJ/NSJ-series PLCs	Describes the following for PLCs with CJ1 CPU Units: <ul style="list-style-type: none"> • Overview and features • System configuration design • Installation and wiring • I/O memory allocation • Troubleshooting Also refer to the <i>Programming Manual</i> (W394).
SYSMAC CS/CJ/NSJ Series Programmable Controllers Programming Manual	W394	CS1G/H-CPU□□-EV1, CS1G/H-CPU□□H, CS1D-CPU□□H, CS1D-CPU□□S, CJ1H-CPU□□H-R, CJ1G-CPU□□, CJ1G/H-CPU□□H, CJ1G-CPU□□P, CJ1M-CPU□□, NSJ□-□□□□(B)-G5D, NSJ□-□□□□(B)-M3D	Information on the functions of CS/CJ/NSJ-series PLCs	Describes the following for PLCs with CS/CJ-series CPU Units: <ul style="list-style-type: none"> • Programming • Using tasks • Using file memory • Using other functions Also refer to the <i>Operation Manual</i> (W393).
CX-Programmer Operation Manual	W446	CXONE-AL□□C-V4/ AL□□D-V4	Support Software for Windows computers CX-Programmer operating procedure	Describes operating procedures for the CX-Programmer.
OMNUC G5-series AC Servomotors/ Servo Drives with Built-in EtherCAT® Communications User's Manual	I573	R88M-K□ R88D0KN□-ECT-R	Settings for OMNUC G5-series Servo Drives	Describes the setting and adjustment procedures for OMNUC G5-series Servo Drives.

Structure of This Document

This manual consists of the following sections. Use this table as a guide to find and read the required sections.

		Outline
Section 1	Product Overview	This section describes the features and operating procedures for the Position Control Units (PCUs) and also provides an overview of EtherCAT, information on unit versions, and other basic information on the PCUs.
Section 2	EtherCAT Communications	This section provides an introduction to EtherCAT and describes its communications functions.
Section 3	Installation and Wiring	This section describes the names and functions, installation method, wiring method, and other hardware information.
Section 4	Manual Operation	This section describes manual operation, such as jogging and inching, when the PCU is used in combination with an OMNUC G5-series Servo Drive.
Section 5	Defining the Origin	This section describes how to determine the origin, such as the origin search procedure as well as origin returns, present position presets and absolute encoder settings when the PCU is used in combination with an OMNUC G5-series Servo Drive.
Section 6	Setting Data	This section describes the overall data configuration, EtherCAT data settings, common parameters, axis parameters, and other data that is used for the PCU.
Section 7	Direct Operation	This section describes the procedure to perform direct operation, including setting the operation data and operation methods.
Section 8	Memory Operation	This section describes the procedure to perform memory operation, setting of memory data, and operating methods, etc.
Section 9	Transferring and Saving Data	This section describes the data transfer method from the CPU Unit of the PLC and the data transfer method with the CX-Programmer.
Section 10	Operating Functions	This section describes the auxiliary operation functions, such as teaching, interrupt feeding, and overrides.
Section 11	Programming Examples	This section contains program examples to perform linear interpolation control, circular interpolation control, origin searches, etc.
Section 12	Troubleshooting	This section describes the items to check when problems occur, error diagnosis and countermeasures for alarm indications, and error diagnosis and countermeasures for operating conditions.
Section 13	Maintenance and Inspection	This section describes periodic maintenance and inspection.
Appendix		The appendix contains performance tables and describes how these PCUs are different from previous models.

Table Of Contents

Introduction	1
Terms and Conditions Agreement	3
Precautions	5
Items to Check When Unpacking	10
Revision History	11
Related Manuals	13
Structure of This Document	14
Section 1 Product Overview	
1-1 Features	1-1
Features	1-2
1-2 System Configuration	1-4
System Configuration Example for the CJ1W-NC882	1-4
1-3 Basic Functions	1-5
Positioning Functions	1-5
Position Control	1-6
Speed Control	1-8
Other Functions	1-9
Remote I/O master function	1-10
1-4 Basic Operating Procedures	1-11
Basic Flow of Operation	1-11
Going Online from the CX-Programmer	1-13
Setting I/O Tables	1-14
Automatic Network Setup	1-16
Setting Parameters	1-17
1-5 Specifications	1-19
General Specifications	1-19
Characteristics	1-20
EtherCAT Communications Specifications	1-26
Functional Specifications	1-27
1-6 Unit Versions	1-29
Confirmation Method	1-29
Unit Versions	1-30
Function Support According to Unit Versions	1-31
Function Support According to OMNUC G5-series Servo Drive Versions	1-32
Function Support According to CPU Unit Versions	1-33
1-7 Applicable Directives	1-34
Conformance to EMC Directive	1-34
Concepts	1-34
1-8 Control System Configuration and Principles	1-35
Control System Configuration	1-35
Setting Principles of Positioning System	1-36
1-9 Support Software	1-37
Functions	1-37
Menu Commands	1-39
Windows and Dialog Boxes	1-41
Operating Procedure	1-45

Table Of Contents

Section 2 EtherCAT Communications

2-1	Introduction to EtherCAT	2-1
	CAN Application Protocol over EtherCAT (CoE)	2-1
	Distributed Clock (DC)	2-2
	EtherCAT Communications Settings	2-2
	EtherCAT Communications Control States	2-3
2-2	EtherCAT Functions	2-4
	Relation between Allocated Areas of Memory	2-5
	Relationship between Axes and Slaves	2-8
	PCU Data Exchange	2-10
	Communications Status	2-11
2-3	Network Configuration	2-15
	EtherCAT Communications Network Configuration	2-15
	Selecting PDO Mappings When Using the PCU in Conjunction with a G5-series Servo Drive	2-17
	Configuration Using the Automatic Network Setup	2-18
	Manual Configuration	2-19

Section 3 Installation and Wiring

3-1	Part Names and Area Allocations	3-1
	Part Names	3-1
	Memory Area Allocation List	3-4
3-2	Installing the PCU	3-5
	System Configuration Precautions	3-5
	PCU Installation Method	3-5
	PCU Handling Precautions	3-6
	Dimensions	3-7
3-3	External I/O Circuits	3-8
	PCU I/O Signals	3-8
3-4	Wiring	3-9
	Wiring EtherCAT Communications	3-9
	Wiring Servo Drive I/O Signals	3-11
3-5	Connection Example for Servo Drives	3-13
	Connection Examples for Servo Drive	3-13
3-6	Wiring Unused Axes	3-14
3-7	Wiring Check with the CX-Programmer	3-15
	Operating Procedure	3-15

Section 4 Manual Operation

4-1	Outline of Manual Operation	4-1
	PCU Operating Modes	4-1
4-2	Jogging	4-3
	Operating Procedure	4-3
	Common Parameter Settings	4-3
	Axis Parameter Settings	4-5
	Transferring Parameters and Restarting	4-7
	Timing Chart	4-9
	Program Example	4-10

Table Of Contents

4-3	Inching	4-11
	Operating Procedure	4-11
	Axis Parameter Settings	4-11
	Timing Chart	4-12
	Program Example	4-13
4-4	Operations with CX-Programmer	4-14
	Opening the Test Run Dialog Box	4-14
	Procedure for Jogging/Inching	4-16
	Procedure for Direct Operation	4-17
Section 5 Defining the Origin		
5-1	Outline of Defining the Origin	5-1
5-2	Origin Search Procedure	5-3
	Common Parameter Settings	5-3
	Axis Parameter Settings	5-14
5-3	Origin Search Operation	5-26
	Origin Search Operations	5-26
	Origin Position Latch	5-40
	Origin Compensation	5-40
	Timing Charts	5-41
5-4	Present Position Preset	5-44
	Outline of Operation	5-44
	Starting Present Position Clear Enable	5-44
	Present Position Preset	5-45
5-5	Origin Searches with CX-Programmer	5-46
	Origin Search Procedure	5-46
5-6	Absolute Encoder Origin Setting	5-49
	Outline of Operation	5-49
	Setting Procedure	5-50
5-7	Origin Return Bit	5-54
	Axis Parameter Settings	5-54
	Timing Chart	5-55
Section 6 Setting Data		
6-1	Overall Structure	6-1
	Parameters and Memory Areas List	6-2
	Relation between Allocated Areas of Memory	6-3
	Setting Data with the CX-Programmer	6-9
6-2	EtherCAT Communications Settings	6-11
	EtherCAT communications settings	6-11
	Setting Parameters	6-14
6-3	Common Parameters	6-15
	Common Parameter Table	6-15
	Operation Memory Area Allocation Settings	6-17
	Flash Memory Automatic Save Setting	6-25
	Input Data Resetting for Communications Error	6-26
	Synchronous Data Settings	6-27
	Absolute Encoder Origin Establishment Timing Setting	6-28

Table Of Contents

6-4	Axis Parameters	6-29
	Axis Parameter Table	6-29
	Axis Type Setting.....	6-32
	I/O Function Settings	6-34
	Acceleration/Deceleration Settings.....	6-36
	Output Settings.....	6-39
	Command Position Unit Setting.....	6-40
	Software Limit Settings	6-46
	Zone Settings	6-48
	Interrupt Feeding Settings	6-50
	Origin Search Settings.....	6-51
	Origin Return Settings	6-55
	Jogging/Inching Settings	6-56
	Feedback Input Settings.....	6-57
	Torque Settings	6-58
	Expanded Monitor Settings	6-59
	Deviation Monitor Function Settings.....	6-61
	Positioning Completed Width Setting	6-63
	Synchronous Data Link Setting	6-64
6-5	Memory Operation Parameters	6-71
	Tasks	6-71
	Memory Operation Parameter Table	6-72
	Configuration Axes	6-72
	Teaching Setting.....	6-73
	Interpolation Axis Stop Method.....	6-73
	Deviation between Axes Monitor Settings	6-74
6-6	Operation Memory Areas	6-75
	Outline of Operation Memory Areas	6-76
	PCU Control Memory Area.....	6-79
	Manual Operation Command Memory Area.....	6-89
	Direct Operation Command Memory Area	6-91
	Axis Status Memory Area	6-100
	Memory Operation Command Memory Area.....	6-114
	Memory Operation Status Memory Area	6-115
	Expanded Monitor Memory Area	6-118
	Remote I/O Output Memory Area.....	6-129
	Remote I/O Input Memory Area.....	6-130
	Remote I/O Communications Status Memory Area.....	6-131
6-7	Memory Operation Data	6-147
	Memory Operation Data List.....	6-147
	Details of Memory Operation Data	6-152
6-8	Memory Operation Condition Data.....	6-163
	Memory Operation Condition Data List	6-163
	Details of Memory Operation Condition Data	6-165
	PCU POSITIONING TRIGGER	6-168
Section 7 Direct Operation		
7-1	Outline of Direct Operation.....	7-1
	Direct Operation Procedure.....	7-1
7-2	Setting Direct Operation Data	7-2
	Bits and Words Used in Direct Operation	7-2

Table Of Contents

7-3	Operations in Direct Operation	7-12
	Starting Direct Operation	7-12
	Operations in Direct Operation	7-13
	Deceleration Stop during Direct Operation	7-13
	Multi-starting Direct Operation	7-13
	Multi-starting Operations	7-14
7-4	Timing Charts	7-16
7-5	Starting High-speed PTP Positioning	7-18
	Starting Procedure for High-speed PTP Positioning	7-18
	High-speed PTP Start Instructions	7-19
	How High-speed PTP Start Instructions Are Processed	7-22
	Axis Status during High-speed PTP Positioning	7-23
7-6	Example of Acceleration/ Deceleration Operation	7-24
	Calculation of Basic Acceleration/Deceleration Time	7-24
	Calculation of Acceleration/Deceleration Time for Multi-starting	7-25
	Acceleration/Deceleration Operation with Short Movement	7-26
	Multi-starting with Fixed Acceleration/Deceleration Time	7-27
7-7	Programming Example	7-30
	Description of Operation	7-30
	Parameter Settings	7-31
	Program Example	7-37
	Programming Examples for Starting High-speed PTP Positioning	7-38
7-8	Monitoring with CX-Programmer	7-39
Section 8 Memory Operation		
8-1	Outline of Memory Operation	8-1
	Configuration Axes for Memory Operation	8-2
	Memory Operation Data	8-4
	Memory Operation Procedure	8-5
8-2	Memory Operation Data Settings	8-6
	Memory Operation Data List	8-6
	Memory Operation Condition Data List	8-10
	Memory Area Words and Bits Used in Memory Operation	8-13
8-3	Memory Operation	8-24
	Starting Memory Operation	8-24
	Command	8-25
	Setting Conditions	8-39
	End Pattern	8-42
	Stopping Memory Operation	8-46
	Stopping on Interpolation Path	8-49
8-4	Linear Interpolation	8-50
	Linear Interpolation Speed	8-51
	Interpolation Acceleration Time and Interpolation Deceleration Time	8-52
8-5	Circular Interpolation	8-53
8-6	Timing Charts	8-55
	Preparations for Operation	8-55
	Timing Chart for Memory Operation	8-56
	Timing of Data Changes	8-59
8-7	Acceleration/Deceleration	8-60
	Calculation of Basic Acceleration/Deceleration Time	8-61
	Calculation of Acceleration/Deceleration Time in Continuous Positioning	8-62

Table Of Contents

8-8	Programming Example.....	8-64
	Programming Example 1	8-64
	Programming Example 2	8-74
8-9	Monitoring with CX-Programmer	8-78
	Monitoring Memory Operation	8-78
8-10	Memory Operation Preview.....	8-79
	Procedure	8-79
	Starting the Memory Operation Preview.....	8-80
	Displaying Graphs for One Axis	8-81
	Displaying Two Interpolated Axes	8-82
	Displaying All Axis	8-83
	Operation Path Replay	8-84
	Supported Commands.....	8-85
	Error Messages	8-86
 Section 9 Transferring and Saving Data		
9-1	Outline of Data Transfer	9-1
	Transfer Methods	9-1
	Saving Data	9-3
	Data Addresses	9-4
	Data Checks	9-28
	Operating Modes and Data Transfer	9-30
9-2	Writing with the Data Transfer Bits.....	9-31
	Writing Procedure	9-31
	Timing Chart	9-34
	Programming Example 1	9-35
	Programming Example 2	9-37
9-3	Reading with Data Transfer Bits.....	9-39
	Reading Procedure.....	9-39
	Timing Chart	9-41
	Programming Example 1	9-42
	Programming Example 2	9-43
9-4	Writing Data with IOWR(223).....	9-45
	Writing Procedure	9-45
	IOWR(223) Instruction Specifications.....	9-46
	Program Example	9-48
9-5	Reading Data with IORD(222).....	9-50
	Reading Procedures.....	9-50
	IORD(222) Instruction Specifications	9-50
	Program Example	9-52
9-6	Data Transfer with CX-Programmer	9-54
	Transfer Procedure.....	9-54
9-7	Saving Data	9-56
	Data To Be Saved	9-56
	Executing a Data Save Operation	9-57
9-8	PCU Setup	9-59
	Outline of Operation	9-59
	PCU Operating Modes	9-60
9-9	Simple Backup	9-61
	Outline of Operation	9-61
	Procedures	9-62

Table Of Contents

Section 10 Operating Functions

10-1	Feedback Position Monitoring.....	10-1
	Outline of Operation	10-1
	Axis Parameter Settings	10-3
	Deviation between Axes Monitor Settings	10-5
10-2	Interrupt feeding.....	10-7
	Outline of Operation	10-7
	Interrupt Feeding in Direct Operation	10-9
	Interrupt Feeding in Memory Operation.....	10-12
10-3	Overrides	10-13
	Outline of Operation	10-13
	Override in Operations Other than Memory Operation.....	10-14
	Overrides in Memory Operation	10-14
	Memory Area Words and Bits That Are Used	10-18
10-4	Torque Limits	10-19
	Normal Torque Limits	10-19
	Automatic Control during Origin Searches	10-19
	Updating Torque Limit Data Directly from an Allocated Memory Area	10-20
	Relationship between Forward/Reverse Torque Limit Command Bits and Torque Limit Values	10-20
	Relationship with Synchronous Feeding Torque Options.....	10-21
	Torque Limit Operation.....	10-22
10-5	Teaching	10-23
	Outline of Operation	10-23
	Teaching Procedure	10-24
	Timing Chart.....	10-24
10-6	Positioning Completion	10-25
	Operating Procedures	10-25
	Operating Method.....	10-26
10-7	Present Position Latch	10-28
	Procedure	10-28
	Timing Chart.....	10-30
10-8	Origin Position Latch.....	10-31
	Operating Procedures for Direct Operation Command Memory Area.....	10-31
	Operating Procedures for Origin Search	10-33

Section 11 Synchronous Data Link

11-1	Outline of Synchronous Data Link	11-1
	About Synchronous Data Link.....	11-1
	Setting Procedure.....	11-2
	Notes on CPU Bus Unit Restart	11-4
	7-Segment Display on PCU Front Face	11-4
11-2	Synchronous Data Link.....	11-5
	Synchronous Data Link Settings	11-5
11-3	Synchronous Unit Stop Function	11-7
	All Synchronous Unit Stop.....	11-7
	Synchronous Group Stop	11-8
11-4	Errors Detected in Synchronous Units.....	11-10
	Synchronous Time Monitoring Timeout.....	11-10
	Synchronous Data Link Reception Error	11-10
	Synchronous Data Link Reception Warning.....	11-10
	Synchronous Control Cycle Setting Error.....	11-11

Table Of Contents

11-5	Synchronous Feeding Position.....	11-12
	Outline of Operation	11-12
	Operations with the Synchronous Feeding Position Command	11-14
	Synchronous Feeding Position Controlled Components	11-16
	Torque Option Function.....	11-22
11-6	Synchronous Feeding Velocity.....	11-25
	Outline of Operation	11-25
	Operations with Synchronous Feeding Velocity Command	11-26
	Torque Option Function.....	11-28
11-7	Synchronous Feeding Torque.....	11-31
	Outline of Operation	11-31
	Operations with the Synchronous Feeding Torque Command.....	11-32
	Velocity Limitation Option Function	11-34

Section 12 Programming Examples

12-1	Outline of Programming Examples.....	12-1
	Devices To Be Used	12-1
	Installation and Wiring	12-2
	Mechanical Configuration	12-2
	Parameter Settings.....	12-2
12-2	Basic Programming Examples	12-4
	EtherCAT Communications Interlock	12-4
	Servo Lock/Servo Unlock	12-5
	Origin Search.....	12-5
12-3	Direct Operation	12-6
	Positioning Using the DM Area.....	12-6
	Speed Control.....	12-9
12-4	Memory Operation.....	12-11
	Repeated Operation	12-11
	Linear Interpolation.....	12-17
	Combination of Linear Interpolation and Circular Interpolation	12-25
	Tool Changer (Shortest Route Rotation Control)	12-31

Section 13 Troubleshooting

13-1	Troubleshooting.....	13-1
	Preliminary Check Items.....	13-1
	Troubleshooting Flowcharts	13-2
	Problems and Countermeasures.....	13-4
13-2	Correcting Errors	13-9
	Dealing with Servo Drive Errors	13-12
	Troubleshooting Errors That Occur When Connected to Remote I/O Slaves	13-14
13-3	Error Indicators.....	13-16
13-4	Error Flag Configuration	13-34
	Error Flags Related to PCU Control	13-34
	Error Flags Related to EtherCAT Communications.....	13-35
13-5	Reading Error Codes.....	13-38
13-6	Error Code List	13-40
13-7	Warnings and Overflows	13-54
	Overflows/Underflows.....	13-54

Table Of Contents

13-8	Resetting Errors.....	13-55
	First Word in Memory Area.....	13-55
	Error Reset Bits	13-56
	Error Flags.....	13-56
	Timing Chart.....	13-60
13-9	Error Indications as a CPU Bus Unit.....	13-61

Section 14 Maintenance and Inspection

14-1	Items to Inspect.....	14-1
	Items to Inspect Periodically	14-1
	Tools Required for Inspection.....	14-2
14-2	Handling Precautions.....	14-3
14-3	PCU Replacement Procedure.....	14-4
	Replacing the PCU with the Simple Backup Procedure.....	14-4
	Replacing the PCU with the CX-Programmer	14-4

Appendix

Appendix-1	Performance List	A-1
	Startup Time	A-1
	Command Response Time.....	A-1
	External Interrupt Response Time.....	A-2
	Input/Output Response Time.....	A-3
	Effect on the Cycle Time of the CPU Unit	A-6
Appendix-2	Comparison to Previous Position Control Units	A-7
	Comparison to Previous Models.....	A-7

Index

1

Product Overview

This section describes the features and operating procedures for the Position Control Units (PCUs) and also provides an overview of EtherCAT, information on unit versions, and other basic information on the PCUs.

1-1	Features	1-1
1-2	System Configuration.....	1-4
1-3	Basic Functions	1-5
1-4	Basic Operating Procedures.....	1-11
1-5	Specifications.....	1-19
1-6	Unit Versions.....	1-29
1-7	Applicable Directives.....	1-34
1-8	Control System Configuration and Principles	1-35
1-9	Support Software	1-37

1-1 Features

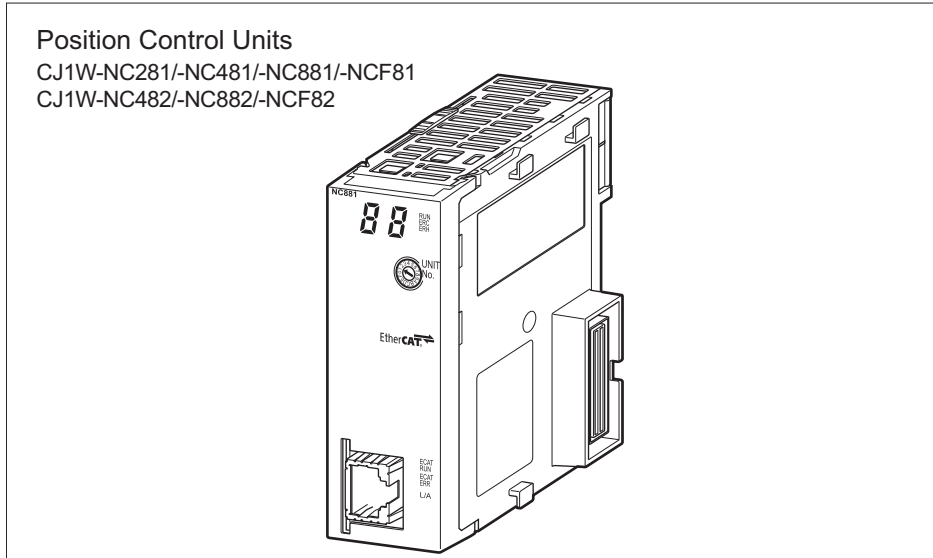

The SYSMAC CJ1W-NC281/481/881/F81/482/882/F82 Position Control Units were designed for use in SYSMAC CJ-series PLCs. They support EtherCAT communications.

The PCUs use 100-Mbps EtherCAT communications to enable high-speed, high-precision position control. They also provide a wide range of positioning functions.



Reference

The PCU uses the master functionality of EtherCAT communications to control EtherCAT-compatible Servo Drives.

Therefore, the different terms are used in this manual when describing EtherCAT communications master functionality and when describing position control functionality for Servo Drives, as shown in the following table.

EtherCAT communications master functionality	Servo Drive position control functionality
Slave	Servo Drive
Node	Axis
Node address	Axis number

Features

The PCUs provide the following features:

High-speed Starting with a Network Response Time of 0.4 ms Maximum

With 100-Mbps EtherCAT communications, positioning can be started in as little as 0.4 ms^{*1}

The wiring required for motion networks is reduced and digital processing of information is increased, while high-speed starting reduces takt time.

Support for Servomotors with Absolute Encoders

The PCUs can be used together with OMRON's OMNUC G5-series Servomotors with Absolute Encoders. Using a Servomotor with an Absolute Encoder eliminates the need to search for the origin at startup, which reduces the preparation time required to start operation.

Monitor the Deviation between Axes during Linear Interpolation

The PCU can monitor the feedback positions for between 2 and 4 axes during linear interpolation. This enables detecting errors when the deviation between axes exceeds a set value.

A Wide Range of Positioning Operations

Linear and circular interpolation are now possible. You can also switch back and forth between position control (CSP) and speed control (CSP). A selection of acceleration/deceleration methods for continuous pattern positioning also makes it possible to satisfy diverse application needs.

Memory Operation

The same memory operation function as the one supported by the PCUs with Pulse Outputs (CJ1W-NC□□4) has been implemented.

Assessing conditions and controlling repetitions can be performed in the PCU to reduce the amount of ladder programming and shorten takt time.

Memory operation can be used to achieve various types of position control without affecting the cycle time of the CPU Unit.

Same Control Interface as PCUs with Pulse Outputs

The bits and flags used in the interface that controls the Servo Drives for manual operation or direct operation are the same as those for PCUs with Pulse Outputs (CJ1W-NC□□4).

Therefore, even if you use both PCUs with EtherCAT Communications and PCUs with Pulse Outputs for different types of Servo Drives, you can use the same user programming for the interface.

*1. Applies when starting one axis with a special PCU instruction and a CJ2M or CJ2H CPU Unit with unit version 1.3 or later.

Positioning Functions That Are Even Easier to Use

You can set and monitor parameters in command units that are the same as the mechanical unit system to simplify PCU application.

Parameters can also be set in a rotation coordinate system to enable easier setting of index and feeder operations.

High-speed EtherCAT Communications

EtherCAT is an open ultra-high-speed industrial network system that conforms to the IEEE 802.3 Ethernet standard. Each node transfers the Ethernet frames at high speed to achieve shorter communications cycle times. Clock data is also shared to achieve high-precision synchronized control with low communications jitter.

Support for EtherCAT Slaves

In addition to servo control, inverters, vision sensors, and other I/O devices that support EtherCAT can be connected.

Using the CJ1W-NC482/882/F82 PCUs, up to 80 nodes including Servo Drives can be connected (when using CJ1W-NCF82).

Support for the Synchronous Data Link Function

The Synchronous Data Link function is available when the CJ1W-NC□82 PCU (unit version 1.3 or later) is used in conjunction with a CJ2 series CJ2H-CPU□□ CPU Unit (unit version 1.4 or later).

In addition, when used in conjunction with a G5-series R88D-KN□□-ECT Servo Drive (version 2.0 or later), the PCU can provide speed control (CSV)/torque control (CST) based on control commands updated in the Synchronous Data Link Area.

The PCU also supports the Electric Shaft function (CSP) that performs synchronized axis control based on the multiplication factor configured for any axis in the same unit.

1-2 System Configuration

The PCU receives control signals from other devices (including control panels) and commands from the ladder programming in the CPU Unit to control positioning through Servo Drives.

The control signals include forward limit inputs, reverse limit inputs, origin inputs, origin proximity inputs, emergency stop inputs, and interrupt inputs.

System Configuration Example for the CJ1W-NC882

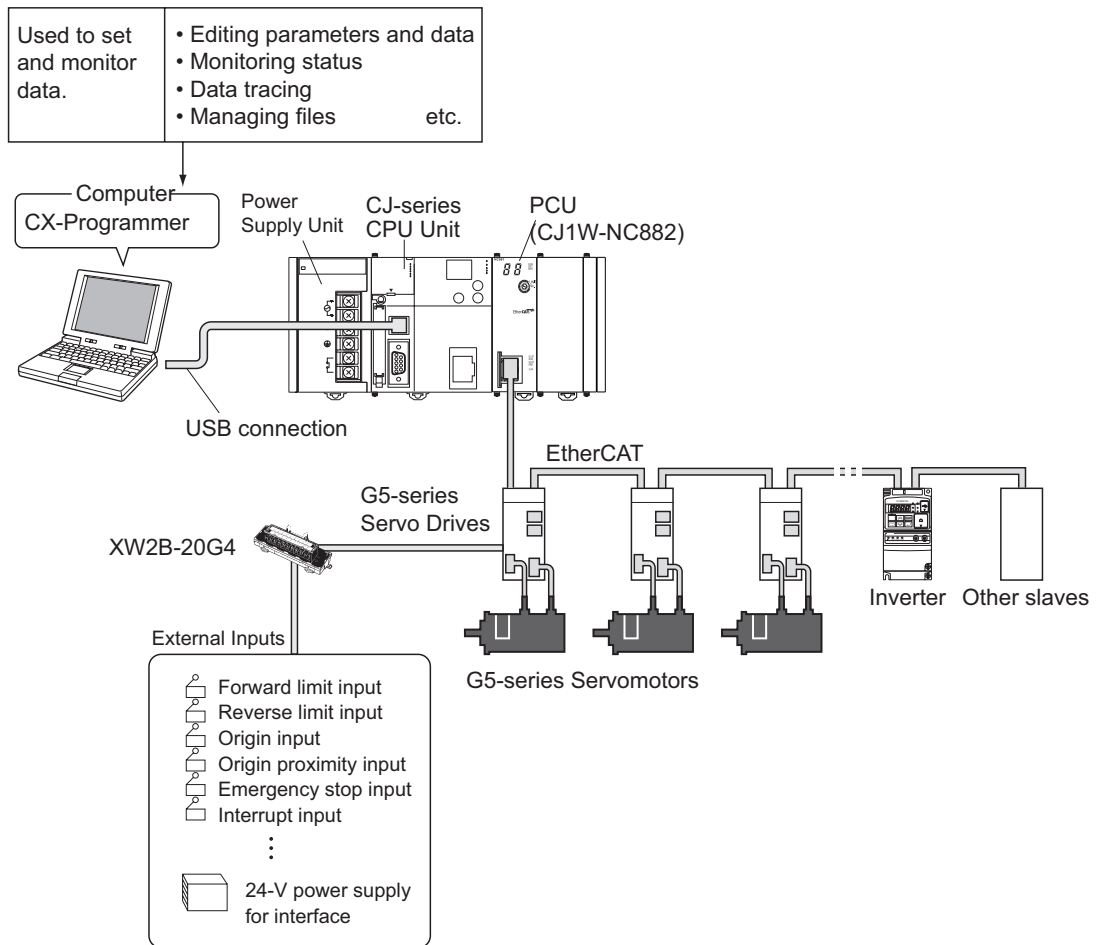

1-3 Basic Functions

The PCU can be connected to EtherCAT-compatible OMNUC G5-series Servo Drives to achieve various position control functions.

A remote I/O master function is also provided for EtherCAT-compatible devices supported by the PCU.

Positioning Functions

The PCU supports the following positioning functions when it is connected to EtherCAT-compatible OMNUC G5-series Servo Drives.

Function		Direct operation	Memory operation	Remarks
Position control	Absolute movements	○	○	
	Relative movements	○	○	
	Interrupt feeding for absolute movements	○	○	
	Interrupt feeding for relative movements	○	○	
Speed control (CSP)	Speed control	○	○	
	Interrupt feeding for speed control	○	○	
Control changes	Changing target position during operation	○	×	Enabled by multi-starting an axis for direct operation.
	Changing target speed during operation	○	×	Enabled by changing the command speed.
	Changing acceleration/deceleration during operation	○	×	Enabled by changing the acceleration/deceleration time.
	Changing present position	○	×	Enabled by using the present position preset function.
Coordinated multi-axis control	Linear interpolation	×	○	Linear interpolation is possible for up to four axes.
	Circular interpolation	×	○	Circular interpolation is possible for two axes.
	Monitoring deviation between axes	×	○	Supported only during linear interpolation.
Sequence control	Positioning with continuous end patterns	×	○	
	Starting positioning with external inputs	×	○	

Function Classifications by Application

Direct operation is suitable for some applications, while memory operation is suitable for other applications.

Applications for Which Direct Operation Is Suitable

- ♦ Executing PTP positioning from a ladder program
- ♦ Changing the target position, target speed, or other command value whenever necessary during operation

Applications for Which Memory Operation Is Suitable

- ♦ Controlling positioning after entering or teaching target positions in advance
- ♦ Performing continuous speed changes, interpolation of multiple axes, or other operations based on specified operation patterns

Position Control

The PCU can execute both absolute movements, where positioning is performed to absolute positions from the origin, and relative movements, where positioning is performed to positions relative to the present position.

Two positioning methods are also supported: direct operation and memory operation.

Operation patterns include interrupt feeding, where a specified amount of movement is performed in response to an interrupt input before stopping.

Direct Operation

With direct operation, position and speed data are set from the ladder programming in the CPU Unit to perform positioning.

The target speed and position can be changed during positioning operations.

Linear and circular interpolation, however, are not possible when using direct operation.

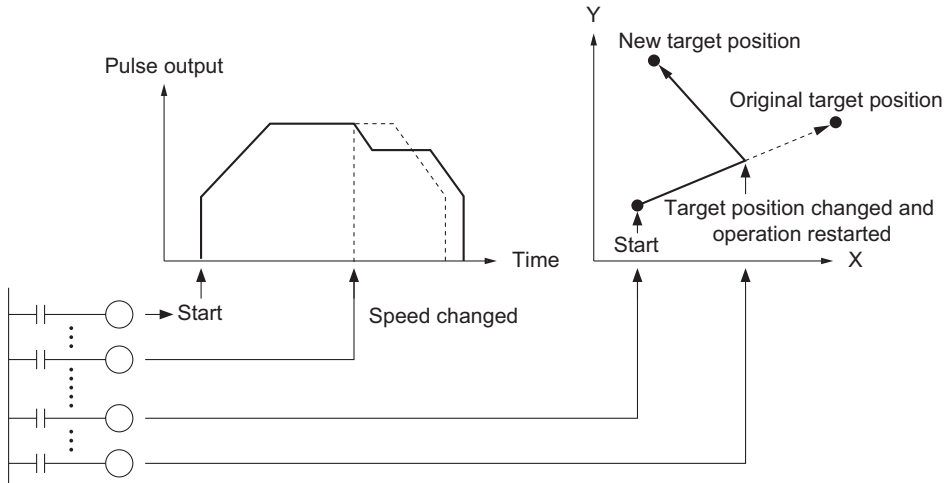

Memory Operation

With memory operation, positioning is performed by specifying data in the PCU from the CPU Unit. You can select the desired positioning patterns, which include independent positioning, automatic positioning, and continuous positioning.

With memory operation, you can perform linear interpolation for up to four axes and circular interpolation for two axes.

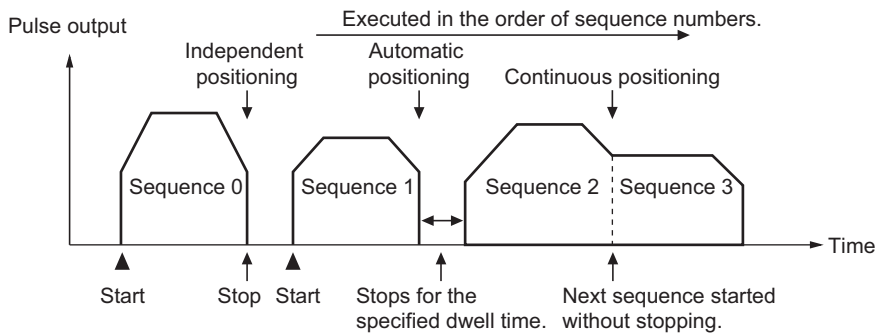

Interrupt Feeding

Interrupt feeding can be used to stop after moving a specified amount when an interrupt input is received during positioning or constant-speed operation.

Interrupt feeding can be performed during either direct operation or memory operation.

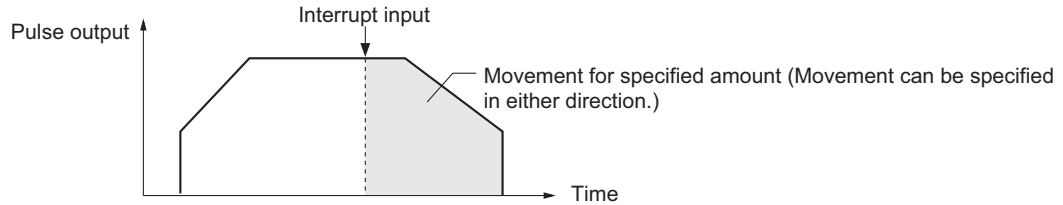

Speed Control

With speed control, a reference is continuously output at a constant speed after starting. A deceleration stop command is used to stop.

There are two types of speed control:

- Speed control that is performed in the CSP mode and available for both direct and memory operations
- Speed control that uses the CSV mode of the Synchronous Data Link function available when the CJ1W-NC□82 PCU (unit version 1.3 or later) is used in conjunction with a CJ2 series CJ2H-CPU□□ CPU unit (unit version 1.4 or later).

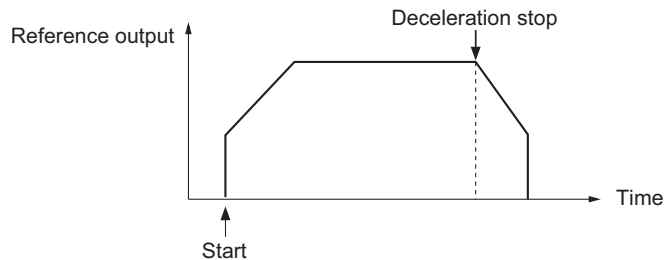

Other Functions

Origin Searches

The origin of the specified axis can be defined.

Jogging

Jogging can be used to start and stop the specified axis at a specified speed.
It can be performed during manual operation.

Teaching

Teaching can be used to record the present position into specified position data after moving to the desired position, e.g., by using jogging.

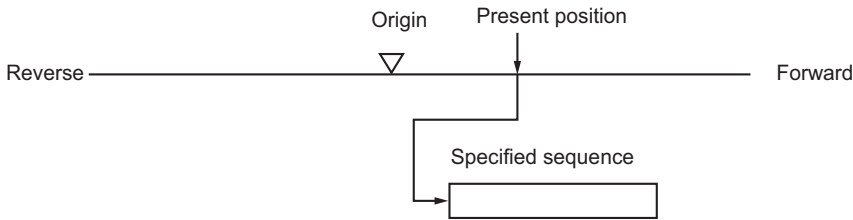

Overrides

Overrides can be used to change the target speed during operation.
They can also be used to change the speed while jogging.

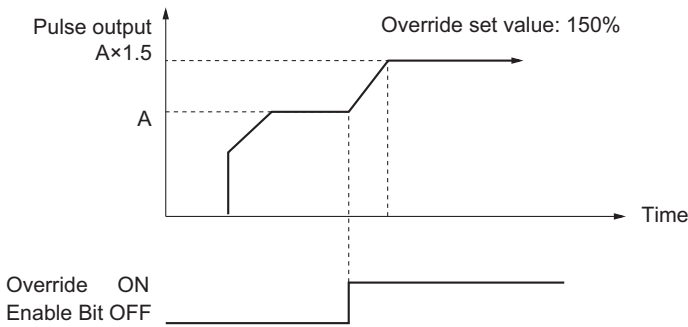

Presetting the Present Position

You can change the present position to any specified value.

Backlash Compensation

Backlash compensation can be set to correct for play in the mechanical system.

The PCU uses the backlash compensation function of the OMNUC G5-series Servo Drive.

Remote I/O master function

The PCU can be connected to EtherCAT-compatible devices other than OMNUC G5-series Servo Drives.

I/O memory in the PLC is allocated to the I/O data of the connected device and I/O is controlled from the PLC via EtherCAT communications.

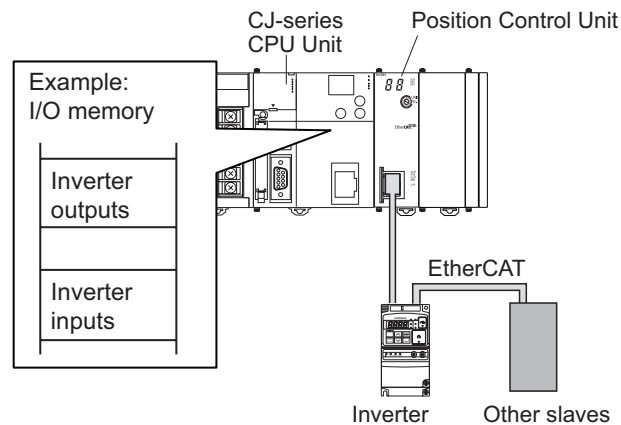

For details on the remote I/O master function, refer to 2-2 *EtherCAT Functions* on page 2-4.



Reference

Even the CJ1W-NC□81 can be connected to slaves other than Servo Drives. In this case, the Direct Operation Command Memory Area (12 output words/axis), Axis Status Memory Area (13 input words/axis), and Expanded Monitor Memory Area (16 words/axis) in the Axis Operation Memory Areas are used as output and input memory areas.

1-4 Basic Operating Procedures

This section provides the basic operating procedures for the PCU.

Basic Flow of Operation

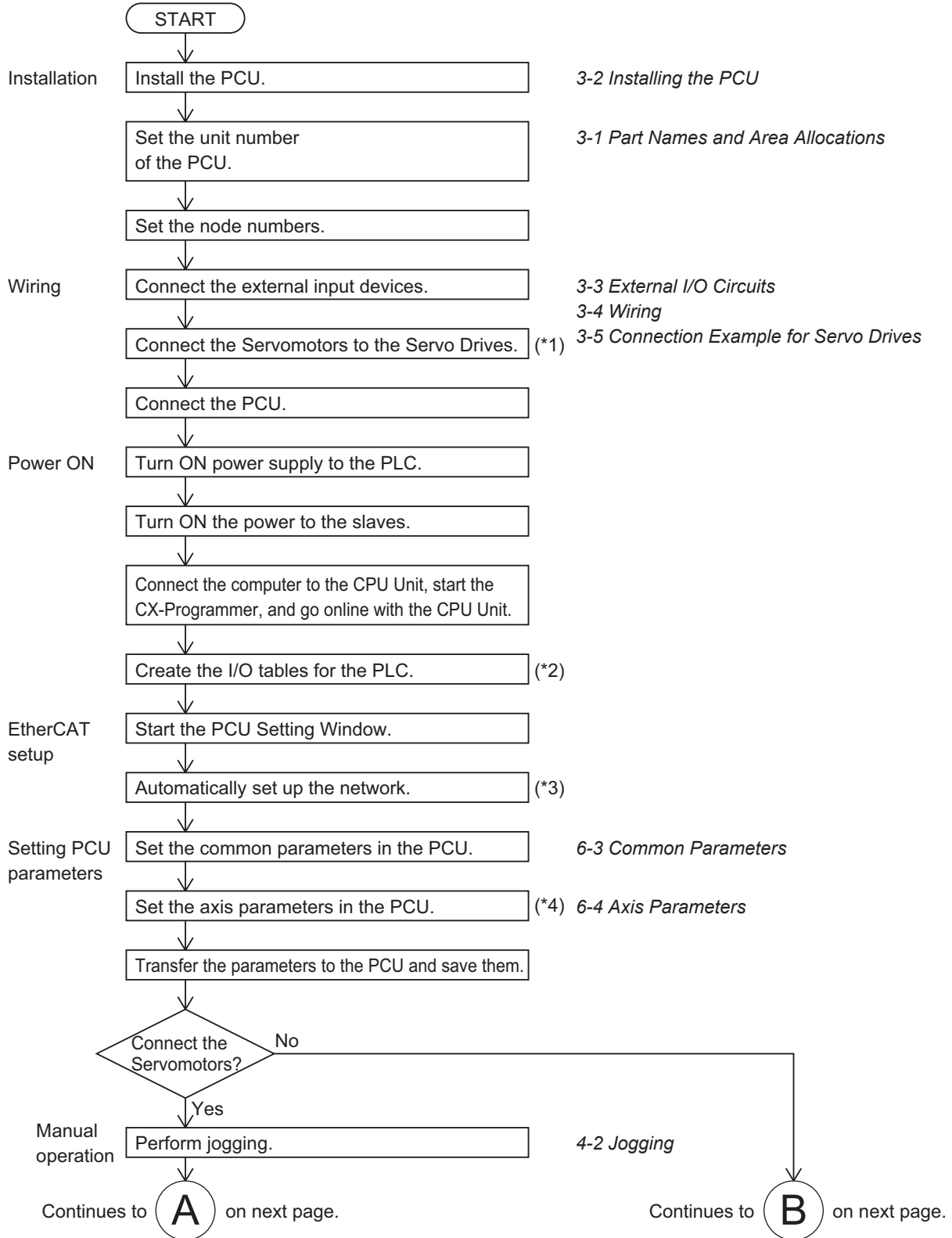

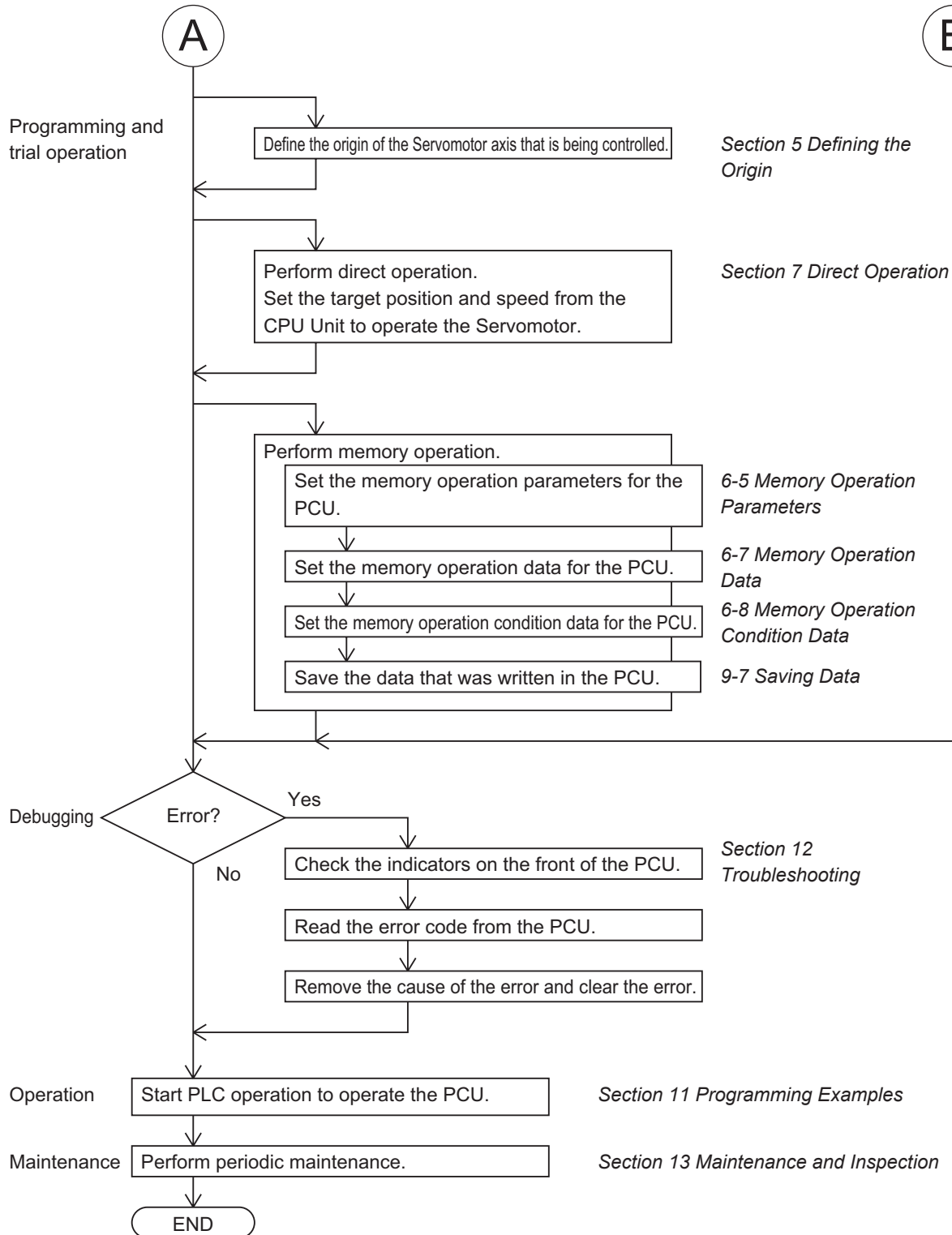

- *1. Only if connected to an OMNUC G5-series Servomotor.
(Refer to the *OMNUC G5-series AC Servomotors/Servo Drives with Built-in EtherCAT Communications User's Manual* (Cat. No. I573) for information on wiring.)
- *2. For details, refer to the manuals for the CPU Unit.
- *3. The network can also be configured offline.
- *4. Only if connected to an OMNUC G5-series Servomotor.

Going Online from the CX-Programmer

Use the following procedure to connect the CX-Programmer online with the PLC.
 CX-One Version 4.0 or later is needed to configure the PCU.

1. Start the CX-Programmer and highlight Auto Online on the PLC Menu of the CX-Programmer.

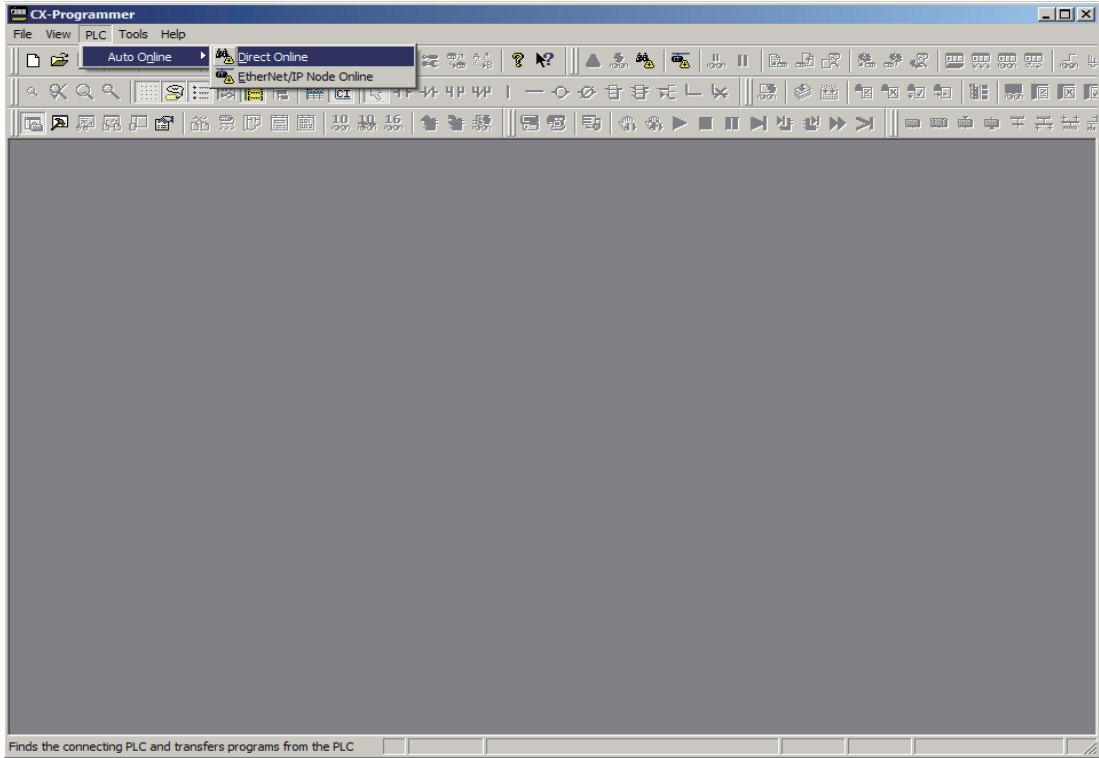

2. Select Direct Online.

The Direct Online Dialog Box appears.

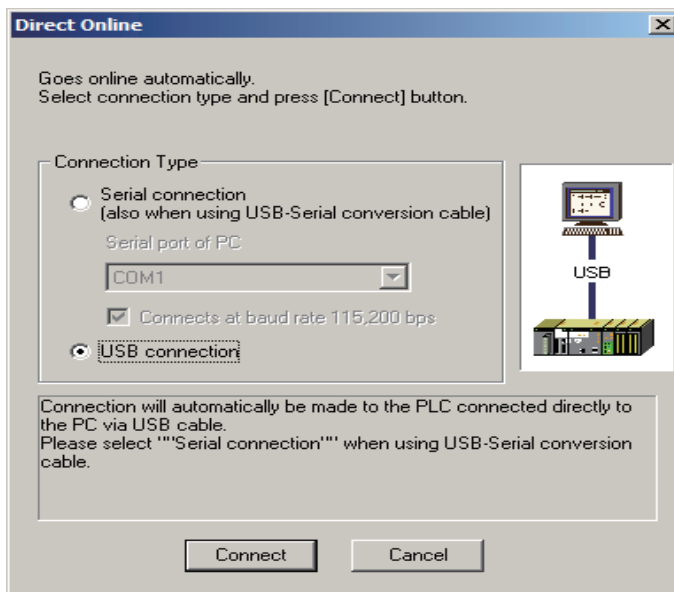

3. Select the connection method and click the Connect Button.

To have the program uploaded to the computer after automatically connecting online, click the Yes Button. Otherwise, click the No Button.

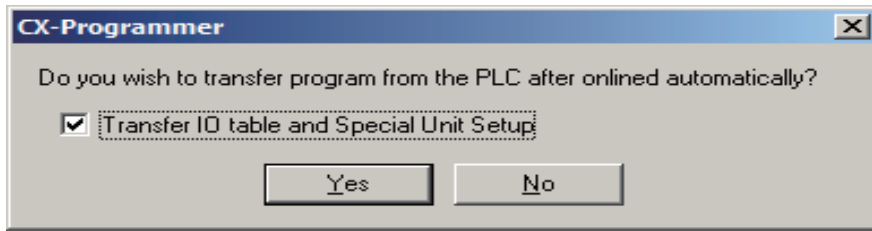

The CX-Programmer will be automatically connected to the PLC.

Setting I/O Tables

This section describes how to set the I/O tables for the PLC.

1. Double-click IO Table and Unit Setup in the project tree of the CX-Programmer.

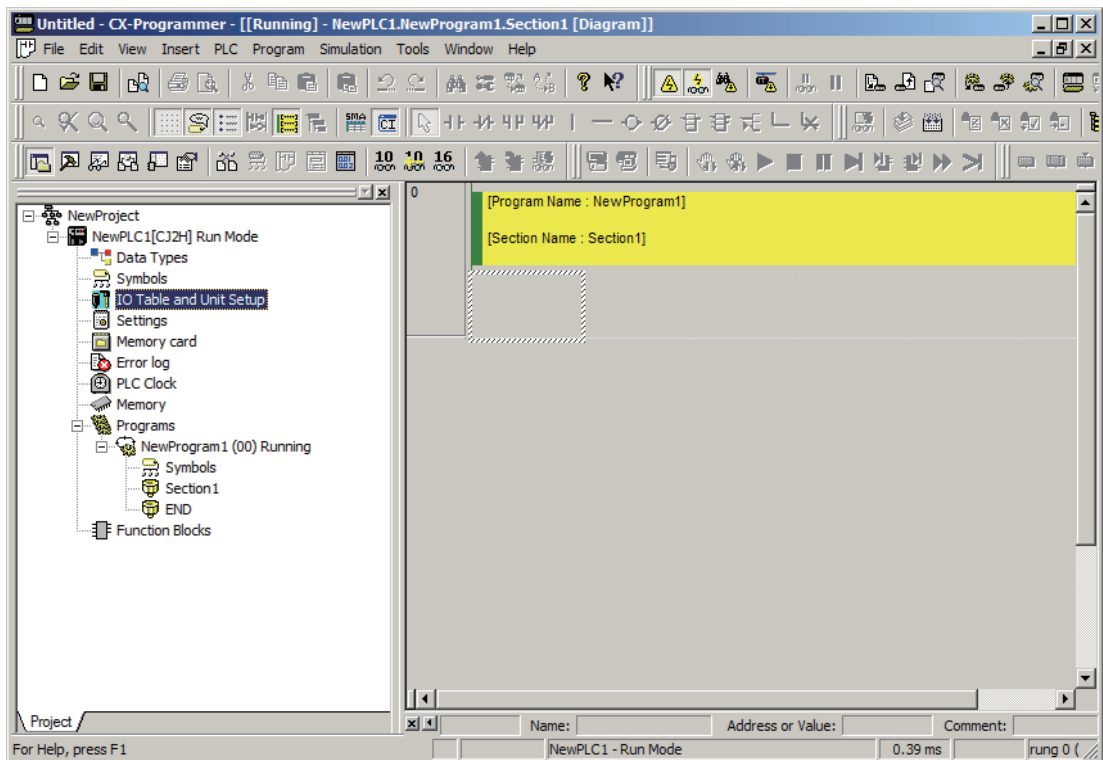

2. The IO Table Window will appear. Set and check the I/O tables.

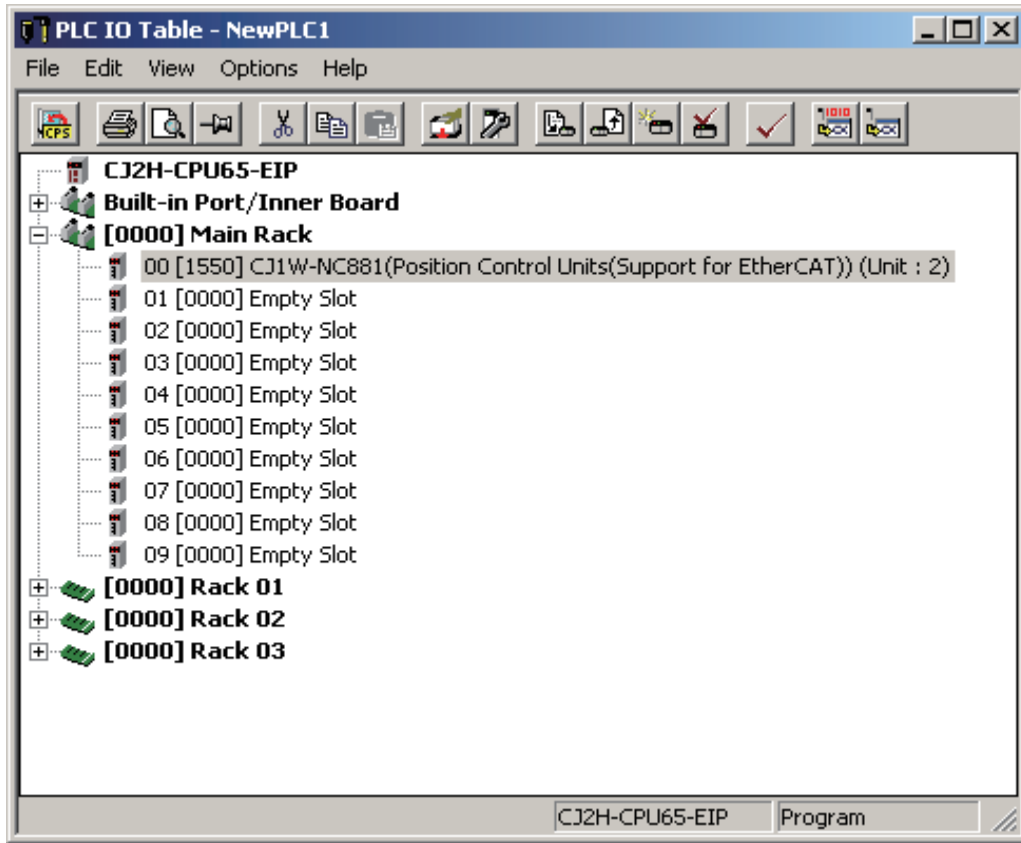

Double-click the PCU model number on the Rack displayed in the IO Table Window to open the PCU Setting Window (shown on the next page).

Automatic Network Setup

The automatic network setup function automatically sets the parameters for EtherCAT communications in the PCU.



Reference

To open the PCU Setting Window, double-click the PCU model number on the Rack displayed in the IO Table Window.

1. Select Network Auto Setup from the Network Menu in the PCU Setting Window.

The following dialog box will appear. If it is OK to continue, click the OK Button.

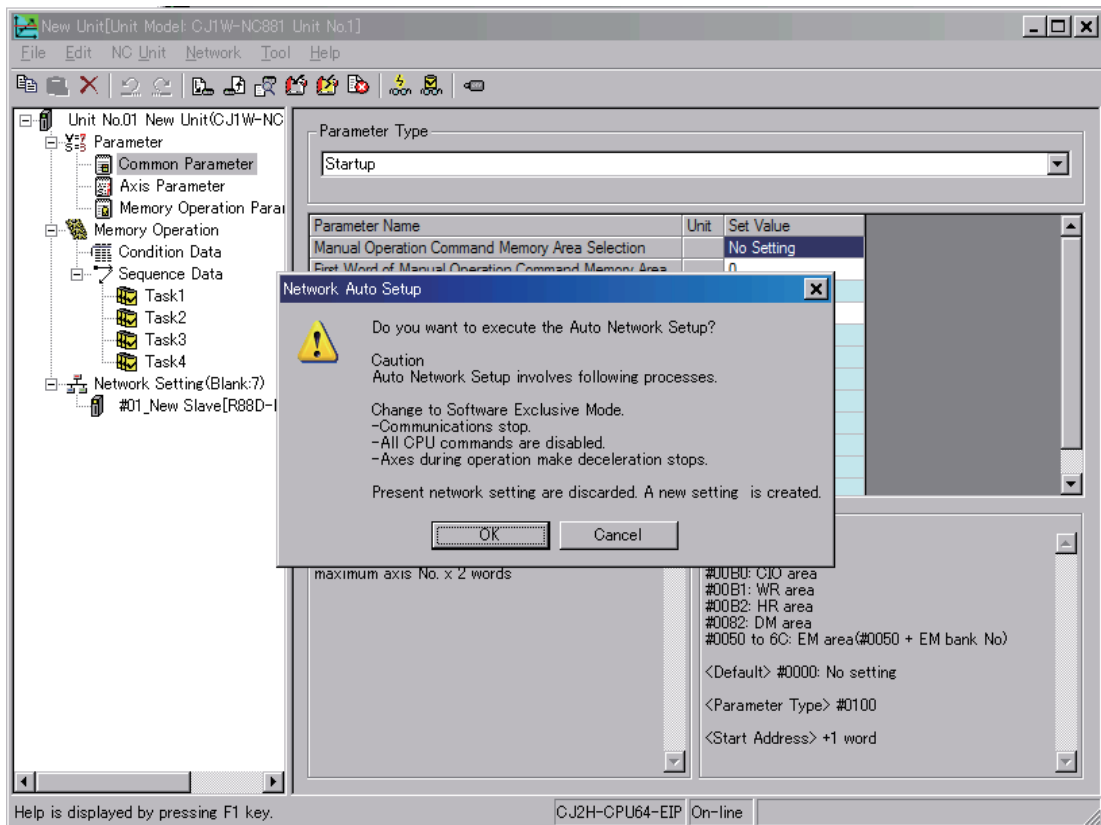

1-4 Basic Operating Procedures

- The network configuration will be set up automatically.
If everything is correct, click the OK Button.

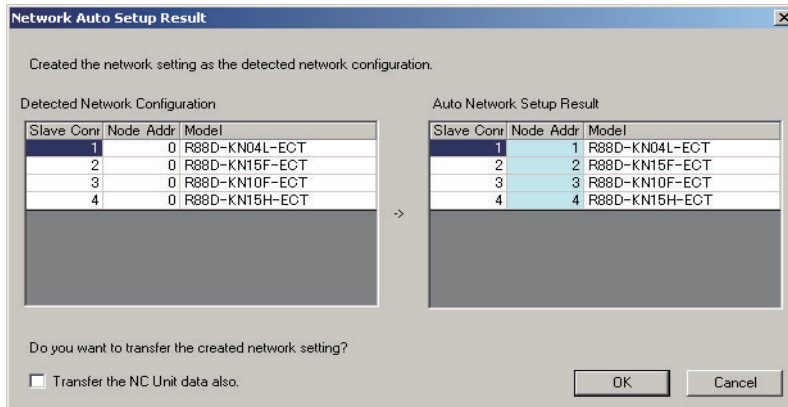

Setting Parameters

Use the following procedure to set the common parameters and the axis parameters. This procedure is an example for the common parameters.

- Select Common Parameter in the project tree in the PCU Setting Window. The Common Parameter Editing Window will appear. Set the parameters.

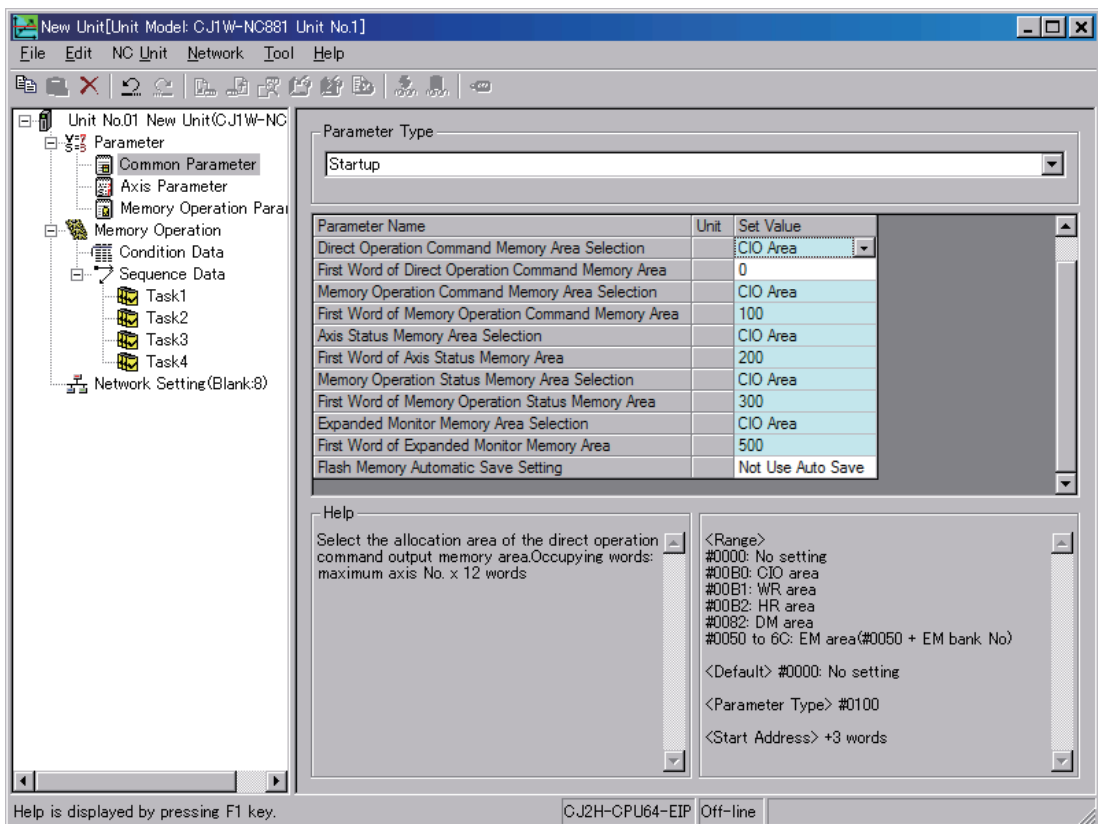

2. When you have set all the required parameters, transfer the setup data to the PCU. Select Transfer [PC to NC] from the NC Unit Menu.

The following dialog box will appear. Select the data to transfer and click the OK Button.

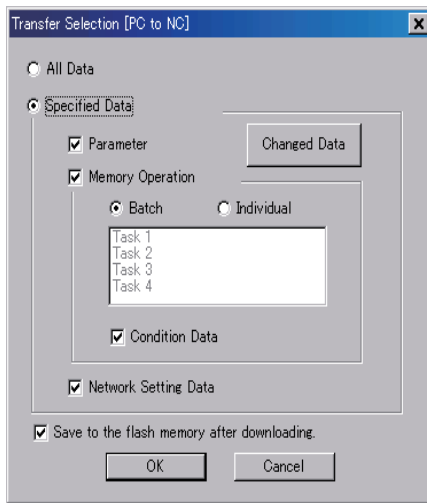

1-5 Specifications

General Specifications

Item	CJ1W-NC281/NC481/NC881/NCF81/NC482/NC882/NCF82
Enclosure	Mounted in a panel
Grounding method	Ground to less than 100 Ω
Dimensions	90 × 65 × 31 mm (H × D × W)
Weight	110 g max.
Internal current consumption	460 mA max. at 5 VDC
Ambient operating temperature	0 to 55°C
Ambient operating humidity	10% to 90% (RH)
Atmosphere	No corrosive gases
Ambient storage temperature	-20 to 70°C
Altitude	2,000m max.
Pollution degree	2 or less: Conforms to JIS B3502 and IEC61131-2.
Noise resistance	2 kV on power supply line (Conforms to IEC 61000-4-4.)
Overvoltage category	Category II: Conforms to JIS B3502 and IEC61131-2.
EMC immunity level	Zone B
Vibration resistance	Conforms to JIS C60068-2- 6. 5 to 8.4 Hz, 3.5-mm amplitude, 8.4 to 150 Hz, acceleration: 9.8 m/s ² in X, Y, and Z directions for 100 minutes (Time coefficient: 10 minutes × coefficient factor 10 = total time 100 min.)
Shock resistance	Conforms to JIS C60068-2-27. 147 m/s ² , 3 times each in X, Y, and Z directions
Applicable standards	Conforms to cULus and EC Directives.

All other specifications conform to the general specifications of the SYSMAC CJ Series.

Characteristics

Item		Models			
		CJ1W-NC281	CJ1W-NC481	CJ1W-NC881	CJ1W-NCF81
Applicable PLCs		SYSMAC CJ Series			
Settable unit numbers		0 to F (unit number as a CPU Bus Unit)			
Maximum number of Units		10 Units per Rack, 16 Units per PLC (Can be used on Expansion Racks.)			
Allocated I/O words	PCU Control Memory Areas	25 words in CPU Bus Unit Area			
	Axis Operation Memory Areas	43 words for each node (2 + 12 output words and 13 + 16 input words) in specified words in the CIO, Work, DM, or EM Area			
	Memory Operation Memory Areas	7 words for each task (3 output words and 4 input words) in specified words in the CIO, Work, DM, or EM Area			
Controllable Servo Drives ^{*1}		OMNUC G5-series Servo Drives with Built-in EtherCAT Communications			
Control method		Control commands using EtherCAT communications			
Number of controlled axes		2 axes	4 axes	8 axes	16 axes
Maximum command output speed		104 Mpps ^{*2}			
Control units	Setting unit	Pulses, millimeters, inches, or degrees			
	Unit multiplier ^{*3}	×1, ×10, ×100, ×1,000, or ×10,000			
	Electronic gear ratio ^{*3}	Unit version 1.1 or earlier: 1/1 to 1,048,576/1,048,576 Unit version 1.3 or later: 1/1 to 4,294,967,295/4,294,967,295			
Positioning functions		Memory operation or direct operation			
Single axis control	Position control	2 axes	4 axes	8 axes	16 axes
	Speed control	2 axes	4 axes	8 axes	16 axes
Interpolated control	Linear interpolation	2 axes max.	4 axes max.	4 axes max.	4 axes max.
	Circular interpolation	2 axes	2 axes	2 axes	2 axes
Memory operation	Maximum number of tasks	2	4	4 ^{*4}	4 ^{*4}
	Sequence functions	JUMP, FOR-NEXT (50 layers/task), PSET, and PRSET			
	Dwell timers	500/task, 0 to 10.00 s (Set in increments of 0.01 s.)			
Position command values	Data	−2,147,483,648 to 2,147,483,647 command units ^{*5}			
	Number of position command values	500/task			
Speed command values	Data ^{*6}	Position control: 1 to 2,147,483,647 command units/s Speed control: −2,147,483,648 to 2,147,483,647 command units/s			
	Number of speed command values	500/task			
Acceleration times	Data	0 to 250,000 ms			
	Number of acceleration times	500/task			
Deceleration times	Data	0 to 250,000 ms			
	Number of deceleration times	500/task			

1-5 Specifications

Item	Models			
	CJ1W-NC482	CJ1W-NC882	CJ1W-NCF82	
Applicable PLCs	SYSMAC CJ Series			
Settable unit numbers	0 to F (unit number as a CPU Bus Unit)			
Maximum number of Units	10 Units per Rack, 16 Units per PLC (Can be used on Expansion Racks.)			
Allocated I/O words	PCU Control Memory Areas	25 words in CPU Bus Unit Area		
	Axis Operation Memory Areas	43 words for each node (2 + 12 output words and 13 + 16 input words) in specified words in the CIO, Work, DM, or EM Area		
	Memory Operation Memory Areas	7 words for each task (3 output words and 4 input words) in specified words in the CIO, Work, DM, or EM Area		
	I/O Memory Areas	1,300 words maximum (Outputs: 640 words, inputs: 640 words, communications status: 20 words) in specified words in the CIO, Work, DM, or EM Area		
Controllable Servo Drives ^{*1}	OMNUC G5-series Servo Drives with Built-in EtherCAT Communications			
Control method	Control commands using EtherCAT communications			
Number of controlled axes	4 axes	8 axes	16 axes	
Maximum command output speed	104 Mpps ^{*2}			
Control units	Setting unit	Pulses, millimeters, inches, or degrees		
	Unit multiplier ^{*3}	×1, ×10, ×100, ×1,000, or ×10,000		
	Electronic gear ratio ^{*3}	Unit version 1.1 or earlier: 1/1 to 1,048,576/1,048,576 Unit version 1.3 or later: 1/1 to 4,294,967,295/4,294,967,295		
Positioning functions	Memory operation or direct operation			
Single axis control	Position control	4 axes	8 axes	16 axes
	Speed control	4 axes	8 axes	16 axes
Interpolated control	Linear interpolation	4 axes max.	4 axes max.	4 axes max.
	Circular interpolation	2 axes	2 axes	2 axes
Memory operation	Maximum number of tasks	4 tasks	4 tasks ^{*4}	4 tasks ^{*4}
	Sequence functions	JUMP, FOR-NEXT (50 layers/task), PSET, and PRSET		
	Dwell timers	500/task, 0 to 10.00 s (Set in increments of 0.01 s.)		
Position command values	Data	-2,147,483,648 to 2,147,483,647 command units ^{*5}		
	Number of position command values	500/task		
Speed command values	Data ^{*6}	Position control: 1 to 2,147,483,647 command units/s Speed control: -2,147,483,648 to 2,147,483,647 command units/s		
	Number of speed command values	500/task		
Acceleration times	Data	0 to 250,000 ms		
	Number of acceleration times	500/task		
Deceleration times	Data	0 to 250,000 ms		
	Number of deceleration times	500/task		

*1. A controllable Servo Drive is Servo Drive for which you can use the position control functions of the PCU.

*2. This is the maximum speed command when converted to pulses

*3. Command units can be set for each axis according to the electronic gear ratio and unit multiplier.

*4. Up to four axes can be controlled by each task.

*5. Setting is possible between 2,147,483,648 and 2,147,483,647 pulses.

*6. The command can be set to up to 104,857,600 pps when converted to pulses.

Item		Models				
		CJ1W-NC281	CJ1W-NC481	CJ1W-NC881	CJ1W-NCF81	
Auxiliary functions	Overrides	0.01% to 500.00% (Can be set for each axis.)				
	Software limits	-2,147,483,647 to 2,147,483,646 command units (Can be set for each axis.)				
	Backlash compensation	Backlash compensation is performed using the compensation function in the Servo Drive. The setting range depends on the specifications of the Servo Drive.				
	Torque limits	Unit version 1.1 or earlier: Supports only the ability to enable or disable the torque limits by turning ON or OFF the command bits. Unit version 1.3 or later: Supports the ability to change the torque limit data from the Memory Area in addition to the ability to enable or disable the torque limits by turning ON or OFF the command bits.				
Synchronous Data Link function		None				
Control performance	Control cycle	0.5 ms	0.5 ms when using 1 to 2 axes 1 ms when using 3 to 4 axes	0.5 ms when using 1 to 2 axes 1 ms when using 3 to 4 axes 2 ms when using 5 to 8 axes	0.5 ms when using 1 to 2 axes 1 ms when using 3 to 4 axes 2 ms when using 5 to 16 axes	
		Communications cycle	250 μs min.	250 μs min. when using 1 to 4 axes 500 μs min. when using 5 to 8 axes	250 μs min. when using 1 to 4 axes 500 μs min. when using 5 to 10 axes 1.0 ms min when using 11 to 16 axes	
	Starting time* ¹	Direct operation* ² (high-speed PTP)	0.15 to 0.4 ms		0.15 to 0.4 ms when using 1 to 4 axes 0.15 to 0.8 ms when using 5 to 8 axes	0.15 to 0.4 ms when using 1 to 4 axes 0.15 to 0.8 ms when using 5 to 10 axes 0.15 to 1.2 ms when using 11 to 16 axes
		Direct operation* ³ (bits)	0.75 to 1.25 ms	1.25 to 2.25 ms	2.5 to 4.5 ms	3.0 to 5.0 ms
		Memory operation* ³ (linear interpolation)	1.75 to 2.25 ms	3.25 to 4.25 ms	6.5 to 8.5 ms	7.0 to 9.0 ms

Item		Models			
		CJ1W-NC281	CJ1W-NC481	CJ1W-NC881	CJ1W-NCF81
Control I/O	Communications port	EtherCAT port × 1			
	Output signals	There are no external output signals for external outputs. The following command bits are provided for each axis for Servo Drive control: Deviation Counter Reset Bit, Alarm Reset Bit, Servo Lock Bit, Servo Unlock Bit, and Torque Limit Bits.			
	Input signals	There are no external input signals for external inputs. The following status flags are provided for each axis for Servo Drive control: Origin Input Flag, Servo Drive Alarm Input Flag, and Positioning Completed Input Flag.			
	External interface signals ^{*4}	6 signals (external origin signal, origin proximity signal, forward limit signal, reverse limit signal, emergency stop signal, and interrupt input signal) for each axis			

Item		Models			
		CJ1W-NC482	CJ1W-NC882	CJ1W-NCF82	
Auxiliary functions	Overrides	0.01% to 500.00% (Can be set for each axis.)			
	Software limits	-2,147,483,647 to 2,147,483,646 command units (Can be set for each axis.)			
	Backlash compensation	Backlash compensation is performed using the compensation function in the Servo Drive. The setting range depends on the specifications of the Servo Drive.			
	Torque limits	Unit version 1.1 or earlier: Supports only the ability to enable or disable the torque limits by turning ON or OFF the command bits. Unit version 1.3 or later: Supports the ability to change the torque limit data from the Memory Area/Synchronous Data Link Area in addition to the ability to enable or disable the torque limits by turning ON or OFF the command bits.			
Synchronous Data Link function		Unit version 1.1 or earlier: None. Unit version 1.3 or later: Provides command support for velocity command data, torque command data, torque feedforward data, torque limit data, and velocity limitation value when used in conjunction with a CJ2H-CPU (unit version 1.4 or later).			
Control performance	Control cycle	0.5 ms when using 1 to 2 axes 1 ms when using 3 to 4 axes	0.5 ms when using 1 to 2 axes 1 ms when using 3 to 4 axes 2 ms when using 5 to 8 axes	0.5 ms when using 1 to 2 axes 1 ms when using 3 to 4 axes 2 ms when using 5 to 16 axes	
		Communications cycle	250 μs min.	250 μs min. when using 1 to 4 axes 500 μs min. when using 5 to 8 axes	250 μs min. when using 1 to 4 axes 500 μs min. when using 5 to 10 axes 1.0 ms min. when using 11 to 16 axes
	Starting time ^{*1}	Direct operation ^{*2} (high-speed PTP)	0.15 to 0.4 ms	0.15 to 0.4 ms when using 1 to 4 axes 0.15 to 0.8 ms when using 5 to 8 axes	0.15 to 0.4 ms when using 1 to 4 axes 0.15 to 0.8 ms when using 5 to 10 axes 0.15 to 1.2 ms when using 11 to 16 axes
		Direct operation ^{*3} (bits)	1.25 to 2.25 ms	2.5 to 4.5 ms	3.0 to 5.0 ms
	Memory operation ^{*3} (linear interpolation)	3.25 to 4.25 ms	6.5 to 8.5 ms	7.0 to 9.0 ms	

Item		Models		
		CJ1W-NC482	CJ1W-NC882	CJ1W-NCF82
Control I/O	Communications port	EtherCAT port × 1		
	Output signals	There are no external output signals for external outputs. The following command bits are provided for each axis for Servo Drive control: Deviation Counter Reset Bit, Alarm Reset Bit, Servo Lock Bit, Servo Unlock Bit, and Torque Limit Bits.		
	Input signals	There are no external input signals for external inputs. The following status flags are provided for each axis for Servo Drive control: Origin Input Flag, Servo Drive Alarm Input Flag, and Positioning Completed Input Flag.		
	External interface signals ^{*4}	6 signals (external origin signal, origin proximity signal, forward limit signal, reverse limit signal, emergency stop signal, and interrupt input signal) for each axis		

*1. This is the time from executing a command at the PLC until the command is output on EtherCAT communications. Execution for command bits is in the I/O refresh period.

The starting time depends on the control cycle, communications cycle, and operating conditions. For details, refer to *Command Response Time* on page A-1.

*2. The starting time applies when starting one axis with a special PCU instruction and a CJ2M or CJ2H CPU Unit with unit version 1.3 or later.

*3. These are the internal PCU processing times.

*4. Servo Drive inputs are used.



Precautions for Correct Use

- ◆ With the Synchronous Data Link function, the CJ1W-NC□□4 synchronizes the start timing of internal processing according to the synchronization signal transmitted from the CPU unit at regular intervals. The CJ1W-NC□□82, however, does not support this function and therefore it does not synchronize the start timing of internal processing.
- ◆ To use the Synchronous Data Link function, use a combination with the CJ2H CPU Unit with unit version 1.4 or later.
- ◆ Updating the torque limit data directly from the operation Memory Area/Synchronous Data Link Area requires that the Maximum Torque axis parameter be correctly configured. Also, do not set the maximum torque to too small a value since the torque cannot be higher than your configured value. This should be carefully followed especially when you use vertical axes.
- ◆ Updating the torque feedforward from the Synchronous Data Link requires that the Maximum Torque axis parameter be correctly configured. If a torque feedforward value too large for the Servo Drive to accept is specified with the Synchronous Data Link, the feedforward value will be restricted automatically to the maximum torque value. The Servo Drive will not correctly operate if your specified torque feedforward value is larger than its own maximum torque value.

EtherCAT Communications Specifications

Item	Characteristics						
	CJ1W-NC281	CJ1W-NC481	CJ1W-NC881	CJ1W-NCF81	CJ1W-NC482	CJ1W-NC882	CJ1W-NCF82
Communications standard	IEC 61158 Type12						
Physical layer	100Base-TX (IEEE802.3)						
Connector	RJ45 connector × 1 (shielded)						
Communications media	Category 5 or higher (Recommended: cable with double, aluminum tape and braided shielding)						
Communications distance	100 m max. between nodes						
Topology	Daisy chain only ^{*1}						
EtherCAT master specifications	Class B (minimum master-CoE compatible (no information service for SDO))						
Maximum number of slaves ^{*2}	2 slaves	4 slaves	8 slaves	16 slaves	68 slaves	72 slaves	80 slaves
Node address setting range	1 to 2	1 to 4	1 to 8	1 to 16	1 to 4, 17 to 80 ^{*3}	1 to 8, 17 to 80 ^{*3}	1 to 16, 17 to 80 ^{*3}
Communications cycle ^{*4}	250 μs/500 μs/1ms/2ms						
Process data	Fixed PDO mappings specified for the slaves are used (set using Support Software).						
Mail box (CoE)	Emergency messages, SDO requests, SDO responses, and SDO information (Used for PCU communications control and slave device parameter transfers.)						
LED indicators	ECAT RUN × 1 ECAT ERR × 1 L/A (Link/Activity) × 1						
CiA402 drive profile ^{*5}	<ul style="list-style-type: none"> ♦ Cyclic synchronous position mode ♦ Cyclic synchronous velocity mode ♦ Cyclic synchronous torque mode ♦ Latch probe function ♦ Torque limit function 						

*1. Ethernet hubs cannot be used.

*2. This is the number of slaves, including Servo Drives and remote I/O slaves. The number of slaves that can be connected is limited. For details, refer to *Number of Remote I/O Connections* on page 2-16.

*3. Node addresses 17 to 80 are reserved for remote I/O slaves.

*4. The setting range depends on the number of slaves that are connected and the slave specifications. Refer to *6-2 EtherCAT Communications Settings* on page 6-11 for information on the number of connected slaves, the control cycle, and the communications cycle.

*5. This drive profile is used when connected to an OMNUC G5-series Servo Drive.

Functional Specifications

The following functions are supported when the PCU is connected to an EtherCAT-compatible OMNUC G5-series Servo Drive.

Function		Description	
Control functions	Single axis control	Absolute movements	Positioning is performed by specifying the absolute or relative target position and target speed directly from the ladder program.
		Relative movements	
		Speed control	Feeding at a specified speed is performed by specifying the target speed directly from the ladder program. Speed control is implemented using speed feeding with position control.
		Interrupt feeding	Interrupt feeding can be used to move a specified amount when an interrupt input is received during an absolute movement, a relative movement, or speed control.
		Rotation axis control	Rotation axes that are suitable for feeder and index table control can be controlled. Forward and reverse positioning and shortest route operations are possible.
		Changing target positions and target speeds	The target position or target speed can be changed during an absolute movement, a relative movement, or speed control.
	Multi-axis control	Linear interpolation	The operation of more than one axis is started and stopped simultaneously to move in a straight line to the target position from the starting point of each axis. Linear interpolation supports up to four axes.
		Circular interpolation	The operation of any two axes is controlled to move in a circular arc. Any of three methods can be used to specify a circular arc: specifying the target position and center point, specifying the target position, radius, and direction and specifying the target position and passing point.
	Memory operation	Automatic continuous operation	The target positions, speeds, and operation patterns can be set in advance in the PCU to automatically perform a series of operations. Continuous positioning and speed changes are also possible.
		Sequence functions	Memory operation data provides sequence functions, including repetition of a given operation and starting/stopping operation data by using external inputs. Therefore, the PCU can perform various operation sequences without affecting the ladder programming in the CPU Unit.
Manual operation	Origin searches	External sensors and other means are used to detect the mechanical origin of the system. You can select the origin search operation that is best for your system from 15 different origin search operation patterns.	
	Origin returns	You can return to the point that was defined as the mechanical origin.	
	Presetting the present position	The present position can be changed to a specified value to define the origin.	
	Deceleration stops and emergency stops	An axis that is in operation can be decelerated to a stop or stopped immediately.	
	Jogging	You can jog either forward or in reverse.	
	Inching	You can inch either forward or in reverse.	

Function		Description	
Synchronous Data Link		<p>The CJ1W-NC□82 PCU (unit version 1.3 or later) can perform data exchange with the CPU at regular intervals when used in conjunction with a CJ2H CPU Unit (unit version 1.4 or later).</p> <p>In addition, you can use this function to perform synchronous feeding position, synchronous feeding velocity, and synchronous feeding torque control. Also, optional commands are available for torque feedforward data, torque limit data, and velocity limitation value.</p>	
Auxiliary control functions	Command unit setting	You can set the unit of control for each axis according to the machine.	
	Acceleration/deceleration control	Automatic acceleration/deceleration control	The acceleration/deceleration curve can be automatically created during operation. You can select either a trapezoidal curve or an S-curve based on a tertiary function.
		Changing acceleration/deceleration rates	You can change the rate of acceleration/deceleration during acceleration/deceleration.
		Switching acceleration/deceleration points	You can select one of three methods to connect speeds between different operation patterns during continuous memory operation.
	Overrides	You can increase or decrease the operating speed of the system by a specified factor.	
	Backlash compensation	You can compensate for mechanical play using a parameter.	
	M codes	M codes can be output during memory operation to interlock with external devices.	
	Zone settings	You can set zones and assess when the present position is in a zone. Up to three zones can be set for each axis.	
	Support for absolute encoders	You can build an absolute positioning system by using a Servomotor with an Absolute Encoder. The PCUs can be used together with OMRON's OMNUC G5-series Servomotors with Absolute Encoders.	
	Teaching	<p>You can save the present position as position data for memory operation.</p> <p>You can use either the command present position or feedback present position.</p>	
Torque limit outputs	<p>The torque limit outputs can be used to switch the torque limits of the Servo Drive. They can be turned ON and OFF directly from a ladder program. Torque limits can be automatically switched by using holding for an origin search operation.</p> <p>In addition, you can change the torque limit data from the Synchronous Data Link Area by using the CJ1W-NC□82 (unit version 1.3 or later) in conjunction with a CJ2H CPU Unit (unit version 1.4 or later) and an OMNUC G5-series Servo Drive (version 2.0 or later).</p> <p>Also, you can change the torque limit data from the Memory Area by using the CJ1W-NC□81/NC□82 PCU (unit version 1.3 or later) in conjunction with an OMNUC G5-series Servo Drive (version 2.0 or later).</p>		
Monitoring functions	Software limits	You can set forward and reverse software limits for axis operation. If the target position exceeds a software limit, it will be detected in the command value check that is performed at startup.	
	Monitoring position/speed deviations	You can monitor the position or speed deviation between the command present position and feedback present position to stop axis operation if the deviation becomes too large.	
	Monitoring deviation between axes	In memory operation, you can perform interpolation while monitoring the deviation between axes to stop axis operation if the deviation becomes too large.	

1-6 Unit Versions

The CJ-series Position Control Units (PCUs) have "unit versions".

Unit versions are assigned to manage differences in the PCU functions that result from upgrades.

Confirmation Method

Any of the following three methods can be used to check the unit version.

Confirming on the Product

The unit version of a CJ-series PCU is given on the product nameplate, as shown below.

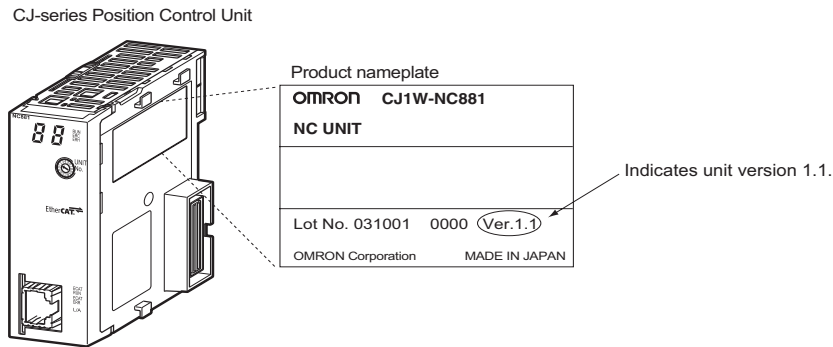

Confirming Unit Versions with Support Software

CX-Programmer can be used to confirm the unit version using the following two procedure.

1. Right-click the Position Control Unit in the IO Table Window and select Unit Manufacturing Information.
2. The following Unit Manufacturing Information Dialog Box will be displayed.

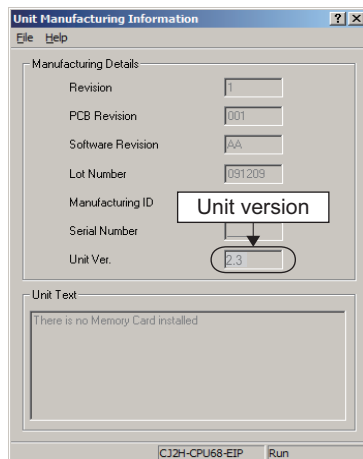

Use the above dialog box to confirm the unit version of the PCU that is connected online.

Using the Unit Version Labels

A unit version label is provided with the PCU.

Attach this label to the front of the PCU to easily differentiate it from PCUs with older unit versions.

Unit Versions

○: Exists, –: Does not exist

Unit	Model	Unit Versions			
		Ver. 1.0	Ver. 1.1	Ver. 1.3	Ver. 1.4
Position Control Units with EtherCAT	CJ1W-NC281	○	○	○	○
	CJ1W-NC481	○	○	○	○
	CJ1W-NC881	○	○	○	○
	CJ1W-NCF81	–	○	○	○
	CJ1W-NC482	–	○	○	○
	CJ1W-NC882	–	○	○	○
	CJ1W-NCF82	–	–	○	○
Compatible CX-Programmer version		Version 9.11 or higher	Version 9.12 or higher	Version 9.32 or higher	Version 9.52 or higher ^{*1}

*1. Check *CX-One Information*. The Common Components must be 2014.09 (September 2014) or later.

Function Support According to Unit Versions

CJ1W-NC□81

○: Supported, –: Not supported

Function	Unit Versions			
	Ver. 1.0	Ver. 1.1	Ver. 1.3	Ver. 1.4
Status Word Expanded Monitor Type	–	○	○	○
I/O communications as type of slave that can be connected	–	○	○	○
Enabling/disabling registered slaves	–	○	○	○
Clearing input data to zero when there is a communications error with a remote I/O slave	–	○	○	○
Electronic gear ratio setting range expansion	–	–	○	○
Origin position latch	–	–	○	○
Ad hoc change of torque limit data using Allocated Memory Areas ^{*1}	–	–	○	○
Ad hoc change of torque limit data/torque feedforward data using the Synchronous Data Link ^{*1 *2}	–	–	–	–
Synchronous Data Link (Electric Shaft function) ^{*1 *2}	–	–	–	–
Synchronous Data Link (Synchronous feeding velocity function) ^{*1 *2}	–	–	–	–
Synchronous Data Link (Synchronous feeding torque function) ^{*1 *2}	–	–	–	–
Absolute Encoder Origin Establishment Timing Setting	–	–	–	○

*1. Whether or not this function is supported depends on the version of the OMNUC G5-series Servo Drive. For details, refer to *Function Support According to OMNUC G5-series Servo Drive Versions* on page 1-32.

*2. Whether or not this function is supported depends on the version of the OMNUC G5-series Servo Drive. For details, refer to *Function Support According to CPU Unit Versions* on page 1-33.

CJ1W-NC□82

○: Supported, –: Not supported

Function	Unit Versions			
	Ver. 1.0	Ver. 1.1	Ver. 1.3	Ver. 1.4
Status Word Expanded Monitor Type	–	○	○	○
I/O communications as type of slave that can be connected	–	○	○	○
Enabling/disabling registered slaves	–	○	○	○
Clearing input data to zero when there is a communications error with a remote I/O slave	–	○	○	○
Electronic gear ratio setting range expansion	–	–	○	○
Origin position latch	–	–	○	○
Ad hoc change of torque limit data using Allocated Memory Areas ^{*1}	–	–	○	○
Ad hoc change of torque limit data/torque feedforward data using the Synchronous Data Link ^{*1 *2}	–	–	○	○
Synchronous Data Link (Electric Shaft function) ^{*1 *2}	–	–	○	○
Synchronous Data Link (Synchronous feeding velocity function) ^{*1 *2}	–	–	○	○
Synchronous Data Link (Synchronous feeding torque function) ^{*1 *2}	–	–	○	○
Absolute Encoder Origin Establishment Timing Setting	–	–	–	○

*1. Whether or not this function is supported depends on the version of the OMNUC G5-series Servo Drive. For details, refer to *Function Support According to OMNUC G5-series Servo Drive Versions* on page 1-32.

*2. Whether or not this function is supported depends on the version of the OMNUC G5-series Servo Drive. For details, refer to *Function Support According to CPU Unit Versions* on page 1-33.

Function Support According to OMNUC G5-series Servo Drive Versions

As indicated in the table below, functions supported by CJ1W-NC□82 PCUs (unit version 1.3 or later) differ depending on the version of the G5 series Servo Drive used in conjunction with the PCU:

○: Supported, –: Not supported

Function		Drive version	
		Ver. 1.□	Ver. 2.0 or later
Synchronous Data Link (Synchronous feeding functions)	Synchronous feeding position (Electric Shaft) function	○	○
	Synchronous feeding velocity function	–	○
	Synchronous feeding torque function	–	○
Ad hoc change of torque limit data using Allocated Memory Areas		–	○
Ad hoc change of torque limit data/torque feedforward data using the Synchronous Data Link		–	○

Function Support According to CPU Unit Versions

As indicated in the table below, functions supported by CJ1W-NC□82 PCUs (unit version 1.3 or later) differ depending on the version of the CPU unit used in conjunction with the PCU:

○: Supported, -: Not supported

Function		CJ2H		CJ1-H/CJ1/ CJ1M/CJ2M
		Ver. 1.3 or earlier	Ver. 1.4 or later	
Synchronous Data Link (Synchronous feeding functions)	Synchronous feeding position (Electric Shaft) function	-	○	-
	Synchronous feeding velocity function	-	○	-
	Synchronous torque command function	-	○	-
Ad hoc change of torque limit data/torque feed-forward data using the Synchronous Data Link		-	○	-



Precautions for Correct Use

You can use axis parameters created in a CJ1W-NC□81/□82 PCU (unit version 1.1 or earlier), but the Maximum Torque axis parameter defaults to 0% (0000 hex). Before you use the ability to make ad hoc changes to the torque limit data from the Allocated Memory Areas or the Synchronous Data Link Area, be sure to configure the maximum torque.

When the Maximum Torque parameter is set to 0% (0000 hex), no torque will be generated.

1-7 Applicable Directives

This section describes concepts related to the EMC Directive and provides precautions.

Conformance to EMC Directive

Applicable Directives

- ♦ EMC Directive

Concepts

EMC Directive

OMRON devices are electrical components that are designed to be built into equipment and manufacturing systems. OMRON devices that comply with the EMC Directive also conform to the related EMC standards* so that they can be more easily built into other devices or the overall machine.

However, different customers manufacture different machines and systems, and EMC performance changes according to the configuration, wiring conditions, layout, and other aspects of the equipment or control panels into which the EC Directive-compliant OMRON products are built. Whether the products conform to the standards in the system used by the customer must therefore be checked by the customer.

- * Of the EMC (electromagnetic compatibility) standards, EN 61000-6-2 specifies EMS (electromagnetic susceptibility), while EN 61000-6-4 specifies electromagnetic interference. The 10-m regulations for radiation emission in EN 61000-6-4 apply.

Conformance to EC Directives

CJ-series products comply with EC Directives. To ensure that the machine or device in which the products are used complies with EC Directives, the products must be installed as follows:

- ♦ The CJ-series PLC must be installed within a control panel.
- ♦ DC power supplies with reinforced insulation or double insulation must be used for DC Power Supply Units and I/O Units.
- ♦ CJ-series PLCs that comply with EC Directives also conform to the common emission standard for EMI (EN 61000-6-4). Radiated emission characteristics (10-m regulations) may vary depending on the configuration of the control panel used, other devices connected to the control panel, wiring, and other conditions.

Therefore, even if you use the EC Directive-compliant CJ-series products, you must still check the overall machine or system for compliance with the EC Directives and take appropriate actions as required.

1-8 Control System Configuration and Principles

This section describes the configuration of the PCU control system and the setting principles of the positioning system.

Control System Configuration

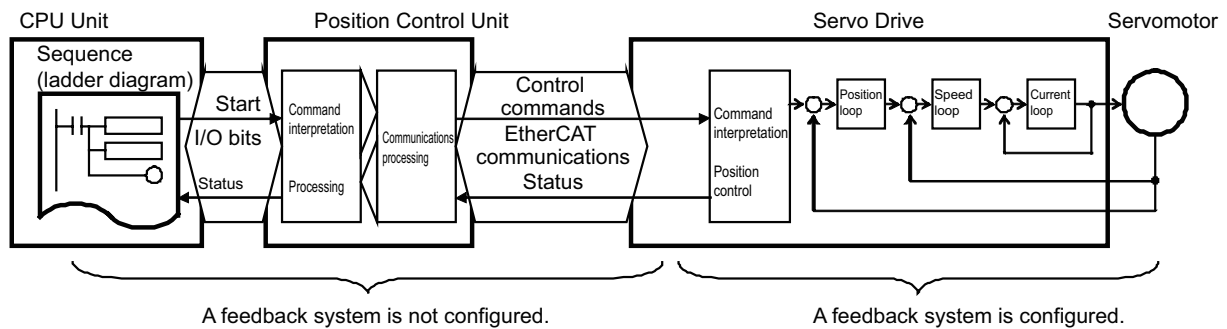

The control system built with the PCU controls motor operation basically with a semi-closed loop. With semi-closed loop control, an encoder attached to the motor detects motor rotations for command values and provides them as feedback of machine travel distances. The deviation between command values and actual motor rotation is calculated and control is performed to bring this deviation to zero.

In a system configuration using the PCU, feedback information is not used for commands from the ladder program in the CPU Unit to the PCU and Servo Drives. A feedback system is built within the Servo Drives.

Setting Principles of Positioning System

Consider using a Servomotor to perform positioning with the following system.

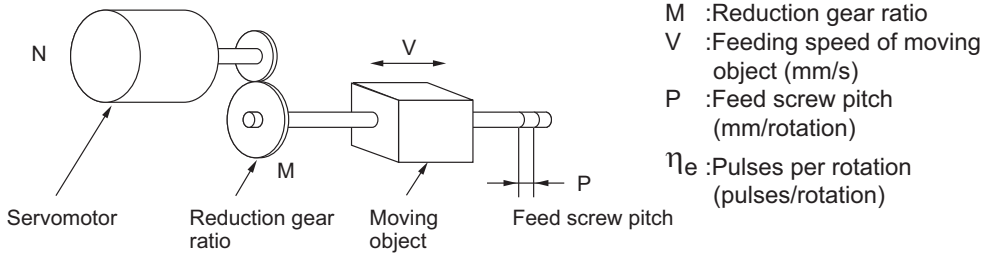

- M :Reduction gear ratio
- V :Feeding speed of moving object (mm/s)
- P :Feed screw pitch (mm/rotation)
- η_e :Pulses per rotation (pulses/rotation)

The following formula gives the travel distance per pulse relative to the motor driver. This is called the pulse rate.

$$\begin{aligned} \text{Pulse rate} &= \frac{\text{Feed screw pitch}}{(\text{Pulses per rotation}) \times (\text{Reduction ratio})} = \frac{P \text{ (mm/rotation)}}{\eta_e \text{ (pulses/rotation)} \times M} \\ &= \frac{P}{\eta_e \times M} \text{ (mm/pulse)} \end{aligned}$$

The number of pulses required to move the load by L (mm) is calculated as follows from the pulse rate:

$$\text{Number of pulses} = \frac{\text{Travel distance}}{\text{Pulse rate}} = \frac{L \text{ (mm)}}{\frac{P}{\eta_e \times M} \text{ (mm/pulse)}} = \frac{\eta_e \times M \times L}{P} \text{ (pulses)}$$

The pulse speed required to move the load at the feeding speed of V mm/s is calculated as follows:

$$\text{Pulse speed} = \frac{\text{Feeding speed}}{\text{Pulse rate}} = \frac{V \text{ (mm/s)}}{\frac{P}{\eta_e \times M} \text{ (mm/pulse)}} = \frac{\eta_e \times M \times V}{P} \text{ (pulses/s)}$$

The PCU outputs the above number of pulses and pulse speed as the position command value and speed command value to perform position control.

1-9 Support Software

The CX-Programmer is used to set data, perform manual operation, and otherwise control and monitor the PCU. CX-Programmer version 9.0 or higher is required to set the PCU.

Refer to *Unit Versions* on page 1-30 for information on compatible unit versions.

The following operations are possible from the CX-Programmer.

- ♦ Checking wiring
- ♦ Manual operation
- ♦ Defining the origin
- ♦ Setting data
- ♦ Transferring and saving the data
- ♦ Monitoring
- ♦ Checking the error log

Functions

The CX-Programmer provides the following functions for the PCU.

Name	Function	Description
Editing the project	Creating a project	A project file (*.cpx) is created. Refer to the operating procedures for the CX-Programmer.
	Adding a PCU	A PCU is added to the I/O tables. Refer to the operating procedures for the CX-Programmer.
	Saving/reading the project	The project file (*.cpx) is saved. Refer to the operating procedures for the CX-Programmer.
Editing data	Editing parameters	The common parameters and axis parameters for the PCU are edited. Refer also to editing function for origin search settings.
	Editing memory operation	The PCU memory operation parameters, memory operation condition data, and memory operation sequence data is edited.
	Initialization	Initializes the data in the CX-Programmer.
Importing/exporting data	Importing	PCU data is imported. Right-click the PCU in the IO Table Window and select Load Parameters.
	Exporting	PCU data is exported. Right-click the PCU in the IO Table Window and select Save Parameters.
Printing	Printing	Data can be printed.
	Print preview	The results of printing is checked on the computer monitor before printing.

Name	Function	Description
Online operations	Transferring/verifying data	PCU data is downloaded, uploaded, or compared.
	Saving to flash memory	Data that was downloaded to the PCU is saved in flash memory.
	Initialize memory	All data in the PCU is initialized.
	Test run	Jogging, inching, direct operation, origin searches, and wiring checks are performed.
	Monitoring	PCU status and error information is monitored.
	Monitoring memory operation	PCU status and error information is monitored during memory operation.
	Error log	The error log is displayed.
	Device information	The model number and version of the connected Unit is displayed.
	Monitor network	The slave communications status is monitored.
	Verify network	The network configuration information on the computer is compared with the actual network configuration.
Other operations	Creating a symbol table	A symbol table for use in ladder programming can be automatically created.
	Changing fonts	The font displayed by the CX-Programmer is changed.

Menu Commands

The following menu commands can be used on the CX-Programmer.

Menu command		Keyboard shortcut	Description	
File	Create the Symbol Table		A symbol table for use in ladder programming can be automatically created.	
	Print Preview		The results of printing is checked on the computer monitor before printing.	
	Print		[Ctrl] + [P] Prints PCU data.	
	Exit		Saves the edited PCU data in the project file and exits the CX-Programmer.	
Edit	Undo		Undoes an edit. This command is enabled for common parameters, axis parameters, and memory operation parameters.	
	Redo		Redoes an edit that was undone. This command is enabled for editing common parameters, axis parameters, and memory operation parameters.	
	Copy		[Ctrl] + [C] Copies the selected data. This command is enabled for editing common parameters, axis parameters, memory operation parameters, and memory operation data.	
	Paste		[Ctrl] + [V] Pastes data that was copied. This command is enabled for editing common parameters, axis parameters, memory operation parameters, and memory operation data.	
	Delete		[Delete] Initializes the selected data.	
	Parameters	Common parameters		Displays the Common Parameter Edit Dialog Box.
		Axis Parameters		Displays the Axis Parameter Edit Dialog Box.
		Memory Operation Parameters		Displays the Memory Operation Parameter Edit Dialog Box.
	Memory Operation	Sequence Data	Task 1	Displays the Task 1 Memory Operation Data Edit Dialog Box.
			Task 2	Displays the Task 2 Memory Operation Data Edit Dialog Box.
			Task 3	Displays the Task 3 Memory Operation Data Edit Dialog Box.
			Task 4	Displays the Task 4 Memory Operation Data Edit Dialog Box.
Condition Data		Displays the Memory Operation Condition Data Edit Dialog Box.		
Initialize			Initializes the data in the CX-Programmer.	

Menu command		Keyboard shortcut	Description	
NC Unit	Related Parameter Settings	Origin Search Settings	Sets the parameters for origin searches in an easy-to-understand interface.	
		Synchronized Control Parameters	Sets parameters associated with the Synchronous Data Link.	
	Memory Operation Preview			Allows you to confirm the suitability of the data set in a memory operation table before transferring the data to the actual system.
	Transfer [PC to NC]		[Ctrl] + [T]	Transfers the set data to the PCU.
	Transfer [NC to PC]		[Ctrl] + [Shift] + [T]	Transfers data from the PCU.
	Compare [PC to NC]			Compares settings data on the computer with the settings in the PCU.
	Write Flash Memory			Saves data that was downloaded to the PCU in flash memory.
	Initialize Memory			Initializes all data in the PCU.
	Test Run			Performs jogging, inching, direct operation, origin searches, and wiring checks from the computer.
	Monitor			PCU status and error information is monitored.
	Monitor Memory Operation			Monitors PCU status and error information during memory operation.
	Error Log			Displays the error log of the PCU.
	Device Information			Displays the model number and unit version.
Network	Automatic Network Setup		Detects the connected slaves and automatically sets the network.	
	Verify Network		Compares the network configuration information on the computer with the actual network configuration.	
	Add Slave		[Ctrl] + [Insert]	Adds the specified slave to the network.
	Delete Slave		[Delete]	Deletes the selected slave from the network.
	Change Slave Model			Changes the model of the selected slave.
	Move Slave Up		[Ctrl] + [Up]	Reverses the positions of the selected slave and the next upstream slave in the network.
	Move Slave Down		[Ctrl] + [Down]	Reverses the positions of the selected slave and the next downstream slave in the network.
	Enable Slave			Enables the slave in the network configuration information.
	Disable Slave			Disables the slave in the network configuration information.
	Start Special Application			Starts the CX-Drive if the selected slave is supported by the CX-Drive.
	Properties			Changes the model information of the selected slave.
	Monitor Network			Monitors the slave communications status.
	Read Frame Capture File			Reserved for system (for future expansion).

	Menu command	Keyboard shortcut	Description
Tools	Options		Changes the font that is displayed when editing.
Help	Table Of Contents		Displays the contents for help.
	Topic Search		Displays the Topic Search Dialog Box.
	Version Information		Displays the version of the PCU Setting Dialog Box.

Windows and Dialog Boxes

Samples of the various windows and dialog boxes are shown below.

PCU Parameter Setting Window

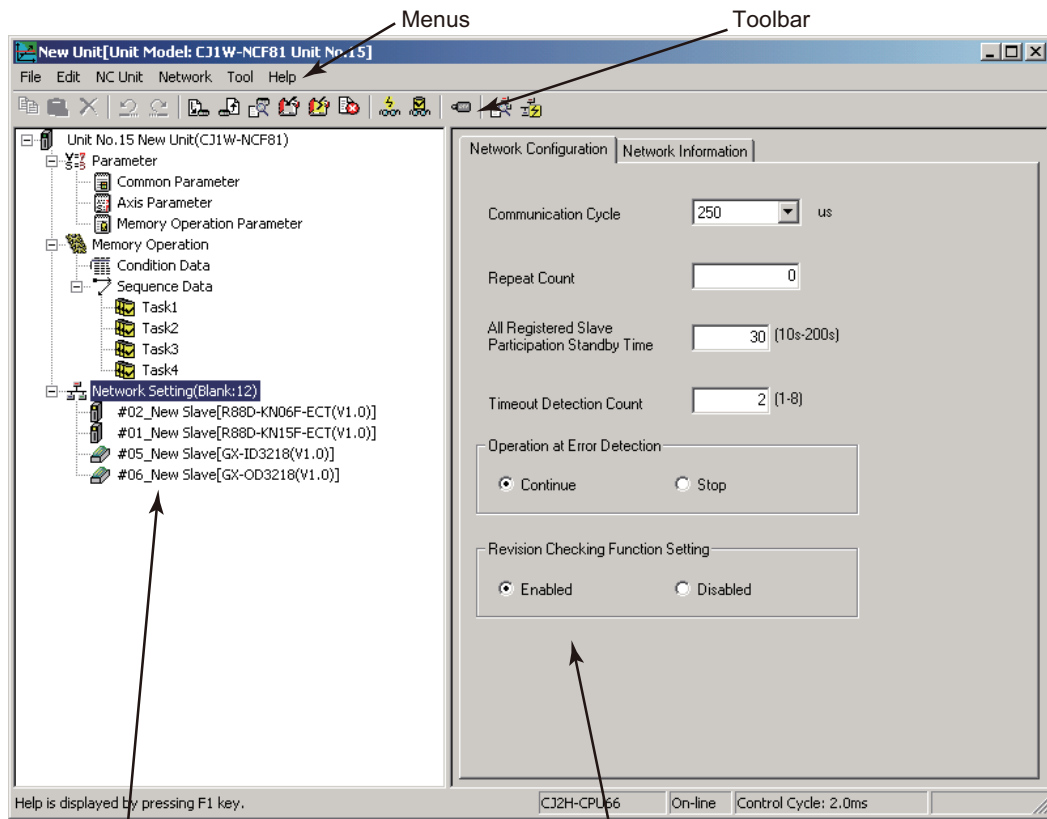

Tree View

Data Settings View

Origin Search Parameter Editing Dialog Box

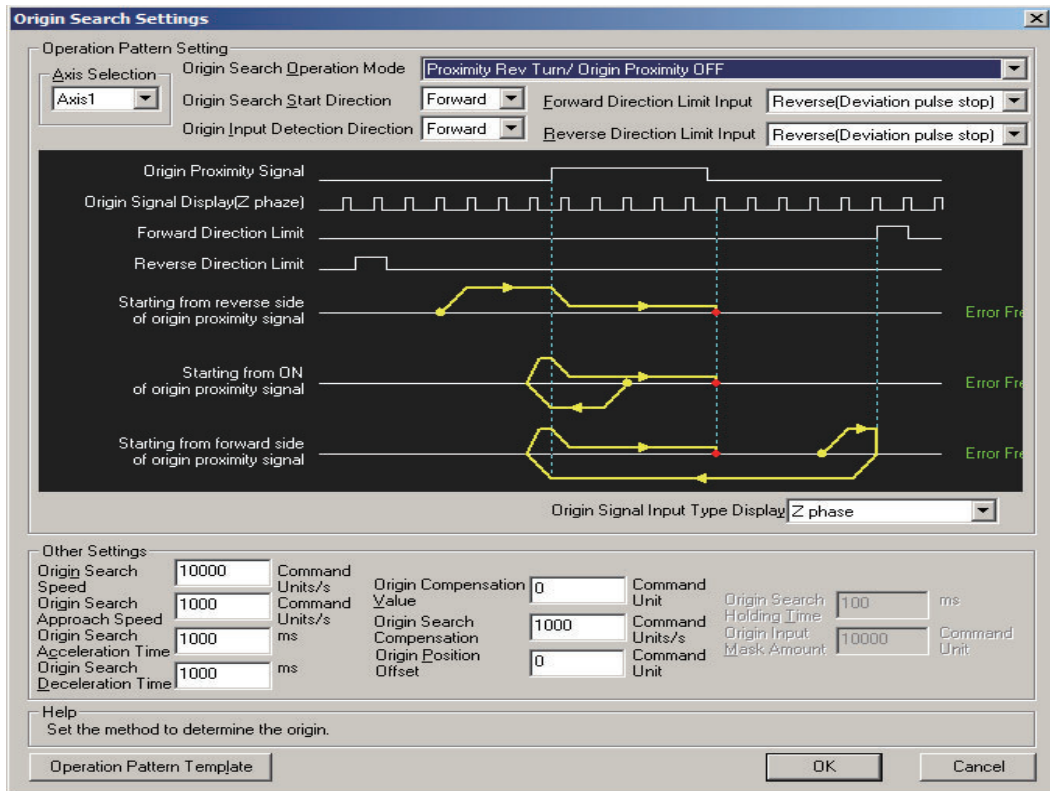

Synchronized Control Parameter Editing Dialog Box

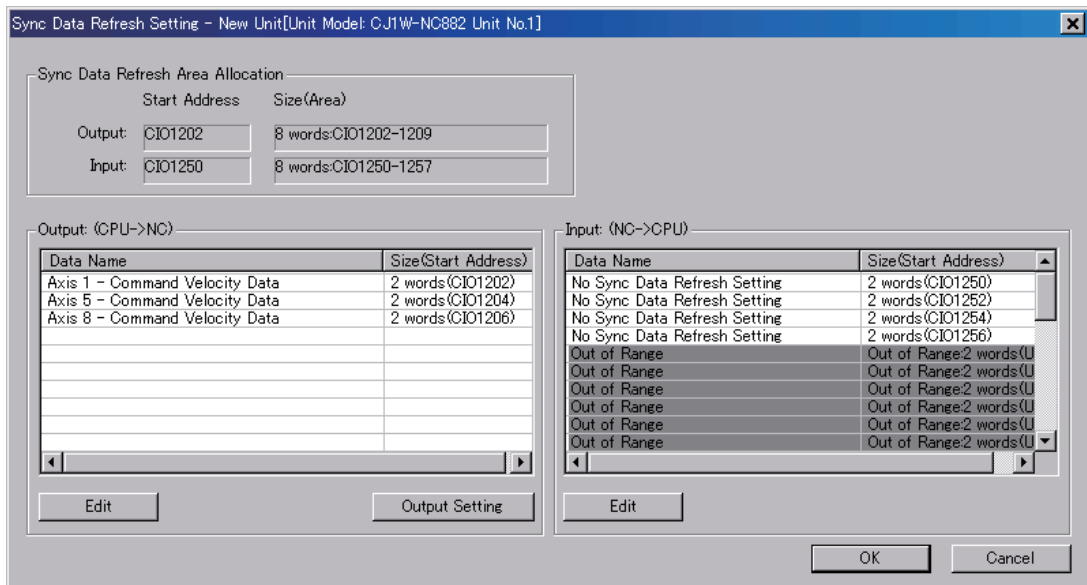

Test Run Dialog Box

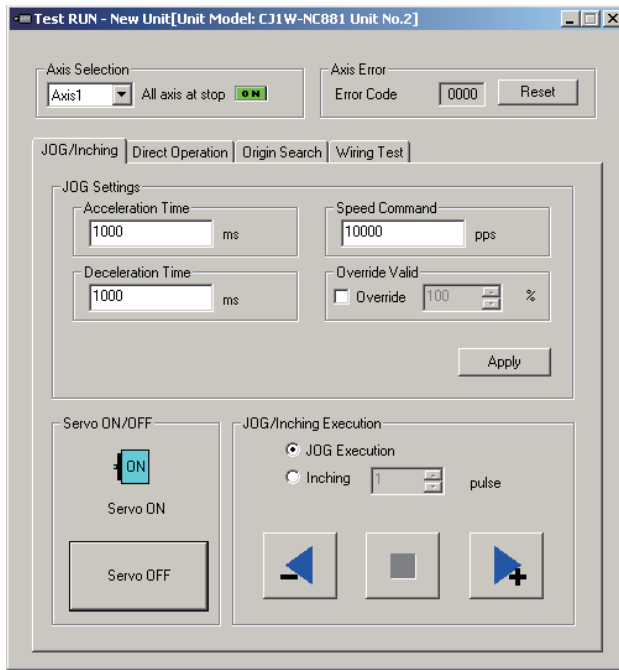

Monitor Dialog Box

Monitor Dialog Box

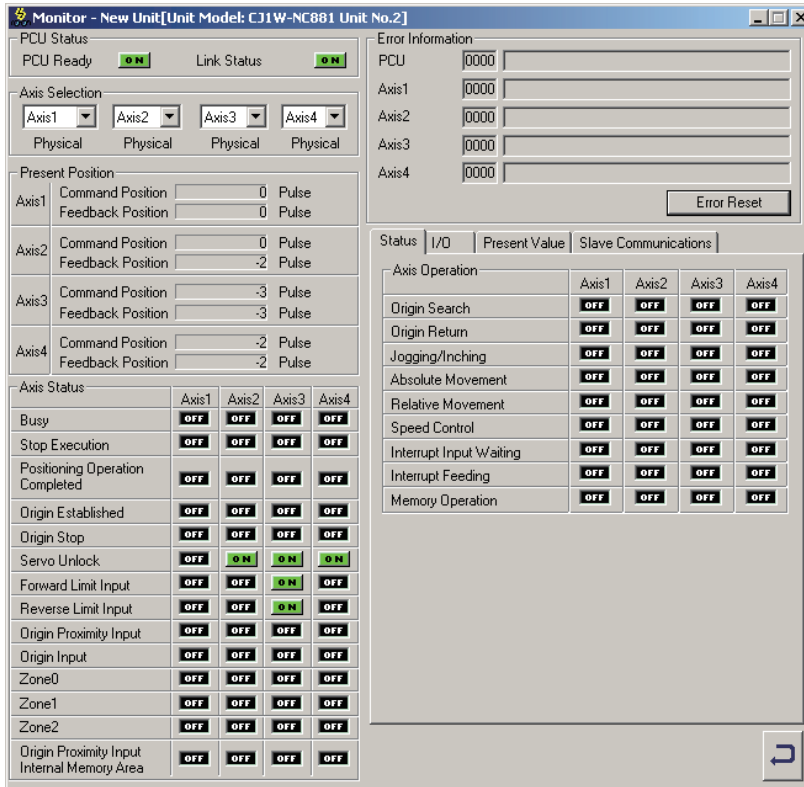

Monitor Memory Operation

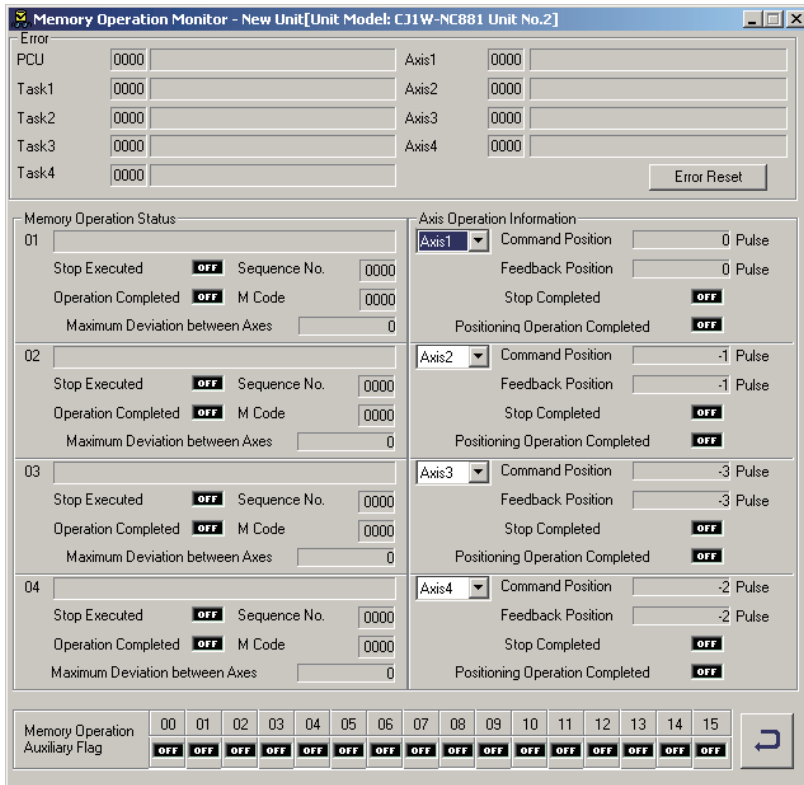

Operating Procedure

Use the following procedure from the CX-Programmer to set data for the PCU and to perform other operations.

1. Open the IO Table Window for the PLC in CX-Programmer.
2. Transfer the I/O tables from the PLC to the computer or register the PCU in the I/O tables.
3. Right-click the icon for the PCU and select Edit Special Unit Setting. Alternatively, double-click the icon for the PCU.
4. The following window will be displayed. Operations for the PCU are performed from this window.

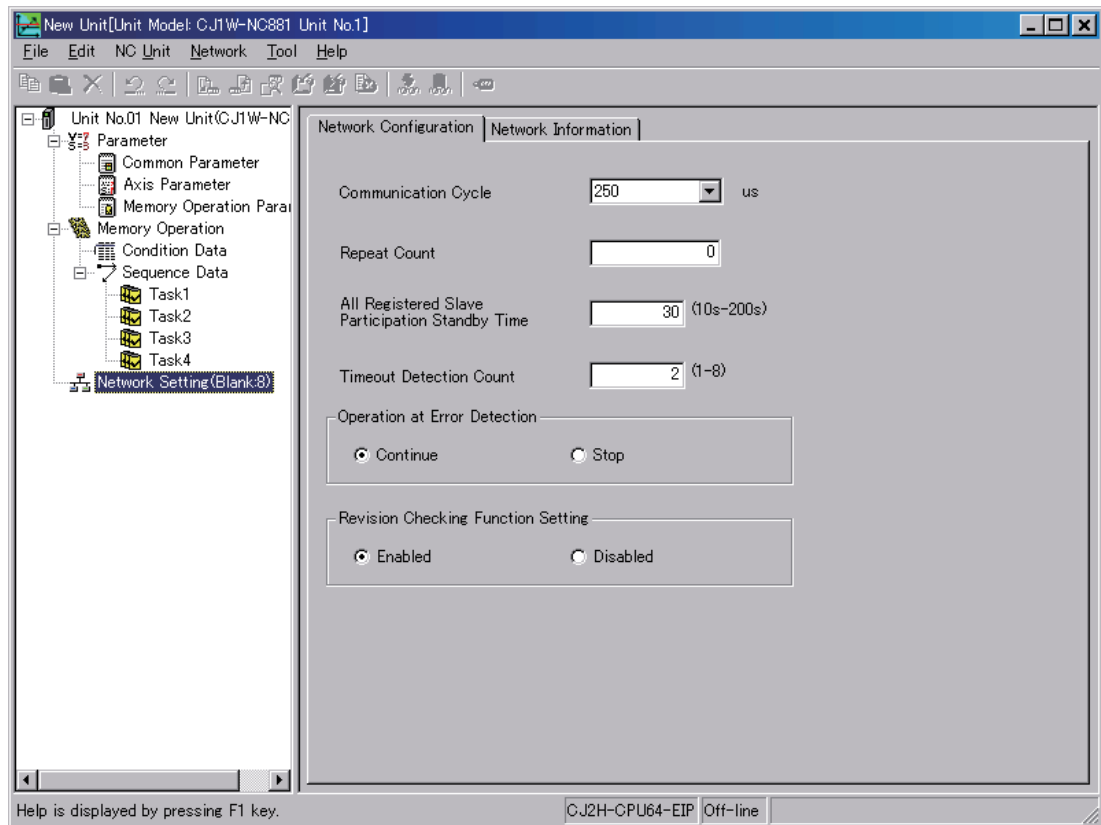

For detailed operating procedures for the CX-Programmer, refer to the *CX-Programmer Operation Manual* (Cat. No. W446).

For details on how to set data in the PCU and perform other operations, refer to the Online Help on the data setting windows for the PCU.

EtherCAT Communications

This section provides an introduction to EtherCAT and describes its communications functions.

2-1	Introduction to EtherCAT	2-1
2-2	EtherCAT Functions	2-4
2-3	Network Configuration	2-15

2-1 Introduction to EtherCAT

EtherCAT is an Ethernet-based ultra-high-speed industrial network system.

It optimizes usage of the 100-Mbps duplex communications bandwidth to enable high-speed control of motor drives, including servo drives and inverters.

It can also be used to control sensors, analog I/O, and other I/O in real-time, all using the same communications protocol.

Time information is shared between the connected slaves to synchronize control to an accuracy of $\pm 1 \mu\text{s}$.

CAN Application Protocol over EtherCAT (CoE)

The PCU exchanges data with the slaves on EtherCAT using the CAN application protocol over EtherCAT (CoE).

With CoE, the parameters and control information held by the slaves are specified according to data specifications for the object dictionary (OD).

To communicate the data between the controller/communications master and slaves, two methods are used: process data objects (PDOs), which periodically exchange data in real-time, and service data objects (SDOs), which exchange data when required.

The PCU uses PDO communications for commands to refresh data, such as data for servo-motor position control, on a fixed control cycle.

It uses SDO communications for commands to read and write data, such as for parameter transfers, at specified times.

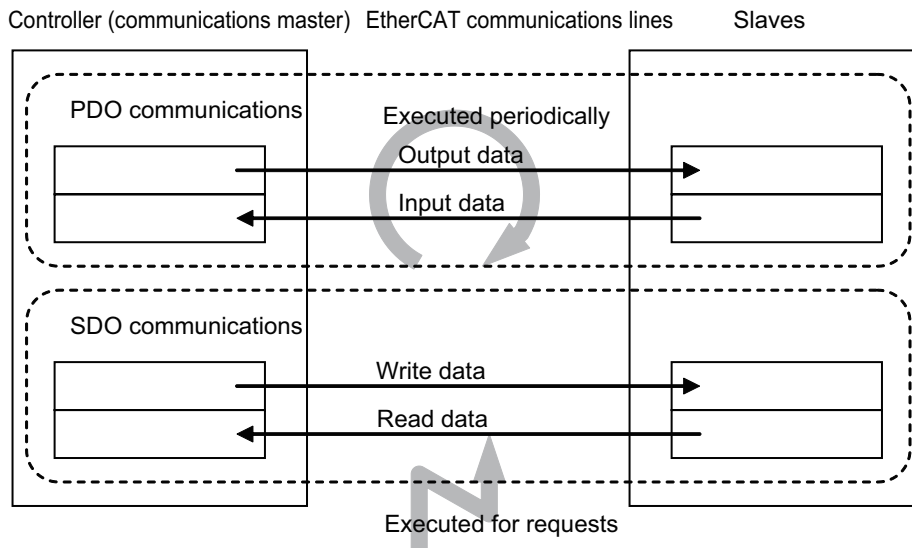

PDO communications are executed each control cycle to refresh data continuously, and SDO communications are executed between PDO communications.

Distributed Clock (DC)

EtherCAT uses distributed clocks (DCs) to ensure time synchronization in data exchange between the communications master and the slaves.

The devices connected to EtherCAT share time information and synchronize the timing of device operations based on the distributed clock in each device.

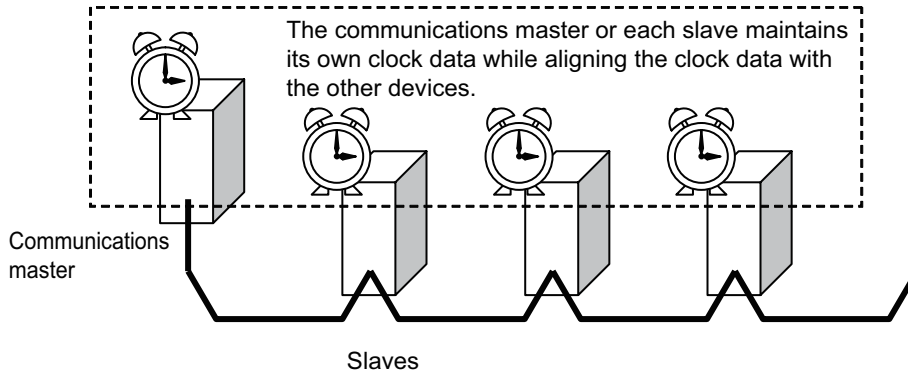

All devices perform control operations based on the distributed clocks to synchronize all devices. When the PCU is used with OMNUC G5-series Servo Drives, distributed clocks are used for synchronization.

EtherCAT Communications Settings

Setting information for EtherCAT is supplied as EtherCAT slave information (ESI).

With EtherCAT, the network connections information and definitions in the ESI on connected slaves is used to define the network configuration and communications parameters.

Configuration software for setting networks can be used to create the communications setting information in the ESI.

The communications network can be configured by transferring communications settings to the PCU or other communications master.

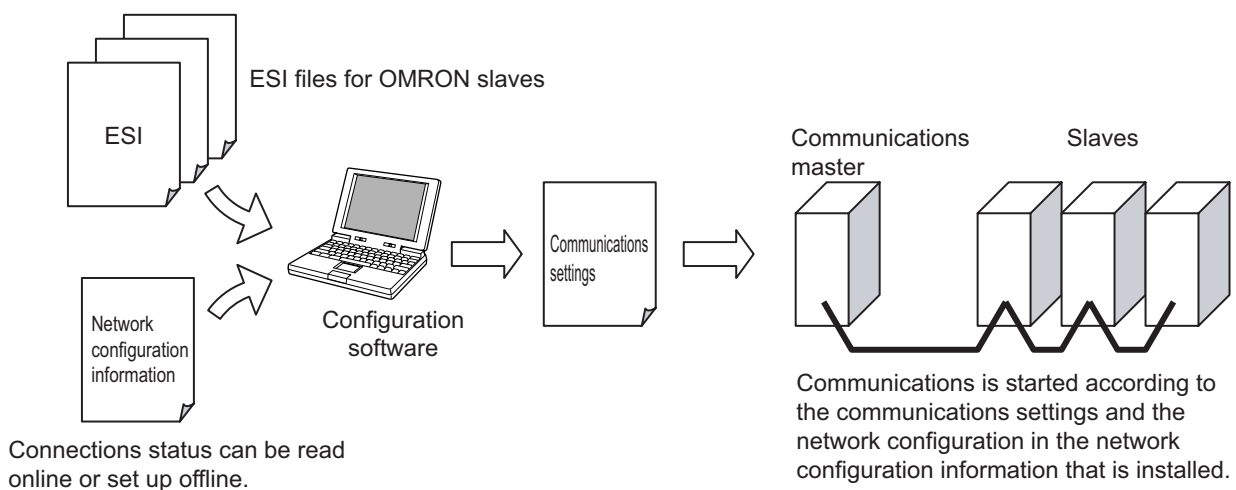

EtherCAT Communications Control States

EtherCAT communications provides the following four control states.

EtherCAT communications is controlled while automatically switching between these states while the communications master and slaves start, perform normal operation, experience errors, etc.

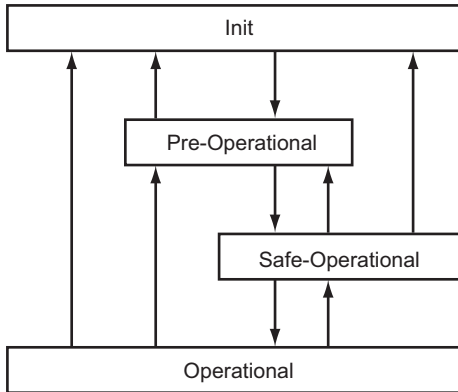

State	SDO communications	PDO communications	Description
Init	Not possible	Not possible	Devices are initialized in this state. This state exists when the devices are being initialized, e.g., immediately after power is turned ON.
Pre-Operational	Possible	Not possible	Only SDO communications are possible in this state. This state is entered after initialization has been completed. It is used to initialize network settings.
Safe-Operational	Possible	Only inputs are possible.	This is a transitional state used to move to Operational state. First Safe-Operational state is entered. Once the current input data has been obtained, Operational state is entered to perform valid outputs.
Operational	Possible	Possible	Normal device operation is performed in this state. I/O is refreshed using PDO communications and devices can be controlled through EtherCAT communications.

The PCU automatically switches between these states. There is normally no need for the user to be aware of them.

You can determine the current communications state from the indicators on the front of the PCU or from the communications status given in the PCU Control Input Memory Area.

For information on the indicators, refer to *Indicators* on page 3-1. For information on the PCU Control Input Memory Area, refer to *PCU Control Memory Input Area* on page 6-80.

2-2 EtherCAT Functions

The PCU provides the following two EtherCAT communications functions.

Function	Description
Communications for Servo Drive control (for G5-series Servo Drives only)	When OMNUC G5-series Servo Drives are connected, a monitor interface is provided in an area of memory allocated in the CPU Unit. The allocated area of memory is similar to the one supported by the PCUs with Pulse Outputs (CJ1W-NC□□4).
Remote I/O master function	When compatible devices other than OMNUC G5-series Servo Drives are connected, the remote I/O of the connected slaves can be updated during each I/O refresh of the PLC. PLC memory is directly allocated to the I/O of the connected slaves.

The PCU maintains the following two types of information to achieve these EtherCAT communications functions. The first is the communications setting information, which defines the network configuration and individual communications settings.

The second is the process data table. The process data table contains settings that map the relations between information inside the PCU and the area of memory allocated in the CPU Unit with the I/O data (i.e., PDOs) that flows on EtherCAT.

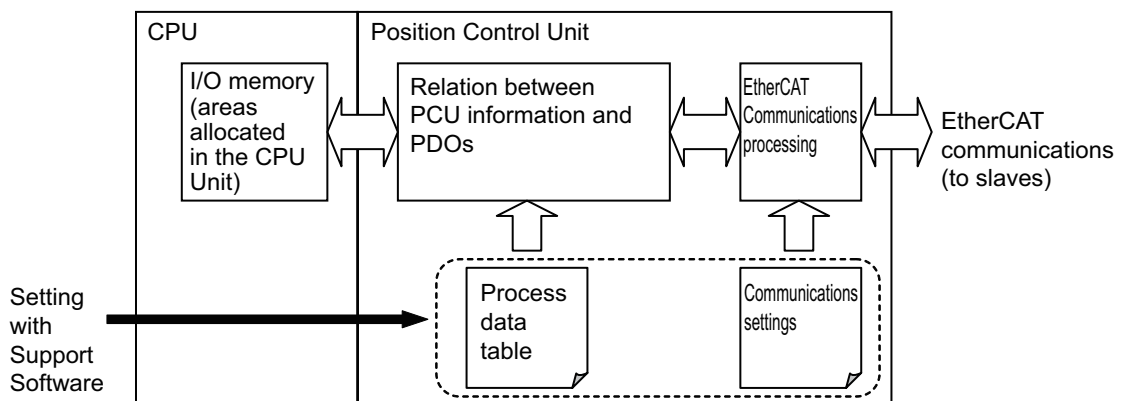

The process data table is provided to devices that are supported by the PCU as unique PCU setting information. The information settings in both the process data table and communications setting information are made in the PCU from the Support Software.



Precautions for Correct Use

There are restrictions in the EtherCAT slaves that can be connected to the PCU.

If a slave that is not supported is connected, it will not be possible to set the network configuration of the PCU or to establish EtherCAT communications.

Ask your OMRON representative for information on the slaves that are supported by the PCU.

Relation between Allocated Areas of Memory

The word allocations that are used as the user interface to control the PCU from the user program are outlined in the following table for OMNUC G5-series Servo Drive connections and for other connections.

User interface	I/O	Allocated words	OMNUC G5-series Servo Drive connections	Connections other than OMNUC G5-series Servo Drives
PCU Control Memory Areas	IN/OUT	Words in the CPU Bus Unit Area	PCU control outputs	
			Communications control outputs	
			PCU control inputs	
			Communications control inputs	
Axis Operation Memory Areas (Remote I/O Memory Areas)	OUT	2 words for each slave starting from word A	Manual Operation Command Memory Area	–
	OUT	12 words for each slave starting from word B	Direct Operation Command Memory Area	Output Memory Area
	IN	13 words for each slave starting from word C	Axis Status Memory Area	Input Memory Area
	IN	16 words for each slave starting from word F	Expanded Monitor Memory Area	Input Memory Area
Memory Operation Memory Areas	OUT	3 words for each task starting from word D	Memory Operation Command Memory Area	–
	IN	6 words for each task starting from word E	Memory Operation Status Memory Area	–
Remote I/O Memory Areas	OUT	Variable length starting from word G	–	Output Memory Area
	IN	Variable length starting from word H	–	Input Memory Area
	IN	20 words starting from word J	–	Communications Status Area

Note: A to H and J are the first words in the areas. These are set in the common parameters in the PCU.

PCU Control Memory Area

These words are allocated to control I/O for the entire Unit and to I/O related to controlling communications. These words are not specific to any one slave, i.e., they affect overall operation. They are allocated in the CPU Bus Unit Area according to the unit number setting of the PCU.

Axis Operation Memory Areas (Remote I/O Memory Areas)

I/O words are allocated to manipulate each OMNUC G5-series Servo Drive or other slave. Operation Memory Areas are allocated to slaves with node addresses 1 to 16.

When an OMNUC G5-series Servo Drive is connected, bits in these words are allocated as command bits and status flags, just as with the previous models of PCUs. Each axis has separate command bits and status flags.

When a device other than an OMNUC G5-series Servo Drive is connected, the Direct Operation Command Memory Area (12 output words/axis), Axis Status Memory Area (13 input words/axis), and Expanded Monitor Memory Area (16 words/axis) in the Axis Operation Memory Areas are used as output and input memory areas.

When slaves other than OMNUC G5-series Servo Drives are connected, the Manual Operation Command Area is not used.

With this PCU, the axis numbers in the allocated words are the same as the node address of the slaves.

Example: Node Address 3 = Axis 3

The node address setting range is determined by the number of controlled axes supported by the PCU.

Model	Number of controlled axes	Node address setting range
CJ1W-NC281	2 axes	1 to 2
CJ1W-NC481	4 axes	1 to 4
CJ1W-NC881	8 axes	1 to 8
CJ1W-NCF81	16 axes	1 to 16
CJ1W-NC482	4 axes	1 to 4
	64 nodes for remote I/O	17 to 80
CJ1W-NC882	8 axes	1 to 8
	64 nodes for remote I/O	17 to 80
CJ1W-NCF82	16 axes	1 to 16
	64 nodes for remote I/O	17 to 80



Precautions for Correct Use

If an out-of-range node address is set, a network configuration verification error will occur.

Memory Operation Memory Areas

I/O words are allocated to perform memory operation of the PCU.

These I/O words are used to control memory operation for OMNUC G5-series Servo Drives. They do not directly affect other types of slaves.

Remote I/O Memory Areas

Remote I/O Memory Areas are allocated only when using CJ1W-NC482/NC882 F82 PCUs. Node addresses 17 to 80 are allocated to the slaves.

There are three Remote I/O Memory Areas.

Area name	Description
Remote I/O Output Memory Area ^{*1*2}	Output bits are allocated to the remote I/O. In the default settings, bits are allocated starting from CIO 3800.
Remote I/O Input Memory Area ^{*1*2}	Input bits are allocated to the remote I/O. In the default settings, bits are allocated starting from CIO 3900.
Remote I/O Communications Status Area ^{*2}	This area is allocated to the communications status of slaves with node addresses 17 to 80. In the default settings, it is allocated starting from CIO 3980.

*1. Up to 640 words can be allocated, depending on the slaves that are used.

*2. The allocated first word can be changed with the common parameters. For details, refer to *Operation Memory Area Allocation Settings* on page 6-17.



Precautions for Correct Use

- ♦ The actual number of words that is allocated as remote I/O memory for slave inputs and outputs depends on the allocation method. Either fixed allocations or free allocations can be used. For details on the allocation method, refer to *Allocations of Remote I/O Memory Areas* on page 6-5.
- ♦ With fixed allocations, one word is allocated per node.
If slaves that require more than two words are registered, it may not be possible to register up to 64 nodes. If this is the case, free allocations can be selected to avoid the problem.
- ♦ Use the CX-Programmer to check the status of fixed allocations and to select free allocations. Refer to *Relation between Allocated Areas of Memory* on page 6-3 for details on fixed allocations and free allocations, as well as how to check and set the allocations.

Relationship between Axes and Slaves

The Axis Type axis parameter in the PCU specifies axis usage. The parameter, however, does not affect the network configuration.

The network configuration information is based on the slaves that are actually connected to the network or on the network configuration that is created.

Setting Nodes 1 to 16

Axis type ^{*1}	Network configuration information	Slave enabled/disabled ^{*2}	Connection status	Description
Physical axis	G5-series Servo Drive slaves are registered.	Enabled	Connected	The axis can be controlled as a physical axis.
			Not connected	If a network configuration verification error occurs, or if no slaves are connected to the PCU, a link OFF error will occur. In this case, the devices cannot be controlled as physical axes.
		Disabled ^{*3}	–	The axis will operate as a virtual axis. Regardless of the connection status, communications errors will not occur. Slave communications status, such as the Registered Slave Table and Added Slave Table, will always be OFF.
	Slaves other than G5-series Servo Drives are registered.	Enabled	Connected	The device can be controlled as an actual remote I/O slave.
			Not connected	If a network configuration verification error occurs, or if no slaves are connected to the PCU, a link OFF error will occur. In this case, the devices cannot be controlled as actual I/O slaves.
		Disabled ^{*3}	–	Words in the I/O memory area are reserved as an unused area. Regardless of the connection status, communications errors will not occur. Slave communications status, such as the Registered Slave Table and Added Slave Table, will always be OFF.
Slave are not registered.	–	Connected	A network configuration verification error will occur.	
		Not connected	The axis will operate as a virtual axis. Regardless of the connection status, communications errors will not occur. Slave communications status, such as the Registered Slave Table and Added Slave Table, will always be OFF.	
Unused axis	Slave are registered.	–	–	Cannot be set. (Checked by the configuration tool.)
	Slave are not registered.	–	–	The axis will not be used.

*1. For details on axis types, refer to *Axis Type Setting* on page 6-32.

*2. For information on the settings to enable and disable slaves, refer to *Network Configuration Display* on page 2-19.

*3. This setting cannot be used for a PCU with unit version 1.0.A parameter setting error will occur.

Setting Nodes 17 to 80 (CJ1W-NC482/882/F82 PCUs Only)

Network configuration information	Slave enabled/disabled*1	Connection status	Description
Slave are registered.	Enabled	Connected	The device can be controlled as an actual remote I/O slave.
		Not connected	If a network configuration verification error occurs, or if no slaves are connected to the PCU, a link OFF error will occur. In this case, the devices cannot be controlled as actual I/O slaves.
	Disabled	—	Words in the I/O memory area are reserved as an unused area. Regardless of the connection status, communications errors will not occur. Slave communications status, such as the Registered Slave Table and Added Slave Table, will always be OFF.
Slave are not registered.	—	Connected	A network configuration verification error will occur.
		Not connected	—

*1. For information on the settings to enable and disable slaves, refer to *Network Configuration Display* on page 2-19.

PCU Data Exchange

The PCU performs internal processing in synchronization with EtherCAT communications processing. The control cycle will be an integral multiple of the EtherCAT communications cycle. A visualization of PCU data exchange, including the CPU Unit and slaves, is shown in the following figure.

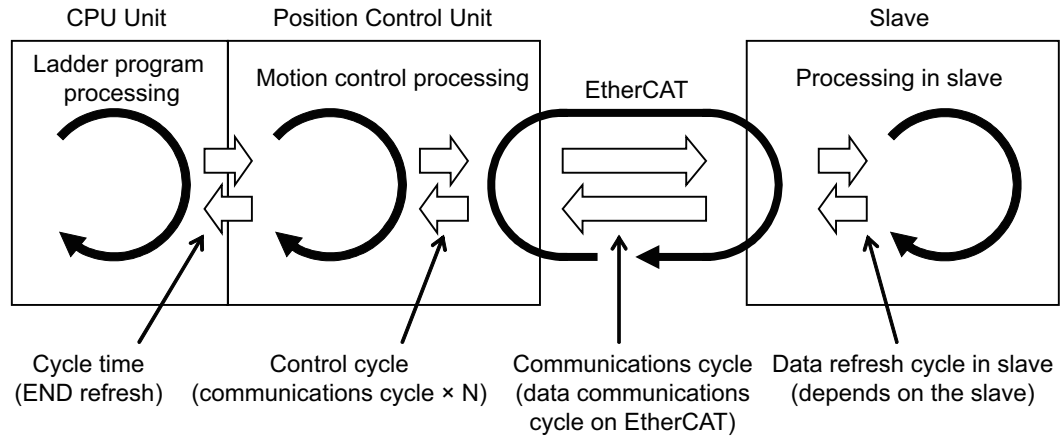

Precautions for Correct Use

The setting ranges of the communications cycle time and control cycle depend on the number of slaves that are connected. For details, refer to *Relation between the Number of Slaves and the Communications and Control Cycles* on page 6-12.

Communications Status

The PCU uses the following status information to show the status of EtherCAT communications. The status information is separated into status for overall EtherCAT communications and status tables for individual slave status. For details on status information, refer to *PCU Control Memory Input Area* on page 6-80 and *Remote I/O Communications Status Memory Area* on page 6-131.

Overall EtherCAT Communications Status

The following status information gives the overall status of EtherCAT communications.

This status information can be used as the overall EtherCAT communications status to align timing between communications and device control and for interlocks.

Status name	Word/bit	Description
EtherCAT Detection Processing Flag	PCU Control Input Memory Area, n+12 bit 09	This flag indicates when connection processing is being performed for EtherCAT communications after power to the PCU is turned ON, after the PCU is restarted, after PCU setup is completed, or after leaving a Support Software-controlled mode.
Communications Status	n+18	The Link Status Flag in bit 13 shows the link status (i.e., communications line connection status) of EtherCAT communications. The All Slave Process Data Communications Flag in bit 14 shows when normal communications have been started with all connected slaves.
Communications Error Flags	n+19	These flags indicate ORs of the factors causing errors, such as errors in the network configuration, verification errors, and other overall setting errors, as well as errors that occur in individual slaves that are connected. The Error Slave Table can be used to identify the slaves where errors have occurred.

Status for Individual Slaves Connected to EtherCAT

The following status information shows the status of individual slaves connected to EtherCAT. Each type of status is provided as a one-word table, where bit 00 corresponds to node 1, bit 01 corresponds to node 2, bit 02 corresponds to node 3, in order until the last node.

As opposed to the overall EtherCAT communications status, the following status can be used to identify the status of individual slaves.

Status name	Word/bit		Description
	Node addresses 1 to 16 ^{*1}	Node addresses 17 to 80 ^{*2}	
Registered Slave Table	n+20	J to J+3	This table shows the slaves that are registered in the network configuration information.
Network Participation Table	n+21	J+4 to J+7	This table shows the status of slaves participating in the network
Slave Message Communications Enabled Table	n+22	J+8 to J+11	This table shows the slaves for which message communications is possible. If one of these flags is ON, the corresponding slave is in a status where SDO communications is possible (Pre-Operational, Safe-Operational, or Operational status).
Normal Slave Table	n+23	J+12 to J+15	This table shows the slaves that are performing process data communications. If one of these flags is ON, the corresponding slave is executing PDO communications (Operational status). When these flags are ON, operation using the allocated operation memory areas is possible for the corresponding slaves. This flags can thus be used as interlock conditions for EtherCAT communications in ladder programming for slave operation.
Error Slave Table	n+24	J+16 to J+19	This table shows the slaves for which communications errors have occurred. You can check to see if any of these flags is ON to see if errors have occurred in any slaves.

*1. Words for node addresses 1 to 16 are allocated in the CPU Bus Unit Area.

*2. Words for node addresses 17 to 80 are allocated in the Remote I/O Communications Status Memory Area. The following table lists the allocations when you set the First Word of Remote I/O Communications Status Memory Area parameter to word "J."

Timing Chart

The following chart shows an example of the timing of communications status. The behavior of the flags depends on the cause of any errors that occur.

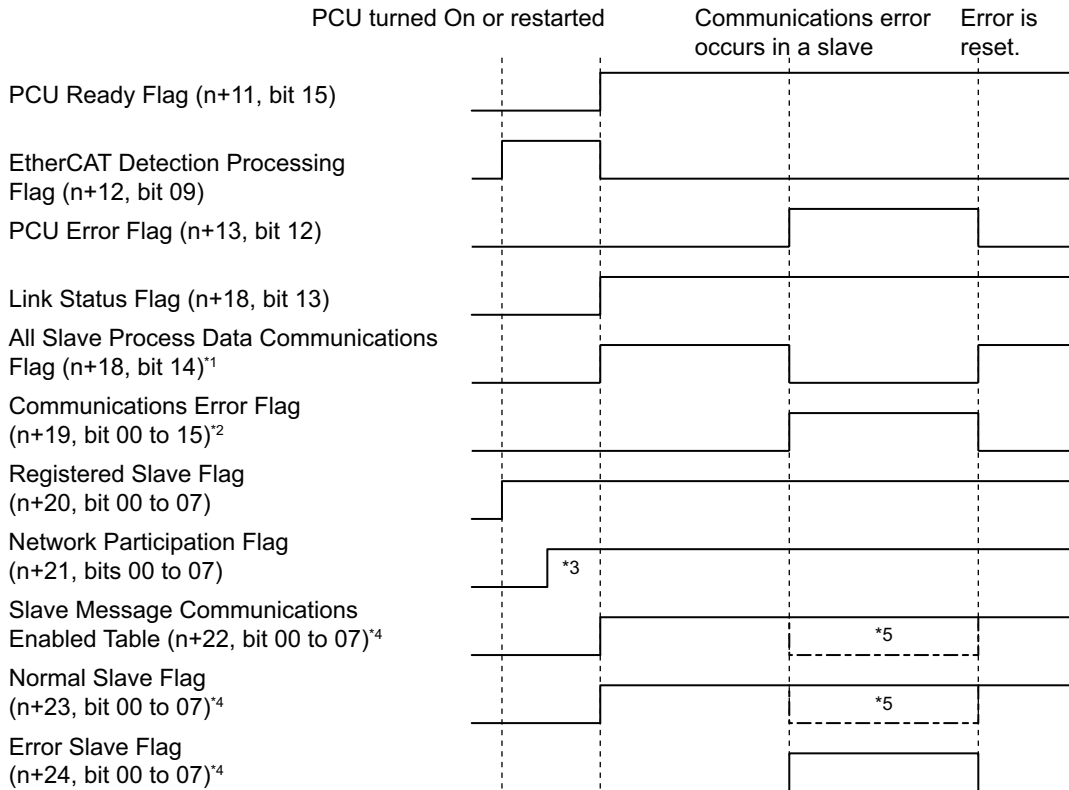

- *1 Indicates when all process data communications are being performed for the registered slave.
- *2 Indicates the cause of the error in the slave.
- *3 The flag corresponding to the slave turns ON when the slave is detected.
- *4 The flag corresponding to the slave turns ON and OFF.
- *5 Whether message communications and process data communications are possible depends on the cause of the error.

The PCU waits for registered slaves to join the network from when the power supply is turned ON, the PCU is restarted, or the PCU setup status is cleared, until the amount of time specified for the All Registered Slave Participation Standby Time has passed.

The All Registered Slave Participation Standby Time parameter is in the Network Settings. It is possible to see the participation of registered slaves by checking whether flags in the Network Participation Table are ON. When all registered slaves have joined the network and normal communications has been started, the flags corresponding to PCU Ready, Slave Message Communications Enabled Table, and Normal Slave Table turn ON. At this point, operation using allocated bits also is enabled.

If the All Registered Slave Participation Standby Time elapses without detecting a registered slave, the PCU generates a Network Configuration Error or a Network Configuration Verification Error. Operation when an error is detected follows the setting of the parameter shown below.

Operation at Error Detection	Operation performed when the All Registered Slave Participation Standby Time has elapsed
Continue operation	Only registered slaves that have correctly joined the network will become operational and start EtherCAT communications.
Stop	Message communications are enabled (on standby in Pre-Operational status) for registered slaves that have correctly joined the network. Process data communications will not be started with any slaves.



Reference

- If a Network Configuration Error or Network Configuration Verification Error occurs, the error status can be cleared by turning ON the Error Reset Bit in the PCU Control Command Bits. After the error is reset, the process to establish communications is started.
- A user program can be created to execute the Error Reset Bit after a Network Configuration Error or Network Configuration Verification Error has occurred, try to reestablish communications, and then wait for slave participation. With a user program, it is possible to wait for the slaves to join the network for as long as desired regardless of the setting of the All Registered Slave Participation Standby Time. As an example, a sample user program which tries to reestablish communications when connecting nodes with node addresses 1 and 2 is shown below. The process to reestablish communications is repeated for the duration specified for timer 0 until process data communications starts with all slaves. The unit number is 0. The registered nodes have node addresses 1 and 2.

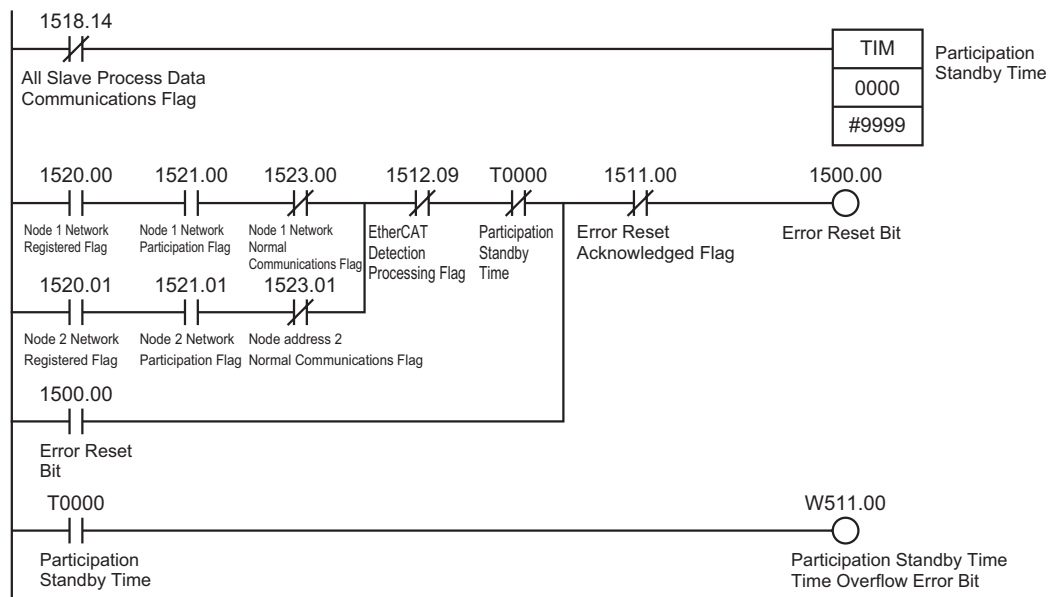

2-3 Network Configuration

This section describes how to set the network configuration.

The network can be configured with an automatic network setup method or a manual method.

EtherCAT Communications Network Configuration

The EtherCAT communications network configuration is determined by the connection position (order) in the network and the node address of the connected slaves. For this reason, it is necessary that the connection positions and node addresses set in the network configuration information in the PCU match the actual network configuration.

If the network configuration information set in the PCU does not match the actual network configuration that is connected, one of the following errors will be detected.

◆Network Configuration Error

The maximum number of nodes was exceeded, the topology of the connected network does not meet specifications, or network connection wiring error.

◆Network Configuration Verification Error

No slave is connected to a registered node address, or a slave that is not registered within the maximum number of nodes is connected.

For example, if the following network configuration is set in the CJ1W-NC881, the network configuration verification will result as shown below depending on the actual connection status.

Network Settings

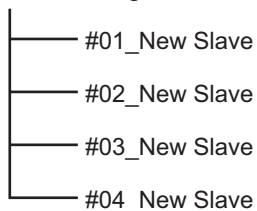

Actual Connections

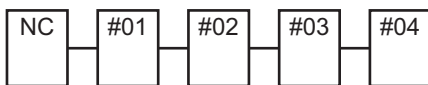

The network configurations match. Normal operation can resume.

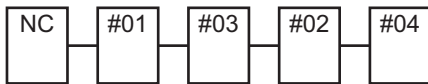

The connection positions of nodes with node addresses 2 and 3 do not match.

A network configuration verification error will occur.

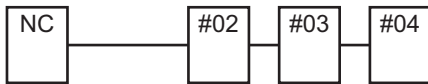

The connection positions of nodes with node addresses 2 to 4 do not match because node address 1 is missing.



Node 9 is connected, which is outside the range of the maximum number of node addresses.

A network configuration error will occur.

**Precautions for Correct Use**

OMNUC G5-series Servo Drives can be set to specific node addresses by using the rotary switches on the front panels. If the rotary switches are set to 00, the node address will conform to the network configuration set in the PCU.

If the rotary switches are set to 00 for all connected Servo Drives, network configuration errors will not occur even if the Servo Drive's connection position is changed. When allocating specific Servo Drives for individual control targets, set the Servo Drive node addresses with the rotary switches so that network configuration can be verified.

Number of Remote I/O Connections

The PCU has up to 640 bytes of memory for PDO communications inputs and 640 bytes for outputs.

The same PDO communications memory is used for both Servo Drives and I/O slaves.

The number of slaves that can be connected to the CJ1W-NC482/ 882/ F82 is determined by the maximum memory size for PDO communications.

This means that the numbers of slaves that can be connected according to the number of OMNUC G5-series Servo Drives that is connected (number of axes used) are as given in the following table.

Number of Servo Drive axes	Size used by Servo Drive axes (bytes) ^{*1}	Remaining PDO communications memory size (bytes)		Number of slaves that can be connected according to slave I/O size (guidelines)			
		IN	OUT	8 bytes of I/O (4 input and 4 output bytes)	16 bytes of I/O i(8 input and 8 output bytes)	32 bytes of I/O i(16 input and 16 output bytes)	64 bytes of I/O i(32 input and 32 output bytes)
0 axis	0	640	640	64	64	40	20
1 axis	29	611	611	64	64	38	19
2 axes	58	582	582	64	64	36	18
4 axes	116	524	524	64	64	32	16
8 axes	232	408	408	64	51	25	12
16 axes	464	176	176	64	22	11	5

*1. The OMNUC G5-series Servo Drives also use IN and OUT bytes. The factory default size for PDO communications is 29 bytes.

**Precautions for Correct Use**

For slaves that have both input and output data, the number of bytes for the larger of either the input or output memory size is used for PDO communications in the PCU.

For example, if you connect an I/O slave with 32 input bytes and 16 output bytes to a PCU, 32 bytes of memory will be used for inputs and 32 bytes will be used for outputs.

Make sure to check how much memory is used for PDO communications when connecting slaves that have both inputs and outputs to a PCU.

Selecting PDO Mappings When Using the PCU in Conjunction with a G5-series Servo Drive

When used in conjunction with an OMNUC G5-series Servo Drive (version 2.0 or later), the CJ1W-NC□81/-NC□82 (unit version 1.3 or later) allows you to extend its control functions.

You can extend the control functions of the PCU by selecting a set of PDO mappings that support the motion functions you want to use.

The table below shows which motion functions of the Servo Drive are supported by each of available PDO map sets:

Motion function	PDO map set (1) ^{*1}	PDO map set (2) ^{*2}	PDO map set (3) ^{*3}	PDO map set (4) ^{*3}
	RxPDO/TxPDO	RxPDO/TxPDO	RxPDO/TxPDO	RxPDO/TxPDO
	1701 hex/1B01 hex	1702 hex/1B04 hex	1704 hex/1B04 hex	170 hex/1B04 hex
Position control (CSP)	○	○	○	○
Speed control (CSV) ^{*4}	×	○	○	○
Torque control (CST) ^{*4}	×	○	○	×
Option: Torque feed-forward ^{*4}	×	×	×	○
Option: Torque limit ^{*4}	×	×	○	○
Option: Velocity limitation ^{*4}	×	○	○	×
Origin search	○	○	○	○
Latch probe/interrupt feeding	○	○	○	○
Torque limit data refreshing	×	×	○	○
Feedback speed monitoring	×	○	○	○

*1. If your PCU is connected with an OMNUC G5-series Servo Drive earlier than version 2.0, PDO map set (1) is selected on a fixed basis.

*2. Immediately after your PCU is added to the network configuration, PDO map set (2) is selected by default. (Factory default)

If you perform full-closed loop control, select PDO map set (1).

*3. Change the Torque Limit Switching Mode setting (3521h) for G5-series Servo Drive to 5. For details, refer to *10-4 Torque Limits* on page 10-19.

*4. This function is part of the Synchronous Data Link function and therefore not available with the CJ1W-NC□81.

Configuration Using the Automatic Network Setup

When the network is set up automatically, the actual configuration of the network is read and the configuration information that is read is used as the basis for automatically setting up the network. After the automatic network setup has been performed, jogging, inching, direct operation, origin searches, and wiring checks can be performed in Test Run Mode.

Execution Method

There are two ways that can be used for automatic network setup.

- Select Network Auto Setup from the Network Menu.
- Start the Support Software while connected online. If there are no network settings in the PCU, the network will be set up automatically.

Flowchart for Automatic Network Setup

A flowchart for automatically setting up the network is given below.

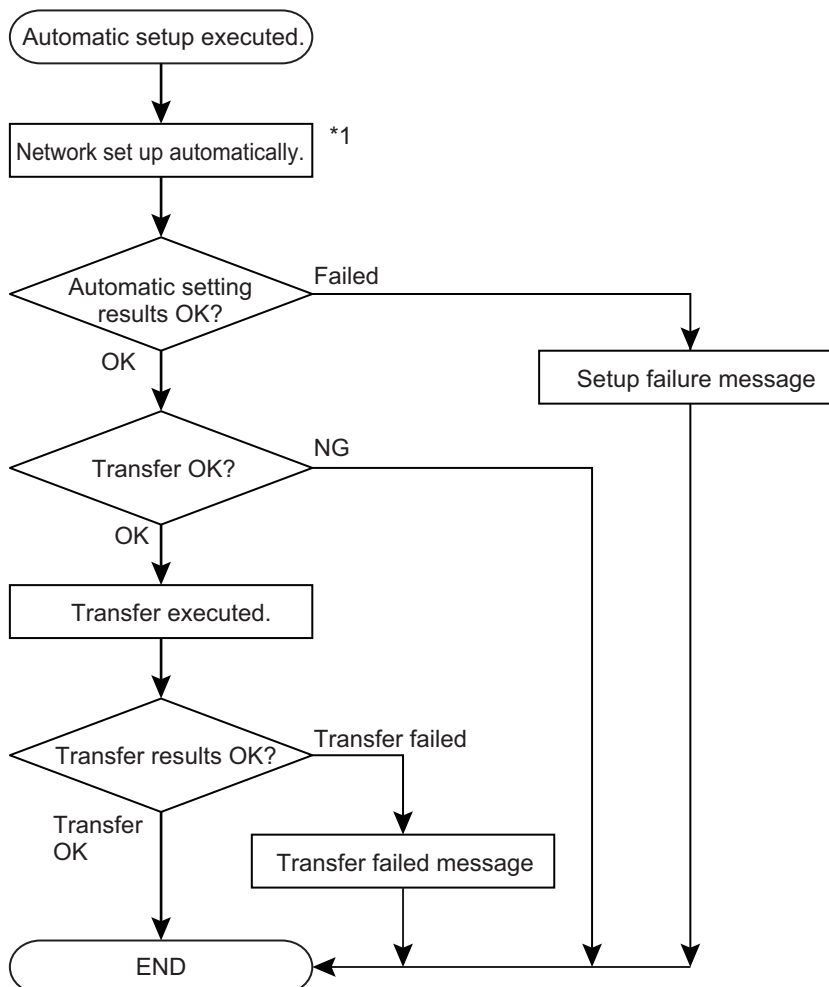

*1 Network configurations that have been created using automatic network setup can be corrected manually.



Manual Configuration

The network can be configured manually by adding and deleting slaves and changing slave models. First we will describe the network configuration display.

Network Configuration Display

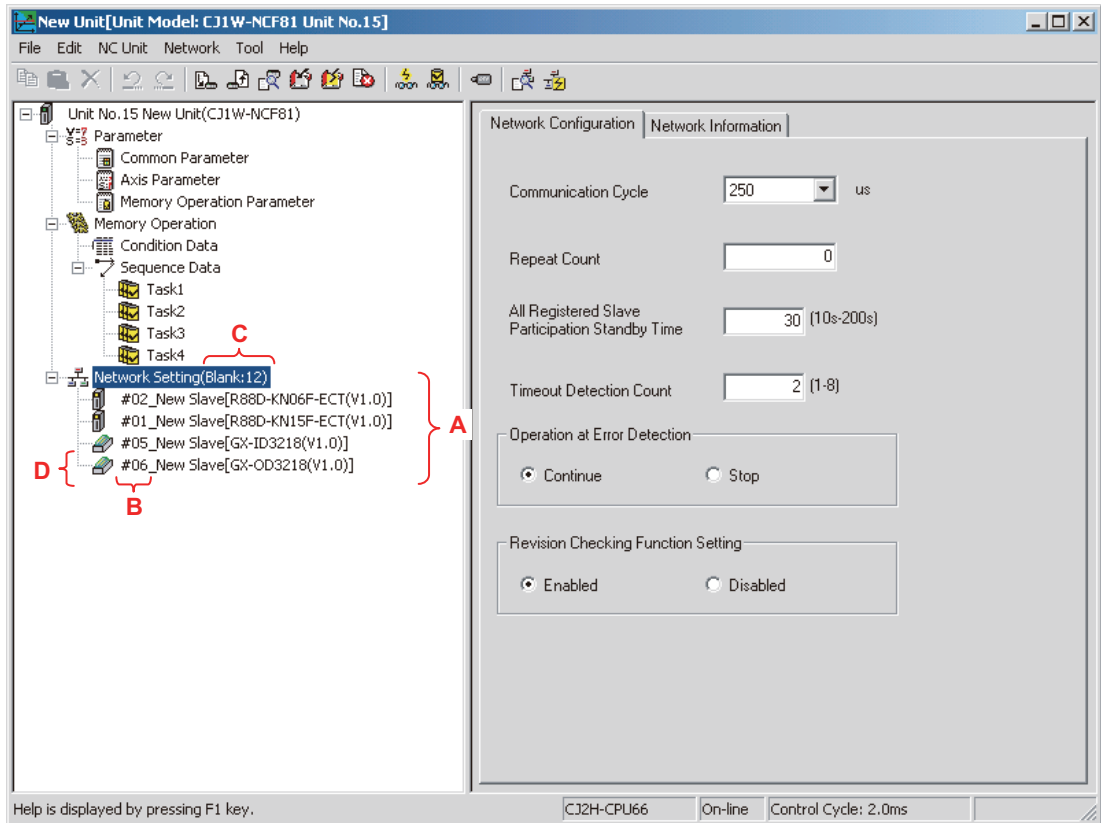
The network configuration is displayed as shown below in a tree view of the slaves connected to the EtherCAT network with the PCU as the master.



Symbol	Name	Description
A	Order of display	The slaves that are connected to the EtherCAT network are displayed in order with the slave that is closed to the PCU on top.
B	Node address	The node address of the connected slave is displayed. It corresponds to the control axis number in the PCU.
C	Number of unregistered slaves	The number of slaves that can still be registered in the PCU is displayed.
D	Slave enabled/disabled status	Whether the slave is enabled or disabled is indicated.  is displayed when the slave is enabled and  is displayed when it is disabled.

Adding Slaves

When you add a slave, it will be added to the end of the network.

Execution Method

There are three ways that can be used to add a slave.

- Select Add Slave from the Network Menu.
- Right-click in the network settings in the tree view and select Add Slave from the pop-up menu.
- Place the focus on a slave or the network settings in the tree view and press the Ctrl + Insert Keys.

When a slave is added, a dialog box will be displayed to select the slave.

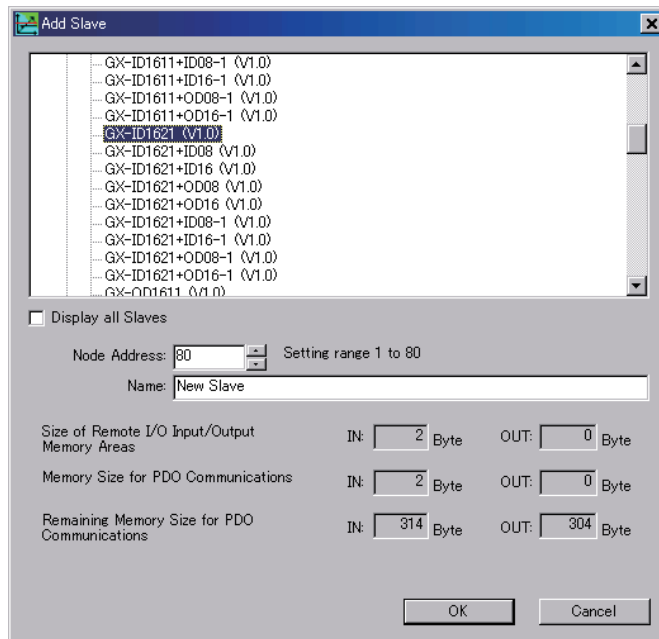

Name	Description
Node address	Specifies the node address. The recommended node address ^{*1} is displayed at startup.
Name	Displays the name of the slave. The name can be edited. If the slave name contains characters specific to a particular language, the Start Special Tool -- Start with Settings Inherited menu command cannot be used to start the CX-Drive when operating under an OS for a different language. To use saved data in different language platforms, use single-byte alphanumeric characters for the slave names.
Size of Remote I/O Input/Output Memory Areas	Displays the size of memory used for the Remote I/O Input/Output Memory Area for the selected slave.
Memory Size for PDO Communication	Displays the size of memory used for PDO communications for the selected slave.
Remaining Memory Size for PDO Communications	Displays the size of memory still available for use in PDO communications.

*1. The recommended node address is a node address for which the I/O area will not overlap with the area for other remote I/O.

The recommended node address (i.e., the next node address for which the I/O area will not overlap with the area for other remote I/O) is automatically displayed.



Precautions for Correct Use

- If a node address is set that causes a remote I/O area to overlap with an I/O area for another slave, a message will be displayed saying that the areas overlap. If this happens, change the node address so that the areas do not overlap.
- To start the CX-Drive from the project tree in the PCU Setting Window, right-click the registered Servo Drive and select Start Special Tool – Start with Settings Inherited. If the slave name uses characters specific to a particular language, this method cannot be used to start the CX-Drive when the saved project is opened in a CX-Programmer in another language. For example, if the slave name includes Japanese characters, the CX-Drive cannot be started from the project tree in the PCU Setting Window of an English version of CX-Programmer.

To use saved data in different language platforms, use single-byte alpha-numeric characters for the slave names in the slave properties.

Select the slave to add to the network and click the OK Button. The new slave will be displayed in the tree view as shown below.

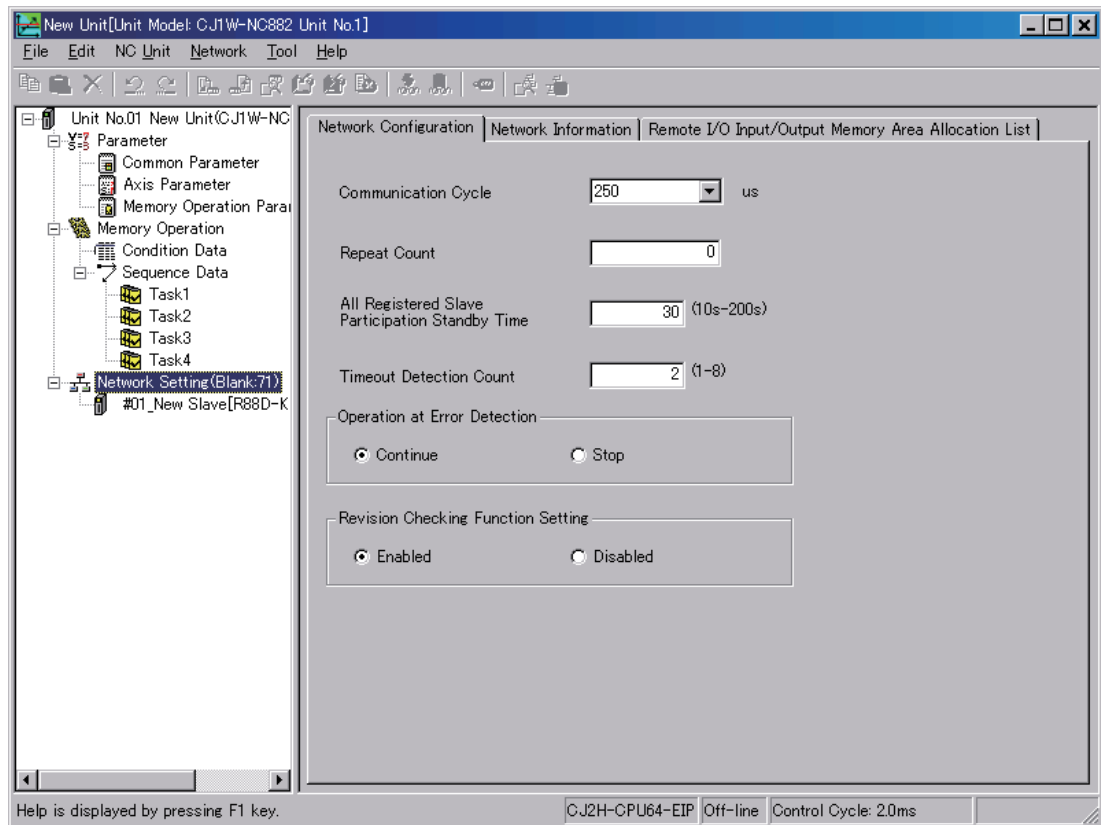

The lowest available node address will be calculated and set for the new node address.

When a Servo Drive is selected, the next available node address is automatically set starting from node address 1.

When a remote I/O slave is selected for the CJ1W-NC482/ 882/ F82, the next available node address is automatically set starting from node address 17.



Reference

Remote I/O slaves can also be selected for the CJ1W-NC281/481/881/F81. Node addresses will be set from node address 1 (the same as for Servo Drives).

Related Settings

Item	Setting Method
Changing the node address	Right-click the slave to change, select Change Slave Model from the pop-up menu, and edit the node address.
Changing the slave name	Use the same procedure as above to select Change Slave Model and change the slave name.

Deleting a Slave

When you delete a slave, it will be deleted from the network.

Execution Method

There are three ways that can be used to delete a slave.

- Select Delete Slave from the Network Menu.
- Right-click the slave to delete in the tree view and select Delete Slave from the pop-up menu.
- Select the slave in the tree view and press the Delete key.

Changing the Model of a Slave

You can change the model of a slave without changing the name, node address, or network location of the slave. Other settings are not changed. This function is convenient for changing the model of a slave without changing its location.

Execution Method

There are two ways that can be used to change the model of a slave.

- Select Change Slave Model from the Network Menu.
- Right-click the slave in the tree view and select Change Slave Model from the pop-up menu.

When this command is executed, a dialog box will be displayed to select the slave model.

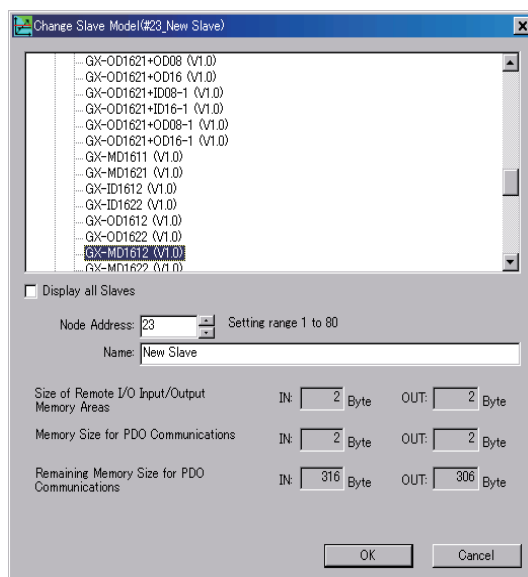

Select the new model from the list and press the OK Key. The model will be changed.

Moving Slaves

A specified slave can be moved up and down. This can be used to change the location of a slave in the network.

This function is convenient for changing the location of a slave without changing the settings of the slave.

Execution Method

There are three ways that can be used to change the location of a slave.

- ♦ Select Move Slave Upward/Down from the Network Menu.
- ♦ Right-click the slave to move in the tree view and select Move Slave Upward/Down from the popup menu.
- ♦ Select the slave in the tree view and press the Ctrl + ↑ or Ctrl + ↓ keys.

Enabling/Disabling Slaves

Control for a specified slave can be enabled or disabled.

This allows you to enable or disable a slave without changing the network settings or other settings. This function is convenient for temporarily disabling a slave.

This method differs in the following points compared with removing the slave completely from the network configuration information.

- ♦ Unit control performance is not affected by enabling or disabling the slave. (The communications cycle and control cycle remain the same.)
- ♦ Remote I/O Input/Output Memory Areas will be reserved, so the memory area allocations will not change.



Precautions for Correct Use

- ♦ When slaves are enabled or disabled, the network configuration must be transferred to the PCU again and saved, and the Unit must be restarted.
 - ♦ Make sure that the node address is specified in the slave before enabling or disabling the slave (e.g., set the node address on the rotary switches or in nonvolatile memory in the PCU). If the node address is specified in the network configuration in the PCU, the node addresses may change when the slave is disabled.
When using an OMNUC G5-series Servo Drive, set the node address to a value other than 00 and set the node address in the Servo Drive.
-

Execution Method

There are two ways that can be used to enable or disable a slave.

- ♦ Select Disable Slave or Enable Slave from the Network Menu.
- ♦ Right-click the slave in the tree view and select Disable Slave or Enable Slave from the pop-up menu.

Revision Checking Function Setting

With Support Software version 9.32 or later, the Revision Checking Function Setting is disabled by factory default.

If your version of Support Software supports the slave that you are adding, you can enable Revision Checking so that you can use Auto Setup to configure the slave.

If you want to replace or add a slave revision that is not supported by your version of Support Software, do the following:

To replace a connected slave

Disable the Revision Checking function and then replace the slave.

To add a new slave

Disable the Revision Checking function and then manually configure the slave.



Reference

Disabling the Revision Checking function to replace or add a slave as explained above may not allow you to use new functions available with the latest revision of the slave.

Make sure that your Support Software version provides support for the latest revision of the slave.

PDO Setup

You can select a certain set of PDO communications data for OMNUC G5-series Servo Drives (version 2.0 or later).

Thus you can change what data is controlled by your PCU.

When you select one of the following combinations of motion functions, the system automatically switches to the appropriate set of PDO communications data:

Motion function	PDO communications data		PDO communications size
	IN	OUT	
Position Control	0x1B01	0x1701	28 bytes
Position Control, Speed Control, Torque Control, Velocity Limitation	0x1B04	0x1702	29 bytes
Position Control, Speed Control, Torque Control, Velocity Limitation, Torque Limit	0x1B04	0x1704	29 bytes
Position Control, Speed Control, Torque Feedforward, Torque Limit	0x1B04	0x1705	29 bytes

Execution Method

Follow these steps:

From the tree view, select your desired OMNUC G5-series Servo Drive. On the PDO Setup tab displayed in the edit pane on the right-hand side, click the Select By Support Function button.

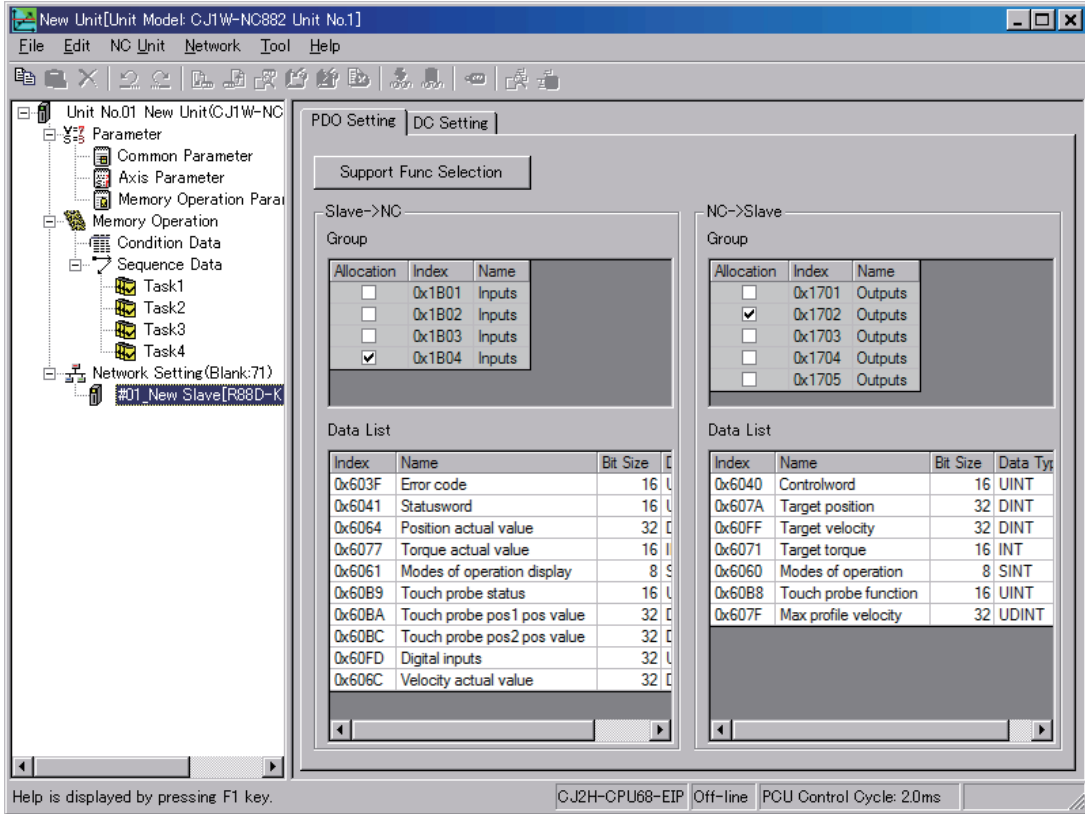

Select your desired functions on the dialog box that appears. If you perform full-closed loop control, select FUNC1.

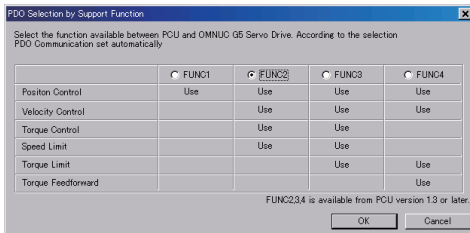

Slave Properties

The properties can be used to view the name, model, and other production information for the specified slave.

Execution Method

There are two ways that can be used to access the properties.

- Right-click the slave in the tree view and select Properties from the pop-up menu.
- Select Property from the Network Menu.

Displayed Properties

The following properties are displayed.

Name	Description
Vendor Name	Displays the vendor of the slave.
Group Type	Displays the model of the slave.
Model	Displays the model of the slave.
Revision	Displays the revision number of the slave.
Name	Displays the name of the slave.
Node Address	Displays the node address of the slave.
Position Address	Connection numbers are assigned starting from the slave closest to the PCU. The number is decremented from 0.
Memory Size for PDO Communication	Displays the size of memory used for PDO communications for the slave.
Vendor ID	Displays the vendor of the slave.
Product Code	Displays the product code of the slave.
Serial No.	Displays the serial number of the slave.

Installation and Wiring

This section describes the names and functions, installation method, wiring method, and other hardware information.

3-1	Part Names and Area Allocations	3-1
3-2	Installing the PCU	3-5
3-3	External I/O Circuits.....	3-8
3-4	Wiring.....	3-9
3-5	Connection Example for Servo Drives.....	3-13
3-6	Wiring Unused Axes	3-14
3-7	Wiring Check with the CX-Programmer.....	3-15

3-1 Part Names and Area Allocations

This section describes the names of PCU parts and allocations in the CPU Bus Unit Area.

Part Names

CJ1W-NC281/-NC481/-NC881/-NCF81
 CJ1W-NC482/-NC882/-NCF82

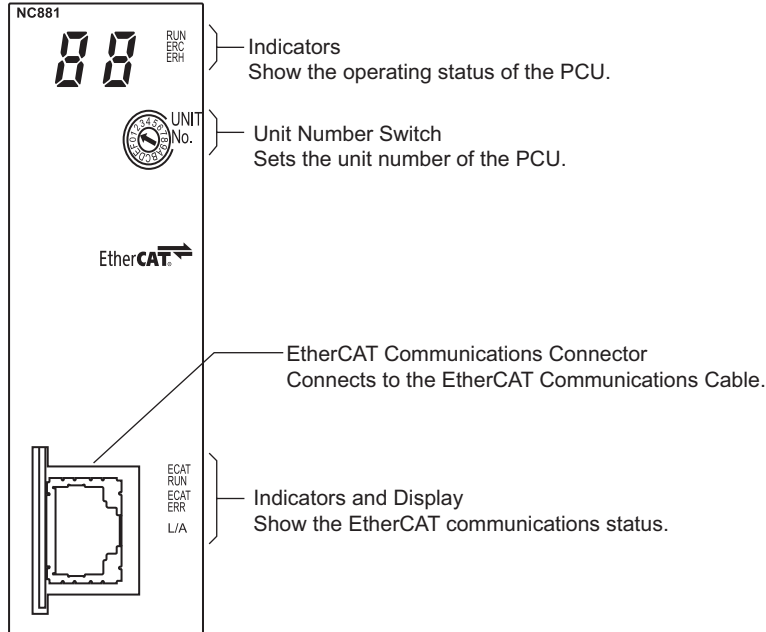

Indicators

Indicator	Display color	State	Description
RUN	Green	ON	Normal operation.
		OFF	The power supply is OFF, a hardware error has occurred, or the PLC has detected a PCU error.
ERC	Red	ON	An error has occurred.
		OFF	Other than the above
ERH	Red	ON	There is an error in the PLC.
		OFF	Other than the above
ECAT RUN	Green	OFF	Initialized state
		Blinking	Pre-Operational state
		Single flash	Safe-Operational state
		ON	Operational state

Indicator	Display color	State	Description
ECAT ERR	Red	OFF	No error
		Blinking	Communications setting error
		Single flash	Synchronization error or communications data error
		Double flash	Application WDT timeout
		Flickering	Boot error
		ON	PDI WDT timeout
L/A	Green	OFF	Link not established in physical layer.
		ON	Link established in physical layer.
		Flickering	In operation after establishing link.

Indicator status is described below.

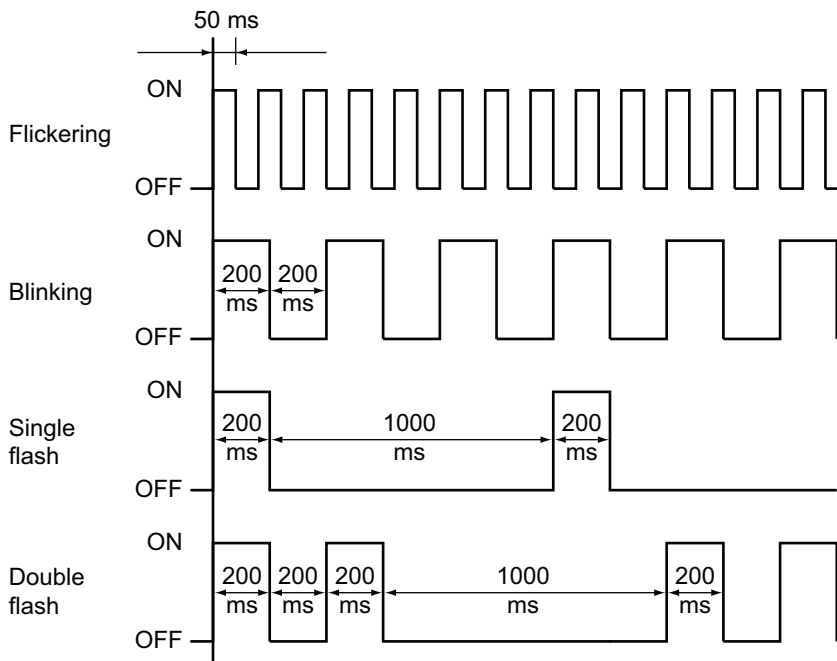



Reference

The 7-segment display on the front of the PCU displays information such as the error type when errors occur. The 7-segment display will be as follows during normal operation:

- ◆ When There Is No Network Configuration Information or EtherCAT Initialization

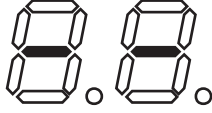

- ◆ During Normal Operation (i.e., during EtherCAT Communications)
When the Synchronous Data Link function is enabled in the CJ1W-NC□82 (PCU with unit version 1.3 or later), the dot to the right the first dot digit of the 7-segment display turns ON. When the Synchronous Data Link function is disabled, the first digit's dot is OFF.

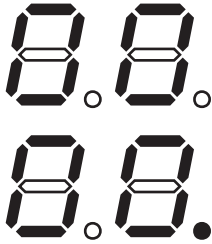

Unit Number Switch (UNIT No.)

This switch is used to set the unit number of the PCU as a CPU Bus Unit.



Setting range: 0 to F (unit numbers 0 to 15)

Note: The unit number is factory-set to 0.

The unit number that is set determines the words that are allocated to the PCU in the CPU Bus Unit Area in the CPU Unit.

Each CJ1W-NC281/481/881/F81/482/882/F82 PCU is allocated the words for one CPU Bus Unit. It is therefore allocated 25 words in the CPU Bus Unit Area.

Any unit number can be set as long as the same number has not been set for another CPU Bus Unit in the same PLC.



Precautions for Correct Use

- ◆ Make sure that the power supply is OFF when you perform settings.

EtherCAT Communications Connector

Connect the PCU to the EtherCAT devices using an EtherCAT Communications Cable.

Refer to 3-3 *External I/O Circuits* on page 3-8 for models of EtherCAT Communications Cables and connection examples.

Memory Area Allocation List

The unit number that is set determines the words that are allocated to the PCU in the CPU Bus Unit Area in the CPU Unit.

CPU Bus Unit Area

Each CJ1W-NC281/481/881/F81/482/882/F82 PCU is allocated 25 words as a PCU Control Memory Area.

Unit number	Allocated words	Unit number	Allocated words
0	1500 to 1524	8	1700 to 1724
1	1525 to 1549	9	1725 to 1749
2	1550 to 1574	10 (A)	1750 to 1774
3	1575 to 1599	11 (B)	1775 to 1799
4	1600 to 1624	12 (C)	1800 to 1824
5	1625 to 1649	13 (D)	1825 to 1849
6	1650 to 1674	14 (E)	1850 to 1874
7	1675 to 1699	15 (F)	1875 to 1899



Precautions for Correct Use

- ◆ Do not set the same unit number as another CPU Bus Unit in the same PLC. If the same unit number is used by more than one Unit, a fatal Unit number duplication error will occur and operation will stop.
- ◆ To perform axis control, direct operation, or memory operation, you also need to set the Direct Operation Command Memory Area and Memory Operation Command Memory Area, in addition to Unit Control Memory Area. For details, refer to 6-6 *Operation Memory Areas* on page 6-75.

3-2 Installing the PCU

This section describes the installation method of the PCU and provides its dimensions.

System Configuration Precautions

- ◆ The words that are allocated to the PCU in the CPU Bus Unit Area are determined by the unit number that is set on the front panel of the PCU. They are not determined by the location in which the PCU is connected in the PLC.
- ◆ The PCU can be connected in a CPU Rack or Expansion Rack. You can connect up to 16 PCUs per PLC. You can connect up to 10 CJ-series Configuration Units in one CPU Rack or Expansion Rack.



Precautions for Correct Use

- ◆ The upper limit of the current or power that can be supplied to mounted Units is determined by the model of the Power Supply Unit that is mounted to the CPU Rack or Expansion Rack of the PLC.
- ◆ Design your system so that the total current consumption of the mounted Units does not exceed the maximum current for each voltage group and the total power consumption does not exceed the upper limit for the Power Supply Unit.
- ◆ Refer to the manual for the CPU Unit for the method to calculate the current consumption of mounted Units.

PCU Installation Method

Use the following procedure to install the PCU.

1. **Align the connectors properly and then mount the PCU.**

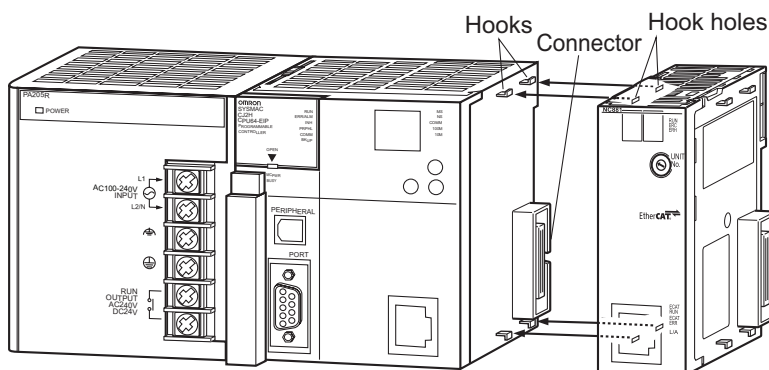

- Slide the yellow sliders at the top and bottom of the PCU until you hear them lock into place.

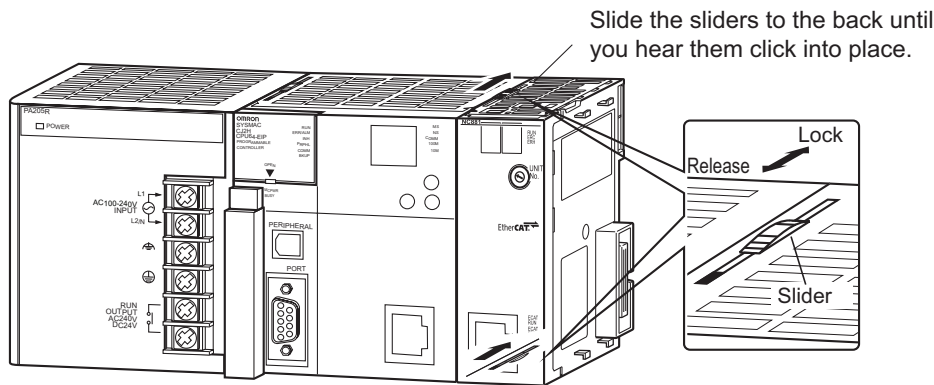

Precautions for Correct Use

- If you do not lock the sliders properly, the PCU may not function properly.

To remove the PCU, slide the sliders in the “release” direction to unlock the sliders.

PCU Handling Precautions

- Always turn OFF the power supply to the PLC before you mount or remove the PCU and before you connect or disconnect PCU wires.
- To prevent negative effects from noise, wire the I/O lines in separate ducts from high-voltage lines and power lines.
- Wire scraps may scatter during wiring. To prevent wire scraps from entering the PCU, do not remove the label on the top of the PCU until wiring has been completed. Once wiring has been completed, be sure to remove the label to allow heat radiation.

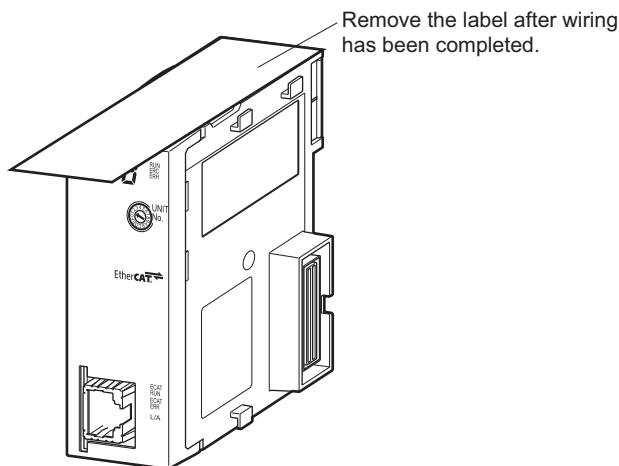

Dimensions

CJ1W-NC281/-NC481/-NC881/-NCF81/-NC482/-NC882/-NCF82

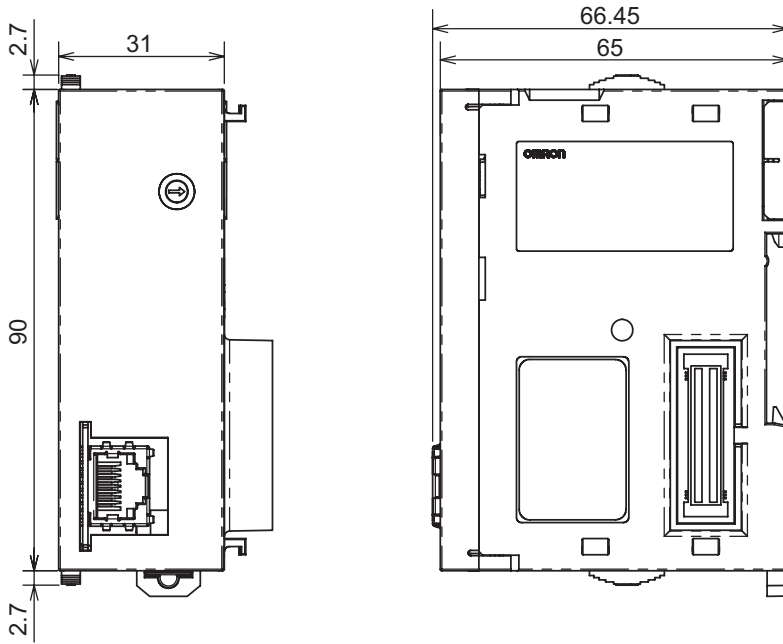

3-3 External I/O Circuits

This section describes the external I/O that is used when a PCU is connected to a G5-series Servo Drive with Built-in EtherCAT (R88D-KN□-ECT(-R)).

PCU I/O Signals

The PCU has only one EtherCAT communications connector.

EtherCAT Communications Connector

This connector is used to connect the EtherCAT twisted-pair cable.

Connector Specifications

Specification	Description
Electrical characteristics	Conforms to IEEE 802.3 standards.
Connector structure	RJ45 8-pin modular connector (Conforms to ISO 8877.)

Pin Assignments

	Pin No.	Signal name	Abbreviation	Signal direction
	1	Transmission data +	TD+	Output
	2	Transmission data -	TD-	Output
	3	Reception data +	RD+	Input
	4	Not used.	---	---
	5	Not used.	---	---
	6	Reception data -	RD-	Input
	7	Not used.	---	---
	8	Not used.	---	---
	Hood	Frame ground	FG	---



Reference

Refer to the *OMNUC G5-series Servo Drives with Built-in EtherCAT Communications User's Manual* (Cat. No. I573) for information on OMNUC G5-series Servo Drive connections.

3-4 Wiring

This section describes OMNUC G5-series Servo Drive connections and provides a connection example for Servo Drive control I/O.

Wiring EtherCAT Communications

An EtherCAT Communications Cable is used to connect the PCU with Servo Drives or other EtherCAT slaves.

Use a category 5 or higher cable with double, aluminum tape and braided shielding.

Use a category 5 or higher, shielded connector.



Precautions for Correct Use

- ♦ The maximum distance between any two nodes is 100 m. Some cables, however, are not rated for 100 m. Generally speaking, the transmission performance of stranded wires is worse than that of solid wire. Cables with stranded wires generally are not rated for 100 m. Contact the cable manufacturer for details.
- ♦ When selecting a connector, make sure that it is suitable for the cable that you are using. The following items must be confirmed: conductor size, whether connector is solid or stranded wire, whether there are 2 wire pairs or 4, the outside diameter, etc.



Reference

As long as you use a category 5 or higher Ethernet cable, communications will be possible either with or without a shield. However, to ensure sufficient immunity to noise, we recommend cable with double, aluminum tape and braided shielding.

Wire Gauge and Number of Pairs: AWG24, 4-pair Cable

EtherCAT Communications Cables

The following cable is recommended.

Recommended manufacturer	Model	Contact information
Tonichi Kyosan Cable, Ltd.	NETSTAR-C5E SAB 0.5 × 4P	Kanetsu Co.
Kuramo Electric Co.	KETH-SB	Kuramo Electric Co.
SWCC Showa Cable Systems Co.	FAE-5004	SWCC Showa Cable Systems Co.

Connector (Modular Plug) Specifications

The following connector is recommended.

Recommended manufacturer	Model	Contact information
Panduit Corporation	MPS588	Panduit Corporation Japan Branch Osaka Sales Office

Attaching the Connectors to the Cable

Use straight wiring to attach the connectors to the communications cable.

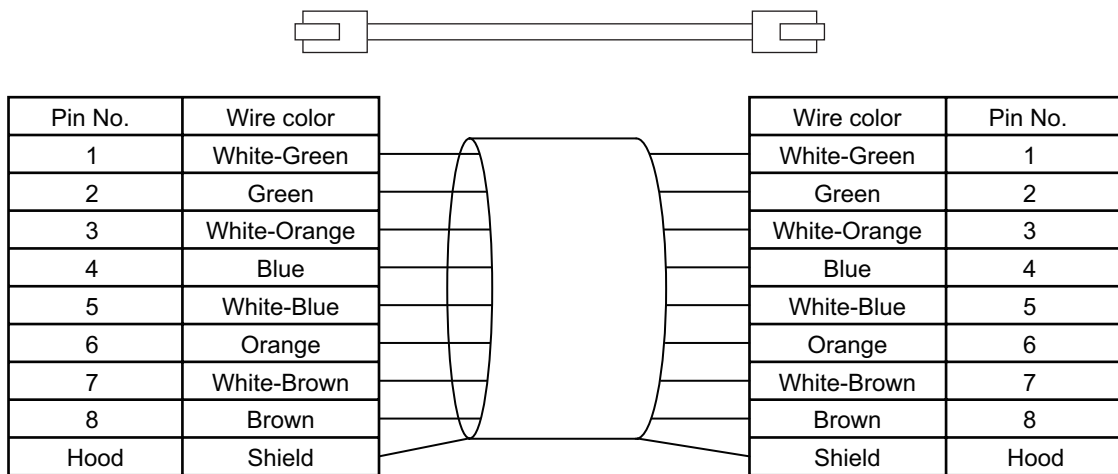

Note 1. Connect the cable shield to the connector hood at both ends of the cable.

Note 2. There are two connection methods for Ethernet: T568A and T568B. T568A is shown above, but T568B can also be used.

Wire Gauge and Number of Pairs: AWG22, 2-pair Cable

EtherCAT Communications Cables

The following cable is recommended.

Recommended manufacturer	Model	Contact information
Kuramo Electric Co.	KETH-PSB-OMR	Kuramo Electric Co.

Connector (Modular Plug) Specifications

The following connector is recommended.

Recommended manufacturer	Model
OMRON	XS6G-T421-1

Wiring Servo Drive I/O Signals

This section provides a connection example for Servo Drive control I/O signals when the PCU is used together with an OMNUC G5-series Servo Drive.

Refer to the *OMNUC G5-series Servo Drives with Built-in EtherCAT Communications User's Manual* (Cat. No. I573) for information on the Servo Drive power supply and connections to Servomotors.

Connection Example for Control I/O Connector (CN1)

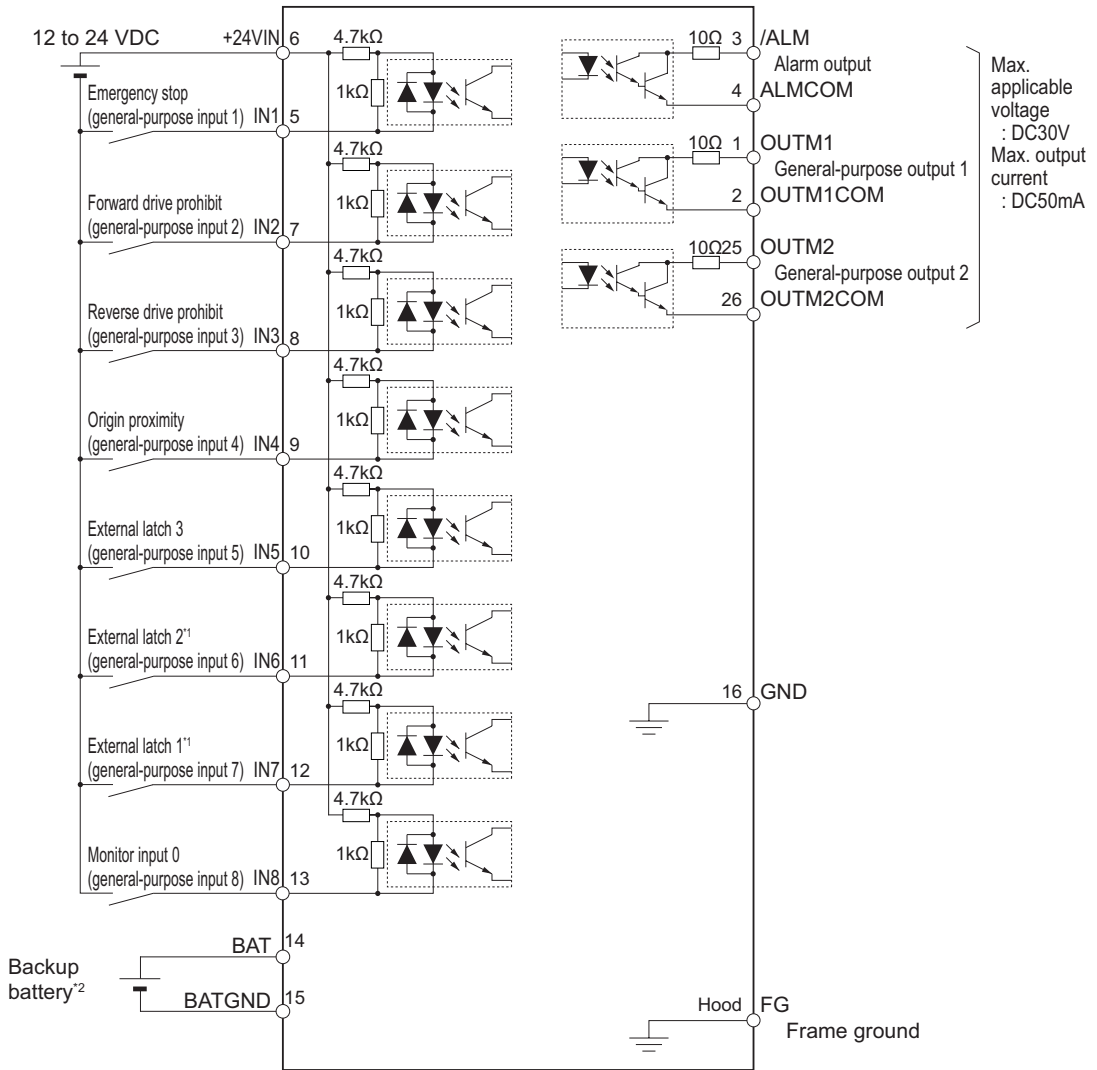

Max. applicable voltage : DC30V
Max. output current : DC50mA

*1. With the default settings of the OMNUC G5-series Servo Drive, external latch 1 is the external origin input and external latch 2 is the external interrupt input.

*2. A battery with a cable is not required when connecting a backup battery.

Note 1. Parameters can be set to assign functions to the general-purpose inputs on pins 5, 7, 8, 9, 10, 11, 12, and 13.

Note 2. Parameters can be set to assign functions to the general-purpose outputs on pins 1, 2, 25, and 26.



Precautions for Correct Use

- ♦ The forward drive prohibit input (POT), reverse drive prohibit input (NOT) and origin proximity input (DEC) assigned to external inputs of the Servo Drive are used for the PCU as the Forward Limit Input Flag, Reverse Forward Limit Input Flag, and Origin Proximity Input Flag. Make sure that the signal widths for all of these input signals are longer than the control cycle of the PCU. If the input signal widths are shorter than the control cycle, the PCU may not be able to detect the input signals, resulting in incorrect operation.
 - ♦ When controlling a Servo Drive with EtherCAT communications, PCU controls, Servo Drive drive prohibit inputs, and stop processing for the Servomotor when errors occur are performed using software. Always implement safety measures outside of the Servo Drive to enable stopping in an emergency, such as a shutoff circuit for the main Servo Drive power supply.
-

3-5 Connection Example for Servo Drives

This section shows the connection method for the EtherCAT communications cable between the PCU and slave devices.

The cable is connected between the PCU and the ECAT IN connector on the slave device. The ECAT OUT connector on the slave device is then connected to the ECAT IN connector on the next slave device. The ECAT OUT connector on the last slave device is not connected to anything.

Connection Examples for Servo Drive

This section shows a connection example for the EtherCAT communications cable between the PCU and OMNUC G5-series Servo Drives.

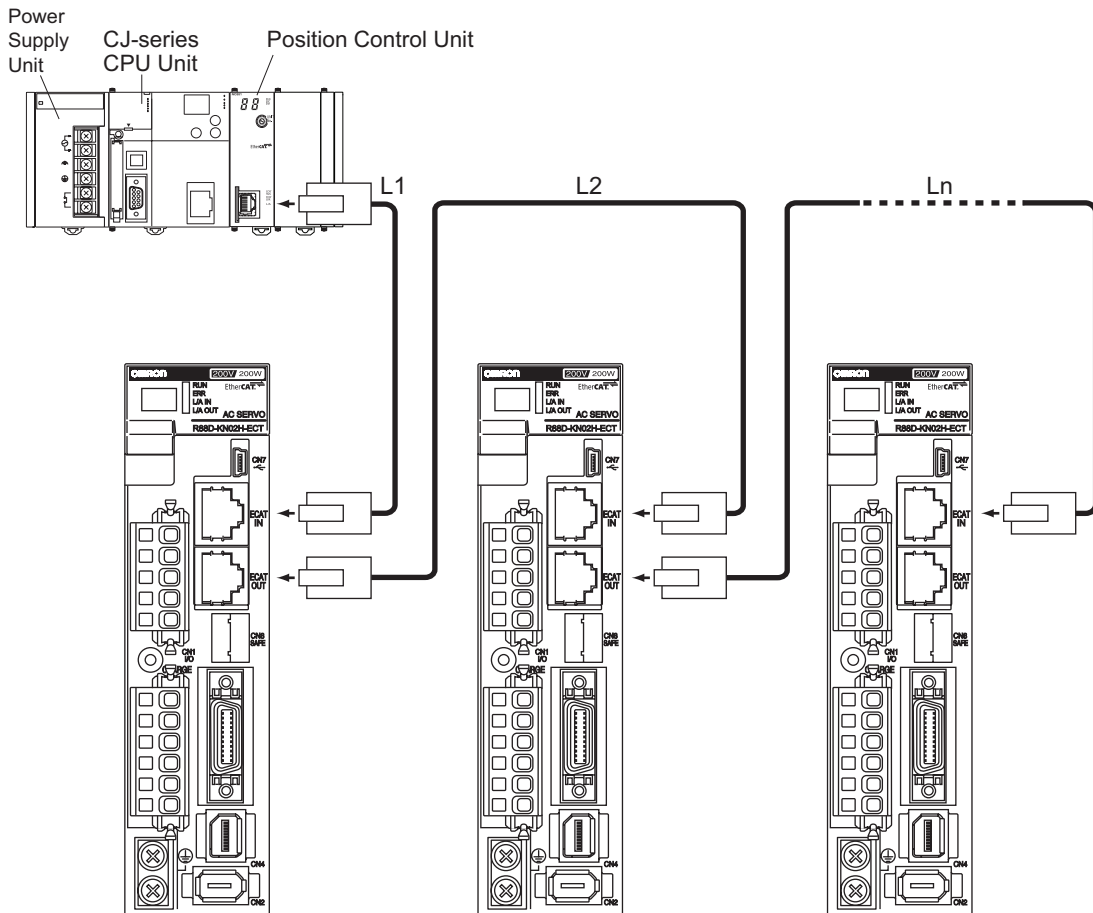

Precautions for Correct Use

- ♦ Always turn OFF the power supply to the PCU and Servo Drives before connecting or disconnecting the EtherCAT communications cable.
- ♦ Do not exceed 100 m between any two nodes (L1, L2...Ln).
- ♦ Do not use Ethernet hubs to relay the network. EtherCAT communications will not be performed normally if an Ethernet hub is used.

3-6 Wiring Unused Axes

This section describes what to do when not all of the PCU axes are used.

Set the Axis Type axis parameter to specify whether a given axis is used.

Parameter name	Function	Setting range	Unit	Default setting
Axis Type	Set the axis type. 0: Physical axis, 2: Unused axis	0 or 2	–	0

I/O wiring is not required for axes that are set as unused axes.



Precautions for Correct Use

- ♦ Select Physical Axis for axes that are actually wired to operate, and select Unused Axis for other axes.

3-7 Wiring Check with the CX-Programmer

You can use the CX-Programmer to check the wiring.

You can manually operate the I/O signals of the Servo Drive connector and external signal connector.

Operating Procedure

1. Connect online to the PLC from the CX-Programmer.
2. Open the PCU Setting Window.
3. Select Test Run from the NC Unit Menu.

When the precaution dialog box below appears, read the message carefully. After you confirm safety, click the OK Button.

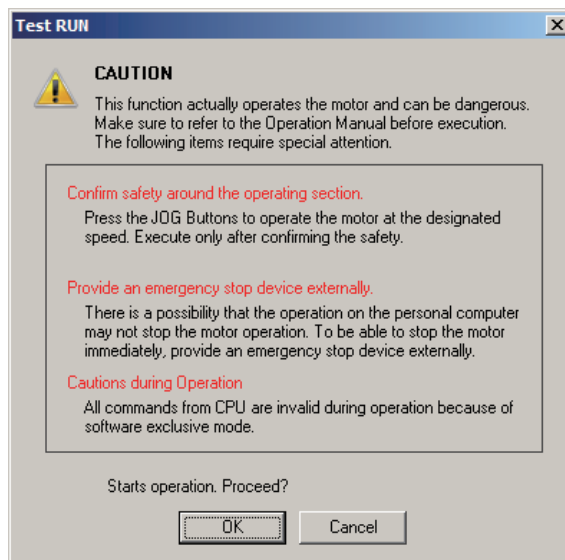

Precautions for Correct Use

- ◆ When you click the OK Button, the PCU will enter Support Software-controlled Operation Mode. Refer to *4-1 Outline of Manual Operation* on page 4-1 for information on Support Software-controlled Operation Mode.

4. When the Test Run Dialog Box appears, click the Wiring Test Tab.

The following dialog box will appear.

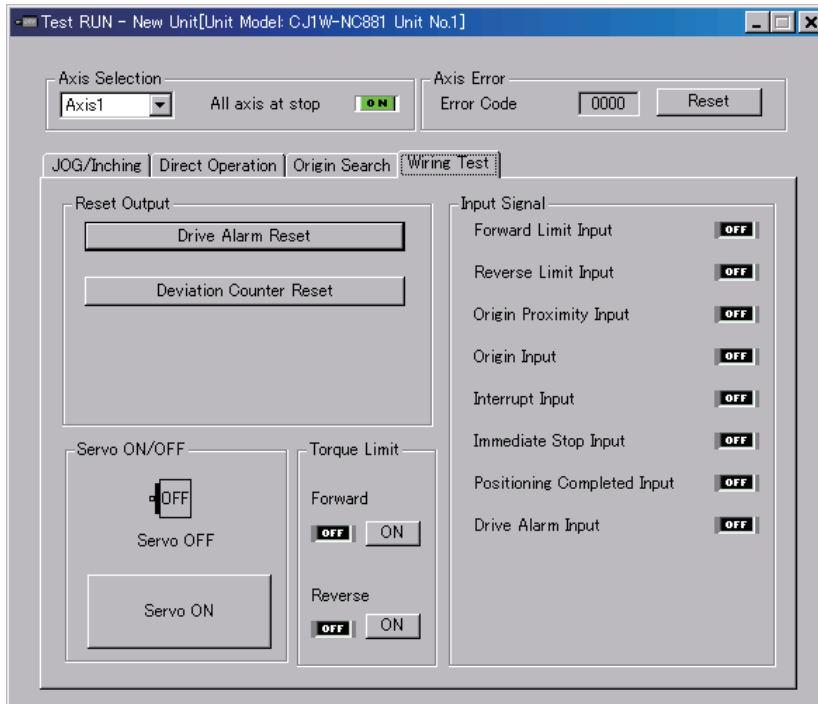

5. Select the axis whose wiring you want to check.

6. In the Output Signal and Input Signal Areas, **ON and **OFF** indicate the current status.**

7. In the Output Signal Area, click the **ON buttons of the outputs you want to turn ON.**

8. In the Output Signal Area, click the **OFF buttons of the outputs you want to turn OFF.**

4

Manual Operation

This section describes manual operation for jogging and inching when the Position Control Unit (PCU) is used together with an OMNUC G5-series Servo Drive.

4-1	Outline of Manual Operation	4-1
4-2	Jogging	4-3
4-3	Inching	4-11
4-4	Operations with CX-Programmer	4-14

4-1 Outline of Manual Operation

The operating information in the remainder of this manual assumes that the Position Control Unit is used together with an OMNUC G5-series Servo Drive.

Some parameters must be set before you can use manual operation.

This section describes operating procedures for jogging and inching. It also describes the minimum parameters that are required for operation.

Manual operation is necessary to confirm that the motor rotates according to the commands as soon as wiring is completed.

If you can confirm that the motor operation is performed according to commands in manual operation, then you can be sure that the wiring is correct.



Precautions for Correct Use

Direct operation can be used only when the Position Control Unit is used together with an OMNUC G5-series Servo Drive.

PCU Operating Modes

The PCU has the following operating modes. The operations that can be performed from the PLC depend on the operating mode.

Operating mode	Description of operating status	PCU status			Operation from PLC
		PCU Ready Flag	EtherCAT communications control state	PDO communications output	
Initializing Mode	The PCU is in Initializing Mode from when you turn ON the power supply or restart the PCU until the PCU and EtherCAT communications start. In this mode, the PCU Ready Flag (word n+11, bit 15) ^{*1} is OFF.	OFF	Init to Safe-Operational	–	Not possible.
PCU Setup Mode	In this mode, the PCU Setup Flag (word n, bit 15) ^{*1} is ON and the PCU Ready Flag is OFF.	OFF	Pre-Operational	–	Only the PCU Control Memory Area will operate.
Support Software-controlled Data Transfer Mode	Support Software-controlled Data Transfer Mode is entered in response to a command from the CX-Programmer. In this mode, data can be transferred to and from the CX-Programmer. Ladder program outputs are disabled.	OFF	Pre-Operational	–	Not possible.

Operating mode	Description of operating status	PCU status			Operation from PLC
		PCU Ready Flag	EtherCAT communications control state	PDO communications output	
Support Software-controlled Operation Mode	Support Software-controlled Data Transfer Mode is entered in response to a command from the CX-Programmer. In this mode, operation from the CX-Programmer is possible. Ladder program outputs are disabled.	OFF	Operational	This output status prior to entering Support Software-controlled Operation Mode will be held.	Not possible.
Normal Operation Mode	In Normal Operation Mode, the PCU Ready Flag is ON.	ON	Operational	Normal operation	Possible.

*1. "Word n" is the first word allocated to the PCU in the CPU Bus Unit Area. You can calculate the first word in the CPU Bus Unit Area using the following formula:

First word allocated to PCU in CPU Bus Unit Area, $n = \text{CIO } 1500 + 25 \times \text{unit number}$



Reference

- Manual operation can be performed using either of two methods: using Support Software-controlled Operation Mode (i.e., from the CX-Programmer) or using normal operation from a PLC ladder program.

4-2 Jogging

When one of the Jogging/Inching Bits is turned ON, the axis accelerates for the specified jog acceleration time in the specified direction to the specified jogging speed. When you turn OFF the Jogging/Inching Bit, the axis decelerates to a stop over the specified jog deceleration time.

Jogging is possible even when the origin has not been defined.

Operating Procedure

1. Common Parameter Settings

To perform jogging, set the Manual Operation Command Memory Area common parameter.

2. EtherCAT Communications Settings

Execute automatic network setup by selecting Network Auto Setup from the Network Menu on the menu bar.

3. Axis Parameter Settings

Set the axis parameters, such as the I/O function and jogging speed parameters.

4. Transferring Data

Transfer the common parameters and axis parameters to the PCU.

5. Restarting the PCU

Restart the PCU to enable the transferred parameters.

6. Place the Servo Drive in operating status and lock the servo.

7. Select the jogging speed.

8. Turn ON the Jogging/Inching Bit to perform jogging.

Common Parameter Settings

Use the CX-Programmer to set the common parameters for the PCU.

1. Start the CX-Programmer.

2. Connect the CX-Programmer online to the PLC.

After the CX-Programmer is connected, change the CPU Unit to PROGRAM mode.

3. Double-click IO Table and Unit Setup in the project tree of the CX-Programmer.

The IO Table Window will appear for a new PLC.

4. In the IO Table Window, double-click the PCU.

The PCU Setting Window will appear.

5. Click Common Parameter in the project tree in the PCU Setting Window.

The window for setting common parameters will appear.

6. Select Operation Memory Area Allocation Setting in the Parameter Type Box.

7. Select the Manual Operation Command Memory Area Selection parameter.

Select one of the five areas: CIO Area, WR Area, HR Area, DM Area, or EM Area.

8. Enter the address for the First Word of Manual Operation Command Memory Area parameter.

9. Execute automatic network setup by selecting Network Auto Setup from the Network Menu on the menu bar.

Executing this command will automatically set up communications for EtherCAT.



Reference

- If you want to perform only jogging, you can operate the axis using only the above common parameter settings.

Setting Example

This example shows the settings for a CJ1W-NC881 Position Control Unit for the following conditions.

- The unit number of the PCU is 3.
- The Work Area is set for the Manual Operation Command Memory Area and W100 is set as the first word in the Work Area.

These settings are made as follows:

- 1) Select WR Area for the Manual Operation Command Memory Area Selection in step 7 on the previous page.
- 2) Enter 100 for the First Word of Manual Operation Command Memory Area in step 8 on the previous page.

The above steps will set W100 to W115 as the Manual Operation Command Memory Area.

Manual Operation Command Memory Area

Word	Name	Bit	Bit name	Function
W100	Axis 1 Manual Operation Command Bits	0	Servo Lock Bit	Turn ON this bit to lock the servo.
		5	Override Enable Bit	Specify whether to enable or disable an override.
		6	Jogging/Inching Speed Selection Bit	Select the jogging/inching speed. Turn OFF this bit to select speed 1 and turn ON this bit to select speed 2.
		7	Forward Jogging/Inching Bit	Turn ON this bit to perform jogging or inching in the forward direction.
		8	Reverse Jogging/Inching Bit	Turn ON this bit to perform jogging or inching in the reverse direction.
		13	Immediate Stop Bit	Turn ON this bit to start performing an immediate stop.
		14	Deceleration Stop Bit	Turn ON this bit to start performing a deceleration stop.
		15	Servo Unlock Bit	Turn ON this bit to unlock the servo.
W101	Axis 1 Override	0 to 15	–	Set the override in hexadecimal. You can set any value from 1 to 50,000 (0001 to C350 hex), which correspond to 0.01% to 500.00%.
W102	Axis 2 Manual Operation Command Bits	0 to 15	Refer to the description for axis 1.	
W103	Axis 2 Override	0 to 15		

Word	Name	Bit	Bit name	Function
W104	Axis 3 Manual Operation Command Bits	0 to 15		Refer to the description for axis 1. These words are not used for a two-axis PCU.
W105	Axis 3 Override	0 to 15		
W106	Axis 4 Manual Operation Command Bits	0 to 15		Refer to the description for axis 1. These words are not used for a two-axis PCU.
W107	Axis 4 Override	0 to 15		
W108	Axis 5 Manual Operation Command Bits	0 to 15		Refer to the description for axis 1. These words are not used for a two-axis or four-axis PCU.
W109	Axis 5 Override	0 to 15		
W110	Axis 6 Manual Operation Command Bits	0 to 15		
W111	Axis 6 Override	0 to 15		
W112	Axis 7 Manual Operation Command Bits	0 to 15		
W113	Axis 7 Override	0 to 15		
W114	Axis 8 Manual Operation Command Bits	0 to 15		
W115	Axis 8 Override	0 to 15		

Axis Parameter Settings

- 1. Click Axis Parameter in the project tree in the PCU Setting Window.**
The window for setting the axis parameters will appear.
- 2. Select IO Function Setting in the Parameter Type Box.**
Select the input types for the connected sensors.
- 3. Select Acceleration/Deceleration Setting in the Parameter Type Box.**
Set the Maximum Speed parameter.
- 4. Select Command Position Unit Setting in the Parameter Type Box.**
Set the Command Pulse Count Per Motor Rotation and Work Travel Distance Per Motor Rotation parameters.
- 5. Select JOG/Inching Setting in the Parameter Type Box.**
Set the Jogging/Inching Speed 1 and Jogging/Inching Speed 2 parameters.

**Reference**

- ♦ If you want to perform only jogging, all other axis parameters can be left at their default values.

Setting Example

This example shows the PCU settings for the following conditions.

- ♦ No sensors are connected (because here only test operation is performed).
- ♦ A Servomotor is connected and the maximum speed is set to 3,000 r/min.
- ♦ The encoder resolution is 2,000 pulses, and the work travel distance per motor rotation is also 2,000 pulses.
- ♦ The jogging speeds are 300 r/min for speed 1, and 600 r/min for speed 2.

These settings are made as follows:

- 1) You can calculate the maximum speed for step 3 on page 4-5 with the following formula.
Maximum speed set on the Support Software in command units/s =

$$\frac{(\text{Maximum motor speed in pulses/s}) \times (\text{Unit multiplier}) \times (\text{Travel distance per motor rotation in command units})}{(\text{Number of command pulses per motor rotation in pulses})}$$
 The maximum motor speed is 3,000 r/min and the encoder resolution is 2,000 pulses, so the maximum motor speed is 100,000 pulses/s.
 The number of command pulses per motor revolution and the travel distance per motor revolution are both 2,000 pulses, so if the unit multiplier is 1, then the above formula shows that the maximum speed is 100,000 command units/s.
 Therefore, enter 100,000 as the set value.
- 2) The Command Pulse Count Per Motor Rotation and Work Travel Distance Per Motor Rotation parameters in step 4 on page 4-5 are both 2,000 pulses, so enter 2000 for both of them.
- 3) Jogging/inching speed 1 in step 5 on page 4-5 is 10 kpps, so enter 10,000 for the parameter. Jogging/inching speed 2 is 20 kpps, so enter 20000 for the parameter.

Setting Jogging/Inching Parameters

In the setting example, only the minimum required parameters are set. The Jogging/Inching Setting axis parameters are described in more detail below.

Parameter name	Function	Setting range	Unit	Default value
Inching Width	Set the amount of movement for inching. If you set this parameter to 0, axis operation will be the same as for jogging.	0 to 65,535 ^{*1}	Command units ^{*2}	0
Jogging/Inching Speed 1	Set jogging/inching speed 1.	1 to 2,147,483,647 ^{*1}	Command units ^{*2} per second	1,000
Jogging/Inching Speed 2	Set jogging/inching speed 2.	1 to 2,147,483,647 ^{*1}	Command units ^{*2} per second	10,000
Jogging Acceleration Time	Set the acceleration time for jogging.	0 to 250,000	ms	1,000
Jogging Deceleration Time	Set the deceleration time for jogging.	0 to 250,000	ms	1,000

4-2 Jogging

- *1. The parameter can be set in command units, but the setting is limited by the setting range when the value is converted to pulses.
- *2. For information on the command unit, refer to *Command Position Unit Setting* on page 6-40.

Inching Width

Set the amount of movement per inching operation. If you set the amount of movement to 0, the axis will operate in the same way as for jogging.

Jogging/Inching Speeds

These parameters are the speed commands for jogging and inching. You can set two speeds, speed 1 and speed 2, and change between these speeds during operation.

Jogging Acceleration Time and Jogging Deceleration Time

Set the acceleration time and deceleration time for jogging and inching.

The setting of the Acceleration/Deceleration Time Selection parameter determines the meaning of the Jog Acceleration Time and Jog Deceleration Time parameters.

For details, refer to *Acceleration/Deceleration Settings* on page 6-36 and *Acceleration/Deceleration Time Selection* on page 6-38.



Reference

- ♦ The previous setting example does not describe the command unit. However, most axis parameters are set to the default values, so the command unit is set to one pulse.
- ♦ All setting ranges are based on conversions to pulses.

Transferring Parameters and Restarting

Transfer the common parameters and axis parameters to the PCU, and then restart the PCU.

1. In the PCU Setting Window, select **Transfer Selection [PC to NC]** from the PCU Setting Window.
2. Select the **Specified Data Option** in the **Transfer Selection [PC to NC] Dialog Box**, select only the **Parameter Check Box**, and then click the **Changed Data Button**. Also select the **Save to the flash memory after downloading Check Box** and click the **OK Button**.
The transfer will start and the progress of transfer will be displayed.
3. A transfer confirmation message will be displayed. Click the **OK Button**.
4. After all data has been saved to flash memory, a restart confirmation message will appear. Click the **OK Button**.

This completes the transfer and restart procedure.



Reference

- ♦ Previously it was necessary to cycle the PLC power supply or to turn ON the Unit Restart Bit to restart a PLC Unit. As a result, the CPU Unit's cycle stopped every time you restarted a Unit. This Position Control Unit has a PCU Setup Bit (word n, bit 15) that can be used to restart the

Unit without stopping the CPU Unit.
For details, refer to *9-8 PCU Setup* on page 9-59.

Timing Chart

The timing chart for jogging axis 1 is given below.

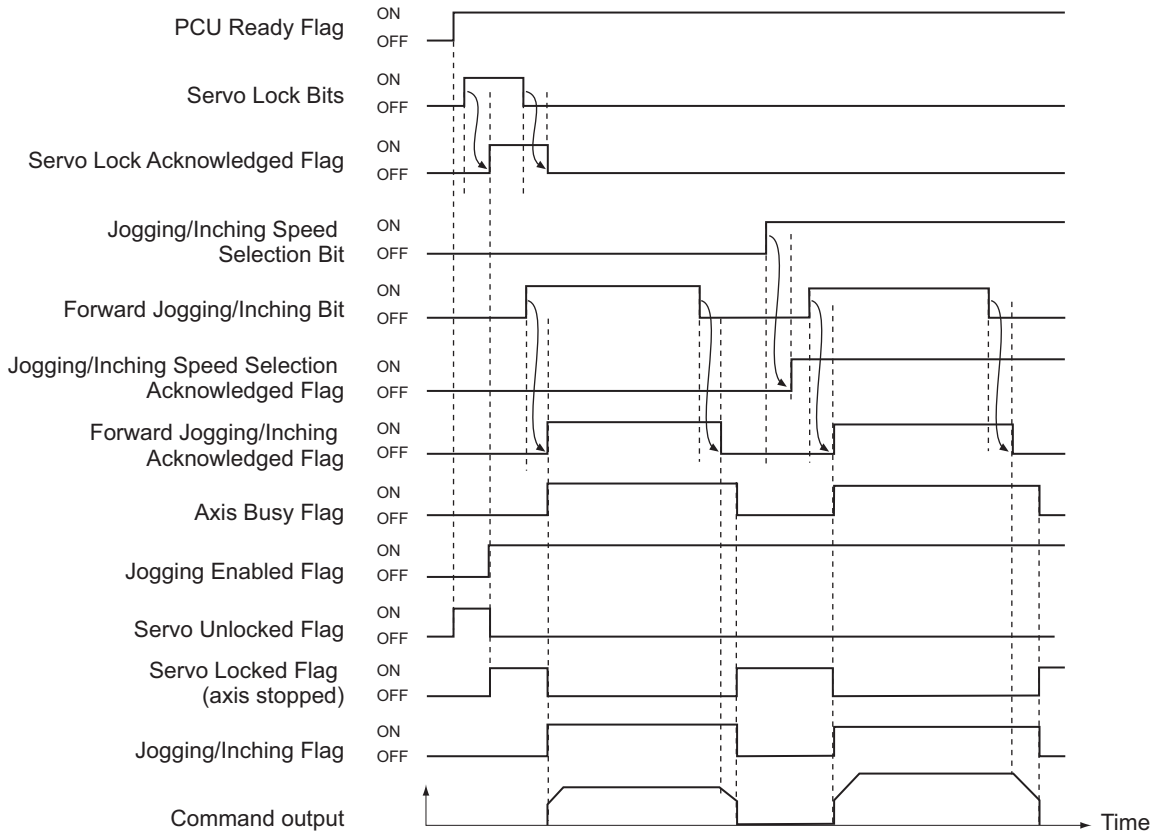

The Positioning Operation Completed Flag turns OFF when jogging starts.

Program Example

An example of programming to jog axis 1 is provided below.

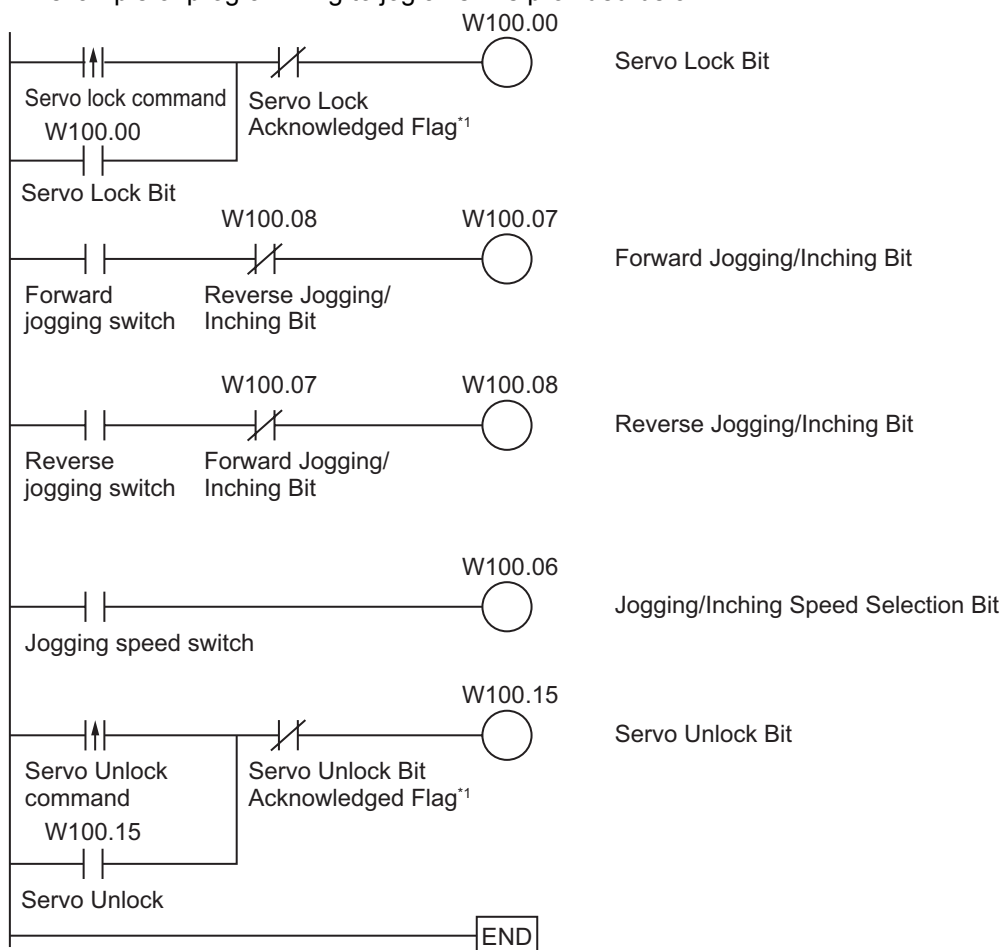

*1. When locking and unlocking the servo from the ladder program, keep the command bit ON until the Servo Lock Acknowledged Flag or Servo Unlock Acknowledged Flag turns ON in the Axis Status Memory Area.



Reference

- Other operations cannot be started while jogging is being performed.

4-3 Inching

Inching is used to move an axis by a specified distance and then stop.

Basically, inching uses the same parameters as jogging. (Jogging is described in the previous section.) If you set the amount of movement in the Inching Width parameter in the Jogging/Inching Setting parameters, the PCU will perform inching instead of jogging. If you set the Inching Width parameter to 0, the PCU will perform jogging.

Operating Procedure

The procedure is almost the same as the jogging procedure given in the previous section.

1. Common Parameter Settings

To perform inching, set the Manual Operation Command Memory Area common parameter.

2. EtherCAT Communications Settings

Execute automatic network setup by selecting Network Auto Setup from the Network Menu on the menu bar.

3. Axis Parameter Settings

Set the axis parameters, such as the inching speed parameters.

4. Transferring Data

Transfer the common parameters and axis parameters to the PCU.

5. Restarting the PCU

Restart the PCU to enable the transferred parameters.

6. Place the Servo Drive in operating status and lock the servo.

7. Select the jogging/inching speed.

8. Turn ON the Jogging/Inching Bit to perform inching.

The settings of the common parameters are the same as those for jogging. Refer to *Common Parameter Settings* on page 4-3.

Axis Parameter Settings

The axis parameters are also roughly the same as those for jogging. Therefore, this section describes only the additional parameters that require setting.

1. Click Axis Parameter in the project tree in the PCU Setting Window.

The window for setting the axis parameters will appear.

2. Select JOG/Inching Setting in the Parameter Type Box.

Set the amount of movement per one inching operation in the Inching Width parameter.

Setting Example

This example shows the PCU settings for the following conditions.
 ♦ One inching operation turns the motor by 0.5 rotation.

These settings are made as follows:

The encoder resolution is 2,000 pulses. For the Inching Width parameter in step 2 above, set 1,000 pulses to turn the motor by 0.5 rotation.

To enable the new parameter setting, transfer the parameters to the PCU and restart the PCU. For details, refer to *Transferring Parameters and Restarting* on page 4-7.

Timing Chart

The timing chart for inching axis 1 is given below.

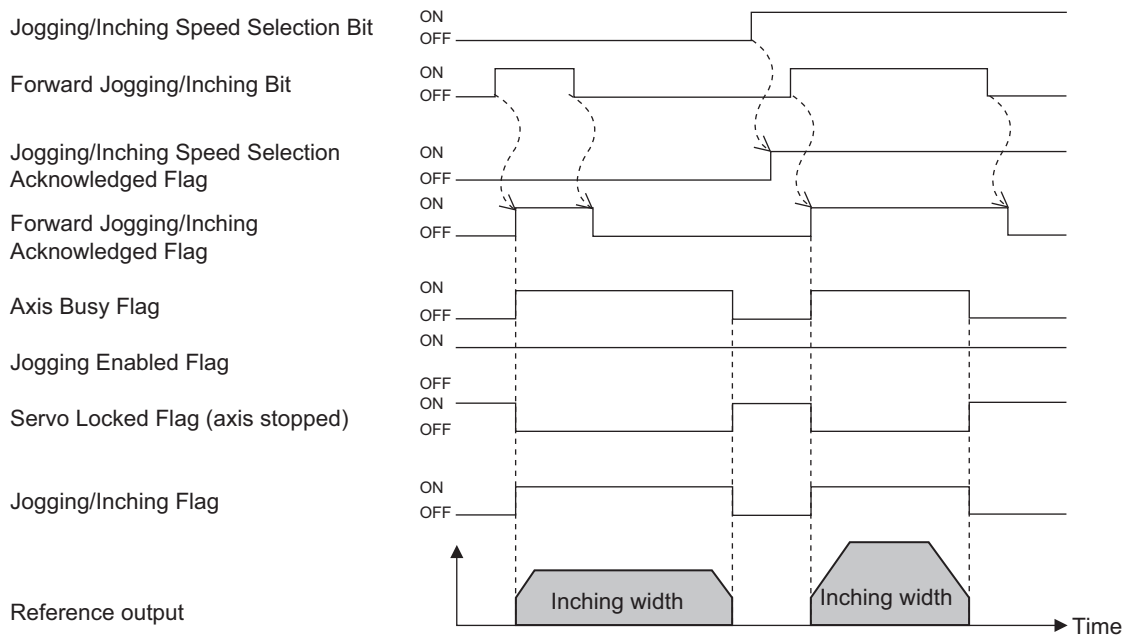

The Positioning Operation Completed Flag turns OFF when inching starts.

Program Example

An example of programming to inch axis 1 is provided below.

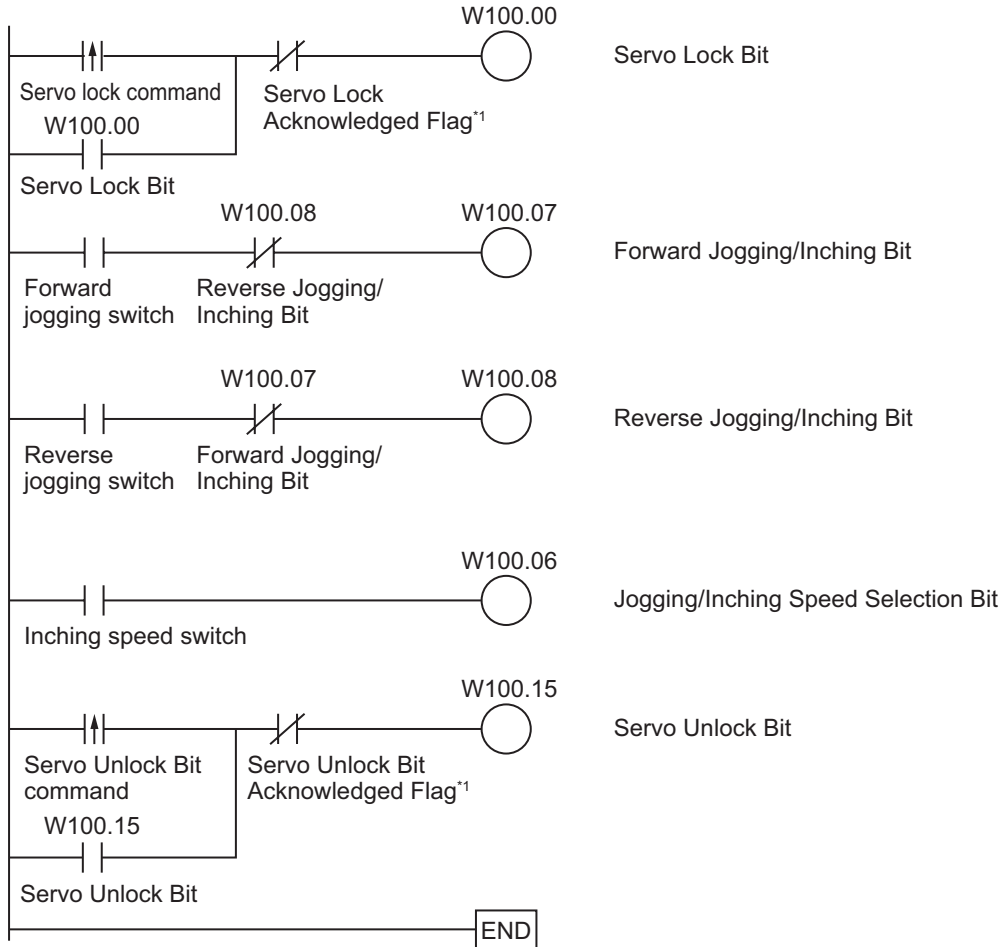

*1. When locking and unlocking the servo from the ladder program, keep the command bit ON until the Servo Lock Acknowledged Flag or Servo Unlock Acknowledged Flag turns ON in the Axis Status Memory Area.



Reference

- ♦ Other operations cannot be started while inching is being performed.

4-4 Operations with CX-Programmer

Manual operation on the CX-Programmer makes it possible to perform the following five operations.

- Jogging
- Inching
- Direct operation
- Origin searches
- Wiring checks

This section describes jogging, inching, and direct operation with the CX-Programmer.



Precautions for Correct Use

- When you perform jogging, direct operation, or origin searches from the CX-Programmer, the motor actually operates at the specified speed.
Before you execute any operation, thoroughly confirm the absence of any hazard that may be caused by motor operation.
- When you operate the PCU from the CX-Programmer, install an external emergency stop circuit or take other appropriate measures to safely stop the motor. The CX-Programmer may not be able to send commands under some circumstances, e.g., if an error occurs in the computer.
- Set the EtherCAT communications parameters and establish communications before attempting to perform manual operation from the CX-Programmer.
- Click the Save Button to save the settings in the axis parameters.
To perform origin searches from ladder programming using the parameters that you set in the Test Run Dialog Box, be sure to click the Save Button.

Opening the Test Run Dialog Box

1. In the PCU Setting Window, select Test Run from the NC Unit Menu.

When the following caution dialog box appears, read the message carefully. Click the OK Button only after you confirm that it is safe to start a test run.

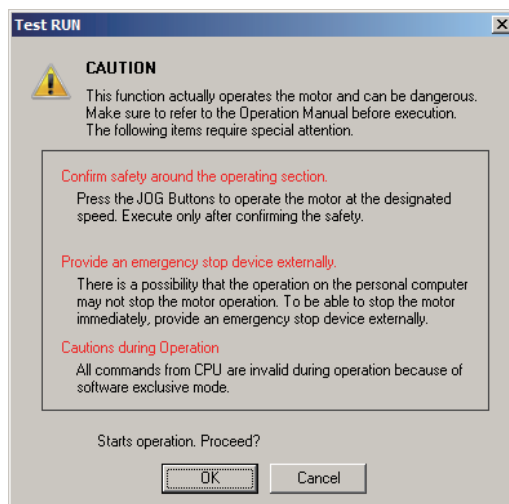



Precautions for Correct Use

- ♦ When you click the OK Button, the PCU will enter Support Software-controlled Operation Mode. Refer to *4-1 Outline of Manual Operation* page 4-1 for information on Support Software-controlled Operation Mode.

4

2. The Test Run Dialog Box will appear.

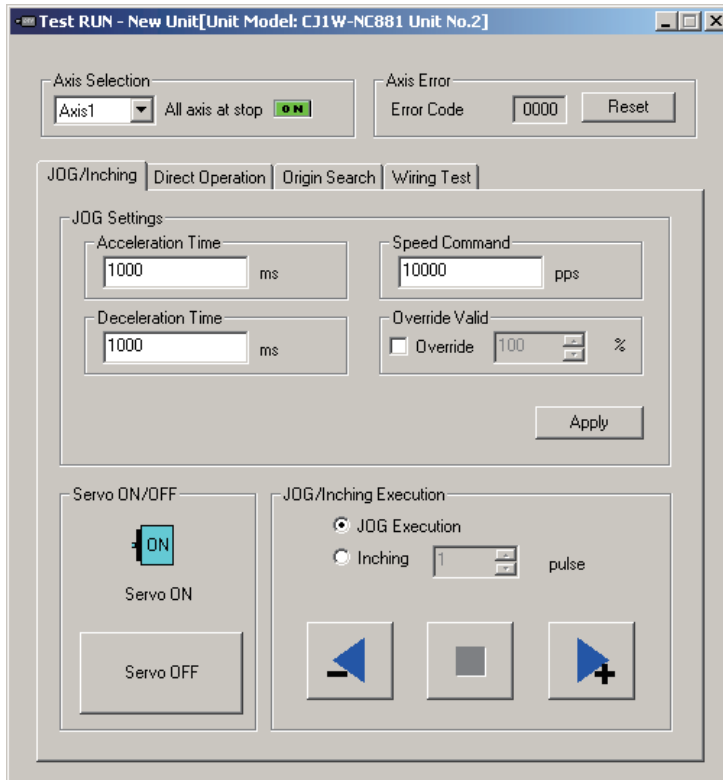

Procedure for Jogging/Inching

1. Click the JOG/Inching Tab in the Test Run Dialog Box.

The following dialog box will appear.

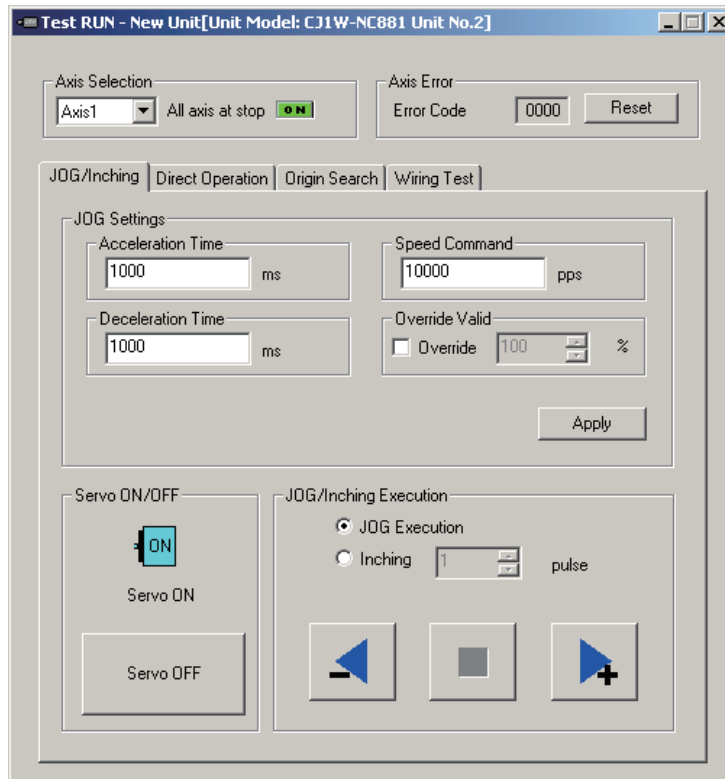

2. Select the axis you want to jog or inch.

3. Enter the acceleration time, deceleration time, speed command, and override for jogging/inching, and then click the Apply Button.

Be sure to click the Apply Button before you start jogging or inching.

4. Press the Servo ON Button. The servo will be locked.

5. Select the JOG Execution or Inching Option.

If you select inching, enter the inching width.

6. Execute the operation.

If you selected the JOG Execution Option, the axis will operate as long as you click the button.



Precautions for Correct Use

In Support Software-controlled Operation Mode, operation commands can be given only for one axis. Operation commands cannot be given simultaneously for more than one axis. Even if the axis selection in the Test Run Dialog Box is changed, the new axis cannot be operated while operation is in progress for another axis.

Procedure for Direct Operation

1. Click the **Direct Operation** Tab on the Test Run Dialog Box.

The following dialog box will appear.

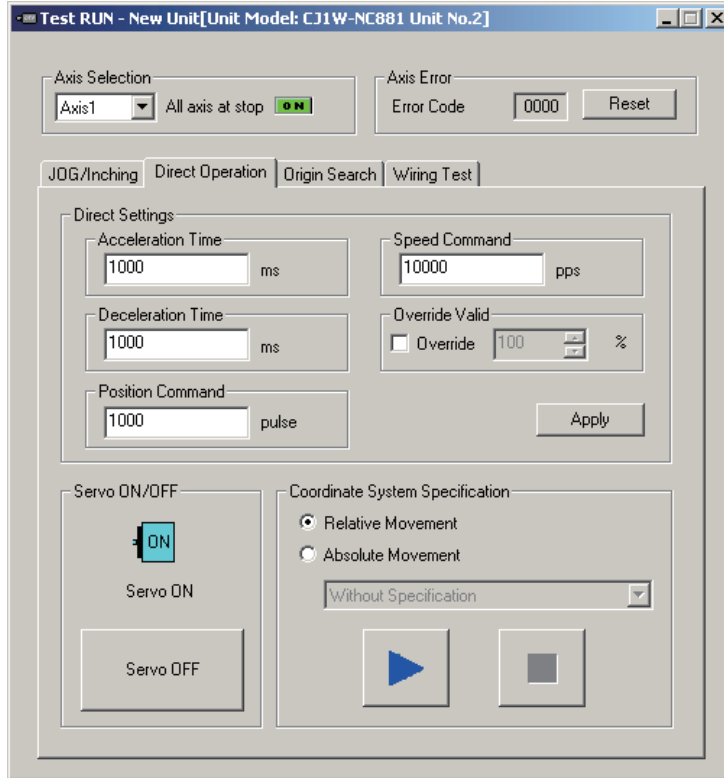

2. Select the axis for which you want to perform direct operation.
3. Enter the acceleration time, deceleration time, speed command, and position command, and then click the **Apply** Button.

Be sure to click the Apply Button before you start operation.

4. Press the **Servo ON** Button. The servo will be locked.
5. Select the **Absolute Movement** or **Relative Movement** Option.

Also, specify the operating direction if the axis feeding mode of the selected axis is set to Rotation Axis Mode and you want to perform an absolute movement.

6. Execute the operation.



Precautions for Correct Use

In Support Software-controlled Operation Mode, operation commands can be given only for one axis. Operation commands cannot be given simultaneously for more than one axis. Even if the axis selection in the Test Run Dialog Box is changed, the new axis cannot be operated while operation is in progress for another axis.

Defining the Origin

This section describes how to determine the origin, such as the origin search procedure as well as origin returns, present position presets and absolute encoder settings when the PCU is used in combination with an OMNUC G5-series Servo Drive.

5-1	Outline of Defining the Origin.....	5-1
5-2	Origin Search Procedure.....	5-3
5-3	Origin Search Operation	5-26
5-4	Present Position Preset.....	5-44
5-5	Origin Searches with CX-Programmer.....	5-46
5-6	Absolute Encoder Origin Setting	5-49
5-7	Origin Return Bit.....	5-54

5-1 Outline of Defining the Origin

This section describes the operations that are performed in combination with an OMNUC G5-series Servo Drive.

To position to absolute positions in a positioning system, you must first define the origin.

For example, if you want to perform positioning to the position (axis 1, axis 2) = (100 mm, 200 mm) in the XY plane shown below, you must determine the mechanical origin (0, 0).

This process of determining the mechanical origin is called defining the origin.

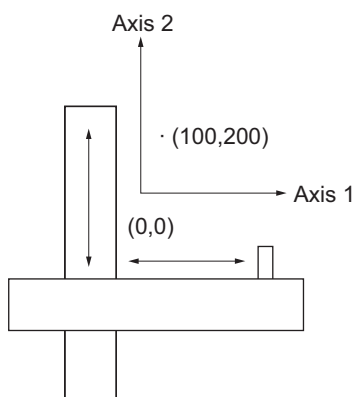

The Position Control Unit (PCU) has two functions that can be used to define the mechanical origin. These are listed in the following table.

Name	Description
Origin search	The origin is defined by actually moving the motor and using the limit sensors, origin proximity sensor, and origin input signal to determine the origin. Use a proximity sensor or the encoder's phase Z signal as the origin input signal.
Present position preset	The position where the Servomotor is currently stopped can be set to any specified position to define the origin. The PCU supports three present position preset functions. For details, refer to <i>5-4 Present Position Preset</i> on page 5-44.

Also, the origin return operation described in the following table can be used to return to the origin that was defined by using one of the above methods.

Name	Description
Origin return	Positioning is performed from the position where the motor is currently stopped to the origin that was defined by an origin search or present position preset.

With the PCU, you can operate the Servomotor even when the origin is not yet defined (except that origin return operations are not possible).

Operation will be performed as described in the following table when the origin is not defined.

Function		Operation
Jogging, inching, and speed control		If the origin is not defined, the position at startup is defined as 0 to control movement.
Origin return		Origin returns are not possible. If you attempt to perform an origin return, a present position unknown error (error code: 6006) will occur.
Direct operation	Absolute movements	If the origin is not defined, the position at startup is defined as 0 to control movement.
	Relative movements	
	Interrupt feeding	
Memory operation		Although you can combine the above speed control, absolute movement, relative movement, and interrupt feeding operations to operate the machine, the position at startup is defined as 0 to control movement if the origin is not defined.



Precautions for Correct Use

The forward drive prohibit input (POT), reverse drive prohibit input (NOT) and origin proximity input (DEC) assigned to external inputs of the Servo Drive are used for the PCU as the Forward Limit Input Flag, Reverse Forward Limit Input Flag, and Origin Proximity Input Flag. Make sure that the signal widths for all of these input signals are longer than the control cycle of the PCU. If the input signal widths are shorter than the control cycle, the PCU may not be able to detect the input signals, resulting in incorrect operation.



Reference

If an origin search is performed for an axis that is being used as a virtual axis, revolution for the axis will continue once the origin search is started. This is because the origin cannot be defined because there is no origin input, origin proximity sensor input, or other external input signals. A present position preset can be used to define the origin for virtual axes.

5-2 Origin Search Procedure

This section describes how to set data to perform an origin search. This example is for axis 1.

1. Common Parameter Settings

To perform an origin search, set the Manual Operation Command Memory Area and Axis Status Memory Area parameters.

2. Axis Parameter Settings

Set the following axis parameters: Maximum Speed, Origin Search Speed, Origin Search Approach Speed, Origin Search Acceleration Time, Origin Search Deceleration Time, etc.

3. Data Transfer

Transfer the common parameters and axis parameters to the PCU.

4. Restarting the PCU

Restart the PCU to enable the transferred parameters.

5. Put the Servo Drive in operating status.

6. Executing the Origin Search

Turn ON the Origin Search Bit to perform the origin search.

Common Parameter Settings

Set the Manual Operation Command Memory Area and Axis Status Memory Area common parameters.

1. Start the CX-Programmer.

2. Connect the CX-Programmer online to the PLC.

After the CX-Programmer is connected, change the CPU Unit to PROGRAM mode.

3. Double-click IO Table and Unit Setup in the project tree of the CX-Programmer.

The IO Table Window will appear for a new PLC.

4. In the IO Table Window for the PLC, double-click the PCU.

The PCU Setting Window will appear.

5. Click Common Parameter on the project tree in the PCU Setting Window.

The window for setting common parameters will appear.

6. Select Operation Memory Area Allocation Setting in the Parameter Type Box.

7. Select the Manual Operation Command Memory Area Selection parameter.

Select one of the five areas: CIO Area, WR Area, HR Area, DM Area, and EM Area (5## = EM bank number).

8. Enter the address for the First Word of Manual Operation Command Memory Area parameter.

9. Select the Axis Status Memory Area Selection parameter.

Select one of the five areas: CIO Area, WR Area, HR Area, DM Area, and EM Area (5## = EM bank number).

10. Enter the address for the First Word of Axis Status Memory Area parameter.

11. Execute automatic network setup by selecting Network Auto Setup from the Network Menu on the menu bar.

Executing this command will automatically set up communications for EtherCAT.

Manual Operation Command Memory Area

The following table lists the memory allocations when you set the First Word of Manual Operation Command Memory Area parameter to word "A."

Words	Name	Bit	Bit name	Function
A	Axis 1 Manual Operation Command Bits	0	Servo Lock Bit	Turn ON this bit to lock the servo.
		5	Override Enable Bit	Specify whether to enable or disable an override.
		6	Jogging/Inching Speed Selection Bit	Select the jogging/inching speed. Turn OFF this bit to select speed 1 and turn ON this bit to select speed 2.
		7	Forward Jogging/Inching Bit	Turn ON this bit to perform jogging or inching in the forward direction.
		8	Reverse Jogging/Inching Bit	Turn ON this bit to perform jogging or inching in the reverse direction.
		9	Not used.	Do not use this bit.
		10	Origin Search Bit	Turn ON this bit to start an origin search.
		11	Origin Return Bit	Turn ON this bit to start an origin return.
		12	Not used.	Do not use this bit.
		13	Immediate Stop Bit	Turn ON this bit to start performing an immediate stop.
		14	Deceleration Stop Bit	Turn ON this bit to start performing a deceleration stop.
		15	Servo Unlock Bit	Turn ON this bit to unlock the servo.
A+1	Axis 1 Override	0 to 15	–	Set the override in hexadecimal. You can set any value from 1 to 50,000 (0001 to C350 hex), which correspond to 0.01% to 500.00%.

Direct Operation Memory Area

The first word in the Direct Operation Memory Area is B.

The following table lists the words and bits in the Direct Operation Memory Area that are necessary for defining the origin.

For details on the Direct Operation Memory Area, refer to *Direct Operation Command Memory Area* on page 6-91.

Words	Name	Bit	Bit name	Function
B	Axis 1 Direct Operation Command Memory Area	0	Absolute Movement Bit	Turn ON this bit to start an absolute positioning operation.
		1	Relative Movement Bit	Turn ON this bit to start a relative positioning operation.
		2	Speed Control Bit	Turn ON this bit to start speed control with position loop in the CSP mode.
		3 to 4	Not used.	Do not use this bit.
		5	Interrupt Feeding Specification Bit	Enable or disable interrupt feeding when the Absolute Movement Bit, Relative Movement Bit, or Speed Control Bit turns ON. ON: Enabled, OFF: Disabled
		6	Interrupt Input Mask/ Present Position Latch Enable Bit	Use this bit to enable the interrupt input mask for interrupt feeding and enable the present position latch for the interrupt input. ON: Enabled, OFF: Disabled
		7	Present Position Preset Bit	Turn ON this bit to preset the present position.
		8	Synchronous Feeding Position Bit *1	While this bit is ON, the unit performs synchronous feeding position control.
		9	Synchronous Feeding Velocity Bit *1	While this bit is ON, the unit performs speed control and synchronous feeding velocity control without position loop in the CSV mode.
		10	Synchronous Feeding Torque Bit *1	While this bit is ON, the unit performs synchronous feeding torque control.
		11	Origin Position Latch Enable Bit *1	Enables the origin position latch. ON: Enabled, OFF: Disabled
		12 to 13	Not used.	Do not use this bit.
		14	Origin Position Latch Clear Bit *1	Turn this bit ON to clear the Origin Position Latch Completed Flag.
		15	Latch Completed Flag Clear Bit	Turn this bit ON to clear the Latch Completed Flag.
B+1	Axis 1 Rotation Axis Direction	0 to 15	Specify the operating direction to be applied when you execute an absolute movement for an infinite axis. 0: Shortest route 1: Forward 2: Reverse 3: Not specified	

Words	Name	Bit	Bit name	Function
B+2	Axis 1 Command Position (lower word)	0 to 15		Specify the position to be used in direct operation or present position preset.
B+3	Axis 1 Command Position (upper word)	0 to 15		Set the value in command units in hexadecimal. Setting range: 8000 0000 to 7FFF FFFF hex (-2,147,483,648 to 2,147,483,647 command units)
B+4	Axis 1 Command Speed (lower word)	0 to 15		Specify the target speed to be used in direct operation. Set the value in command units/s in hexadecimal.
B+5	Axis 1 Command Speed (upper word)	0 to 15		Setting Ranges: Position control: 1 to 7FFF FFFF hex (1 to 2,147,483,647 command units/s) Speed control: 8000 0000 to 7FFF FFFF hex (-2,147,483,648 to 2,147,483,647 command units/s)
B+6	Axis 1 Option Input 1 ^{*1}	0 to 15		Forward torque limit data. ^{*2} Specify the torque limit value when the forward torque limit is enabled. Setting range: 0 to 2710 hex (0 to 10000[0.1%]) Set the value in 0.1%.
B+7	Axis 1 Option Input 2 ^{*1}	0 to 15		Reverse torque limit data. ^{*3} Specify the torque limit value when the reverse torque limit is enabled. Setting range: 0 to 2710 hex (0 to 10000[0.1%]) Set the value in 0.1%.
B+8	Axis 1 Acceleration Time (lower word) ^{*4}	0 to 15		Specify the acceleration time. Set the value in ms in hexadecimal.
B+9	Axis 1 Acceleration Time (upper word) ^{*4}	0 to 15		Setting range: 0 to 3D090 hex (0 to 250,000 ms)
B+10	Axis 1 Deceleration Time (lower word) ^{*4}	0 to 15		Specify the deceleration time. Set the value in ms in hexadecimal.
B+11	Axis 1 Deceleration Time (upper word) ^{*4}	0 to 15		Setting range: 0 to 3D090 hex (0 to 250,000 ms)

*1. Available with version 1.3 or later PCUs.

*2. Available only when the positive torque limit value (60E0h) is mapped.

*3. Available only when the reverse torque limit value (60E1h) is mapped.

*4. The setting of the Acceleration/Deceleration Time Selection parameter determines the operation of the acceleration and deceleration times. For information on the Acceleration/Deceleration Time Selection parameter, refer to *Acceleration/Deceleration Settings* on page 6-36 and *Acceleration/Deceleration Time Selection* on page 6-38.

Axis Status Memory Area

The first word in the Axis Status Memory Area is C.

The following table lists the words and bits in the Axis Status Memory Area that are necessary for defining the origin.

For details on the Axis Status Memory Areas, refer to *Axis Status Memory Area* on page 6-100.

Words	Name	Bit	Bit name	Function
C	Axis 1 Manual Operation Command Acknowledged Flags	0	Servo Lock Acknowledged Flag	This flag turns ON to acknowledge the Servo Lock Bit.
		1	Drive Alarm Reset Acknowledged Flag	This flag turns ON to acknowledge the Drive Alarm Reset Bit.
		2	Deviation Counter Reset Acknowledged Flag	This flag turns ON to acknowledge the Deviation Counter Reset Bit.
		3	Forward Torque Limit Acknowledged Flag	This flag turns ON to acknowledge the Forward Torque Limit Bit.
		4	Reverse Torque Limit Acknowledged Flag	This flag turns ON to acknowledge the Reverse Torque Limit Bit.
		5	Override Enable Acknowledged Flag	This flag turns ON to acknowledge the Override Enable Bit.
		6	Jogging/Inching Speed Selection Acknowledged Flag	This flag turns ON to acknowledge the Jogging/Inching Speed Selection Bit.
		7	Forward Jogging/Inching Acknowledged Flag	This flag turns ON to acknowledge the Forward Jogging/Inching Bit.
		8	Reverse Jogging/Inching Acknowledged Flag	This flag turns ON to acknowledge the Reverse Jogging/Inching Bit.
		9	Not used.	Do not use this bit.
		10	Origin Search Acknowledged Flag	This flag turns ON to acknowledge the Origin Search Bit.
		11	Origin Return Acknowledged Flag	This flag turns ON to acknowledge the Origin Return Bit.
		12	Not used.	Do not use this bit.
		13	Immediate Stop Acknowledged Flag	This flag turns ON to acknowledge the Immediate Stop Bit.
		14	Deceleration Stop Acknowledged Flag	This flag turns ON to acknowledge the Deceleration Stop Bit.
15	Servo Unlock Acknowledged Flag	This flag turns ON to acknowledge the Servo Unlock Bit.		

Words	Name	Bit	Bit name	Function
C+1	Axis 1 Direct Operation Command Acknowledged Flags	0	Absolute Movement Acknowledged Flag	This flag turns ON to acknowledge the Absolute Movement Bit.
		1	Relative Movement Acknowledged Flag	This flag turns ON to acknowledge the Relative Movement Bit.
		2	Speed Control Acknowledged Flag	This flag turns ON to acknowledge the Speed Control Bit.
		3 to 4	Not used.	Do not use this bit.
		5	Interrupt Feeding Specification Acknowledged Flag	This flag turns ON to acknowledge the Interrupt Feeding Specification Bit.
		6	Interrupt Input Mask/Present Position Latch Enable Acknowledged Flag	This flag turns ON to acknowledge the Interrupt Input Mask/Present Position Latch Enable Bit.
		7	Present Position Preset Acknowledged Flag	This flag turns ON to acknowledge the Present Position Preset Bit.
		8	Synchronous Feeding Position Acknowledged Flag *1	This flag turns ON to acknowledge the Synchronous Feeding Position Bit.
		9	Synchronous Feeding Velocity Acknowledged Flag *1	This flag turns ON to acknowledge the Synchronous Feeding Velocity Bit.
		10	Synchronous Feeding Torque Acknowledged Flag *1	This flag turns ON to acknowledge the Synchronous Feeding Torque Bit.
		11	Origin Position Latch Enable Acknowledged Flag *1	This flag turns ON to acknowledge the Origin Position Latch Enable Bit.
		12 to 13	Not used.	Do not use this bit.
		14	Origin Position Latch Clear Acknowledged Flag *1	This flag turns ON to acknowledge the Origin Position Latch Completed Flag Clear Bit.
15	Latch Completed Flag Clear Acknowledged Flag	This flag turns ON to acknowledge the Latch Completed Flag Clear Bit.		

5-2 Origin Search Procedure

Words	Name	Bit	Bit name	Function
C+2	Axis 1 Command Status	0	Axis Busy Flag	This flag turns ON during axis operation. During memory operation, the Busy Flags for axes that are not assigned in the axis configuration will turn ON even if there is no axis operation.
		1	Jogging Enabled Flag	This flag turns ON when jogging can be started.
		2	Direct Operation Enabled Flag	This flag turns ON when direct operation can be started.
		3	Not used.	Do not use this bit.
		4	Stop Input Flag	This flag will turn ON when the Immediate Stop Bit or the Deceleration Stop Bit is acknowledged or when the emergency stop input or deceleration input is received. Other start command bits will not be acknowledged while this flag is ON.
		5	Synchronous Group Stop Input Flag* ¹	This flag turns ON when the Synchronous Group Stop Bit in synchronized data is acknowledged and the system is stopped and when the Synchronous Group Stop Bit is ON.
		6	All Synchronized Unit Stop Input Flag* ¹	This flag turns ON when the All Synchronized Unit Stop Bit in synchronized data is acknowledged and the system is stopped and when the All Synchronized Unit Stop Bit is ON.
		7	High-speed PTP Start Acknowledged Flag	This flag turns ON to acknowledge a high-speed PTP start.
		8	Start Invalid Flag	This flag turns ON after the executed command has failed because it does not meet the conditions for starting the applicable function. This status is set when an operation cannot be started due to an error that occurs at the start of the command or because of the priority of the command.
		9	Deviation Counter Reset Acknowledged Flag	This flag turns ON if the Deviation Counter Reset Bit is not acknowledged after the Deviation Counter Reset Bit is output during an origin search operation.
		10 to 11	Not used.	Do not use this bit.
		12	Stop Executed Flag	This flag turns ON when axis operation has stopped for one of the following reasons during manual operation or direct operation. <ul style="list-style-type: none"> ♦ Stopping when a deceleration stop is executed, the deviation counter is reset, or the servo is unlocked ♦ Stopping when an error occurs
13	Positioning Operation Completed Flag	This flag turns ON when positioning, an origin search, or an origin return has been finished in direct operation or when jogging is stopped in direct operation.		
14 to 15	Not used.	Do not use this bit.		

Words	Name	Bit	Bit name	Function
C+3	Axis 1 Axis Operation Command Status	0	While servo is unlocked	This flag is ON while the servo is unlocked for the axis.
		1	Servo Locked Flag	This flag is ON when the axis is stopped in servo lock status.
		2	Not used.	Do not use this bit.
		3	Acceleration Flag	This flag is ON while the axis is accelerating to the target speed. This flag can also be used for path status during interpolation.
		4	Constant Speed Flag	This flag is ON while the axis is moving at a constant speed after reaching the target speed. This flag can also be used for path status during interpolation.
		5	Deceleration Flag	This flag is ON while the axis is decelerating to the target position or to the target speed. This flag can also be used for path status during interpolation.
		6	Pass Flag	This flag is ON during acceleration/ deceleration to the target speed of the next sequence for the continuous 1 or continuous 3 operation patterns. This flag can also be used for path status during interpolation.
		7	Positioning Completed Waiting Flag	This flag is ON while waiting for axis positioning to be completed. This flag can also be used for path status during interpolation.
		8	Deceleration Stop Flag	This flag is ON until the axis stops for a deceleration stop during axis operation.
		9	Immediate Stop Flag	This flag is ON until the axis stops for an immediate stop during axis operation.
10 to 15	Not used.	Do not use this bit.		

5-2 Origin Search Procedure

Words	Name	Bit	Bit name	Function
C+4	Axis 1 Operation Status	0	Origin Search Flag	This flag is ON during an origin search operation.
		1	Origin Return Flag	This flag is ON during an origin return operation.
		2	Not used.	Do not use this bit.
		3	Jogging/Inching Flag	This flag is on during jogging or inching.
		4	Absolute Movement Flag	This flag is ON during a absolute movement. It is also ON until the interrupt feeding input is received.
		5	Relative Movement Flag	This flag is ON during a relative movement. It is also ON until the interrupt feeding input is received.
		6	Speed Control Flag	This flag is ON during speed control. It is also ON until the interrupt feeding input is received.
		7	Interrupt Feeding (Interrupt Input Waiting) Flag	This flag is ON during interrupt feeding until the interrupt input turns ON.
		8	Interrupt Feeding (Positioning) Flag	This flag is ON after the interrupt input turns ON during interrupt feeding.
		9 to 10	Not used.	Do not use this bit.
		11	Memory Operation Flag	This flag is ON during memory operation.
		12	Not used.	Do not use this bit.
		13	Synchronous Feeding Torque Flag ^{*1}	This flag is ON during a synchronous feeding torque operation. The axis movement reflects the command torque data stored in the Synchronous Data Link Area.
		14	Synchronous Feeding Velocity Flag ^{*1}	This flag is ON during a synchronous feeding velocity operation. The axis movement reflects the command speed data stored in the Synchronous Data Link Area.
15	Synchronous Feeding Position Flag ^{*1}	This flag is ON during a synchronous feeding position operation. The axis movement reflects the position data for the auxiliary axis set in the Electric Shaft and Synchronous Data Link Area.		

Words	Name	Bit	Bit name	Function
C+5	Axis 1 Control Status	0	Origin Defined Flag	This flag is ON while the origin is defined. OFF: Origin not defined. ON: Origin defined.
		1	Stopped at Origin Flag	This flag is ON while the axis is stopped within the positioning completed width. It will not turn ON unless the origin is defined.
		2	Latch Completed Flag	This flag turns ON when the present position has been latched.
		3	Origin Position Latch Completed Flag ^{*1}	This flag turns ON when the present origin position has been latched.
		4	Command Present Position Overflow Flag	This flag turns ON when an overflow occurs in the command position in Linear Mode.
		5	Command Present Position Underflow Flag	This flag turns ON when an underflow occurs in the command position in Linear Mode.
		6	Feedback Present Position Overflow Flag	This flag turns ON when an overflow occurs in the feedback position in Linear Mode.
		7	Feedback Present Position Underflow Flag	This flag turns ON when an underflow occurs in the feedback position in Linear Mode.
		8	Sensor Error Flag	This flag turns ON when an error is detected for an external sensor, such as for the emergency stop input or a limit input.
		9	Servo Error Flag	This flag turns ON when a servo drive alarm occurs.
		10	Execution Error Flag	This flag turns ON when an attempt to execute a command associated with an axis function has failed with a multi-start or similar error due to an invalid execution condition or command value.
		11	Axis Warning Flag	This flag turns ON when a warning occurs in memory operation.
		12	Axis Error Flag	This flag turns ON when an axis error occurs.
		13	Zone 0 Flag	This flag is ON while the present position is in zone 0.
		14	Zone 1 Flag	This flag is ON while the present position is in zone 1.
15	Zone 2 Flag	This flag is ON while the present position is in zone 2.		

5-2 Origin Search Procedure

Words	Name	Bit	Bit name	Function
C+6	Axis 1 External I/O Status	0	Servo ON Flag	This flag is ON while power is being supplied to the Servomotor.
		1	Alarm Reset Output Flag	This flag turns ON when an alarm reset is output.
		2	Deviation Counter Reset Output Flag	This flag turns ON when a deviation counter reset is output.
		3	Forward Torque Limit Output Flag	This flag turns ON when a forward torque limit is output.
		4	Reverse Torque Limit Output Flag	This flag turns ON when a reverse torque limit is output.
		5	Main Circuit Status Flag	This flag turns ON when a voltage is supplied to the main circuits.
		6	Servo Drive Warning Input Flag	This flag turns ON when a Servo Drive warning occurs.
		7	Servo Ready Flag	This flag turns ON when the servo is ready.
		8	Forward Limit Input Flag	This flag is ON while the forward limit input is being received.
		9	Reverse Limit Input Flag	This flag is ON while the reverse limit input is being received.
		10	Origin Proximity Input Flag	This flag is ON while the origin proximity input is being received.
		11	Origin Input Flag	This flag is ON while the origin input is being received.
		12	Interrupt Input Flag	This flag is ON while the interrupt input is being received.
		13	Emergency Stop Input Flag	This flag is ON while the emergency input is being received.
		14	Positioning Completed Input Flag	This flag is ON while the axis is within the positioning completed width.
15	Drive Alarm Input Flag	This flag turns ON when a drive alarm occurs.		
C+7	Axis 1 Error Code	0 to 15	This word contains the axis error code.	
C+8	Axis 1 Command Present Position (lower word)	0 to 15	These words contain the present command position.	
C+9	Axis 1 Command Present Position (upper word)			
C+10	Axis 1 Expanded Monitor (lower word)	0 to 15	These words contain the monitor value that is specified by the Expanded Monitor Type axis parameter. For details, refer to <i>Expanded Monitor Settings</i> on page 6-59.	
C+11	Axis 1 Expanded Monitor (upper word)			
C+12	Not used.	0 to 15	Do not use this bit.	

*1. Available with version 1.3 or later PCUs.

Axis Parameter Settings

This section describes the minimum axis parameters that are necessary for Origin Search.

1. **Click Axis Parameter in the project tree in the PCU Setting Window.**
The window for setting the axis parameters will appear.
2. **Select Axis Type Setting in the Parameter Type Box.**
Select Physical Axis for the axes that are connected to Servo Drives.
Select Unused Axis for any unused axes. An error will not be displayed even if you do not wire an axis that is set as an unused axis.
3. **Select Command Position Unit Setting in the Parameter Type Box.**
Set the Axis Feeding Mode, Rotation Axis Upper Limit, Displayed Unit, Command Pulse Count Per Motor Rotation, Work Travel Distance Per Motor Rotation, and Unit Multiplier parameters.
4. **Select IO Function Setting in the Parameter Type Box.**
Select the input types for the connected sensors.
Set the Origin Proximity Input Signal Selection and Origin Input Signal Selection parameters.
5. **Select Acceleration/Deceleration Setting in the Parameter Type Box.**
Set the Maximum Speed, Acceleration/Deceleration Curve Selection and Acceleration/Deceleration Time Selection parameters.
6. **Select Output Setting in the Parameter Type Box.**
Set the Output Direction parameter.
7. **Select Software Limit Setting in the Parameter Type Box.**
Set the Software Limit Function Selection, Reverse Software Limit, and Forward Software Limit parameters.
8. **Select Origin Search Setting in the Parameter Type Box.**
Set the Origin Search Operation Mode, Operation at Forward Limit Input, Operation at Reverse Limit Input, Origin Search Start Direction, Origin Input Detection Direction, Origin Search Holding Time, Origin Input Mask Amount, Origin Compensation Value, Origin Position Offset, Origin Search Speed, Origin Search Approach Speed, Origin Search Compensation Speed, Origin Search Acceleration Time, and Origin Search Deceleration Time parameters.



Reference

- ♦ Set other parameters, such as Jogging/Inching Setting, Feedback Pulse Input Setting, Expanded Monitor Setting, and Deviation Monitor Function Setting parameters, if necessary.
- ♦ For details on axis parameters, refer to *6-4 Axis Parameters* on page 6-29.

Axis Type Setting

Parameter name	Function	Setting range	Unit	Default value
Axis Type *1	Select the axis type. 0: Physical axis 2: Unused axis	0 or 2	–	0

*1. I/O wiring is not required for axes that are set as unused axes.



Reference

- ♦ Select Physical Axis for axes that are actually wired to operate, and select Unused Axis for other axes.
- ♦ For information on how to set a virtual axis, refer to *Axis Type Setting* on page 6-32.

Command Position Unit Setting

Parameter name	Function	Setting range	Unit	Default value
Axis Feeding Mode	Select the counting mode for the command position. 0: Linear axis (finite length), 1: Rotation axis (infinite length)	0 to 1	–	0
Rotation Axis Upper Limit	Set the rotation axis upper limit when you set the Axis Feeding Mode to a rotation axis.	1 to 1,073,741,823*1	Command units	1,073,741,823
Displayed Unit	Select the unit for command values. 0: Pulses, 1: mm, 2: Degrees, 3: Inches	1 to 3	–	0
Command Pulses Count Per Motor Rotation	Set the number of pulses per motor rotation.	1 to 4,294,967,295*2	Pulses	10,000
Work Travel Distance Per Motor Rotation	Set the amount of workpiece movement per motor rotation.	1 to 4,294,967,295*2	Displayed Unit	10,000
Unit Multiplier	Set the ratio relative to the amount of the workpiece movement when the motor makes 1 rotation. 0: x1, 1: x10, 2: x100, 3: x1,000, 4: x10,000	0 to 4	–	0

*1. This setting range is for pulses.

*2. The setting range for PCUs of version 1.1 or earlier is 1 to 1,048,576.

Axis Feeding Mode

Linear Axis:

- ♦ A linear counter that counts from -2,147,483,648 to 2,147,483,647 centering around 0 will be used for this setting.
- ♦ In position control, a command for which the counter value overflows will cause an error and the command will not be executed.
- ♦ The above error will also occur when the interrupt input is received during interrupt feeding.
- ♦ In speed control, an overflow/underflow warning will occur when the present position overflows or underflows the counter value, but operation will continue. The counter value will be locked at the maximum value.
- ♦ While the counter value is locked, only jogging commands in the reverse direction will be acknowledged. A command to start any other operation will cause an error at start.
- ♦ The counter value will remain locked until you clear the overflow/underflow status.
- ♦ To clear the overflow/underflow status, you must perform an origin search or present position preset.
- ♦ The overflow/underflow values depend on the electronic gear setting.

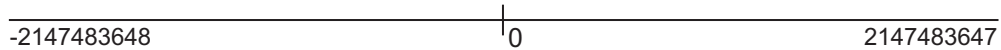

Rotation Axis:

- ♦ A ring counter with a maximum value of 1,073,741,823 is used (infinite axis).
- ♦ If 0 (shortest route), 1 (forward), or 2 (reverse) is specified as the Rotation Axis Direction for an absolute movement command, an error will occur if a command value exceeding the rotation axis upper limit is set. If 3 (not specified) is specified as the Rotation Axis Direction for an absolute movement command or if a relative movement command is used, multiple rotations will be supported if a command value that exceeds the rotation axis upper limit is set.

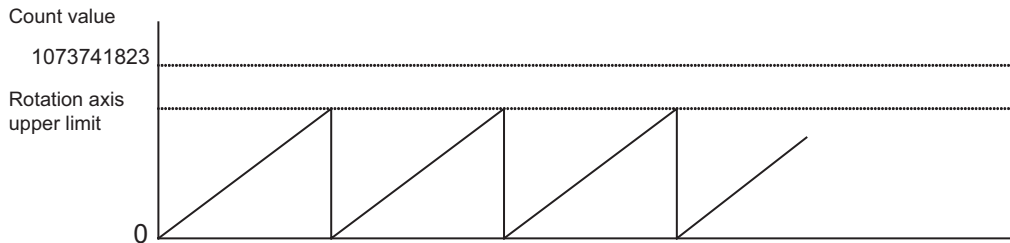

Rotation Axis Upper Limit

This parameter is valid when you set the Axis Feeding Mode parameter to specify a rotation axis.

Display Selection

Select the unit for commands.

Position data and other data will not be reconverted when you change the unit.

Command Pulse Count Per Motor Rotation

Set the number of encoder pulses per motor rotation.

Work Travel Distance Per Motor Rotation

Set the amount of the workpiece movement per motor rotation. This setting is an integer. Set Unit Multiplier parameter (below) if you want to set decimal places.

Unit Multiplier

Set the ratio relative to the amount of the workpiece movement when the motor makes 1 rotation.

Setting a Command Unit of 1mm

If the movement per motor rotation is 6 mm and you want to rotate the motor once with a command unit of 1 mm, set the Work Travel Distance Per Motor Rotation parameter to 6 and the Unit Multiplier parameter to 0 (x1). With these settings, the motor will rotate once for a position command of 6.

Setting a Command Unit of 0.01mm

If the movement per motor rotation is 6 mm and you want to rotate the motor once with a command unit of 0.01mm, set the Work Travel Distance Per Motor Rotation parameter to 6 and the Unit Multiplier parameter to 2 (x100). With these settings, the motor will rotate once for a position command of 600.



Precautions for Correct Use

If the Axis Feeding Mode parameter is set to Rotation Axis, set the pulse unit so that the number of pulses in one rotation can be divided evenly by the specified pulse unit.

Specifically, if the setting of the Rotation Axis Upper Limit parameter plus one (command units) is converted to pulses, the number of pulses must be an integer. If the number of pulses in one rotation is not an integer, the decimal portion will be truncated, causing a position offset. If there is a decimal portion, the command present value will not be displayed correctly.

I/O Function Settings

Parameter name	Function	Setting range	Unit	Default value
Origin Proximity Input Signal Selection* ¹	Select the input to use as the origin proximity input. 0: Use the Origin Proximity Input Internal Memory Area Bits as the origin proximity inputs. 1: Use an external origin proximity input.	0 to 1	–	1
Origin Input Signal Selection	Select the input to use as the origin input. 0: Use Z-phase input as the origin. 1: Use an external origin input.* ²	0 to 1	–	0
Interrupt Input Function* ³	Select the function of the interrupt input. 0: Use as an interrupt feeding trigger. 1: Use as a present position latch signal.	0 to 1	–	0
Limit Input Stop Method* ³	Select the function to be implemented when a forward/reverse limit signal is input. 0: Immediately stops reference output. 1: Deceleration stop of reference output 2: Immediate stop of reference output, and deviation counter reset 3: Immediate stop of reference output, deviation counter reset, and servo unlocked. 4: Immediate stop of reference output, and servo unlocked	0 to 4	–	0
Drive Alarm Reset Output Time* ³	Set the automatic output time when the Drive Alarm Reset Bit is turned ON (when resetting errors).	1 to 1,000	ms	200
Positioning Monitoring Time* ³	Set the monitoring time when the positioning completed signal is enabled. If you set 0 ms, the positioning completed signal is not monitored. The PCU will continue to wait for a positioning completed input after the origin input is detected during an origin search. The PCU will also not monitor the positioning completed input for the origin compensation operation. If you set any value other than 0, an error will occur if the specified time is exceeded.	1 to 10,000	ms	0

*1. If the Origin Proximity Input Signal Selection parameter is set to 0, Origin Proximity Input Internal Memory Area Bits 00 to 15 will correspond to the origin proximity inputs for axes 1 to 16. This setting is disabled for virtual axes.

*2. When using an OMNUC G5-series Servo Drive, the external origin input is allocated to latch 1 of the Servo Drive. The allocation of latch 1 can be changed using a servo parameter object in the Servo Drive. Refer to *OMNUC G5-series AC Servomotors/Servo Drives with Built-in EtherCAT Communications User's Manual* (Cat. No. I573) for details.

*3. These parameters are disabled for virtual axes and will be ignored.

Acceleration/Deceleration Settings

Parameter name	Function	Setting range	Unit	Default value
Maximum Speed	Specify the maximum speed for the axis.	1 to 2,147,483,647*1	Command units/s	4,000,000
Starting Speed	Specify the starting speed for the axis.	1 to 2,147,483,647*1	Command units/s	0
Operation at Reverse Rotation Command*2	Select the operation for reversing rotation for multi-starting. 0: Deceleration stop for reverse rotation, 1: Immediate stop for reverse rotation	0 to 1	—	0
Acceleration/Deceleration Curve Selection	Select the acceleration/deceleration curve. 0: Trapezoid, 1: S-curve (tertiary curve)y	0 to 1	—	0
Acceleration/Deceleration Time Selection	Set how to specify the acceleration/deceleration time. 0: Time from starting speed to maximum speed of each axis (constant acceleration/deceleration rate) 1: Time from present speed to target speed of each axis (constant acceleration/deceleration time)	0 to 1	—	0
Single Axis Deceleration Time at Interpolation*2	Set the deceleration stop time to be applied when an error occurs in any of the interpolated axes or an individual deceleration stop is executed during interpolation operation in memory operation.	0 to 250,000	ms	1,000

*1. The maximum speed is 104,857,600 pps when converted to pulses.

*2. This parameter is not necessary for origin searches. For details, refer to *Acceleration/Deceleration Settings* on page 6-36.

Maximum Speed

Set the fastest speed to actually use. This prevents you from inadvertently using speeds exceeding the maximum speed.

The maximum setting is 2147483647, but the upper limit of the setting when converted to pulses is 104,857,500 pps.

Starting Speed

If you use a Servomotor, set this parameter to 0.

Acceleration/Deceleration Curve Selection

Select the acceleration/deceleration curve.

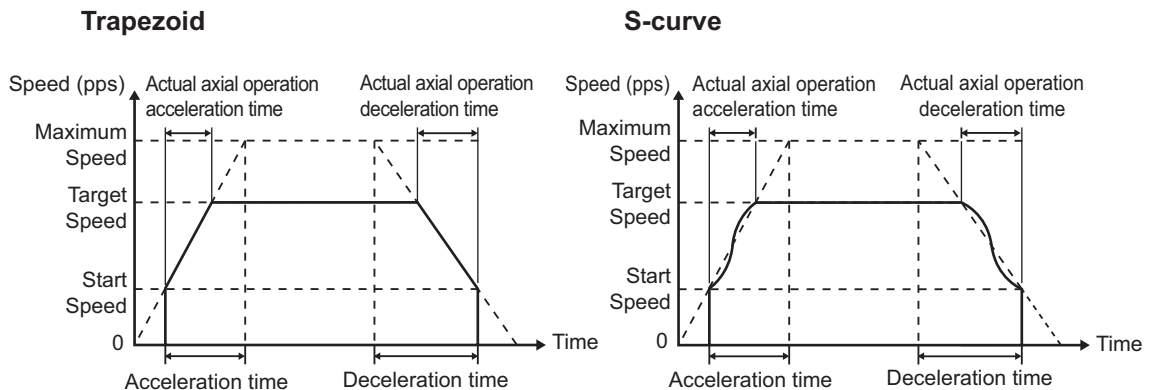

Acceleration/Deceleration Time Selection

Select the method for the acceleration/deceleration time designation method. You can specify a constant acceleration/deceleration rate or a constant acceleration/deceleration time.

With a constant acceleration/deceleration rate, the acceleration/deceleration time is the time from the starting speed to the maximum speed. With this setting, the acceleration/deceleration time changes according to the target speed.

With a constant acceleration/deceleration time, the acceleration/deceleration time is the time from the present speed to the target speed. With this setting, the acceleration/deceleration time will not change. For triangle control, however, the acceleration/deceleration time is based on the acceleration that is calculated from the present speed, target speed, and acceleration/deceleration time.

Constant Acceleration Rate

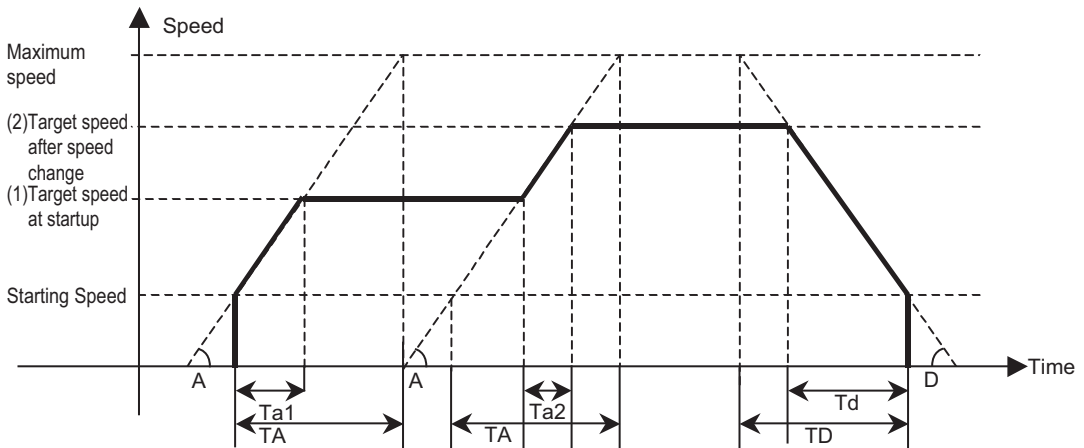

At Startup

TA: Acceleration time
Ta1: Actual acceleration time
A: Acceleration rate

For Speed Changes

TA: Acceleration time
Ta2: Actual acceleration time
A: Acceleration rate

During Deceleration

TD: Deceleration time
Td: Actual deceleration time
D: Rate of deceleration

Constant Acceleration/Deceleration Time

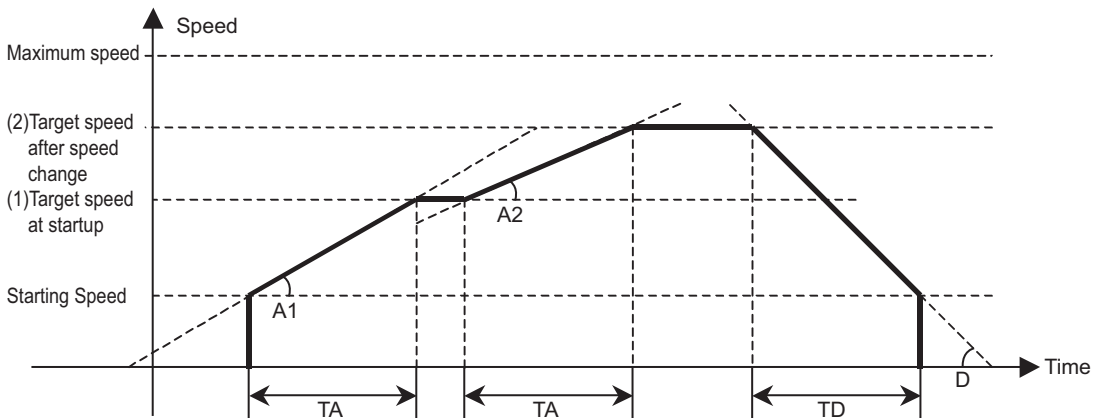

At Startup

TA: Acceleration time
A1: Acceleration rate

For Speed Changes

TA: Acceleration time
A2: Acceleration rate

During Deceleration

TD: Deceleration time
D: Rate of deceleration



Reference

- A constant acceleration/deceleration rate is always used for origin searches regardless of the setting of the Acceleration/Deceleration Time Selection parameter.

Output Settings

Parameter name	Function	Setting range	Unit	Default value
Output Direction ^{*1}	Set the rotation direction of the Servomotor. 0: Forward rotation for positive command values 1: Reverse rotation for positive command values	0 to 1	–	0

*1. With this parameter, you can switch the rotation direction of the motor without changing the wiring.

Output Direction

You can change the rotation direction of the motor without changing the wiring.

Software Limit Settings

Parameter name	Function	Setting range	Unit	Default value
Software Limit Function Selection	Select the software limit function. 0: Disabled 1: Enabled for command positions. Disabled for adjustment operations. ^{*1} 2: Enabled for feedback positions. Disabled for adjustment operations. ^{*1} 3: Enabled for command positions and adjustment operations. ^{*1} 4: Enabled for feedback positions and adjustment operations. ^{*1}	0 to 4	–	0
Reverse Software Limit	Set the software limit value in the reverse direction.	-2,147,483,647 to 2,147,483,646 ^{*2}	Command units	-2,147,483,647
Forward Software Limit	Set the software limit value in the forward direction.	-2,147,483,647 to 2,147,483,646 ^{*2}	Command units	2,147,483,646

*1. Adjustment operations include jogging and inching.

*2. These setting ranges are for pulses.

Origin Search Settings

Parameter name	Function	Setting range	Unit	Default value
Origin Search Operation Mode	Select the method to define the origin. 0: Proximity reverse turn/origin proximity input OFF 1: Proximity reverse turn/origin proximity input ON 2: Proximity reverse turn/origin proximity input OFF (approach speed after reverse turn) 3: Proximity reverse turn/origin proximity input ON (approach speed after reverse turn) 4: Origin proximity input OFF 5: Origin proximity input ON 6: Origin reverse turn/no origin proximity input 7: No origin proximity input 8: Limit input OFF 9: Proximity reverse turn/origin input mask amount 10:Origin proximity input only 11:Proximity reverse turn/holding time 12:Proximity reverse turn/holding origin input 13:No origin proximity input/holding origin input 14:Origin preset	0 to 14	—	0
Operation at Forward Limit Input	Select the operation to be performed when the reverse limit input in the operating direction turns ON during an origin search. 0: No reverse turn, error stop *1 1: Reverse turn, deviation pulse stop 2: Reverse turn, deceleration stop	0 to 2	—	1
Operation at Reverse Limit Input	Select the operation to be performed when the reverse limit input in the operating direction turns ON during an origin search. 0: No reverse turn, error stop *1 1: Reverse turn, deviation pulse stop 2: Reverse turn, deceleration stop	0 to 2	—	1
Origin Search Start Direction	Select the starting direction for an origin search. 0: Forward, 1: Reverse	0 to 1	—	0
Origin Input Detection Direction	Select the origin input detection direction for an origin search. 0: Forward, 1: Reverse	0 to 1	—	0
Origin Search Holding Time	Set the holding time when you set the Origin Search Operation Mode to Proximity Reverse Turn/Holding Time.	0 to 10,000	ms	100

5-2 Origin Search Procedure

Parameter name	Function	Setting range	Unit	Default value
Origin Input Mask Amount	Set the feeding amount when you set the Origin Search Operation Mode to Proximity Reverse Turn/Origin Input Mask Amount.	0 to 2,147,483,647*2	Command units	10,000
Origin Compensation Value	Set the origin search compensation amount that is applied after the origin is determined.	-2,147,483,647 to 2,147,483,647*2	Command units	0
Origin Position Offset	Preset the present position for the value that is set after starting an origin search.	-2,147,483,647 to 2,147,483,647*2	Command units	0
Origin Search Speed	Set the high speed during an origin search.	1 to 2,147,483,647*2	Command units/s	10,000
Origin Search Approach Speed	Set the proximity speed during an origin search.	1 to 2,147,483,647*2	Command units/s	1,000
Origin Search Compensation Speed	Set the compensation speed during an origin search.	1 to 2,147,483,647*2	Command units/s	1,000
Origin Search Acceleration Time	Set the acceleration time during an origin search.	0 to 250,000	ms	1,000
Origin Search Deceleration Time	Set the deceleration time during an origin search.	0 to 250,000	ms	1,000

*1. The error stopping method depends on the limit input stopping method.

*2. These setting ranges are for pulses.

Origin Search Operation Mode

Select one of the fifteen operations to define the mechanical origin. For details, refer to *Origin Search Operations* on page 5-26.

Operation at Forward Limit Input and Operation at Reverse Limit Input

Select whether to reverse the axis and continue with the origin search, or to not reverse the axis, create an error, and stop the axis, when the axis reaches a limit input in the operating direction during an origin search. To reverse the axis, also select the stopping method.

An error will occur and operation will stop if you set reversing for the limit input operation in both directions and the origin cannot be detected after moving from the limit input position opposite to the origin input detection direction to the other limit input position.

Origin Search Start Direction

Select the direction in which the axis starts moving when an origin search is started. Refer to the following figure.

Origin Position Latch

The Origin Position Latch function is available when the PCU is set to the Origin Search Operation mode that uses the Origin Input Flag.

For details, refer to *10-8 Origin Position Latch* on page 10-31.

Origin Input Detection Direction

Select the direction for detecting the origin input. Refer to the following figure.

Origin Search Start Direction Same as Origin Input Detection Direction

Origin search start direction and origin input detecting direction

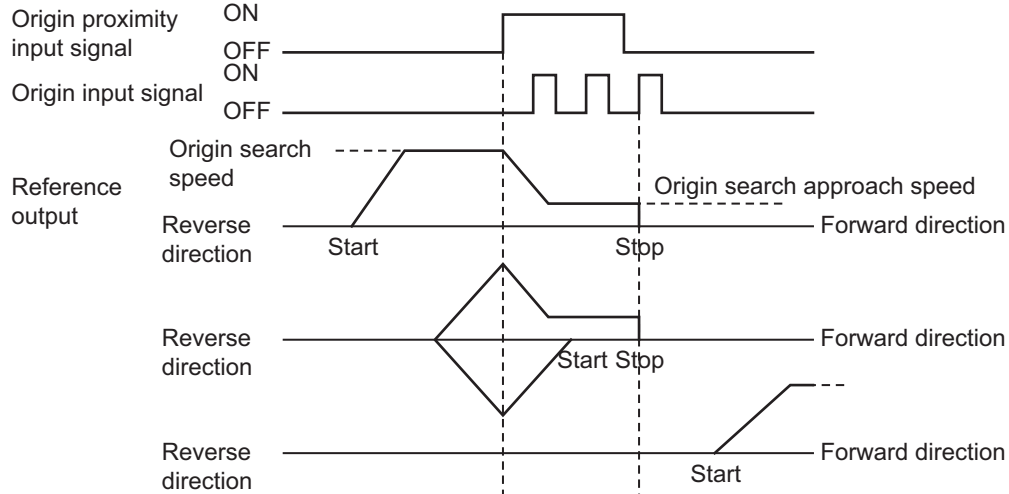

Origin Search Start Direction Different from Origin Input Detection Direction

Origin search start direction



Origin input detection direction

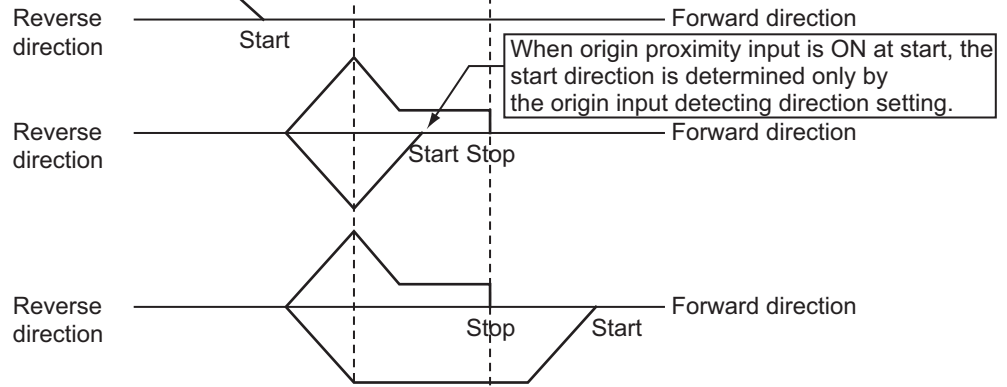

Origin Search Holding Time

Set the holding time when you set the Origin Search Operation Mode to Proximity Reverse Turn/Holding Time.

For details, refer to *Proximity Reverse Turn and Holding Time (Setting: 11)* on page 5-36.

Origin Input Mask Amount

Set the feeding amount when you set the Origin Search Operation Mode to Proximity Reverse Turn/Origin Input Mask Amount.

For details, refer to *Proximity Reverse Turn and Origin Input Mask Amount (Setting: 9)* on page 5-34.

Origin Compensation Value

Set the origin search compensation value that is applied after detecting the origin.
Set the applicable speed in the Origin Search Compensation Speed parameter.
For details, refer to *Origin Compensation* on page 5-40.

Origin Position Offset

The mechanical origin that is set by the origin search operation can be preset to a specified value.

This means that the mechanical origin can be set to any specified value rather than to 0.
The present value will be the value set for the Origin Position Offset parameter.

When using an absolute encoder system, the absolute encoder origin will be set at the same time.

For details on the absolute encoder origin setting, refer to *5-6 Absolute Encoder Origin Setting* on page 5-49.

Origin Search Speed

This is the high speed during an origin search.

Origin Search Approach Speed

This is the proximity speed during an origin search.

Origin Search Compensation Speed

This is the speed when you set an origin compensation value.
For details, refer to *Origin Compensation* on page 5-40.

Origin Search Acceleration Time and Origin Search Deceleration Time

Set the acceleration time and deceleration time to use during an origin search.
For details, refer to *Acceleration/Deceleration Settings* on page 5-19.

5-3 Origin Search Operation

The PCU supports fifteen Origin Search Operation Modes. You can also fine-tune the origin that is detected with an origin compensation value.



Reference

The most suitable mode depends on the configuration of the positioning system and the application.

With a linear axis (finite length), origin proximity sensor, forward limit input, and reverse limit input, setting 0 (Proximity Reverse Turn and Origin Proximity Input OFF) is normally used.

Origin Search Operations

This section describes the 15 Origin Search Operation Modes.



Precautions for Correct Use

Take this precaution when using an Origin Search Operation Mode that is based on the following automatic torque limit control functions:

- ◆ Proximity Reverse Turn and Holding Time (Setting: 11)
- ◆ Proximity Reverse Turn and Holding Origin Input (Setting: 12)
- ◆ No Origin Proximity Input and Holding Origin Input (Setting: 13)

If you intend to use the memory area allocations directly to change the torque limit data, be sure to set torque limit data in the Direct Operation Command Memory Area in advance. Otherwise, the torque will not be correctly generated.

Proximity Reverse Turn and Origin Proximity Input OFF (Setting: 0)

1. When the origin proximity sensor turns ON, the axis starts decelerating to the origin search approach speed.
2. After the axis reaches the origin search approach speed, the axis stops at the first origin input signal after the origin proximity sensor turns OFF. This defines the mechanical origin.

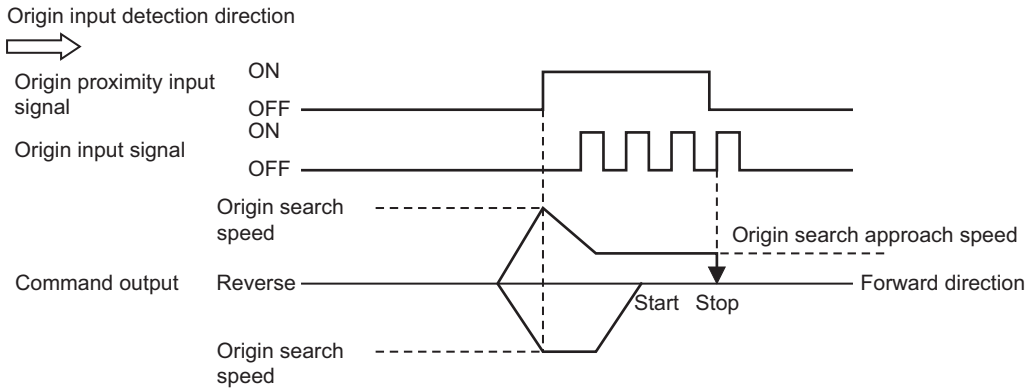

Reference

- ♦ If you start an origin search while the origin proximity input is ON, the operation will start at the origin search speed in the direction opposite to the origin input detection direction. After the origin proximity input turns OFF, the origin search operation will start at the origin search speed in the origin input detection direction.

Proximity Reverse Turn and Origin Proximity Input ON (Setting: 1)

1. When the origin proximity sensor turns ON, the axis starts decelerating to the origin search approach speed.
2. After the axis reaches the origin search approach speed, the axis stops at the first origin input signal. This defines the mechanical origin.

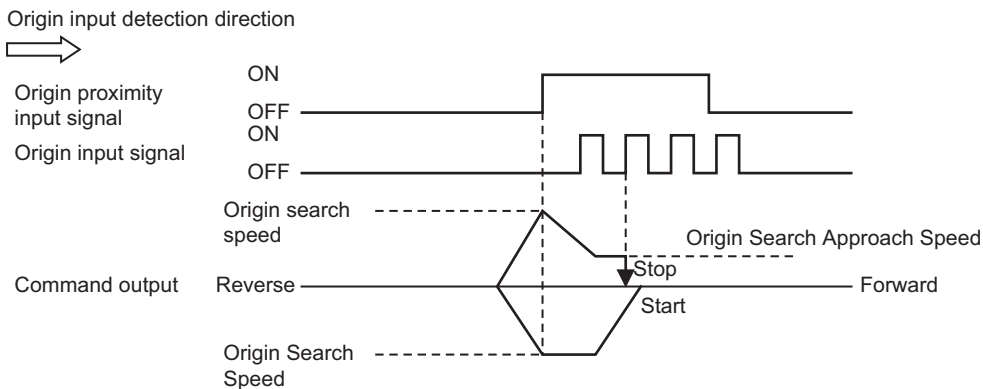

Reference

- ♦ If you start an origin search while the origin proximity input is ON, the operation will start at the origin search speed in the direction opposite to the origin input detection direction. After the origin proximity input turns OFF, the origin search operation will start at the origin search speed in the origin input detection direction.

Proximity Reverse Turn and Origin Proximity Input OFF (Approach Speed after Reverse Turn) (Setting: 2)

1. When the origin proximity sensor turns ON, the axis starts decelerating to the origin search approach speed.
2. After the axis reaches the origin search approach speed, the axis stops at the first origin input signal after the origin proximity sensor turns OFF. This defines the mechanical origin.

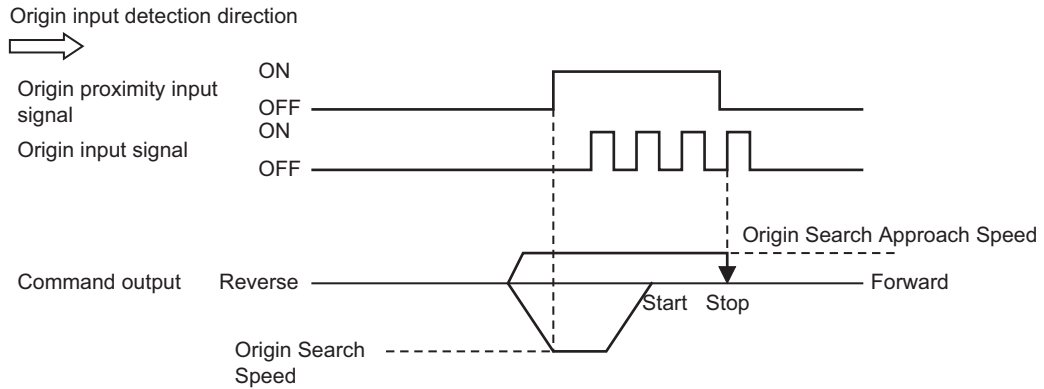

Reference

- ♦ If you start an origin search while the origin proximity input is ON, the operation will start at the origin search speed in the direction opposite to the origin input detection direction. After the origin proximity input turns OFF, the origin search operation will start at the origin search approach speed in the origin input detection direction.

Proximity Reverse Turn and Origin Proximity Input ON (Approach Speed After Reverse Turn) (Setting: 3)

1. When the origin proximity sensor turns ON, the axis starts decelerating to the origin search approach speed.
2. After the axis reaches the origin search approach speed, the axis stops at the first origin input signal. This defines the mechanical origin.

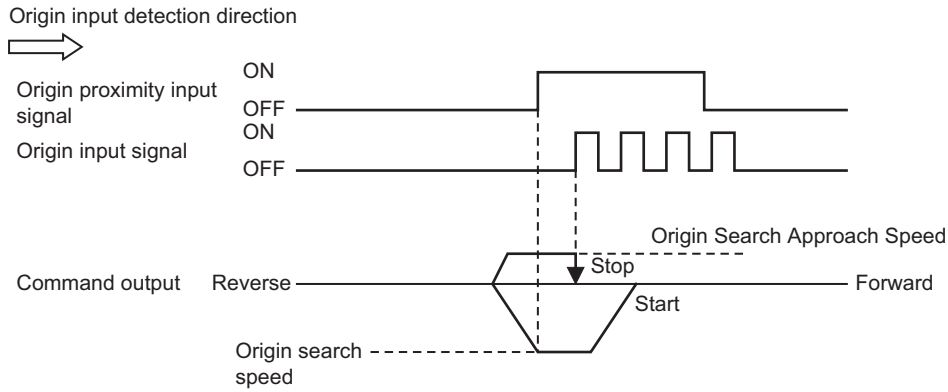

Reference

- ♦ If you start an origin search while the origin proximity input is ON, the operation will start at the origin search speed in the direction opposite to the origin input detection direction. After the origin proximity input turns OFF, the origin search operation will start at the origin search approach speed in the origin input detection direction.

Origin Proximity Input OFF (Setting: 4)

1. When the origin proximity sensor turns ON, the axis starts decelerating to the origin search approach speed.
2. After the axis reaches the origin search approach speed, the axis stops at the first origin input signal after the origin proximity sensor turns OFF. This defines the mechanical origin.

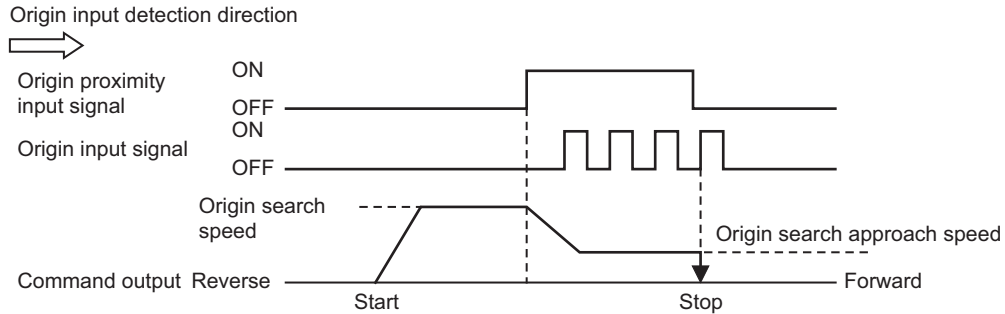

Reference

- If you start an origin search while the origin proximity sensor is ON, the axis performs the following operation depending on the setting of the origin search start direction.

Origin Search Start Direction Same as Origin Input Detection Direction

The axis does not perform a reverse turn operation and the origin search starts in the origin input detection direction at the origin search approach speed.

Origin Search Start Direction Different from Origin Input Detection Direction

Operation starts in the origin search start direction at the origin search speed, regardless of the status of the origin proximity input. If you set the operation at the limit input in the origin search start direction to Reverse, the axis reverses direction when limit input is detected and performs an origin search operation in the origin input detection direction.

Origin Proximity Input ON (Setting: 5)

1. When the origin proximity sensor turns ON, the axis starts decelerating to the origin search approach speed.
2. After the axis reaches the origin search approach speed, the axis stops at the first origin input signal. This defines the mechanical origin.

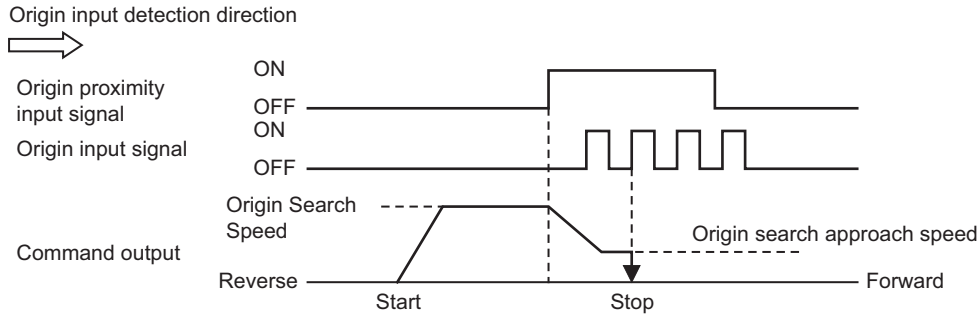

Reference

- ♦ If you start an origin search while the origin proximity sensor is ON, the axis performs the following operation depending on the setting of the origin search start direction.

Origin Search Start Direction Same as Origin Input Detection Direction

The axis does not perform a reverse turn operation and the origin search starts in the origin input detection direction at the origin search speed.

Origin Search Start Direction Different from Origin Input Detection Direction

Operation starts in the origin search start direction at the origin search speed, regardless of the status of the origin proximity input. If you set the operation at the limit input in the origin search start direction to Reverse, the axis reverses direction when limit input is detected and performs an origin search operation in the origin input detection direction.

No Origin Reverse Turn and Origin Proximity Input (Setting: 6)

1. An origin search starts at the origin search approach speed.
2. The axis stops at the first origin input signal. This defines the mechanical origin.

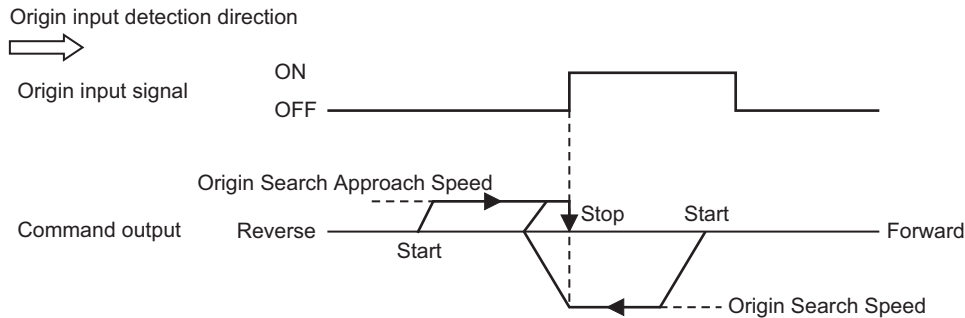

Reference

- If you start an origin search while the origin input is ON, the operation will start at the origin search speed in the direction opposite to the origin input detection direction. After the origin input turns OFF, the origin search operation will start at the origin search approach speed in the origin input detection direction.

No Origin Proximity Input (Setting: 7)

1. An origin search starts at the origin search approach speed.
2. The axis stops at the first origin input signal. This defines the mechanical origin.

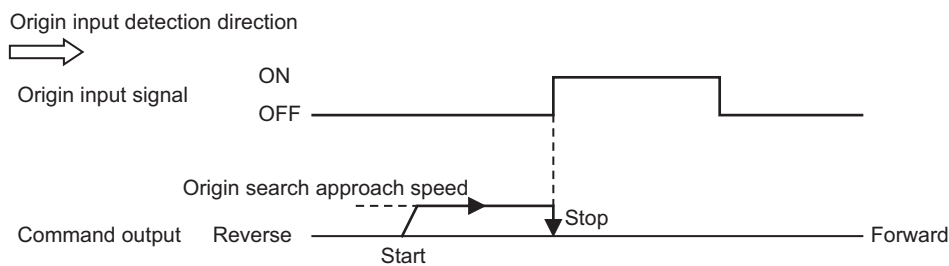

Reference

- If you start an origin search while the origin input is ON, the axis performs the following operation depending on the setting of the origin search start direction.

Origin Search Start Direction Same as Origin Input Detection Direction

The axis does not perform a reverse turn operation and the origin search starts in the origin input detection direction at the origin search approach speed.

Origin Search Start Direction Different from Origin Input Detection Direction

Operation starts in the origin search start direction at the origin search speed, regardless of the status of the origin proximity input. If you set the operation at the limit input in the origin search start direction to Reverse, the axis reverses direction when limit input is detected and performs an origin search operation in the origin input detection direction.

Limit Input OFF (Setting: 8)

1. The axis starts at the origin search speed. When the limit sensor in the direction opposite to the origin input detection direction turns ON, the axis starts decelerating to the origin search approach speed.
2. After the axis reaches the origin search approach speed, the axis stops at the first origin input signal after the limit sensor turns OFF. This defines the mechanical origin.

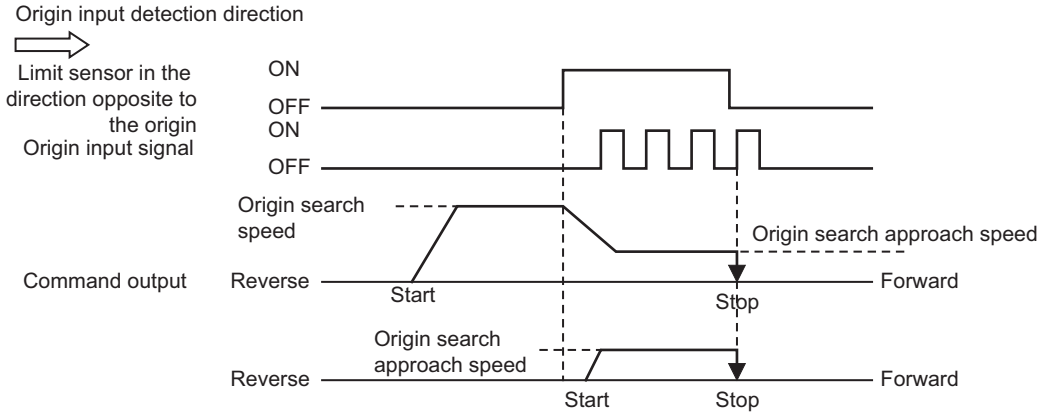

Reference

- ♦ If you perform an origin search while the limit input on the opposite side of the origin input detection direction is ON, the origin search operation starts at the origin search approach speed in the origin input detection direction.

Proximity Reverse Turn and Origin Input Mask Amount (Setting: 9)

1. When the origin proximity sensor turns ON, the axis starts decelerating to the origin search approach speed.
2. The axis moves by the specified amount of movement (i.e., the Origin Input Mask Amount) after the origin proximity sensor turns ON and stops at the first origin input signal. This defines the mechanical origin.

If the specified movement is too short and the movement would be completed before the axis decelerates to the origin search approach speed, an invalid origin input mask amount error (error code: 6407) occurs when you start the origin search.

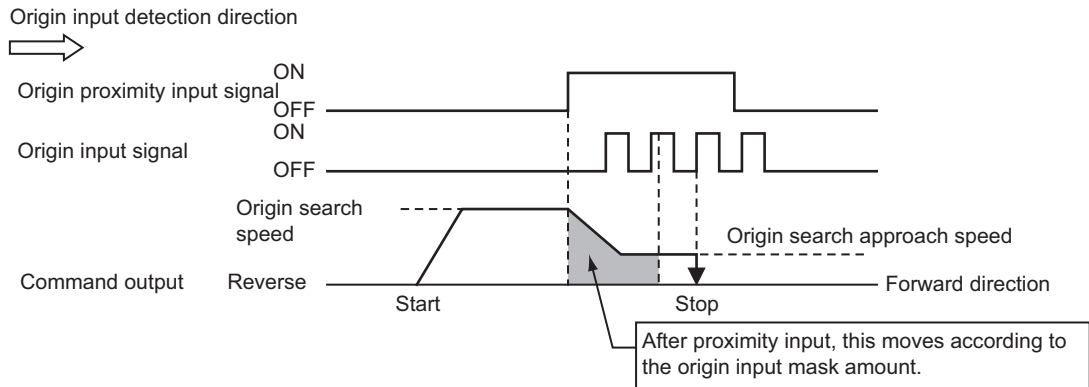

Reference

- ♦ If you start an origin search while the origin proximity input is ON, the operation will start at the origin search speed in the direction opposite to the origin input detection direction. After the origin proximity input turns OFF, the origin search operation will start at the origin search approach speed in the origin input detection direction.

Origin Proximity Input Only (Setting: 10)

1. The axis starts at the origin search speed. When the origin proximity sensor turns ON, the axis decelerates to a stop.
2. After the axis stops, the axis moves in the other direction at the origin search approach speed and stops when the origin proximity sensor turns OFF. This defines the mechanical origin.

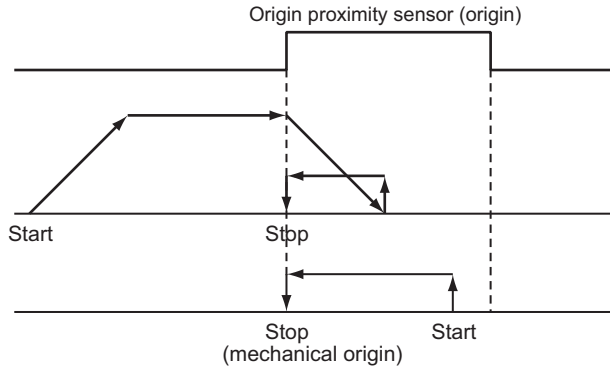

Reference

- ♦ If you use only the origin proximity input to perform an origin search, the point at which the origin proximity signal turns OFF during operation in the direction opposite to the origin input detection direction is set as the origin detection position.
- ♦ If you perform an origin search while the origin proximity input is ON, operation starts at the origin search approach speed in the direction opposite to the origin input detection direction, and the origin position detection ends when the origin proximity signal turns OFF.

Proximity Reverse Turn and Holding Time (Setting: 11)

1. When the origin proximity sensor turns ON, the axis starts decelerating to the origin search approach speed. The moment the axis starts decelerating, the torque limit output turns ON and time monitoring starts.
2. The mechanical origin is determined when the specified time elapses.

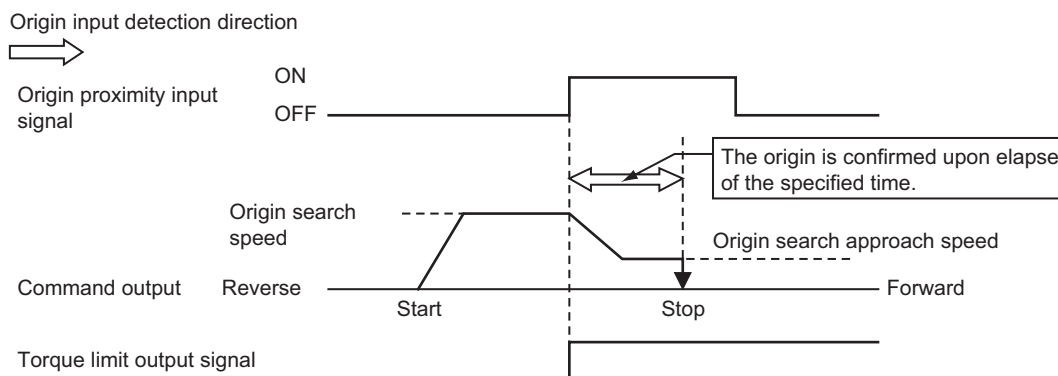

Precautions for Correct Use

Before using a mode in which the torque limit data is modified directly from the cyclic memory area, be sure to assign the torque limit data on the Direct Operation Command Memory Area.

Otherwise, the torque will not be correctly generated.

For details, refer to *Torque Limits* on page 10-19.



Reference

- If you start an origin search while the origin proximity input is ON, the operation will start at the origin search speed in the direction opposite to the origin input detection direction. After the origin proximity input turns OFF, the origin search operation will start at the origin search approach speed in the origin input detection direction.
- For information on the torque limit output, refer to *Automatic Control during Origin Searches* on page 10-19.
- To perform an origin search with this mode, you must set the torque limit in the Servo Drive.

Proximity Reverse Turn and Holding Origin Input (Setting: 12)

1. When the origin proximity sensor turns ON, the axis starts decelerating to the origin search approach speed. The moment the axis starts decelerating, the torque limit output turns ON.
2. The mechanical origin is determined when the origin input turns ON.

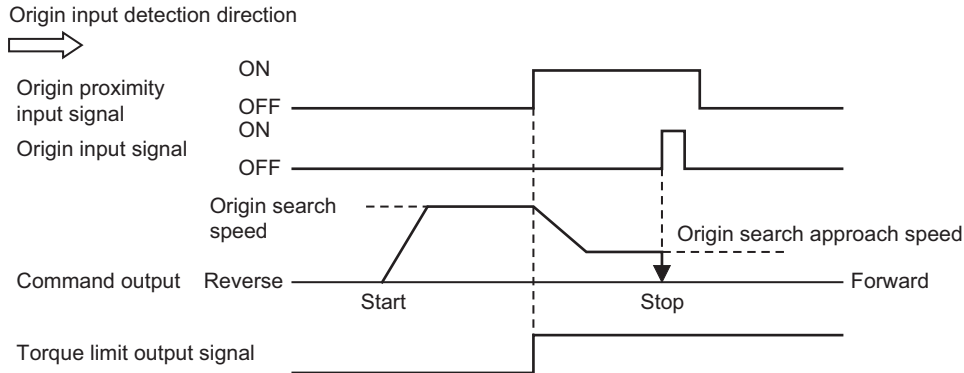

Precautions for Correct Use

Before using a mode in which the torque limit data is modified directly from the cyclic memory area, be sure to assign the torque limit data on the Direct Operation Command Memory Area.

Otherwise, the torque will not be correctly generated.

For details, refer to *Torque Limits* on page 10-19.



Reference

- ♦ If you start an origin search while the origin proximity input is ON, the operation will start at the origin search speed in the direction opposite to the origin input detection direction. After the origin proximity input turns OFF, the origin search operation will start at the origin search approach speed in the origin input detection direction.
- ♦ For information on the torque limit output, refer to *Automatic Control during Origin Searches* on page 10-19.
- ♦ To perform an origin search with this mode, you must set the torque limit in the Servo Drive.

No Origin Proximity Input and Holding Origin Input (Setting: 13)

1. The axis starts at the origin search approach speed and the torque limit output turns ON.
2. The mechanical origin is determined when the origin input turns ON.

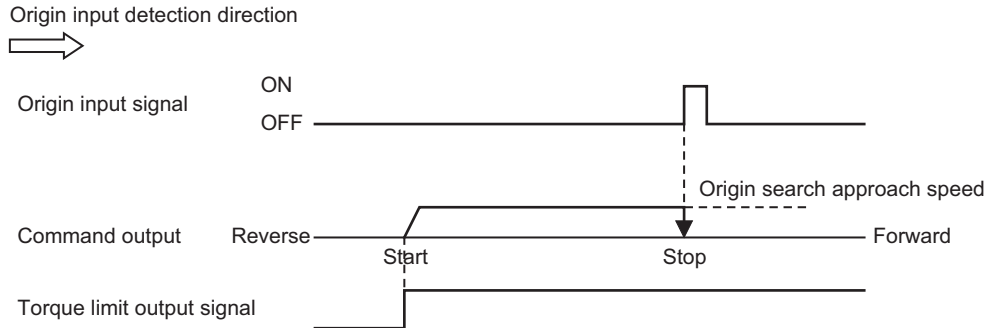

Precautions for Correct Use

Before using a mode in which the torque limit data is modified directly from the cyclic memory area, be sure to assign the torque limit data on the Direct Operation Command Memory Area.

Otherwise, the torque will not be correctly generated.

For details, refer to *Torque Limits* on page 10-19.



Reference

- ♦ For information on the torque limit output, refer to *Automatic Control during Origin Searches* on page 10-19.
- ♦ To perform an origin search with this mode, you must set the torque limit in the Servo Drive.

Origin Preset (Setting: 14)

1. The current position is set to the origin position offset to determine the mechanical origin.

When Origin Position Offset Is Set to 0

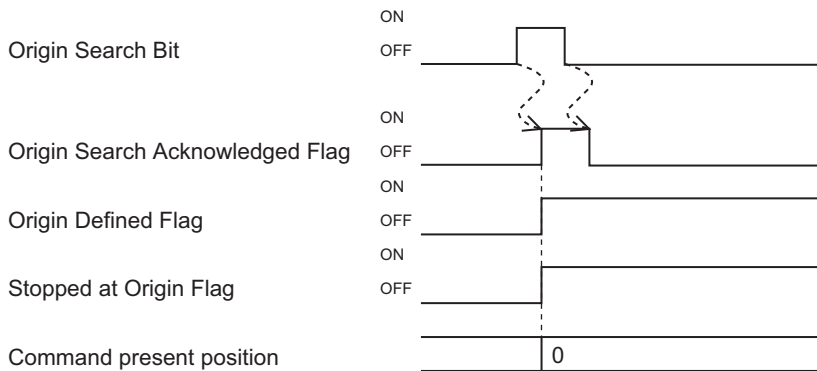

If you set the Origin Position Offset parameter to 0, the Stopped at Origin Flag also turns ON when the Origin Defined Flag turns ON.

Origin Position Latch

The Origin Position Latch function is available with the CJ1W-NC□81/NC□82 PCUs (unit version 1.3 or later).

The Origin Position Latch function stores in the PCU the position data when an origin input signal is received.

This function is supported in Origin Search Operation Modes (1 to 9, 12, 13) that use an origin input signal.

Origin Compensation

When you set an origin compensation value, the axis will move by the origin compensation value after the origin input is detected to define the origin.

Adjusting the origin for the workpiece can be difficult after the mechanical origin has been defined in a mechanical system. The origin compensation can be used to fine-tune the origin after the mechanical origin is determined.

This origin compensation is performed at the origin search compensation speed.

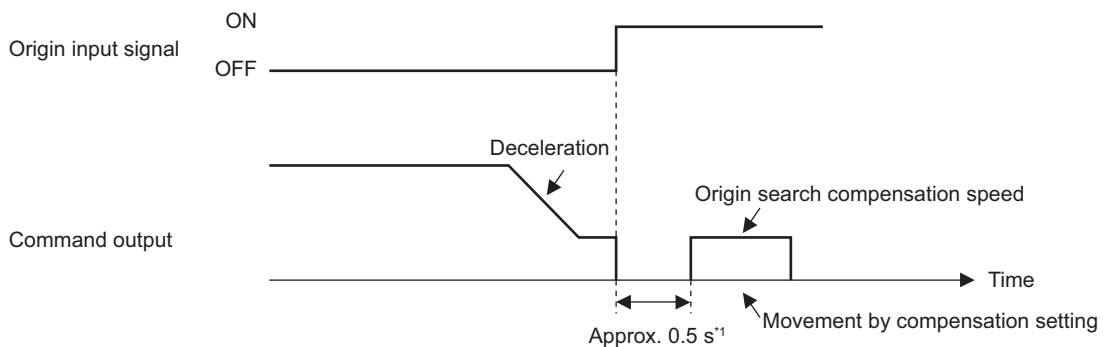

*1. If you use the Deviation Counter Reset Bit, origin compensation operation starts approx. 0.5 seconds after the Deviation Counter Reset Bit turns OFF.

Timing Charts

The following charts shows the timing of origin searches for axis 1.

Without Origin Compensation

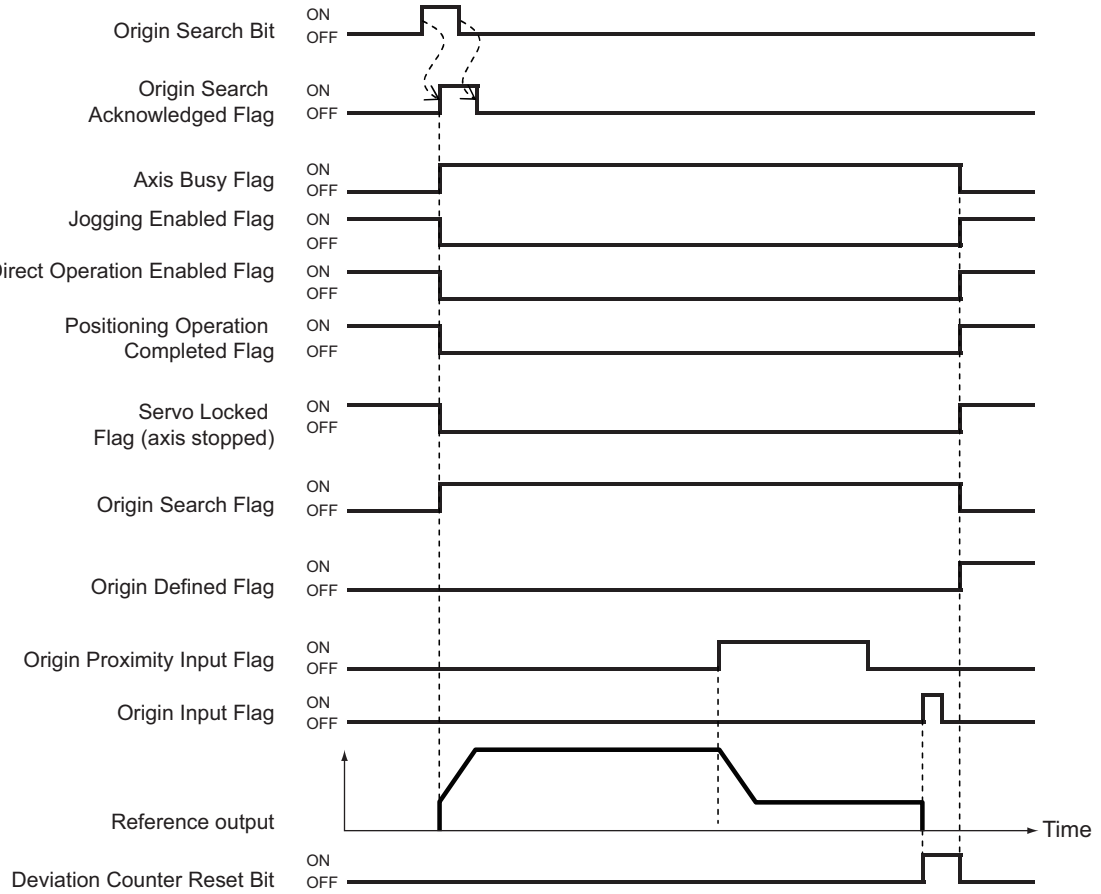

With Origin Compensation

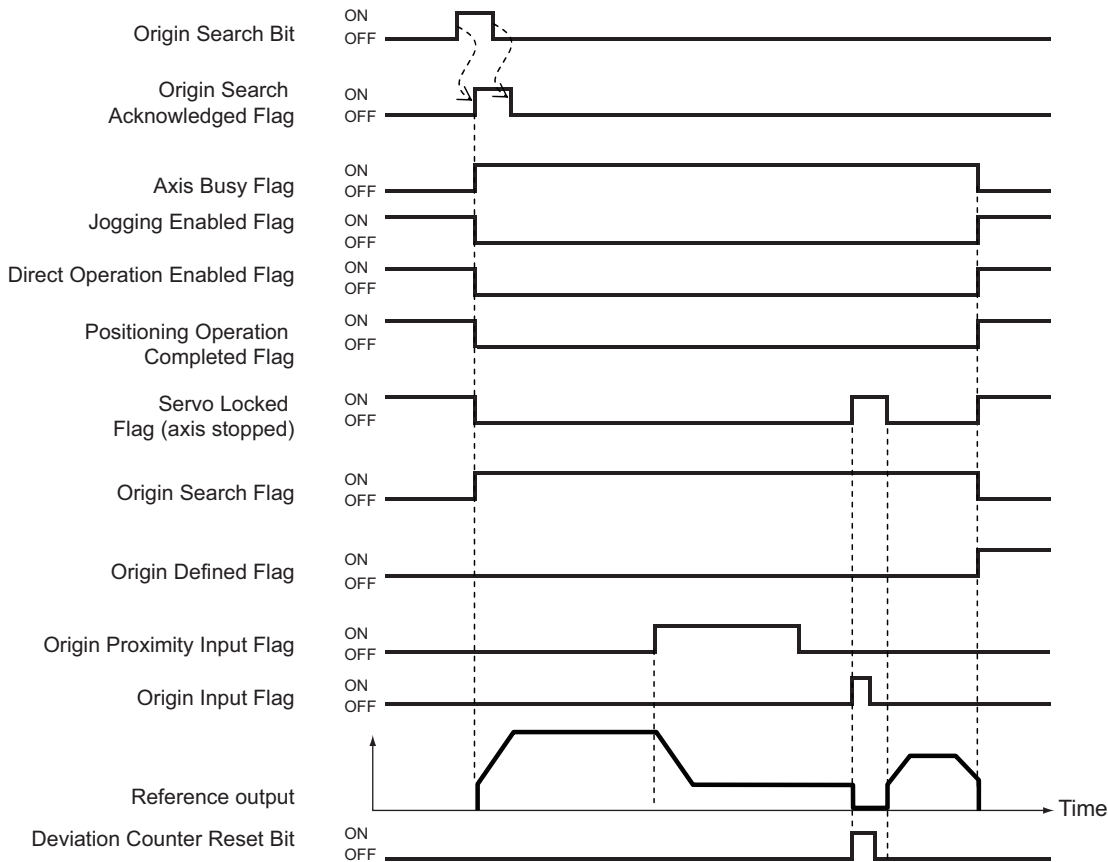

Deceleration Stop during an Origin Search

5

Defining the Origin

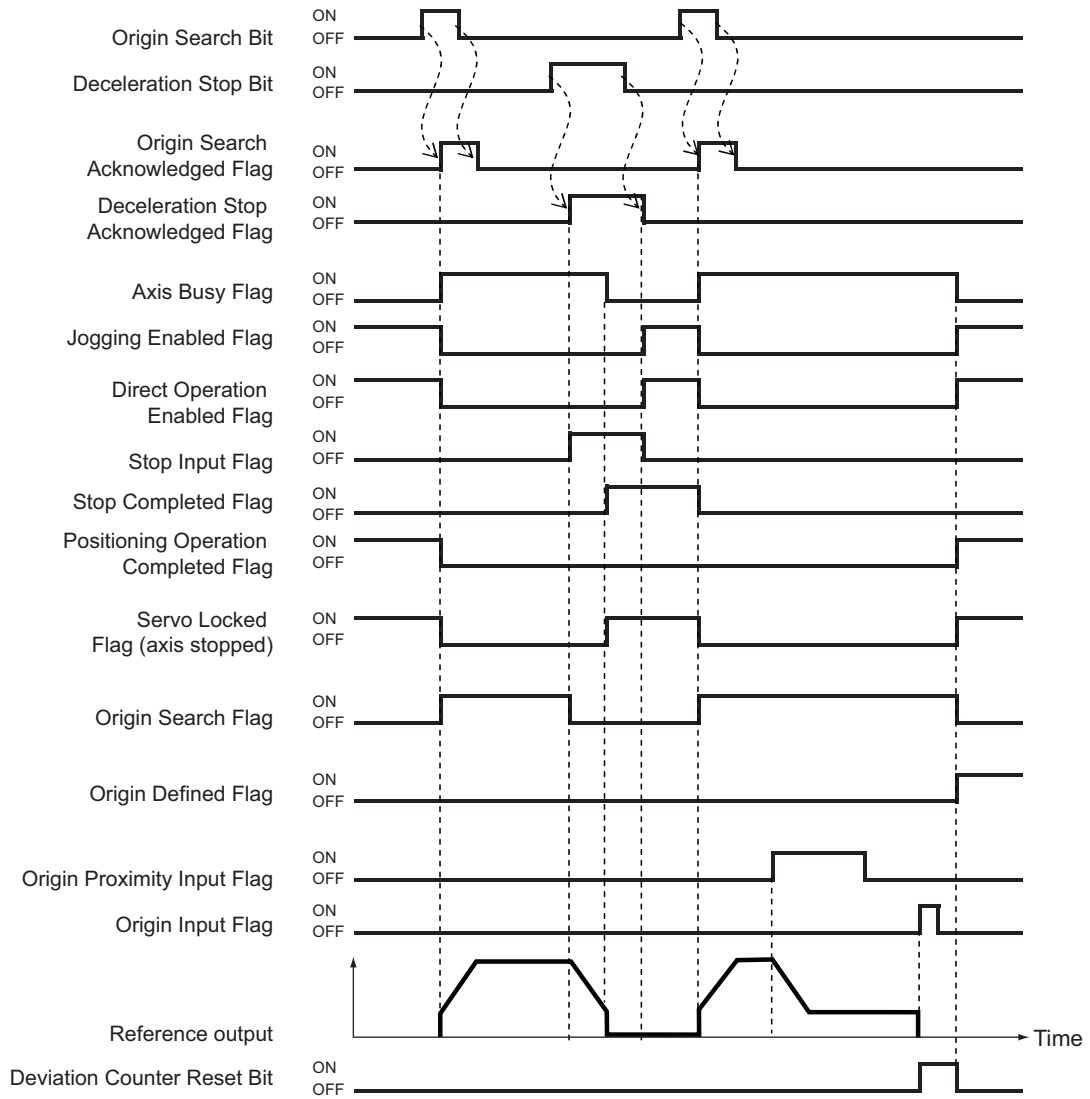

5-4 Present Position Preset

The present position preset function changes the present position to any specified value.

Outline of Operation

This PCU has three ways to preset the present position.

Origin Preset

An origin search can be used to change the present stop position of the mechanical origin to the origin position offset. The axis position is preset when the origin search is started.

For details, refer to *Origin Preset (Setting: 14)* on page 5-39.

Starting Present Position Clear Enable

This function presets the present position to 0 when positioning starts. It is useful for feeding control, such as feeder control.

However, if you use the starting present position clear enable function, the mechanical origin will be lost and the origin will become undefined.

Present Position Preset

This function changes the present position to any specified value.

When you execute a preset position preset, the mechanical origin is defined.

Starting Present Position Clear Enable

You can set this function for each axis with the Starting Present Position Clear Enable axis parameter. Positioning will be started after setting the present position to 0 for any axes for which this function is set.

The timing at which the present position is cleared is as follows:

Direct operation: FThe present position is cleared when the positioning function is started. This included multi-starts and when the interrupt input for interrupt feeding turns ON.

Memory operation: FThe present position is cleared when the Memory Operation Start Bit, Memory Operation Individual Start Bit, or interrupt input for interrupt feeding turns ON.



Precautions for Correct Use

- ◆ If you use the starting present position clear enable function, the mechanical origin will be lost and the origin will become undefined.



Reference

- When the Starting Present Position Clear Enable parameter is selected, the present position is preset to 0 not only when positioning starts, but also at multi-starts and when the interrupt input signal for interrupt feeding turns ON.
- Even if the axis is waiting for a condition to be met and is not operating when a start command bit turns ON, the present position will be preset to 0 when the sequence starts.
- For an origin return operation or for jogging/inching, the Starting Present Position Clear Enable parameter is disabled and the present position is not preset to 0.
- The present position is not preset to 0 when the axis stops and starts during memory operation (e.g., for positioning with an automatic pattern).

Present Position Preset

The present position will be changed to the value that is set in the Direct Operation Command Memory Area when the Present Position Preset Bit turns ON in the Direct Operation Command Memory Area. This will define the origin.

The present value can be set to any value without regards to the software limits. This enables operation beyond the software limits. For information on the bit allocations, refer to *Direct Operation Command Memory Area* on page 6-91.

Timing Chart

A timing chart for the present position preset is shown below.

When you change the present position to 0, it becomes the origin and thus the Stopped at Origin Flag turns ON.

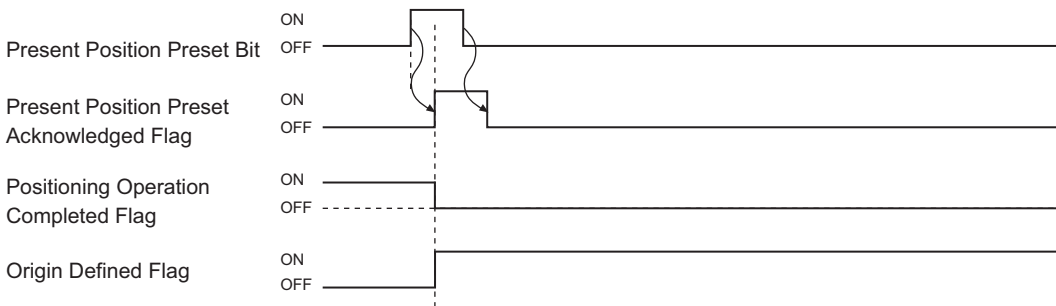

Precautions for Correct Use

An error will occur if the present position is preset outside of the ring range in Ring Mode or when the Axis Busy Flag is ON.

The present position will also not be preset while there is an error.

5-5 Origin Searches with CX-Programmer

Manual operation with the CX-Programmer makes it possible to perform the following five operations.

- ♦ Jogging
- ♦ Inching
- ♦ Direct operation
- ♦ Origin searches
- ♦ Wiring check

This section describes origin searches.



Precautions for Correct Use

- ♦ When you perform jogging, direct operation, or origin searches from the CX-Programmer, the motor actually operates at the specified speed.
Before you execute any operation, thoroughly confirm the absence of any hazard that may be caused by motor operation.
- ♦ When you operate the PCU from the CX-Programmer, install an external emergency stop circuit or take other appropriate measures to safely stop the motor. The CX-Programmer may not be able to send commands under some circumstances, e.g., if an error occurs in the computer.
- ♦ Click the Save Button to save the settings in the axis parameters.
To perform an origin search from a ladder program based on the parameters that you set in the Test Run Dialog Box, be sure to click the Save Button.

Origin Search Procedure

1. In the PCU Setting Window, select Test Run from the NC Unit Menu.

When the following caution dialog box appears, read the message carefully. After you confirm safety, click the OK Button.

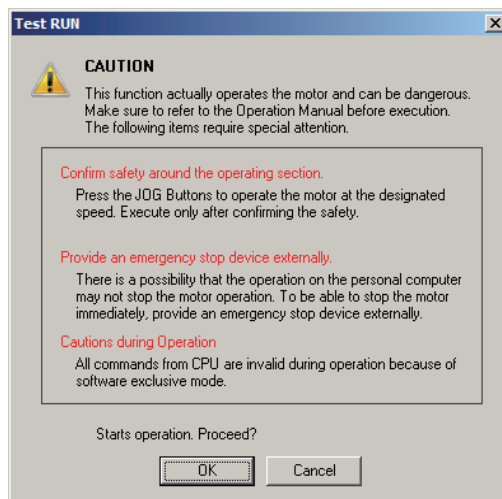



Precautions for Correct Use

- ◆ When you click the OK Button, the PCU will enter Support Software-controlled Operation Mode. Refer to *4-1 Outline of Manual Operation* on page 4-1 for information on Support Software-controlled Operation Mode.

2. When the Test Run Dialog Box appears, click the Origin Search Tab.

The following dialog box will appear.

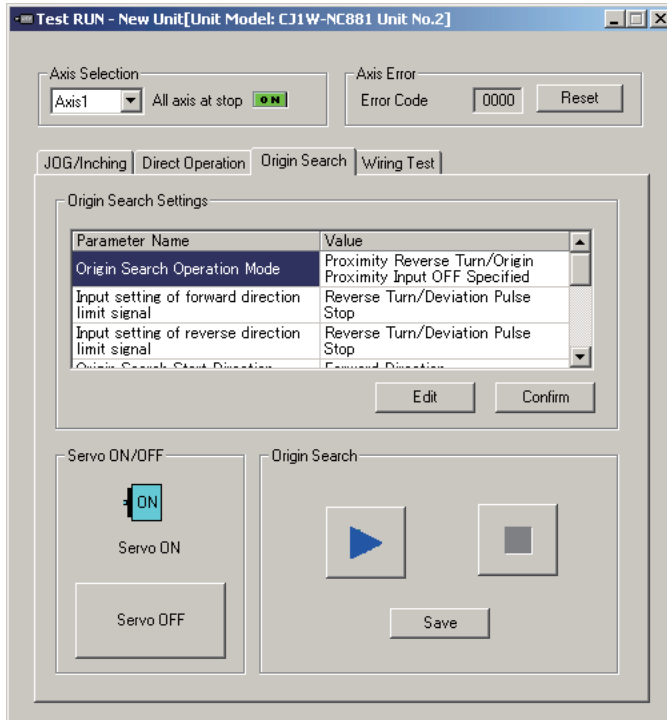

3. Select the axis whose originity you want to search for.

4. Confirm the origin search settings.

To change the settings, click the Edit Button. If the settings are OK, click the Confirm Button. When editing the Origin Search settings, the following dialog box will appear.

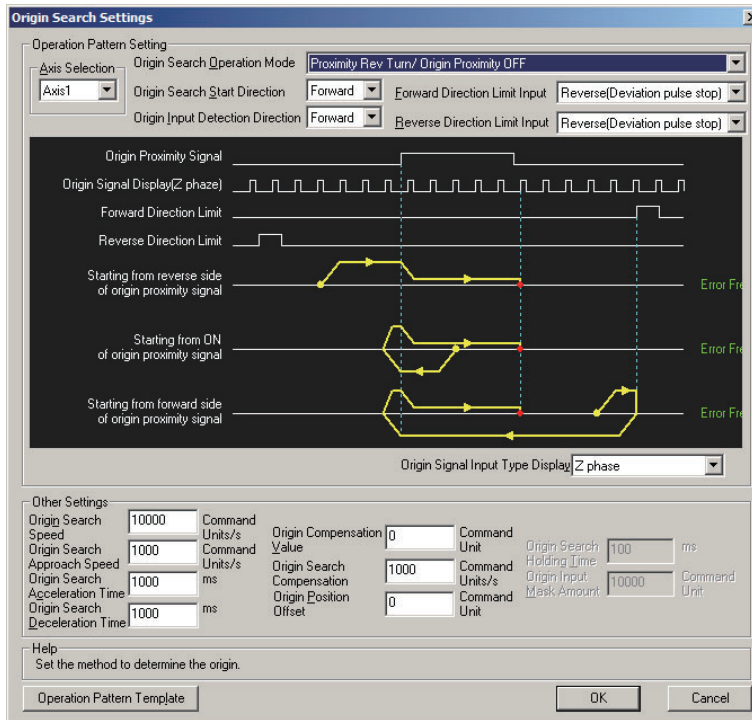

After you edit all necessary items, click the OK Button to close the dialog box.

If you edit the origin search settings, be sure to click the Confirm Button before you execute the origin search.

5. Press the Servo ON Button. The servo will be locked.**6. Execute the origin search operation.****Precautions for Correct Use**

In Support Software-controlled Operation Mode, operation commands can be given only for one axis.

Operation commands cannot be given simultaneously for more than one axis.

Even if the axis selection in the Test Run Dialog Box is changed, the new axis cannot be operated while operation is in progress for another axis.

5-6 Absolute Encoder Origin Setting

For an EtherCAT-compatible PCU, the position control loop is in the Servo Drive regardless of whether the application uses a semi-closed loop or full-closed loop.

However, the PCU can receive encoder feedback as communications data.

You can use either an incremental encoder or absolute encoder.

If you use an absolute encoder, the absolute data can be retained by the battery backup even when the power supply to the PLC (PCU) is turned OFF. You can determine the present position by reading this absolute data from the absolute encoder when the power supply to the PLC (PCU) turns ON.

Unlike when using an incremental encoder, once the origin has been defined, you do not need to perform another origin search after the power supply turns ON.

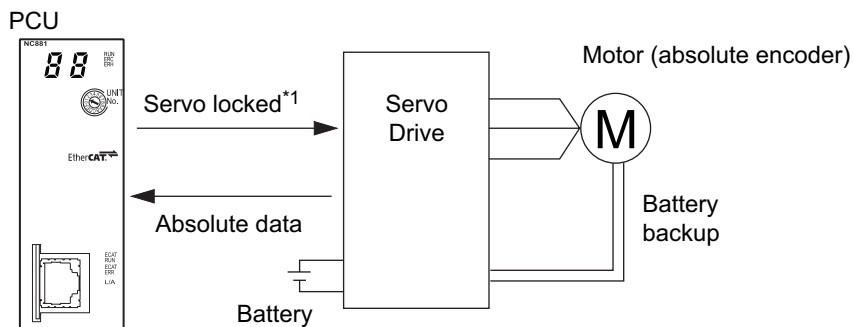

*1 With unit version 1.4 or later, you can select the origin establishment timing with a common parameter. For details, refer to the following function description.

Outline of Operation

To define the origin with an absolute encoder system, the absolute encoder offset compensation is performed when the servo lock command is executed.

Also, with unit version 1.4 or later, you can set the absolute encoder origin establishment timing to when communications is established so that the origin will be established at the following times in addition to when the servo is locked. If you set the absolute encoder origin establishment timing to when the servo is locked, the operation is the same as for previous unit versions.

Origin Establishment Timing

- ◆ When changing from initialization to normal operation
- ◆ When changing from Unit setup to normal operation
- ◆ When changing from Support Software control (data transfer) to normal operation
- ◆ When a slave changes from a communications error to normal communications

The origin can also be defined by performing an origin search in the same way as for an incremental encoder. When an origin search is performed with an absolute encoder system, the Absolute Encoder Origin Position Offset axis parameter will be set to the difference (i.e., the offset) between the present position after defining the origin and the absolute value read from the absolute encoder.

The Absolute Encoder Origin Position Offset axis parameter is a read-only parameter.



Precautions for Correct Use

- The setting of the Absolute Encoder Origin Position Offset parameter is saved when the power supply is turned OFF, so it must be saved in flash memory. Set the Absolute Encoder Rotation Axis Offset Automatic Save Setting common parameter to Automatically save. For details, refer to *Flash Memory Automatic Save Setting* on page 6-25.
- If the Absolute Encoder Rotation Axis Offset Automatic Save Setting parameter is set to *Do not automatically save*, the parameters must be saved. Refer to *9-7 Saving Data* on page 9-56 for the procedure to save data.

Applicable Servomotors

The Servomotors which are equipped with an absolute encoder and connectable to the PCU are listed below.

Manufacturer	Series	Servo Drive model	Servomotor model
OMRON	OMNUC G5 series	R88D-KN□-ECT (-R)	R88M-K□□□□□C R88M-K□□□□□T R88M-K□□□□□S

Connection with Servo Drive

Connect correctly according to *3-4 Wiring* on page 3-9.

Setting Procedure

This section describes the procedure to set the origin of an absolute encoder system.

1. Absolute Encoder Setup

The absolute encoder must be set up the first time it is used, when the motor is replaced, when the battery for the absolute encoder is exhausted, or any other time the absolute value data is lost.

After the absolute encoder is set up, the power supply to the Servo Drive must be cycled.

Refer to the *OMNUC G5-series AC Servomotors/Servo Drives with Built-in EtherCAT Communications User's Manual* (Cat. No. I573) for the setup method for OMNUC G5-series Servo Drives.

2. Setting of PCU Axis Parameters

Set the Encoder Type parameter in the Feedback Input Setting axis parameters.

For details, refer to *Feedback Input Settings* on page 6-57.

3. Executing the Origin Search

Execute the origin search.

Set the Origin Search Operation Mode in the Origin Search Setting axis parameters.

After the origin has been defined, the Absolute Encoder Origin Position Offset axis parameter will be set to the difference (i.e., the offset) between the present position after defining the origin and the absolute value read from the absolute encoder.



Precautions for Correct Use

Save the parameter after the origin has been set for the absolute encoder. Refer to 9-7 *Saving Data* on page 9-56 for the procedure to save data.



Reference

The following procedure is provided of an example of setting the origin in an absolute encoder system where first the machine origin position is defined and then the present position is set to 0.

- (1) **Set the Origin Search Operation Mode in the Origin Search Setting axis parameters to Origin Preset (Setting 14). Then set the Origin Position Offset to 0.**
- (2) **Move the machine to the origin position by using jogging or other operations.**
- (3) **Execute the origin search. After the origin search has been completed, the present position for the current machine position will be set to 0. At the same time, the Absolute Encoder Origin Position Offset will automatically be set according to the absolute data that is read from the absolute encoder.**
- (4) **The data is saved to save the Absolute Encoder Origin Position Offset into nonvolatile memory in the PCU.**

Timing Chart Example

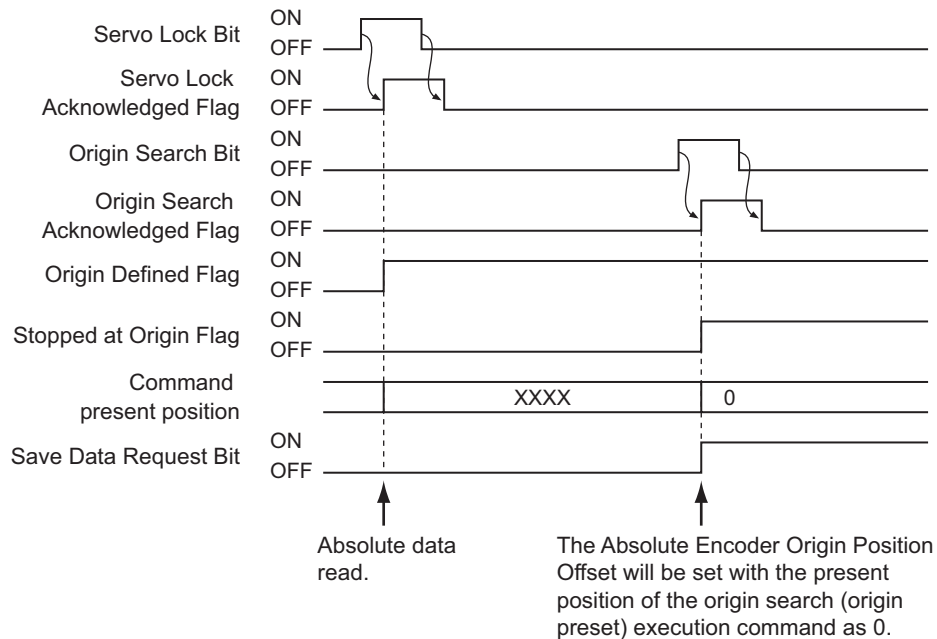

Absolute Encoder Setup

With an OMNUC G5-series Servo Drive, the absolute encoder must be set up the first time it is used, to initialize the rotation data to 0, when the absolute encoder has been stored for an extended period of time without a battery connected, etc.

The absolute encoder can be set up for the PCU using the following methods.

- ◆ Performing the absolute encoder setup procedure from the CX-Drive
- ◆ Using a function block from the OMRON FB Library in the user program to set up the absolute encoder



Precautions for Correct Use

After the absolute encoder is set up, the power supply to the Servo Drive must be cycled. When setup processing for the absolute encoder is completed, an absolute value clear error (A27.1) will occur in the Servo Drive. Cycle the control power supply to the Servo Drive to clear this error and complete the absolute encoder setup procedure.



Reference

- For the absolute encoder setup procedure from the CX-Drive, refer to the *CX-Drive Operation Manual* (Cat. No. W453).
- The following function block from the OMRON FB library can be used to set up the absolute encoder.

Initialize Absolute Encoder Function Block from the OMRON FB Library
 _NCx8x700_InitializeAbsEncoder

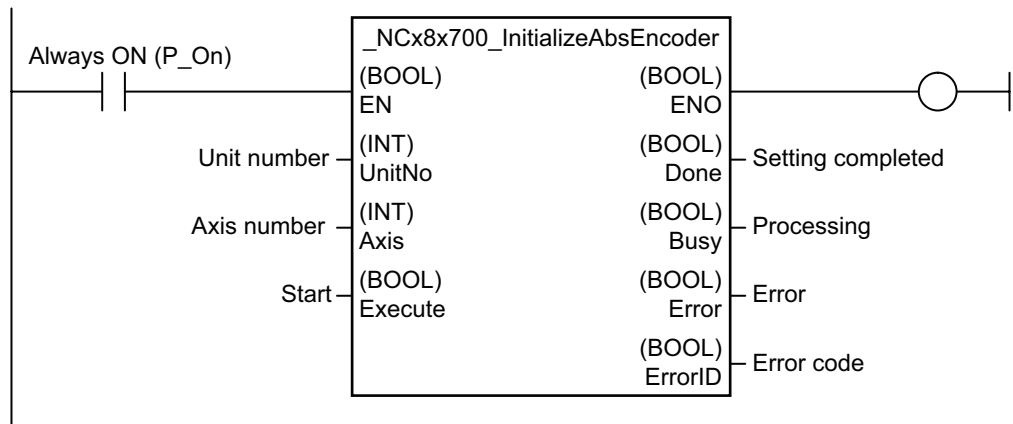

The absolute encoder can be set up by specifying the unit number and axis number in the function block and then turning ON the Start Bit.

Refer to the *OMRON FB Library Reference Manual* (Cat. No. W442) for details on the OMRON FB Library, including application conditions and precautions.

Using the Absolute Encoder for a Rotation Axis

If the Axis Feeding Mode parameter is set to 1 (rotation axis (infinite length)), the present position will function as a ring counter using the value set for the Rotation Axis Upper Limit parameter as the maximum value.

When using an absolute encoder for a rotation axis, the absolute encoder origin position offset will be automatically calculated and updated in the PCU each time the feedback present position completes one loop of the ring counter.

Completing one loop of the ring counter means that the feedback present position cycles through all of the 32 bits.

If the Absolute Encoder Rotation Axis Offset Automatic Save Setting common parameter is set to Automatically save, the absolute encoder origin position offset will automatically be saved to flash memory in the PCU whenever it is updated.

This enables recovering the current position of a rotation axis from the absolute encoder the next time power is turned ON even if the power to the PLC or Servo Drive is turned OFF.



Precautions for Correct Use

- ♦ If the Absolute Encoder Rotation Axis Offset Automatic Save Setting parameter is set to Do not automatically save, the parameters must be saved. Refer to 9-7 *Saving Data* on page 9-56.
- ♦ Saving to the built-in flash memory of the PCU occurs every time a rotation axis outputs 1,073,741,824 pulses when rotating in the forward or reverse direction.
The PCU is designed to write to distributed storage areas of the flash memory to prevent deterioration.
This ensures the flash memory to last its design life even if the PCU is used with OMNUC G5-series Servo Drives with 17-bit absolute encoders connected to 16 axes, running continuously at 3,000 rpm.
- ♦ If the Absolute Encoder Rotation Axis Offset Automatic Save Setting parameter is set to Automatically save, do not turn OFF the power supply or restart the PCU while the axis is operating. Doing so would result in failure to save data to the flash memory. If this is the case, a CPU Bus Unit memory error (error code: 0010) will occur.
The error means that the rotation axis cannot be correctly restored to the present position after power ON because the Absolute Encoder Origin Position Offset has not been updated.
If you do receive the error, be sure to perform an origin search again to update the Absolute Encoder Origin Position Offset.
- ♦ Do not run the rotation axis beyond 1,073,741,824 pulses (30 bits) while the power to the PCU is OFF. Should this limit be exceeded, the PCU cannot be correctly restored to the present position after power ON.

5-7 Origin Return Bit

You can perform an origin return to return the axis from any position to an absolute command position of 0. An origin return is performed when the Origin Return Bit is turned ON.

Refer to *Manual Operation Command Memory Area* on page 5-4 for information on the Origin Return Bit.



Precautions for Correct Use

- ◆ Execute an origin return only after defining the origin. If the origin is not defined, a present position unknown error (error code: 6006) will occur.
- ◆ An origin return operation cannot be started when any other operation is in progress.
- ◆ For a high-speed origin return, shortest route operation is always used for an infinite rotation axis.

Axis Parameter Settings

The origin return function can be used after the origin has been defined by an origin search or present position preset. To perform an origin return, you must set the same common parameters and axis parameters as you set for origin searches.

This section describes the axis parameters that are used exclusively for origin returns beyond the parameters set for Origin Search.

1. Click Axis Parameter in the project tree in the PCU Setting Window.

The window for setting the axis parameters will appear.

2. Select Origin Return Setting in the Parameter Type Box.

Set the Origin Return Speed, Origin Return Acceleration Time, and Origin Return Deceleration Time parameters.

Origin Return Settings

Parameter name	Function	Setting range	Unit	Default value
Origin Return Speed	Set the speed for an origin return.	1 to 2,147,483,647*1	Command units/s	10,000
Origin Return Acceleration Time	Set the acceleration time for an origin return.	0 to 250,000	ms	1,000
Origin Return Deceleration Time	Set the deceleration time for an origin return.	0 to 250,000	ms	1,000

*1. These setting ranges are for pulses.

Origin Return Speed

Set the speed for an origin return.

Origin Return Acceleration Time and Origin Return Deceleration Time

Set the acceleration time and deceleration time for an origin return.

The operation of the settings of the Origin Return Acceleration Time and Origin Return Deceleration Time parameters depends on the setting of the Acceleration Time Specification parameter.

For details, refer to *Acceleration/Deceleration Settings* on page 5-19 and *Acceleration/Deceleration Time Selection* on page 5-20.

Timing Chart

The following chart shows the timing of an origin return for axis 1.

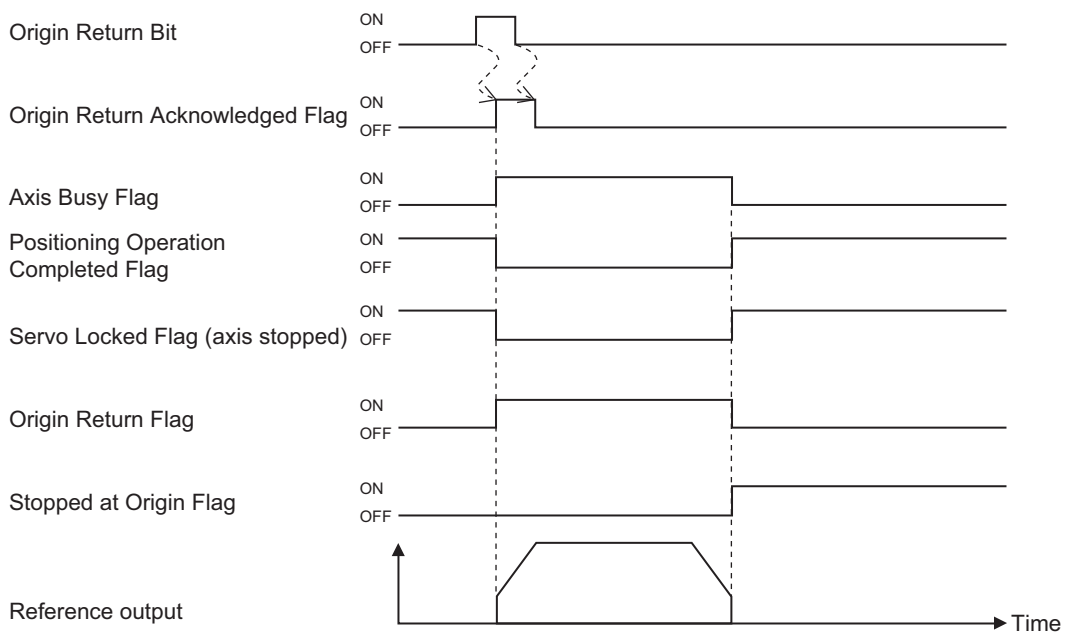

6

Setting Data

This section describes the overall data configuration, EtherCAT data settings, common parameters, axis parameters, and other data that is used for the PCU.

6-1	Overall Structure	6-1
6-2	EtherCAT Communications Settings	6-11
6-3	Common Parameters	6-15
6-4	Axis Parameters	6-29
6-5	Memory Operation Parameters	6-71
6-6	Operation Memory Areas	6-75
6-7	Memory Operation Data	6-147
6-8	Memory Operation Condition Data	6-163

6-1 Overall Structure

This section provides an outline of data exchange between the CPU Unit and PCU.

The CPU Unit and PCU exchange data as shown below.

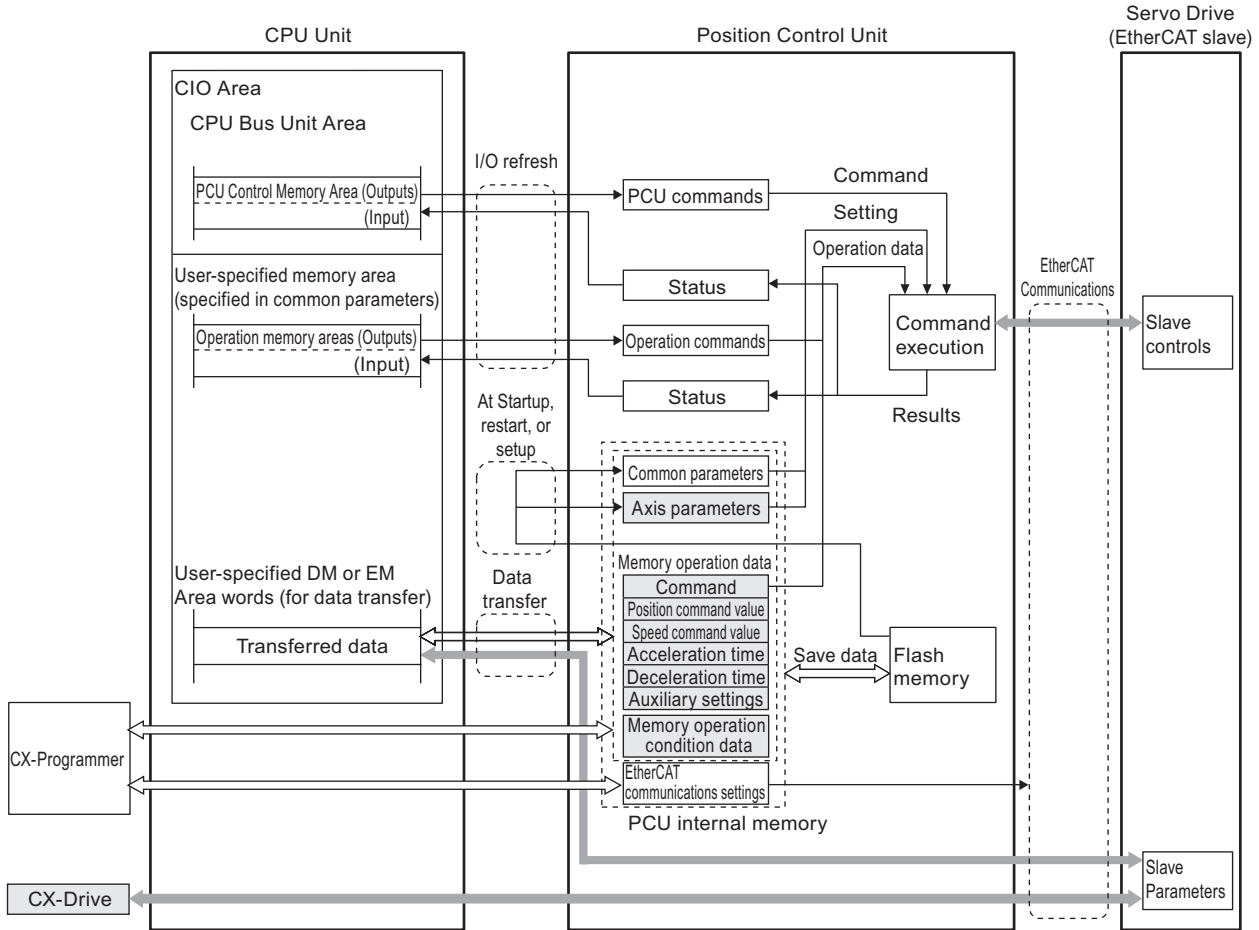

■ : The shaded areas are used when a G5-series Servo Drive is connected.

Parameters and Memory Areas List

The following tables list the 16 types of parameters, memory areas, and data that are used to operate the PCU.

Parameters

Data name	Description	Setting location
Common parameters	These parameters set the Direct Operation Command Memory Area and other memory areas that are basic in operating the PCU. You must set common parameters to use the PCU.	Internal flash memory in the PCU
Axis parameters	These parameters are used to set the command position units for axis operation, the maximum speed for each axis, etc.	
Memory operation parameters	These parameters set the configuration axes, interpolation operation settings, and other items that are related to memory operation.	
EtherCAT communications settings	These settings are for EtherCAT communications, such as the network configuration.	

Memory Areas

Data name	Description	Setting location
PCU Control Memory Areas	Bits and words for reading/writing data, resetting errors, error flags, error codes, and other items that are related to the PCU status are allocated in this area.	CPU Bus Unit Area in PLC
Manual Operation Command Memory Area	Bits and words for locking the servo, origin searches, jogging, inching, origin returns, and other items that are related to manual operation are allocated in this area.	The CIO Area, WR Area, HR Area, DM Area, and EM Area in the CPU Unit can be used.
Direct Operation Command Memory Area	Position data, speed data, acceleration/deceleration times, and other items that are related to direct operation, as well as command bits to start relative movement, absolute movement, and other operations are allocated in this area.	Use the common parameters to set these areas.
Axis Status Memory Area	Bits and words for busy flags for input status, locking the servo, positioning completed status, zones, axis error codes, present position monitoring, and other items that are related to axes are allocated in this area.	
Memory Operation Command Memory Area	Bits and words for sequence numbers for output status, resetting the M code, the teaching address, and other items that are related to memory operation are allocated in this area.	
Memory Operation Status Memory Area	Bits and words for memory operation errors for input status, memory operation error codes, M strobes, M codes, and other items that are related to memory operation are allocated in this area.	
Expanded Monitor Memory Area	This area can be used to monitor the feedback present position, position deviation, present speed, command torque, and other values.	

Data name	Description	Setting location
Remote I/O Output Memory Area	This area contains outputs bits that are allocated to remote I/O slaves with node addresses 17 to 80.	The CIO Area, WR Area, HR Area, and DM Area in the CPU Unit can be used. Use the common parameters to set these areas. Applicable to CJ1W-NC482/ 882/ F82 PCUs only.
Remote I/O Input Memory Area	This area contains input bits that are allocated to remote I/O slaves with node addresses 17 to 80.	
Remote I/O Communications Status Memory Area	This area contains communications status bits that are allocated to remote I/O slaves with node addresses 17 to 80.	

Memory Operation Data

Data name	Description	Setting location
Memory operation data	This data is used to set operation sequences, positions, speeds, acceleration/deceleration times, and other items that are related to memory operation.	Internal flash memory in the PCU
Memory operation conditions data	This data is used to set conditional expressions for condition data, comparison areas, timers, counters, and other items that are related to memory operation.	

Relation between Allocated Areas of Memory

Certain words in the I/O memory in the CPU Unit are allocated to the areas listed in the following table.

These areas contains I/O bits for Servo Drive control communications or the remote I/O master function, depending on the connected slave.

Communications for Servo Drive control can be used only when an OMNUC G5-series Servo Drive is connected.

Memory Area	I/O	Allocated words	Servo Drive control	I/O control
PCU Control Memory Area	I/O (between CPU Unit and PCU)	Words in the CPU Bus Unit Area	PCU control outputs (communications control outputs)	
			PCU control inputs (communications control inputs)	
Axis (Remote I/O) Operation Memory Areas	Output (CPU Unit to PCU)	First word: A, 2 words per axis (node)	Manual Operation Command Memory Area	Not used.
		First word: B, 12 words per axis (node)	Direct Operation Command Memory Area	Output Memory Area
	Input (PCU to CPU Unit)	First word: C, 13 words per axis (node)	Axis Status Memory Area	Input Memory Area
		F, 16 words per axis (node)	Expanded Monitor Memory Area	Input Memory Area

Memory Area	I/O	Allocated words	Servo Drive control	I/O control
Memory Operation Memory Areas	Output (CPU Unit to PCU)	D, 3 words per task	Memory Operation Command Memory Area	Not used.
	Input (PCU to CPU Unit)	E, 6 words per task	Memory Operation Status Memory Area	Not used.
Remote I/O Memory Areas	Output (CPU to PCU)	Variable length starting from word G (Default setting of word G: CIO 3800)	Not used.	Output Memory Area
	Input (PCU to CPU)	Variable length starting from word H (Default setting of word H: CIO3900)	Not used.	Input Memory Area
	Input (PCU to CPU)	20 words starting from word J (Default setting of word J: CIO3980)	Not used.	Communications Status Memory Area

Note: Words A to H and J are the first words in each area. These are set in the common parameters of the PCU.

For details, refer to 6-3 *Common Parameters* on page 6-15.

Allocations of Axis (Remote I/O) Operation Memory Areas

The Axis (Remote I/O) Operation Memory Areas are allocated according to the node addresses of the slaves.

With OMNUC G5-series Servo Drives, each node address corresponds to one axis.

Words are allocated to the node starting from the first word set in the common parameters. Words are allocated to node 1 first, and then in order to each node according to the node address. The same number of words is allocated to each node.



Precautions for Correct Use

For the Axis Operation Memory Areas, I/O words are still allocated for each node address even if not all node addresses are set.

Also, the control cycle will change. For information on the communications cycle, refer to 6-2 *EtherCAT Communications Settings* on page 6-11.

Allocations of Remote I/O Memory Areas

Remote I/O Memory Areas are used only by CJ1W-NC482/ 882/ F82 PCUs.

Remote I/O slaves can be connected for up to 640 words of input bits and 640 words of output bits. There are two methods to allocate the words in the Remote I/O Memory Areas: fixed allocations and free allocations.

Fixed Allocations

With fixed allocations, one word is automatically allocated per node address.

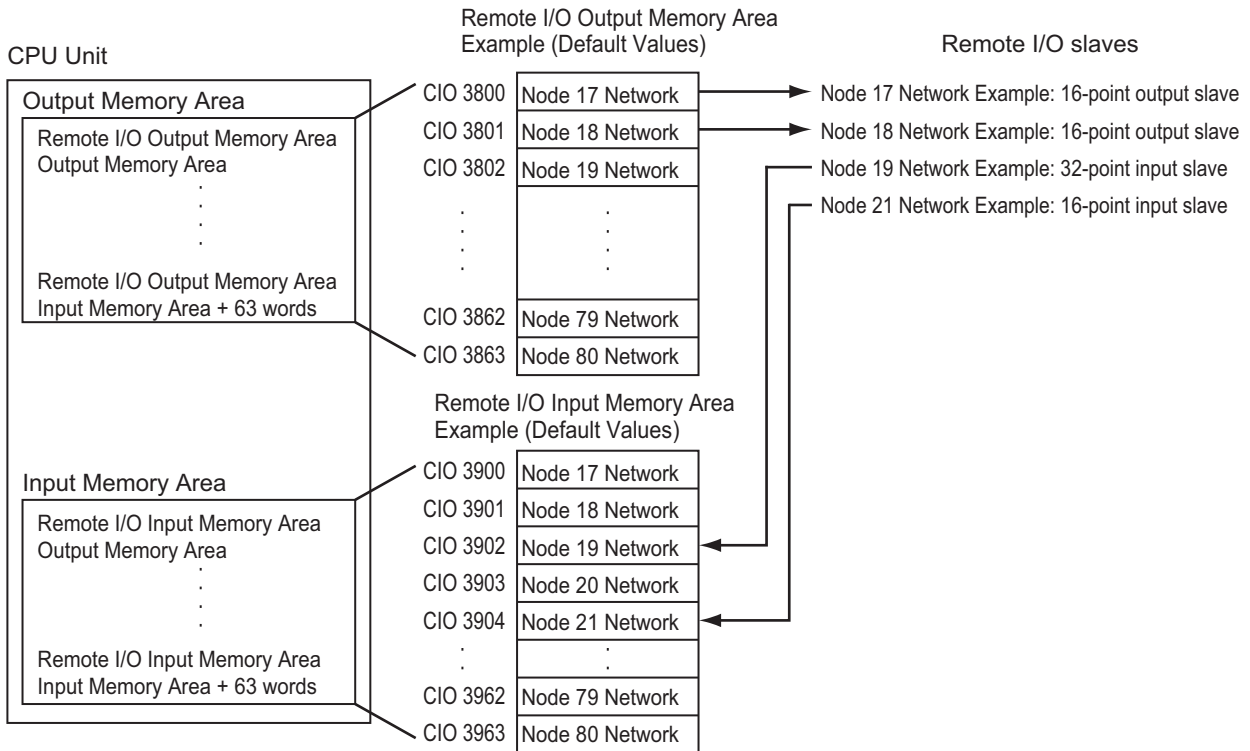

- ♦ If a slave has more than 16 inputs or outputs, more than one word will be allocated for that node address (slave).
- ♦ If there are less than 16 inputs or outputs to a slave, one word is used and the lower bits are allocated.

Precautions for Correct Use

If a remote I/O slave that uses two input words is registered, the next node address that can be registered is two higher than the node address used for the I/O slave with two input words. In this case, the total number of slaves that can be registered will be less than 64 nodes.

Example: When a 32-point (two-word) input slave is registered as node 17, the next node address that can be registered is 19. Node address 18 cannot be used for the input slave.



Reference

Fixed allocations can be conveniently used in the following cases to eliminate the need to set allocations manually.

- ◆ If the input areas and output areas contain less than 64 words
- ◆ If no more than 64 nodes total are registered for input and output bits

Free Allocations

Any words can be allocated to the remote I/O slaves as I/O memory areas.

This allocation method is used if the required number of nodes cannot be registered using fixed allocations.

At least one word is allocated per node address.

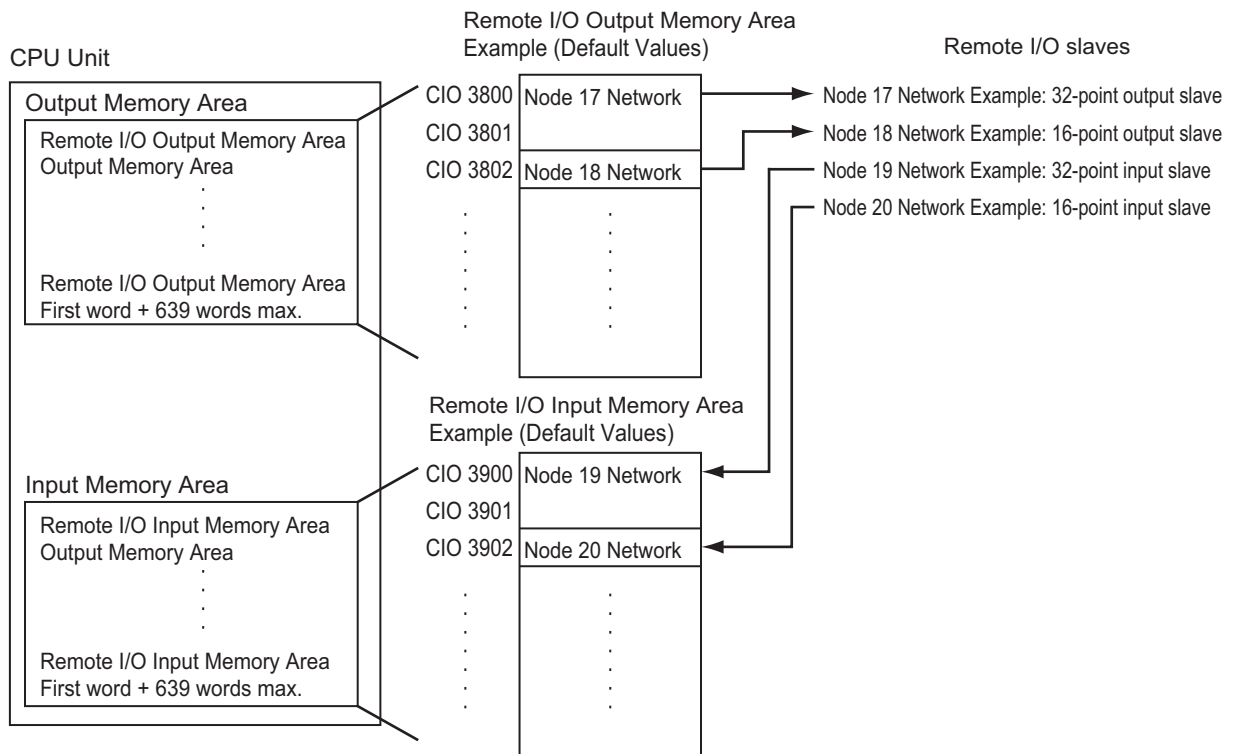

- ◆ If a slave has more than 16 inputs or output, more than one word will be allocated for that node address (slave).
- ◆ If there are less than 16 inputs or outputs to a slave, one word is used and the lower bits are allocated.

Checking and Setting Memory Area Allocations for Remote I/O Slaves

The CX-Programmer can be used to check the status of fixed allocations and set free allocations.

Checking the Status of Fixed Allocations

1. Click **Network Setting** in the project tree in the PCU Setting Window.
2. The editing window will be displayed on the right. Click the **Remote I/O Input/Output Memory Area Allocation List** Tab.

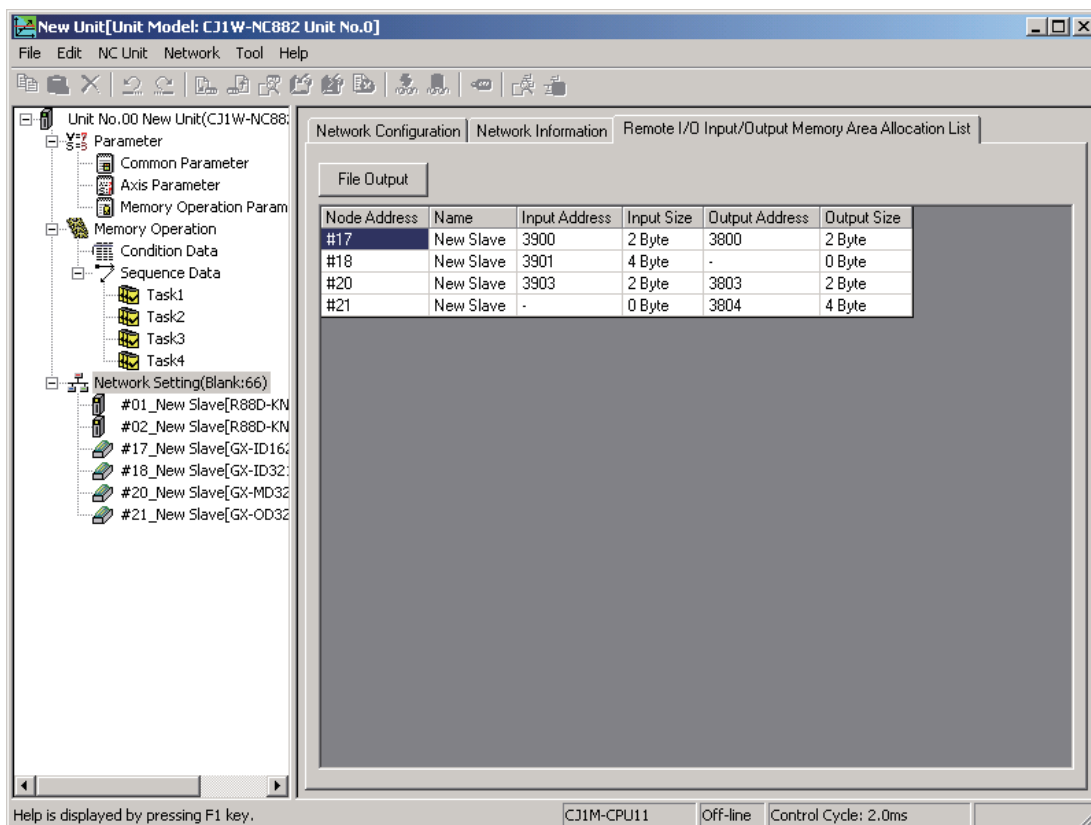

Name	Description
Node Address	Displays the name of the node address.
Name	Displays the name of the slave.
Input Address	Displays the first address of the input memory area allocated to the slave.
Input Size	Displays the input memory area size allocated to the slave.
Output Address	Displays the first address of the output memory area allocated to the slave.
Output Size	Displays the output memory area size allocated to the slave.

3. The node address, name, input address, input size, output address, and output size can be checked from a list.

Setting Free Allocations

1. Click **Network Setting** in the project tree in the **PCU Setting Window**.
2. The editing window will be displayed on the right. Click the **Remote I/O Input/Output Memory Area Allocation List Tab**.
3. The input address and output address can be edited to specify the memory area.

Application Example

The settings for a PCU with unit number 2 in the following configuration are shown below.

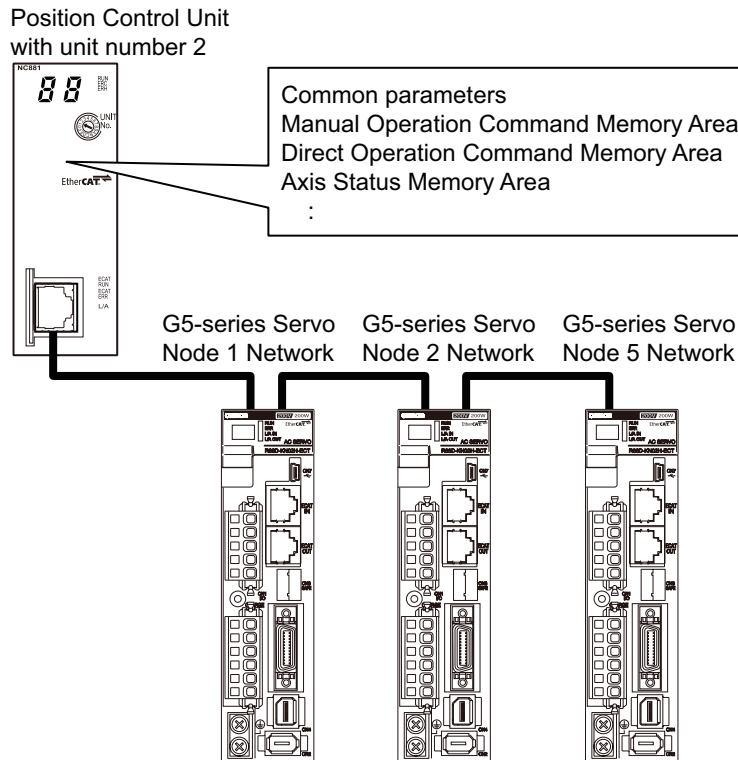

Memory Areas	Words	Allocated to	Description
PCU Control I/O Memory Area	1550 to 1574	Overall PCU operation	
Manual Operation Command Memory Area	100 to 101	Node address 1	Used for manual operation commands for axis 1 (G5-series Servo Drive).
	102 to 103	Node address 2	Used for manual operation commands for axis 2 (G5-series Servo Drive).
	104 to 105	Node address 3	Not used (because a station device is not connected, but the specified number of words are allocated anyway).
	106 to 107	Node address 4	
	108 to 109	Node address 5	Used for manual operation commands for axis 5 (G5-series Servo Drive).

Memory Areas	Words	Allocated to	Description
Direct Operation Command Memory Area	200 to 211	Node address 1	Used for direct operation commands for axis 1 (G5-series Servo Drive)
	212 to 223	Node address 2	Used for direct operation commands for axis 2 (G5-series Servo Drive)
	224 to 235	Node address 3	Not used (because a station device is not connected, but the specified number of words are allocated anyway).
	236 to 247	Node address 4	
	248 to 259	Node address 5	Used for direct operation commands for axis 5 (G5-series Servo Drive)
Axis Status Memory Area	300 to 312	Node address 1	Used for axis status for axis 1 (G5-series Servo Drive)
	313 to 325	Node address 2	Used for axis status for axis 2 (G5-series Servo Drive)
	326 to 338	Node address 3	Not used (because a station device is not connected, but the specified number of words are allocated anyway).
	339 to 351	Node address 4	
	352 to 364	Node address 5	Used for axis status for axis 5 (G5-series Servo Drive)

I/O memory area allocations for the remote I/O master function are based on the process data table of the connected slave.

Setting Data with the CX-Programmer

The CX-Programmer can be used to edit the following data.

- ♦ Common parameters
- ♦ Axis parameters
- ♦ Memory operation parameters
- ♦ Memory operation data
- ♦ Memory operation conditions data

This section describes procedures to edit data in the data setting window of the CX-Programmer.

Editing Procedure for Common Parameters, Axis Parameters, and Memory Operation Parameters

1. In the IO Table Window of the CX-Programmer, double-click the PCU Icon.
The PCU Setting Window will appear.
2. Select the parameters to be edited from the project tree in the PCU Setting Window.
3. Edit the parameter in the editing pane that appears on the right side.

Editing Procedure for Memory Operation Data

1. In the IO Table Window of the CX-Programmer, double-click the PCU Icon.
The PCU Setting Window will appear.
2. Select the sequence data to be edited from the project tree in the PCU Setting Window.
3. An editing pane will appear on the right side. Select the number of sequence data you want to edit.
4. Select the command.
5. When the required parameter appears on the right side of the command, select or enter the setting.
To disable the command, select the Invalid Check Box.

Editing Procedure for Memory Operation Condition Data

1. In the IO Table Window of the CX-Programmer, double-click the PCU Icon.
The PCU Setting Window will appear.
2. Select the conditions data to be edited in the memory operation data from the project tree in the PCU Setting Window.
3. An editing pane will appear on the right side. Click the row that shows the number of the condition data you want to edit.
4. Select the type.
5. Select or enter the desired condition in the displayed dialog box for editing detailed conditions.
6. Set the edge selection.

6-2 EtherCAT Communications Settings

This section gives the parameters related to PCU EtherCAT communications.

EtherCAT communications settings

The parameters related to EtherCAT communications are listed in the following table.

Name	Description	Setting range
Communications Cycle	Sets the communications cycle for the EtherCAT network.	250 μ s to 2,000 μ s
Repeat Count	Sets the number of retries for sending frames.	Always 0.
All Registered Slave Participation Standby Time	Sets the time to wait for all slaves (axes) to join the network.	10 to 200 s
Timeout Detection Count	Sets the number of times to detect timeouts.	1 to 8
Revision Checking Function Setting	Sets whether to verify the revisions of the connected slaves against the revisions in the network settings.	Enabled/Disabled
Operation at Error Detection	Sets whether to continue communications with connectable slaves or stop communications with all slaves when an error related to EtherCAT communications is detected.	Continue/Stop



Precautions for Correct Use

- ◆ If the revision check for the network settings is disabled, parameters will be transferred even if the revision of a slave is different from the revision in the network settings. If an incompatible revision of a slave is connected, incorrect parameters may be set and operation may not be correct. If you disable the revision check, make sure that only compatible slaves are connected before transferring the parameters.
- ◆ If the Operation at Error Detection parameter is set to stop operation, process data communications will stop for all slaves when an EtherCAT communications error is detected in a slave. For this reason, if Servo Drives are connected, the Servo Drives for all axes will be turned OFF. Make sure that the Operation at Error Detection parameter setting results in safe operation when a PCU error occurs.

Relation between the Number of Slaves and the Communications and Control Cycles

The setting ranges of the EtherCAT communications cycle and control cycle depend on the number of slaves that are connected.

Examples of the communications cycles and control cycles are given for when OMNUC G5-series Servo Drives are connected to the nodes with node addresses 1 to 16 and when remote I/O slaves are connected.

PCU models	Number of connected slaves		EtherCAT communications cycle	PCU control cycle
	G5-series Servo Drives	Remote I/O words used		
CJ1W-NC281 CJ1W-NC481 CJ1W-NC881 CJ1W-NCF81 CJ1W-NC482 CJ1W-NC882 CJ1W-NCF82	1 to 2	-	250 μs or 500 μs	0.5 ms
1 ms			1.0 ms	
2 ms			2.0 ms	
CJ1W-NC481 CJ1W-NC881 CJ1W-NCF81 CJ1W-NC482 CJ1W-NC882 CJ1W-NCF82	3 to 4	-	250 μs, 500 μs, or 1 ms	1.0 ms
2 ms			2.0 ms	
CJ1W-NC881*1 CJ1W-NCF81 CJ1W-NC882*1 CJ1W-NCF82	5 to 10	-	500 μs, 1 ms, or 2 ms	2.0 ms
CJ1W-NCF81 CJ1W-NCF82	11 to 16	-	1 ms or 2 ms	2.0 ms
CJ1W-NC482 CJ1W-NC882 CJ1W-NCF82	4	Inputs: 11 words, Outputs: 11 words (22 slaves connected)*2	250 μs, 500 μs, or 1 ms	1.0 ms
		2 ms	2.0 ms	
CJ1W-NC882 CJ1W-NCF82	8	Inputs: 32 words, Outputs: 32 words (64 slaves connected)*2	500 μs, 1 ms, or 2 ms	2.0 ms
		Inputs: 125 words, Outputs: 125 words (25 slaves connected)*3		
		Inputs: 205 words, Outputs: 205 words (41 slaves connected)*3	1 ms	3.0 ms
CJ1W-NCF82	16	Inputs: 32 words, Outputs: 32 words (64 slaves connected)*2	1 ms	3.0 ms
			2 ms	4.0 ms
		Inputs: 85 words, Outputs: 85 words (17 slaves connected)*3	1 ms	3.0 ms
			2 ms	4.0 ms

*1. A maximum of eight axes can be used.

*2. When 16-point Input Slaves and 16-point Output Slaves are connected.

*3. When SYSDRIVE MX2-series Inverters are connected. Each slave uses 5 input words and 5 output words.



Precautions for Correct Use

- ♦ The values given in the table are for when OMNUC G5-series Servo Drives are connected to the nodes with node addresses 1 to 16.
If remote I/O slaves are connected for node addresses 17 to 80 of the CJ1W-NC482/882/F82, the setting ranges of the EtherCAT communications cycle and the PCU control cycle will depend on the number of words that are used.
The values of the EtherCAT communications cycle and the PCU control cycle can be confirmed by clicking Network Settings in the CPU Parameter Setting Window of the CX-Programmer.
 - ♦ The setting range of the EtherCAT communications cycle time depends on the number of slaves that are connected and the total cable length. The values given in this manual and the default communications cycle setting in the PCU parameter setting windows of the CX-Programmer assume that the total cable length is 1,000 m or less.
If the total cable length is too long and the communications cycle is too short for the network configuration, a Master Communications Cycle Exceeded Warning (error code: 80A0) will occur. If this warning occurs, increase the communications cycle.
 - ♦ If node addresses of the connected slaves are skipped (i.e., not set in order), the PCU control cycle will be calculated for the number of slaves for which node addresses have been skipped. For example, if two slaves are connected to the CJ1W-NC881 with node addresses 1 and 8, the PCU control cycle will be the same as for when eight slaves are connected (i.e., 2.0 ms) even though only two slaves are actually connected.
-



Reference

- ♦ The EtherCAT communications cycle can be set within the above ranges. The PCU control cycle is determined by the setting of the EtherCAT communications cycle.
 - ♦ The remote I/O words used are given as reference for when the remote I/O master function of a CJ1W-NC482/NC882/F82 PCU is used.
-

Setting Parameters

This section shows how to set the parameters for EtherCAT communications when the CJ1W-NC281/481/881/F81/482/882/F82 is used as the master.

The CX-Programmer is used to set the parameters for EtherCAT communications.

Select Network Setting from the project tree in the PCU Setting Window to set the parameters.

Window Configuration

The following window is used to set the network settings.

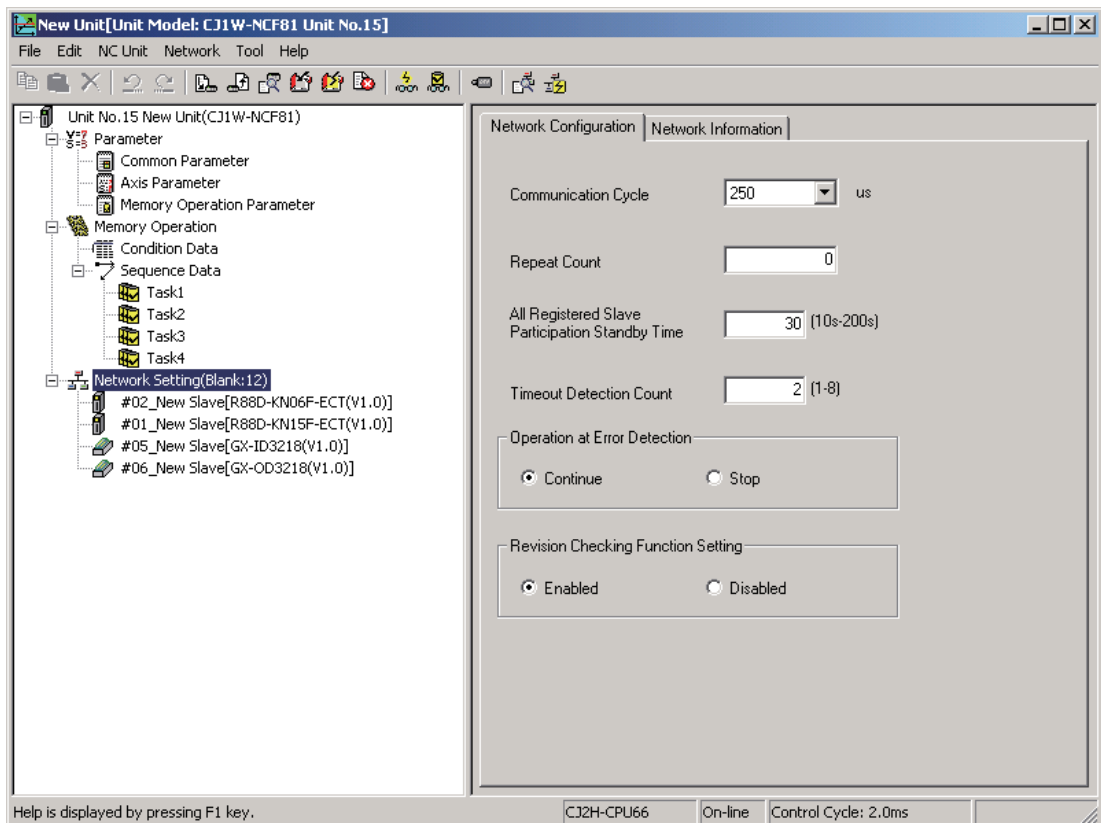

6-3 Common Parameters

Common parameters are used to specify the axis parameters and operation data setting areas that are necessary in axis operation. You must set the common parameters to use the PCU, but you need to set only the parameters that are necessary for the type of operation that is to be used.

The common parameter area is allocated in the internal flash memory of the PCU. Use CX-Programmer to set these parameters.

Common Parameter Table

The common parameters are listed in the following table.

General name	Parameter name	Reference page	Update timing
Operation Memory Area Allocation Settings	Manual Operation Command Memory Area Selection	6-17	At PCU startup, PCU restart, or PCU setup
	First Word of Manual Operation Command Memory Area		
	Direct Operation Command Memory Area Selection	6-18	
	First Word of Direct Operation Command Memory Area		
	Memory Operation Command Memory Area Selection	6-18	
	First Word in Memory Operation Command Memory Area		
	Axis Status Memory Area Selection	6-19	
	First Word in Axis Status Memory Area		
	Memory Operation Status Memory Area Selection	6-20	
	First Word in Memory Operation Status Memory Area		
	Expanded Monitor Memory Area Selection	6-21	
	First Word of Expanded Monitor Memory Area		
	Remote I/O Output Memory Area Selection ^{*1}	6-22	
	First Word of Remote I/O Output Memory Area ^{*1}		
	Remote I/O Input Memory Area Selection ^{*1}	6-23	
	First Word of Remote I/O Input Memory Area ^{*1}		
Remote I/O Communications Status Memory Area Selection ^{*1}	6-24		
First Word of Remote I/O Communications Status Memory Area ^{*1}			
Flash Memory Automatic Save Setting	Absolute Encoder Rotation Axis Offset Automatic Save Setting	6-25	
Input Data Resetting for Communications Error	Input Data Clear Mode for Communications Error	6-26	

General name	Parameter name	Reference page	Update timing
Synchronous Data Settings	Synchronous Data Link Send Selection 1	6-27	At PCU startup, PCU restart, or PCU setup
	Synchronous Data Link Send Selection 2		
	Synchronous Data Link Send Selection 3		
	Synchronous Data Link Send Selection 4		
	Synchronous Data Link Send Selection 5		
	Synchronous Data Link Send Selection 6		
	Synchronous Data Link Send Selection 7		
	Synchronous Data Link Send Selection 8		
	Synchronous Data Link Send Selection 9		
	Synchronous Data Link Send Selection 10		
	Synchronous Data Link Send Selection 11		
	Synchronous Data Link Send Selection 12		
	Synchronous Data Link Send Selection 13		
	Synchronous Data Link Send Selection 14		
	Synchronous Data Link Send Selection 15		
	Synchronous Data Link Send Selection 16		
	Synchronous Data Link Send Selection 17		
	Synchronous Data Link Send Selection 18		
	Synchronous Data Link Send Selection 19		
	Synchronous Data Link Send Selection 20		
	Synchronous Data Link Send Selection 21		
	Synchronous Data Link Send Selection 22		
	Synchronous Data Link Send Selection 23		
	Synchronous Data Link Send Selection 24		
	Synchronous Data Link Send Selection 25		
	Synchronous Data Link Send Selection 26		
	Synchronous Data Link Send Selection 27		
	Synchronous Data Link Send Selection 28		
	Synchronous Data Link Send Selection 29		
	Synchronous Data Link Send Selection 30		
	Synchronous Data Link Send Selection 31		
	Synchronous Data Link Send Selection 32		
Absolute Encoder Origin Establishment Timing Setting	Absolute Encoder Origin Establishment Timing Setting	6-28	

*1. Remote I/O Memory Areas are allocated only when using CJ1W-NC482/NC882/F82 PCUs.

Operation Memory Area Allocation Settings

These settings are used to allocate the operation I/O memory areas. To operate the axes, you need to allocate only the operation I/O memory areas that you will use.

The Operation Memory Area Allocation Settings are updated when the power supply is turned ON, the PCU is restarted, or the PCU is set up.

Manual Operation Command Memory Area Selection

You can select one of these 5 areas.

Area	Area name	Setting word range
No setting	–	–
CIO Area	Core I/O Area	0000 to 6143
WR Area	Work Area	W000 to W511
HR Area	Holding Area	H000 to H511
DM Area	Data Memory Area	D00000 to D32767
EM Area	Extended Data Memory Area	E00_00000 to E1C_32767 ^{*1}

*1. The number of banks that can be used depends on the model of the CPU Unit.

First Word of Manual Operation Command Memory Area

Specify the first word in the memory area that you specified for the Manual Operation Command Memory Area Selection parameter.



Precautions for Correct Use

- ♦ The Manual Operation Command Memory Area uses two words per axis. Set the first word so that the highest word allocated for used axes in the Direct Operation Command Memory Area does not exceed the setting word range of the area.
- ♦ Words are allocated for all axes up to the highest axis number used in the system. Words are also allocated for unused axis numbers between the words that are allocated for used axis numbers.



Reference

- ♦ For details on the Manual Operation Command Memory Area, refer to *Manual Operation Command Memory Area* on page 6-89.

Direct Operation Command Memory Area Selection

You can select one of these 5 areas.

Area	Area name	Setting word range
No setting	—	—
CIO Area	Core I/O Area	0000 to 6143
WR Area	Work Area	W000 to W511
HR Area	Holding Area	H000 to H511
DM Area	Data Memory Area	D00000 to D32767
EM Area	Extended Data Memory Area	E00_00000 to E1C_32767* ¹

*1. The number of banks that can be used depends on the model of the CPU Unit.

First Word of Direct Operation Command Memory Area

Specify the first word in the memory area that you specified for the Direct Operation Command Memory Area Selection parameter.



Precautions for Correct Use

- ♦ The Direct Operation Command Memory Area uses 12 words per axis. Set the first word so that the highest word allocated for used axes in the Direct Operation Command Memory Area does not exceed the setting word range of the area.
- ♦ Words are allocated for all axes up to the highest axis number used in the system. Words are also allocated for unused axis numbers between the words that are allocated for used axis numbers.



Reference

- ♦ For details on the Direct Operation Command Memory Area, refer to *Direct Operation Command Memory Area* on page 6-91.

Memory Operation Command Memory Area Selection

You can select one of these 5 areas.

Area	Area name	Setting word range
No setting	—	—
CIO Area	Core I/O Area	0000 to 6143
WR Area	Work Area	W000 to W511
HR Area	Holding Area	H000 to H511
DM Area	Data Memory Area	D00000 to D32767
EM Area	Extended Data Memory Area	E00_00000 to E1C_32767* ¹

*1. The number of banks that can be used depends on the model of the CPU Unit.

First Word in Memory Operation Command Memory Area

Specify the first word in the memory area you specified for the Memory Operation Command Memory Area Selection parameter.



Precautions for Correct Use

- ♦ The Memory Operation Command Memory Area uses 3 words per task. Set the first word so that the memory areas that correspond to the number of tasks that you use do not exceed the setting word range of each area.
- ♦ Words are allocated for all tasks up to the highest task number used in the system. Words are also allocated for unused task numbers between the words that are allocated for used task numbers.



Reference

- ♦ For details on the Memory Operation Command Memory Area, refer to *Memory Operation Command Memory Area* on page 6-114.

Axis Status Memory Area Selection

You can select one of these 5 areas.

Area	Area name	Setting word range
No setting	–	–
CIO Area	Core I/O Area	0000 to 6143
WR Area	Work Area	W000 to W511
HR Area	Holding Area	H000 to H511
DM Area	Data Memory Area	D00000 to D32767
EM Area	Extended Data Memory Area	E00_00000 to E1C_32767 ^{*1}

*1. The number of banks that can be used depends on the model of the CPU Unit.

First Word in Axis Status Memory Area

Specify the first word in the memory area that you specified for the Axis Status Memory Area Selection parameter.



Precautions for Correct Use

- ♦ The Axis Status Memory Area uses 13 words per axis. Set the first word so that the highest word allocated for used axes in the Direct Operation Command Memory Area does not exceed the setting word range of the area.
- ♦ Words are allocated for all axes up to the highest axis number used in the system. Words are also allocated for unused axis numbers between the words that are allocated for used axis numbers.



Reference

- ♦ For details on the Axis Status Memory Area, refer to *Axis Status Memory Area* on page 6-100.

Memory Operation Status Memory Area Selection

You can select one of these 5 areas.

Area	Area name	Setting word range
No setting	–	–
CIO Area	Core I/O Area	0000 to 6143
WR Area	Work Area	W000 to W511
HR Area	Holding Area	H000 to H511
DM Area	Data Memory Area	D00000 to D32767
EM Area	Extended Data Memory Area	E00_00000 to E1C_32767 ^{*1}

*1. The number of banks that can be used depends on the model of the CPU Unit.

First Word in Memory Operation Status Memory Area

Specify the first word in the memory area that you specified for the Memory Operation Status Memory Area Selection parameter.



Precautions for Correct Use

- ♦ The Memory Operation Status Memory Area uses 6 words per task. Set the first word so that the memory areas that correspond to the number of tasks that you use do not exceed the setting word range of each area.
- ♦ Words are allocated for all tasks up to the highest task number used in the system. Words are also allocated for unused task numbers between the words that are allocated for used task numbers.



Reference

- ♦ For details on the Memory Operation Status Memory Area, refer to *Memory Operation Status Memory Area* on page 6-115.

Expanded Monitor Memory Area Selection

You can select one of these 5 areas.

Area	Area name	Setting word range
No setting	–	–
CIO Area	Core I/O Area	0000 to 6143
WR Area	Work Area	W000 to W511
HR Area	Holding Area	H000 to H511
DM Area	Data Memory Area	D00000 to D32767
EM Area	Extended Data Memory Area	E00_00000 to E1C_32767 ^{*1}

*1. The number of banks that can be used depends on the model of the CPU Unit.

First Word of Expanded Monitor Memory Area

Specify the first word in the memory area that you specified for the Expanded Monitor Memory Area Selection parameter.



Precautions for Correct Use

- ♦ The Expanded Monitor Memory Area uses 16 words per axis. Set the first word so that the memory areas that correspond to the number of tasks that you use do not exceed the setting word range of each area.
- ♦ Words are allocated for all axes up to the highest task number used in the system. Words are also allocated for unused axis numbers between the words that are allocated for used axis numbers.



Reference

- ♦ For details on the Expanded Monitor Memory Area, refer to *Expanded Monitor Memory Area* on page 6-118.

Remote I/O Output Memory Area Selection

The Remote I/O Output Memory Area is allocated only when the CJ1W-NC482/882/F82 is used.

You can select one of these 5 areas.

Area	Area name	Setting word range
No setting	—	—
CIO Area	Core I/O Area	0000 to 6143
WR Area	Work Area	W000 to W511
HR Area	Holding Area	H000 to H511
DM Area	Data Memory Area	D00000 to D32767
EM Area	Extended Data Memory Area	E00_00000 to E1C_32767 ^{*1}

*1. The number of banks that can be used depends on the model of the CPU Unit.

First Word of Remote I/O Output Memory Area

Specify the first word in the memory area that you specified for the Remote I/O Output Memory Area Selection parameter.



Precautions for Correct Use

The number of words used by the Remote I/O Output Memory Area depends on the connected slaves and the allocation method. For details, refer to *Relation between Allocated Areas of Memory* on page 6-3.

Set the first word so that the highest word used in the I/O Slave Output Memory Area does not exceed the setting word range of the specified area.



Reference

- ♦ The default first word of the Remote I/O Output Memory Area is CIO 3800.
- ♦ For details on the Remote I/O Output Memory Area, refer to *Remote I/O Output Memory Area* on page 6-129.

Remote I/O Input Memory Area Selection

The Remote I/O Input Memory Area is allocated only when the CJ1W-NC482/882/F82 is used. You can select one of these 5 areas.

Area	Area name	Setting word range
No setting	–	–
CIO Area	Core I/O Area	0000 to 6143
WR Area	Work Area	W000 to W511
HR Area	Holding Area	H000 to H511
DM Area	Data Memory Area	D00000 to D32767
EM Area	Extended Data Memory Area	E00_00000 to E1C_32767 ^{*1}

*1. The number of banks that can be used depends on the model of the CPU Unit.

First Word of Remote I/O Input Memory Area

Specify the first word in the memory area that you specified for the Remote I/O Input Memory Area Selection parameter.



Precautions for Correct Use

The number of words used by the Remote I/O Input Memory Area depends on the connected slaves and the allocation method. For details, refer to *Relation between Allocated Areas of Memory* on page 6-3.

Set the first word so that the highest word used in the I/O Slave Output Memory Area does not exceed the setting word range of the specified area.



Reference

- The default first word of the Remote I/O Input Memory Area is CIO 3900.
- For details on the Remote I/O Input Memory Area, refer to *Remote I/O Input Memory Area* on page 6-130.

Remote I/O Communications Status Memory Area Selection

The Remote I/O Communications Status Memory Area is allocated only when the CJ1W-NC482/882/F82 is used.

You can select one of these 5 areas.

Area	Area name	Setting word range
No setting	—	—
CIO Area	Core I/O Area	0000 to 6143
WR Area	Work Area	W000 to W511
HR Area	Holding Area	H000 to H511
DM Area	Data Memory Area	D00000 to D32767
EM Area	Extended Data Memory Area	E00_00000 to E1C_32767*1

*1. The number of banks that can be used depends on the model of the CPU Unit.

First Word of Remote I/O Communications Status Memory Area

Specify the first word in the memory area that you specified for the Remote I/O Communications Status Memory Area Selection parameter.



Precautions for Correct Use

The Remote I/O Communications Status Memory Area uses 20 words. Set the first word so that the highest word used in the I/O Slave Output Memory Area does not exceed the setting word range of the specified area.



Reference

- ♦ The default first word of the Remote I/O Communications Status Memory Area is CIO 3980.
- ♦ For details on the Remote I/O Communications Status Memory Area, refer to *Remote I/O Communications Status Memory Area* on page 6-131.

Flash Memory Automatic Save Setting

This parameter sets automatically saving data in the flash memory.

Absolute Encoder Rotation Axis Offset Automatic Save Setting

This parameter sets whether to automatically save the origin position offset from the absolute encoder in the built-in flash memory when the Axis Feeding Mode parameter is set to 1 (rotation axis (infinite length)).

The setting for the Absolute Encoder Rotation Axis Offset Automatic Save Setting parameter is updated when the power supply is turned ON, when the PCU is restarted, or when the PCU Setup Bit is turned ON.

Parameter name	Function	Setting range	Unit	Default
Absolute Encoder Rotation Axis Offset Automatic Save Setting	Set whether to automatically save the data. 0: Do not automatically save. 1: Automatically save.	0, 1	–	1



Precautions for Correct Use

- ♦ If you are using an absolute encoder and the Axis Feeding Mode is set to 1 (rotary axis (infinite length)), always set the above parameter to 1 (automatically save). If automatic saving is not set, the position of the origin may be incorrect.
- ♦ The Data Transfer Flag will turn ON while data is being saved automatically and the Save Data Bit will result in a warning.

Input Data Resetting for Communications Error

Sets the input data resetting method for when a communications error occurs.

Input Data Clear Mode for Communications Error

All input data for a slave can be reset to zero when a communications error occurs in a slave. If resetting is disabled, input data in the slave is held when a communications error occurs in the slave.

This setting is enabled for remote I/O slaves only. If an OMNUC G5-series Servomotor is connected, this setting is disabled.

Parameter name	Function	Setting range	Unit	Default
Input Data Clear Mode for Communications Error	Sets whether to enable the function. 0: Disabled 1: Enabled	0, 1	–	0



Precautions for Correct Use

The Input Data Clear Mode for Communications Error setting does not apply to the Synchronous Data Link function. Input data will be retained if a communications error occurs.

Synchronous Data Settings

These parameters are available when using the Synchronous Data Link function.

Parameter name	Function	Setting range	Unit	Default	
Synchronous Data Link Send Selection 1	For each parameter, select the axis number and the data type.	0100 hex to 50FF hex	–	0	
Synchronous Data Link Send Selection 2		0100 hex to 50FF hex	–	0	
Synchronous Data Link Send Selection 3		0100 hex to 50FF hex	–	0	
Synchronous Data Link Send Selection 4	Axis number 00 (00 hex): Not selected.	0100 hex to 50FF hex	–	0	
Synchronous Data Link Send Selection 5		01 to 16 (01 to 10 hex): Displays the axis number of the Servo Drive axis.	0100 hex to 50FF hex	–	0
Synchronous Data Link Send Selection 6		17 to 80 (11 to 50 hex): Displays the remote I/O node number.	0100 hex to 50FF hex	–	0
Synchronous Data Link Send Selection 7	Data type	0100 hex to 50FF hex	–	0	
Synchronous Data Link Send Selection 8	Servo Drive axis 00: Feedback present position	0100 hex to 50FF hex	–	0	
Synchronous Data Link Send Selection 9		01: Command present position 02: Position deviation	0100 hex to 50FF hex	–	0
Synchronous Data Link Send Selection 10		03: Feedback present speed 04: Command present speed	0100 hex to 50FF hex	–	0
Synchronous Data Link Send Selection 11	05: Present torque 06: Command torque	0100 hex to 50FF hex	–	0	
Synchronous Data Link Send Selection 12		0B: Feedback present speed 2 ^{*1} 0C: Command present speed 2 ^{*2}	0100 hex to 50FF hex	–	0
Synchronous Data Link Send Selection 13		Remote I/O	0100 Hex to 50FF Hex	–	0
Synchronous Data Link Send Selection 14	Select the index of a TxPDO object.	0100 hex to 50FF hex	–	0	
Synchronous Data Link Send Selection 15		0100 hex to 50FF hex	–	0	
Synchronous Data Link Send Selection 16		0100 hex to 50FF hex	–	0	
Synchronous Data Link Send Selection 17		0100 hex to 50FF hex	–	0	
Synchronous Data Link Send Selection 18		0100 hex to 50FF hex	–	0	
Synchronous Data Link Send Selection 19		0100 hex to 50FF hex	–	0	
Synchronous Data Link Send Selection 20		0100 hex to 50FF hex	–	0	
Synchronous Data Link Send Selection 21		0100 hex to 50FF hex	–	0	
Synchronous Data Link Send Selection 22		0100 hex to 50FF hex	–	0	

Parameter name	Function	Setting range	Unit	Default
Synchronous Data Link Send Selection 23	Refer to the previous page.	0100 hex to 50FF hex	—	0
Synchronous Data Link Send Selection 24		0100 hex to 50FF hex	—	0
Synchronous Data Link Send Selection 25		0100 hex to 50FF hex	—	0
Synchronous Data Link Send Selection 26		0100 hex to 50FF hex	—	0
Synchronous Data Link Send Selection 27		0100 hex to 50FF hex	—	0
Synchronous Data Link Send Selection 28		0100 hex to 50FF hex	—	0
Synchronous Data Link Send Selection 29		0100 hex to 50FF hex	—	0
Synchronous Data Link Send Selection 30		0100 hex to 50FF hex	—	0
Synchronous Data Link Send Selection 31		0100 hex to 50FF hex	—	0
Synchronous Data Link Send Selection 32		0100 hex to 50FF hex	—	0

*1. Monitors the OMNUC G5-series Servo Drive's 606C hex velocity actual value (process data object). If the 606C hex velocity actual value object is not mapped, this is 0.

*2. Monitors the same value as 04 (command present speed) during linear or circular interpolation in memory operation or during the execution of the Synchronous Feeding Position function. This is 0 when unit performs synchronous feeding torque control.

Absolute Encoder Origin Establishment Timing Setting

You can set the timing for establishing the absolute encoder origin.

Absolute Encoder Origin Establishment Timing Setting

If you set this parameter to when communications are established with unit version 1.4 or later, the origin will be established at the following times in addition to when the servo is locked. If you set the parameter to when the servo is locked, the origin will be established only when the servo is locked, just as for previous unit versions.

Origin Establishment Timing

- ◆ When changing from initialization to normal operation
- ◆ When changing from Unit setup to normal operation
- ◆ When changing from Support Software control (data transfer) to normal operation
- ◆ When a slave changes from a communications error to normal communications

Parameter name	Function	Setting range	Unit	Default
Absolute Encoder Origin Establishment Timing Setting	Set the timing for establishing the origin of the axis connected to the absolute encoder. 0: When servo is locked 1: When communications is established.	0, 1	—	0

6-4 Axis Parameters

Axis parameters are used to set the maximum speed, jogging/inching settings, origin search settings, and other items that are related to axis operation for each axis controlled by the PCU.

There are axis parameters for each PCU axis. There are two axes for CJ1W-NC281 PCUs, four axes for CJ1W-NC481/482 PCUs, eight axes for CJ1W-NC881/ 882 PCUs, and 16 axes for CJ1W-NCF81/ F82 PCUs.

The parameter settings are the same for all axes. This section describes only the parameters for axis 1.



Precautions for Correct Use

When connecting to devices other than OMNUC G5-series Servo Drives, only the axis type is enabled.

Axis Parameter Table

Axis parameters are available for each axis, and you must set them for each axis.

General name	Parameter name	Reference page	Update timing
Axis Type Setting	Axis Type	6-32	At PCU startup, PCU restart, or PCU setup
I/O Function Settings	I/O Function Selection	6-34	
	Limit Input Stop Method	6-34	
	Drive Alarm Reset Output Time	6-35	
	Positioning Monitoring Time	6-35	
Acceleration/Deceleration Settings	Maximum Speed	6-36	
	Starting Speed		
	Operation at Reverse Rotation Command		
	Acceleration/Deceleration Curve Selection		
	Acceleration/Deceleration Time Selection		
	Single Axis Deceleration Time at Interpolation		Continuously

General name	Parameter name	Reference page	Update timing
Output Settings	Output Direction	6-39	At PCU startup, PCU restart, or PCU setup
Command Position Unit Settings	Axis Feeding Mode	6-40	
	Rotation Axis Upper Limit		
	Displayed Unit		
	Command Pulse Count Per Motor Rotation		
	Work Travel Distance Per Motor Rotation		
	Unit Multiplier		
	Starting Present Position Clear Enable Selection	6-45	
Software Limit Settings	Software Limit Function Selection	6-46	Continuously
	Reverse Software Limit		
	Forward Software Limit		
Zone Settings	Zone 0 Function Selection	6-48	
	Zone 0 Lower Limit		
	Zone 0 Upper Limit		
	Zone 1 Function Selection		
	Zone 1 Lower Limit		
	Zone 1 Upper Limit		
	Zone 2 Function Selection		
	Zone 2 Lower Limit		
	Zone 2 Upper Limit		
Interrupt Feeding Setting	Error Enable for Undetected Interrupt Input	6-50	
	Interrupt Feeding Amount		
Origin Search Settings	Origin Search Operation Mode	6-51	
	Operation at Forward Limit Input		
	Operation at Reverse Limit Input		
	Origin Search Start Direction		
	Origin Input Detection Direction		
	Origin Search Holding Time		
	Origin Input Mask Amount		
	Origin Compensation Value		
	Origin Position Offset		
	Origin Search Speed		
	Origin Search Approach Speed		
	Origin Search Compensation Speed		
	Origin Search Acceleration Time		
	Origin Search Deceleration Time		

6-4 Axis Parameters

General name	Parameter name	Reference page	Update timing	
Origin Return Settings	Origin Return Speed	6-55	Continuously	
	Origin Return Acceleration Time			
	Origin Return Deceleration Time			
Jogging/Inching Settings	Inching Width	6-56		
	Jogging/Inching Speed 1			
	Jogging/Inching Speed 2			
	Jogging Acceleration Time			
	Jogging Deceleration Time			
Feedback Input Settings	Encoder Type	6-57		At PCU startup, PCU restart, or PCU setup
	Absolute Encoder Origin Position Offset			At origin confirmation
Torque Settings	Maximum Torque	6-58	At PCU startup, PCU restart, or PCU setup	
Expanded Monitor Settings	Expanded Monitor Type	6-59	Continuously	
	Expanded Monitor 2 Type			
	Expanded Monitor 3 Type			
	Expanded Monitor 4 Type			
	Expanded Monitor 5 Type			
	Expanded Monitor 6 Type			
Deviation Monitor Function Settings	Deviation Monitor Setting	6-61		
	Feedback Speed Sampling Cycle			
	Speed Deviation Monitor Dwell Time			
	Speed Deviation Limit Value			
	Position Deviation Limit Value			
Positioning Completed Width Setting	Positioning Completed Width	6-63		

General name	Parameter name	Reference page	Update timing
Synchronization Settings	Synchronous Group Stop Selection	6-64	At PCU startup, PCU restart, or PCU setup
	Synchronous Feeding Position Function Selection	6-66	Continuously
	Synchronous Feeding Velocity Function Selection	6-66	
	Synchronous Feeding Torque Function Selection	6-67	
	Synchronous Feeding Torque Option Selection	6-67	
	Synchronous Feeding Velocity Limitation Option	6-68	
	Auxiliary Axis Option Settings	6-69	
	Synchronous Feeding Position Master Axis Multiplier	6-69	
	Synchronous Feeding Position Filter Constant	6-70	

Axis Type Setting

Set the axis type. When an unused axis or virtual axis is selected, I/O wiring is not necessary. The axis type setting is updated when the power supply is turned ON, the PCU is restarted, or the PCU is set up.

Parameter name	Function	Setting range	Unit	Default value
Axis Type	Set the axis type. 0: Physical axis, 2: Unused axis	0, 2	–	0



Precautions for Correct Use

The Axis Type parameter specifies axis usage. The parameter, however, does not affect the network configuration.

The network configuration information is based on the network configuration that was created with the CX-Programmer.

Refer to *Relationship between Axes and Slaves* on page 2-8 for details on the Axis Type and network configuration information.

Virtual Axes

The PCU will treat an axis as a virtual axis if the Axis Type parameter is set to 0 (physical axis) and one of the following settings is made.

- ♦ The slave is not registered in the network configuration information.
- ♦ An OMNUC G5-series Servo Drive is registered but disabled as a slave.

A virtual axis is used only for calculations. Unlike a physical axis, no real I/O is performed for it. A virtual axis changes its present position and status based on commands for axis operation in the same way as for a physical axis, but the changes occur only in the PCU.

The machine origin for a virtual axis can be defined by changing the Present Position Preset Bit to any specified value using a present position preset.

In addition, it is possible to use a virtual axis as a rotation axis by setting the Axis Feeding Mode parameter to "rotation axis (infinite length)" in the Command Position Unit Settings.

A virtual axis is different from a physical axis in the following ways.

- ♦ For a virtual axis, the command present position is the only present position. That is, the feedback present position value is always the same as the command present position.
- ♦ Origin searches and interrupt feeding cannot be performed for virtual axes. Also, the present position cannot be latched.
- ♦ There is no servo unlock status. The servo is always locked for virtual axes.
- ♦ When the Synchronous Feeding Velocity command is executed to a virtual axis, neither the command present position nor feedback present position changes and the virtual axis retains the present command speed only. That is, the feedback present speed value is always the same as the command present speed.
- ♦ When the Synchronous Feeding Torque command is executed to a virtual axis, neither the command present position nor feedback present position changes and the virtual axis retains the command torque data only. That is, the present torque value is always the same as the command torque value.



Precautions for Correct Use

- ♦ When an origin search or interrupt feeding is started for a virtual axis, the axis will continue moving because there are no external input signals, such as an origin input or an interrupt input. To set the machine origin for a virtual axis, use the Present Position Preset Bit.
 - ♦ The present position latch function cannot be used for a virtual axis.
-

I/O Function Settings

I/O Function Selections

Select the functions of the I/O signals.

The I/O function selections are updated when the power supply is turned ON, the PCU is restarted, or the PCU is set up.

Parameter name	Function	Setting range	Unit	Default value
Origin Proximity Input Signal Selection ^{*1}	Select the input to use as the origin proximity input. 0: Use the Origin Proximity Input Internal Memory Area Bits as the origin proximity inputs. 1: Use an external origin proximity input.	0 to 1	–	1
Origin Input Signal Selection	Select the input to use as the origin input. 0: Use the Z-phase input as the origin input. 1: Use an external origin input. ^{*2}	0 to 1	–	0
Interrupt Input Function ^{*3 *4}	Select the function of the interrupt input. 0: Use as an interrupt feeding trigger. 1: Use as a present position latch signal.	0 to 1	–	0

*1. If the Origin Proximity Input Signal Selection parameter is set to 0, Origin Proximity Input Internal Memory Area Bits 0 to 15 will correspond to the origin proximity inputs for axes 1 to 16. This setting is disabled for virtual axes.

*2. When using an OMNUC G5-series Servo Drive, the external origin input is allocated to latch 1 of the Servo Drive. The allocation of latch 1 can be changed using a servo parameter object in the Servo Drive. Refer to *OMNUC G5-series AC Servomotors/Servo Drives with Built-in EtherCAT Communications User's Manual* (Cat. No. I573) for details.

*3. This setting is disabled for a virtual axis.

*4. When using an OMNUC G5-series Servo Drive, the interrupt input is allocated to latch 2 of the Servo Drive. The allocation of latch 2 can be changed using a servo parameter object in the Servo Drive. Refer to *OMNUC G5-series AC Servomotors/Servo Drives with Built-in EtherCAT Communications User's Manual* (Cat. No. I573) for details.

Limit Input Stop Method

Parameter name	Function	Setting range	Unit	Default value
Limit Input Stop Method	Select the function to be implemented when a forward/reverse limit signal is input. 0: Immediate stop of reference output (Deviation pulse stop) 1: Deceleration stop of reference output 2: Immediate stop of reference output, and deviation counter reset 3: Immediate stop of reference output, deviation counter reset, and servo unlocked. 4: Immediate stop of reference output, and servo unlocked	0 to 4	–	0

Drive Alarm Reset Output Time

Parameter name	Function	Setting range	Unit	Default value
Drive Alarm Reset Output Time *1	Set the automatic output time when the Drive Alarm Reset Bit is turned ON (when resetting errors).	1 to 1,000	ms	200

*1. This setting is disabled for a virtual axis.

Positioning Monitoring Time

Parameter name	Function	Setting range	Unit	Default value
Positioning Monitoring Time *1	Set the monitoring time to be applied when monitoring the positioning completed input. If you set 0 ms, the positioning completed signal is not monitored. During an origin search, the PCU continues to wait for a positioning completed input when the origin input is detected. The positioning completed input is not monitored for the origin compensation operation. If you set any value other than 0, an error will occur if the specified time is exceeded.	0 to 10,000	ms	0

*1. This setting is disabled for a virtual axis.



Precautions for Correct Use

If you set the Positioning Monitoring Time axis parameter to 0, arrival will not be monitored for the Servo Drive feedback position. To monitor when the feedback position from the Servo Drive for the command position arrives within the positioning completed width in order to determine when the positioning operation is completed, set the Positioning Monitoring Time axis parameter to a value other than 0. Refer to *10-6 Positioning Completion* for details.



Reference

The positioning completed signal is not monitored for the following operations.

- ◆ Jogging
- ◆ Deceleration stop
- ◆ Error stop
- ◆ When reversing for origin searches, multi-starting, or interrupt feeding

Acceleration/Deceleration Settings

Set the maximum speed, starting speed, acceleration/deceleration time settings, etc.

The speed and acceleration/deceleration setting parameters become valid at PCU startup, PCU restart, or PCU setup, except for deceleration time designation. Deceleration time designation is continuously updated.

Parameter name	Function	Setting range	Unit	Default value
Maximum Speed	Specify the maximum speed for the axis.	1 to 2,147,483,647	Command units/s	4,000,000
Starting Speed	Specify the starting speed for the axis.	0 to 2,147,483,647	Command units/s	0
Operation at Reverse Rotation Command	Select the operation for reversing rotation for multi-starting. 0: Deceleration stop for reverse rotation, 1: Immediate stop for reverse rotation	0 to 1	—	0
Acceleration/Deceleration Curve Selection	Select the acceleration/deceleration curve. 0: Trapezoid, 1: S-curve (tertiary curve)	0 to 1	—	0
Acceleration/Deceleration Time Selection	Set how to specify the acceleration/deceleration time. 0: Time from starting speed to maximum speed of each axis (constant acceleration/deceleration rate) 1: Time from present speed to target speed of each axis (constant acceleration/deceleration time)	0 to 1	—	0
Single Axis Deceleration Time at Interpolation	Set the deceleration stop time to be applied when an error occurs in any of the interpolated axes or an individual deceleration stop is executed during interpolation operation in memory operation.	0 to 250,000	ms	1,000

Maximum Speed

Set the fastest speed to actually use. This prevents you from inadvertently using speeds exceeding the maximum speed.

Although the upper limit of the setting range of the maximum speed is 2,147,483,647, it cannot be set to a value that would exceed 104,857,600 pps when converted to pulses.



Reference

Refer to *Axis Parameter Settings* on page 4-5 for the method to calculate the maximum speed.

Starting Speed

An OMNUC G5-series Servomotor will be used, so set the starting speed to 0.

Operation at Reverse Rotation Command

Select the method to use to stop the axis that reverses due to multi-starting.

Patterns When a Deceleration Stop Is Set for Reverse Rotation Command

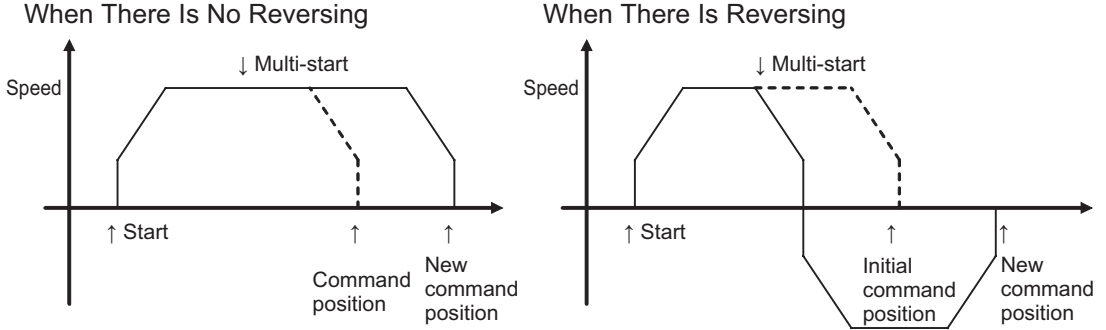

Patterns When an Immediate Stop Is Set for Reverse Rotation Command

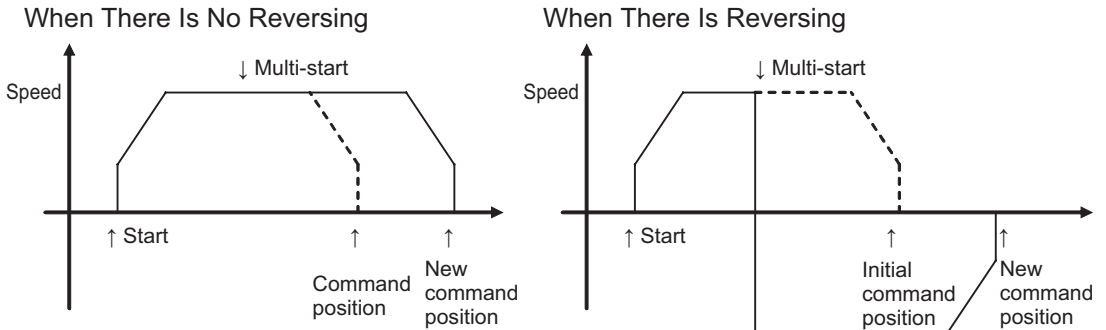

Acceleration/Deceleration Curve Selection

Select the acceleration/deceleration curve.

Trapezoid

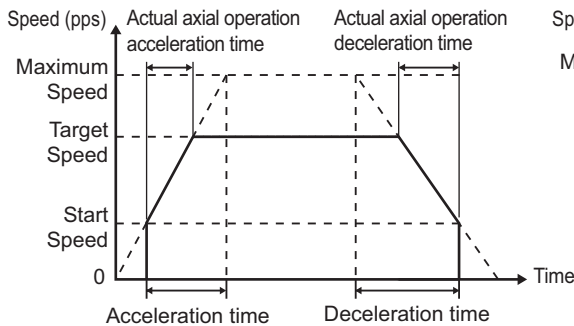

S-curve

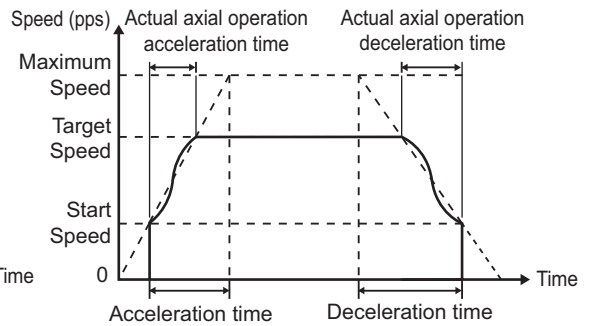

Acceleration/Deceleration Time Selection

Select the method for the acceleration/deceleration time designation method. You can specify a constant acceleration/deceleration rate or a constant acceleration/deceleration time.

With a constant acceleration/deceleration rate, the acceleration/deceleration time is the time from the starting speed to the maximum speed. With this setting, the acceleration/deceleration time changes according to the target speed.

With a constant acceleration/deceleration time, the acceleration/deceleration time is the time from the present speed to the target speed. With this setting, the acceleration/deceleration time will not change. For triangle control, however, the acceleration/deceleration time is based on the acceleration that is calculated from the present speed, target speed, and acceleration/deceleration time.

Constant Acceleration Rate

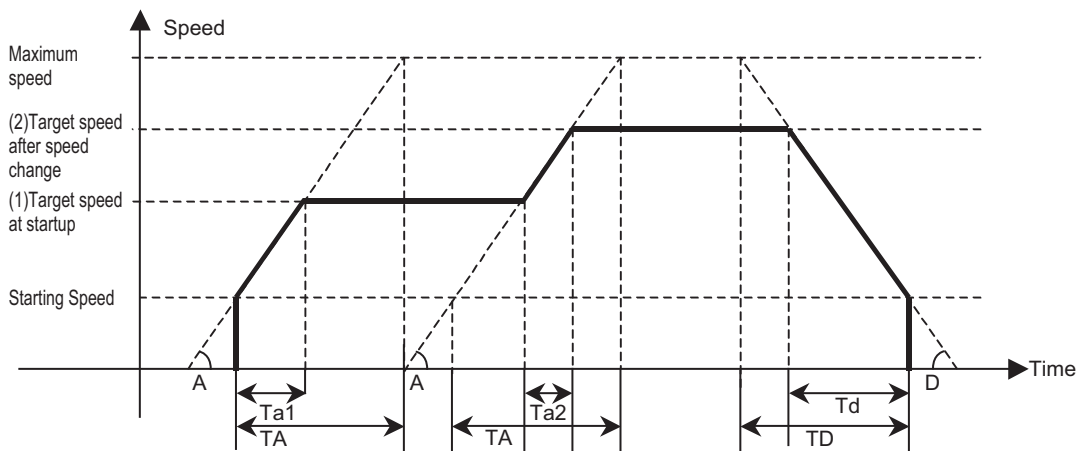

At Startup

TA: Acceleration time
 Ta1: Actual acceleration time
 A: Acceleration rate

For Speed Changes

TA: Acceleration time
 Ta2: Actual acceleration time
 A: Acceleration rate

During Deceleration

TD: Deceleration time
 Td: Actual deceleration time
 D: Rate of deceleration

Constant Acceleration/Deceleration Time

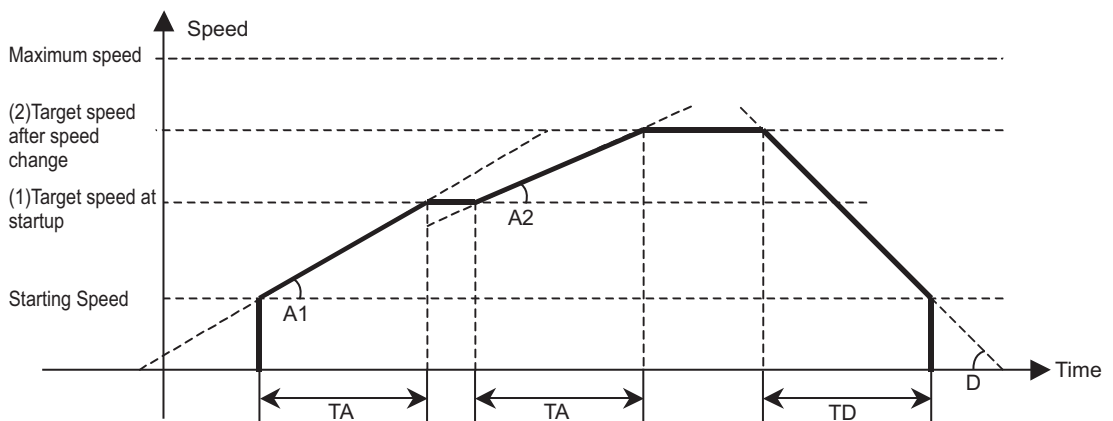

At Startup

TA: Acceleration time
 A1: Acceleration rate

For Speed Changes

TA: Acceleration time
 A2: Acceleration rate

During Deceleration

TD: Deceleration time
 D: Rate of deceleration

**Reference**

- ♦ The axis always rotates at a constant acceleration/deceleration rate during origin searches regardless of the setting of Acceleration/Deceleration Time Selection parameter.
- ♦ If a software limit is exceeded in one of the following operations or an overflow occurs in the present command position, the deceleration time will be shorter.
 - ♦ Deceleration stop due to turning OFF a Jogging Bit
 - ♦ Deceleration stop due to reversing during jogging
 - ♦ Deceleration stop due to reversing for a command change during direct operation

Single Axis Deceleration Time at Interpolation

Set the deceleration time to be applied when you select a deceleration stop for the Interpolation Axis Stop Method memory operation parameter. For the setting, refer to *Interpolation Axis Stop Method* on page 6-73.

This time is used for a deceleration stop if an error occurs in any of the interpolated axes or an individual deceleration stop command is executed during interpolation of memory operation.

Output Settings

Set the rotation direction of the Servomotor.

Output setting is updated when the power supply is turned ON, the PCU is restarted, or the PCU is set up.

Parameter name	Function	Setting range	Unit	Default value
Output Direction	Set the rotation direction of the Servomotor. 0: Forward rotation for positive command values 1: Reverse rotation for positive command values	0 to 1	–	0

Output Direction

You can change the rotation direction of the motor without changing the wiring.

Command Position Unit Setting

Select the coordinate system and unit for command positions.

The command position unit settings are updated when the power supply is turned ON, the PCU is restarted, or the PCU is set up.

Parameter name	Function	Setting range	Unit	Default value
Axis Feeding Mode	Select the counting mode for the command position. 0: Linear axis (finite length), 1: Rotation axis (infinite length)	0 to 1	–	0
Rotation Axis Upper Limit	Set the rotation axis upper limit when you set the Axis Feeding Mode to a rotation axis.	1 to 1,073,741,823 ^{*1}	Command units	1,073,741,823
Displayed Unit	Select the unit for command values. 0: Pulses, 1: mm, 2: Degrees, 3: Inches	0 to 3	–	0
Command Pulses Count Per Motor Rotation	Set the number of pulses per motor rotation.	1 to 4,294,967,295 ^{*2}	Pulses	10,000
Work Travel Distance Per Motor Rotation	Set the amount of workpiece movement per motor rotation.	1 to 4,294,967,295 ^{*2}	Displayed Unit	10,000
Unit Multiplier	Set the ratio relative to the amount of the workpiece movement when the motor makes 1 rotation. 0: x1, 1: x10, 2: x100, 3: x1,000, 4: x10,000	0 to 4	–	0
Starting Present Position Clear Enable	Select whether to enable or disable the preset function. 0: Disabled, 1: Enabled	0 to 1	–	0

*1. This parameter can be set in command units, but the setting must not exceed 1,073,741,823 pulses when converted to pulses.

*2. The setting range for PCUs of version 1.1 or earlier is 1 to 1,048,576.

Axis Feeding Mode

Linear Axis (Finite Length)

- ♦ A linear counter with a range of -2,147,483,648 to 2,147,483,647 centered around 0 is used.
- ♦ In position control, a command for which the counter value overflows will cause an error and the command will not be executed.
- ♦ The above error will also occur when the interrupt input is received during interrupt feeding.
- ♦ In speed control, a overflow/underflow warning occurs when the present position overflows/underflows the counter value, but operation continues. Here, the counter value is locked at the maximum value.
- ♦ While the counter value is locked, only jogging commands in the reverse direction will be acknowledged. A command to start any other operation will cause an error at start.
- ♦ The counter value will remain locked until you clear the overflow/underflow status.
- ♦ To clear the overflow/underflow status, you must perform an origin search or present position preset.
- ♦ The overflow/underflow values depend on the electronic gear setting.

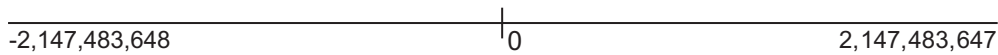

Precautions for Correct Use

- ♦ Depending on the command position unit settings, an overflow or underflow may occur even if the command value is within the above range of -2,147,483,648 to 2,147,483,647. The number of pulses must not exceed the setting range.

Rotation Axis (Infinite Length)

- ♦ A ring counter with a maximum value of 1,073,741,823 is used (infinite axis).
- ♦ If 0 (shortest route), 1 (forward), or 2 (reverse) is specified as the Rotation Axis Direction for an absolute movement command, an error will occur if a command value exceeding the rotation axis upper limit is set. If 3 (not specified) is specified as the Rotation Axis Direction for an absolute movement command or if a relative movement command is used, multiple rotations will be supported if a command value that exceeds the rotation axis upper limit is set.

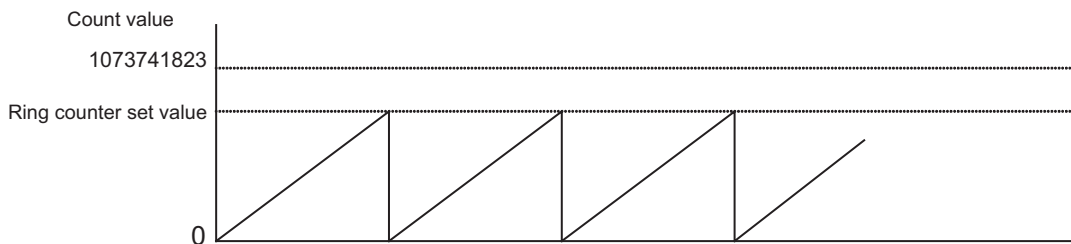

Precautions for Correct Use

- ♦ Even command values that are between 0 and 1,073,741,823 can result in errors depending on the command unit set for the command position unit settings. The number of pulses must not exceed the setting range.

Rotation Axis Upper Limit

This parameter is valid when you set the Axis Feeding Mode parameter to specify a rotation axis.

Set the upper limit for the rotation axis.

Displayed Unit

Select the unit for commands.

Position data and other data will not be reconverted when you change the unit.

Command Pulse Count Per Motor Rotation

Set the number of pulses per motor rotation.

Work Travel Distance Per Motor Rotation

Set the amount of the workpiece movement per motor rotation.

Using a Reducer

If a reducer is being used, consider the gear ratio of the reducer in the number of motor rotations when setting command pulses and travel distances.

For example, calculations would be as follows when using a gear ratio of 1/9 for a motor with a resolution of 10000 pulses per rotation and a machine operating pitch of 6 mm:

Number of command pulses per machine rotation (9 motor rotations) = $10000 \times 9 = 90000$ pulses per rotation

Travel distances per machine rotation (9 motor rotations) = 6 mm

Set the Command Pulse Count Per Motor Rotation and Work Travel Distance Per Motor Rotation parameters to these values.

When the Work Travel Distance Per Motor Rotation Is Not an Integer

The Work Travel Distance Per Motor Rotation parameter is set as an integer. If the work travel distance per motor rotation is not an integer, adjust the command pulses and travel distance so that the travel distance will become an integer.

For example, if the work travel distance per motor rotation is 10.1 mm for a motor with a resolution of 10,000 pulses per rotation, the command pulses and travel distance are each multiplied by 10 so that the travel distance becomes an integer.

Number of command pulses per 10 motor rotations = $10,000 \times 10 = 100,000$ pulses per rotation

Work travel distance per 10 motor rotations = $10.1 \times 10 = 101$ mm

Set the Command Pulse Count Per Motor Rotation and Work Travel Distance Per Motor Rotation parameters to these values.

When the Number of Command Pulses Per Motor Rotation Exceeds the Setting Range

If the setting range of the Command Pulse Count Per Motor Rotation parameter is exceeded because a reducer is used or because the travel distance per motor rotation is not an integer, reduce the settings of the Command Pulse Count Per Motor Rotation and Work Travel Distance Per Motor Rotation parameters by the same factor so that the setting range is not exceeded.

For example, calculations would be as follows when using a gear ratio of 1/5 for a motor with a resolution of 1,048,576 pulses per rotation and a machine operating pitch of 10 mm:

Number of command pulses per machine rotation (5 motor rotations) = $1048576 \times 5 = 5242880$ pulses per rotation

Travel distances per machine rotation (5 motor rotations) = 10 mm

Thus the setting range of the Command Pulse Count Per Motor Rotation parameter (1 to 1,048,576) is thus exceeded.

Here, convert the values by a factor (e.g., 1/5) that would bring the setting into range.

Number of command pulses per 1/5 motor rotation = $5,242,880 \div 5 = 1,048,576$ pulses per rotation

Work travel distance per 1/5 motor rotation = $10 \div 5 = 2$ mm

Set the Command Pulse Count Per Motor Rotation and Work Travel Distance Per Motor Rotation parameters to these values.

Unit Multiplier

Set the ratio relative to the amount of the workpiece movement when the motor makes 1 rotation. A unit multiplier can be set to change the minimum command unit (i.e., the number of digits below the decimal point in command values).

Setting a Command Unit of 1 mm

If the movement per motor rotation is 6 mm and you want to rotate the motor once with a command unit of 1 mm, set the Work Travel Distance Per Motor Rotation parameter to 6 and the Unit Multiplier parameter to 0 (x1). With these settings, the motor will rotate once for a position command of 6.

Setting a Command Unit of 0.01 mm

If the movement per motor rotation is 6 mm and you want to rotate the motor once with a command unit of 0.01mm, set the Work Travel Distance Per Motor Rotation parameter to 6 and the Unit Multiplier parameter to 2 (x100). With these settings, the motor will rotate once for a position command of 600.



Precautions for Correct Use

- ♦ If the Axis Feeding Mode parameter is set to Rotation Axis, set the pulse unit so that the number of pulses in one rotation can be divided evenly by the specified pulse unit. Specifically, if the setting of the Rotation Axis Upper Limit parameter plus one (command units) is converted to pulses, the number of pulses must be an integer. If the number of pulses in one rotation is not an integer, the decimal portion will be truncated, causing a position offset. If there is a decimal portion, the command present value will not be displayed correctly.
- ♦ The setting ranges for the following parameters differ depending on the command position unit settings. The number of pulses must not exceed the setting range for each parameter.

♦ Origin Input Mask Amount	♦ Maximum Speed	♦ Rotation Axis Upper Limit
♦ Origin Compensation Value	♦ Starting Speed	♦ Software Limit
♦ Origin Position Offset	♦ Zone	♦ Inching Width
♦ Origin Search Speed	♦ Interrupt Feeding Amount	♦ Origin Search Approach Speed
♦ Origin Search Compensation Speed	♦ Origin Return Speed	♦ Jogging/Inching Speed
- ♦ Depending on the command position unit settings, an overflow or underflow may occur even if the command value is within the above range of -2147483648 to 2147483647. The number of pulses must not exceed 32 bits.



Reference

The following figure shows how a PCU converts the command position unit settings into the number of output pulses and pulse speed and the number of input pulses into the feedback present position.

All command values and parameters specified in command units or command units/s are converted in this way.

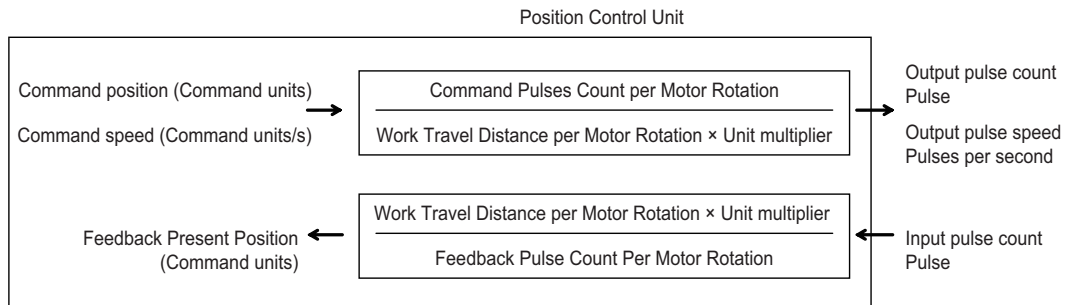

The command position after converted into pulses is a signed 32-bit value between - 2,147,483,648 and - 2,147,483,647. Similarly, the command speed is up to 1,048,576 pps after converted into pulses per second.

The compensation factor is applied to output pulses only.

Starting Present Position Clear Enable Setting

Select the function to use to preset the present position to 0 at the start of positioning.

For details on the starting preset setting, refer to *5-4 Present Position Preset* on page 5-44.

Software Limit Settings

Select the software limit function. This function is enabled only in Linear Mode.

Software limit settings are continuously updated.

For multi-starting in direct operation or when the end pattern is set to continuous 1 to 3 in memory operation, the settings at the start of axis operation are retained.

Parameter name	Function	Setting range	Unit	Default value
Software Limit Function Selection	Select the software limit function. 0: Disabled 1: Enabled for command positions. Disabled for adjustment operations.*1 2: Enabled for feedback positions. Disabled for adjustment operations.*1 3: Enabled for command positions and adjustment operations.*1 4: Enabled for feedback positions and adjustment operations.*1	0 to 4	–	0
Reverse Software Limit	Set the software limit value in the reverse direction.	-2,147,483,647 to 2,147,483,646*2	Command units	-2,147,483,647
Forward Software Limit	Set the software limit value in the forward direction.	-2,147,483,647 to 2,147,483,646*2	Command units	2,147,483,646

*1. Adjustment operations include jogging and inching.

*2. This parameter can be set in command units, but the setting must not exceed the above range when converted to pulses.

Software Limit Function

This function monitors positioning points in the software, separately from hardware limit signals, in order to prevent damage to external devices that may result from an unexpected positioning operation due to incorrect operation.

Set the range to be monitored by software limits using two values, i.e., the reverse limit and the forward limit.

During normal positioning, positioning is performed within the range of these software limits.

If the present position goes outside the specified range because of a command that does not cause movement, such as a present position preset, the software limit is not detected.

If the present position is outside the range of the software limits, you can perform positioning only toward the range of software limits.

The software limits do not operate unless the origin is defined. Therefore, software limits are not detected while an origin search operation is in progress.

The software limits are enabled for linear axes (finite lengths).

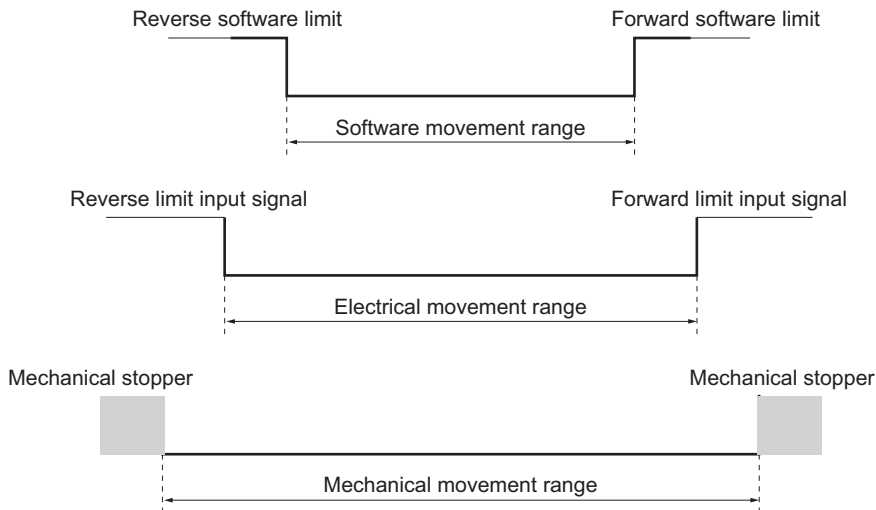

Precautions for Correct Use

- ♦ The software limit settings (enable/disable and limit values) are constantly updated. If you change the settings during axis operation, however, the new settings are used only when the next axis operation starts.

Also, changes to the software limit settings are not updated for interpolation operation pattern changes from continuous 1, continuous 2, or continuous 3.

- ♦ Depending on the command position unit settings, an overflow or underflow may occur even if the command value is within the above range of -2,147,483,647 to 2,147,483,646. The number of pulses must not exceed the setting range.

Zone Settings

The zone setting function notifies the PLC when the present position of the machine is inside a specified zone. You can set three zones for each axis.

Zone settings are continuously updated.

Parameter name	Function	Setting range	Unit	Default value
Zone 0 Function Selection	Select the function for zone 0. 0: Disabled 1: Enabled for command positions. 2: Enabled for feedback positions.	0 to 2	–	0
Zone 0 Lower Limit	Set the set value for the reverse direction of zone 0.	-2,147,483,648 to 2,147,483,647 ^{*1}	Command units	0
Zone 0 Upper Limit	Set the set value for the forward direction of zone 0.	-2,147,483,648 to 2,147,483,647 ^{*1}	Command units	0
Zone 1 Function Selection	Select the function for zone 1. 0: Disabled 1: Enabled for command positions. 2: Enabled for feedback positions.	0 to 2	–	0
Zone 1 Lower Limit	Set the set value for the reverse direction of zone 1.	-2,147,483,648 to 2,147,483,647 ^{*1}	Command units	0
Zone 1 Upper Limit	Set the set value for the forward direction of zone 1.	-2,147,483,648 to 2,147,483,647 ^{*1}	Command units	0
Zone 2 Function Selection	Select the function for zone 2. 0: Disabled 1: Enabled for command positions. 2: Enabled for feedback positions.	0 to 2	–	0
Zone 2 Lower Limit	Set the set value for the reverse direction of zone 2.	-2,147,483,648 to 2,147,483,647 ^{*1}	Command units	0
Zone 2 Upper Limit	Set the set value for the forward direction of zone 2.	-2,147,483,648 to 2,147,483,647 ^{*1}	Command units	0

*1. This parameter can be set in command units, but the setting must not exceed the above range when converted to pulses.

Zone Function

The zone setting function notifies the CPU Unit when the present position of the machine is inside a specified zone. Zone flags are used to notify the CPU Unit.

This function is generally used to create interlocks with peripheral devices, perform synchronous operation, etc., depending on the present position of the machine.

The zones do not necessarily have to be set within the software limits.

The zone function operates regardless of whether or not the origin is defined or an error has occurred.

There are three Zone Flags for each axis. You can set each zone individually.



Reference

- ♦ For details on the Zone Flags, refer to *Axis Status Memory Area* on page 6-100.

If you use the zone function, you must set the lower limit and upper limit, as shown below.

Linear Axis

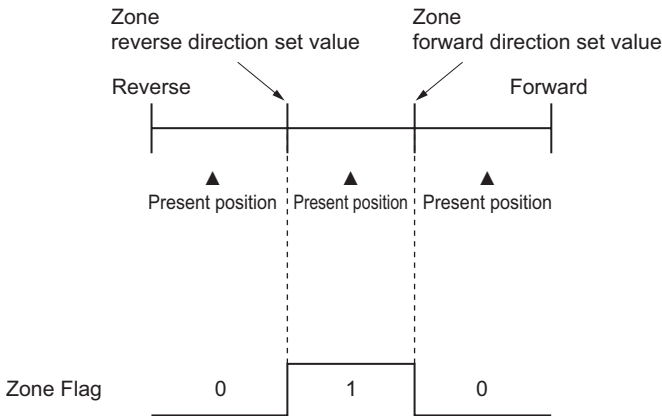

Precautions for Correct Use

- ♦ In Linear Mode, an error occurs if you set the lower limit greater than the upper limit.

Rotation Axis

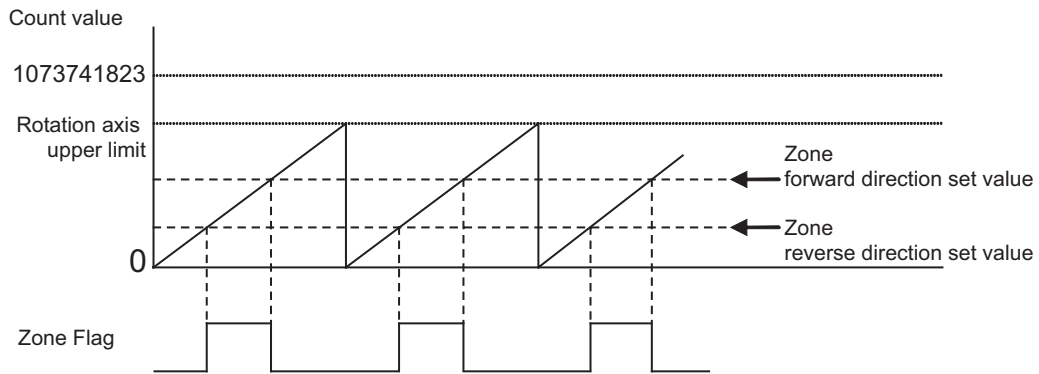

Reference

- With a rotation axis, you can set the lower limit value greater than the upper limit, in order to set a zone that crosses 0.
- Depending on the command position unit settings, an overflow or underflow may occur even if the command value is within the above range of -2,147,483,648 to 2,147,483,647. The number of pulses must not exceed the setting range.

Interrupt Feeding Settings

Set the data for interrupt feeding during direct operation.

For details on interrupt feeding, refer to *10-2 Interrupt feeding* on page 10-7.

To set data for interrupt feeding during memory operation, refer to *Interrupt Feeding for Positioning Operation* on page 8-36.

The interrupt feeding setting is continuously updated.

Parameter name	Function	Setting range	Unit	Default value
Error Enable for Undetected Interrupt Input	Select whether to output an error when an interrupt input is not received before positioning is completed during interrupt feeding for position control. 0: Without error detection 1: With error detection	0 to 1	—	0
Interrupt Feeding Amount	Set the amount of movement for interrupt feeding.	-2,147,483,648 to 2,147,483,647 ^{*1}	Command units	0

*1. This parameter can be set in command units, but the setting must not exceed the above range when converted to pulses.



Precautions for Correct Use

- Depending on the command position unit settings, an overflow or underflow may occur even if the command value is within the above range of -2,147,483,648 to 2,147,483,647. The number of pulses must not exceed the setting range.

Origin Search Settings

Set the motor operation data that you use to determine the mechanical origin.

Origin Search setting is continuously updated.

Parameter name	Function	Setting range	Unit	Default value
Origin Search Operation Mode	Select the method to define the origin. 0: Proximity reverse turn/origin proximity input OFF 1: Proximity reverse turn/origin proximity input ON 2: Proximity reverse turn/origin proximity Input OFF (approach speed after reverse turn) 3: Proximity reverse turn/origin proximity input ON (approach speed after reverse turn) 4: Origin proximity input OFF 5: Origin proximity input ON 6: Origin reverse turn/no origin proximity input 7: No origin proximity input 8: Limit input OFF 9: Proximity reverse turn/origin input mask amount 10: Origin proximity input only 11: Proximity reverse turn/holding time 12: Proximity reverse turn/holding origin input 13: No origin proximity input/holding origin input 14: Origin preset	0 to E	–	0
Operation at Forward Limit Input	Select the operation to be performed when the reverse limit input in the operating direction turns ON during an origin search. 0: No reverse turn, error stop ^{*1} 1: Reverse turn, deviation pulse stop 2: Reverse turn, deceleration stop	0 to 2	–	1
Operation at Reverse Limit Input	Select the operation to be performed when the reverse limit input in the operating direction turns ON during an origin search. 0: No reverse turn, error stop ^{*1} 1: Reverse turn, deviation pulse stop 2: Reverse turn, deceleration stop	0 to 2	–	1
Origin Search Start Direction	Select the starting direction for an origin search. 0: Forward, 1: Reverse	0 to 1	–	0
Origin Input Detection Direction	Select the origin input detection direction for an origin search. 0: Forward, 1: Reverse	0 to 1	–	0
Origin Search Holding Time	Set the holding time when you set the Origin Search Operation Mode to Proximity Reverse Turn/Holding Time.	0 to 10,000	ms	100
Origin Input Mask Amount	Set the feeding amount when you set the Origin Search Operation Mode to Proximity Reverse Turn/Origin Input Mask Amount.	0 to 2,147,483,647 ^{*2}	Command units	10,000
Origin Compensation Value	Set the origin search compensation amount that is applied after the origin is determined.	-2,147,483,648 to 2,147,483,647 ^{*2}	Command units	0

Parameter name	Function	Setting range	Unit	Default value
Origin Position Offset	Preset the present position for the value that is set after starting an origin search.	-2,147,483,648 to 2,147,483,647*2	Command units	0
Origin Search Speed	Set the high speed during an origin search.	1 to 2,147,483,647	Command units/s	10,000
Origin Search Approach Speed	Set the proximity speed during an origin search.	1 to 2,147,483,647	Command units/s	1,000
Origin Search Compensation Speed	Set the compensation speed during an origin search.	1 to 2,147,483,647	Command units/s	1,000
Origin Search Acceleration Time	Set the acceleration time during an origin search.	0 to 250,000	ms	1,000
Origin Search Deceleration Time	Set the deceleration time during an origin search.	0 to 250,000	ms	1,000

*1. The error stopping method depends on the limit input stopping method.

*2. This parameter can be set in command units, but the setting must not exceed the above range when converted to pulses.

Origin Search Operation Mode

Select one of the fifteen operations to define the mechanical origin. For details, refer to *Origin Search Operations* on page 5-26.

Operation at Forward Limit Input and Operation at Reverse Limit Input

Select whether to reverse the axis and continue with the origin search, or to not reverse the axis, create an error, and stop the axis, when the axis reaches a limit input in the operating direction during an origin search. To reverse the axis, also select the stopping method.

An error will occur and operation will stop if you set reversing for the limit input operation in both directions and the origin cannot be detected after moving from the limit input position opposite to the origin input detection direction to the other limit input position.

Origin Search Start Direction

Select the direction in which the axis starts moving when an origin search is started. For details, refer to *Origin Search Start Direction* on page 5-23.

Origin Input Detection Direction

Select the direction for detecting the origin input. For details, refer to *Origin Input Detection Direction* on page 5-24.

Origin Search Holding Time

Set the holding time when you set the Origin Search Operation Mode to Proximity Reverse Turn/Holding Time.

For details, refer to *Proximity Reverse Turn and Holding Time (Setting: 11)* on page 5-36.

Origin Input Mask Amount

Set the feeding amount when you set the Origin Search Operation Mode to Proximity Reverse Turn/Origin Input Mask Amount.

For details, refer to *Proximity Reverse Turn and Origin Input Mask Amount (Setting: 9)* on page 5-34.



Precautions for Correct Use

- ◆ Depending on the command position unit settings, an overflow or underflow may occur even if the command value is within the above range of 0 to 2,147,483,647. The number of pulses must not exceed the setting range.
-

Origin Compensation Value

Set the origin search compensation amount that is applied after the origin is determined.

For details, refer to *Origin Compensation* on page 5-40.



Precautions for Correct Use

- ◆ Depending on the command position unit settings, an overflow or underflow may occur even if the command value is within the above range of -2,147,483,648 to 2,147,483,647. The number of pulses must not exceed the setting range.
-

Origin Position Offset

The origin is preset to the specified offset value after the machine origin has been defined for an origin search.



Precautions for Correct Use

- ◆ Depending on the command position unit settings, an overflow or underflow may occur even if the command value is within the above range of -2,147,483,648 to 2,147,483,647. The number of pulses must not exceed the setting range.
-

Origin Search Speed

This is the speed used for an origin search.

Origin Search Approach Speed

This is the proximity speed during an origin search.

Origin Search Compensation Speed

This is the speed when you set an origin compensation value.
For details, refer to *Origin Compensation* on page 5-40.

Origin Search Acceleration Time and Origin Search Deceleration Time

Set the acceleration time and deceleration time to use during an origin search.

The setting of the Acceleration/Deceleration Time Selection parameter determines the meaning of the Origin Search Acceleration Time and Origin Search Deceleration Time.

For details, refer to *Acceleration/Deceleration Settings* on page 6-36 and *Acceleration/Deceleration Time Selection* on page 6-38.

Origin Return Settings

Set the speed and acceleration/deceleration times to use when you return the axis from a given position to the origin after the origin has been defined.

Origin return settings are continuously updated.

Parameter name	Function	Setting range	Unit	Default value
Origin Return Speed	Set the speed for an origin return.	1 to 2,147,483,647	Command units/s	10,000
Origin Return Acceleration Time	Set the acceleration time for an origin return.	0 to 250,000	ms	1,000
Origin Return Deceleration Time	Set the deceleration time for an origin return.	0 to 250,000	ms	1,000

Origin Return Speed

Set the speed for an origin return.

Origin Return Acceleration Time and Origin Return Deceleration Time

Set the acceleration time and deceleration time for an origin return.

The setting of the Acceleration/Deceleration Time Selection parameter determines the meaning of the Origin Return Acceleration Time and Origin Return Deceleration Time.

For details, refer to *Acceleration/Deceleration Settings* on page 6-36 and *Acceleration/Deceleration Time Selection* on page 6-38.

Jogging/Inching Settings

Set the items that are necessary to perform jogging and inching.

The jogging/inching settings are continuously updated.

Parameter name	Function	Setting range	Unit	Default value
Inching Width	Set the amount of movement for inching. If you set this parameter to 0, axis operation will be the same as for jogging.	0 to 65,535*1	Command units	0
Jogging/Inching Speed 1	Set jogging/inching speed 1.	1 to 2,147,483,647	Command units/s	1,000
Jogging/Inching Speed 2	Set jogging/inching speed 2.	1 to 2,147,483,647	Command units/s	10,000
Jogging Acceleration Time	Set the acceleration time for jogging.	0 to 250,000	ms	1,000
Jogging Deceleration Time	Set the deceleration time for jogging.	0 to 250,000	ms	1,000

*1. This parameter can be set in command units, but the setting must not exceed 65535 pulses when converted to pulses.

Inching Width

Set the amount of movement per inching operation. If you set the amount of movement to 0, the axis will operate in the same way as for jogging.



Precautions for Correct Use

- Depending on the command position unit settings, an overflow or underflow may occur even if the command value is within the above range of 0 to 65535. The number of pulses must not exceed the setting range.

Jogging/Inching Speeds

These parameters are the speed commands for jogging and inching. You can set two speeds, speed 1 and speed 2, and change between these speeds during operation.

Jogging Acceleration Time and Jogging Deceleration Time

Set the acceleration time and deceleration time for jogging and inching.

The setting of the Acceleration/Deceleration Time Selection parameter determines the meaning of the Jog Acceleration Time and Jog Deceleration Time parameters.

For details, refer to *Acceleration/Deceleration Settings* on page 6-36 and *Acceleration/Deceleration Time Selection* on page 6-38.

Feedback Input Settings

These parameters set the encoder type and the offset for the absolute encoder origin position. This setting is disabled for a virtual axis.

The setting of the Encoder Type parameter is updated when the power supply is turned ON, when the PCU is restarted, or when the PCU Setup Bit is turned ON. The setting of the Absolute Encoder Origin Position Offset parameter is enabled when the origin is defined.

Parameter name	Function	Setting range	Unit	Default value
Encoder Type	0: Incremental encoder 1: Absolute encoder	0 to 1	–	0
Absolute Encoder Origin Position Offset	This parameter stores the compensation value for absolute encoder to be taken in when you execute absolute origin setting.	-2,147,483,648 to 2,147,483,647	Pulses	0

Encoder Type

Set the encoder type for the feedback input.



Precautions for Correct Use

Make sure that the Encoder Type axis parameter of the PCU matches the Motor Type of the OMNUC G5-series Servo Drive.

The Motor Type may be either Absolute Position Encoder or Incremental Encoder.

The Motor Type of an OMNUC G5-series Servo Drive is determined by the combination of the Operation Mode Switching for Absolute Encoder (3015h) Servo Drive parameter and the motor connected.

In the case of a type mismatch, the PCU operates based on the Encoder Type axis parameter.

Therefore, if an incremental encoder is used but the PCU is configured to use an absolute encoder, the PCU attempts to restore the absolute encoder's previous position when powered ON. Similarly, if an absolute encoder is used but the PCU is configured to use an incremental encoder, the PCU does not restore the previous current value when powered ON.

Absolute Encoder Origin Position Offset

This parameter stores the absolute encoder compensation value that is read when you execute absolute encoder origin setting. This parameter stores the compensation value for mechanical origin.

This set value is read-only and you cannot write it directly.

However, you can write the data by using a data transfer bit during PCU setup.



Precautions for Correct Use

- ◆ Before you select the overwrite setting, check for negative impact. Changing this parameter changes the origin position that is determined by the absolute encoder.

Torque Settings

Set the Maximum Torque parameter.

The Maximum Torque setting is updated when the power supply is turned ON, when the PCU is restarted, or when the PCU Setup Bit is turned ON.

Parameter name	Function	Setting range	Unit	Default value
Maximum Torque	Specify the maximum torque for the axis.	0 to 10,000	0.1%	3,000

Maximum Torque

The Maximum Torque parameter accepts a value not higher than the maximum output torque of the motor.

This prevents you from inadvertently using torque higher than the maximum output torque.

Even if you specify a torque value beyond the maximum output torque, the output torque to the Servo Drive will be restricted to the Maximum Torque setting.

The Maximum Torque parameter is applied to the following:

- ◆ Torque feedforward data
- ◆ Torque limit data
- ◆ Command torque data

The Maximum Torque setting is also used as the default for the positive torque limit value (60E0h) and the negative torque limit value (60E1h).

For details, refer to *10-4 Torque Limits* on page 10-19.



Precautions for Correct Use

- ♦ Also, do not set the max torque to too small a value since the torque cannot be higher than your configured value.
Carefully determine the appropriate setting especially when you use vertical axes.
- ♦ Before using a mode in which the torque limit data is modified directly from the cyclic memory area, be sure to assign the torque limit data on the Direct Operation Command Memory Area. Otherwise, the torque will not be correctly generated.
- ♦ You can use axis parameters (such as Simple Backup) created in a PCU unit version 1.1 or earlier, but the Maximum Torque axis parameter defaults to 0.
Be sure to configure the max torque whenever you use a method in which the torque limit data is configured using the Memory Area/Synchronous Data Link. Otherwise, no torque will be generated.

Expanded Monitor Settings

Select the type of expanded monitor.

Expanded monitor settings are continuously updated.

Parameter name	Function	Setting range	Unit	Default value
Expanded Monitor Type *1	Select the type of expanded monitor to use. 0: Feedback present position 1: Command present position 2: Position deviation 3: Feedback present speed 4: Command present speed 5: Present torque 6: Command torque 7: Latch 1 value 8: Latch 2 value 9: Slave error code 10: Status word 11: Feedback present speed 2 12: Command present speed 2*2	0 to 12	—	0

*1. New expanded monitor types introduced with version 1.3 include "6 (command torque data)", "8 (latch 2 value)", "11 (feedback present speed 2)", and "12 (command present speed 2)."

*2. Monitors the same value as 4 (command present speed) during linear or circular interpolation in memory operation or during the execution of the Synchronous Feeding Position function. This is 0 when unit performs synchronous feeding torque control.

Expanded Monitor Type

Select the type of expanded monitor.

The settings are the same for the Expanded Monitor 2 to 6 parameters.

When the axis type is set to a virtual axis, the command present position is used even if you select 0 (feedback present position). Similarly, the position deviation will be 0 if you select 2 (position deviation), and the present command speed is used if you select 3 (present feedback speed).

3 (present feedback speed) is used to calculate and monitor the speed from the amount of movement during the PCU control cycle.

11 (present feedback speed 2) is used to monitor the OMNUC G5-series Servo Drive's 606C hex velocity actual value (process data object). If the 606C hex velocity actual value object is not mapped, this will be 0.

4 (command present speed) is used to calculate and monitor the speed from the amount of movement during the PCU control cycle.

12 (command present speed 2) is used to monitor the speed based on the internal profile processing of the PCU.

12 (command present speed 2) provides more granular monitoring than 4 (command present speed).



Reference

- ♦ For details on the monitor value storage locations, refer to *Axis Status Memory Area* on page 6-100 and *Expanded Monitor Memory Area* on page 6-118.
- ♦ Monitor type 10 (status word) is used to monitor the OMNUC G5-series Servo Drive's status word (process data object 6041 hex).
- ♦ Refer to the *OMNUC G5-series Servo Drives with Built-in EtherCAT Communications User's Manual* (Cat. No. I573) for information on OMNUC G5-series Servo Drive process data objects.

Deviation Monitor Function Settings

Set the items that are necessary to monitor the position deviation between the command position and feedback position, and speed deviation between the command speed and feedback speed.

Error monitor function settings are continuously updated.

Parameter name	Function	Setting range	Unit	Default value
Speed Deviation Monitor Valid	Select whether to enable or disable the speed deviation monitor function. 0: Disabled, 1: Enabled	0 to 1	–	0
Position Deviation Monitor Valid	Select whether to enable or disable the position deviation monitor function. 0: Disabled, 1: Enabled	0 to 1	–	0
Feedback Speed Sampling Cycle	Set the sampling cycle at which to measure the feedback speed.	1 to 20	ms	10
Speed Deviation Monitor Dwell Time	Set the time from the start of the command speed output until the speed deviation monitor starts.	10 to 10,000	ms	1,000
Speed Deviation Limit Value	Set the speed deviation to monitor.	1 to 65,000	–	100
Position Deviation Limit Value	Set the position deviation to monitor.	1 to 65,000	Command units	100

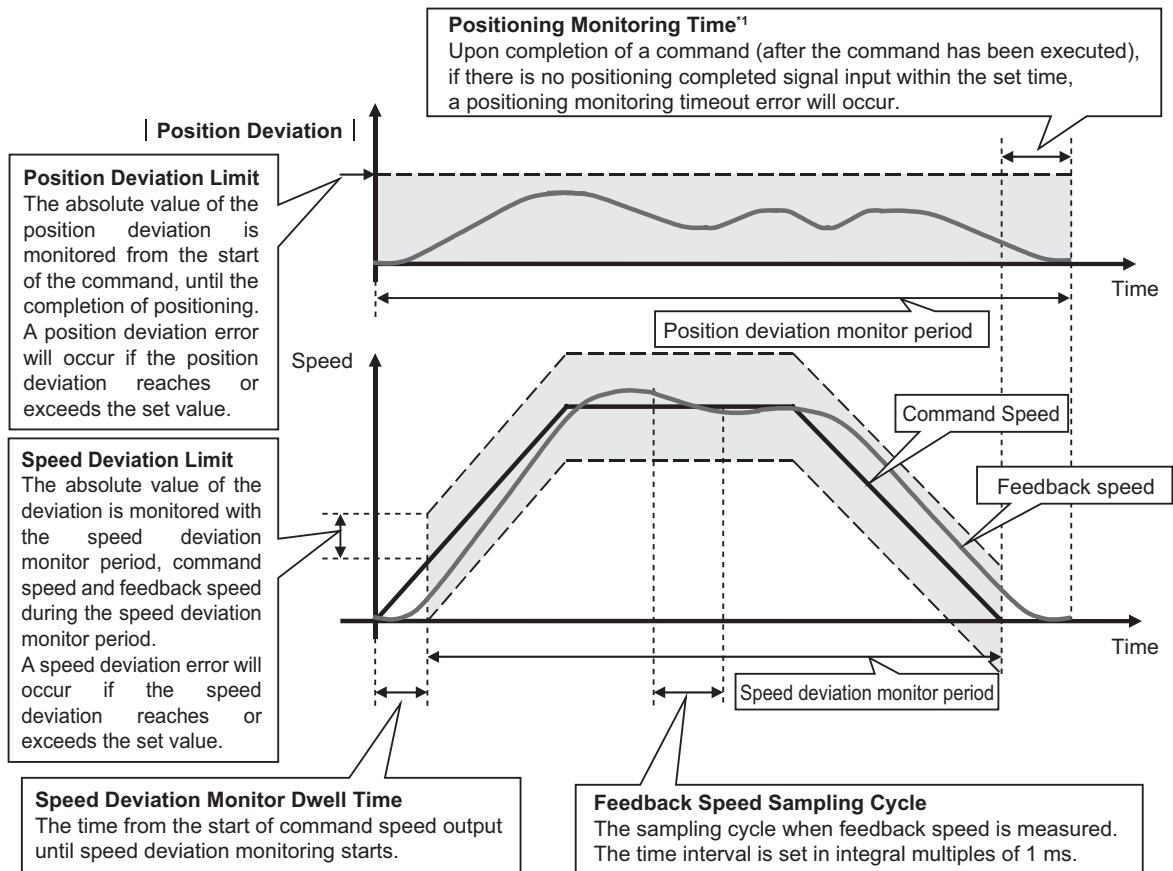

*1. For details on the positioning monitor time, refer to *Positioning Monitoring Time* on page 6-35.



Reference

- With the error monitor function, monitoring starts at the start of operation of the axis whose monitoring is currently enabled (i.e., the Axis Busy Flag is ON), and ends upon completion of operation (i.e., when the Axis Busy Flag turns OFF).
- For linear interpolation or circular interpolation in memory operation, the error monitor function remains active on all configuration axes for which monitoring is enabled in the same task, until the series of operations are completed (until the Memory Operation Busy Flag turns OFF).
- If you have selected Automatic for the end pattern for memory operation during speed deviation monitoring, deviation monitoring continues to the next sequence if the positioning completed input monitoring is disabled. If the positioning completed input monitoring is enabled, speed deviation monitoring will start when the next sequence starts after the speed deviation monitor dwell time expires.

Speed Deviation Monitor Valid

Set whether to monitor the speed deviation between the command speed and feedback speed. If the speed deviation exceeds the value set for the Speed Deviation Limit Value parameter, a speed deviation error occurs.

Position Deviation Monitor Valid

Set whether to monitor the position deviation between the command position and feedback position. Position deviation is monitored based on the absolute coordinates of the command position and feedback position.

Position deviation is monitored after the command starts until positioning is completed.

If the position deviation exceeds the value set for the Position Deviation Limit Value parameter, a position deviation error occurs.

Feedback Speed Sampling Cycle

Set the sampling cycle for measuring the feedback speed.

Speed Deviation Monitor Dwell Time

Set the time from the start of the command speed output until the speed deviation monitor starts.

Speed Deviation Limit Value

Set the speed deviation to monitor as an amount of movement per speed sampling time.

Example:

To monitor a deviation of 10,000 command units/s at a feedback speed sampling cycle of 5 ms, the speed deviation limit is calculated as follows:

$$\text{Speed deviation limit} = \text{Monitor speed (command units/s)} \times \text{Feedback speed sampling cycle (s)}$$

Therefore, set 50 as the speed deviation limit value.

Position Deviation Limit Value

Set the position deviation amount you want to monitor.

Positioning Completed Width Setting

Set the positioning completed width.

The setting of the Positioning Completed Width parameter is continuously updated.

Parameter name	Function	Setting range	Unit	Default value
Positioning Completed Width	Set the positioning completed width.	0 to 2,147,483,647	Command units	10

If you set the Positioning Monitoring Time axis parameter to 0, arrival will not be monitored for the Servo Drive feedback position regardless of the setting of this parameter. Refer to 10-6 *Positioning Completion* for details.

Synchronous Data Link Setting

Set the items that are necessary to use the Synchronous Data Link function.

For the Synchronous Group Stop Selection setting, the Synchronous Data Link function settings are updated when the power supply is turned ON, the PCU is restarted, or the PCU is set up for the Synchronous Group Stop Selection setting. For other setting, they are continuously updated.

Synchronous Group Stop Selection

The Synchronous Data Link Memory Area is allocated to words 1200 to 1295 in the CPU I/O Area. Data can be exchanged between the allocated memory areas of PCUs based on the CPU and PCU settings.

The Synchronous Group Stop Selection setting corresponds to bits 00 to 14 of word 1200 in the Synchronous Data Link Memory Area and is used to select whether or not to stop the ongoing function when each bit turns ON.

Parameter name	Bit	Function	Setting range	Default value
Synchronous Group Stop Selection	00	Select whether or not to stop the function when bit 00 of word 1200 in the Synchronous Data Link Memory Area turns ON. 0: Do not stop when bit 00 turns ON. 1: Stop when bit 00 turns ON.	0 to 1	0
	01	Select whether or not to stop the function when bit 01 of word 1200 in the Synchronous Data Link Memory Area turns ON. 0: Do not stop when bit 01 turns ON. 1: Stop when bit 01 turns ON.	0 to 1	0
	02	Select whether or not to stop the function when bit 02 of word 1200 in the Synchronous Data Link Memory Area turns ON. 0: Do not stop when bit 02 turns ON. 1: Stop when bit 02 turns ON.	0 to 1	0
	03	Select whether or not to stop the function when bit 03 of word 1200 in the Synchronous Data Link Memory Area turns ON. 0: Do not stop when bit 03 turns ON. 1: Stop when bit 03 turns ON.	0 to 1	0
	04	Select whether or not to stop the function when bit 04 of word 1200 in the Synchronous Data Link Memory Area turns ON. 0: Do not stop when bit 04 turns ON. 1: Stop when bit 04 turns ON.	0 to 1	0
	05	Select whether or not to stop the function when bit 05 of word 1200 in the Synchronous Data Link Memory Area turns ON. 0: Do not stop when bit 05 turns ON. 1: Stop when bit 05 turns ON.	0 to 1	0

6-4 Axis Parameters

Parameter name	Bit	Function	Setting range	Default value
Synchronous Group Stop Selection	06	Select whether or not to stop the function when bit 06 of word 1200 in the Synchronous Data Link Memory Area turns ON. 0: Do not stop when bit 06 turns ON. 1: Stop when bit 06 turns ON.	0 to 1	0
	07	Select whether or not to stop the function when bit 07 of word 1200 in the Synchronous Data Link Memory Area turns ON. 0: Do not stop when bit 07 turns ON. 1: Stop when bit 07 turns ON.	0 to 1	0
	08	Select whether or not to stop the function when bit 08 of word 1200 in the Synchronous Data Link Memory Area turns ON. 0: Do not stop when bit 08 turns ON. 1: Stop when bit 08 turns ON.	0 to 1	0
	09	Select whether or not to stop the function when bit 09 of word 1200 in the Synchronous Data Link Memory Area turns ON. 0: Do not stop when bit 09 turns ON. 1: Stop when bit 09 turns ON.	0 to 1	0
	10	Select whether or not to stop the function when bit 10 of word 1200 in the Synchronous Data Link Memory Area turns ON. 0: Do not stop when bit 10 turns ON. 1: Stop when bit 10 turns ON.	0 to 1	0
	11	Select whether or not to stop the function when bit 11 of word 1200 in the Synchronous Data Link Memory Area turns ON. 0: Do not stop when bit 11 turns ON. 1: Stop when bit 11 turns ON.	0 to 1	0
	12	Select whether or not to stop the function when bit 12 of word 1200 in the Synchronous Data Link Memory Area turns ON. 0: Do not stop when bit 12 turns ON. 1: Stop when bit 12 turns ON.	0 to 1	0
	13	Select whether or not to stop the function when bit 13 of word 1200 in the Synchronous Data Link Memory Area turns ON. 0: Do not stop when bit 13 turns ON. 1: Stop when bit 13 turns ON.	0 to 1	0
	14	Select whether or not to stop the function when bit 14 of word 1200 in the Synchronous Data Link Memory Area turns ON. 0: Do not stop when bit 14 turns ON. 1: Stop when bit 14 turns ON.	0 to 1	0
	15	–	–	–

Synchronous Feeding Position Function Selection

You can select the master axis data and the master axis number for the Synchronous Feeding Position command.

The Synchronous Feeding Position Function Selection settings are continuously updated and applied when the Synchronous Feeding Position command is executed.

You can also specify a virtual axis number as the master axis number for the Synchronous Feeding Position command.

Parameter name	Function	Setting range	Unit	Default value
Synchronous Feeding Position Function Selection	Select the master axis for the Synchronous Feeding Position command. 0: Do not select. 3: Electric Shaft (The feedback present position of the Servo Drive axis in the same unit is used as the master axis.) 4: Electric Shaft (The command present position of the Servo Drive axis in the same unit is used as the master axis.)	0, 3 to 4	—	0
Synchronous Feeding Position Master Axis No.	Specify the Servo Drive axis number in the PCU.	0 to 16	—	0

Synchronous Feeding Velocity Function Selection

Select whether to use the master axis as the target of the Synchronous Feeding Velocity command and specify where in the Synchronous Data Link Memory Area the data to be output as the command speed is stored.

The Synchronous Feeding Velocity Function Selection settings are continuously updated and applied when the Synchronous Feeding Velocity command is executed.

Parameter name	Function	Setting range	Unit	Default value
Synchronous Feeding Velocity Function Selection	Select whether to use the master axis as the target of the Synchronous Feeding Velocity command. 0: Do not select. 1: Use the master axis as the target of Synchronous Data Link output.	0 to 1	—	0
Synchronous Feeding Velocity Command Data Offset	Specify where the command data is stored as the relative position (number of words) to the first word of the Synchronous Data Link data to be output.	0 to Output Size Upper Limit - 2	—	0

Synchronous Feeding Torque Function Selection

Select whether to use the master axis as the target of the Synchronous Feeding Torque command and specify where in the Synchronous Data Link Memory Area the data to be output as the command torque is stored.

The Synchronous Feeding Torque Function Selection settings are continuously updated and applied when the Synchronous Feeding Torque command is executed.

Parameter name	Function	Setting range	Unit	Default value
Synchronous Feeding Torque Function Selection	Select whether to use the master axis as the target of the Synchronous Feeding Torque command. 0: Do not select. 1: Use the master axis as the target of Synchronous Data Link output.	0 to 1	–	0
Synchronous Feeding Torque Command Data Offset	Specify where the command data is stored as the relative position (number of words) to the first word of the Synchronous Data Link data to be output.	0 to Output Size Upper Limit - 2	–	0

Synchronous Feeding Torque Option Selection

Select how the Synchronous Feeding Torque options work and specify where in the Synchronous Data Link Memory Area the data to be output as the torque data is stored.

The Synchronous Feeding Torque Option Selection settings are continuously updated and applied when the Synchronous Feeding Position or Synchronous Feeding Velocity command executed.

Parameter name	Function	Setting range	Unit	Default value
Synchronous Feeding Torque Option Selection	Select the torque option function. 0: Do not use option 1; do not use option 2. 1: Use option 1 as torque feedforward data; use option 2 as torque limit data (both directions). 2: Use option 1 as torque feedforward data; do not use option 2. 3: Do not use option 1; use option 2 as torque limit data (both directions). 4: Use option 1 as positive torque limit data; use option 2 as negative torque limit data.	0 to 4	–	0
Synchronous Feeding Torque Option Command Data Offset	Specify where the command data is stored as the relative position (number of words) to the first word of the Synchronous Data Link data to be output.	0 to Output Size Upper Limit - 2	–	0



Reference

The Synchronous Feeding Torque Option Command Data Offset settings are used when the Synchronous Feeding Position or Synchronous Feeding Velocity command is executed. They are not used, however, when the Synchronous Feeding Torque command is executed.

Synchronous Feeding Velocity Limitation Option

Select whether or not to use the Synchronous Feeding Velocity Limitation Option function and specify where in the Synchronous Data Link Memory Area the data to be output as the velocity limitation value is stored.

The Synchronous Feeding Velocity Limitation Option settings are continuously updated and applied when the Synchronous Feeding Torque command is executed.

The Synchronous Feeding Velocity Limitation Option settings are used when the Synchronous Feeding Torque command is executed.

Parameter name	Function	Setting range	Unit	Default value
Synchronous Feeding Velocity Limitation Selection	Select whether or not to use the optional Synchronous Feeding Velocity Limitation function. 0: Do not use the Synchronous Feeding Velocity Limitation function. 1: Use the Synchronous Feeding Velocity Limitation function.	0 to 1	–	0
Synchronous Feeding Velocity Limitation Value Offset	Specify where the command data is stored as the relative position (number of words) to the first word of the Synchronous Data Link data to be output.	0 to Output Size Upper Limit - 2	–	0



Reference

The Synchronous Feeding Velocity Limitation Option settings are used when the Synchronous Feeding Torque command is executed.

They are not used, however, when the Synchronous Feeding Position or Synchronous Feeding Velocity command is executed.

Auxiliary Axis Option Setting

The auxiliary axis is used to compensate for the slave axis position value specified with the Electric Shaft function.

Select whether to use the slave axis as the target of the Synchronous Feeding Position command and specify where in the Synchronous Data Link Memory Area the data to be output as the auxiliary position value is stored.

The Auxiliary Axis Option settings are continuously updated and applied when the Synchronous Feeding Position command is executed.

Parameter name	Function	Setting range	Unit	Default value
Synchronous Feeding Auxiliary Axis Selection	Select the auxiliary axis for the Synchronous Feeding Position command. 0: Do not use the use the slave axis. 1. Use the auxiliary axis as the target of Synchronous Data Link output.	0 to 1	–	0
Synchronous Feeding Auxiliary Axis Command Data Offset	Specify where the command data is stored as the relative position (number of words) to the first word of the Synchronous Data Link data to be output.	0 to Output Size Upper Limit - 2	–	0



Reference

The Synchronous Feeding Auxiliary Axis Command Data Offset settings are used when the Synchronous Feeding Position command is executed.

They are not used, however, when the Synchronous Feeding Velocity or Synchronous Feeding Torque command is executed.

Synchronous Feeding Position Master Axis Multiplier

Set the multiplier used to determine the slave axis position value with respect to the master axis position value achieved with the Synchronous Feeding Position command.

The Synchronous Feeding Position Master Axis Multiplier settings are continuously updated and applied when the Synchronous Feeding Position command is executed.

Parameter name	Function	Setting range	Unit	Default value
Synchronous Feeding Position Master Axis Multiplier Numerator	Set the numerator of the multiplier used to determine the slave axis position value with respect to that of the master axis.	-10,000 to 10,000	–	0
Synchronous Feeding Position Master Axis Multiplier Denominator	Set the denominator of the multiplier used to determine the slave axis position value with master axis position value.* ¹	0 to 10,000	–	0

*1. Setting this to 0 means a multiplication factor of 1.

Synchronous Feeding Position Filter Constant

Use this parameter to filter the output of the slave axis by using the filter mechanism that helps suppress its rapid braking due to a sudden change in the movement of the master or auxiliary axis.

The Filter Constant setting is continuously updated and applied when the Synchronous Feeding Position command is executed.

Parameter name	Function	Setting range	Unit	Default value
Synchronous Feeding Position Filter Constant	Set the output filter value. 0: Function disabled 1 to 32,767: Output filter setting. The output filter value is a tenth of this setting.	0 to 32,767	–	0

6-5 Memory Operation Parameters

To execute memory operation with the PCU, you must determine the applicable tasks first. Use memory operation parameters to set the tasks.

Tasks

A task is an axis configuration that is used to execute memory operation.

Up to two tasks can be set for the CJ1W-NC281 and up to four tasks can be set for the CJ1W-NC481/881/F81/482/882/F82.

Up to four axes can be assigned to one task. You cannot set more than four axes.

With the PCU, you can set up to four tasks. A task refers to an axis configuration based what to execute in memory operation. If you allocate 1 axis to 1 task to set 4 tasks, the 4 axes operate independently. If you allocate 4 axes to 1 task, you can perform linear interpolation of 4 axes.

The maximum number of axes of the PCU can be used. This corresponds to axes 1 to 16 for a CJ1W-NCF81 PCU.

You cannot allocate the same axis to more than one task.

For information on the configuration axis allocations, refer to *Configuration Axes for Memory Operation* on page 8-2.

Example 1: 4 tasks, 4 axes used

Task 1 Axis 1	Task 2 Axis 2	Task 3 Axis 3	Task 4 Axis 4
------------------	------------------	------------------	------------------

Example 2: 2 tasks, 3 axes used

Task 1 axes 1 and 2	Task 2 Axis 3	Task 1 axes 2 and 3	Task 2 axes 2 and 4
------------------------	------------------	------------------------------------	------------------------------------

Example 3: 2 tasks, 5 axes used

Task 1 axes 1, 2 and 3	Task 2 axes 4 and 5	Task 1 axes 1, 2 and 3	Task 2 axes 1, 4 and 5
---------------------------	------------------------	---------------------------------------	---------------------------------------

Memory Operation Parameter Table

There are four sets of memory operation parameters for tasks 1 to 4. Set the parameters according to the number of tasks that you will use.

The following description is for 1 task.

General name	Parameter name	Reference page	Update timing
Configuration Axis	Configuration Axis	page 6-72	At PCU startup, PCU restart, or PCU setup
Teaching Setting	Teaching Target	page 6-73	Continuously
Interpolation Axis Stop Method	Interpolation Axis Stop Method	page 6-73	At PCU startup, PCU restart, or PCU setup
Deviation between Axes Monitor Settings	Deviation between Axes Monitor Enable	page 6-74	Continuously
	Deviation between Axes Limit Value		
	Deviation between Axes Monitor Target Axis		

Configuration Axes

Select the configuration axes for the task.

The setting of the Configuration Axes parameter is updated when the power supply is turned ON, the PCU is restarted, or the PCU is set up.

Parameter name	Function	Setting range	Unit	Default value
Configuration Axes ^{*1}	Select the configuration axes for the task. Bit 00: Turn ON to use axis 1. Otherwise turn OFF. Bit 01: Turn ON to use axis 2. Otherwise turn OFF. Bit 02: Turn ON to use axis 3. Otherwise turn OFF. Bit 03: Turn ON to use axis 4. Otherwise turn OFF. Bit 04: Turn ON to use axis 5. Otherwise turn OFF. Bit 05: Turn ON to use axis 6. Otherwise turn OFF. Bit 06: Turn ON to use axis 7. Otherwise turn OFF. Bit 07: Turn ON to use axis 8. Otherwise turn OFF. Bit 08: Turn ON to use axis 9. Otherwise turn OFF. Bit 09: Turn ON to use axis 10. Otherwise turn OFF. Bit 10: Turn ON to use axis 11. Otherwise turn OFF. Bit 11: Turn ON to use axis 12. Otherwise turn OFF. Bit 12: Turn ON to use axis 13. Otherwise turn OFF. Bit 13: Turn ON to use axis 14. Otherwise turn OFF. Bit 14: Turn ON to use axis 15. Otherwise turn OFF. Bit 15: Turn ON to use axis 16. Otherwise turn OFF.	0000 to F000 hex	–	0

*1. Up to four axes can be selected for one task. An error will occur if more than four axes are selected.



Precautions for Correct Use

- ♦ You cannot set an axis that is already in use for other task.
- ♦ The configuration axes are set only when using an OMNUC G5-series Servo Drive.

Teaching Setting

Select the target position data for task teaching.

The teaching setting is continuously updated.

Parameter name	Function	Setting range	Unit	Default value
Teaching Target	Select the target position data for teaching. 0: Command position, 1: Feedback position	0 to 1	—	0

Interpolation Axis Stop Method

Set the stop method that will apply to other axes when the servo is unlocked, the deviation counter is reset, or a deceleration stop is executed for one interpolation axis during memory operation.

The setting of the Interpolation Axis Stop Method parameter is updated when the power supply is turned ON, the PCU is restarted, or the PCU is set up.

Parameter name	Function	Setting range	Unit	Default value
Interpolation Axis Stop Method	0: Immediate stop (deviation pulse stop) 1: Deceleration stop ^{*1} 4: Stop reference output (free-run stop) 5: Interpolation path deceleration stop	0 to 5	—	0

*1. The *Single Axis Deceleration Time at Interpolation* on page 6-39 axis parameter is used for deceleration.

Deviation between Axes Monitor Settings

Set the function to monitor feedback positions between axes in linear interpolation.

For details, refer to *10-1 Feedback Position Monitoring* on page 10-1.

The deviation between axes monitor setting is continuously updated.

Parameter name	Function	Setting range	Unit	Default value
Deviation between Axes Monitor Enable	Select whether to monitor the feedback counter between axes. 0: Do not monitor, 1: Monitor	0 to 1	–	0
Deviation between Axes Limit Value	Set the allowable deviation in the feedback counter between axes.	0 to 65,535	Command units	0
Deviation between Axes Monitor Target Axis ^{*1}	Select the configuration axes to monitor. Bit 00: Turn ON to monitor configuration axis 1. Otherwise turn OFF. Bit 01: Turn ON to monitor configuration axis 2. Otherwise turn OFF. Bit 02: Turn ON to monitor configuration axis 3. Otherwise turn OFF. Bit 03: Turn ON to monitor configuration axis 4. Otherwise turn OFF.	0000 to 000F hex	–	0

*1. Do not specify axis numbers directly. Specify the configuration axis numbers.

Deviation between Axes Monitor Enable

Select whether to use the position deviation monitor between axes function for linear interpolation.

Deviation between Axes Limit Value

Set the position deviation between axes to monitor for linear interpolation.

Deviation between Axes Monitor Target Axis

Set the axes to monitor for linear interpolation.

Select an axis that has been registered as a configuration axis. Select at least two axes.

The numbers of axes are treated in the ascending order of configuration axes 1 to 4 (maximum) selected in the Configuration Axis parameter in memory operation. For details, refer to *Configuration Axes* on page 6-72.



Precautions for Correct Use

- ♦ An error will occur if the specified axes are not physical axes or if only one axis is selected.

6-6 Operation Memory Areas

The operation memory areas are where the output bits used to execute operation commands for the PCU and the input bits used for indicating the PCU status are allocated.

The operation memory areas include the PCU Control Memory Area, Manual Operation Command Memory Area, Direct Operation Command Memory Area, Axis Status Memory Area, Memory Operation Command Memory Area, Memory Operation Status Memory Area, Expanded Monitor Memory Area, Remote I/O Communications Status Memory Area, Remote I/O Output Memory Area, and Remote I/O Input Memory Area.

The following table lists the memory areas that are used for each type of operation.

Operation Memory Area	Positioning function ^{*1}				Remote I/O master function ^{*2}
	Manual operation	Origin searches	Direct operation	Memory operation	
PCU Control Output Memory Area	○	○	○	○	○
PCU Control Memory Input Area	○	○	○	○	○
Manual Operation Command Memory Area	○	○	○	○	–
Direct Operation Command Memory Area	–	–	○	–	○ ^{*3}
Axis Status Memory Area	○	○	○	○	○ ^{*4}
Memory Operation Command Memory Area	–	–	–	○	–
Memory Operation Status Memory Area	–	–	–	○	–
Expanded Monitor Memory Area	○ ^{*5}	○ ^{*5}	○ ^{*5}	○ ^{*5}	○ ^{*4}
Remote I/O Communications Status Memory Area	–	–	–	–	○ ^{*6}
Remote I/O Output Memory Area	–	–	–	–	○ ^{*6}
Remote I/O Input Memory Area	–	–	–	–	○ ^{*6}

*1. This area is used when connecting an OMNUC G5-series Servo Drives with EtherCAT for position control.

*2. The remote I/O master function can be used with a PCU with unit version 1.1 or later.

*3. Used as output memory area for the remote I/O slaves with node addresses 1 to 16.

*4. Used as input memory area for the remote I/O slaves with node addresses 1 to 16.

*5. Used when using expanded monitor.

*6. Operation memory area for remote I/O slaves with node addresses 17 to 80.
This is applicable only when using CJ1W-NC482/882/F82 PCUs only.

Outline of Operation Memory Areas

There are two types of operation memory areas. One of the areas is allocated in the CPU Bus Unit Area of the CPU Unit. The other areas are set in the common parameters.

The operation memory areas are divided into output and input areas.

Command bits that are related to operation are allocated in the output areas. A command is sent to the PCU while a command bit is ON or when a command bit is turned ON. Command data is also set.

The input areas are allocated to flags and data for internal PCU status and external I/O status. Applicable data is input from the PCU.

For example, if the Four-axis PCU (CJ1W-NC481) is used, axes 1 and 2 are set as physical axes and the other two axes are set not to be used, words will be allocated only for two axes.

If you set axes 1 and 3 as physical axes with the remaining 2 axes set as unused axes, each memory area contains the words for 3 axes even though only 2 axes are set as physical axes.

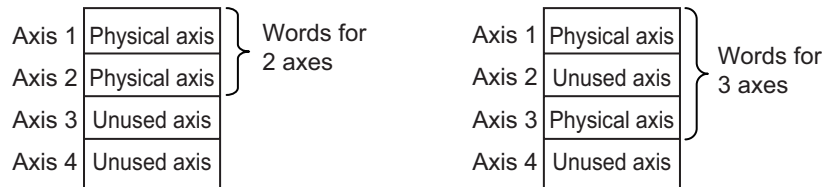

There is a remote I/O slave memory area that is used to control remote I/O when using a CJ1W-NC482/882/F82 PCU.

For details on how to allocate the memory area for remote I/O, refer to *Relation between Allocated Areas of Memory* on page 6-3.

Basic Usage of Operation Bits for Position Control

When connecting to an OMNUC G5-series Servo Drive with EtherCAT for position control, the operation memory areas of the PCU contain an output memory area that is used to start functions, and a corresponding input memory area.

The input flags indicate five types of status: command acknowledged flags, executing flags, command invalid flags, successful completion flags, and error flags.

Not all five types of status are available for all functions.

The following table shows the bits for basic functions.

Type	Bit type	Function	Bits related to data transfer	Bits related to manual operation and direct operation	Bits related to memory operation
Outputs	Command bits	The user turns ON a command bit to start an operation or function.	Write Data Bit Read Data Bit Save Data Bit etc.	Servo Lock Bit Jogging/Inching Bit Origin Search Bit Origin Return Bit Absolute Movement Bit Relative Movement Bit etc.	Memory Operation Start Bit Memory Operation Individual Start Bit Teaching Bit, etc.

6-6 Operation Memory Areas

Type	Bit type	Function	Bits related to data transfer	Bits related to manual operation and direct operation	Bits related to memory operation
Inputs	Command Acknowledged Flags	Command acknowledged flags shown when command bits that are turned ON and OFF in a ladder program have been acknowledged. For functions that are executed when a command bit is turned ON, use the command acknowledged flags to hold the status.	Write Data Acknowledged Flag Read Data Acknowledged Flag Save Data Acknowledged Flag, etc.	Servo Lock Acknowledged Flag Origin Search Acknowledged Flag Origin Return Acknowledged Flag, etc.	Memory Operation Acknowledged Flag M Code Reset Acknowledged Flag Teaching Acknowledged Flag, etc.
	Executing Flags	Executing flags indicate that the command function is currently being executed. They can be used as for interlocks if executing a different function during processing would cause an error.	Data Transfer Flag, etc.	Axis Busy Flag, etc.	Memory Operation Busy Flag, etc.
	Command Invalid Flags	Command invalid flags indicate that the executed command failed because it did not meet the conditions for starting the applicable function. Command invalid flags turn ON when an operation could not be started due to an error at the start of the command or because of the priority of the command.	Data Transfer Invalid Flag, etc.	Start Invalid Flag, etc.	Memory Operation Invalid Flag Teaching Invalid Flag, etc.
	Successful Completion Flags	Successful completion flags indicate that a process was completed successfully.	Data Transfer Completed Flag, etc.	Positioning Operation Completed Flag, etc.	Memory Operation Positioning Operation Completed Flag, etc.
	Error Flags	Error flags indicate that an error occurred when you started or executed the command function.	PCU Error Flag PCU Warning Flag, etc.	Axis Error Flag Axis Warning Flag, etc.	Memory Operation Error Flag Memory Operation Warning Flag, etc.

In addition to the above bits, the following command bits that use executing flags, command invalid flags, and successful completion flags are also provided.

Command bit name	Bit type	Status flag name
Error Reset Bit	Executing Flag	Resetting Error Flag
Axis Deceleration Stop Bit	Successful Completion Flag	Stop Executed Flag
Memory Operation Stop Bit	Successful Completion Flag	Memory Operation Stopped Flag
Deviation Counter Reset Bit	Command Invalid Flag	Deviation Counter Reset Invalid Flag

Basic Flow of Operation to Use Operation Bits for Position Control

The following chart shows the basic operation flow.

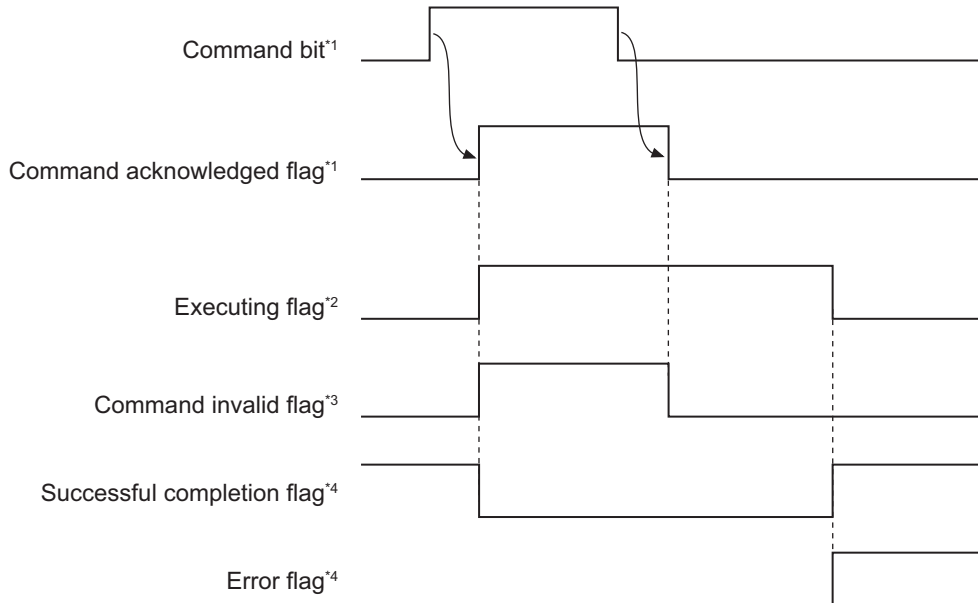

- *1. For a command that starts when the command bit is turned ON, you can turn OFF the command bit as soon as the command acknowledged flag turns ON.
- *2. For a function that takes time to process, the executing flag remains ON while processing is in progress.
- *3. If the execution conditions are not satisfied, the command invalid flag also remains ON while the command acknowledged flag is ON.
- *4. One of these flags turns ON depending on whether the command was successful or an error occurred.

PCU Control Memory Area

Bits and words for reading/writing data, resetting errors, error flags, error codes, and other items that are related to the PCU status are allocated in this area.

The PCU Control Memory Area is allocated in the CPU Bus Unit Area.

The first word that is allocated to the PCU in the CPU Bus Unit Area can be calculated from the unit number of the PCU using the following formula.

First word allocated to PCU in CPU Bus Unit Area, $n = \text{CIO } 1500 + 25 \times \text{unit number}$

PCU Control Output Memory Area

Words	Name	Bits	Bit name	Function
n	PCU Control Command Bits	0	Error Reset Bit	Turn ON this bit to reset errors that are common to overall PCU operation.
		1	Warning Reset Bit	Turn ON this bit to reset warnings that are common to overall PCU operation.
		2 to 11	Not used.	Do not use.
		12	Write Data Bit	Turn ON this bit to start writing data.
		13	Read Data Bit	Turn ON this bit to start reading data.
		14	Save Data Bit	Turn ON this bit to save data.
		15	PCU Setup Bit	Turn ON this bit to reset the PCU. The reset status is held as long as this bit remains ON.
n+1	Number of Data Transfer Words	0 to 15	–	Set the number of words to read or write.*1
n+2	CPU Unit Data Transfer Area	0 to 15	–	Set the area in the CPU Unit. 00B0 (hex): Core I/O Area (CIO Area) 00B1 (hex): Work Area (WR Area) 00B2 (hex): Holding Area (HR) 0082 (hex): DM Area (DM) 0050 to 0068 (hex): EM Area (EM)*2 0050 (hex): EM bank 0 0051 (hex): EM bank 1 : 0068 (hex): EM bank 24 00A0 to 00AF (hex): EM Area (EM)*3 00A0 (hex): EM bank 0 00A1 (hex): EM bank 1 : 00AF (hex): EM bank F

Words	Name	Bits	Bit name	Function
n+3	CPU Unit Data Transfer Beginning Word	0 to 15	—	Set the beginning word in the CPU Unit. Specify the first word in the I/O memory of the CPU Unit that contains the data to transfer. This word will be in the data transfer area that was set. Example: To specify D00100 CPU Unit Data Transfer Area (n+2): 0082 (hex) CPU Unit Data Transfer Beginning Word (n+3): 0064 (hex)
n+4	PCU Data Transfer Area ^{*4}	0 to 15	—	Set the area in the PCU. Set the value in hexadecimal.
n+5	PCU Data Transfer Beginning Word ^{*3}	0 to 15	—	Set the address of beginning word 1 in the PCU. ^{*5} Set the value in hexadecimal.
n+6	PCU Data Transfer Beginning Word 2 ^{*3}	0 to 15	—	Set the address of beginning word 2 in the PCU. ^{*6} Set the value in hexadecimal.
n+7	Origin Proximity Input Internal Memory Area	0 to 15	—	If the Origin Proximity Input Signal Selection is set to 0 (Use General-purpose Output Bit as the origin proximity input), General-purpose Output Bits 00 to 15 will correspond to the origin proximity inputs for axes 1 to 16.

*1. If the Servo Drive Parameter Area is selected for the PCU Area, these bits function as the data size.

*2. CJ2 CPU Units. The number of banks that can be used depends on the model of the CPU Unit.

*3. CJ1 CPU Units. The number of banks that can be used depends on the model of the CPU Unit.

*4. For details on areas and addresses, refer to *Data Addresses* on page 9-4.

*5. If the Servo Drive Parameter Area is selected for the PCU Area, the setting of this parameter functions as an index.

*6. If the Servo Drive Parameter Area is selected for the PCU Area, the setting of this parameter functions as a subindex.

PCU Control Memory Input Area

Words	Name	Bit	Bit name	Function
n+11	PCU Control Command Acknowledged Flags	0	Error Reset Acknowledged Flag	This flag turns ON to acknowledge the Error Reset Bit.
		1	Warning Reset Acknowledged Flag	This flag turns ON to acknowledge the Warning Reset Bit.
		2 to 11	Not used.	Do not use.
		12	Write Data Acknowledged Flag	This flag turns ON to acknowledge the Write Data Bit.
		13	Read Data Acknowledged Flag	This flag turns ON to acknowledge the Write Read Bit.
		14	Save Data Acknowledged Flag	This flag turns ON to acknowledge the Save Data Bit.
		15	PCU Ready Flag	This flag turns ON when the PCU is ready.

6-6 Operation Memory Areas

Words	Name	Bit	Bit name	Function
n+12	PCU Control Status	0	Data Transfer Flag	This flag remains ON while the data transfer is in progress.
		1	Data Transfer Invalid Flag	This flag turns ON when the data transfer fails.
		2	Data Transfer Completed Flag	This flag turns ON when a data write, data read, or data save operation is completed successfully.
		3	Save Data Request Flag	This flag turns ON whenever data will be lost if you turn OFF the power supply without saving the data.
		4	Resetting Error Flag	This flag remains ON while an error reset is in progress.
		5 to 7	Not used.	Do not use.
		8	Synchronous Operating ^{*1}	This flag remains ON while the PCU is operating in synchronous mode.
		9	EtherCAT Detection Processing Flag	This flag is ON while connections for EtherCAT communications are being processed.
		10	Support Software-controlled Data Transfer Mode Flag	This flag is ON when the PCU is in Support Software-controlled Data Transfer Mode.
		11	Support Software-controlled Operation Mode Flag	This flag is ON when the PCU is in Support Software-controlled Operation Mode.
		12 to 15	Not used.	Do not use.
n+13	PCU Error Status	0	Restore Error Flag	This flag turns ON when there is an inconsistency between internal PCU settings and the system environment. This flag turns ON when an error is detected when checking the parameters in the network configuration information.
		1	Synchronous Data Receive Error ^{*1}	This flag turns ON when two or more attempts to deliver synchronous data from the CPU fail or when a synchronization time monitoring timeout error occurs.
		2	Synchronous Data Receive Warning ^{*1}	This flag turns ON when one or more attempts to deliver synchronous data from the CPU fails (for the warning purpose).
		3 to 4	Not used.	Do not use this bit.
		5	ABS Encoder Backup Data Error ^{*1}	This flag turns ON when absolute encoder backup data is corrupted in nonvolatile memory or when data is corrupted due to power OFF while saving data.
		6	Not used.	Do not use.
		7	Hardware Failure Flag	This flag turns ON when a hardware failure occurs.
		8	Saved Data Error Flag	This flag turns ON when data is corrupted in nonvolatile memory or when data is corrupted when the power is turned OFF while saving data.

Words	Name	Bit	Bit name	Function
n+13 (continued)	PCU Error Status	9	PLC System Error Flag	This flag turns ON when an error is input from outside the system.
		10	Not used.	Do not use.
		11	PCU Warning Flag	This flag turns ON upon detection of a common warning-level error within the PCU.
		12	PCU Error Flag	This flag turns ON when a common error within in the PCU is detected.
		13	Overall Axis Error Flag	This flag turns ON when an axis error occurs.
		14	Overall Memory Operation Error Flag	This flag turns ON when a memory operation error occurs.
		15	Overall Error Flag	This flag turns ON when an error occurs in the PCU.
n+14	PCU Error Code	0 to 15	–	This word stores then PCU error code.
n+15	Memory Operation Auxiliary Memory Area	0 to 15	–	Bits 00 to 15 are input bits that can be specified inside the PCU.
n+16	Not used.	0 to 15	Do not use.	
n+17	Not used.	0 to 15	Do not use.	
n+18	Communications Status	0 to 11	Not used.	Do not use.
		12	Reserved by system.	This bit is used by the PCU system. Do not use.
		13	Link Status Flag	This flag is ON while a link is established with the slaves.
		14	All Slave Process Data Communications Flag	This flag is ON when process data communications are in progress for all slaves in the network.
		15	Not used.	Do not use.
n+19	Communications Error Flags	0	Network Configuration Verification Error	This flag turns ON when the slave information registered in the network configuration information does not agree with the slaves actually in the network.
		1	Network Configuration Error Flag	This flag turns ON when an unsupported network configuration is detected. It turns ON when the maximum number of slaves is exceeded or when an incorrect topology is detected.
		2	Process Data Communications Error Flag	This flag is ON when any of the following errors occurs in process data communications. <ul style="list-style-type: none"> ♦ A WKC error was detected. ♦ A watchdog timer error occurred in a slave. ♦ A topology change was detected during process data communications.
		3	Process Data Reception Timeout Flag	This flag turns ON if the number of times the EtherCAT frame could not be received during the communications cycle exceeds the timeout detection count.

6-6 Operation Memory Areas

6

Setting Data

Words	Name	Bit	Bit name	Function
n+19 (continued)	Communications Error Flags	4	Communications Parameter Setting Error Flag	This flag turns ON when an error is detected when checking the parameters in the network configuration information.
		5	Frame Send Timing Error Flag	This flag turns ON when a frame cannot be sent normally.
		6 to 8	Not used.	Do not use.
		9	Link OFF Error	This flag turns ON when an error occurs while establishing a link with a slave.
		10	Slave Node Address Duplicated Flag	This flag turns ON when the same node address is used by more than one slave in the network.
		11	Slave Initialization Error Flag	This flag turns ON when an error occurs during slave initialization processing.
		12	Slave AL Status Error Flag	This flag turns ON when an AL status error occurs in one or more slaves in the network.
		13	Not used.	Do not use.
		14	Non-fatal Process Data Communications Error Flag	This flag turns ON when a non-fatal error occurs in process data communications.
		15	Fatal Process Data Communications Error Flag	This flag turns ON when a fatal error occurs in process data communications.
n+20	Registered Slave Table	0	Node 1 Registered Flag	These flags turn ON when the corresponding nodes exist in the network configuration information. *2
		1	Node 2 Registered Flag	
		2	Node 3 Registered Flag	
		3	Node 4 Registered Flag	
		4	Node 5 Registered Flag	
		5	Node 6 Registered Flag	
		6	Node 7 Registered Flag	
		7	Node 8 Registered Flag	
		8	Node 9 Registered Flag	
		9	Node 10 Registered Flag	
		10	Node 11 Registered Flag	
		11	Node 12 Registered Flag	

Words	Name	Bit	Bit name	Function
n+20 (continued)	Registered Slave Table	12	Node 13 Registered Flag	These flags turn ON when the corresponding nodes exist in the network configuration information.*2
		13	Node 14 Registered Flag	
		14	Node 15 Registered Flag	
		15	Node 16 Registered Flag	
n+21	Network Participation Table	0	Node 1 Network Participation Flag	These flags turn ON when the corresponding nodes are detected in the network.*2
		1	Node 2 Network Participation Flag	
		2	Node 3 Network Participation Flag	
		3	Node 4 Network Participation Flag	
		4	Node 5 Network Participation Flag	
		5	Node 6 Network Participation Flag	
		6	Node 7 Network Participation Flag	
		7	Node 8 Network Participation Flag	
		8	Node 9 Network Participation Flag	
		9	Node 10 Network Participation Flag	
		10	Node 11 Network Participation Flag	
		11	Node 12 Network Participation Flag	
		12	Node 13 Network Participation Flag	
		13	Node 14 Network Participation Flag	
		14	Node 15 Network Participation Flag	
		15	Node 16 Network Participation Flag	

6-6 Operation Memory Areas



Setting Data

Words	Name	Bit	Bit name	Function
n+22	Slave Message Communications Enabled Table	0	Node 1 Message Communications Enabled Flag	These flags turn ON when message communications are enabled for the corresponding nodes.*2
		1	Node 2 Message Communications Enabled Flag	
		2	Node 3 Message Communications Enabled Flag	
		3	Node 4 Message Communications Enabled Flag	
		4	Node 5 Message Communications Enabled Flag	
		5	Node 6 Message Communications Enabled Flag	
		6	Node 7 Message Communications Enabled Flag	
		7	Node 8 Message Communications Enabled Flag	
		8	Node 9 Message Communications Enabled Flag	
		9	Node 10 Message Communications Enabled Flag	
		10	Node 11 Message Communications Enabled Flag	
		11	Node 12 Message Communications Enabled Flag	
		12	Node 13 Message Communications Enabled Flag	
		13	Node 14 Message Communications Enabled Flag	
		14	Node 15 Message Communications Enabled Flag	
		15	Node 16 Message Communications Enabled Flag	

Words	Name	Bit	Bit name	Function
n+23	Normal Slave Table	0	Node 1 Normal Communications Flag	These flags turn ON when process data communications are being performed for the corresponding nodes.*2
		1	Node 2 Normal Communications Flag	
		2	Node 3 Normal Communications Flag	
		3	Node 4 Normal Communications Flag	
		4	Node 5 Normal Communications Flag	
		5	Node 6 Normal Communications Flag	
		6	Node 7 Normal Communications Flag	
		7	Node 8 Normal Communications Flag	
		8	Node 9 Normal Communications Flag	
		9	Node 10 Normal Communications Flag	
		10	Node 11 Normal Communications Flag	
		11	Node 12 Normal Communications Flag	
		12	Node 13 Normal Communications Flag	
		13	Node 14 Normal Communications Flag	
		14	Node 15 Normal Communications Flag	
		15	Node 16 Normal Communications Flag	

6-6 Operation Memory Areas



Words	Name	Bit	Bit name	Function
n+24	Error Slave Table	0	Node 1 Communications Error Flag	<p>These flags turn ON when any of the following communications errors occur in the corresponding nodes.*²</p> <ul style="list-style-type: none"> ◆ Slave Initialization Error Flag ◆ Slave Node Address Duplicated Flag ◆ Slave AL Status Error Flag ◆ Network Configuration Verification Error Flag ◆ Process Data Communications Error Flag
		1	Node 2 Communications Error Flag	
		2	Node 3 Communications Error Flag	
		3	Node 4 Communications Error Flag	
		4	Node 5 Communications Error Flag	
		5	Node 6 Communications Error Flag	
		6	Node 7 Communications Error Flag	
		7	Node 8 Communications Error Flag	
		8	Node 9 Communications Error Flag	
		9	Node 10 Communications Error Flag	
		10	Node 11 Communications Error Flag	
		11	Node 12 Communications Error Flag	
		12	Node 13 Communications Error Flag	
		13	Node 14 Communications Error Flag	

Words	Name	Bit	Bit name	Function
n+24 (continued)	Error Slave Table	14	Node 15 Communications Error Flag	These flags turn ON when any of the following communications errors occur in the corresponding nodes.*2 <ul style="list-style-type: none"> ◆ Slave Initialization Error Flag ◆ Slave Node Address Duplicated Flag ◆ Slave AL Status Error Flag ◆ Network Configuration Verification Error Flag ◆ Process Data Communications Error Flag
		15	Node 16 Communications Error Flag	

*1. Available with version 1.3 or later PCUs.

*2. Bits 02 to 07 are not used for a two-axis PCU, bits 04 to 07 are not used for a four-axis PCU, and bits 08 to 15 are not used for an eight-axis PCU.

Manual Operation Command Memory Area

For information on the setting method for the Manual Operation Command Memory Area, refer to *Manual Operation Command Memory Area Selection* on page 6-17.

The following table lists the memory allocations when you set the First Word of Manual Operation Command Memory Area parameter to word "A."



Precautions for Correct Use

The Manual Operation Command Memory Area is disabled when the PCU is connected to a device other than an OMNUC G5-series Servo Drive.

Words	Name	Bit	Bit name	Function
A	Axis 1 Manual Operation Command Memory Area	0	Servo Lock Bit	Turn ON this bit to lock the servo.
		1	Drive Alarm Reset Bit	Turn ON this bit to reset the Servo Drive alarm.
		2	Deviation Counter Reset Bit	Turn ON this bit to reset the deviation counter.
		3	Forward Torque Limit Bit	Use this bit to enable or disable the forward torque limit. ON: Enabled, OFF: Disabled
		4	Reverse Torque Limit Bit	Use this bit to enable or disable the reverse torque limit. ON: Enabled, OFF: Disabled
		5	Override Enable Bit	Specify whether to enable or disable an override. ON: Enabled, OFF: Disabled
		6	Jogging/Inching Speed Selection Bit	Select the jogging/inching speed. Turn OFF this bit to select speed 1 and turn ON this bit to select speed 2.
		7	Forward Jogging/Inching Bit	Turn ON this bit to perform jogging or inching in the forward direction.
		8	Reverse Jogging/Inching Bit	Turn ON this bit to perform jogging or inching in the reverse direction.
		9	Not used.	Do not use.
		10	Origin Search Bit	Turn ON this bit to start an origin search.
		11	Origin Return Bit	Turn ON this bit to start an origin return.
		12	Not used.	Do not use.
		13	Immediate Stop Bit	Turn ON this bit to start performing an immediate stop.
		14	Deceleration Stop Bit	Turn ON this bit to start performing a deceleration stop.*1
15	Servo Unlock Bit	Turn ON this bit to unlock the servo.		
A+1	Axis 1 Override	0 to 15	Set the override in hexadecimal. You can set any value from 1 to 50,000 (0001 to C350 hex), which correspond to 0.01% to 500.00%.	
A+2	Axis 2 Manual Operation Command Memory Area	0 to 15	Refer to the description for axis 1.	
A+3	Axis 2 Override	0 to 15		

Words	Name	Bit	Bit name	Function
A+4	Axis 3 Manual Operation Command Memory Area	0 to 15		Refer to the description for axis 1. These words are not used for a two-axis PCU.
A+5	Axis 3 Override	0 to 15		
A+6	Axis 4 Manual Operation Command Memory Area	0 to 15		
A+7	Axis 4 Override	0 to 15		
A+8	Axis 5 Manual Operation Command Memory Area	0 to 15		Refer to the description for axis 1. These words are not used for a two-axis or four-axis PCU.
A+9	Axis 5 Override	0 to 15		
A+10	Axis 6 Manual Operation Command Memory Area	0 to 15		
A+11	Axis 6 Override	0 to 15		
A+12	Axis 7 Manual Operation Command Memory Area	0 to 15		
A+13	Axis 7 Override	0 to 15		
A+14	Axis 8 Manual Operation Command Memory Area	0 to 15		
A+15	Axis 8 Override	0 to 15		
A+16	Axis 9 Manual Operation Command Memory Area	0 to 15		Refer to the description for axis 1. These words are not used for a two-axis, four-axis, or eight-axis PCU.
A+17	Axis 9 Override	0 to 15		
A+18	Axis 10 Manual Operation Command Memory Area	0 to 15		
A+19	Axis 10 Override	0 to 15		
A+20	Axis 11 Manual Operation Command Memory Area	0 to 15		
A+21	Axis 11 Override	0 to 15		
A+22	Axis 12 Manual Operation Command Memory Area	0 to 15		
A+23	Axis 12 Override	0 to 15		
A+24	Axis 13 Manual Operation Command Memory Area	0 to 15		
A+25	Axis 13 Override	0 to 15		
A+26	Axis 14 Manual Operation Command Memory Area	0 to 15		
A+27	Axis 14 Override	0 to 15		
A+28	Axis 15 Manual Operation Command Memory Area	0 to 15		
A+29	Axis 15 Override	0 to 15		
A+30	Axis 16 Manual Operation Command Memory Area	0 to 15		
A+31	Axis 16 Override	0 to 15		

*1. Turn OFF the Deceleration Stop Bit as soon as the Deceleration Stop Acknowledged Flag in the Axis Status Memory Area turns ON. If the Deceleration Stop Bit remains ON, the PCU may not acknowledge other commands for the axis.

Direct Operation Command Memory Area

For information on the setting method for the Direct Operation Command Memory Area, refer to *Direct Operation Command Memory Area Selection* on page 6-18.

The following table lists the memory allocations when you set the First Word of Direct Operation Command Memory Area parameter to word “B.”



Precautions for Correct Use

The Direct Operation Command Memory Area is used as the Remote I/O Output Memory Area when the PCU is connected to a device other than a OMNUC G5-series Servo Drive.

Words	Name	Bit	Bit name	Function
B	Axis 1 Direct Operation Command Memory Area	0	Absolute Movement Bit	Turn ON this bit to start an absolute positioning operation.
		1	Relative Movement Bit	Turn ON this bit to start a relative positioning operation.
		2	Speed Control Bit	Turn ON this bit to start speed control with position loop in the CSP mode.
		3 to 4	Not used.	Do not use.
		5	Interrupt Feeding Specification Bit	Enable or disable interrupt feeding when the Absolute Movement Bit, Relative Movement Bit, or Speed Control Bit turns ON. ON: Enabled, OFF: Disabled
		6	Interrupt Input Mask/ Present Position Latch Enable Bit	Use this bit to enable the interrupt input mask for interrupt feeding and enable the present position latch for the interrupt input. ON: Enabled, OFF: Disabled
		7	Present Position Preset Bit	Turn ON this bit to preset the present position.
		8	Synchronous Feeding Position Bit*1	While this bit is ON, the unit performs synchronous feeding position control.
		9	Synchronous Feeding Velocity Bit*1	While this bit is ON, the unit performs speed control and synchronous feeding velocity control without position loop in the CSV mode.
		10	Synchronous Feeding Torque Bit*1	While this bit is ON, the unit performs synchronous feeding torque control.
		11	Origin Position Latch Enable Bit*1	Enables the origin position latch. ON: Enabled, OFF: Disabled
		12 to 13	Not used.	Do not use.
		14	Origin Position Latch Clear Bit*1	Turn this bit ON to clear the Origin Position Latch Completed Flag.
15	Latch Completed Flag Clear Bit	Turn this bit ON to clear the Latch Completed Flag.		

Words	Name	Bit	Bit name	Function
B+1	Axis 1 Rotation Axis Direction	0 to 15		Specify the operating direction to be applied when you execute an absolute movement for an infinite axis. 0: Shortest route 1: Forward 2: Reverse 3: Not specified
B+2	Axis 1 Command Position (lower word)	0 to 15		Specify the position to be used in direct operation or present position preset. Set the value in command units in hexadecimal. Setting range: 8000 0000 to 7FFF FFFF hex (-2,147,483,648 to 2,147,483,647 command units)
B+3	Axis 1 Command Position (upper word)	0 to 15		
B+4	Axis 1 Command Speed (lower word)	0 to 15		Specify the target speed to be used in direct operation. Set the value in command units/s in hexadecimal. Setting Ranges: Position control: 1 to 7FFF FFFF hex (1 to 2,147,483,647 command units/s) Speed control: 8000 0000 to 7FFF FFFF hex (-2,147,483,648 to 2,147,483,647 command units/s)
B+5	Axis 1 Command Speed (upper word)	0 to 15		
B+6	Axis 1 Option Input 1 ^{*1}	0 to 15		Forward Torque Limit Data ^{*2} Specify the torque limit value when the forward torque limit is enabled. Setting range: 0 to 2710 hex (0 to 10000 [0.1%]) Set the value in 0.1%.
B+7	Axis 1 Option Input 2 ^{*1}	0 to 15		Reverse Torque Limit Data ^{*3} Specify the torque limit value when the reverse torque limit is enabled. Setting range: 0 to 2710 hex (0 to 10000 [0.1%]) Set the value in 0.1%.
B+8	Axis 1 Acceleration Time (lower word) ^{*4}	0 to 15		Specify the acceleration time. Set the value in ms in hexadecimal. Setting range: 0 to 3D090 hex (0 to 250,000 ms)
B+9	Axis 1 Acceleration Time (upper word) ^{*4}	0 to 15		
B+10	Axis 1 Deceleration Time (lower word) ^{*4}	0 to 15		Specify the deceleration time. Set the value in ms in hexadecimal. Setting range: 0 to 3D090 hex (0 to 250,000 ms)
B+11	Axis 1 Deceleration Time (upper word) ^{*4}	0 to 15		
B+12	Axis 2 Direct Operation Command Memory Area	0 to 15		
B+13	Axis 2 Rotation Axis Direction	0 to 15		Refer to the description for axis 1.
B+14	Axis 2 Command Position (lower word)	0 to 15		
B+15	Axis 2 Command Position (upper word)	0 to 15		
B+16	Axis 2 Command Speed (lower word)	0 to 15		
B+17	Axis 2 Command Speed (upper word)	0 to 15		
B+18	Axis 2 Option Input 1 ^{*1}	0 to 15		
B+19	Axis 2 Option Input 2 ^{*1}	0 to 15		
B+20	Axis 2 Acceleration Time (lower word) ^{*4}	0 to 15		

6-6 Operation Memory Areas



Words	Name	Bit	Bit name	Function
B+21	Axis 2 Acceleration Time (upper word) ^{*4}	0 to 15		Refer to the description for axis 1.
B+22	Axis 2 Deceleration Time (lower word) ^{*4}	0 to 15		
B+23	Axis 2 Deceleration Time (upper word) ^{*4}	0 to 15		
B+24	Axis 3 Direct Operation Command Memory Area	0 to 15		Refer to the description for axis 1. These words are not used for a two-axis PCU.
B+25	Axis 3 Rotation Axis Direction	0 to 15		
B+26	Axis 3 Command Position (lower word)	0 to 15		
B+27	Axis 3 Command Position (upper word)	0 to 15		
B+28	Axis 3 Command Speed (lower word)	0 to 15		
B+29	Axis 3 Command Speed (upper word)	0 to 15		
B+30	Axis 3 Option Input 1 ^{*1}	0 to 15		
B+31	Axis 3 Option Input 2 ^{*1}	0 to 15		
B+32	Axis 3 Acceleration Time (lower word) ^{*4}	0 to 15		
B+33	Axis 3 Acceleration Time (upper word) ^{*4}	0 to 15		
B+34	Axis 3 Deceleration Time (lower word) ^{*4}	0 to 15		
B+35	Axis 3 Deceleration Time (upper word) ^{*4}	0 to 15		
B+36	Axis 4 Direct Operation Command Memory Area	0 to 15		
B+37	Axis 4 Rotation Axis Direction	0 to 15		
B+38	Axis 4 Command Position (lower word)	0 to 15		
B+39	Axis 4 Command Position (upper word)	0 to 15		
B+40	Axis 4 Command Speed (lower word)	0 to 15		
B+41	Axis 4 Command Speed (upper word)	0 to 15		
B+42	Axis 4 Option Input 1 ^{*1}	0 to 15		
B+43	Axis 4 Option Input 2 ^{*1}	0 to 15		
B+44	Axis 4 Acceleration Time (lower word) ^{*4}	0 to 15		
B+45	Axis 4 Acceleration Time (upper word) ^{*4}	0 to 15		
B+46	Axis 4 Deceleration Time (lower word) ^{*4}	0 to 15		

Words	Name	Bit	Bit name	Function
B+47	Axis 4 Deceleration Time (upper word) ^{*4}	0 to 15		Refer to the description for axis 1. These words are not used for a two-axis PCU.
B+48	Axis 5 Direct Operation Command Memory Area	0 to 15		
B+49	Axis 5 Rotation Axis Direction	0 to 15		
B+50	Axis 5 Command Position (lower word)	0 to 15		
B+51	Axis 5 Command Position (upper word)	0 to 15		
B+52	Axis 5 Command Speed (lower word)	0 to 15		
B+53	Axis 5 Command Speed (upper word)	0 to 15		
B+54	Axis 5 Option Input 1 ^{*1}	0 to 15		
B+55	Axis 5 Option Input 2 ^{*1}	0 to 15		
B+56	Axis 5 Acceleration Time (lower word) ^{*4}	0 to 15		
B+57	Axis 5 Acceleration Time (upper word) ^{*4}	0 to 15		
B+58	Axis 5 Deceleration Time (lower word) ^{*4}	0 to 15		
B+59	Axis 5 Deceleration Time (upper word) ^{*4}	0 to 15		
B+60	Axis 6 Direct Operation Command Memory Area	0 to 15		Refer to the description for axis 1. These words are not used for a two-axis or four-axis PCU.
B+61	Axis 6 Rotation Axis Direction	0 to 15		
B+62	Axis 6 Command Position (lower word)	0 to 15		
B+63	Axis 6 Command Position (upper word)	0 to 15		
B+64	Axis 6 Command Speed (lower word)	0 to 15		
B+65	Axis 6 Command Speed (upper word)	0 to 15		
B+66	Axis 6 Option Input 1 ^{*1}	0 to 15		
B+67	Axis 6 Option Input 2 ^{*1}	0 to 15		
B+68	Axis 6 Acceleration Time (lower word) ^{*4}	0 to 15		
B+69	Axis 6 Acceleration Time (upper word) ^{*4}	0 to 15		
B+70	Axis 6 Deceleration Time (lower word) ^{*4}	0 to 15		
B+71	Axis 6 Deceleration Time (upper word) ^{*4}	0 to 15		
B+72	Axis 7 Direct Operation Command Memory Area	0 to 15		

6-6 Operation Memory Areas

Words	Name	Bit	Bit name	Function
B+73	Axis 7 Rotation Axis Direction	0 to 15		<p>Refer to the description for axis 1.</p> <p>These words are not used for a two-axis or four-axis PCU.</p>
B+74	Axis 7 Command Position (lower word)	0 to 15		
B+75	Axis 7 Command Position (upper word)	0 to 15		
B+76	Axis 7 Command Speed (lower word)	0 to 15		
B+77	Axis 7 Command Speed (upper word)	0 to 15		
B+78	Axis 7 Option Input 1 ^{*1}	0 to 15		
B+79	Axis 7 Option Input 2 ^{*1}	0 to 15		
B+80	Axis 7 Acceleration Time (lower word) ^{*4}	0 to 15		
B+81	Axis 7 Acceleration Time (upper word) ^{*4}	0 to 15		
B+82	Axis 7 Deceleration Time (lower word) ^{*4}	0 to 15		
B+83	Axis 7 Deceleration Time (upper word) ^{*4}	0 to 15		
B+84	Axis 8 Direct Operation Command Memory Area	0 to 15		
B+85	Axis 8 Rotation Axis Direction	0 to 15		
B+86	Axis 8 Command Position (lower word)	0 to 15		
B+87	Axis 8 Command Position (upper word)	0 to 15		
B+88	Axis 8 Command Speed (lower word)	0 to 15		
B+89	Axis 8 Command Speed (upper word)	0 to 15		
B+90	Axis 8 Option Input 1 ^{*1}	0 to 15		
B+91	Axis 8 Option Input 2 ^{*1}	0 to 15		
B+92	Axis 8 Acceleration Time (lower word) ^{*4}	0 to 15		
B+93	Axis 8 Acceleration Time (upper word) ^{*4}	0 to 15		
B+94	Axis 8 Deceleration Time (lower word) ^{*4}	0 to 15		
B+95	Axis 8 Deceleration Time (upper word) ^{*4}	0 to 15		
B+96	Axis 9 Direct Operation Command Memory Area	0 to 15		
B+97	Axis 9 Rotation Axis Direction	0 to 15		
B+98	Axis 9 Command Position (lower word)	0 to 15		

Words	Name	Bit	Bit name	Function
B+99	Axis 9 Command Position (upper word)	0 to 15		Refer to the description for axis 1. These words are not used for a two-axis or four-axis PCU.
B+100	Axis 9 Command Speed (lower word)	0 to 15		
B+101	Axis 9 Command Speed (upper word)	0 to 15		
B+102	Axis 9 Option Input 1 ^{*1}	0 to 15		
B+103	Axis 9 Option Input 2 ^{*1}	0 to 15		
B+104	Axis 9 Acceleration Time (lower word) ^{*4}	0 to 15		
B+105	Axis 9 Acceleration Time (upper word) ^{*4}	0 to 15		
B+106	Axis 9 Deceleration Time (lower word) ^{*4}	0 to 15		
B+107	Axis 9 Deceleration Time (upper word) ^{*4}	0 to 15		
B+108	Axis 10 Direct Operation Command Memory Area	0 to 15		
B+109	Axis 10 Rotation Axis Direction	0 to 15		
B+110	Axis 10 Command Position (lower word)	0 to 15		
B+111	Axis 10 Command Position (upper word)	0 to 15		
B+112	Axis 10 Command Speed (lower word)	0 to 15		
B+113	Axis 10 Command Speed (upper word)	0 to 15		
B+114	Axis 10 Option Input 1 ^{*1}	0 to 15		
B+115	Axis 10 Option Input 2 ^{*1}	0 to 15		
B+116	Axis 10 Acceleration Time (lower word) ^{*4}	0 to 15		Refer to the description for axis 1. These words are not used for a two-axis, four-axis, or eight-axis PCU.
B+117	Axis 10 Acceleration Time (upper word) ^{*4}	0 to 15		
B+118	Axis 10 Deceleration Time (lower word) ^{*4}	0 to 15		
B+119	Axis 10 Deceleration Time (upper word) ^{*4}	0 to 15		
B+120	Axis 11 Direct Operation Command Memory Area	0 to 15		
B+121	Axis 11 Rotation Axis Direction	0 to 15		
B+122	Axis 11 Command Position (lower word)	0 to 15		
B+123	Axis 11 Command Position (upper word)	0 to 15		
B+124	Axis 11 Command Speed (lower word)	0 to 15		

6-6 Operation Memory Areas



Words	Name	Bit	Bit name	Function
B+125	Axis 11 Command Speed (upper word)	0 to 15		Refer to the description for axis 1. These words are not used for a two-axis, four-axis, or eight-axis PCU.
B+126	Axis 11 Option Input 1 ^{*1}	0 to 15		
B+127	Axis 11 Option Input 2 ^{*1}	0 to 15		
B+128	Axis 11 Acceleration Time (lower word) ^{*4}	0 to 15		
B+129	Axis 11 Acceleration Time (upper word) ^{*4}	0 to 15		
B+130	Axis 11 Deceleration Time (lower word) ^{*4}	0 to 15		
B+131	Axis 11 Deceleration Time (upper word) ^{*4}	0 to 15		
B+132	Axis 12 Direct Operation Command Memory Area	0 to 15		
B+133	Axis 12 Rotation Axis Direction	0 to 15		
B+134	Axis 12 Command Position (lower word)	0 to 15		
B+135	Axis 12 Command Position (upper word)	0 to 15		
B+136	Axis 12 Command Speed (lower word)	0 to 15		
B+137	Axis 12 Command Speed (upper word)	0 to 15		
B+138	Axis 12 Option Input 1 ^{*1}	0 to 15		
B+139	Axis 12 Option Input 2 ^{*1}	0 to 15		
B+140	Axis 12 Acceleration Time (lower word) ^{*4}	0 to 15		
B+141	Axis 12 Acceleration Time (upper word) ^{*4}	0 to 15		
B+142	Axis 12 Deceleration Time (lower word) ^{*4}	0 to 15		
B+143	Axis 12 Deceleration Time (upper word) ^{*4}	0 to 15		
B+144	Axis 13 Direct Operation Command Memory Area	0 to 15		
B+145	Axis 13 Rotation Axis Direction	0 to 15		
B+146	Axis 13 Command Position (lower word)	0 to 15		
B+147	Axis 13 Command Position (upper word)	0 to 15		
B+148	Axis 13 Command Speed (lower word)	0 to 15		
B+149	Axis 13 Command Speed (upper word)	0 to 15		
B+150	Axis 13 Option Input 1 ^{*1}	0 to 15		
B+151	Axis 13 Option Input 2 ^{*1}	0 to 15		

Words	Name	Bit	Bit name	Function
B+152	Axis 13 Acceleration Time (lower word) ^{*4}	0 to 15		
B+153	Axis 13 Acceleration Time (upper word) ^{*4}	0 to 15		
B+154	Axis 13 Deceleration Time (lower word) ^{*4}	0 to 15		
B+155	Axis 13 Deceleration Time (upper word) ^{*4}	0 to 15		
B+156	Axis 14 Direct Operation Command Memory Area	0 to 15		
B+157	Axis 14 Rotation Axis Direction	0 to 15		
B+158	Axis 14 Command Position (lower word)	0 to 15		
B+159	Axis 14 Command Position (upper word)	0 to 15		
B+160	Axis 14 Command Speed (lower word)	0 to 15		
B+161	Axis 14 Command Speed (upper word)	0 to 15		
B+162	Axis 14 Option Input 1 ^{*1}	0 to 15		
B+163	Axis 14 Option Input 2 ^{*1}	0 to 15		
B+164	Axis 14 Acceleration Time (lower word) ^{*4}	0 to 15	Refer to the description for axis 1. These words are not used for a two-axis, four-axis, or eight-axis PCU.	
B+165	Axis 14 Acceleration Time (upper word) ^{*4}	0 to 15		
B+166	Axis 14 Deceleration Time (lower word) ^{*4}	0 to 15		
B+167	Axis 14 Deceleration Time (upper word) ^{*4}	0 to 15		
B+168	Axis 15 Direct Operation Command Memory Area	0 to 15		
B+169	Axis 15 Rotation Axis Direction	0 to 15		
B+170	Axis 15 Command Position (lower word)	0 to 15		
B+171	Axis 15 Command Position (upper word)	0 to 15		
B+172	Axis 15 Command Speed (lower word)	0 to 15		
B+173	Axis 15 Command Speed (upper word)	0 to 15		
B+174	Axis 15 Option Input 1 ^{*1}	0 to 15		
B+175	Axis 15 Option Input 2 ^{*1}	0 to 15		
B+176	Axis 15 Acceleration Time (lower word) ^{*4}	0 to 15		
B+177	Axis 15 Acceleration Time (upper word) ^{*4}	0 to 15		

6-6 Operation Memory Areas



Words	Name	Bit	Bit name	Function
B+178	Axis 15 Deceleration Time (lower word) ^{*4}	0 to 15		Refer to the description for axis 1. These words are not used for a two-axis, four-axis, or eight-axis PCU.
B+179	Axis 15 Deceleration Time (upper word) ^{*4}	0 to 15		
B+180	Axis 16 Direct Operation Command Memory Area	0 to 15		
B+181	Axis 16 Rotation Axis Direction	0 to 15		
B+182	Axis 16 Command Position (lower word)	0 to 15		
B+183	Axis 16 Command Position (upper word)	0 to 15		
B+184	Axis 16 Command Speed (lower word)	0 to 15		
B+185	Axis 16 Command Speed (upper word)	0 to 15		
B+186	Axis 16 Option Input 1 ^{*1}	0 to 15		
B+187	Axis 16 Option Input 2 ^{*1}	0 to 15		
B+188	Axis 16 Acceleration Time (lower word) ^{*4}	0 to 15		
B+189	Axis 16 Acceleration Time (upper word) ^{*4}	0 to 15		
B+190	Axis 16 Deceleration Time (lower word) ^{*4}	0 to 15		
B+191	Axis 16 Deceleration Time (upper word) ^{*4}	0 to 15		

*1. Available with version 1.3 or later PCUs.

*2. Available only when the positive torque limit value(60E0h) is mapped.

*3. Available only when the reverse torque limit value (60E1h) is mapped.

*4. The setting of the Acceleration/Deceleration Time Selection parameter determines the operation of the acceleration and deceleration times. For information on the Acceleration/Deceleration Time Selection parameter, refer to *Acceleration/Deceleration Settings* on page 6-36 and *Acceleration/Deceleration Time Selection* on page 6-38.

Axis Status Memory Area

For information on the setting method for the Axis Status Memory Area, refer to *Axis Status Memory Area Selection* on page 6-19.

The following table shows the allocations when the First Word in the Axis Status Memory Area parameter is set to word "C."



Precautions for Correct Use

The Axis Status Memory Area is used as the Remote I/O Input Memory Area when connected to a device other than a OMNUC G5-series Servo Drive.

Words	Name	Bit	Bit name	Function
C	Axis 1 Manual Operation Command Acknowledged Flags	0	Servo Lock Acknowledged Flag	This flag turns ON to acknowledge the Servo Lock Bit.
		1	Drive Alarm Reset Acknowledged Flag	This flag turns ON to acknowledge the Drive Alarm Reset Bit.
		2	Deviation Counter Reset Acknowledged Flag	This flag turns ON to acknowledge the Deviation Counter Reset Bit.
		3	Forward Torque Limit Acknowledged Flag	This flag turns ON to acknowledge the Forward Torque Limit Bit.
		4	Reverse Torque Limit Acknowledged Flag	This flag turns ON to acknowledge the Reverse Torque Limit Bit.
		5	Override Enable Acknowledged Flag	This flag turns ON to acknowledge the Override Enable Bit.
		6	Jogging/Inching Speed Selection Acknowledged Flag	This flag turns ON to acknowledge the Jogging/Inching Speed Selection Bit.
		7	Forward Jogging/Inching Acknowledged Flag	This flag turns ON to acknowledge the Forward Jogging/Inching Bit.
		8	Reverse Jogging/Inching Acknowledged Flag	This flag turns ON to acknowledge the Reverse Jogging/Inching Bit.
		9	Not used.	Do not use.
		10	Origin Search Acknowledged Flag	This flag turns ON to acknowledge the Origin Search Bit.
		11	Origin Return Acknowledged Flag	This flag turns ON to acknowledge the Origin Return Bit.
		12	Not used.	Do not use.
		13	Immediate Stop Acknowledged Flag	This flag turns ON to acknowledge the Immediate Stop Bit.
		14	Deceleration Stop Acknowledged Flag	This flag turns ON to acknowledge the Deceleration Stop Bit.
15	Servo Unlock Acknowledged Flag	This flag turns ON to acknowledge the Servo Unlock Bit.		

6-6 Operation Memory Areas

Words	Name	Bit	Bit name	Function
C+1	Axis 1 Direct Operation Command Acknowledged Flags	0	Absolute Movement Acknowledged Flag	This flag turns ON to acknowledge the Absolute Movement Bit.
		1	Relative Movement Acknowledged Flag	This flag turns ON to acknowledge the Relative Movement Bit.
		2	Speed Control Acknowledged Flag	This flag turns ON to acknowledge the Speed Control Bit.
		3 to 4	Not used.	Do not use.
		5	Interrupt Feeding Specification Acknowledged Flag	This flag turns ON to acknowledge the Interrupt Feeding Specification Bit.
		6	Interrupt Input Mask/Present Position Latch Enable Acknowledged Flag	This flag turns ON to acknowledge the Interrupt Input Mask/Present Position Latch Enable Bit.
		7	Present Position Preset Acknowledged Flag	This flag turns ON to acknowledge the Present Position Preset Bit.
		8	Synchronous Feeding Position Acknowledged Flag ^{*1}	This flag turns ON to acknowledge the Synchronous Feeding Position Bit.
		9	Synchronous Feeding Velocity Acknowledged Flag ^{*1}	This flag turns ON to acknowledge the Synchronous Feeding Velocity Bit.
		10	Synchronous Feeding Torque Acknowledged Flag ^{*1}	This flag turns ON to acknowledge the Synchronous Feeding Torque Bit.
		11	Origin Position Latch Enable Acknowledged Flag ^{*1}	This flag turns ON to acknowledge the Origin Position Latch Enable Bit.
		12 to 13	Not used.	Do not use.
		14	Origin Position Latch Clear Acknowledged Flag ^{*1}	This flag turns ON to acknowledge the Origin Position Latch Completed Flag Clear Bit.
		15	Latch Completed Flag Clear Acknowledged Flag	This flag turns ON to acknowledge the Latch Completed Flag Clear Bit.

Words	Name	Bit	Bit name	Function
C+2	Axis 1 Command Status	0	Axis Busy Flag	This flag turns ON during axis operation. During memory operation, the Busy Flags for axes that are not assigned in the axis configuration will turn ON even if there is no axis operation.
		1	Jogging Enabled Flag	This flag turns ON when jogging can be started.
		2	Direct Operation Enabled Flag	This flag turns ON when direct operation can be started.
		3	Not used.	Do not use.
		4	Stop Input Flag	This flag will turn ON when the Immediate Stop Bit or the Deceleration Stop Bit is acknowledged or when the emergency stop input or deceleration input is received. Other start command bits will not be acknowledged while this flag is ON.
		5	Synchronous Group Stop Input Flag ^{*1}	This flag turns ON when the Synchronous Group Stop Bit in synchronized data is acknowledged and the system is stopped and when the Synchronous Group Stop Bit is ON.
		6	All Synchronized Unit Stop Input Flag ^{*1}	This flag turns ON when the All Synchronized Unit Stop Bit in synchronized data is acknowledged and the system is stopped and when the All Synchronized Unit Stop Bit is ON.
		7	High-speed PTP Start Acknowledged Flag	This flag turns ON to acknowledge a high-speed PTP start.
		8	Start Invalid Flag	This flag turns ON after the executed command has failed because it does not meet the conditions for starting the applicable function. This status is set when an operation cannot be started due to an error that occurs at the start of the command or because of the priority of the command.
		9	Deviation Counter Reset Acknowledged Flag	This flag turns ON if the Deviation Counter Reset Bit is not acknowledged after the Deviation Counter Reset Bit is output during an origin search operation.
		10 to 11	Not used.	Do not use.
		12	Stop Executed Flag	This flag turns ON when axis operation has stopped for one of the following reasons during manual operation or direct operation. <ul style="list-style-type: none"> ♦ Stopping when a deceleration stop is executed, the deviation counter is reset, or the servo is unlocked ♦ Stopping when an error occurs
		13	Positioning Operation Completed Flag	This flag turns ON when positioning, an origin search, or an origin return has been finished in direct operation or when jogging is stopped in direct operation.
14 to 15	Not used.	Do not use.		

6-6 Operation Memory Areas

Words	Name	Bit	Bit name	Function
C+3	Axis 1 Axis Operation Command Status	0	Servo Unlocked Flag	This flag is ON while the servo is unlocked for the axis.
		1	Servo Locked Flag	This flag is ON when the axis is stopped in servo lock status.
		2	Not used.	Do not use.
		3	Acceleration Flag	This flag is ON while the axis is accelerating to the target speed. This flag can also be used for path status during interpolation.
		4	Constant Speed Flag	This flag is ON while the axis is moving at a constant speed after reaching the target speed. This flag can also be used for path status during interpolation.
		5	Deceleration Flag	This flag is ON while the axis is decelerating to the target position or to the target speed. This flag can also be used for path status during interpolation.
		6	Pass Flag	This flag is ON during acceleration/deceleration to the target speed of the next sequence for the continuous 1 or continuous 3 operation patterns. This flag can also be used for path status during interpolation.
		7	Positioning Completed Waiting Flag	This flag is ON while waiting for axis positioning to be completed. This flag can also be used for path status during interpolation.
		8	Deceleration Stop Flag	This flag is ON until the axis stops for a deceleration stop during axis operation.
		9	Immediate Stop Flag	This flag is ON until the axis stops for an immediate stop during axis operation.
		10 to 15	Not used.	Do not use.
C+4	Axis 1 Operation Status	0	Origin Search Flag	This flag is ON during an origin search operation.
		1	Origin Return Flag	This flag is ON during an origin return operation.
		2	Not used.	Do not use.
		3	Jogging/Inching Flag	This flag is on during jogging or inching.
		4	Absolute Movement Flag	This flag is ON during an absolute movement. It is also ON until the interrupt feeding input is received.
		5	Relative Movement Flag	This flag is ON during a relative movement. It is also ON until the interrupt feeding input is received.

Words	Name	Bit	Bit name	Function
C+4 (continued)	Axis 1 Operation Status	6	Speed Control Flag	This flag is ON during speed control. It is also ON until the interrupt feeding input is received.
		7	Interrupt Feeding (Interrupt Input Waiting) Flag	This flag is ON during interrupt feeding until the interrupt input turns ON.
		8	Interrupt Feeding (Positioning) Flag	This flag is ON after the interrupt input turns ON during interrupt feeding.
		9 to 10	Not used.	Do not use.
		11	Memory Operation Flag	This flag is ON during memory operation.
		12	Not used.	Do not use.
		13	Synchronous Feeding Torque Flag ^{*1}	This flag is ON during synchronous feeding torque control operation. The axis movement reflects the command torque data stored in the Synchronous Data Link Memory Area.
		14	Synchronous Feeding Velocity Flag ^{*1}	This flag is ON during synchronous feeding velocity control operation. The axis movement reflects the command speed data stored in the Synchronous Data Link Memory Area.
		15	Synchronous Feeding Position Flag ^{*1}	This flag is ON during a synchronous feeding position operation. The axis movement reflects the position data for the auxiliary axis that is set with the Electric Shaft function and stored in the Synchronous Data Link Memory Area.
C+5	Axis 1 Control Status	0	Origin Defined Flag	This flag is ON while the origin is defined. OFF: Origin not defined. ON: Origin defined.
		1	Stopped at Origin Flag	This flag is ON while the axis is stopped within the positioning completed width. It will not turn ON unless the origin is defined.
		2	Latch Completed Flag	This flag turns ON when the present position has been latched.
		3	Origin Position Latch Completed Flag ^{*1}	This flag turns ON when the origin position has been latched.
		4	Command Present Position Overflow Flag	This flag turns ON when an overflow occurs in the command position in Linear Mode.
		5	Command Present Position Underflow Flag	This flag turns ON when an underflow occurs in the command position in Linear Mode.
		6	Feedback Present Position Overflow Flag	This flag turns ON when an overflow occurs in the feedback position in Linear Mode.
		7	Feedback Present Position Underflow Flag	This flag turns ON when an underflow occurs in the feedback position in Linear Mode.

6-6 Operation Memory Areas

Words	Name	Bit	Bit name	Function
C+5 (continued)	Axis 1 Control Status	8	Sensor Error Flag	This flag turns ON when an error is detected for an external sensor, such as for the emergency stop input or a limit input.
		9	Servo Error Flag	This flag turns ON when a Servo Drive alarm occurs.
		10	Execution Error Flag	This flag turns ON when an error, such as a multi-start error, occurs after execution of a command for axis operation due to an invalid execution condition or command value.
		11	Axis Warning Flag	This flag turns ON when a warning occurs in memory operation.
		12	Axis Error Flag	This flag turns ON when an axis error occurs.
		13	Zone 0 Flag	This flag is ON while the present position is in zone 0.
		14	Zone 1 Flag	This flag is ON while the present position is in zone 1.
C+6	Axis 1 External I/O Status	0	Servo ON Flag	This flag is ON while power is being supplied to the Servomotor.
		1	Alarm Reset Output Flag	This flag turns ON when an alarm reset is output.
		2	Deviation Counter Reset Output Flag	This flag turns ON when a deviation counter reset is output.
		3	Forward Torque Limit Output Flag	This flag turns ON when a forward torque limit is output.
		4	Reverse Torque Limit Output Flag	This flag turns ON when a reverse torque limit is output.
		5	Main Circuit Status Flag	This flag turns ON when a voltage is supplied to the main circuits.
		6	Servo Drive Warning Input Flag	This flag turns ON when a Servo Drive warning occurs.
		7	Servo Ready Flag	This flag turns ON when the servo is ready.
		8	Forward Limit Input Flag	This flag is ON while the forward limit input is being received.
		9	Reverse Limit Input Flag	This flag is ON while the reverse limit input is being received.
		10	Origin Proximity Input Flag	This flag is ON while the origin proximity input is being received.
		11	Origin Input Flag	This flag is ON while the origin input is being received.
		12	Interrupt Input Flag	This flag is ON while the interrupt input is being received.
		13	Emergency Stop Input Flag	This flag is ON while the emergency input is being received.
		14	Positioning Completed Input Flag	This flag is ON while the axis is within the positioning completed width.
15	Drive Alarm Input Flag	This flag turns ON when a drive alarm occurs.		

Words	Name	Bit	Bit name	Function
C+7	Axis 1 Error Code	0 to 15		This word contains the axis error code.
C+8	Axis 1 Command Present Position (lower word)	0 to 15		These words contain the present command position.
C+9	Axis 1 Command Present Position (upper word)	0 to 15		
C+10	Axis 1 Expanded Monitor (lower word)	0 to 15		These words contain the monitor value that is specified by the Expanded Monitor Type axis parameter. For details, refer to <i>Expanded Monitor Settings</i> on page 6-59.
C+11	Axis 1 Expanded Monitor (upper word)	0 to 15		
C+12	Not used.	0 to 15		Do not use.
C+13	Axis 2 Manual Operation Command Acknowledged Flags	0 to 15		Refer to the description for axis 1.
C+14	Axis 2 Direct Operation Command Acknowledged Flags	0 to 15		
C+15	Axis 2 Command Status	0 to 15		
C+16	Axis 2 Axis Operation Command Status	0 to 15		
C+17	Axis 2 Operation Status	0 to 15		
C+18	Axis 2 Control Status	0 to 15		
C+19	Axis 2 External I/O Status	0 to 15		
C+20	Axis 2 Error Code	0 to 15		
C+21	Axis 2 Command Present Position (lower word)	0 to 15		Refer to the description for axis 1.
C+22	Axis 2 Command Present Position (upper word)	0 to 15		
C+23	Axis 2 Expanded Monitor (lower word)	0 to 15		
C+24	Axis 2 Expanded Monitor (upper word)	0 to 15		
C+25	Not used.	0 to 15		Do not use.
C+26	Axis 3 Manual Operation Command Acknowledged Flags	0 to 15		Refer to the description for axis 1. These words are not used for a two-axis PCU.
C+27	Axis 3 Direct Operation Command Acknowledged Flags	0 to 15		
C+28	Axis 3 Command Status	0 to 15		
C+29	Axis 3 Axis Operation Command Status	0 to 15		
C+30	Axis 3 Operation Status	0 to 15		
C+31	Axis 3 Control Status	0 to 15		
C+32	Axis 3 External I/O Status	0 to 15		
C+33	Axis 3 Error Code	0 to 15		
C+34	Axis 3 Command Present Position (lower word)	0 to 15		

6-6 Operation Memory Areas

Words	Name	Bit	Bit name	Function	
C+35	Axis 3 Command Present Position (upper word)	0 to 15		Refer to the description for axis 1. These words are not used for a two-axis PCU.	
C+36	Axis 3 Expanded Monitor (lower word)	0 to 15			
C+37	Axis 3 Expanded Monitor (upper word)	0 to 15			
C+38	Not used.	0 to 15	Do not use.		
C+39	Axis 4 Manual Operation Command Acknowledged Flags	0 to 15		Refer to the description for axis 1. These words are not used for a two-axis PCU.	
C+40	Axis 4 Direct Operation Command Acknowledged Flags	0 to 15			
C+41	Axis 4 Command Status	0 to 15			
C+42	Axis 4 Axis Operation Command Status	0 to 15			
C+43	Axis 4 Operation Status	0 to 15			
C+44	Axis 4 Control Status	0 to 15			
C+45	Axis 4 External I/O Status	0 to 15			
C+46	Axis 4 Error Code	0 to 15			
C+47	Axis 4 Command Present Position (lower word)	0 to 15			
C+48	Axis 4 Command Present Position (upper word)	0 to 15			
C+49	Axis 4 Expanded Monitor (lower word)	0 to 15			
C+50	Axis 4 Expanded Monitor (upper word)	0 to 15			
C+51	Not used.	0 to 15	Do not use.		
C+52	Axis 5 Manual Operation Command Acknowledged Flags	0 to 15			Refer to the description for axis 1. These words are not used for a two-axis or four-axis PCU.
C+53	Axis 5 Direct Operation Command Acknowledged Flags	0 to 15			
C+54	Axis 5 Command Status	0 to 15			
C+55	Axis 5 Axis Operation Command Status	0 to 15			
C+56	Axis 5 Operation Status	0 to 15			
C+57	Axis 5 Control Status	0 to 15			
C+58	Axis 5 External I/O Status	0 to 15			
C+59	Axis 5 Error Code	0 to 15			
C+60	Axis 5 Command Present Position (lower word)	0 to 15			

Words	Name	Bit	Bit name	Function
C+61	Axis 5 Command Present Position (upper word)	0 to 15		Refer to the description for axis 1. These words are not used for a two-axis or four-axis PCU.
C+62	Axis 5 Expanded Monitor (lower word)	0 to 15		
C+63	Axis 5 Expanded Monitor (upper word)	0 to 15		
C+64	Not used.	0 to 15	Do not use.	
C+65	Axis 6 Manual Operation Command Acknowledged Flags	0 to 15		Refer to the description for axis 1. These words are not used for a two-axis or four-axis PCU.
C+66	Axis 6 Direct Operation Command Acknowledged Flags	0 to 15		
C+67	Axis 6 Command Status	0 to 15		
C+68	Axis 6 Axis Operation Command Status	0 to 15		
C+69	Axis 6 Operation Status	0 to 15		
C+70	Axis 6 Control Status	0 to 15		
C+71	Axis 6 External I/O Status	0 to 15		
C+72	Axis 6 Error Code	0 to 15		
C+73	Axis 6 Command Present Position (lower word)	0 to 15		
C+74	Axis 6 Command Present Position (upper word)	0 to 15		
C+75	Axis 6 Expanded Monitor (lower word)	0 to 15		
C+76	Axis 6 Expanded Monitor (upper word)	0 to 15		
C+77	Not used.	0 to 15	Do not use.	
C+78	Axis 7 Manual Operation Command Acknowledged Flags	0 to 15		
C+79	Axis 7 Direct Operation Command Acknowledged Flags	0 to 15		
C+80	Axis 7 Command Status	0 to 15		
C+81	Axis 7 Axis Operation Command Status	0 to 15		
C+82	Axis 7 Operation Status	0 to 15		
C+83	Axis 7 Control Status	0 to 15		
C+84	Axis 7 External I/O Status	0 to 15		
C+85	Axis 7 Error Code	0 to 15		
C+86	Axis 7 Command Present Position (lower word)	0 to 15		
C+87	Axis 7 Command Present Position (upper word)	0 to 15		
C+88	Axis 7 Expanded Monitor (lower word)	0 to 15		

6-6 Operation Memory Areas

Words	Name	Bit	Bit name	Function	
C+89	Axis 7 Expanded Monitor (upper word)	0 to 15		Refer to the description for axis 1. These words are not used for a two-axis or four-axis PCU.	
C+90	Not used.	0 to 15		Do not use.	
C+91	Axis 8 Manual Operation Command Acknowledged Flags	0 to 15		Refer to the description for axis 1. These words are not used for a two-axis or four-axis PCU.	
C+92	Axis 8 Direct Operation Command Acknowledged Flags	0 to 15			
C+93	Axis 8 Command Status	0 to 15			
C+94	Axis 8 Axis Operation Command Status	0 to 15			
C+95	Axis 8 Operation Status	0 to 15			
C+96	Axis 8 Control Status	0 to 15			
C+97	Axis 8 External I/O Status	0 to 15			
C+98	Axis 8 Error Code	0 to 15			
C+99	Axis 8 Command Present Position (lower word)	0 to 15			
C+100	Axis 8 Command Present Position (upper word)	0 to 15			
C+101	Axis 8 Expanded Monitor (lower word)	0 to 15			
C+102	Axis 8 Expanded Monitor (upper word)	0 to 15			Refer to the description for axis 1. These words are not used for a two-axis or four-axis PCU.
C+103	Not used.	0 to 15			Do not use.
C+104	Axis 9 Manual Operation Command Acknowledged Flags	0 to 15		Refer to the description for axis 1. These words are not used for a two-axis, four-axis, or eight-axis PCU.	
C+105	Axis 9 Direct Operation Command Acknowledged Flags	0 to 15			
C+106	Axis 9 Command Status	0 to 15			
C+107	Axis 9 Axis Operation Command Status	0 to 15			
C+108	Axis 9 Operation Status	0 to 15			
C+109	Axis 9 Control Status	0 to 15			
C+110	Axis 9 External I/O Status	0 to 15			
C+111	Axis 9 Error Code	0 to 15			
C+112	Axis 9 Command Present Position (lower word)	0 to 15			
C+113	Axis 9 Command Present Position (upper word)	0 to 15			
C+114	Axis 9 Expanded Monitor (lower word)	0 to 15			
C+115	Axis 9 Expanded Monitor (upper word)	0 to 15			
C+116	Not used.	0 to 15			Do not use.

Words	Name	Bit	Bit name	Function	
C+117	Axis 10 Manual Operation Command Acknowledged Flags	0 to 15	Refer to the description for axis 1. These words are not used for a two-axis, four-axis, or eight-axis PCU.		
C+118	Axis 10 Direct Operation Command Acknowledged Flags	0 to 15			
C+119	Axis 10 Command Status	0 to 15			
C+120	Axis 10 Axis Operation Command Status	0 to 15			
C+121	Axis 10 Operation Status	0 to 15			
C+122	Axis 10 Control Status	0 to 15			
C+123	Axis 10 External I/O Status	0 to 15			
C+124	Axis 10 Error Code	0 to 15			
C+125	Axis 10 Command Present Position (lower word)	0 to 15			
C+126	Axis 10 Command Present Position (upper word)	0 to 15			
C+127	Axis 10 Expanded Monitor (lower word)	0 to 15			
C+128	Axis 10 Expanded Monitor (upper word)	0 to 15			
C+129	Not used.	0 to 15			Do not use.
C+130	Axis 11 Manual Operation Command Acknowledged Flags	0 to 15			Refer to the description for axis 1. These words are not used for a two-axis, four-axis, or eight-axis PCU.
C+131	Axis 11 Direct Operation Command Acknowledged Flags	0 to 15			
C+132	Axis 11 Command Status	0 to 15			
C+133	Axis 11 Axis Operation Command Status	0 to 15			
C+134	Axis 11 Operation Status	0 to 15			
C+135	Axis 11 Control Status	0 to 15			
C+136	Axis 11 External I/O Status	0 to 15			
C+137	Axis 11 Error Code	0 to 15			
C+138	Axis 11 Command Present Position (lower word)	0 to 15			
C+139	Axis 11 Command Present Position (upper word)	0 to 15			
C+140	Axis 11 Expanded Monitor (lower word)	0 to 15			
C+141	Axis 11 Expanded Monitor (upper word)	0 to 15			
C+142	Not used.	0 to 15	Do not use.		

6-6 Operation Memory Areas

Words	Name	Bit	Bit name	Function	
C+143	Axis 12 Manual Operation Command Acknowledged Flags	0 to 15		Refer to the description for axis 1. These words are not used for a two-axis, four-axis, or eight-axis PCU.	
C+144	Axis 12 Direct Operation Command Acknowledged Flags	0 to 15			
C+145	Axis 12 Command Status	0 to 15			
C+146	Axis 12 Axis Operation Command Status	0 to 15			
C+147	Axis 12 Operation Status	0 to 15			
C+148	Axis 12 Control Status	0 to 15			
C+149	Axis 12 External I/O Status	0 to 15			
C+150	Axis 12 Error Code	0 to 15			
C+151	Axis 12 Command Present Position (lower word)	0 to 15			
C+152	Axis 12 Command Present Position (upper word)	0 to 15			
C+153	Axis 12 Expanded Monitor (lower word)	0 to 15			
C+154	Axis 12 Expanded Monitor (upper word)	0 to 15			
C+155	Not used.	0 to 15	Do not use.		
C+156	Axis 13 Manual Operation Command Acknowledged Flags	0 to 15			Refer to the description for axis 1. These words are not used for a two-axis, four-axis, or eight-axis PCU.
C+157	Axis 13 Direct Operation Command Acknowledged Flags	0 to 15			
C+158	Axis 13 Command Status	0 to 15			
C+159	Axis 13 Axis Operation Command Status	0 to 15			
C+160	Axis 13 Operation Status	0 to 15			
C+161	Axis 13 Control Status	0 to 15			
C+162	Axis 13 External I/O Status	0 to 15			
C+163	Axis 13 Error Code	0 to 15			
C+164	Axis 13 Command Present Position (lower word)	0 to 15			
C+165	Axis 13 Command Present Position (upper word)	0 to 15			
C+166	Axis 13 Expanded Monitor (lower word)	0 to 15			
C+167	Axis 13 Expanded Monitor (upper word)	0 to 15			
C+168	Not used.	0 to 15	Do not use.		

Words	Name	Bit	Bit name	Function
C+169	Axis 14 Manual Operation Command Acknowledged Flags	0 to 15		Refer to the description for axis 1. These words are not used for a two-axis, four-axis, or eight-axis PCU.
C+170	Axis 14 Direct Operation Command Acknowledged Flags	0 to 15		
C+171	Axis 14 Command Status	0 to 15		
C+172	Axis 14 Axis Operation Command Status	0 to 15		
C+173	Axis 14 Operation Status	0 to 15		
C+174	Axis 14 Control Status	0 to 15		
C+175	Axis 14 External I/O Status	0 to 15		
C+176	Axis 14 Error Code	0 to 15		
C+177	Axis 14 Command Present Position (lower word)	0 to 15		
C+178	Axis 14 Command Present Position (upper word)	0 to 15		
C+179	Axis 14 Expanded Monitor (lower word)	0 to 15		
C+180	Axis 14 Expanded Monitor (upper word)	0 to 15		
C+181	Not used.	0 to 15	Do not use.	
C+182	Axis 15 Manual Operation Command Acknowledged Flags	0 to 15		
C+183	Axis 15 Direct Operation Command Acknowledged Flags	0 to 15		
C+184	Axis 15 Command Status	0 to 15		
C+185	Axis 15 Axis Operation Command Status	0 to 15		
C+186	Axis 15 Operation Status	0 to 15		
C+187	Axis 15 Control Status	0 to 15		
C+188	Axis 15 External I/O Status	0 to 15		
C+189	Axis 15 Error Code	0 to 15		
C+190	Axis 15 Command Present Position (lower word)	0 to 15		
C+191	Axis 15 Command Present Position (upper word)	0 to 15		
C+192	Axis 15 Expanded Monitor (lower word)	0 to 15		
C+193	Axis 15 Expanded Monitor (upper word)	0 to 15		
C+194	Not used.	0 to 15	Do not use.	

6-6 Operation Memory Areas



Words	Name	Bit	Bit name	Function
C+195	Axis 16 Manual Operation Command Acknowledged Flags	0 to 15		Refer to the description for axis 1. These words are not used for a two-axis, four-axis, or eight-axis PCU.
C+196	Axis 16 Direct Operation Command Acknowledged Flags	0 to 15		
C+197	Axis 16 Command Status	0 to 15		
C+198	Axis 16 Axis Operation Command Status	0 to 15		
C+199	Axis 16 Operation Status	0 to 15		
C+200	Axis 16 Control Status	0 to 15		
C+201	Axis 16 External I/O Status	0 to 15		
C+202	Axis 16 Error Code	0 to 15		
C+203	Axis 16 Command Present Position (lower word)	0 to 15		
C+204	Axis 16 Command Present Position (upper word)	0 to 15		
C+205	Axis 16 Expanded Monitor (lower word)	0 to 15		
C+206	Axis 16 Expanded Monitor (upper word)	0 to 15		
C+207	Not used.	0 to 15	Do not use.	

*1. Available with version 1.3 or later PCUs.

Memory Operation Command Memory Area

For information on the setting method for the Memory Operation Command Memory Area, refer to *Memory Operation Command Memory Area Selection* on page 6-18.

The following table shows the allocations when the First Word in the Memory Operation Command Memory Area parameter is set to word "D."

Words	Name	Bit	Bit name	Function
D	Task 1 Memory Operation Command Area	0	Sequence Number Enable Bit	Turn ON this bit to enable the sequence number set in the operation data area when memory operation starts. ON: Enabled, OFF: Disabled
		1	Memory Operation Start Bit	Turn ON this bit to start memory operation.
		2	Memory Operation Individual Start Bit	All sequences will be executed as independent operations, except when the command is set to END.
		3	Not used.	Do not use.
		4	M Code Reset Bit	Turn ON this bit to reset the M code.
		5	Teaching Bit	Turn ON this bit to perform teaching.
		6 to 14	Not used.	Do not use.
		15	Memory Operation Stop Bit	Turn ON this bit to decelerate memory operation to a stop.
D+1	Task 1 Sequence Number	0 to 15	Specify the starting sequence number for memory operation. Set a sequence number between 1 and 500 in hexadecimal.	
D+2	Task 1 Teaching Address	0 to 15	Set the position data number (sequence number) to use for position teaching. Set a sequence number between 1 and 500 in hexadecimal.	
D+3	Task 2 Memory Operation Command Area	0 to 15	Refer to the description for task 1.	
D+4	Task 2 Sequence Number	0 to 15		
D+5	Task 2 Teaching Address	0 to 15		
D+6	Task 3 Memory Operation Command Area	0 to 15	Refer to the description for task 1.	
D+7	Task 3 Sequence Number	0 to 15		
D+8	Task 3 Teaching Address	0 to 15		
D+9	Task 4 Memory Operation Command Area	0 to 15	These words are not used for a two-axis PCU.	
D+10	Task 4 Sequence Number	0 to 15		
D+11	Task 4 Teaching Address	0 to 15		

Memory Operation Start Bit (Word D, Bit 1)

When you use the Memory Operation Start Bit to start memory operation, the next sequence number will be automatically executed after executing the starting sequence.

Execution will continue until END is executed in a sequence data command.

For details, refer to *Starting Memory Operation* on page 8-24.

Memory Operation Individual Start Bit (Word D, Bit 2)

When you use the Memory Operation Individual Start Bit to start memory operation, all operations are performed as if the end patterns were set to Individual, regardless of sequence data.

Use the Memory Operation Individual Start Bit to debug sequences one at a time.

The operation that is set for the specified sequence number is executed, the Executing Sequence Number is updated in memory based on the execution result, and then the operation ends.

For details, refer to *Starting Memory Operation* on page 8-24.

Memory Operation Status Memory Area

For information on the setting method for Memory Operation Status Memory Area, refer to *Memory Operation Status Memory Area Selection* on page 6-20.

The following table shows the allocations when the First Word in the Memory Operation Status Memory Area parameter is set to word "E."

Words	Name	Bit	Bit name	Function
E	Task 1 Memory Operation Command Acknowledged Flags	0	Sequence Number Enable Acknowledged Flag	This flag turns ON to acknowledge the Sequence Number Enable Bit.
		1	Memory Operation Start Acknowledged Flag	This flag turns ON to acknowledge the Memory Operation Start Bit.
		2	Memory Operation Individual Start Acknowledged Flag	This flag turns ON to acknowledge the Memory Operation Independent Start Bit.
		3	Not used.	Do not use.
		4	M Code Reset Acknowledged Flag	This flag turns ON to acknowledge the M Code Reset Bit.
		5	Teaching Acknowledged Flag	This flag turns ON to acknowledge the Teaching Bit.
		6 to 14	Not used.	Do not use.
		15	Memory Operation Stop Acknowledged Flag	This flag turns ON to acknowledge the Memory Operation Stop Bit.

Words	Name	Bit	Bit name	Function
E+1	Task 1 Memory Operation Command Status	0	Memory Operation Busy Flag	This flag is ON while a task command is being executed. It remains ON while a task configuration axis is busy or a task function is being executed.
		1	Memory Operation Start Enabled Flag	This flag is ON while a task can be started. It is OFF while a task configuration axis is busy or a task function is being executed.
		2 to 3	Not used.	Do not use.
		4	Memory Operation Stop Input Flag	This flag is ON while decelerating after receiving a memory operation stop command. Start commands will not be acknowledged while this flag is ON.
		5 to 7	Not used.	Do not use.
		8	Memory Operation Start Invalid Flag	This flag turns ON when an error, such as a memory operation multi-start error, occurs after execution of a command for memory operation due to an invalid execution condition or command value.
		9	Teaching Invalid Flag	This flag turns ON when the PCU could not acknowledge a teaching command.
		10 to 11	Not used.	Do not use.
		12	Memory Operation Stop Executed Flag	This flag turns ON when memory operation has stopped after receiving a memory operation stop command, after an error stop, or after receiving a command accompanied by a single-axis stop during memory operation.
		13	Memory Operation Completed Flag	This flag turns ON when memory operation has stopped normally.
		14	Teaching Completed Flag	This flag turns ON when a teaching command is completed.
		15	Not used.	Do not use.
E+2	Task 1 Memory Operation Control Status	0	Memory Operation Stopped Flag	This flag is ON while memory operation is not being executed.
		1	Memory Operation Waiting Flag	This flag is ON while memory operation is on standby. It turns ON when memory operation stops without executing END.
		2	Memory Operation Axis Operating Flag	This flag is ON while an axis is operating during memory operation. It is ON while any configuration axis is operating.
		3	Condition Input Waiting Flag	This flag is ON while the PCU is waiting for the input of conditions during memory operation.
		4	Dwell Timer Waiting Flag	This flag is ON while the PCU is waiting for the dwell time during memory operation.
		5	M Code Reset Waiting Flag	This flag is ON while the PCU is waiting for the M code to be reset during memory operation.
		6	M Strobe Flag	This flag is ON while there is an M code output during memory operation.
		7 to 9	Not used.	Do not use.

6-6 Operation Memory Areas

Words	Name	Bit	Bit name	Function		
E+2 (continued)	Task 1 Memory Operation Control Status	10	Memory Operation Execution Error Flag	This flag turns ON when an operation error occurs for the task function.		
		11	Memory Operation Warning Flag	This flag turns ON when a warning occurs in memory operation.		
		12	Memory Operation Error Flag	This flag turns ON when a memory operation error occurs.		
		13 to 15	Not used.	Do not use.		
E+3	Task 1 Memory Operation Error Code	0 to 15	This word contains the task error code.			
E+4	Task 1 Executing Sequence Number	0 to 15	This word contains the number of the sequence that is being executed in memory operation.			
E+5	Task 1 M Code	0 to 15	This word contains the M code (output code) for memory operation.			
E+6	Task 2 Memory Operation Command Acknowledged Flags	0 to 15	Refer to the description for task 1.			
E+7	Task 2 Memory Operation Command Status	0 to 15				
E+8	Task 2 Memory Operation Control Status	0 to 15				
E+9	Task 2 Memory Operation Error Code	0 to 15				
E+10	Task 2 Executing Sequence Number	0 to 15				
E+11	Task 2 M Code	0 to 15				
E+12	Task 3 Memory Operation Command Acknowledged Flags	0 to 15			Refer to the description for task 1.	
E+13	Task 3 Memory Operation Command Status	0 to 15				
E+14	Task 3 Memory Operation Control Status	0 to 15				
E+15	Task 3 Memory Operation Error Code	0 to 15				
E+16	Task 3 Executing Sequence Number	0 to 15				
E+17	Task 3 M Code	0 to 15				
E+18	Task 4 Memory Operation Command Acknowledged Flags	0 to 15	These words are not used for a two-axis PCU.			
E+19	Task 4 Memory Operation Command Status	0 to 15				
E+20	Task 4 Memory Operation Control Status	0 to 15				
E+21	Task 4 Memory Operation Error Code	0 to 15				
E+22	Task 4 Executing Sequence Number	0 to 15				
E+23	Task 4 M Code	0 to 15				

Expanded Monitor Memory Area

For information on the setting method for the Expanded Monitor Memory Area, refer to *Expanded Monitor Memory Area Selection* on page 6-21.

The words in the Expanded Monitor Memory Area are allocated as shown below. F is the first word of the Expanded Monitor Memory Area.



Precautions for Correct Use

The Expanded Monitor Memory Area is used as the Remote I/O Input Memory Area when connected to a device other than a OMNUC G5-series Servo Drive.

Words	Name	Function
F	Axis 1 Expanded Monitor 2 (lower word)	These words contain the monitor value that is specified by the Expanded Monitor 2 Type axis parameter.
F+1	Axis 1 Expanded Monitor 2 (upper word)	
F+2	Axis 1 Expanded Monitor 3 (lower word)	These words contain the monitor value that is specified by the Expanded Monitor 3 Type axis parameter.
F+3	Axis 1 Expanded Monitor 3 (upper word)	
F+4	Axis 1 Expanded Monitor 4 (lower word)	These words contain the monitor value that is specified by the Expanded Monitor 4 Type axis parameter.
F+5	Axis 1 Expanded Monitor 4 (upper word)	
F+6	Axis 1 Expanded Monitor 5 (lower word)	These words contain the monitor value that is specified by the Expanded Monitor 5 Type axis parameter.
F+7	Axis 1 Expanded Monitor 5 (upper word)	
F+8	Axis 1 Expanded Monitor 6 (lower word)	These words contain the monitor value that is specified by the Expanded Monitor 6 Type axis parameter.
F+9	Axis 1 Expanded Monitor 6 (upper word)	
F+10	Not used.	Do not use.
F+11	Not used.	
F+12	Not used.	
F+13	Not used.	
F+14	Not used.	
F+15	Not used.	

6-6 Operation Memory Areas



Words	Name	Function
F+16	Axis 2 Expanded Monitor 2 (lower word)	Refer to the description for axis 1.
F+17	Axis 2 Expanded Monitor 2 (upper word)	
F+18	Axis 2 Expanded Monitor 3 (lower word)	
F+19	Axis 2 Expanded Monitor 3 (upper word)	
F+20	Axis 2 Expanded Monitor 4 (lower word)	
F+21	Axis 2 Expanded Monitor 4 (upper word)	
F+22	Axis 2 Expanded Monitor 5 (lower word)	
F+23	Axis 2 Expanded Monitor 5 (upper word)	
F+24	Axis 2 Expanded Monitor 6 (lower word)	
F+25	Axis 2 Expanded Monitor 6 (upper word)	
F+26	Not used.	
F+27	Not used.	
F+28	Not used.	
F+29	Not used.	
F+30	Not used.	
F+31	Not used.	
F+32	Axis 3 Expanded Monitor 2 (lower word)	Refer to the description for axis 1. These words are not used for a two-axis PCU.
F+33	Axis 3 Expanded Monitor 2 (upper word)	
F+34	Axis 3 Expanded Monitor 3 (lower word)	
F+35	Axis 3 Expanded Monitor 3 (upper word)	
F+36	Axis 3 Expanded Monitor 4 (lower word)	
F+37	Axis 3 Expanded Monitor 4 (upper word)	
F+38	Axis 3 Expanded Monitor 5 (lower word)	
F+39	Axis 3 Expanded Monitor 5 (upper word)	
F+40	Axis 3 Expanded Monitor 6 (lower word)	
F+41	Axis 3 Expanded Monitor 6 (upper word)	

Words	Name	Function
F+42	Not used.	Do not use.
F+43	Not used.	
F+44	Not used.	
F+45	Not used.	
F+46	Not used.	
F+47	Not used.	
F+48	Axis 4 Expanded Monitor 2 (lower word)	Refer to the description for axis 1. These words are not used for a two-axis PCU.
F+49	Axis 4 Expanded Monitor 2 (upper word)	
F+50	Axis 4 Expanded Monitor 3 (lower word)	
F+51	Axis 4 Expanded Monitor 3 (upper word)	
F+52	Axis 4 Expanded Monitor 4 (lower word)	
F+53	Axis 4 Expanded Monitor 4 (upper word)	
F+54	Axis 4 Expanded Monitor 5 (lower word)	
F+55	Axis 4 Expanded Monitor 5 (upper word)	
F+56	Axis 4 Expanded Monitor 6 (lower word)	
F+57	Axis 4 Expanded Monitor 6 (upper word)	
F+58	Not used.	Do not use.
F+59	Not used.	
F+60	Not used.	
F+61	Not used.	
F+62	Not used.	
F+63	Not used.	
F+64	Axis 5 Expanded Monitor 2 (lower word)	Refer to the description for axis 1. These words are not used for a two-axis or four-axis PCU.
F+65	Axis 5 Expanded Monitor 2 (upper word)	
F+66	Axis 5 Expanded Monitor 3 (lower word)	
F+67	Axis 5 Expanded Monitor 3 (upper word)	
F+68	Axis 5 Expanded Monitor 4 (lower word)	
F+69	Axis 5 Expanded Monitor 4 (upper word)	
F+70	Axis 5 Expanded Monitor 5 (lower word)	

6-6 Operation Memory Areas



Words	Name	Function
F+71	Axis 5 Expanded Monitor 5 (upper word)	Refer to the description for axis 1. These words are not used for a two-axis or four-axis PCU.
F+72	Axis 5 Expanded Monitor 6 (lower word)	
F+73	Axis 5 Expanded Monitor 6 (upper word)	
F+74	Not used.	Do not use.
F+75	Not used.	
F+76	Not used.	
F+77	Not used.	
F+78	Not used.	
F+79	Not used.	
F+80	Axis 6 Expanded Monitor 2 (lower word)	Refer to the description for axis 1. These words are not used for a two-axis or four-axis PCU.
F+81	Axis 6 Expanded Monitor 2 (upper word)	
F+82	Axis 6 Expanded Monitor 3 (lower word)	
F+83	Axis 6 Expanded Monitor 3 (upper word)	
F+84	Axis 6 Expanded Monitor 4 (lower word)	
F+85	Axis 6 Expanded Monitor 4 (upper word)	
F+86	Axis 6 Expanded Monitor 5 (lower word)	
F+87	Axis 6 Expanded Monitor 5 (upper word)	
F+88	Axis 6 Expanded Monitor 6 (lower word)	
F+89	Axis 6 Expanded Monitor 6 (upper word)	
F+90	Not used.	Do not use.
F+91	Not used.	
F+92	Not used.	
F+93	Not used.	
F+94	Not used.	
F+95	Not used.	

Words	Name	Function
F+96	Axis 7 Expanded Monitor 2 (lower word)	Refer to the description for axis 1. These words are not used for a two-axis or four-axis PCU.
F+97	Axis 7 Expanded Monitor 2 (upper word)	
F+98	Axis 7 Expanded Monitor 3 (lower word)	
F+99	Axis 7 Expanded Monitor 3 (upper word)	
F+100	Axis 7 Expanded Monitor 4 (lower word)	
F+101	Axis 7 Expanded Monitor 4 (upper word)	
F+102	Axis 7 Expanded Monitor 5 (lower word)	
F+103	Axis 7 Expanded Monitor 5 (upper word)	
F+104	Axis 7 Expanded Monitor 6 (lower word)	
F+105	Axis 7 Expanded Monitor 6 (upper word)	
F+106	Not used.	
F+107	Not used.	
F+108	Not used.	
F+109	Not used.	
F+110	Not used.	
F+111	Not used.	
F+112	Axis 8 Expanded Monitor 2 (lower word)	Refer to the description for axis 1. These words are not used for a two-axis or four-axis PCU.
F+113	Axis 8 Expanded Monitor 2 (upper word)	
F+114	Axis 8 Expanded Monitor 3 (lower word)	
F+115	Axis 8 Expanded Monitor 3 (upper word)	
F+116	Axis 8 Expanded Monitor 4 (lower word)	
F+117	Axis 8 Expanded Monitor 4 (upper word)	
F+118	Axis 8 Expanded Monitor 5 (lower word)	
F+119	Axis 8 Expanded Monitor 5 (upper word)	
F+120	Axis 8 Expanded Monitor 6 (lower word)	
F+121	Axis 8 Expanded Monitor 6 (upper word)	

6-6 Operation Memory Areas



Words	Name	Function
F+122	Not used.	Do not use.
F+123	Not used.	
F+124	Not used.	
F+125	Not used.	
F+126	Not used.	
F+127	Not used.	
F+128	Axis 9 Expanded Monitor 2 (lower word)	Refer to the description for axis 1. These words are not used for a two-axis, four-axis, or eight-axis PCU.
F+129	Axis 9 Expanded Monitor 2 (upper word)	
F+130	Axis 9 Expanded Monitor 3 (lower word)	
F+131	Axis 9 Expanded Monitor 3 (upper word)	
F+132	Axis 9 Expanded Monitor 4 (lower word)	
F+133	Axis 9 Expanded Monitor 4 (upper word)	
F+134	Axis 9 Expanded Monitor 5 (lower word)	
F+135	Axis 9 Expanded Monitor 5 (upper word)	
F+136	Axis 9 Expanded Monitor 6 (lower word)	
F+137	Axis 9 Expanded Monitor 6 (upper word)	
F+138	Not used.	Do not use.
F+139	Not used.	
F+140	Not used.	
F+141	Not used.	
F+142	Not used.	
F+143	Not used.	

Words	Name	Function
F+144	Axis 10 Expanded Monitor 2 (lower word)	Refer to the description for axis 1. These words are not used for a two-axis, four-axis, or eight-axis PCU.
F+145	Axis 10 Expanded Monitor 2 (upper word)	
F+146	Axis 10 Expanded Monitor 3 (lower word)	
F+147	Axis 10 Expanded Monitor 3 (upper word)	
F+148	Axis 10 Expanded Monitor 4 (lower word)	
F+149	Axis 10 Expanded Monitor 4 (upper word)	
F+150	Axis 10 Expanded Monitor 5 (lower word)	
F+151	Axis 10 Expanded Monitor 5 (upper word)	
F+152	Axis 10 Expanded Monitor 6 (lower word)	
F+153	Axis 10 Expanded Monitor 6 (upper word)	
F+154	Not used.	Do not use.
F+155	Not used.	
F+156	Not used.	
F+157	Not used.	
F+158	Not used.	
F+159	Not used.	
F+160	Axis 11 Expanded Monitor 2 (lower word)	Refer to the description for axis 1. These words are not used for a two-axis, four-axis, or eight-axis PCU.
F+161	Axis 11 Expanded Monitor 2 (upper word)	
F+162	Axis 11 Expanded Monitor 3 (lower word)	
F+163	Axis 11 Expanded Monitor 3 (upper word)	
F+164	Axis 11 Expanded Monitor 4 (lower word)	
F+165	Axis 11 Expanded Monitor 4 (upper word)	
F+166	Axis 11 Expanded Monitor 5 (lower word)	
F+167	Axis 11 Expanded Monitor 5 (upper word)	
F+168	Axis 11 Expanded Monitor 6 (lower word)	
F+169	Axis 11 Expanded Monitor 6 (upper word)	

6-6 Operation Memory Areas



Words	Name	Function
F+170	Not used.	Do not use.
F+171	Not used.	
F+172	Not used.	
F+173	Not used.	
F+174	Not used.	
F+175	Not used.	
F+176	Axis 12 Expanded Monitor 2 (lower word)	Refer to the description for axis 1. These words are not used for a two-axis, four-axis, or eight-axis PCU.
F+177	Axis 12 Expanded Monitor 2 (upper word)	
F+178	Axis 12 Expanded Monitor 3 (lower word)	
F+179	Axis 12 Expanded Monitor 3 (upper word)	
F+180	Axis 12 Expanded Monitor 4 (lower word)	
F+181	Axis 12 Expanded Monitor 4 (upper word)	
F+182	Axis 12 Expanded Monitor 5 (lower word)	
F+183	Axis 12 Expanded Monitor 5 (upper word)	
F+184	Axis 12 Expanded Monitor 6 (lower word)	
F+185	Axis 12 Expanded Monitor 6 (upper word)	
F+186	Not used.	Do not use.
F+187	Not used.	
F+188	Not used.	
F+189	Not used.	
F+190	Not used.	
F+191	Not used.	

Words	Name	Function
F+192	Axis 13 Expanded Monitor 2 (lower word)	Refer to the description for axis 1. These words are not used for a two-axis, four-axis, or eight-axis PCU.
F+193	Axis 13 Expanded Monitor 2 (upper word)	
F+194	Axis 13 Expanded Monitor 3 (lower word)	
F+195	Axis 13 Expanded Monitor 3 (upper word)	
F+196	Axis 13 Expanded Monitor 4 (lower word)	
F+197	Axis 13 Expanded Monitor 4 (upper word)	
F+198	Axis 13 Expanded Monitor 5 (lower word)	
F+199	Axis 13 Expanded Monitor 5 (upper word)	
F+200	Axis 13 Expanded Monitor 6 (lower word)	
F+201	Axis 13 Expanded Monitor 6 (upper word)	
F+202	Not used.	
F+203	Not used.	
F+204	Not used.	
F+205	Not used.	
F+206	Not used.	
F+207	Not used.	
F+208	Axis 14 Expanded Monitor 2 (lower word)	Refer to the description for axis 1. These words are not used for a two-axis, four-axis, or eight-axis PCU.
F+209	Axis 14 Expanded Monitor 2 (upper word)	
F+210	Axis 14 Expanded Monitor 3 (lower word)	
F+211	Axis 14 Expanded Monitor 3 (upper word)	
F+212	Axis 14 Expanded Monitor 4 (lower word)	
F+213	Axis 14 Expanded Monitor 4 (upper word)	
F+214	Axis 14 Expanded Monitor 5 (lower word)	
F+215	Axis 14 Expanded Monitor 5 (upper word)	
F+216	Axis 14 Expanded Monitor 6 (lower word)	
F+217	Axis 14 Expanded Monitor 6 (upper word)	

6-6 Operation Memory Areas



Words	Name	Function
F+218	Not used.	Do not use.
F+219	Not used.	
F+220	Not used.	
F+221	Not used.	
F+222	Not used.	
F+223	Not used.	
F+224	Axis 15 Expanded Monitor 2 (lower word)	Refer to the description for axis 1. These words are not used for a two-axis, four-axis, or eight-axis PCU.
F+225	Axis 15 Expanded Monitor 2 (upper word)	
F+226	Axis 15 Expanded Monitor 3 (lower word)	
F+227	Axis 15 Expanded Monitor 3 (upper word)	
F+228	Axis 15 Expanded Monitor 4 (lower word)	
F+229	Axis 15 Expanded Monitor 4 (upper word)	
F+230	Axis 15 Expanded Monitor 5 (lower word)	
F+231	Axis 15 Expanded Monitor 5 (upper word)	
F+232	Axis 15 Expanded Monitor 6 (lower word)	
F+233	Axis 15 Expanded Monitor 6 (upper word)	
F+234	Not used.	Do not use.
F+235	Not used.	
F+236	Not used.	
F+237	Not used.	
F+238	Not used.	
F+239	Not used.	

Words	Name	Function
F+240	Axis 16 Expanded Monitor 2 (lower word)	Refer to the description for axis 1. These words are not used for a two-axis, four-axis, or eight-axis PCU.
F+241	Axis 16 Expanded Monitor 2 (upper word)	
F+242	Axis 16 Expanded Monitor 3 (lower word)	
F+243	Axis 16 Expanded Monitor 3 (upper word)	
F+244	Axis 16 Expanded Monitor 4 (lower word)	
F+245	Axis 16 Expanded Monitor 4 (upper word)	
F+246	Axis 16 Expanded Monitor 5 (lower word)	
F+247	Axis 16 Expanded Monitor 5 (upper word)	
F+248	Axis 16 Expanded Monitor 6 (lower word)	
F+249	Axis 16 Expanded Monitor 6 (upper word)	
F+250	Not used.	Do not use.
F+251	Not used.	
F+252	Not used.	
F+253	Not used.	
F+254	Not used.	
F+255	Not used.	



Remote I/O Output Memory Area

The Remote I/O Output Memory Area is used for the remote I/O master function and is allocated to the Output Memory Areas of the remote I/O slaves with node addresses 17 to 80. For details on setting the Remote I/O Output Memory Area, refer to *Remote I/O Output Memory Area Selection* on page 6-22. The outputs of remote I/O slaves are allocated according to the network configuration information.

The default first word of the Remote I/O Output Memory Area is CIO 3800.

The following table lists the allocations when you set the First Word of the Remote I/O Output Memory Area parameter to word "G."



Precautions for Correct Use

This is applicable only when using CJ1W-NC482/882/F82 PCUs only. The setting is not applicable for other Units.

Word	Name	Function
G	Remote I/O Output Memory Area	Output memory areas are allocated to connected remote I/O slaves. For details on the output bit allocations, refer to <i>Allocations of Remote I/O Memory Areas</i> on page 6-5.
G+1		
G+2		
:		

Remote I/O Input Memory Area

The Remote I/O Input Memory Area is used for the remote I/O master function and is allocated to the input memory areas of the remote I/O slaves with node addresses 17 to 80.

For details on setting the Remote I/O Input Memory Area, refer to *Remote I/O Input Memory Area Selection* on page 6-23. The inputs of remote I/O slaves are allocated according to the network configuration information.

The default first word of the Remote I/O Input Memory Area is CIO 3900.

The following table lists the allocations when you set the First Word of the Remote I/O Input Memory Area parameter to word "H."



Precautions for Correct Use

This is applicable only when using CJ1W-NC482/882/F82 PCUs only. The setting is not applicable for other Units.

Word	Name	Function
H	Remote I/O Input Memory Area	Input memory areas are allocated to connected remote I/O slaves. For details on the input bit allocations, refer to <i>Allocations of Remote I/O Memory Areas</i> on page 6-5.
H+1		
H+2		
:		

Remote I/O Communications Status Memory Area

For details on setting the Remote I/O Communications Status Memory Area, refer to *Remote I/O Communications Status Memory Area Selection* on page 6-24.

The default first word of the Remote I/O Communications Status Memory Area is CIO 3980.

The following table lists the allocations when you set the First Word of the Remote I/O Communications Status Memory Area parameter to word “J.”



Precautions for Correct Use

These allocation are applicable only when using CJ1W-NC482/882/F82 PCUs. The setting is not applicable for other Units.

Words	Name	Bit	Bit name	Function
J	Registered Remote I/O Slave Table 1	0	Node 17 Registered Flag	These flags turn ON when the corresponding nodes exist in the network configuration information.
		1	Node 18 Registered Flag	
		2	Node 19 Registered Flag	
		3	Node 20 Registered Flag	
		4	Node 21 Registered Flag	
		5	Node 22 Registered Flag	
		6	Node 23 Registered Flag	
		7	Node 24 Registered Flag	
		8	Node 25 Registered Flag	
		9	Node 26 Registered Flag	
		10	Node 27 Registered Flag	
		11	Node 28 Registered Flag	
		12	Node 29 Registered Flag	
		13	Node 30 Registered Flag	
		14	Node 31 Registered Flag	
		15	Node 32 Registered Flag	

Words	Name	Bit	Bit name	Function
J+1	Registered Remote I/O Slave Table 2	0	Node 33 Registered Flag	These flags turn ON when the corresponding nodes exist in the network configuration information.
		1	Node 34 Registered Flag	
		2	Node 35 Registered Flag	
		3	Node 36 Registered Flag	
		4	Node 37 Registered Flag	
		5	Node 38 Registered Flag	
		6	Node 39 Registered Flag	
		7	Node 40 Registered Flag	
		8	Node 41 Registered Flag	
		9	Node 42 Registered Flag	
		10	Node 43 Registered Flag	
		11	Node 44 Registered Flag	
		12	Node 45 Registered Flag	
		13	Node 46 Registered Flag	
		14	Node 47 Registered Flag	
15	Node 48 Registered Flag			
J+2	Registered Remote I/O Slave Table 3	0	Node 49 Registered Flag	These flags turn ON when the corresponding nodes exist in the network configuration information.
		1	Node 50 Registered Flag	
		2	Node 51 Registered Flag	
		3	Node 52 Registered Flag	
		4	Node 53 Registered Flag	
		5	Node 54 Registered Flag	
		6	Node 55 Registered Flag	
		7	Node 56 Registered Flag	

6-6 Operation Memory Areas



Words	Name	Bit	Bit name	Function
J+2 (continued)	Registered Remote I/O Slave Table 3	8	Node 57 Registered Flag	These flags turn ON when the corresponding nodes exist in the network configuration information.
		9	Node 58 Registered Flag	
		10	Node 59 Registered Flag	
		11	Node 60 Registered Flag	
		12	Node 61 Registered Flag	
		13	Node 62 Registered Flag	
		14	Node 63 Registered Flag	
		15	Node 64 Registered Flag	
J+3	Registered Remote I/O Slave Table 4	0	Node 65 Registered Flag	These flags turn ON when the corresponding nodes exist in the network configuration information.
		1	Node 66 Registered Flag	
		2	Node 67 Registered Flag	
		3	Node 68 Registered Flag	
		4	Node 69 Registered Flag	
		5	Node 70 Registered Flag	
		6	Node 71 Registered Flag	
		7	Node 72 Registered Flag	
		8	Node 73 Registered Flag	
		9	Node 74 Registered Flag	
		10	Node 75 Registered Flag	
		11	Node 76 Registered Flag	
		12	Node 77 Registered Flag	
		13	Node 78 Registered Flag	
		14	Node 79 Registered Flag	
15	Node 80 Registered Flag			

Words	Name	Bit	Bit name	Function
J+4	Remote I/O Network Participation Table 1	0	Node 17 Network Participation Flag	These flags turn ON when the corresponding nodes are detected in the network.
		1	Node 18 Network Participation Flag	
		2	Node 19 Network Participation Flag	
		3	Node 20 Network Participation Flag	
		4	Node 21 Network Participation Flag	
		5	Node 22 Network Participation Flag	
		6	Node 23 Network Participation Flag	
		7	Node 24 Network Participation Flag	
		8	Node 25 Network Participation Flag	
		9	Node 26 Network Participation Flag	
		10	Node 27 Network Participation Flag	
		11	Node 28 Network Participation Flag	
		12	Node 29 Network Participation Flag	
		13	Node 30 Network Participation Flag	
		14	Node 31 Network Participation Flag	
15	Node 32 Network Participation Flag			
J+5	Remote I/O Network Participation Table 2	0	Node 33 Network Participation Flag	These flags turn ON when the corresponding nodes are detected in the network.
		1	Node 34 Network Participation Flag	
		2	Node 35 Network Participation Flag	
		3	Node 36 Network Participation Flag	
		4	Node 37 Network Participation Flag	
		5	Node 38 Network Participation Flag	
		6	Node 39 Network Participation Flag	
		7	Node 40 Network Participation Flag	

6-6 Operation Memory Areas

6

Setting Data

Words	Name	Bit	Bit name	Function
J+5 (continued)	Remote I/O Network Participa- tion Table 2	8	Node 41 Network Participation Flag	These flags turn ON when the corresponding nodes are detected in the network.
		9	Node 42 Network Participation Flag	
		10	Node 43 Network Participation Flag	
		11	Node 44 Network Participation Flag	
		12	Node 45 Network Participation Flag	
		13	Node 46 Network Participation Flag	
		14	Node 47 Network Participation Flag	
		15	Node 48 Network Participation Flag	
J+6	Remote I/O Network Participa- tion Table 3	0	Node 49 Network Participation Flag	These flags turn ON when the corresponding nodes are detected in the network.
		1	Node 50 Network Participation Flag	
		2	Node 51 Network Participation Flag	
		3	Node 52 Network Participation Flag	
		4	Node 53 Network Participation Flag	
		5	Node 54 Network Participation Flag	
		6	Node 55 Network Participation Flag	
		7	Node 56 Network Participation Flag	
		8	Node 57 Network Participation Flag	
		9	Node 58 Network Participation Flag	
		10	Node 59 Network Participation Flag	
		11	Node 60 Network Participation Flag	
		12	Node 61 Network Participation Flag	
		13	Node 62 Network Participation Flag	
		14	Node 63 Network Participation Flag	
15	Node 64 Network Participation Flag			

Words	Name	Bit	Bit name	Function
J+7	Remote I/O Network Participation Table 4	0	Node 65 Network Participation Flag	These flags turn ON when the corresponding nodes are detected in the network.
		1	Node 66 Network Participation Flag	
		2	Node 67 Network Participation Flag	
		3	Node 68 Network Participation Flag	
		4	Node 69 Network Participation Flag	
		5	Node 70 Network Participation Flag	
		6	Node 71 Network Participation Flag	
		7	Node 72 Network Participation Flag	
		8	Node 73 Network Participation Flag	
		9	Node 74 Network Participation Flag	
		10	Node 75 Network Participation Flag	
		11	Node 76 Network Participation Flag	
		12	Node 77 Network Participation Flag	
		13	Node 78 Network Participation Flag	
		14	Node 79 Network Participation Flag	
15	Node 80 Network Participation Flag			
J+8	Remote I/O Slave Message Communications Enabled Table 1	0	Node 17 Message Communications Enabled Flag	These flags turn ON when message communications are enabled for the corresponding nodes.
		1	Node 18 Message Communications Enabled Flag	
		2	Node 19 Message Communications Enabled Flag	
		3	Node 20 Message Communications Enabled Flag	
		4	Node 21 Message Communications Enabled Flag	
		5	Node 22 Message Communications Enabled Flag	

6-6 Operation Memory Areas



Words	Name	Bit	Bit name	Function
J+8 (continued)	Remote I/O Slave Message Communications Enabled Table 1	6	Node 23 Message Communications Enabled Flag	These flags turn ON when message communications are enabled for the corresponding nodes.
		7	Node 24 Message Communications Enabled Flag	
		8	Node 25 Message Communications Enabled Flag	
		9	Node 26 Message Communications Enabled Flag	
		10	Node 27 Message Communications Enabled Flag	
		11	Node 28 Message Communications Enabled Flag	
		12	Node 29 Message Communications Enabled Flag	
		13	Node 30 Message Communications Enabled Flag	
		14	Node 31 Message Communications Enabled Flag	
J+9	Remote I/O Slave Message Communications Enabled Table 2	0	Node 33 Message Communications Enabled Flag	These flags turn ON when message communications are enabled for the corresponding nodes.
		1	Node 34 Message Communications Enabled Flag	
		2	Node 35 Message Communications Enabled Flag	
		3	Node 36 Message Communications Enabled Flag	
		4	Node 37 Message Communications Enabled Flag	
		5	Node 38 Message Communications Enabled Flag	
		6	Node 39 Message Communications Enabled Flag	

Words	Name	Bit	Bit name	Function
J+9 (continued)	Remote I/O Slave Message Communications Enabled Table 2	7	Node 40 Message Communications Enabled Flag	These flags turn ON when message communications are enabled for the corresponding nodes.
		8	Node 41 Message Communications Enabled Flag	
		9	Node 42 Message Communications Enabled Flag	
		10	Node 43 Message Communications Enabled Flag	
		11	Node 44 Message Communications Enabled Flag	
		12	Node 45 Message Communications Enabled Flag	
		13	Node 46 Message Communications Enabled Flag	
		14	Node 47 Message Communications Enabled Flag	
J+10	Remote I/O Slave Message Communications Enabled Table 3	0	Node 49 Message Communications Enabled Flag	These flags turn ON when message communications are enabled for the corresponding nodes.
		1	Node 50 Message Communications Enabled Flag	
		2	Node 51 Message Communications Enabled Flag	
		3	Node 52 Message Communications Enabled Flag	
		4	Node 53 Message Communications Enabled Flag	
		5	Node 54 Message Communications Enabled Flag	
		6	Node 55 Message Communications Enabled Flag	
		7	Node 56 Message Communications Enabled Flag	

6-6 Operation Memory Areas



Setting Data

Words	Name	Bit	Bit name	Function
J+10 (continued)	Remote I/O Slave Message Communications Enabled Table 3	8	Node 57 Message Communications Enabled Flag	These flags turn ON when message communications are enabled for the corresponding nodes.
		9	Node 58 Message Communications Enabled Flag	
		10	Node 59 Message Communications Enabled Flag	
		11	Node 60 Message Communications Enabled Flag	
		12	Node 61 Message Communications Enabled Flag	
		13	Node 62 Message Communications Enabled Flag	
		14	Node 63 Message Communications Enabled Flag	
		15	Node 64 Message Communications Enabled Flag	
J+11	Remote I/O Slave Message Communications Enabled Table 4	0	Node 65 Message Communications Enabled Flag	These flags turn ON when message communications are enabled for the corresponding nodes.
		1	Node 66 Message Communications Enabled Flag	
		2	Node 67 Message Communications Enabled Flag	
		3	Node 68 Message Communications Enabled Flag	
		4	Node 69 Message Communications Enabled Flag	
		5	Node 70 Message Communications Enabled Flag	
		6	Node 71 Message Communications Enabled Flag	
		7	Node 72 Message Communications Enabled Flag	

Words	Name	Bit	Bit name	Function
J+11 (continued)	Remote I/O Slave Message Communications Enabled Table 4	8	Node 73 Message Communications Enabled Flag	These flags turn ON when message commu- nications are enabled for the corresponding nodes.
		9	Node 74 Message Communications Enabled Flag	
		10	Node 75 Message Communications Enabled Flag	
		11	Node 76 Message Communications Enabled Flag	
		12	Node 77 Message Communications Enabled Flag	
		13	Node 78 Message Communications Enabled Flag	
		14	Node 79 Message Communications Enabled Flag	
		15	Node 80 Message Communications Enabled Flag	
J+12	Remote I/O Normal Slave Table 1	0	Node 17 Normal Communications Flag	These flags turn ON when process data com- munications are being performed for the cor- responding nodes.
		1	Node 18 Normal Communications Flag	
		2	Node 19 Normal Communications Flag	
		3	Node 20 Normal Communications Flag	
		4	Node 21 Normal Communications Flag	
		5	Node 22 Normal Communications Flag	
		6	Node 23 Normal Communications Flag	
		7	Node 24 Normal Communications Flag	
		8	Node 25 Normal Communications Flag	

6-6 Operation Memory Areas



Setting Data

Words	Name	Bit	Bit name	Function
J+12 (continued)	Remote I/O Normal Slave Table 1	9	Node 26 Normal Communications Flag	These flags turn ON when process data communications are being performed for the corresponding nodes.
		10	Node 27 Normal Communications Flag	
		11	Node 28 Normal Communications Flag	
		12	Node 29 Normal Communications Flag	
		13	Node 30 Normal Communications Flag	
		14	Node 31 Normal Communications Flag	
		15	Node 32 Normal Communications Flag	
J+13	Remote I/O Normal Slave Table 2	0	Node 33 Normal Communications Flag	These flags turn ON when process data communications are being performed for the corresponding nodes.
		1	Node 34 Normal Communications Flag	
		2	Node 35 Normal Communications Flag	
		3	Node 36 Normal Communications Flag	
		4	Node 37 Normal Communications Flag	
		5	Node 38 Normal Communications Flag	
		6	Node 39 Normal Communications Flag	
		7	Node 40 Normal Communications Flag	
		8	Node 41 Normal Communications Flag	
		9	Node 42 Normal Communications Flag	

Words	Name	Bit	Bit name	Function
J+13 (continued)	Remote I/O Normal Slave Table 2	10	Node 43 Normal Communications Flag	These flags turn ON when process data com- munications are being performed for the cor- responding nodes.
		11	Node 44 Normal Communications Flag	
		12	Node 45 Normal Communications Flag	
		13	Node 46 Normal Communications Flag	
		14	Node 47 Normal Communications Flag	
		15	Node 48 Normal Communications Flag	
J+14	Remote I/O Normal Slave Table 3	0	Node 49 Normal Communications Flag	These flags turn ON when process data com- munications are being performed for the cor- responding nodes.
		1	Node 50 Normal Communications Flag	
		2	Node 51 Normal Communications Flag	
		3	Node 52 Normal Communications Flag	
		4	Node 53 Normal Communications Flag	
		5	Node 54 Normal Communications Flag	
		6	Node 55 Normal Communications Flag	
		7	Node 56 Normal Communications Flag	
		8	Node 57 Normal Communications Flag	
		9	Node 58 Normal Communications Flag	
		10	Node 59 Normal Communications Flag	

6-6 Operation Memory Areas



Words	Name	Bit	Bit name	Function
J+14 (continued)	Remote I/O Normal Slave Table 3	11	Node 60 Normal Communications Flag	These flags turn ON when process data communications are being performed for the corresponding nodes.
		12	Node 61 Normal Communications Flag	
		13	Node 62 Normal Communications Flag	
		14	Node 63 Normal Communications Flag	
		15	Node 64 Normal Communications Flag	
J+15	Remote I/O Normal Slave Table 4	0	Node 65 Normal Communications Flag	These flags turn ON when process data communications are being performed for the corresponding nodes.
		1	Node 66 Normal Communications Flag	
		2	Node 67 Normal Communications Flag	
		3	Node 68 Normal Communications Flag	
		4	Node 69 Normal Communications Flag	
		5	Node 70 Normal Communications Flag	
		6	Node 71 Normal Communications Flag	
		7	Node 72 Normal Communications Flag	
		8	Node 73 Normal Communications Flag	
		9	Node 74 Normal Communications Flag	
		10	Node 75 Normal Communications Flag	
		11	Node 76 Normal Communications Flag	

Words	Name	Bit	Bit name	Function
J+15 (continued)	Remote I/O Normal Slave Table 4	12	Node 77 Normal Communications Flag	These flags turn ON when process data communications are being performed for the corresponding nodes.
		13	Node 78 Normal Communications Flag	
		14	Node 79 Normal Communications Flag	
		15	Node 80 Normal Communications Flag	
J+16	Remote I/O Error Slave Table 1	0	Node 17 Communi- cations Error Flag	<p>These flags turn ON when any of the following communications errors occur in the corresponding nodes.</p> <ul style="list-style-type: none"> ◆ Slave Initialization Error Flag ◆ Slave Node Address Duplicated Flag ◆ Slave AL Status Error Flag ◆ Network Configuration Verification Error Flag ◆ Process Data Communications Error Flag
		1	Node 18 Communi- cations Error Flag	
		2	Node 19 Communi- cations Error Flag	
		3	Node 20 Communi- cations Error Flag	
		4	Node 21 Communi- cations Error Flag	
		5	Node 22 Communi- cations Error Flag	
		6	Node 23 Communi- cations Error Flag	
		7	Node 24 Communi- cations Error Flag	
		8	Node 25 Communi- cations Error Flag	
		9	Node 26 Communi- cations Error Flag	
		10	Node 27 Communi- cations Error Flag	
		11	Node 28 Communi- cations Error Flag	
		12	Node 29 Communi- cations Error Flag	
		13	Node 30 Communi- cations Error Flag	
		14	Node 31 Communi- cations Error Flag	
15	Node 32 Communi- cations Error Flag			

6-6 Operation Memory Areas

Words	Name	Bit	Bit name	Function
J+17	Remote I/O Error Slave Table 2	0	Node 33 Communications Error Flag	<p>These flags turn ON when any of the following communications errors occur in the corresponding nodes.</p> <ul style="list-style-type: none"> ◆ Slave Initialization Error Flag ◆ Slave Node Address Duplicated Flag ◆ Slave AL Status Error Flag ◆ Network Configuration Verification Error Flag ◆ Process Data Communications Error Flag
		1	Node 34 Communications Error Flag	
		2	Node 35 Communications Error Flag	
		3	Node 36 Communications Error Flag	
		4	Node 37 Communications Error Flag	
		5	Node 38 Communications Error Flag	
		6	Node 39 Communications Error Flag	
		7	Node 40 Communications Error Flag	
		8	Node 41 Communications Error Flag	
		9	Node 42 Communications Error Flag	
		10	Node 43 Communications Error Flag	
		11	Node 44 Communications Error Flag	
		12	Node 45 Communications Error Flag	
		13	Node 46 Communications Error Flag	
		14	Node 47 Communications Error Flag	
		15	Node 48 Communications Error Flag	
J+18	Remote I/O Error Slave Table 3	0	Node 49 Communications Error Flag	<p>These flags turn ON when any of the following communications errors occur in the corresponding nodes.</p> <ul style="list-style-type: none"> ◆ Slave Initialization Error Flag ◆ Slave Node Address Duplicated Flag ◆ Slave AL Status Error Flag ◆ Network Configuration Verification Error Flag ◆ Process Data Communications Error Flag
		1	Node 50 Communications Error Flag	
		2	Node 51 Communications Error Flag	
		3	Node 52 Communications Error Flag	
		4	Node 53 Communications Error Flag	
		5	Node 54 Communications Error Flag	
		6	Node 55 Communications Error Flag	
		7	Node 56 Communications Error Flag	

Words	Name	Bit	Bit name	Function
J+18 (continued)	Remote I/O Error Slave Table 3	8	Node 57 Communi- cations Error Flag	These flags turn ON when any of the following communications errors occur in the corre- sponding nodes. <ul style="list-style-type: none"> ◆ Slave Initialization Error Flag ◆ Slave Node Address Duplicated Flag ◆ Slave AL Status Error Flag ◆ Network Configuration Verification Error Flag ◆ Process Data Communications Error Flag
		9	Node 58 Communi- cations Error Flag	
		10	Node 59 Communi- cations Error Flag	
		11	Node 60 Communi- cations Error Flag	
		12	Node 61 Communi- cations Error Flag	
		13	Node 62 Communi- cations Error Flag	
		14	Node 63 Communi- cations Error Flag	
		15	Node 64 Communi- cations Error Flag	
J+19	Remote I/O Error Slave Table 4	0	Node 65 Communi- cations Error Flag	These flags turn ON when any of the following communications errors occur in the corre- sponding nodes. <ul style="list-style-type: none"> ◆ Slave Initialization Error Flag ◆ Slave Node Address Duplicated Flag ◆ Slave AL Status Error Flag ◆ Network Configuration Verification Error Flag ◆ Process Data Communications Error Flag
		1	Node 66 Communi- cations Error Flag	
		2	Node 67 Communi- cations Error Flag	
		3	Node 68 Communi- cations Error Flag	
		4	Node 69 Communi- cations Error Flag	
		5	Node 70 Communi- cations Error Flag	
		6	Node 71 Communi- cations Error Flag	
		7	Node 72 Communi- cations Error Flag	
		8	Node 73 Communi- cations Error Flag	
		9	Node 74 Communi- cations Error Flag	
		10	Node 75 Communi- cations Error Flag	
		11	Node 76 Communi- cations Error Flag	
		12	Node 77 Communi- cations Error Flag	
		13	Node 78 Communi- cations Error Flag	
		14	Node 79 Communi- cations Error Flag	
		15	Node 80 Communi- cations Error Flag	

6-7 Memory Operation Data

Memory operation data sets the operation sequence, position, speed, acceleration/ deceleration time and other items that are related to memory operation.

Memory operation refers to an operation where you set memory operation data and memory operation condition data in the PCU beforehand, and perform positioning control and speed control based on commands from the PLC.

The PCU provides four tasks. You can register up to 500 sequence per task.

For details on memory operation, refer to *Section 8 Memory Operation*.

Memory Operation Data List

Memory operation data is continuously updated.

Also note that once you set data, it is used as valid data at the start of memory operation.



Precautions for Correct Use

- ♦ As for the PCU address for transfer, the applicable address changes depending on the command. For details, refer to *Command* on page 8-25 and *Data Addresses* on page 9-4.

Each sequence includes the following data. However, you do not need to set all of the data depending on the data attributes. For details, refer to *Details of Memory Operation Data* on page 6-152.

Data name	Function	Setting range	Unit	Default value
Configuration Axis 1 Command Position	Set the command position for configuration axis 1.	-2,147,483,648 to 2,147,483,647	Command units	0
Configuration Axis 2 Command Position	Set the command position for configuration axis 2.	-2,147,483,648 to 2,147,483,647	Command units	0
Configuration Axis 3 Command Position	Set the command position for configuration axis 3.	-2,147,483,648 to 2,147,483,647	Command units	0
Configuration Axis 4 Command Position	Set the command position for configuration axis 4.	-2,147,483,648 to 2,147,483,647	Command units	0

Data name	Function	Setting range	Unit	Default value
Command	0000 hex: No sequence data 8### hex: NOP (Treated as a comment.) Sequence Commands 0001 hex: JUMP 0002 hex: FOR 0003 hex: NEXT 0004 hex: PSET 0005 hex: PRSET 004F hex: END Operation Commands 0800 hex: Positioning 0801 hex: Linear interpolation 0802 hex: Clockwise circular interpolation 0803 hex: Counterclockwise circular interpolation 081E hex: Speed control 081F hex: Interrupt feeding for positioning 0820 hex: Interrupt feeding for speed control			0
Jump/Repeat Condition	Set the memory operation condition data number for JUMP and FOR. 0: Execute unconditionally 1 to 100: Memory operation condition data number	0 to 100	–	0
Jump Destination Sequence Number	Set the sequence number to jump to.	1 to 500	–	0
Repeat Loop Number	Set a number to pair the FOR and NEXT commands.	0 to 49	–	0
Output Signal	Specify the destination of the forced output. 0000 hex: No output ##03 hex: Forward torque limit output ##04 hex: Reverse torque limit output ##: 01 to 04 (Indicate configuration axes, 01: Configuration axis 1, 02: Configuration axis 2, 03: Configuration axis 3, 04: Configuration axis 4) 8000 to 800F hex: Memory Operation Auxiliary Area (8,000 to 800F hex correspond to bits 00 to 15, respectively.)			0
Sequence Start Condition	Set the start condition. 0: No start condition 1 to 100: Memory operation condition data number	0 to 100	–	0
Sequence Skip Condition	Set the stop/skip condition. 0: No stop/skip condition 1 to 100: Memory operation condition data number	0 to 100	–	0

6-7 Memory Operation Data

Data name	Function	Setting range	Unit	Default value
End Pattern	Set the operation end pattern. 0: Individual 1: Automatic 2: Continuous 1 (Until the next sequence speed) 3: Continuous 2 (Acceleration/deceleration starts at the next sequence) 4: Continuous 3 (Pass: Overlap deceleration for the present sequence and acceleration for the next sequence)	0 to 4	—	0
Dwell Timer	If the end pattern is set to Individual or Automatic, set the dwell time. 0: No dwell time 1 to 1000: Dwell time	0 to 1,000	10ms	0
Positioning Completed Input Monitor Valid	Select the positioning completed operation to use when an axis stops. 0: Do not wait for the completion of positioning 1: Wait for the completion of positioning	0 to 1	—	0
M Code	Set the M code for after positioning has been completed. 0: No M code 1 to 499: M codes that wait to be reset 500 to 999: M codes that do not wait to be reset	0 to 999	—	0
Axis Specification	Set the axes to start. Bit 00: Configuration axis 1 Bit 01: Configuration axis 2 Bit 02: Configuration axis 3 Bit 03: Configuration axis 4 A start command is sent when each bit turns ON.	0 to F	—	0
Circular Interpolation Method	Select the specification method for circular interpolation. 0: Specify the circular center 1: Specify the radius 2: Specify a passing point	0 to 2	—	0
Position Specification	Select whether to use a relative position or absolute position for the command position. Turn OFF a bit to indicate an absolute position. Bit 00: Configuration axis 1 Bit 01: Configuration axis 2 Bit 02: Configuration axis 3 Bit 03: Configuration axis 4	0 to F	—	0
Interpolation Speed ^{*1}	Set the interpolation speed.	1 to 2,147,483,647	Command units/s	0
Interpolation Acceleration Time	Set the interpolation acceleration time.	0 to 250,000	ms	0

Data name	Function	Setting range	Unit	Default value
Interpolation Deceleration Time	Set the interpolation deceleration time.	0 to 250,000	ms	0
Interpolation Starting Speed*1	Set the interpolation starting speed.	0 to 2,147,483,647	Command units/s	0
Interpolation Acceleration/Deceleration Curve Selection	Select the curve for interpolation acceleration/deceleration. 0: Trapezoid, 1: S-curve (tertiary curve)	0 to 1	–	0
Interpolation Acceleration/Deceleration Time Selection	Select the specification method for the interpolation acceleration/deceleration time. 0: Time from starting speed to maximum speed of each axis (constant acceleration/deceleration rate) 1: Time from present speed to target speed of each axis (constant acceleration/ deceleration time)	0 to 1	–	0
Configuration Axis 1 Circular Center/ Passing Point Position	Set the center position of the arc if the center point was selected for the Circular Interpolation Method. Set the passing point position on the arc if the passing point selected for the Circular Interpolation Method.	-2,147,483,648 to 2,147,483,647	Command units	0
Configuration Axis 2 Circular Center/ Passing Point Position		-2,147,483,648 to 2,147,483,647	Command units	0
Configuration Axis 3 Circular Center/ Passing Point Position		-2,147,483,648 to 2,147,483,647	Command units	0
Configuration Axis 4 Circular Center/ Passing Point Position		-2,147,483,648 to 2,147,483,647	Command units	0
Circular Radius	Set the circular radius if the radius was selected for the Circular Interpolation Method.	-2,147,483,648 to 2,147,483,647	Command units	0
Configuration Axis 1 Rotation Axis Direction	If you select a rotation axis in the applicable axis parameter, select the operating direction for positioning (PTP) for an absolute movement designation. 0: Shortest route 1: Forward 2: Reverse 3: Not specified	0 to 3	–	0
Configuration Axis 2 Rotation Axis Direction		0 to 3	–	0
Configuration Axis 3 Rotation Axis Direction		0 to 3	–	0
Configuration Axis 4 Rotation Axis Direction		0 to 3	–	0

6-7 Memory Operation Data

Data name	Function	Setting range	Unit	Default value
Configuration Axis 1 Command Speed* ²	Set the target speed of each axis in positioning operation (PTP) and speed control. The command range is 1 to 2,147,483,647 for positioning, and -2,147,483,648 to 2,147,483,647 for speed control.	-2,147,483,648 to 2,147,483,647	Command units/s	0
Configuration Axis 2 Command Speed* ²		-2,147,483,648 to 2,147,483,647	Command units/s	0
Configuration Axis 3 Command Speed* ²		-2,147,483,648 to 2,147,483,647	Command units/s	0
Configuration Axis 4 Command Speed* ²		-2,147,483,648 to 2,147,483,647	Command units/s	0
Configuration Axis 1 Acceleration Time	Set the acceleration time in positioning operation (PTP) and speed control.	0 to 250,000	ms	0
Configuration Axis 2 Acceleration Time		0 to 250,000	ms	0
Configuration Axis 3 Acceleration Time		0 to 250,000	ms	0
Configuration Axis 4 Acceleration Time		0 to 250,000	ms	0
Configuration Axis 1 Deceleration Time	Set the deceleration time in positioning operation (PTP) and speed control.	0 to 250,000	ms	0
Configuration Axis 2 Deceleration Time		0 to 250,000	ms	0
Configuration Axis 3 Deceleration Time		0 to 250,000	ms	0
Configuration Axis 4 Deceleration Time		0 to 250,000	ms	0
Interpolation Speed Specification Method	Select the Interpolation Speed Specification Method for linear interpolation. 0: Specify the interpolation path speed. 1: Specify the maximum speed.	0 to 1	—	0
Error Enable for Undetected Interrupt Input	Select whether to output an error when an interrupt input is not received before positioning is completed during interrupt feeding for position control. 0: Without error detection 1: With error detection	0 to 1	—	0
Interrupt Feeding Amount	Set the amount of movement in interrupt feeding.	-2,147,483,648 to 2,147,483,647	Command units	0

*1. The setting is made in command units/s. The speed set in the Maximum Speed parameter is the upper limit for each axis during interpolation.

*2. The setting is made in command units/s, but if the setting is converted to pulses, 1 to 104,857,600 pps cannot be exceeded for positioning and -104,857,600 to 104,857,600 cannot be exceeded for speed control.

Details of Memory Operation Data

This section describes each memory operation data.
For the specific setting method for memory operation, refer to *Section 8 Memory Operation*.

Configuration Axis 1 to 4 Command Positions

Position data is enabled only for axes that are allocated in the Configuration Axes memory operation parameter.

For information on the Configuration Axes parameter, refer to *Configuration Axes* on page 6-72 and *Configuration Axes for Memory Operation* on page 8-2.

Command

The command determines the attributes of each sequence.

There are two types of command data: data with sequence attributes and data with operation attributes.

For details, refer to *Command* on page 8-25.

Sequence Commands

- JUMP: JUMP is used for sequence data for a JUMP command.
The position data number jumps to the one that you specified unconditionally or conditionally.
- FOR: Set for sequence data for the FOR instruction.
Repeats the steps until NEXT unconditionally or conditionally. (Up to 50 nesting levels are possible.)
- NEXT: Set for sequence data for the NEXT instruction.
Indicates the end of the repetition range for FOR.
- PSET: Set for sequence data that forcibly turns ON a PCU output.
Set Output Signal to the output that you want to forcibly turn ON. This data is held during memory operation.
- PRSET: Set for sequence data that forcibly turns OFF a PCU output.
Set Output Signal to the output that you want to forcibly turn OFF. This data is held during memory operation.
- END: Set for sequence data for END of memory operation.
When you execute END, the executing sequence number changes to the sequence number that was effective when Sequence Number Enable Bit was turned ON.

Operation Commands

Positioning operation (PTP):	Set for sequence data for positioning.
Linear interpolation operation:	Set for sequence data for linear interpolation.
Clockwise circular interpolation operation:	Set for sequence data for clockwise circular interpolation.
Counterclockwise circular interpolation operation:	Set for sequence data for counterclockwise circular interpolation.
Speed control:	Set for sequence data for speed control.
Interrupt feeding during positioning:	Set for sequence data for interrupt feeding for positioning.
Interrupt feeding during speed control:	Set for sequence data for interrupt feeding for speed control.

Jump/Repeat Condition

Set the memory operation condition data number for JUMP and FOR instructions. If you set 0, these instructions are executed unconditionally.

For information on the memory operation condition data, refer to *6-8 Memory Operation Condition Data* on page 6-163.

Jump Destination Sequence Number

Specify the sequence data number for the destination of a JUMP instruction.

Repeat Loop Number

Set a number to pair the FOR and NEXT commands.

A repeat loop is formed between the FOR and NEXT commands with the same repeat loop number.

If you duplicate repeat loop numbers, an error occurs.

Output Signal

Specify the output destination of a forced output (PSET or PRSET).

Sequence Start Condition

A sequence starts when the set Sequence Start Condition is satisfied.

If you set 0 (No Start Condition), the sequence starts immediately.

Sequence Skip Condition

The sequence skip condition is enabled after the start of a sequence until the start of the next sequence. Stopping or skipping occurs when the specified Sequence Skipping Condition is satisfied during sequence execution.

For skipping, the program stops the applicable sequence operation and switches to the next sequence according to the end pattern.

If you do not want sequences to stop or skip, set this parameter to 0 (No Stopping or Skipping).

End Pattern

An operation end pattern is set.



Precautions for Correct Use

- ◆ Specifying continuous 1 to 3 is enabled only when the sequence is an interpolation operation. If continuous 1 to continuous 3 is specified for operations other than interpolation, the operation will be the same as for an automatic end pattern.
- ◆ To implement continuous operation, you must set the command to Linear Interpolation or Circular Interpolation, and you must not set a sequence start condition for the next sequence.

The operations performed for each end pattern are described below.

Individual:

When the Memory Operation Start Bit in the Memory Operation Command Memory Area turns ON, the specified sequence is executed, the Executing Sequence Number is updated, and then the operation ends.

The sequence number is updated to the next number, so the next sequence is executed when the Memory Operation Start Bit is turned ON again.

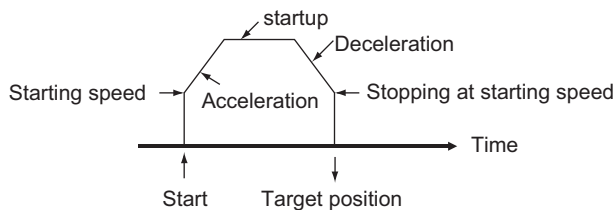

Automatic:

When the Memory Operation Start Bit in the Memory Operation Command Memory Area turns ON, the specified sequence is executed. When the condition for the next sequence number is satisfied, also the next sequence is executed automatically.

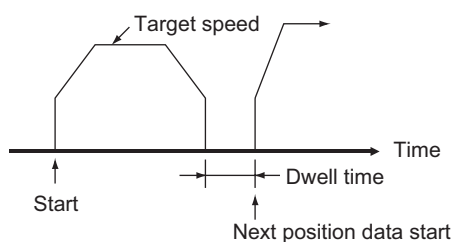

Continuous 1 (Until the Next Sequence Speed):

When the Memory Operation Start Bit in the Memory Operation Command Memory Area turns ON, the specified sequence is executed and then the next sequence is executed without stopping.

For a continuous 1 end pattern, the speed for the next sequence is reached before reaching the position of the specified sequence.

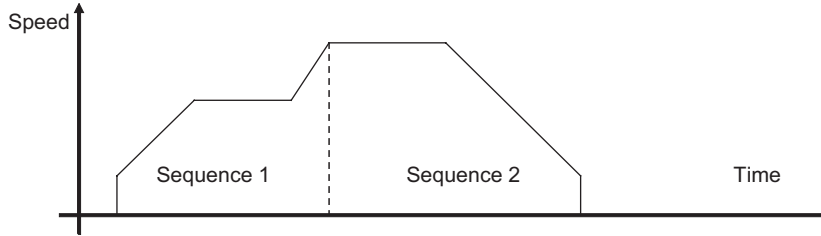

Continuous 2 (Acceleration/Deceleration Starts at the Next Sequence):

When the Memory Operation Start Bit in the Memory Operation Command Memory Area turns ON, the specified sequence is executed and then the next sequence is executed without stopping.

For a continuous 2 end pattern, the acceleration or deceleration for the next sequence starts after reaching the position for the specified sequence.

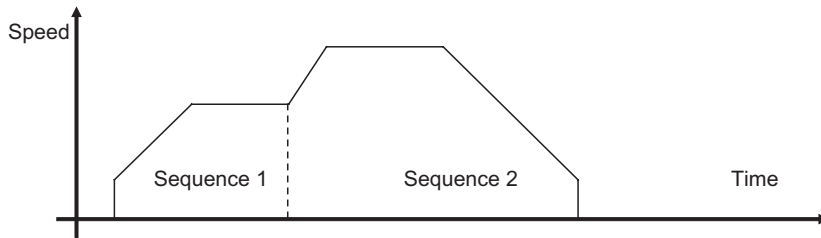

Continuous 3 (Overlapping Deceleration in the Applicable Sequence and Acceleration in the Next Sequence):

When the Memory Operation Start Bit in the Memory Operation Command Memory Area turns ON, the specified sequence is executed and then the next sequence is executed without stopping.

For a continuous 3 end pattern, the deceleration for the specified sequence and the acceleration for the next sequence are overlapped to achieve smooth interpolation operation.

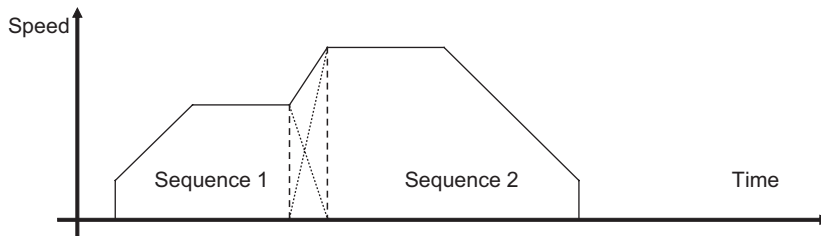



Precautions for Correct Use

Precautions on Continuous Operation

- ◆ Continuous 1 to 3 can be specified for linear interpolation or circular interpolation operation. To implement continuous operation, the next sequence must also be for linear interpolation or circular interpolation and must not have a sequence start condition.
- ◆ For the sequences you want to operate continuously, set the amount of movement that requires a positioning time of two control cycles or longer. If the required positioning time is less than two control cycles, the operation conforms to an automatic end pattern.

Dwell Timer

The dwell timer can be specified for operation commands when the end pattern is individual or automatic. The dwell time starts after positioning has been normally completed for the sequence. Dwelling is not applied for deceleration stop commands.

Positioning Completed Input Monitor Valid

Select the positioning completed operation to use when an axis stops. The end pattern must be Individual or Automatic. If this function is used in combination with the above dwell timer, the dwell time will start after the completion of positioning.

If you set 0 (not waiting for the completion of positioning), positioning will be considered to be completed when reference output has been completed.

Operation will not wait for the completion of positioning for deceleration stop commands.

For information on setting the positioning completed width, refer to *Positioning Completed Width Setting* on page 6-63.

If you set the Positioning Monitoring Time axis parameter to 0, arrival will not be monitored for the Servo Drive feedback position regardless of the setting of this parameter. Refer to *10-6 Positioning Completion* for details.

M Code

There are two types of M codes: M codes 1 to 499 require resetting, and M codes 500 to 999 do not require resetting.

M Code	Description
000	Do not output M code.
001 to 499	Use one of these M codes to trigger an interlock. Sequence execution is stopped until the M Code Reset Bit is turned ON.
500 to 999	Use one of these M codes when interlock is not necessary. The next sequence will be executed without waiting for the M code to be reset.

If you specify 000 or turn ON the Sequence Number Enable Bit, the M code is cleared to 0.

For information on the Sequence Number Enable Bit, refer to *Memory Operation Command Memory Area* on page 6-114.

Axis Specification

Specify the axes to start. Specify only an axis that is allocated in the Configuration Axes memory operation parameter.

For information on the Configuration Axes parameter, refer to *Configuration Axes* on page 6-72.

Circular Interpolation Method

In circular interpolation control, all interpolated axes must be set in Linear Mode.

For information on the setting method for Linear Mode, refer to *Command Position Unit Setting* on page 6-40.

You can use the following methods to specify circular interpolation.

Command method	Description
Circular Center Specification	This method uses the present position as the start point and the specified end point, center point, and rotation direction to perform circular interpolation.
Radius Specification	This method uses the present position as the start point and the specified end point, radius, and rotation direction to perform circular interpolation. If you specify the same position as the start point and end point, an error will occur.
Passing Point Specification	This method uses the present position as the start point and the specified end point and passing point to perform circular interpolation. Specifying 3 points, namely the start point, passing point and end point, determines the rotation direction. Therefore, the specification of circular direction is ignored. If the start point and end point are the same, however, the rotation direction is not determined and thus follows the circular direction.



Reference

If the start point and end point are clear and you want to perform circular interpolation to avoid something, specifying the center of the circle is useful.

Normally, the center point is calculated to perform complete circular operation for circular center specification.

When using circular interpolation to avoid something, however, it is difficult to calculate the center point accurately, although the start point and end point are clear. Here, the PCU calculates the average of two radii, namely the radius of specified center point to the start point and the radius of specified center point to the end point, and then recalculates the center point from those radii to perform circular interpolation. The specified rotation direction is maintained.

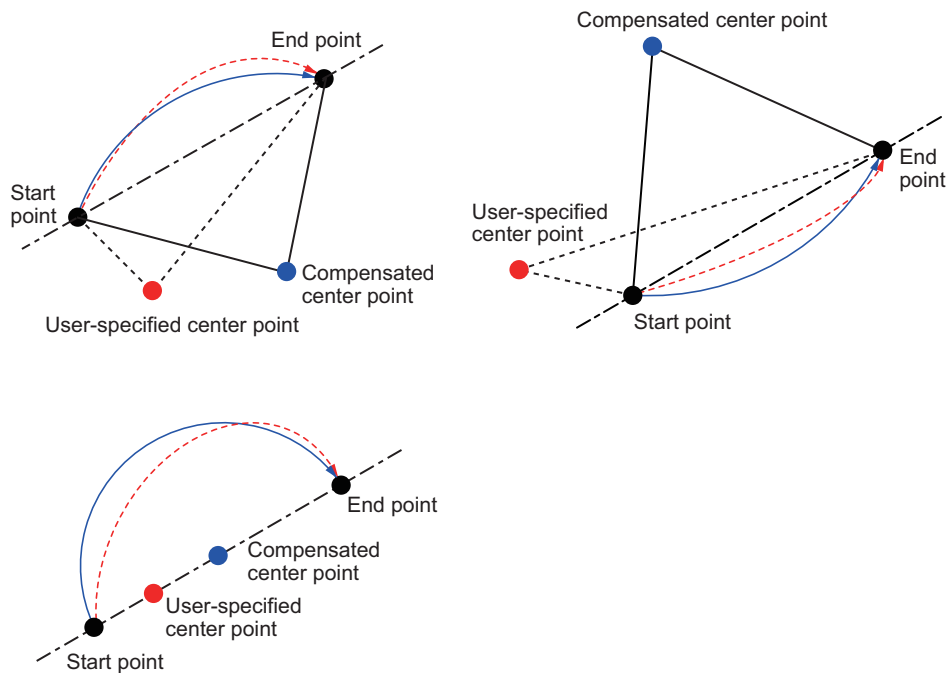

Position Specification

Set the absolute position designation or relative position designation for the command position. Only an axis that is allocated in the Configuration Axes memory operation parameter can be set.

For information on the Configuration Axes parameter, refer to *Configuration Axes* on page 6-72.

Interpolation Speed

Specify the speed of interpolation control.

Interpolation Acceleration Time/Interpolation Deceleration Time

Set the acceleration time and deceleration time for interpolation control.
 For the interpolation acceleration time and interpolation deceleration time, the setting of the Interpolation Acceleration/Deceleration Time Selection parameter determines the operation.

Interpolation Starting Speed

If you use a Servomotor, set this parameter to 0.

Interpolation Acceleration/Deceleration Curve Selection

Select the curve for interpolation acceleration and interpolation deceleration.

Trapezoid

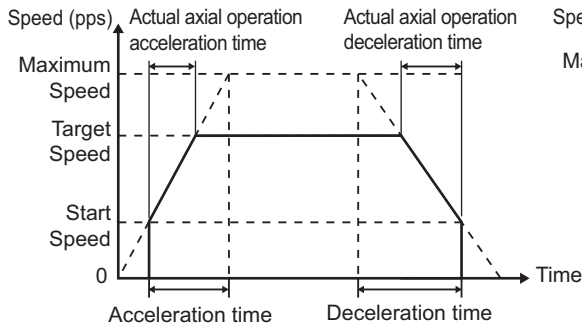

S-curve

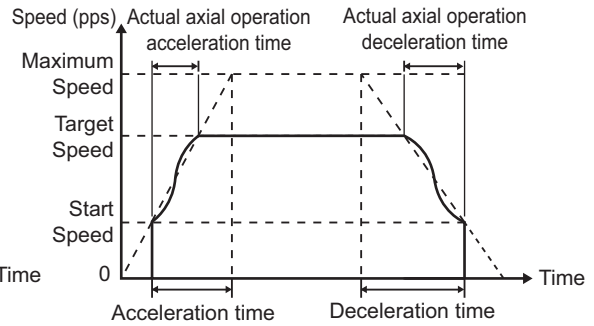

Interpolation Acceleration/Deceleration Time Selection

Select the method for the acceleration/deceleration time designation method. You can specify a constant acceleration/deceleration rate or a constant acceleration/deceleration time.

With a constant acceleration/deceleration rate, the acceleration/deceleration time is the time from the starting speed to the maximum speed. With this setting, the acceleration/deceleration time changes according to the target speed.

With a constant acceleration/deceleration time, the acceleration/deceleration time is the time from the present speed to the target speed. With this setting, the acceleration/deceleration time will not change. For triangle control, however, the acceleration/deceleration time is based on the acceleration that is calculated from the present speed, target speed, and acceleration/deceleration time.

Constant Acceleration Rate

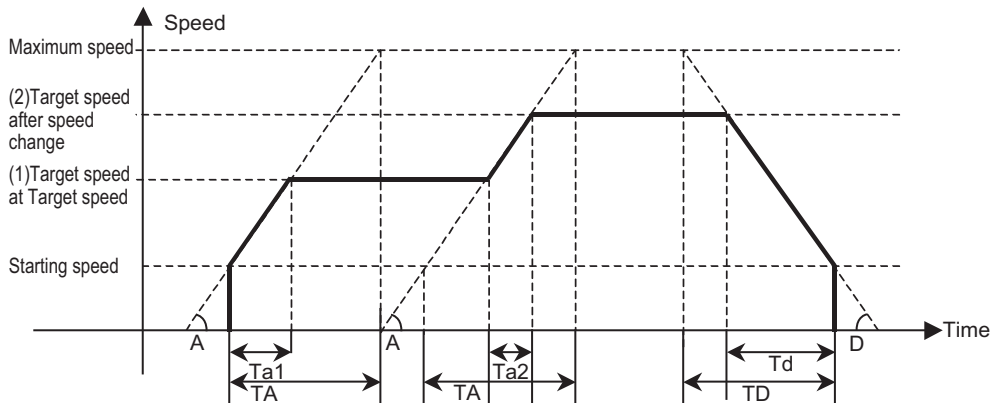

At Startup	For Speed Changes	During Deceleration
TA: Acceleration time	TA: Acceleration time	TD: Deceleration time
Ta1: Actual acceleration time	Ta2: Actual acceleration time	Td: Actual deceleration time
A: Acceleration rate	A: Acceleration rate	D: Rate of deceleration

Constant Acceleration/Deceleration Time

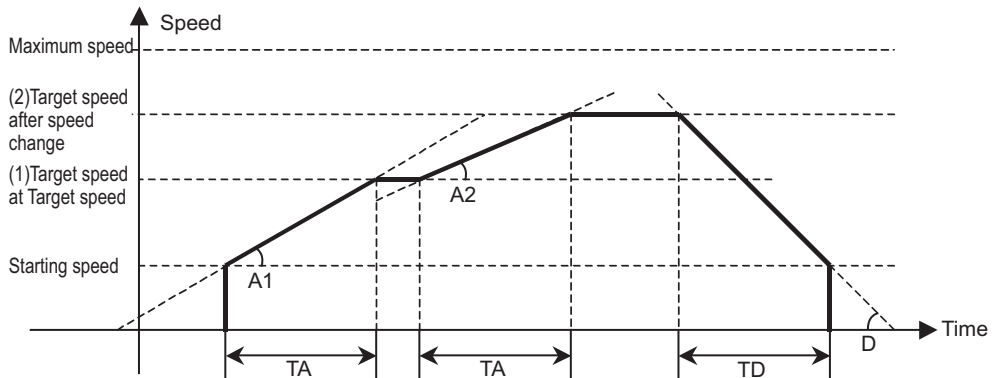

At Startup	For Speed Changes	During Deceleration
TA: Acceleration time	TA: Acceleration time	TD: Deceleration time
A1: Acceleration rate	A2: Acceleration rate	D: Rate of deceleration

Circular Center and Passing Point for Configuration Axes 1, 2, 3, and 4

If you set specifying the circular center for the circular interpolation method, set the center position of the circle.

If you set specifying a passing point for the circular interpolation method, set the position of a circle passing point.

Circular Radius

If you set specifying the radius for the circular interpolation method, set the circular radius.

Rotation Axis Direction for Configuration Axes 1, 2, 3 and 4

If you select a rotation axis in the applicable axis parameter, select the operating direction for positioning (PTP) for an absolute movement designation.

Command Speed for Configuration Axes 1, 2, 3 and 4

Set the target speed of each axis in positioning operation (PTP) and speed control.

The specified range is 1 to 2,147,483,647 (command units/s) for positioning, and -2,147,483,648 to 2,147,483,647 (command units/s) for speed control.

The speeds can be set in command units/s, but the setting must be between 1 and 104,857,600 (pps) for positioning and between -104,857,600 and 104,857,600 for speed control when converted to pulses.

Acceleration Time/Deceleration Time for Configuration Axes 1, 2, 3 and 4

Set the acceleration time and deceleration time of each axis for positioning (PTP).

The setting of the Acceleration/Deceleration Time Selection axis parameter determines the operation of the acceleration and deceleration times.

For information on the Acceleration/Deceleration Time Selection parameter, refer to *Acceleration/Deceleration Settings* on page 6-36 and *Acceleration/Deceleration Time Selection* on page 6-38.

Interpolation Speed Specification Method

Select the interpolation speed method for linear interpolation.

Interpolation path speed specification:

This method specifies the speed along the linear interpolation path.

Maximum speed specification:

This method automatically specifies the speed that can achieve the fastest operation by combining the maximum speeds of the interpolation axes.

Error Enable for Undetected Interrupt Input

This is the interrupt signal error detection setting for memory operation.

Use the axis parameters to set interrupt feeding for direct operation. For information on the setting for direct operation, refer to *Interrupt Feeding Settings* on page 6-50.

Interrupt Feeding Amount

This is the interrupt feeding amount for memory operation.

Use the axis parameters to set interrupt feeding for direct operation. For information on the setting for direct operation, refer to *Interrupt Feeding Settings* on page 6-50.

6-8 Memory Operation Condition Data

For memory operation condition data, you can set up to 100 conditions that apply to all tasks.

Condition data is referenced by Jump/Repeat Condition, Sequence Start Condition, and Sequence Skip Condition in the memory operation data. The condition data is used to assess True or False according to the conditional expression that you set for the referenced data.

For details on memory operation, refer to *Section 8 Memory Operation*.

Memory Operation Condition Data List

Memory operation condition data is continuously updated.

Each condition data set includes the following settings. There are some settings that you do not need to set depending on the condition data.

Parameter name	Function	Setting range	Unit	Default value
Condition	Set the comparison condition. 0000 hex: Condition data not yet set 0010 hex: ON (bit comparison) 0011 hex: OFF (bit comparison) 0012 hex: AND (bit comparison) 0013 hex: OR (bit comparison) 0020 hex: = (data comparison: 2 words) 0021 hex: ≠ (data comparison: 2 words) 0022 hex: ≥ (data comparison: 2 words) 0023 hex: ≥ (data comparison: 2 words) 0030 hex: Timer (time specification) 0040 hex: Counter (count specification) The following can be specified only for sequence start conditions. 0101 hex: Configuration axis 1 external interrupt input 0102 hex: Configuration axis 2 external interrupt input 0103 hex: Configuration axis 3 external interrupt input 0104 hex: Configuration axis 4 external interrupt input 0200 hex: Start with command			0
Edge Selection	Select how to evaluate the conditional expression. 0: Level assessment 1: Edge assessment	0 to 1	–	0
Data 1 Area Selection	Specify the data 1 area for comparison. 0: PCU Control Memory Area (Output/Input) 1: Manual Operation Command Memory Area (Output) 2: Direct Operation Command Memory Area (Output) 3: Memory Operation Command Memory Area (Output) 4: Axis Status Memory Area (Input) 5: Memory Operation Status Memory Area (Input) 6: Expanded Monitor Memory Area (Input) F: Constant (You can set a constant for either comparison data 1 or data 2, but not both.)	0 to 6, 000F hex	–	0

Parameter name	Function	Setting range	Unit	Default value
Data 1 Word Offset	Specify the word position as the offset from the first word of the target area that you specified for the Data 1 Area Selection. This will be the first word for data comparison.	0 to 255	–	0
Data 1 Bit	Specify the bit position in the target word that you specified for the Data 1 Area Selection and Data 1 Word Offset. This setting is enabled only for the bit comparison.	0 to 15	–	0
Data 2 Area Selection	Specify the data 2 area for comparison. 0: PCU Control Memory Area (Output/Input) 1: Manual Operation Command Memory Area (Output) 2: Direct Operation Command Memory Area (Output) 3: Memory Operation Command Memory Area (Output) 4: Axis Status Memory Area (Input) 5: Memory Operation Status Memory Area (Input) 6: Expanded Monitor Memory Area (Input) F: Constant (You can set a constant for either comparison data 1 or data 2, but not both.)	0 to 6, 000F hex	–	0
Data 2 Word Offset	Specify the word position as the offset from the first word of the target area that you specified for the Data 2 Area Selection. This will be the first word for data comparison.	0 to 255	–	0
Data 2 Bit	Specify the bit position in the target word that you specified for the Data 2 Area Selection and Data 2 Word Offset. This setting is enabled only for the bit comparison.	0 to 15	–	0
Timer	Set the time to be applied when you specify a timer for the conditional expression.	0 to 1,000	10 ms	0
Counter	Specify the count to be applied when you specify a counter for the conditional expression.	0 to 10,000	times	0
Constant	Set the constant when the condition is data comparison and a constant is specified for data 1 or data 2.	-2,147,483,648 to 2,147,483,647	–	0



Precautions for Correct Use

The specified reference data (word or constant data) that is used in data comparison for memory operation condition data is treated as signed 32-bit binary data. If the specified reference data is not signed 32-bit binary data, correct comparison results may not be achieved. Check the results of comparison operations sufficiently before using the data as data comparison conditions.

For example, if a GX-series Remote I/O Terminal Encoder Input Slave (GX-EC02□1) is connected, the Encoder Input Slave will input the present position, latch position, or other data as unsigned 32-bit data. The Position Control Unit, however, would treat this data as signed 32-bit data in the comparison operations, so any data that exceeds 31 bits (2,147,483,648 to 4,294,967,295) will be treated as two's complements (-2,147,483,648 to -1).

Therefore, you must make sure that the values in conditional expressions for memory operation condition data comparison do not exceed 31 bits before you set the data.

Details of Memory Operation Condition Data

This section describes the memory operation condition data.

Condition

Select the conditional expression to use for comparison.

Condition	Judgment method
ON (bit comparison)	If the specified bit is ON, the condition is True. The specified bit is the data 1 bit.
OFF (bit comparison)	If the specified bit is OFF, the condition is True. The specified bit is the data 1 bit.
AND (bit comparison)	If both of the 2 specified bits are ON, the condition is True. Specify the data 1 bit and data 2 bit.
OR (bit comparison)	If either of the 2 specified bits is ON, the condition is True. Specify the data 1 bit and data 2 bit.
Data comparison (2 words)	If the comparison result of the specified 2 data is satisfied, the condition is True. Specify two words of signed data for comparison.
Timer (time specification)	The condition is True after the wait time specified in units of 10 ms. Only an edge assessment can be specified for the Edge Selection. An error will occur if level assessment is selected.
Counter (count specification)	Specify the count. Countdown continues every time the condition is referenced. If the countdown result is 0, the condition is False. If the result is other than 0, the condition is True. Once the countdown result becomes 0, the count value is also reset. Only a level assessment can be specified for the Edge Selection. An error will occur if edge assessment is selected. An error also occurs if you set the Count specification for any command other than FOR and NEXT.
External interrupt input	This condition can be specified only for a sequence start condition. If the external interrupt input is ON, the condition is True. You can specify both edge and level assessment for the Edge Selection. If you specify an edge assessment, an interrupt process starts when the external interrupt input turns ON. You can select an external interrupt input only for an axis that you specified in the Configuration Axes memory operation parameter.
Instruction start	This condition can be specified only for a sequence start condition. The sequence is started when the PCU POSITIONING TRIGGER* ¹ instruction is executed for the task from the PLC when waiting for the start condition. Only an edge assessment can be specified for the Edge Selection. An error will occur if level assessment is selected.

*1. Refer to *PCU POSITIONING TRIGGER* on page 6-168.

Edge Selection

Edge assessment and level assessment can be set as the methods to evaluate a conditional expression for conditions other than a timer (time designation) or counter (count designation).

Level Assessment

With a level assessment, True/False are determined when you assess the condition data.

Edge Assessment

With an edge assessment, the program waits until the condition changes from True to False to True, if the condition is already True before assessing the condition data.

Condition data for JUMP command always conforms to the operation for level assessment.

Application Example

For example, assume there is a sequence for which you specify positioning and set a skipping condition.

If the condition is True before you execute the sequence,

- ♦ positioning is not performed and the sequence is skipped for a level assessment.
- ♦ For an edge assessment, positioning is executed and if the condition changes from True to False to True during execution, the sequence skips at that point.

Data 1 Area Selection

Specify the area for the left side of the conditional expression for comparison.

You can set only data 1 or data 2 to a constant for data comparison.

Data 1 Word Offset

Specify the word address of data 1 (left-side data) for comparison condition. Specify the number of offset words.

Specify the word address as an offset in words from the beginning word in the target area that you specified for the data 1 area selection.

Data 1 Bit

Specify the bit position in the word set for data 1 (left-side data). This setting is enabled only for bit comparison.

Data 2 Area Selection

Specify the area for the right side of the conditional expression for comparison.

You can set only data 1 or data 2 to a constant for data comparison.

Data 2 Word Offset

Specify the word address of data 2 (right-side data) for comparison condition. Specify the number of offset words.

Specify the word address as an offset in words from the first word in the target area that you specified for the Data 2 Area Selection.

Data 2 Bit

Specify the bit position in the word set for data 2 (right-side data). This setting is enabled only for bit comparison.

Timer

If you select a timer condition (time designation), set the time for timer condition.

Counter

If you select a counter condition (count designation), set the count for counter condition.

Constant

Set a constant when the condition is data comparison and data 1 or data 2 specifies a constant. You can only set either data 1 or data 2.

PCU POSITIONING TRIGGER

The PCU POSITIONING TRIGGER instruction is used to start a specified sequence for memory operation when the sequence is waiting for the start condition.

NCDTR(219) is a special PCU instruction supported by CJ2M-CPU and CJ2H-CPU CPU Units with unit version 1.3 or later. It cannot be used with any other CPU Units.

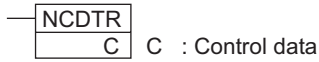

Operands

Operand	Description	Settings
C	Control data	C: Task number (0001 to 0004 hex) C+1: Unit number (8000 to 800F hex)



Reference

When the PCU POSITIONING TRIGGER instruction is used for a PTP positioning operation, sequence data is read in advance when a command is received to start memory operation. Therefore, an axis can be started in 0.4 ms (minimum time) of executing the instruction in the CPU Unit, in the same way as for a high-speed PTP start.

This function is convenient for high-speed starting of multiple axes.

However, high-speed starting is not possible for commands for linear interpolation, circular interpolation, speed control, and interrupt feeding.

7

Direct Operation

This section describes the procedure to perform direct operation, including setting the operation data and operation methods.

7-1	Outline of Direct Operation	7-1
7-2	Setting Direct Operation Data.....	7-2
7-3	Operations in Direct Operation.....	7-12
7-4	Timing Charts.....	7-16
7-5	Starting High-speed PTP Positioning	7-18
7-6	Example of Acceleration/ Deceleration Operation.....	7-24
7-7	Programming Example.....	7-30
7-8	Monitoring with CX-Programmer.....	7-39

7-1 Outline of Direct Operation

With direct operation, you can perform positioning simply by writing the position data and speed data in the Direct Operation Command Memory Area that is specified in the common parameters.

The position data and speed data that you set in the Direct Operation Command Memory Area (e.g., using MOVL instructions) is automatically output to the PCU during the I/O refresh period.



Precautions for Correct Use

Direct operation can be used only when the Position Control Unit is used together with an OMNUC G5-series Servo Drive.

Direct Operation Procedure

This section describes the procedure to perform direct operation.

1. Common Parameter Settings

To perform direct operation, set these three areas: Manual Operation Command Memory Area, Direct Operation Command Memory Area, and Axis Status Memory Area.

For information on setting these areas, refer to *6-3 Common Parameters* on page 6-15.

2. Axis Parameter Settings

Set the maximum speed, output settings, and other axis parameters.

For information on the axis parameters, refer to *6-4 Axis Parameters* on page 6-29.

3. Transferring Data

Transfer the common parameters and axis parameters to the PCU.

4. Saving Data

Save the data to the flash memory in the PCU.

5. Restarting the PCU

6. Put the Servo Drive in operating status.

7. Execute an origin search.

8. Settings in the Direct Operation Command Memory Area

Set the position data, speed data, acceleration time, deceleration time, and other data in the Direct Operation Command Memory Area.

9. Starting Direct Operation

Turn ON the Absolute Movement Bit or Relative Movement Bit in the Direct Operation Command Memory Area.

7-2 Setting Direct Operation Data

This section briefly describes the Manual Operation Command Memory Area, Direct Operation Command Memory Area, and Axis Status Memory Area. These areas are used to execute direct operation.

For the setting methods and details, refer to *6-6 Operation Memory Areas* on page 6-75.

For the setting methods and details on common parameter and axis parameter, refer to *6-3 Common Parameters* on page 6-15 and *6-4 Axis Parameters* on page 6-29, respectively.

Bits and Words Used in Direct Operation

This section describes the data settings and bits that you use in direct operation. Axis 1 is used as an example.

Manual Operation Command Memory Area

This area contains command bits, such as the Servo Lock Bit and Origin Search Bit.

For information on the setting method for the Manual Operation Command Memory Area, refer to *Manual Operation Command Memory Area Selection* on page 6-17.

The following table lists the memory allocations when you set the First Word of Manual Operation Command Memory Area parameter to word "A."

Words	Name	Bit	Bit name	Function
A	Axis 1 Manual Operation Command Bits	0	Servo Lock Bit	Turn ON this bit to lock the servo.
		1	Drive Alarm Reset Bit	Turn ON this bit to reset the Servo Drive alarm.
		2	Deviation Counter Reset Bit	Turn ON this bit to reset the deviation counter.
		3	Forward Torque Limit Bit	Use this bit to enable or disable the forward torque limit. ON: Enabled, OFF: Disabled
		4	Reverse Torque Limit Bit	Use this bit to enable or disable the reverse torque limit. ON: Enabled, OFF: Disabled
		5	Override Enable Bit	Specify whether to enable or disable an override. ON: Enabled, OFF: Disabled
		6	Jogging/Inching Speed Selection Bit	Select the jogging/inching speed. Turn OFF this bit to select speed 1 and turn ON this bit to select speed 2.
		7	Forward Jogging/Inching Bit	Turn ON this bit to perform jogging or inching in the forward direction.
		8	Reverse Jogging/Inching Bit	Turn ON this bit to perform jogging or inching in the reverse direction.
		9	Not used.	Do not use.

7-2 Setting Direct Operation Data

Words	Name	Bit	Bit name	Function
A (continued)	Axis 1 Manual Operation Command Bits	10	Origin Search Bit	Turn ON this bit to start an origin search.
		11	Origin Return Bit	Turn ON this bit to start an origin return.
		12	Not used.	Do not use.
		13	Immediate Stop Bit	Turn ON this bit to start performing an immediate stop.
		14	Deceleration Stop Bit	Turn ON this bit to start performing a deceleration stop.
		15	Servo Unlock Bit	Turn ON this bit to unlock the servo.
A+1	Axis 1 Override	0 to 15	Set the override in hexadecimal. You can set any value from 1 to 50,000 (0001 to C350 hex), which correspond to 0.01% to 500.00%.	

7

Direct Operation



Precautions for Correct Use

- ◆ Turn OFF the Deceleration Stop Bit as soon as the Deceleration Stop Acknowledged Flag in the Axis Status Memory Area turns ON. If the Deceleration Stop Bit remains ON, the PCU may not acknowledge other commands for the axis.

Direct Operation Command Memory Area

This area is used to set data for direct operation, such as the start command bits for absolute movements, relative movements, and speed control, as well as position data, speed data, acceleration times, and deceleration times.

For information on the setting method for the Direct Operation Command Memory Area, refer to *Direct Operation Command Memory Area Selection* on page 6-18.

The following table lists the memory allocations when you set the First Word of Direct Operation Command Memory Area parameter to word "B."

Words	Name	Bit	Bit name	Function
B	Axis 1 Direct Operation Command Bits	0	Absolute Movement Bit	Turn ON this bit to start an absolute positioning operation.
		1	Relative Movement Bit	Turn ON this bit to start a relative positioning operation.
		2	Speed Control Bit	Turn ON this bit to start speed control.
		3 to 4	Not used.	Do not use.
		5	Interrupt Feeding Specification Bit	Enable or disable interrupt feeding when the Absolute Movement Bit, Relative Movement Bit, or Speed Control Bit turns ON. ON: Enabled, OFF: Disabled
		6	Interrupt Input Mask/ Present Position Latch Enable Bit	Use this bit to enable the interrupt input mask for interrupt feeding and enable the present position latch for the interrupt input. ON: Enabled, OFF: Disabled
		7	Present Position Preset Bit	Turn ON this bit to preset the present position.

Words	Name	Bit	Bit name	Function
B (continued)	Axis 1 Direct Operation Command Bits	8	Synchronous Feeding Position Bit ^{*1}	While this bit is ON, the unit performs synchronous feeding position control.
		9	Synchronous Feeding Velocity Bit ^{*1}	While this bit is ON, the unit performs synchronous feeding velocity control.
		10	Synchronous Feeding Torque Bit ^{*1}	While this bit is ON, the unit performs synchronous feeding torque control.
		11	Origin Position Latch Enable Bit ^{*1}	Enables the origin position latch. ON: Enabled, OFF: Disabled
		12 to 13	Not used.	Do not use.
		14	Origin Position Latch Clear Bit ^{*1}	Turn this bit ON to clear the Origin Position Latch Completed Flag.
		15	Latch Completed Flag Clear Bit	Turn this bit ON to clear the Latch Completed Flag.
B+1	Axis 1 Rotation Axis Direction	0 to 15	Specify the operating direction to be applied when you execute an absolute movement for an infinite axis. 0: Shortest route 1: Forward 2: Reverse 3: Not specified	
B+2	Axis 1 Command Position (lower word)	0 to 15	Specify the position to be used in direct operation or present position preset. Set the value in command units in hexadecimal.	
B+3	Axis 1 Command Position (upper word)	0 to 15	Setting range: 8000 0000 to 7FFF FFFF hex (-2,147,483,648 to 2,147,483,647 command units)	
B+4	Axis 1 Command Speed (lower word)	0 to 15	Specify the target speed to be used in direct operation. Set the value in command units/s in hexadecimal.	
B+5	Axis 1 Command Speed (upper word)	0 to 15	Setting Ranges: Position control: 1 to 7FFF FFFF hex (1 to 2,147,483,647 command units/s) Speed control: 8000 0000 to 7FFF FFFF hex (-2,147,483,648 to 2,147,483,647 command units/s)	
B+6	Axis 1 Option Input 1 ^{*1}	0 to 15	Forward Torque Limit Data ^{*2} Specify the torque limit value when the forward torque limit is enabled. Setting range: 0 to 2710 hex (0 to 10000 [0.1%]) Set the value in 0.1%.	
B+7	Axis 1 Option Input 2 ^{*1}	0 to 15	Reverse Torque Limit Data ^{*3} Specify the torque limit value when the reverse torque limit is enabled. Setting range: 0 to 2710 hex (0 to 10000 [0.1%]) Set the value in 0.1%.	
B+8	Axis 1 Acceleration time (lower word)	0 to 15	Specify the acceleration time. Set the value in ms in hexadecimal. Setting range: 0 to 3D090 hex (0 to 250,000 ms)	
B+9	Axis 1 Acceleration time (upper word)	0 to 15		

7-2 Setting Direct Operation Data

Words	Name	Bit	Bit name	Function
B+10	Axis 1 Deceleration time (lower word)	0 to 15	Specify the deceleration time. Set the value in ms in hexadecimal. Setting range: 0 to 3D090 hex (0 to 250,000 ms)	
B+11	Axis 1 Deceleration time (upper word)	0 to 15		

*1. Available with version 1.3 or later PCUs.

*2. Available only when the positive torque limit value(60E0h) is mapped.

*3. Available only when the reverse torque limit value (60E1h) is mapped.



Precautions for Correct Use

- ♦ The setting of the Acceleration/Deceleration Time Selection parameter determines the operation of the acceleration and deceleration times. For information on the Acceleration/Deceleration Time Selection parameter, refer to *Acceleration/Deceleration Settings* on page 6-36 and *Acceleration/Deceleration Time Selection* on page 6-38.

Axis Status Memory Area

This area is used to confirm the axis status, such as axis busy and positioning operation completed status.

For information on the setting method for the Axis Status Memory Area, refer to *Axis Status Memory Area Selection* on page 6-19.

The following table shows the allocations when the First Word in the Axis Status Memory Area parameter is set to word "C."

Words	Name	Bit	Bit name	Function
C	Axis 1 Manual Operation Command Acknowledged Flags	0	Servo Lock Acknowledged Flag	This flag turns ON to acknowledge the Servo Lock Bit.
		1	Drive Alarm Reset Acknowledged Flag	This flag turns ON to acknowledge the Drive Alarm Reset Bit.
		2	Deviation Counter Reset Acknowledged Flag	This flag turns ON to acknowledge the Deviation Counter Reset Bit.
		3	Forward Torque Limit Acknowledged Flag	This flag turns ON to acknowledge the Forward Torque Limit Bit.
		4	Reverse Torque Limit Acknowledged Flag	This flag turns ON to acknowledge the Reverse Torque Limit Bit.
		5	Override Enable Acknowledged Flag	This flag turns ON to acknowledge the Override Enable Bit.
		6	Jogging/Inching Speed Selection Acknowledged Flag	This flag turns ON to acknowledge the Jogging/Inching Speed Selection Bit.

Words	Name	Bit	Bit name	Function
C (continued)	Axis 1 Manual Operation Command Acknowledged Flags	7	Forward Jogging/Inching Acknowledged Flag	This flag turns ON to acknowledge the Forward Jogging/Inching Bit.
		8	Reverse Jogging/Inching Acknowledged Flag	This flag turns ON to acknowledge the Reverse Jogging/Inching Bit.
		9	Not used.	Do not use.
		10	Origin Search Acknowledged Flag	This flag turns ON to acknowledge the Origin Search Bit.
		11	Origin Return Acknowledged Flag	This flag turns ON to acknowledge the Origin Return Bit.
		12	Not used.	Do not use.
		13	Immediate Stop Acknowledged Flag	This flag turns ON to acknowledge the Immediate Stop Bit.
		14	Deceleration Stop Acknowledged Flag	This flag turns ON to acknowledge the Deceleration Stop Bit.
		15	Servo Unlock Acknowledged Flag	This flag turns ON to acknowledge the Servo Unlock Bit.
C+1	Axis 1 Direct Operation Command Acknowledged Flags	0	Absolute Movement Acknowledged Flag	This flag turns ON to acknowledge the Absolute Movement Bit.
		1	Relative Movement Acknowledged Flag	This flag turns ON to acknowledge the Relative Movement Bit.
		2	Speed Control Acknowledged Flag	This flag turns ON to acknowledge the Speed Control Bit.
		3 to 4	Not used.	Do not use.
		5	Interrupt Feeding Specification Acknowledged Flag	This flag turns ON to acknowledge the Interrupt Feeding Specification Bit.
		6	Interrupt Input Mask/Present Position Latch Enable Acknowledged Flag	This flag turns ON to acknowledge the Interrupt Input Mask/Present Position Latch Enable Bit.
		7	Present Position Preset Acknowledged Flag	This flag turns ON to acknowledge the Present Position Preset Bit.
		8	Synchronous Feeding Position Acknowledged Flag ^{*1}	This flag turns ON to acknowledge the Synchronous Feeding Position Bit.
		9	Synchronous Feeding Velocity Acknowledged Flag ^{*1}	This flag turns ON to acknowledge the Synchronous Feeding Velocity Bit.

7-2 Setting Direct Operation Data

Words	Name	Bit	Bit name	Function
C+1 (continued)	Axis 1 Direct Operation Command Acknowledged Flags	10	Synchronous Feeding Torque Acknowledged Flag ^{*1}	This flag turns ON to acknowledge the Synchronous Feeding Torque Bit.
		11	Origin Position Latch Enable Acknowledged Flag ^{*1}	This flag turns ON to acknowledge the Origin Position Latch Enable Bit.
		12 to 13	Not used.	Do not use.
		14	Origin Position Latch Clear Acknowledged Flag ^{*1}	This flag turns ON to acknowledge the Origin Position Latch Completed Flag Clear Bit.
		15	Latch Completed Flag Clear Acknowledged Flag	This flag turns ON to acknowledge the Latch Completed Flag Clear Bit.
C+2	Axis 1 Command Status	0	Axis Busy Flag	This flag turns ON during axis operation. During memory operation, the Busy Flags for axes that are not assigned in the axis configuration will turn ON even if there is no axis operation.
		1	Jogging Enabled Flag	This flag turns ON when jogging can be started.
		2	Direct Operation Enabled Flag	This flag turns ON when direct operation can be started.
		3	Not used.	Do not use.
		4	Stop Input Flag	This flag will turn ON when the Immediate Stop Bit or the Deceleration Stop Bit is acknowledged or when the emergency stop input or deceleration input is received. Other start command bits will not be acknowledged while this flag is ON.
		5	Synchronous Group Stop Input Flag ^{*1}	This flag turns ON when the Synchronous Group Stop Bit in synchronized data is acknowledged and the system is stopped and when the Synchronous Group Stop Bit is ON.
		6	All Synchronized Unit Stop Input Flag ^{*1}	This flag turns ON when the All Synchronized Unit Stop Bit in synchronized data is acknowledged and the system is stopped and when the All Synchronized Unit Stop Bit is ON.
		7	High-speed PTP Start Acknowledged Flag	This flag turns ON to acknowledge a high-speed PTP start.
		8	Start Invalid Flag	This flag turns ON after the executed command has failed because it does not meet the conditions for starting the applicable function. This status is set when an operation cannot be started due to an error that occurs at the start of the command or because of the priority of the command.

Words	Name	Bit	Bit name	Function
C+2 (continued)	Axis 1 Command Status	9	Deviation Counter Reset Acknowledged Flag	This flag turns ON if the Deviation Counter Reset Bit is not acknowledged after the Deviation Counter Reset Bit is output during an origin search operation.
		10 to 11	Not used.	Do not use.
		12	Stop Executed Flag	This flag turns ON when axis operation has stopped for one of the following reasons during manual operation or direct operation. <ul style="list-style-type: none"> ♦ Stopping when a deceleration stop is executed, the deviation counter is reset, or the servo is unlocked ♦ Stopping when an error occurs
		13	Positioning Operation Completed Flag	This flag turns ON when positioning, an origin search, or an origin return has been finished in direct operation or when jogging is stopped in direct operation.
		14 to 15	Not used.	Do not use.
C+3	Axis 1 Axis Operation Status	0	Servo Unlocked Flag	This flag is ON while the servo is unlocked for the axis.
		1	Servo Locked Flag	This flag is ON when the axis is stopped in servo lock status.
		2	Not used.	Do not use.
		3	Acceleration Flag	This flag is ON while the axis is accelerating to the target speed. This flag can also be used for path status during interpolation.
		4	Constant Speed Flag	This flag is ON while the axis is moving at a constant speed after reaching the target speed. This flag can also be used for path status during interpolation.
		5	Deceleration Flag	This flag is ON while the axis is decelerating to the target position or to the target speed. This flag can also be used for path status during interpolation.
		6	Pass Flag	This flag is ON during acceleration/deceleration to the target speed of the next sequence for the continuous 1 or continuous 3 operation patterns. This flag can also be used for path status during interpolation.
		7	Positioning Completed Waiting Flag	This flag is ON while waiting for axis positioning to be completed. This flag can also be used for path status during interpolation.
		8	Deceleration Stop Flag	This flag is ON until the axis stops for a deceleration stop during axis operation.
		9	Immediate Stop Flag	This flag is ON until the axis stops for an immediate stop during axis operation.
		10 to 15	Not used.	Do not use.

7-2 Setting Direct Operation Data

7

Direct Operation

Words	Name	Bit	Bit name	Function
C+4	Axis 1 Operation Status	0	Origin Search Flag	This flag is ON during an origin search operation.
		1	Origin Return Flag	This flag is ON during an origin return operation.
		2	Not used.	Do not use.
		3	Jogging/Inching Flag	This flag is on during jogging or inching.
		4	Absolute Movement Flag	This flag is ON during a absolute movement. It is also ON until the interrupt feeding input is received.
		5	Relative Movement Flag	This flag is ON during an relative movement. It is also ON until the interrupt feeding input is received.
		6	Speed Control Flag	This flag is ON during speed control. It is also ON until the interrupt feeding input is received.
		7	Interrupt Feeding (Interrupt Input Waiting) Flag	This flag is ON during interrupt feeding until the interrupt input turns ON.
		8	Interrupt Feeding (Positioning) Flag	This flag is ON after the interrupt input turns ON during interrupt feeding.
		9 to 10	Not used.	Do not use.
		11	Memory Operation Flag	This flag is ON during memory operation.
		12	Not used.	Do not use.
		13	Synchronous Feeding Torque Flag ^{*1}	This flag is ON during synchronous feeding torque control operation. The axis movement reflects the command torque data stored in the Synchronous Data Link Memory Area.
		14	Synchronous Feeding Velocity Flag ^{*1}	This flag is ON during synchronous feeding velocity control operation. The axis movement reflects the command speed data stored in the Synchronous Data Link Memory Area.
15	Synchronous Feeding Position Flag ^{*1}	This flag is ON during synchronous feeding position operation. The axis movement reflects the position data for the auxiliary axis that is set with the Electric Shaft function and stored in the Synchronous Data Link Memory Area.		
C+5	Axis 1 Control Status	0	Origin Defined Flag	This flag is ON while the origin is defined. OFF: Origin not defined. ON: Origin defined.
		1	Stopped at Origin Flag	This flag is ON while the axis is stopped within the positioning completed width. It will not turn ON unless the origin is defined.
		2	Latch Completed Flag	This flag turns ON when the present position has been latched.
		3	Origin Position Latch Completed Flag ^{*1}	This flag turns ON when the origin position has been latched.
		4	Command Present Position Overflow Flag	This flag turns ON when an overflow occurs in the command position in Linear Mode.

Words	Name	Bit	Bit name	Function
C+5 (continued)	Axis 1 Control Status	5	Command Present Position Underflow Flag	This flag turns ON when an underflow occurs in the command position in Linear Mode.
		6	Feedback Present Position Overflow Flag	This flag turns ON when an overflow occurs in the feedback position in Linear Mode.
		7	Feedback Present Position Underflow Flag	This flag turns ON when an underflow occurs in the feedback position in Linear Mode.
		8	Sensor Error Flag	This flag turns ON when an error is detected for an external sensor, such as for the emergency stop input or a limit input.
		9	Servo Error Flag	This flag turns ON when a Servo Drive alarm occurs.
		10	Execution Error Flag	This flag turns ON when an error, such as a multi-start error, occurs after execution of a command for axis operation due to an invalid execution condition or command value.
		11	Axis Warning Flag	This flag turns ON when a warning occurs in memory operation.
		12	Axis Error Flag	This flag turns ON when an axis error occurs.
		13	Zone 0 Flag	This flag is ON while the present position is in zone 0.
		14	Zone 1 Flag	This flag is ON while the present position is in zone 1.
		15	Zone 2 Flag	This flag is ON while the present position is in zone 2.
C+6	Axis 1 External I/O Status	0	Servo ON Flag	This flag is ON while power is being supplied to the Servomotor.
		1	Alarm Reset Output Flag	This flag turns ON when an alarm reset is output.
		2	Deviation Counter Reset Output Flag	This flag turns ON when a deviation counter reset is output.
		3	Forward Torque Limit Output Flag	This flag turns ON when a forward torque limit is output.
		4	Reverse Torque Limit Output Flag	This flag turns ON when a reverse torque limit is output.
		5	Main Circuit Status Flag	This flag turns ON when a voltage is supplied to the main circuits.
		6	Servo Drive Warning Input Flag	This flag turns ON when a Servo Drive warning occurs.
		7	Servo Ready Flag	This flag turns ON when the servo is ready.
		8	Forward Limit Input Flag	This flag is ON while the forward limit input is being received.
		9	Reverse Limit Input Flag	This flag is ON while the reverse limit input is being received.
		10	Origin Proximity Input Flag	This flag is ON while the origin proximity input is being received.

7-2 Setting Direct Operation Data

Words	Name	Bit	Bit name	Function
C+6 (continued)	Axis 1 External I/O Status	11	Origin Input Flag	This flag is ON while the origin input is being received.
		12	Interrupt Input Flag	This flag is ON while the interrupt input is being received.
		13	Emergency Stop Input Flag	This flag is ON while the emergency input is being received.
		14	Positioning Completed Input Flag	This flag is ON while the axis is within the positioning completed width.
		15	Drive Alarm Input Flag	This flag turns ON when a drive alarm occurs.
C+7	Axis 1 Error Code	0 to 15	This word contains the axis error code.	
C+8	Axis 1 Command Present Position (lower word)	0 to 15	These words contain the present command position.	
C+9	Axis 1 Command Present Position (upper word)	0 to 15		
C+10	Axis 1 Expanded Monitor (lower word)	0 to 15	These words contain the monitor value that is specified by the Expanded Monitor Type axis parameter. For details, refer to <i>Expanded Monitor Settings</i> on page 6-59.	
C+11	Axis 1 Expanded Monitor (upper word)	0 to 15		

*1. Available with version 1.3 or later PCUs.

7-3 Operations in Direct Operation

This section describes the operations that can be performed in direct operation and multi-starting.

Starting Direct Operation

These four methods can be used to start direct operation.

- (1) Turn ON the Absolute Movement Bit.
- (2) Turn ON the Relative Movement Bit.
- (3) Turn ON the Speed Control Bit.
- (4) Turn ON the Interrupt Feeding Specification Bit, and turn ON the Absolute Movement Bit, Relative Movement Bit, or Speed Control Bit.

Executing Absolute Movements

The position command value in the Direct Operation Command Memory Area is used as absolute data to perform positioning.

PTP positioning is performed in direct operation.

Executing Relative Movements

The position command value in the Direct Operation Command Memory Area is used as increment data to perform positioning.

PTP positioning is performed in direct operation.

Executing Speed Control

Speed control with position loop in the CSP mode is performed according to the command speed in the Direct Operation Command Memory Area.

Specify the rotation direction by using the sign of the command speed.

To stop the operation, turn ON the Deceleration Stop Bit in the Manual Operation Command Bits for the axis.

Speed control is implemented through speed feeding with position control.

Executing Interrupt Feeding

There are three methods that can be used to start interrupt feeding.

You can specify interrupt feeding not only for speed control, but also for absolute movements and relative movements.

If you specify an absolute movement or relative movement, it is also possible to output an error if the interrupt input is not input within the specified travel distance.

For more information on interrupt feeding, refer to *Interrupt Feeding in Direct Operation* on page 10-9.

Operations in Direct Operation

Positioning operations with direct operation are determined by the data that you set in the Direct Operation Command Memory Area.

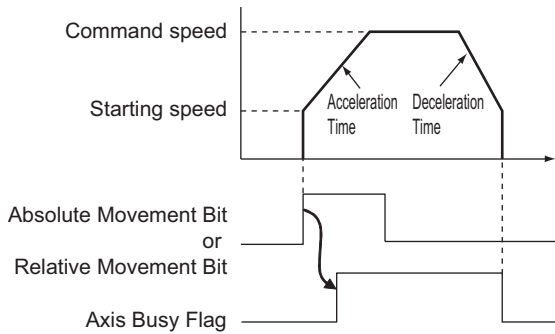

Precautions for Correct Use

- ♦ For an absolute movement, a relative movement, or speed control, keep the command bit ON until Absolute Movement Acknowledged Flag, Relative Movement Acknowledged Flag, or Speed Control Acknowledged Flag in the Axis Status Memory Area turns ON.

Deceleration Stop during Direct Operation

You can decelerate an axis to a stop according to the setting of the specified deceleration time by using the Deceleration Stop Bit.

Multi-starting Direct Operation

You can use multi-starting to change the target position during direct operation.

Multi-starting involves setting a new position command value in the Direct Operation Command Memory Area during operation and then starting an absolute movement or relative movement.

The current operation is stopped and the axis is started again according to the newly set data.

Before multi-starting an axis, check the Direct Operation Enabled Flag in the axis status.



Precautions for Correct Use

- ♦ You cannot perform multi-starting during direct operation using memory operation.
- ♦ You can perform multi-starting only during direct operation.



Reference

To change the target speed, acceleration time, and deceleration time, change the Speed Command, Acceleration Time, and Deceleration Time in Direct Operation Command Memory Area. The changes are reflected immediately.

Combinations for Multi-starting

Multi-starting is permitted except during interrupt feeding.
Refer to the multi-starting combination table.

○: Permitted, ×: Not permitted

Multi-started operation → During operation ↓	Absolute movement	Relative movement	Speed control	Interrupt feeding
Absolute movement	○	○	○	○
Relative movement	○	○	○	○
Speed control	○	○	○	○
Interrupt feeding	×	×	×	×



Precautions for Correct Use

All multi-starting during interrupt feeding operation results in a multi-start error.

Multi-starting Operations

The axis performs the operation shown below when the axis reverses due to multi-starting according to the setting of the Operation at Reverse Rotation Command parameter in the Acceleration/Deceleration Setting axis parameter.

Operation for Deceleration Stop When Reversing

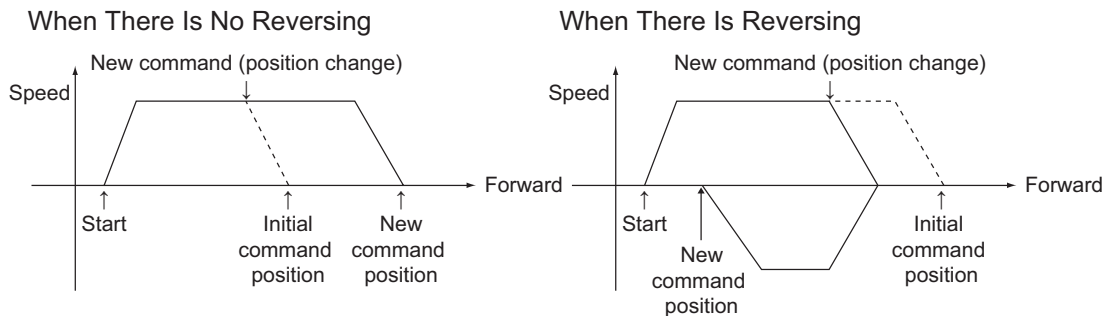

Operation for Immediate Stop When Reversing

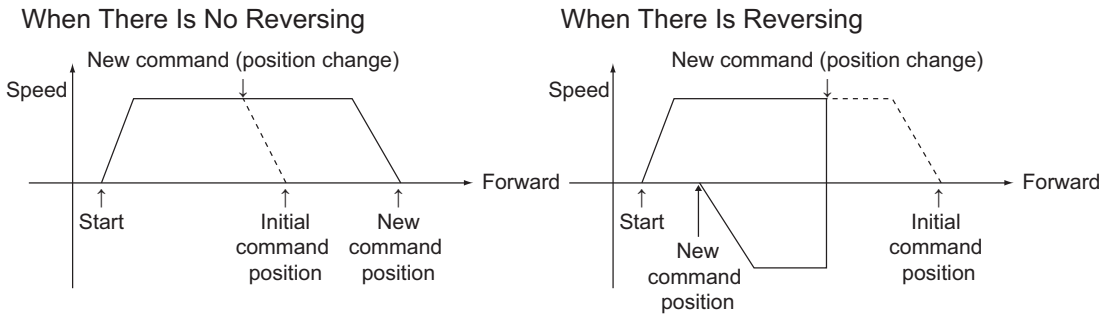

7-4 Timing Charts

This section provides the timing charts for absolute movement, relative movement, and speed control. Axis 1 is used as an example.

Example 1: Moving to a Relative Position of 10,000 Pulses

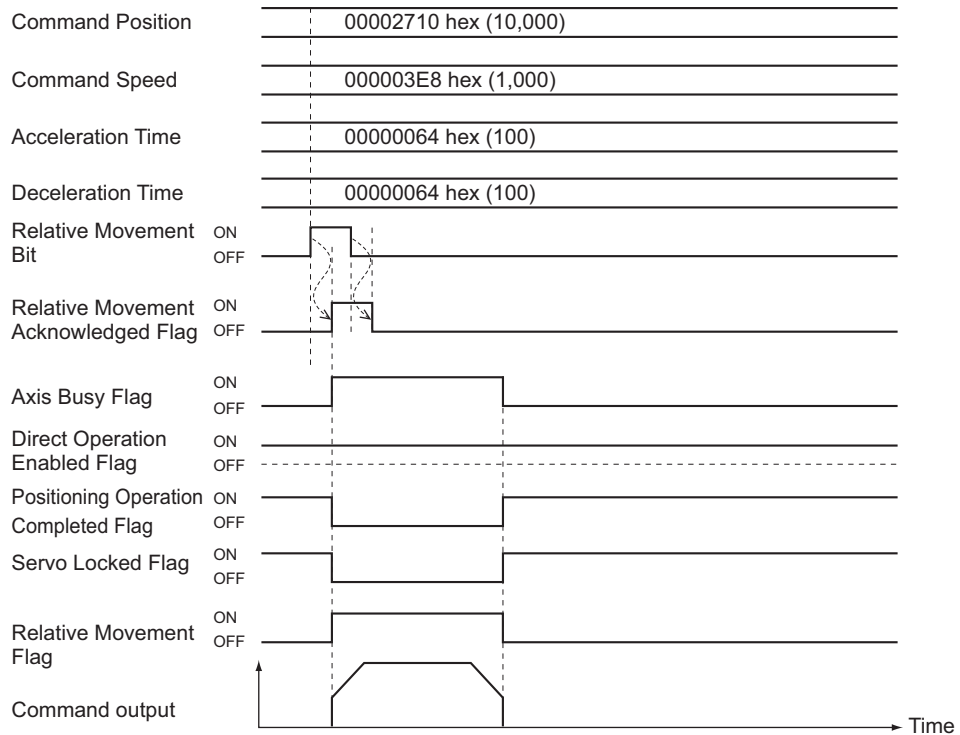

Example 2: Changing the Command Position to an Absolute Position of 10,000 Pulses during an Absolute Movement to 10,000 Pulses

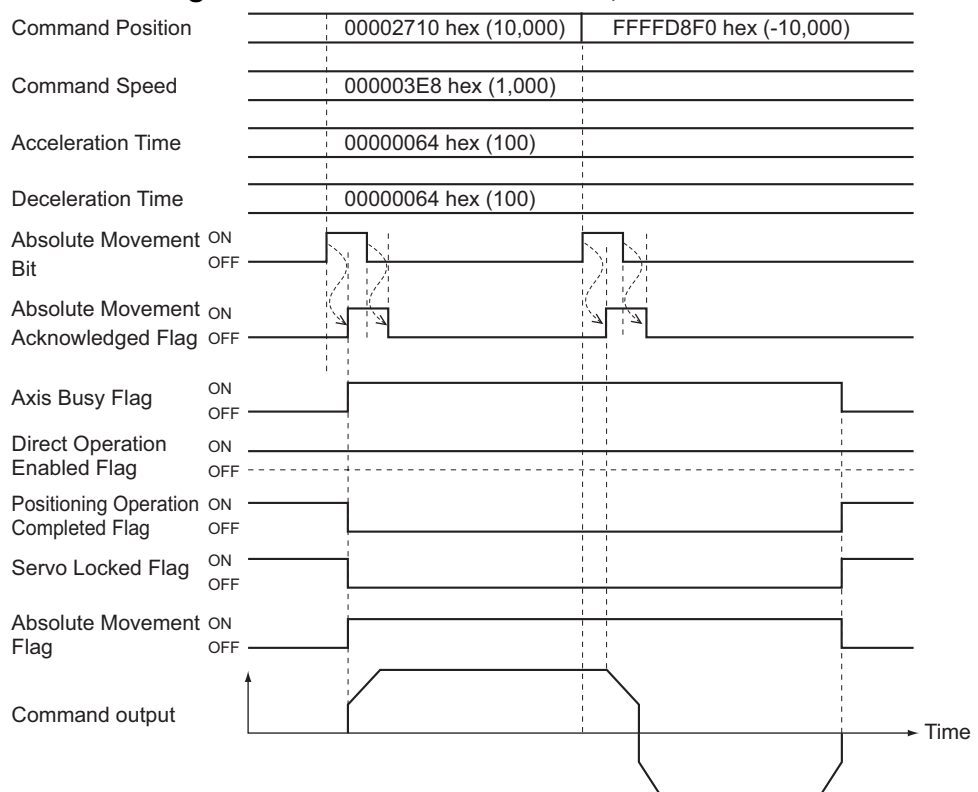

Example 3: Executing a Relative Movement to a Relative Position of 10,000 Pulses during Speed Control

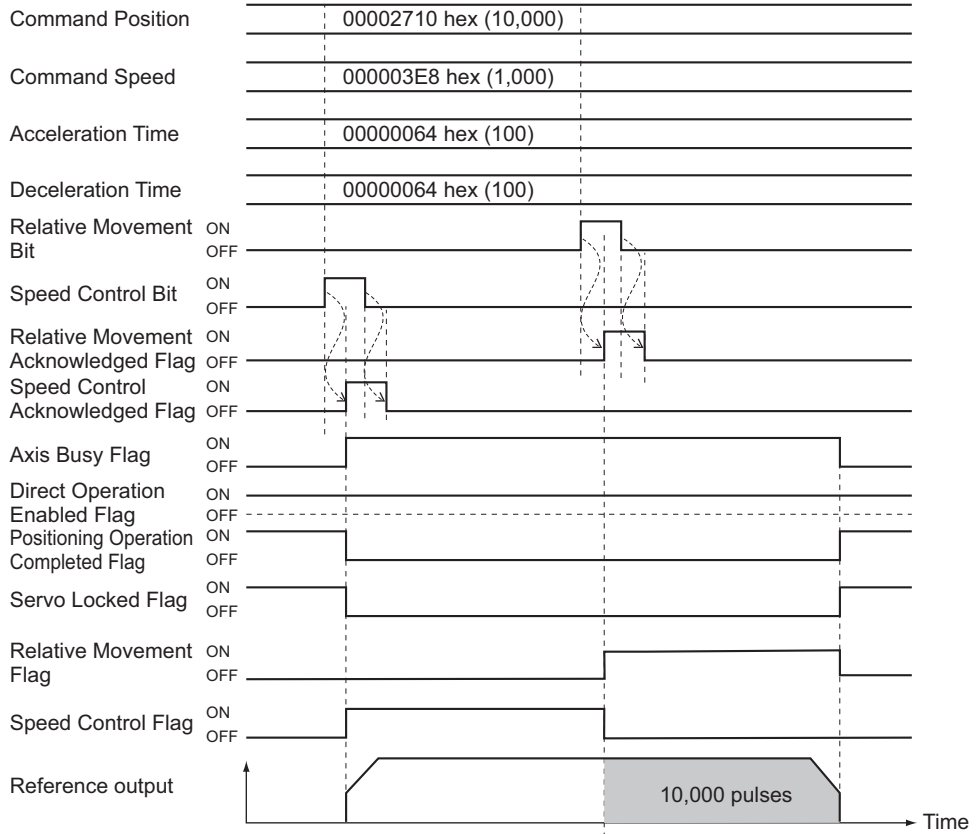

7

Direct Operation

7-5 Starting High-speed PTP Positioning

Direct operation can be started by turning ON the Absolute Movement Bit or Relative Movement Bit in the Direct Operation Command Memory Area. It can also be started by using the NCDMV(218) or IOWR(223) instruction in a ladder program.

NCDMV(218) can be used to start positioning as soon as it is executed in a ladder program. IOWR(223) will start positioning in the control cycle of the PCU.



Reference

NCDMV(218) is a special PCU instruction supported by CJ2M and CJ2H CPU Units with unit version 1.3 or later. Use IOWR(223) with other CPU Units.

Starting Procedure for High-speed PTP Positioning

High-speed PTP positioning is started by executing absolute or relative movements in direction operation using the NCDMV(218) or IOWR(223) instruction.

Except for the starting procedure, the procedures and operations are the same as those when you use the Absolute Movement Bit or Relative Movement Bit in the Direct Operation Command Memory Area.

You can start high-speed PTP positioning at the same time as the Absolute Movement Bits and Relative Movement Bits in the Direct Operation Command Memory Area.

This section describes the procedure to start high-speed PTP positioning.

Steps 1 to 8 are the same as those in *Direct Operation Procedure* on page 7-1.

1. Common Parameter Settings

To perform direct operation, set these three areas: Manual Operation Command Memory Area, Direct Operation Command Memory Area, and Axis Status Memory Area.

For information on setting these areas, refer to 6-3 *Common Parameters* on page 6-15.

2. Axis Parameter Settings

Set the maximum speed, output settings, and other axis parameters.

For information on the axis parameters, refer to 6-4 *Axis Parameters* on page 6-29.

3. Transferring Data

Transfer the common parameters and axis parameters to the PCU.

4. Saving Data

Save the data to the flash memory in the PCU.

5. Restarting the PCU

6. Put the Servo Drive in operating status.

7. Execute an origin search.

8. Settings in the Direct Operation Command Memory Area

Set the command position, command speed, acceleration time, deceleration time, and other data in the Direct Operation Command Memory Area.

9. Starting High-speed PTP Positioning in Direct Operation

High-speed PTP positioning is started with the NCDMV(218) or IOWR(223) instruction.

High-speed PTP Start Instructions

High-speed PTP positioning can be started using the NCDMV(218) or IOWR(223) instruction.

NCDMV(218)

NCDMV(218) is a special PCU instruction supported by CJ2M and CJ2H CPU Units with unit version 1.3 or later.

To start high-speed PTP positioning with CPU Units other than CJ2M CPU Units, use IOWR(223).

—	NCDMV	
	C	C: Control data (destination unit number)
	S	S: First source word

Operands

Operand	Description	Settings
C	Control data (destination unit number)	C: Set the movement method. Absolute movement: 00xx hex Relative movement: 01xx hex (xx = 01 to 10 hex: Axis 1 to 16) C+1: Set the unit number of the destination Unit. Set unit numbers 0 to F hex as 8000 to 800F hex.
S	First source word	Specify the first word (B) of the Direct Operation Command Memory Area.



Precautions for Correct Use

NCDMV(218) cannot be executed while IOWR(223) or IORD(222) is being executed.

IOWR(223)

IOWR
C
S
W

@IOWR
C
S
W

C: Control data
 S: First word of transfer source
 W: Destination unit number and number of words to transfer

Operands

Operand	Description	Settings
C	Control data	Use one of the following values to specify a high-speed PTP command. Absolute movement: 80xx hex Relative movement: 81xx hex (xx = 01 to 10 hex: Axis 1 to 16)
S	First source word	Specify the first word in the Direct Operation Command Memory Area for the axis for which you want to start high-speed PTP positioning. ^{*1} Axis 1: B Axis 5: B+48 Axis 9: B+96 Axis 13: B+144 Axis 2: B+12 Axis 6: B+60 Axis 10: B+108 Axis 14: B+156 Axis 3: B+24 Axis 7: B+72 Axis 11: B+120 Axis 15: B+168 Axis 4: B+36 Axis 8: B+84 Axis 12: B+132 Axis 16: B+180
W	Destination unit number and number of words to transfer	W: Set the unit number of the destination Unit. Set unit numbers 0 to F hex as #8000 to 800F hex. W+1: Set the number of words to transfer. Set the number of words that are allocated to the axis in the Direct Operation Command Memory Area. This value is always #000C.

*1. For information on the first word of the Direct Operation Command Memory Area, refer to *Direct Operation Command Memory Area* on page 6-91.



Precautions for Correct Use

- When IOWR(223) is used to start high-speed PTP positioning, processing will occur with the same control cycle as for positioning that is started with the normal command bits. Therefore, the starting time for positioning is the same as when starting with the command bits.
- Positioning can be started for only one axis at a time with each IOWR(223) or NCDMV(218) instruction.
Also, only absolute movements and relative movements can be used. You cannot specify interrupt feeding.
- Another high-speed PTP positioning operation cannot be started while the PCU is starting a previous high-speed PTP positioning operation. Therefore, when using IOWR(223) to start high-speed PTP positioning, use a self-holding program structure with the Equals Flag so that IOWR(223) is executed every cycle until the positioning operation is started.

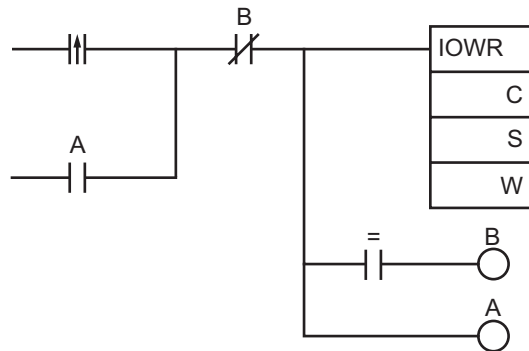

- When you execute the NCDMV(218) or IOWR(223) instruction, the execution result is saved in the Condition Flags. Use the Condition Flags, such as the Equals Flag, in input conditions that are branched from the same rung as the NCDMV(218) or IOWR(223) instruction.
- If you place a Condition Flag after a different instruction, the Condition Flag may change according to the execution result of the other instruction. Be sure to place any Condition Flags immediately after the NCDMV(218) or IOWR(223) instruction.

How High-speed PTP Start Instructions Are Processed

Starting high-speed PTP positioning causes the specified axis to be positioned during execution. However, if the high-speed PTP instruction is started consecutively, the time for executing the NCDMV(218) or IOWR(223) instruction will increase by 0.5 ms. This results in an increase in the PLC's cycle time.

Example: Starting high-speed PTP positioning consecutively for axes 1 to 3

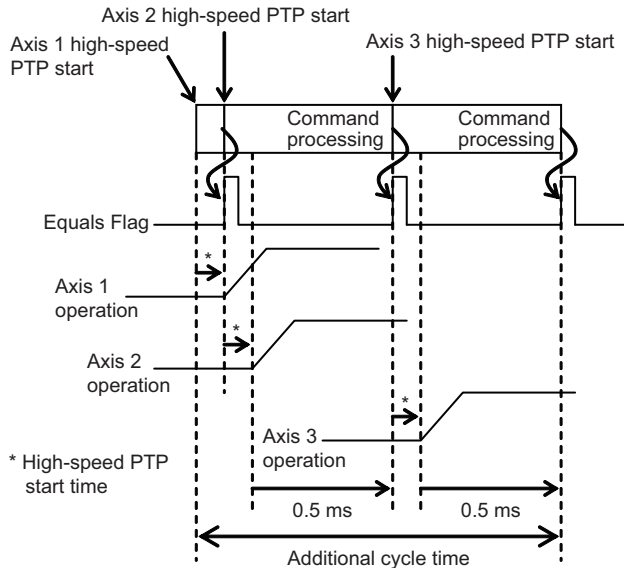

Although the high-Speed PTP positioning for axis 2 is executed immediately after the start of the high-Speed PTP positioning for axis 1, the time for executing the instruction increases by 0.5 ms. The high-Speed PTP positioning for axis 3 is executed after the completion of the high-Speed PTP positioning for axis 3 (that is, after a lapse of the time for executing the instruction).

Axis Status during High-speed PTP Positioning

When starting high-speed PTP positioning, reference output will start as soon as the instruction is executed. Updating axis status, such as the High-speed PTP Start Acknowledged Flag, will be performed in the next I/O refresh period.

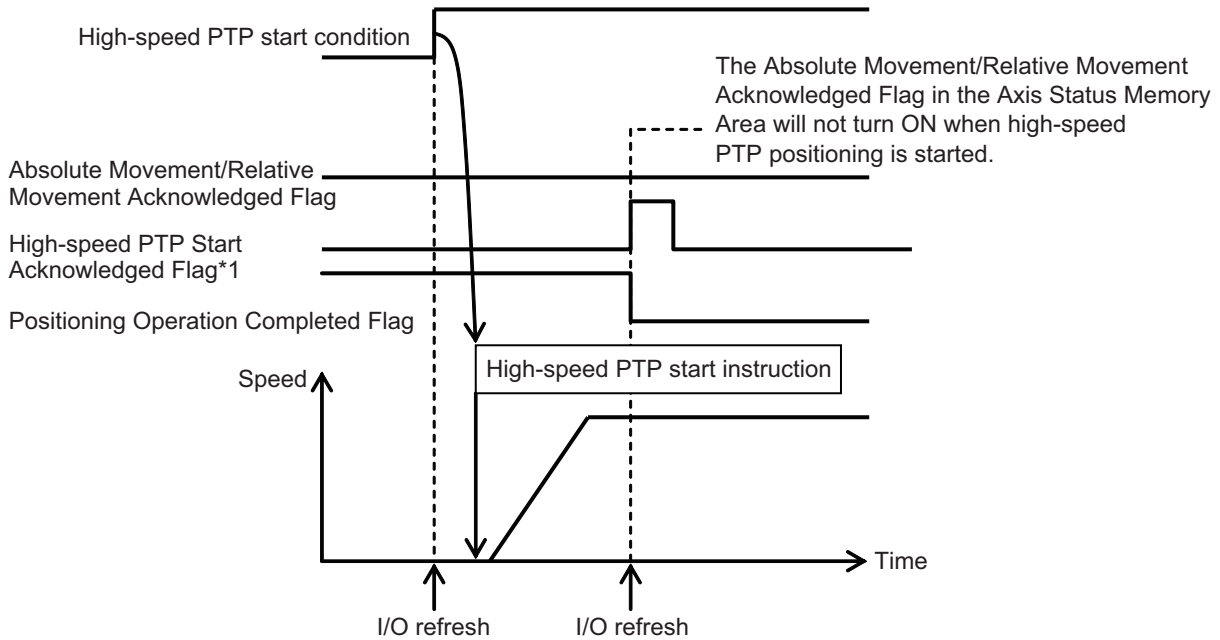

*1 The High-speed PTP Start Acknowledged Flag will turn ON for at least one cycle from the I/O refresh period immediately after the PCU acknowledges the High-speed PTP Start Bit. This flag also shows the response status for a high-speed PTP start command. It can therefore turn ON more than one cycle after the flags that indicate axis operating status, such as the Axis Busy Flag.

7-6 Example of Acceleration/ Deceleration Operation

The operation time for the acceleration time and deceleration time that are specified in the Direct Operation Command Memory Area is determined by the setting of the Acceleration/ Deceleration Time Selection axis parameter.

If 0 (constant acceleration/deceleration rate) is set for the Interpolation Acceleration/ Deceleration Time Selection parameter, the acceleration time will be the time from the starting speed to the maximum speed set in the axis parameters, and the deceleration time will be the time from the maximum speed to the starting speed.

If you specify 1 (Time Specification), the acceleration time and deceleration time are the times required to reach the target speed from the present speed.

7

Calculation of Basic Acceleration/Deceleration Time

This section describes the acceleration time and deceleration time when the Acceleration/ Deceleration Time Selection parameter is set to 0 (acceleration/deceleration rate specification).

Acceleration time $T1$ and deceleration time $T2$ are determined by the following formulas:

$$\text{Acceleration time } T1 = (V1 - V0) / (Vmax - V0) \times Ta$$

$$\text{Deceleration time } T2 = (V1 - V0) / (Vmax - V0) \times Td$$

- ◆ Parameters: The following two axis parameters are used.
 - ◆ Maximum Speed: $Vmax$ (pps)
 - ◆ Starting Speed: $V0$ (pps)
- ◆ Data: The following four values are specified in the Direct Operation Output Command Memory Area.
 - ◆ Command Position
 - ◆ Command Speed: $V1$ (pps)
 - ◆ Acceleration Time: Ta (ms)
 - ◆ Deceleration Time: Td (ms)

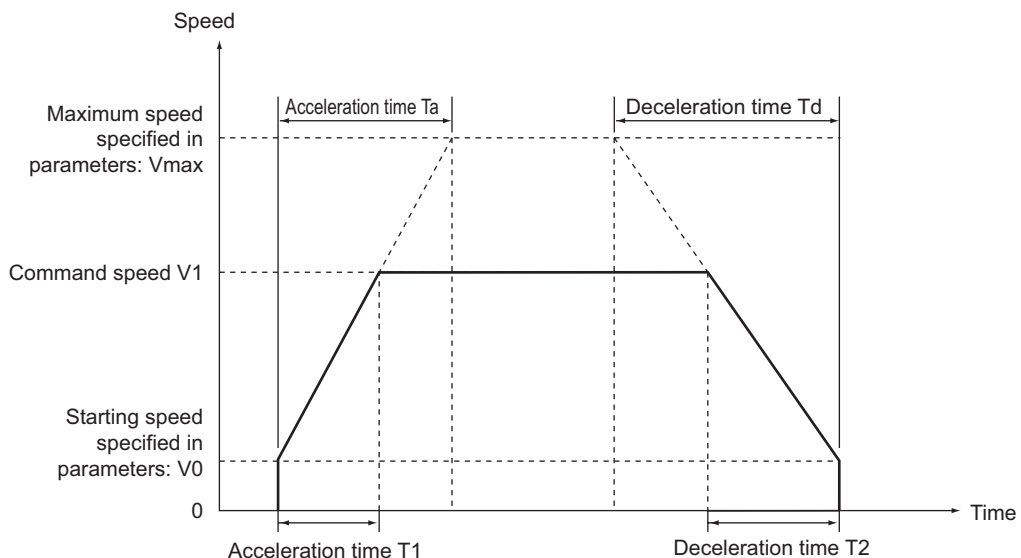

7-6 Example of Acceleration/ Deceleration Operation



Precautions for Correct Use

- ◆ The command speed is calculated as follows when an override is enabled:
Command speed = Command speed in Direct Operation Command Memory Area ×
Override in Manual Operation Command Memory Area/100

Calculation of Acceleration/Deceleration Time for Multi-starting

If you changed the command position or command speed during direct operation, the acceleration time and deceleration time are calculated as follows.

7

Command Speed Higher Than Present Speed

Acceleration time $T1 = (V1 - V0)/(Vmax - V0) \times Ta$

Acceleration time $T2 = (V2 - V1)/(Vmax - V0) \times Ta$

Deceleration time $T3 = (V2 - V0)/(Vmax - V0) \times Td$

- ◆ Parameters: The following two axis parameters are used.

- ◆ Maximum Speed: $Vmax$ (pps)
- ◆ Starting Speed: $V0$ (pps)

- ◆ Data: The following five values are specified in the operation data area.

First Command

- ◆ Command Position
- ◆ Command Speed: $V1$ (pps)
- ◆ Acceleration Time: Ta (ms)
- ◆ Deceleration Time: Td (ms)

Command to Change the Speed

- ◆ Command Speed: $V2$ (pps)

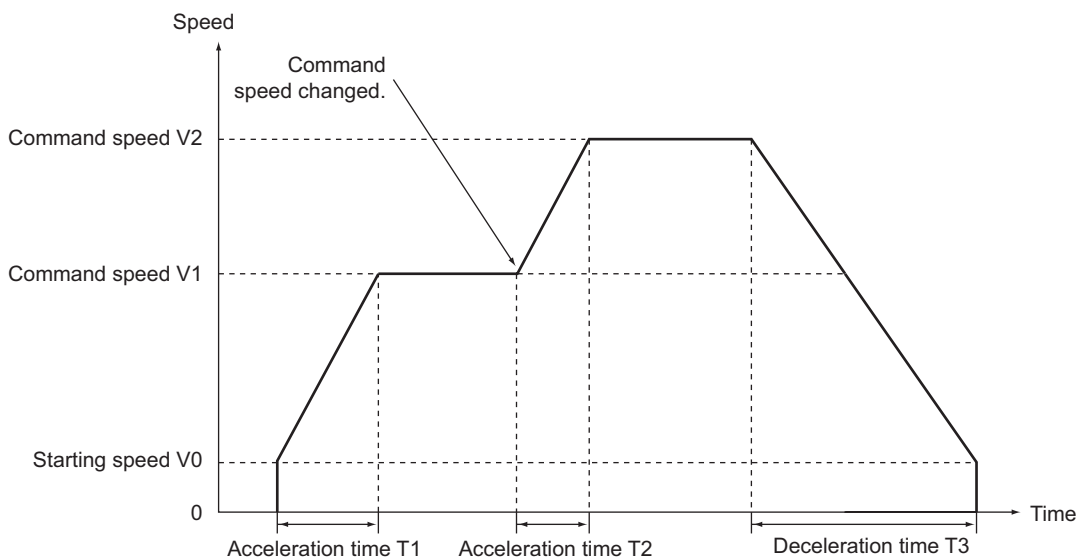

Command Speed Lower Than Present Speed

In this case ($V1 > V2$), only the calculation of $T2$ among the formulas above changes as follows:

$$\text{Deceleration time } T2 = (V1 - V2)/(V_{\text{max}} - V0) \times Td$$

Acceleration/Deceleration Operation with Short Movement

If the movement is too short relative to the command speed, the acceleration time, or the deceleration time when you start an axis, it may not be possible to achieve the acceleration/ deceleration curves specified for the command. Perform the acceleration/deceleration operation as specified below if the movement is too short.

Command Speed Higher Than Present Speed

If positioning is started when the axis is stationary or when the command speed is higher than the present speed, the shorter the movement, the shorter the constant-speed section becomes. If the movement is even shorter, acceleration and deceleration are performed to a lower speed and the specified acceleration and deceleration rates (slopes) are maintained.

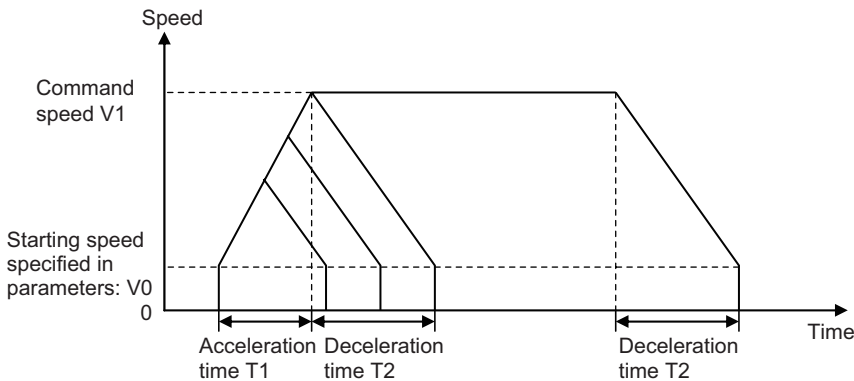

Command Speed Lower Than Present Speed

If the command speed is lower than the present speed, e.g., if you change the command position by multi-starting during direct operation, the shorter the movement, the shorter the constant-speed section becomes. If the movement is even shorter, deceleration is performed with a shorter deceleration time.

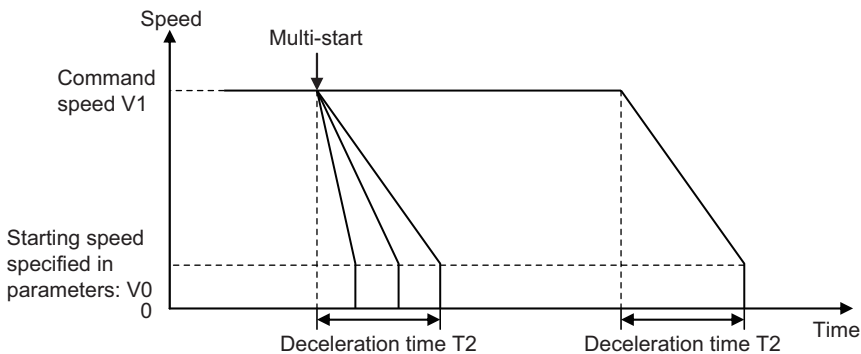

Multi-starting with Fixed Acceleration/Deceleration Time

When you use multi-starting during direct operation and change the command speed so that it is lower than the present speed, the deceleration curve changes as shown below if the positioning operation that was multi-started does not have a constant-speed section for the command speed.

When Changed Speed Is One-half of Starting Speed or Lower

If the changed speed is equal to or less than half the difference between the starting speed and the command speed (as shown by the following formula),

$$V2 \leq \frac{V1 - V0}{2}$$

the operation will be one of the following two patterns, depending on the movement distance.

When Deceleration at Step 1 Is Possible:

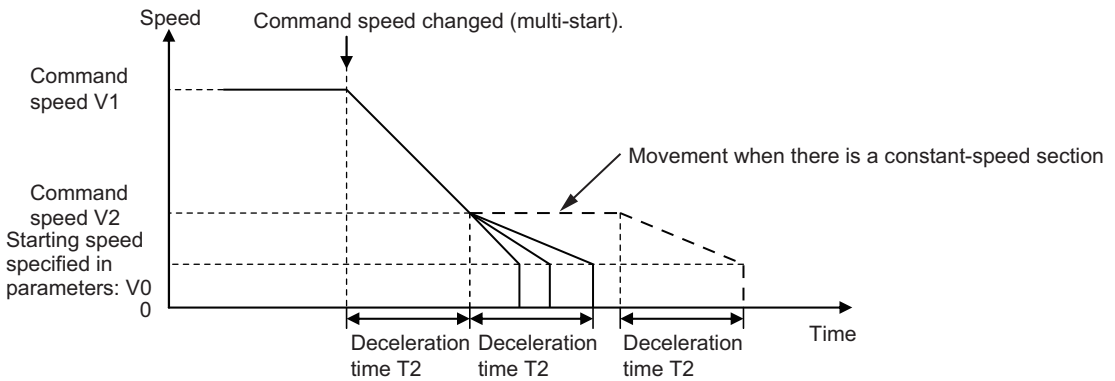

First, the axis decelerates to command speed V2 over deceleration time T2. When the movement distance is short and it would exceed the specified distance if the axis decelerates over deceleration time T2, the deceleration time changes according to the movement distance. In other words, the axis decelerates over a time that is shorter than the specified deceleration time.

When Deceleration at Step 1 Is Not Possible:

If the specified movement distance is even shorter than the movement distance shown above and the specified movement distance would be exceeded if deceleration was performed with deceleration time T2, the following operation is performed.

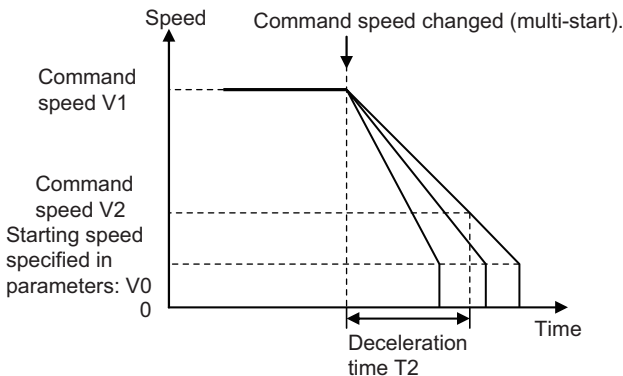

The axis starts decelerating to a stop based on the movement distance specified when multi-starting is implemented.



Reference

If deceleration is not possible at step 1 and the time from multi-starting to stopping would exceed 250 seconds, the stopping time will always be 250 seconds.

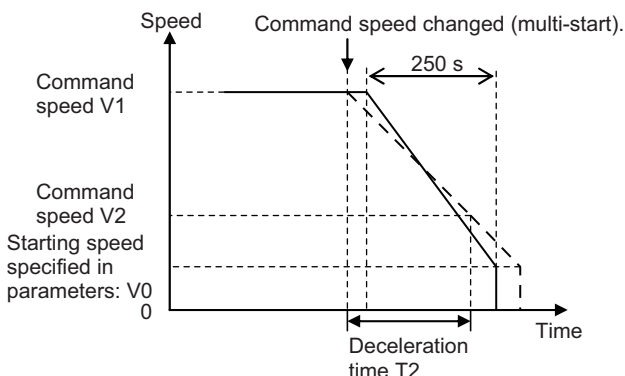

With a fixed deceleration time of 250 seconds, the axis does not decelerate immediately when you implement multi-starting and the movement distance is adjusted by using the constant-speed section.

When Changed Speed Exceeds One-half of Starting Speed

If the changed speed is more than half the difference between the starting speed and the command speed (as shown by the following formula),

$$V2 > \frac{V1 - V0}{2}$$

the operation will be one of the following two patterns.

When Deceleration at Step 1 Is Possible:

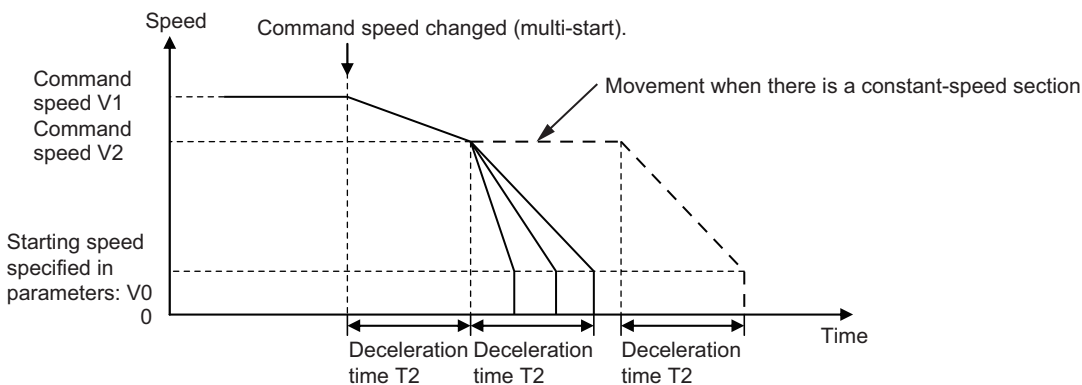

First, the axis decelerates to command speed V2 over deceleration time T2. When the movement distance is short and it would exceed the specified distance if the axis decelerates over deceleration time T2, the deceleration time changes according to the movement distance. In other words, the axis decelerates over a time that is shorter than the specified deceleration time.

7-6 Example of Acceleration/ Deceleration Operation

When Deceleration at Step 1 Is Not Possible:

If the specified movement distance is even shorter than the movement distance shown above and the specified movement distance would be exceeded if deceleration was performed with deceleration time T_2 , the following operation is performed.

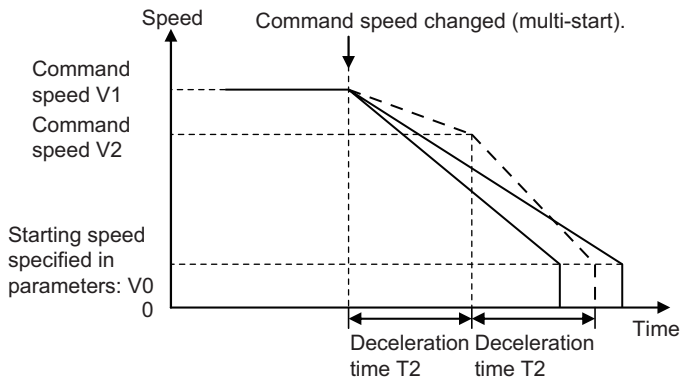

The axis starts decelerating to a stop based on the movement distance specified when multi-starting is implemented.

The stopping time may become longer than 2-step deceleration depending on the specified distance.



Reference

If deceleration is not possible at step 1 and the time from multi-starting to stopping would exceed 250 seconds, the stopping time will always be 250 seconds.

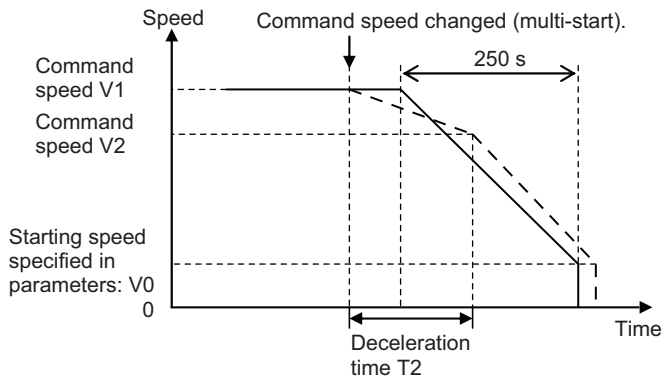

With a fixed deceleration time of 250 seconds, the axis does not decelerate immediately when you implement multi-starting and the movement distance is adjusted by using the constant-speed section.

7-7 Programming Example

This section shows programming examples in which the axis is started for the operation specified below.

Axis 1 is used as an example.



Precautions for Correct Use

- In this programming example, only the necessary parameters are changed and the default values are used for the rest of the parameters. The operation below may not be achieved if you change any other parameters.

Description of Operation

Set the mechanical configuration and machine movement as described below.

Mechanical Configuration

- Set the encoder resolution to 2,000 pulses/rotation.
- Use a Servomotor with a rated speed of 3,000 r/min.
- The workpiece advances by 10 mm per motor rotation.
- Use mm as the unit and execute commands in units of 0.01 mm.

Machine Movement

- Position axis 1 to 150.00 mm at a speed of 250 mm/s using a relative movement.
- Set the maximum speed to 500 mm/s (3,000 r/min).
- Set both the acceleration time and deceleration time to 0.2 s and set constant acceleration.
- To use a Servomotor, set the starting speed to 0.
- The Manual Operation Command Memory Area starts at W000, the Direct Operation Command Memory Area starts at W010, and the Axis Status Memory Area starts at W060.*1
- Do not change the speed by using an override.

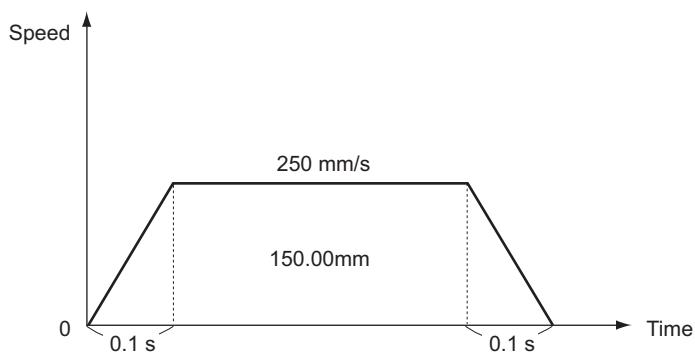

*1. When using an Eight-axis Unit (CJ1W-NC881), set the first word of each area so that the areas do not overlap.

Parameter Settings

The required parameters are changed according to the operation.
 Parameter changes are made only for axis 1.

Changing of Common Parameters

Here, settings are made for three areas: the Manual Operation Command Memory Area, Direct Operation Command Memory Area, and Axis Status Memory Area. For details on common parameters, refer to 6-3 *Common Parameters* on page 6-15.

Settings in the Manual Operation Command Memory Area

Set the first word of the Manual Operation Command Memory Area to W000.

When you set this area in the common parameters, the Manual Operation Command Memory Area will be allocated as shown below.

Word	Name	Bit	Bit name
W000	Axis 1 Manual Operation Command Bits	0	Servo Lock Bit
		1	Drive Alarm Reset Bit
		2	Deviation Counter Reset Bit
		3	Forward Torque Limit Bit
		4	Reverse Torque Limit Bit
		5	Override Enable Bit
		6	Jogging/Inching Speed Selection Bit
		7	Forward Jogging/Inching Bit
		8	Reverse Jogging/Inching Bit
		9	Not used.
		10	Origin Search Bit
		11	Origin Return Bit
		12	Not used.
		13	Immediate Stop Bit
14	Deceleration Stop Bit		
15	Servo Unlock Bit		
W001	Axis 1 Override	0 to 15	—

Direct Operation Command Memory Area

Set the first word in the Direct Operation Output Command Memory Area to W010.

When you set this area in the common parameters, the Direct Operation Command Memory Area will be allocated as shown below.

Word	Name	Bit	Bit name
W010	Axis 1 Direct Operation Command Bits	0	Absolute Movement Bit
		1	Relative Movement Bit
		2	Speed Control Bit
		3 to 4	Not used.
		5	Interrupt Feeding Specification Bit
		6	Interrupt Input Mask/ Present Position Latch Enable Bit
		7	Present Position Preset Bit
		8 to 14	Not used.
		15	Latch Completed Flag Clear Bit
W012	Axis 1 Command Position (lower word)	0 to 15	-
W013	Axis 1 Command Position (upper word)	0 to 15	
W014	Axis 1 Command Speed (lower word)	0 to 15	-
W015	Axis 1 Command Speed (upper word)	0 to 15	
W018	Axis 1 Acceleration Time (lower word)	0 to 15	-
W019	Axis 1 Acceleration Time (upper word)	0 to 15	
W020	Axis 1 Deceleration Time (lower word)	0 to 15	-
W021	Axis 1 Deceleration Time (upper word)	0 to 15	

Axis Status Memory Area

Set the first word in the Axis Status Memory Area to W060.

When you set this area in the common parameters, the Axis Status Memory Area will be allocated as shown below.

Word	Name	Bit	Bit name
W060	Axis 1 Manual Operation Command Acknowledged Flags	0	Servo Lock Acknowledged Flag
		1	Drive Alarm Reset Acknowledged Flag
		2	Deviation Counter Reset Acknowledged Flag
		3	Forward Torque Limit Acknowledged Flag
		4	Reverse Torque Limit Acknowledged Flag
		5	Override Enable Acknowledged Flag

7-7 Programming Example

7

Direct Operation

Word	Name	Bit	Bit name
W060 (continued)	Axis 1 Manual Operation Command Acknowledged Flags	6	Jogging/Inching Speed Selection Acknowledged Flag
		7	Forward Jogging/Inching Acknowledged Flag
		8	Reverse Jogging/Inching Acknowledged Flag
		9	Not used.
		10	Origin Search Acknowledged Flag
		11	Origin Return Acknowledged Flag
		12	Not used.
		13	Immediate Stop Acknowledged Flag
		14	Deceleration Stop Acknowledged Flag
W061	Axis 1 Direct Operation Command Acknowledged Flags	0	Absolute Movement Acknowledged Flag
		1	Relative Movement Acknowledged Flag
		2	Speed Control Acknowledged Flag
		3 to 4	Not used.
		5	Interrupt Feeding Specification Acknowledged Flag
		6	Interrupt Input Mask/Present Position Latch Enable Acknowledged Flag
		7	Present Position Preset Acknowledged Flag
		8 to 14	Not used.
W062	Axis 1 Command Status	15	Latch Completed Flag Clear Acknowledged Flag
		0	Axis Busy Flag
		1	Jogging Enabled Flag
		2	Direct Operation Enabled Flag
		3	Not used.
		4	Stop Input Flag
		5 to 6	Not used.
		7	High-speed PTP Start Acknowledged Flag
		8	Start Invalid Flag
		9	Deviation Counter Reset Invalid Flag
		10 to 11	Not used.
		12	Stop Executed Flag
		13	Positioning Operation Completed Flag
14 to 15	Not used.		

Word	Name	Bit	Bit name
W063	Axis 1 Axis Operation Command Status	0	Servo Unlocked Flag
		1	Servo Locked Flag
		2	Not used.
		3	Acceleration Flag
		4	Constant Speed Flag
		5	Deceleration Flag
		6	Pass Flag
		7	Positioning Completed Waiting Flag
		8	Deceleration Stop Flag
		9	Immediate Stop Flag
		10 to 15	Not used.
W064	Axis 1 Operation Status	0	Origin Search Flag
		1	Origin Return Flag
		2	Not used.
		3	Jogging/Inching Flag
		4	Absolute Movement Flag
		5	Relative Movement Flag
		6	Speed Control Flag
		7	Interrupt Feeding (Interrupt Input Waiting) Flag
		8	Interrupt Feeding (Feeding) Flag
		9 to 10	Not used.
		11	Memory Operation Flag
		12 to 15	Not used.
		W065	Axis 1 Control Status
1	Stopped at Origin Flag		
2	Latch Completed Flag		
3	Not used.		
4	Command Present Position Overflow Flag		
5	Command Present Position Underflow Flag		
6	Feedback Present Position Overflow Flag		
7	Feedback Present Position Underflow Flag		
8	Sensor Error Flag		
9	Servo Error Flag		
10	Execution Error Flag		
11	Axis Warning Flag		
12	Axis Error Flag		
13	Zone 0 Flag		
14	Zone 1 Flag		
15	Zone 2 Flag		

Word	Name	Bit	Bit name
W066	Axis 1 External I/O Status	0	Servo ON Flag
		1	Alarm Reset Output Flag
		2	Deviation Counter Reset Output Flag
		3	Forward Torque Limit Output Flag
		4	Reverse Torque Limit Output Flag
		5	Main Circuit Status Flag
		6	Servo Drive Warning Flag
		7	Servo Ready Flag
		8	Forward Limit Input Flag
		9	Reverse Limit Input Flag
		10	Origin Proximity Input Flag
		11	Origin Input Flag
		12	Interrupt Input Flag
		13	Emergency Stop Input Flag
		14	Positioning Completed Input Flag
15	Drive Alarm Input Flag		
W067	Axis 1 Error Code	0 to 15	–
W068	Axis 1 Command Present Position (lower word)	0 to 15	–
W069	Axis 1 Command Present Position (upper word)	0 to 15	
W070	Axis 1 Expanded Monitor (lower word)	0 to 15	–
W071	Axis 1 Expanded Monitor (upper word)	0 to 15	

Changing Axis Parameters

First, change the Command Position Unit Setting parameter. For details, refer to *Command Position Unit Setting* on page 6-40.

Set the parameters as follows according to the mechanical configuration.

Parameter name	Function	Set value	Unit
Displayed Unit	Select the unit for command values. 0: pulses, 1: mm, 2: degrees, 3: inches	1	–
Command Pulses Count Per Motor Rotation	Set the number of pulses per motor rotation.	2000	Pulses
Work Travel Distance Per Motor Rotation	Set the amount of workpiece movement per motor rotation.	10	Displayed Unit [mm]

Parameter name	Function	Set value	Unit
Unit Multiplier	Set the ratio relative to the amount of the work-piece movement when the motor makes 1 rotation. 0: x1, 1: x10, 2: x100, 3: x1,000, 4: x10,000	2*1	–

*1. This setting sets 0.01 mm as the command unit.

Next, change the acceleration/deceleration settings. For details, refer to *Acceleration/Deceleration Settings* on page 6-36.

Similarly, set the following parameters according to the mechanical configuration.

Parameter name	Function	Set value	Unit
Maximum Speed	Specify the maximum speed for the axis.	50,000	Command units/s (0.01 mm/s)
Starting Speed	Specify the starting speed for the axis.	0	Command units/s (0.01 mm/s)
Acceleration/Deceleration Time Selection	Set how to specify the acceleration/deceleration time. 0: Time from starting speed to maximum speed of each axis (constant acceleration/deceleration rate) 1: Time from present speed to target speed of each axis (constant acceleration/deceleration time)	0	–



Precautions for Correct Use

- Because the maximum speed was changed to 500.00 mm/s, the default values for the origin search speed, jogging/inching speed, and other speed-related parameters may exceed the maximum speed. For those parameters that exceed the maximum speed, set the values to the maximum speed or lower.

Program Example

This example shows how to set the Direct Operation Memory Area and operate the PCU.

Data Settings

Although an override parameter is provided in the Manual Operation Command Memory Area, it is not used in this example. Do not change the default setting.

Set the position data, speed data, acceleration time, and deceleration time in the Direct Operation Output Command Memory Area.

Words	Name	Contents of setting	
W012	Axis 1 Command Position (lower word)	The position data is 150 mm. Since you set the unit to 0.01 mm, the set value is 15,000. Set this as 3A98 hex.	3A98 hex
W013	Axis 1 Command Position (upper word)		0000 hex
W014	Axis 1 Command Speed (lower word)	The same goes with the speed data. Since you set the unit to 0.01 mm for 250 mm/s, the set value is 25,000. Set this as 61A8 hex.	61A8 hex
W015	Axis 1 Command Speed (upper word)		0000 hex
W018	Axis 1 Acceleration Time (lower word)	The unit for the acceleration time is ms. To set an acceleration time of 0.2 s, the set value is 200 ms. Set this as 00C8 hex.	00C8 hex
W019	Axis 1 Acceleration Time (upper word)		0000 hex
W020	Axis 1 Deceleration Time (lower word)	The unit for the deceleration time is ms. To set a deceleration time of 0.2 s, the set value is 200 ms. Set this as 00C8 hex.	00C8 hex
W021	Axis 1 Deceleration Time (upper word)		0000 hex

Ladder Programming

The following figure shows the programming for a relative movement.

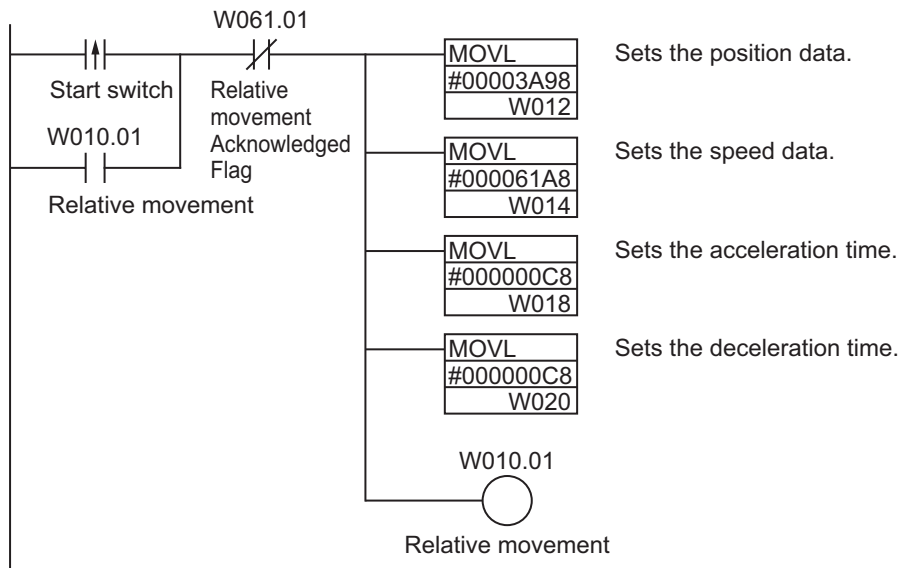

Programming Examples for Starting High-speed PTP Positioning

Programming examples are given below that rewrite the above programming using IOWR(223) and NCDMV(218).

Ladder Programming Using NCDMV(218)

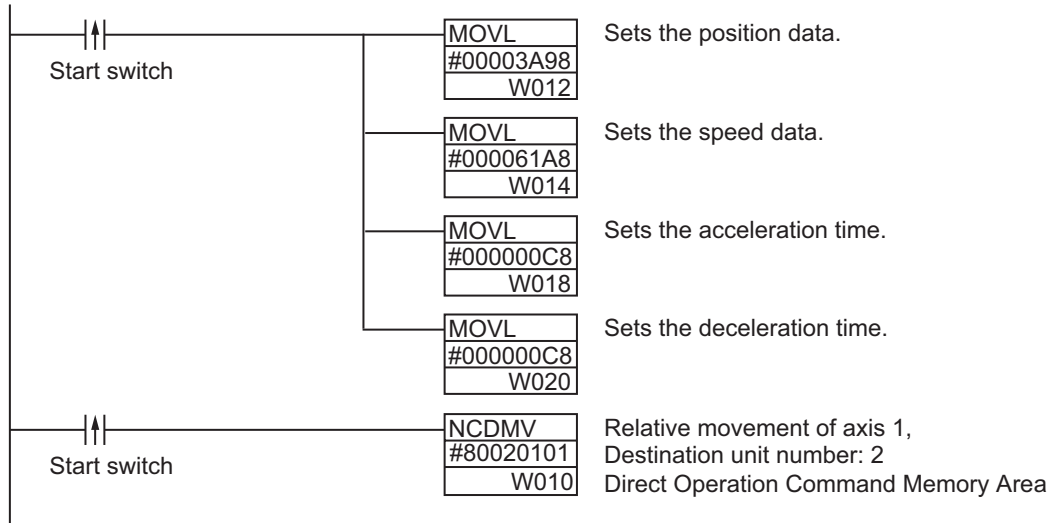

Ladder Programming Using IOWR(223)

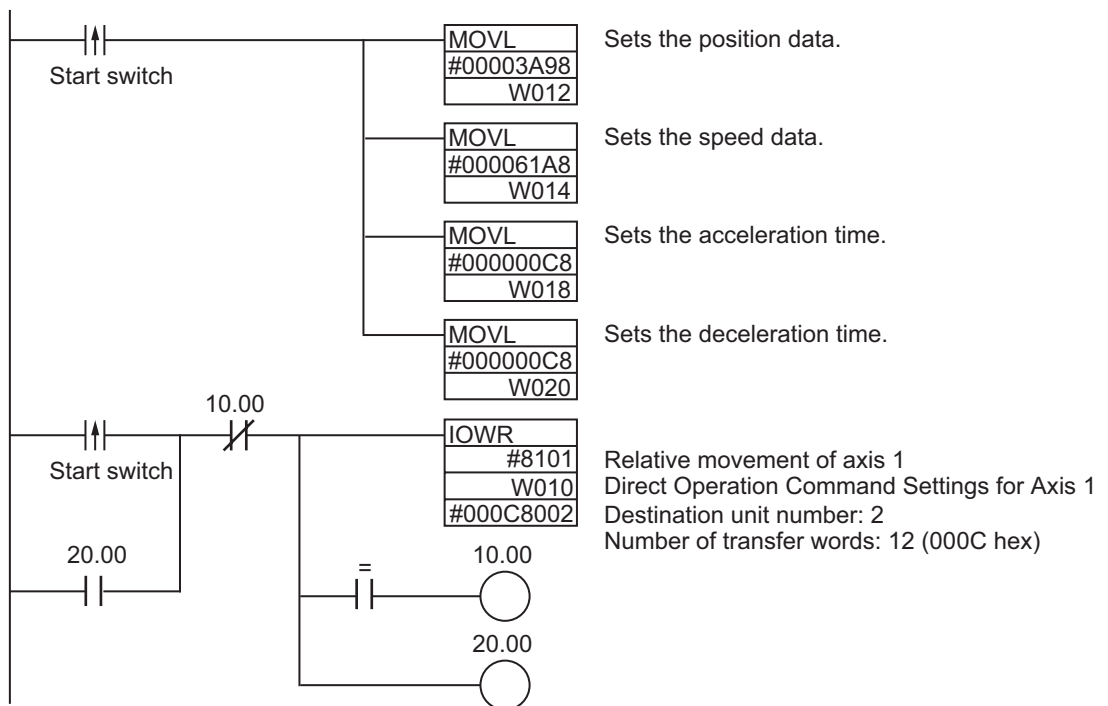

7-8 Monitoring with CX-Programmer

You can monitor direct operation by using the CX-Programmer.

This section describes the monitoring procedure.

1. Connect the CX-Programmer online to the PLC.
2. Display the PCU Setting Window.
3. Select Monitor from the NC Unit Menu.

The following window will be displayed.

Monitor - New Unit [Unit Model: CJ1W-NCF82 Unit No.1]

PCU Status
PCU Ready **ON**

Axis Selection
Axis1 Axis2 Axis3 Axis4
Physical Physical Physical Physical

Present Position

Axis	Command Position	Feedback Position	Pulse
Axis1	0	0	Pulse
Axis2	0	0	Pulse
Axis3	0	0	Pulse
Axis4	0	0	Pulse

Axis Status

	Axis1	Axis2	Axis3	Axis4
Busy	OFF	OFF	OFF	OFF
Stop Execution	OFF	OFF	OFF	OFF
Positioning Operation Completed	OFF	OFF	OFF	OFF
Origin Established	OFF	OFF	OFF	OFF
Origin Stop	OFF	OFF	OFF	OFF
Servo Unlock	ON	OFF	OFF	OFF
Forward Limit Input	OFF	OFF	OFF	OFF
Reverse Limit Input	OFF	OFF	OFF	OFF
Origin Proximity Input	OFF	OFF	OFF	OFF
Origin Input	OFF	OFF	OFF	OFF
Zone0	OFF	OFF	OFF	OFF
Zone1	OFF	OFF	OFF	OFF
Zone2	OFF	OFF	OFF	OFF
Origin Proximity Input Internal Memory Area	OFF	OFF	OFF	OFF

Error Information

PCU	Axis1	Axis2	Axis3	Axis4
ERR 0004	ERR 00A9	0000	0000	0000
Link Off Error	Axis Communications Error			

Status | I/O | Present Value

Axis Operation	Axis1	Axis2	Axis3
Origin Search	OFF	OFF	OFF
Origin Return	OFF	OFF	OFF
Jogging/Inching	OFF	OFF	OFF
Absolute Movement	OFF	OFF	OFF
Relative Movement	OFF	OFF	OFF
Speed Control	OFF	OFF	OFF
Interrupt Input Waiting	OFF	OFF	OFF
Interrupt Feeding	OFF	OFF	OFF
Memory Operation	OFF	OFF	OFF
Synchronous Feeding (Trq)	OFF	OFF	OFF
Synchronous Feeding (Vel)	OFF	OFF	OFF
Synchronous Feeding (Pos)	OFF	OFF	OFF

4. Select the axis you want to monitor.
5. Click the Status, I/O, or Present Value Tab to monitor the desired data.

8

Memory Operation

This section describes the procedures, memory data settings, operation methods, and other information required to perform memory operation in combination with an OMNUC G5-series Servo Drive.

8-1	Outline of Memory Operation	8-1
8-2	Memory Operation Data Settings	8-6
8-3	Memory Operation	8-24
8-4	Linear Interpolation	8-50
8-5	Circular Interpolation.....	8-53
8-6	Timing Charts.....	8-55
8-7	Acceleration/Deceleration.....	8-60
8-8	Programming Example.....	8-64
8-9	Monitoring with CX-Programmer.....	8-78
8-10	Memory Operation Preview.....	8-7953

8-1 Outline of Memory Operation

With memory operation, positioning is performed sequentially based on commands from the PLC using memory operation data that was set in advance in the PCU.

 **Precautions for Correct Use**

Direct operation can be used only when the Position Control Unit is used together with an OMNUC G5-series Servo Drive.

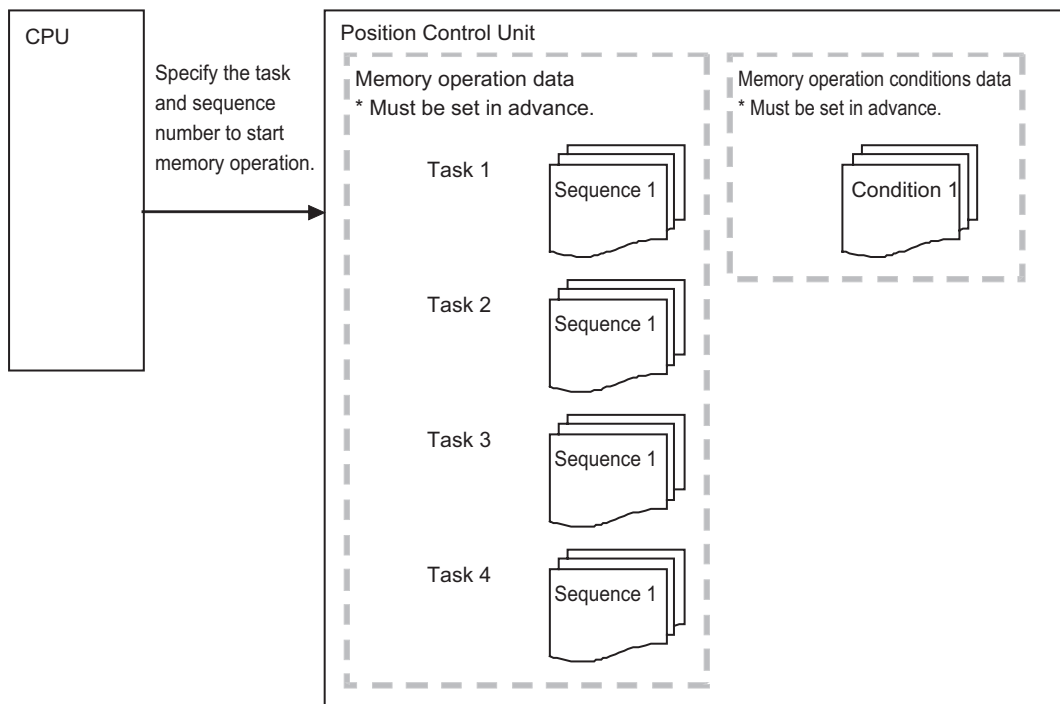

Memory operation is controlled in units of execution called tasks.

The PCU can execute up to 4 tasks simultaneously.

The axes that are controlled by the tasks are set in the memory operation parameters.

You do not need to allocate all axes to a task, but you cannot allocate the same axis to more than one task.

Configuration Axes for Memory Operation

Depending on the model, the PCU can control up to sixteen axes with memory operation. However, a maximum of four tasks can be used regardless of the number of axes and each task can control a maximum of four axes.

The configuration axes for one task are set in the Configuration Axis parameter in the memory operation parameters. Up to four of the controlled axes can be set, but the same axis cannot be set in more than one task.

The relation between the configuration axes in a task and the physical axis is shown below for the selected axis numbers.

Selecting Axes 1 to 4

Memory operation parameters			Task 1	Task 2	Task 3	Task 4
Task 1 configuration axes	Axis 4	Configuration axis 1	–	Axis 1	–	–
Task 2 configuration axes	Axes 1 and 2	Configuration Axis 2	–	Axis 2	–	–
Task 3 configuration axes	Axis 3	Configuration Axis 3	–	–	Axis 3	–
Task 4 configuration axes	Not defined.	Configuration Axis 4	Axis 4	–	–	–

Selecting Axis 5 or Higher

In tasks that contain axis 5 or higher, the numbers of axes set as configuration axes are treated in ascending order as configuration axes 1 to 4 (maximum).

Memory operation parameters			Task 1	Task 2	Task 3	Task 4
Task 1 configuration axes	Axes 4, 6, and 8	Configuration axis 1	Axis 4 ^{*1}	Axis 1 ^{*1}	–	Axis 7 ^{*1}
Task 2 configuration axes	Axes 1, 2, and 5	Configuration Axis 2	Axis 6 ^{*1}	Axis 2 ^{*1}	–	–
Task 3 configuration axes	Axis 3	Configuration Axis 3	Axis 8 ^{*1}	Axis 5 ^{*1}	Axis 3 ^{*2}	–
Task 4 configuration axes	Axis 7	Configuration Axis 4	–	–	–	–

*1. If a task contains axis 5 or higher, the numbers of axes set as configuration axes are treated in ascending order as configuration axes. The configuration axes numbers are always used in order from 1.

*2. All axes used in the task are between 1 and 4, so the configuration axis number is the same as the axis number.



Reference

- ◆ Up to two tasks can be set for the CJ1W-NC281 and up to four tasks can be set for the CJ1W-NC481/881/F81/482/882/F82.
- ◆ In each task, the command and command values in the memory operation data apply to the axis that corresponds to the configuration axis number.
- ◆ Position data that is stored when teaching is performed is also stored as data according to the configuration axes.

Setting Configuration Axes

The configuration axes are set in the memory operation parameters.

The configuration axis settings are enabled when the power supply is turned ON, when the PCU is restarted, or when the PCU Setup Bit is turned ON.

Parameter name	Function	Setting range	Unit	Default value
Configuration Axes ^{*1}	Select the configuration axes for the task. Bit 00: Turn ON to use axis 1. Otherwise turn OFF. Bit 01: Turn ON to use axis 2. Otherwise turn OFF. Bit 02: Turn ON to use axis 3. Otherwise turn OFF. Bit 03: Turn ON to use axis 4. Otherwise turn OFF. Bit 04: Turn ON to use axis 5. Otherwise turn OFF. Bit 05: Turn ON to use axis 6. Otherwise turn OFF. Bit 06: Turn ON to use axis 7. Otherwise turn OFF. Bit 07: Turn ON to use axis 8. Otherwise turn OFF. Bit 08: Turn ON to use axis 9. Otherwise turn OFF. Bit 09: Turn ON to use axis 10. Otherwise turn OFF. Bit 10: Turn ON to use axis 11. Otherwise turn OFF. Bit 11: Turn ON to use axis 12. Otherwise turn OFF. Bit 12: Turn ON to use axis 13. Otherwise turn OFF. Bit 13: Turn ON to use axis 14. Otherwise turn OFF. Bit 14: Turn ON to use axis 15. Otherwise turn OFF. Bit 15: Turn ON to use axis 16. Otherwise turn OFF.	0000 to F000 hex	–	0

*1. Up to four axes can be selected for one task. An error will occur if more than four axes are selected.



Precautions for Correct Use

- ◆ You cannot set an axis that is already in use for other task.
- ◆ The configuration axes are set only when using an OMNUC G5-series Servo Drive.
- ◆ The numbers of axes that are set are treated in ascending order as configuration axes 1 to 4 (maximum) in memory operation.

Memory Operation Data

Memory operation data consists of sequences. One sequence consists of the following settings: Command, Sequence Start Condition, Sequence Skip Condition, End Pattern, and Positioning Completed Input Monitor Valid.

The PCU has Memory Operation Data for each task. Each task can contain up to 500 sequences. Also, the Memory Operation Data can also include up to 100 conditions in the Memory Operation Condition Data. This data can be referenced as condition data from any of the tasks.

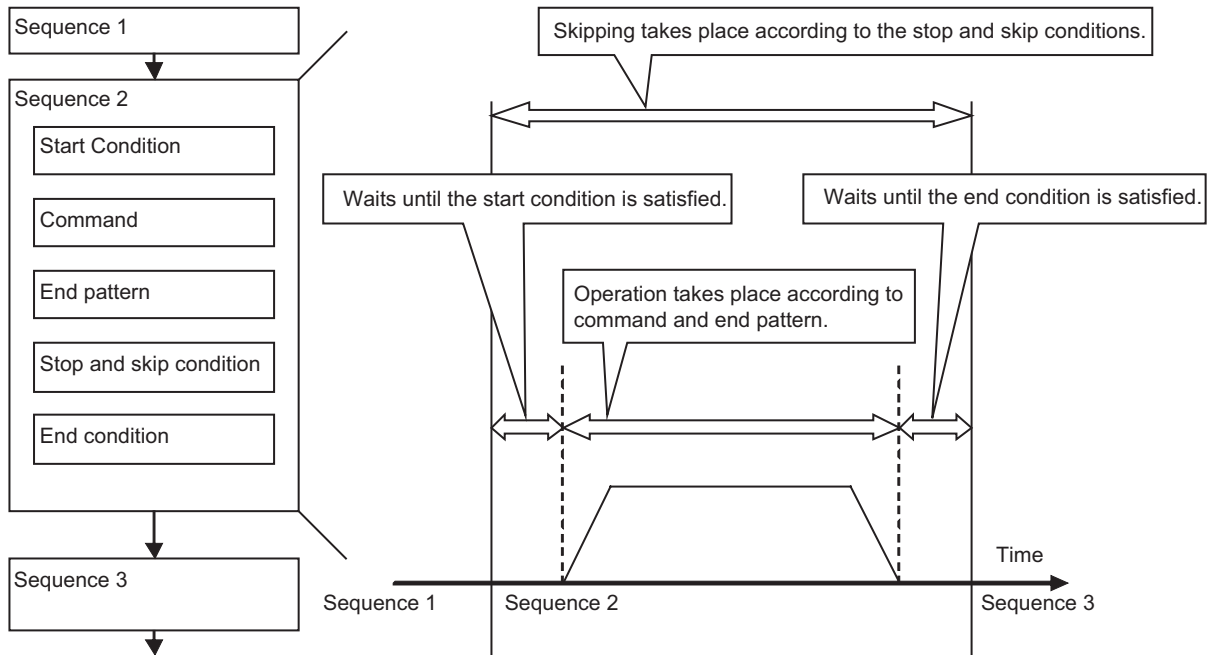

Memory Operation Procedure

This section describes the procedure to perform memory operation. It is assumed that the EtherCAT communications setup has been completed.

1. Common Parameter Settings

To perform memory operation, the following four areas must be used: Manual Operation Command Memory Area, Axis Status Memory Area, Memory Operation Command Memory Area, and Memory Operation Status Memory Area.

For information on setting these areas, refer to *6-3 Common Parameters* on page 6-15.

2. Axis Parameter Settings

Settings are also made in the Axis Parameters, including the Acceleration/Deceleration Settings and Output Settings.

For information on the axis parameters, refer to *6-4 Axis Parameters* on page 6-29.

3. Memory Operation Parameter Settings

Set the axis configuration of each task, the operation for errors in interpolated axes, and other memory operation parameters.

For information on the memory operation parameters, refer to *6-5 Memory Operation Parameters* on page 6-71.

4. Memory Operation Data Settings

Set the sequence data. You can set up to 500 sets of sequence data for each task.

For information on the memory operation data, refer to *6-7 Memory Operation Data* on page 6-147.

5. Memory Operation Condition Data Settings

Set the conditions for sequence data. You can set 100 conditions for use by any of the tasks.

For information on the memory operation condition data, refer to *6-8 Memory Operation Condition Data* on page 6-163.

6. Transferring Data

Transfer the common parameters, axis parameters, and memory operation parameters to the PCU.

7. Saving Data

Save the data to the flash memory in the PCU.

8. Restarting the PCU

9. Put the Servo Drive in operating status.

10. Execute an origin search.

11. Starting Memory Operation

Set the sequence number of the operation you want to use in the Memory Operation Command Memory Area for each task, and then turn ON the Sequence Number Enable Bit.

Operation will start when the Memory Operation Start Bit is turned ON.

Operation is started separately for each task.



Reference

- ♦ The sequence number is incremented automatically. Once the execution of sequence 1 has been completed, the Executing Sequence Number stored in memory automatically changes to indicate sequence 2.
- ♦ When END is executed as the command, the sequence number returns to the one that was effective when you turned ON the Sequence Number Enable Bit.

8-2 Memory Operation Data Settings

The operation sequences, positions, speeds, acceleration time, deceleration time, and other parameters for memory operation are set as Memory Operation Data.

You can register up to 500 sequences per task as Memory Operation Data.

You can also set 100 conditions as Memory Operation Condition Data for use by any task.

For the setting methods and other details on common parameter, refer to 6-3 *Common Parameters* on page 6-15. For information on axis parameters and memory operation parameters, refer to 6-4 *Axis Parameters* on page 6-29 and 6-5 *Memory Operation Parameters* on page 6-71.

Memory Operation Data List

Each sequence includes the following data. However, you do not need to set all of the data depending on the data attributes. For details, refer to *Command* on page 8-25.

Data name	Function	Setting range	Unit	Default value
Configuration Axis 1 Command Position	Set the command position for configuration axis 1.	-2,147,483,648 to 2,147,483,647	Command units	0
Configuration Axis 2 Command Position	Set the command position for configuration axis 2.	-2,147,483,648 to 2,147,483,647	Command units	0
Configuration Axis 3 Command Position	Set the command position for configuration axis 3.	-2,147,483,648 to 2,147,483,647	Command units	0
Configuration Axis 4 Command Position	Set the command position for configuration axis 4.	-2,147,483,648 to 2,147,483,647	Command units	0
Command	0000 hex: No sequence data 8### hex: NOP (Treated as a comment.) Sequence Commands 0001 hex: JUMP 0002 hex: FOR 0003 hex: NEXT 0004 hex: PSET 0005 hex: PRSET 004F hex: END Operation Commands 0800 hex: Positioning 0801 hex: Linear interpolation 0802 hex: Clockwise circular interpolation 0803 hex: Counterclockwise circular interpolation 081E hex: Speed control 081F hex: Interrupt feeding for positioning 0820 hex: Interrupt feeding for speed control			0

8-2 Memory Operation Data Settings

Data name	Function	Setting range	Unit	Default value
Jump/Repeat Condition	Set the memory operation condition data number for JUMP and FOR. 0: Execute unconditionally 1 to 100: Memory operation condition data number	0 to 100	—	0
Jump Destination Sequence Number	Set the sequence number to jump to.	1 to 500	—	0
Repeat Loop Number	Set a number to pair the FOR and NEXT commands.	0 to 49	—	0
Output Signal	Specify the destination of the forced output. 0000 hex: No output ##03 hex: Forward torque limit output ##04 hex: Reverse torque limit output ##: 01 to 04 (Indicate configuration axes, 01: Configuration axis 1, 02: Configuration axis 2, 03: Configuration axis 3, 04: Configuration axis 4) 8000 to 800F hex: Memory Operation Auxiliary Area (8,000 to 800F hex correspond to bits 00 to 15, respectively.)			0
Sequence Start Condition	Set the start condition. 0: No start condition 1 to 100: Memory operation condition data number	0 to 100	—	0
Sequence Skip Condition	Set the stop/skip condition. 0: No stop/skip condition 1 to 100: Memory operation condition data number	0 to 100	—	0
End Pattern	Set the operation end pattern. 0: Individual 1: Automatic 2: Continuous 1 (Until the next sequence speed) 3: Continuous 2 (Acceleration/deceleration starts at the next sequence) 4: Continuous 3 (Pass: Overlap deceleration for the present sequence and acceleration for the next sequence)	0 to 4	—	0
Dwell Timer	If the end pattern is set to Individual or Automatic, set the dwell time. 0: No dwell time 1 to 1000: Dwell time	0 to 1,000	10 ms	0
Positioning Completed Input Monitor Valid	Select the positioning completed operation to use when an axis stops. 0: Do not wait for the completion of positioning 1: Wait for the completion of positioning	0 to 1	—	0
M Code	Set the M code for after positioning has been completed. 0: No M code 1 to 499: M codes that wait to be reset 500 to 999: M codes that do not wait to be reset	0 to 999	—	0

Data name	Function	Setting range	Unit	Default value
Axis Specification	Set the axes to start. Bit 00: Configuration axis 1 Bit 01: Configuration axis 2 Bit 02: Configuration axis 3 Bit 03: Configuration axis 4 A start command is sent when each bit turns ON.	0 to F	–	0
Position Specification	Select whether to use a relative position or absolute position for the command position. Turn OFF a bit to indicate an absolute position. Bit 00: Configuration axis 1 Bit 01: Configuration axis 2 Bit 02: Configuration axis 3 Bit 03: Configuration axis 4	0 to F	–	0
Interpolation Speed* ¹	Set the interpolation speed.	1 to 2,147,483,647	Command units/s	0
Interpolation Acceleration Time	Set the interpolation acceleration time.	0 to 250,000	ms	0
Interpolation Deceleration Time	Set the interpolation deceleration time.	0 to 250,000	ms	0
Interpolation Starting Speed* ¹	Set the interpolation starting speed.	0 to 2,147,483,647	Command units/s	0
Interpolation Acceleration/Deceleration Curve Selection	Select the curve for interpolation acceleration/deceleration. 0: Trapezoid, 1: S-curve (tertiary curve)	0 to 1	–	0
Interpolation Acceleration/Deceleration Time Selection	Select the specification method for the interpolation acceleration/deceleration time. 0: Time from starting speed to maximum speed of each axis (constant acceleration/deceleration rate) 1: Time from present speed to target speed of each axis (constant acceleration/deceleration time)	0 to 1	–	0
Configuration Axis 1 Circular Center/ Passing Point Position	Set the center position of the arc if the center point was selected for the Circular Interpolation Method. Set the passing point position on the arc if the passing point selected for the Circular Interpolation Method.	-2,147,483,648 to 2,147,483,647	Command units	0
Configuration Axis 2 Circular Center/ Passing Point Position		-2,147,483,648 to 2,147,483,647	Command units	0
Configuration Axis 3 Circular Center/ Passing Point Position		-2,147,483,648 to 2,147,483,647	Command units	0
Configuration Axis 4 Circular Center/ Passing Point Position		-2,147,483,648 to 2,147,483,647	Command units	0

8-2 Memory Operation Data Settings

Data name	Function	Setting range	Unit	Default value
Circular Radius	Set the circular radius if the radius was selected for the Circular Interpolation Method.	-2,147,483,648 to 2,147,483,647	Command units	0
Configuration Axis 1 Rotation Axis Direction	If you select a rotation axis in the applicable axis parameter, select the operating direction for positioning (PTP) for an absolute movement designation. 0: Shortest route 1: Forward 2: Reverse 3: Not specified	0 to 3	–	0
Configuration Axis 2 Rotation Axis Direction		0 to 3	–	0
Configuration Axis 3 Rotation Axis Direction		0 to 3	–	0
Configuration Axis 4 Rotation Axis Direction		0 to 3	–	0
Configuration Axis 1 Command Speed ^{*2}	Set the target speed of each axis in positioning operation (PTP) and speed control.	-2,147,483,648 to 2,147,483,647	Command units/s	0
Configuration Axis 2 Command Speed ^{*2}	The command range is 1 to 2,147,483,647 for positioning, and -2,147,483,648 to 2,147,483,647 for speed control.	-2,147,483,648 to 2,147,483,647	Command units/s	0
Configuration Axis 3 Command Speed ^{*2}		-2,147,483,648 to 2,147,483,647	Command units/s	0
Configuration Axis 4 Command Speed ^{*2}		-2,147,483,648 to 2,147,483,647	Command units/s	0
Configuration Axis 1 Acceleration Time		Set the acceleration time in positioning operation (PTP) and speed control.	0 to 250,000	ms
Configuration Axis 2 Acceleration Time	0 to 250,000		ms	0
Configuration Axis 3 Acceleration Time	0 to 250,000		ms	0
Configuration Axis 4 Acceleration Time	0 to 250,000		ms	0
Configuration Axis 1 Deceleration Time	Set the deceleration time in positioning operation (PTP) and speed control.	0 to 250,000	ms	0
Configuration Axis 2 Deceleration Time		0 to 250,000	ms	0
Configuration Axis 3 Deceleration Time		0 to 250,000	ms	0
Configuration Axis 4 Deceleration Time		0 to 250,000	ms	0
Interpolation Speed Specification Method	Select the Interpolation Speed Specification Method for linear interpolation. 0: Specify the interpolation path speed. 1: Specify the maximum speed.	0 to 1	–	0

Data name	Function	Setting range	Unit	Default value
Error Enable for Undetected Interrupt Input	Select whether to output an error when an interrupt input is not received before positioning is completed during interrupt feeding for position control. 0: Without error detection 1: With error detection	0 to 1	–	0
Interrupt Feeding Amount	Set the amount of movement in interrupt feeding.	-2,147,483,648 to 2,147,483,647	Command units	0

*1. The setting is made in command units/s. The speed set in the Maximum Speed parameter is the upper limit for each axis during interpolation.

*2. The setting is made in command units/s, but if the setting is converted to pulses, 1 to 104,857,600 pps cannot be exceeded for PTP positioning and -104,857,600 to 104,857,600 cannot be exceeded for speed control.

Memory Operation Condition Data List

Each condition data set includes the following settings. You do not need to set all data depending on the condition data. For details, refer to *Details of Memory Operation Condition Data* on page 6-165.

Parameter name	Function	Setting range	Unit	Default value
Condition	Set the comparison condition. 0000 hex: Condition data not yet set 0010 hex: ON (bit comparison) 0011 hex: OFF (bit comparison) 0012 hex: AND (bit comparison) 0013 hex: OR (bit comparison) 0020 hex: = (data comparison: 2 words) 0021 hex: ≠ (data comparison: 2 words) 0022 hex: ≥ (data comparison: 2 words, signed) 0023 hex: ≤ (data comparison: 2 words, signed) 0030 hex: Timer (time specification) 0040 hex: Counter (count specification) The following can be specified only for sequence start conditions. 0101 hex: Configuration axis 1 external interrupt input 0102 hex: Configuration axis 2 external interrupt input 0103 hex: Configuration axis 3 external interrupt input 0104 hex: Configuration axis 4 external interrupt input 0200 hex: Start with command			0
Edge Selection	Select how to evaluate the conditional expression. 0: Level assessment 1: Edge assessment	0 to 1	–	0

8-2 Memory Operation Data Settings

Parameter name	Function	Setting range	Unit	Default value
Data 1 Area Selection	Specify the data 1 area for comparison. 0: PCU Control Memory Area (Output/Input) 1: Manual Operation Command Memory Area (Output) 2: Direct Operation Command Memory Area (Output) 3: Memory Operation Command Memory Area (Output) 4: Axis Status Memory Area (Input) 5: Memory Operation Status Memory Area (Input) 6: Expanded Monitor Memory Area (Input) F: Constant (You can set a constant for either comparison data 1 or data 2, but not both.)	0 to 5, 000F hex	–	0
Data 1 Word Offset	Specify the word position as the offset from the first word of the target area that you specified for the Data 1 Area Selection. This will be the first word for data comparison.	0 to 255	–	0
Data 1 Bit	Specify the bit position in the target word that you specified for the Data 1 Area Selection and Data 1 Word Offset. This setting is enabled only for the bit comparison.	0 to 15	–	0
Data 2 Area Selection	Specify the data 2 area for comparison. 0: PCU Control Memory Area (Output/Input) 1: Manual Operation Command Memory Area (Output) 2: Direct Operation Command Memory Area (Output) 3: Memory Operation Command Memory Area (Output) 4: Axis Status Memory Area (Input) 5: Memory Operation Status Memory Area (Input) 6: Expanded Monitor Memory Area (Input) F: Constant (You can set a constant for either comparison data 1 or data 2, but not both.)	0 to 5, 000F hex	–	0
Data 2 Word Offset	Specify the word position as the offset from the first word of the target area that you specified for the Data 2 Area Selection. This will be the first word for data comparison.	0 to 255	–	0
Data 2 Bit	Specify the bit position in the target word that you specified for the Data 2 Area Selection and Data 2 Word Offset. This setting is enabled only for the bit comparison.	0 to 15	–	0
Timer	Set the time to be applied when you specify a timer for the conditional expression.	0 to 1,000	10 ms	0
Counter	Specify the count to be applied when you specify a counter for the conditional expression.	0 to 10,000	times	0
Constant	Set the constant when the condition is data comparison and a constant is specified for data 1 or data 2.	-2,147,483,648 to 2,147,483,647	–	0



Precautions for Correct Use

The specified reference data (word or constant data) that is used in data comparison for memory operation condition data is treated as signed 32-bit binary data. If the specified reference data is not signed 32-bit binary data, correct comparison results may not be achieved. Check the results of comparison operations sufficiently before using the data as data comparison conditions.

For example, if a GX-series Remote I/O Terminal Encoder Input Slave (GX-EC02□1) is connected, the Encoder Input Slave will input the present position, latch position, or other data as unsigned 32-bit data. The Position Control Unit, however, would treat this data as signed 32-bit data in the comparison operations, so any data that exceeds 31 bits (2,147,483,648 to 4,294,967,295) will be treated as two's complements (-2,147,483,648 to -1).

Therefore, you must make sure that the values in conditional expressions for memory operation condition data comparison do not exceed 31 bits before you set the data.



Reference

The Data 1 Word Offset, Data 1 Bit, Data 2 Word Offset, and Data 2 Bit can be set by selecting the axis number and bit name from the PCU Setup Window on the CX-Programmer.

Memory Area Words and Bits Used in Memory Operation

This section describes the memory area words and bits used in memory operation. Axis 1 and task 1 are used as examples.

Manual Operation Command Memory Area

This area contains command bits, such as the Servo Lock Bit and Origin Search Bit.

For information on the setting method for the Manual Operation Command Memory Area, refer to *Manual Operation Command Memory Area Selection* on page 6-17.

The following table lists the memory allocations when you set the First Word of Manual Operation Command Memory Area parameter to word "A."

Words	Name	Bit	Bit name	Function
A	Axis 1 Manual Operation Command Bits	0	Servo Lock Bit	Turn ON this bit to lock the servo.
		1	Drive Alarm Reset Bit	Turn ON this bit to reset the Servo Drive alarm.
		2	Deviation Counter Reset Bit	Turn ON this bit to reset the deviation counter.
		3	Forward Torque Limit Bit	Use this bit to enable or disable the forward torque limit. ON: Enabled, OFF: Disabled
		4	Reverse Torque Limit Bit	Use this bit to enable or disable the reverse torque limit. ON: Enabled, OFF: Disabled
		5	Override Enable Bit	Specify whether to enable or disable an override.
		6	Jogging/Inching Speed Selection Bit	Select the jogging/inching speed. Turn OFF this bit to select speed 1 and turn ON this bit to select speed 2.
		7	Forward Jogging/Inching Bit	Turn ON this bit to perform jogging or inching in the forward direction.
		8	Reverse Jogging/Inching Bit	Turn ON this bit to perform jogging or inching in the reverse direction.
		9	Not used.	Do not use.
		10	Origin Search Bit	Turn ON this bit to start an origin search.
		11	Origin Return Bit	Turn ON this bit to start an origin return.
		12	Not used.	Do not use.
		13	Immediate Stop Bit	Turn ON this bit to start performing an immediate stop.
		14	Deceleration Stop Bit	Turn ON this bit to start performing a deceleration stop.
15	Servo Unlock Bit	Turn ON this bit to unlock the servo.		
A+1	Axis 1 Override	0 to 15	–	Set the override in hexadecimal. You can set any value from 1 to 50,000 (0001 to C350 hex), which correspond to 0.01% to 500.00%.

Axis Status Memory Area

This area is used to confirm the axis status, such as axis busy and positioning operation completed status. For information on the setting method for the Axis Status Memory Area, refer to *Axis Status Memory Area Selection* on page 6-19.

The following table shows the allocations when the First Word in the Axis Status Memory Area parameter is set to word "C."

Words	Name	Bit	Bit name	Function
C	Axis 1 Manual Operation Command Acknowledged Flags	0	Servo Lock Acknowledged Flag	This flag turns ON to acknowledge the Servo Lock Bit.
		1	Drive Alarm Reset Acknowledged Flag	This flag turns ON to acknowledge the Drive Alarm Reset Bit.
		2	Deviation Counter Reset Acknowledged Flag	This flag turns ON to acknowledge the Deviation Counter Reset Bit.
		3	Forward Torque Limit Acknowledged Flag	This flag turns ON to acknowledge the Forward Torque Limit Bit.
		4	Reverse Torque Limit Acknowledged Flag	This flag turns ON to acknowledge the Reverse Torque Limit Bit.
		5	Override Enable Acknowledged Flag	This flag turns ON to acknowledge the Override Enable Bit.
		6	Jogging/Inching Speed Selection Acknowledged Flag	This flag turns ON to acknowledge the Jogging/Inching Speed Selection Bit.
		7	Forward Jogging/Inching Acknowledged Flag	This flag turns ON to acknowledge the Forward Jogging/Inching Bit.
		8	Reverse Jogging/Inching Acknowledged Flag	This flag turns ON to acknowledge the Reverse Jogging/Inching Bit.
		9	Not used.	Do not use.
		10	Origin Search Acknowledged Flag	This flag turns ON to acknowledge the Origin Search Bit.
		11	Origin Return Acknowledged Flag	This flag turns ON to acknowledge the Origin Return Bit.
		12	Not used.	Do not use.
13	Immediate Stop Acknowledged Flag	This flag turns ON to acknowledge the Immediate Stop Bit.		

8-2 Memory Operation Data Settings

Words	Name	Bit	Bit name	Function
C (continued)	Axis 1 Manual Operation Command Acknowledged Flags	14	Deceleration Stop Acknowledged Flag	This flag turns ON to acknowledge the Deceleration Stop Bit.
		15	Servo Unlock Acknowledged Flag	This flag turns ON to acknowledge the Servo Unlock Bit.
C+1	Axis 1 Direct Operation Command Acknowledged Flags	0	Absolute Movement Acknowledged Flag	This flag turns ON to acknowledge the Absolute Movement Bit.
		1	Relative Movement Acknowledged Flag	This flag turns ON to acknowledge the Relative Movement Bit.
		2	Speed Control Acknowledged Flag	This flag turns ON to acknowledge the Speed Control Bit.
		3 to 4	Not used.	Do not use.
		5	Interrupt Feeding Specification Acknowledged Flag	This flag turns ON to acknowledge the Interrupt Feeding Specification Bit.
		6	Interrupt Input Mask/Present Position Latch Enable Acknowledged Flag	This flag turns ON to acknowledge the Interrupt Input Mask/Present Position Latch Enable Bit.
		7	Present Position Preset Acknowledged Flag	This flag turns ON to acknowledge the Present Position Preset Bit.
		8	Synchronous Feeding Position Acknowledged Flag ^{*1}	This flag turns ON to acknowledge the Synchronous Feeding Position Bit.
		9	Synchronous Feeding Velocity Acknowledged Flag ^{*1}	This flag turns ON to acknowledge the Synchronous Feeding Velocity Bit.
		10	Synchronous Feeding Torque Acknowledged Flag ^{*1}	This flag turns ON to acknowledge the Synchronous Feeding Torque Bit.
		11	Origin Position Latch Enable Acknowledged Flag ^{*1}	This flag turns ON to acknowledge the Origin Position Latch Enable Bit.
		12 to 13	Not used.	Do not use.
		14	Origin Position Latch Clear Acknowledged Flag ^{*1}	This flag turns ON to acknowledge the Origin Position Latch Completed Flag Clear Bit.

Words	Name	Bit	Bit name	Function
C+1 (continued)	Axis 1 Direct Operation Command Acknowledged Flags	15	Latch Completed Flag Clear Acknowledged Flag	This flag turns ON to acknowledge the Latch Completed Flag Clear Bit.
C+2	Axis 1 Command Status	0	Axis Busy Flag	This flag turns ON during axis operation. During memory operation, the Busy Flags for axes that are not assigned in the axis configuration will turn ON even if there is no axis operation.
		1	Jogging Enabled Flag	This flag turns ON when jogging can be started.
		2	Direct Operation Enabled Flag	This flag turns ON when direct operation can be started.
		3	Not used.	Do not use.
		4	Stop Input Flag	This flag will turn ON when the Immediate Stop Bit or the Deceleration Stop Bit is acknowledged or when the emergency stop input or deceleration input is received. Other start command bits will not be acknowledged while this flag is ON.
		5	Synchronous Group Stop Input Flag ^{*1}	This flag turns ON when the Synchronous Group Stop Bit in synchronized data is acknowledged and the system is stopped and when the Synchronous Group Stop Bit is ON.
		6	All Synchronized Unit Stop Input Flag ^{*1}	This flag turns ON when the All Synchronized Unit Stop Bit in synchronized data is acknowledged and the system is stopped and when the All Synchronized Unit Stop Bit is ON.
		7	High-speed PTP Start Acknowledged Flag	This flag turns ON to acknowledge a high-speed PTP start.
		8	Start Invalid Flag	This flag turns ON when an axis command could not be acknowledged.
		9	Deviation Counter Reset Acknowledged Flag	This flag turns ON when the Deviation Counter Reset Bit could not be acknowledged.
		10 to 11	Not used.	Do not use.
		12	Stop Executed Flag	This flag turns ON when axis operation has stopped for one of the following reasons during manual operation or direct operation. <ul style="list-style-type: none"> Stopping when a deceleration stop is executed, the deviation counter is reset, or the servo is unlocked Stopping when an error occurs
		13	Positioning Operation Completed Flag	This flag turns ON when positioning, an origin search, or an origin return has been finished in direct operation or when jogging is stopped in direct operation.
14 to 15	Not used.	Do not use.		

8-2 Memory Operation Data Settings

Words	Name	Bit	Bit name	Function
C+3	Axis 1 Axis Operation Status	0	Servo Unlocked Flag	This flag is ON while the servo is unlocked for the axis.
		1	Servo Locked Flag	This flag is ON when the axis is stopped in servo lock status.
		2	Not used.	Do not use.
		3	Acceleration Flag	This flag is ON while the axis is accelerating to the target speed. This flag can also be used for path status during interpolation.
		4	Constant Speed Flag	This flag is ON while the axis is moving at a constant speed after reaching the target speed. This flag can also be used for path status during interpolation.
		5	Deceleration Flag	This flag is ON while the axis is decelerating to the target position or to the target speed. This flag can also be used for path status during interpolation.
		6	Pass Flag	This flag is ON during acceleration/ deceleration to the target speed of the next sequence for the continuous 1 or continuous 3 operation patterns. This flag can also be used for path status during interpolation.
		7	Positioning Completed Waiting Flag	This flag is ON while waiting for axis positioning to be completed. This flag can also be used for path status during interpolation.
		8	Deceleration Stop Flag	This flag is ON until the axis stops for a deceleration stop during axis operation.
		9	Immediate Stop Flag	This flag is ON until the axis stops for an immediate stop during axis operation.
		10 to 15	Not used.	Do not use.
C+4	Axis 1 Operation Status	0	Origin Search Flag	This flag is ON during an origin search operation.
		1	Origin Return Flag	This flag is ON during an origin return operation.
		2	Not used.	Do not use.
		3	Jogging/Inching Flag	This flag is on during jogging or inching.
		4	Absolute Movement Flag	This flag is ON during an absolute movement. It is also ON until the interrupt feeding input is received.
		5	Relative Movement Flag	This flag is ON during a relative movement. It is also ON until the interrupt feeding input is received.
		6	Speed Control Flag	This flag is ON during speed control. It is also ON until the interrupt feeding input is received.
		7	Interrupt Feeding (Interrupt Input Waiting) Flag	This flag is ON during interrupt feeding until the interrupt input turns ON.

Words	Name	Bit	Bit name	Function
C+4 (continued)	Axis 1 Operation Status	8	Interrupt Feeding (Positioning) Flag	This flag is ON after the interrupt input turns ON during interrupt feeding.
		9 to 10	Not used.	Do not use.
		11	Memory Operation Flag	This flag is ON during memory operation.
		12	Not used.	Do not use.
		13	Synchronous Feeding Torque Flag ^{*1}	This flag is ON during synchronous feeding torque control operation. The axis movement reflects the command torque data stored in the Synchronous Data Link Memory Area.
		14	Synchronous Feeding Velocity Flag ^{*1}	This flag is ON during synchronous feeding velocity control operation. The axis movement reflects the command speed data stored in the Synchronous Data Link Memory Area.
		15	Synchronous Feeding Position Flag ^{*1}	This flag is ON during synchronous feeding position operation. The axis movement reflects the position data for the auxiliary axis that is set with the Electric Shaft function and stored in the Synchronous Data Link Memory Area.
C+5	Axis 1 Control Status	0	Origin Defined Flag	This flag is ON while the origin is defined. OFF: Origin not defined. ON: Origin defined.
		1	Stopped at Origin Flag	This flag is ON while the axis is stopped within the positioning completed width. It will not turn ON unless the origin is defined.
		2	Latch Completed Flag	This flag turns ON when the present position has been latched.
		3	Origin Position Latch Completed Flag ^{*1}	This flag turns ON when the origin position has been latched.
		4	Command Present Position Overflow Flag	This flag turns ON when an overflow occurs in the command position in Linear Mode.
		5	Command Present Position Underflow Flag	This flag turns ON when an underflow occurs in the command position in Linear Mode.
		6	Feedback Present Position Overflow Flag	This flag turns ON when an overflow occurs in the feedback position in Linear Mode.
		7	Feedback Present Position Underflow Flag	This flag turns ON when an underflow occurs in the feedback position in Linear Mode.
		8	Sensor Error Flag	This flag turns ON when an error is detected for an external sensor, such as for the emergency stop input or a limit input.
		9	Servo Error Flag	This flag turns ON when a Servo Drive alarm occurs.
		10	Execution Error Flag	This flag turns ON when an operation error occurs for an axis function.
		11	Axis Warning Flag	This flag turns ON when a warning occurs in memory operation.

8-2 Memory Operation Data Settings

Words	Name	Bit	Bit name	Function
C+5 (continued)	Axis 1 Control Status	12	Axis Error Flag	This flag turns ON when an axis error occurs.
		13	Zone 0 Flag	This flag is ON while the present position is in zone 0.
		14	Zone 1 Flag	This flag is ON while the present position is in zone 1.
		15	Zone 2 Flag	This flag is ON while the present position is in zone 2.
C+6	Axis 1 External I/O Status	0	Servo ON Flag	This flag is ON while power is being supplied to the Servomotor.
		1	Alarm Reset Output Flag	This flag turns ON when an alarm reset is output.
		2	Deviation Counter Reset Output Flag	This flag turns ON when a deviation counter reset is output.
		3	Forward Torque Limit Output Flag	This flag turns ON when a forward torque limit is output.
		4	Reverse Torque Limit Output Flag	This flag turns ON when a reverse torque limit is output.
		5	Main Circuit Status Flag	This flag turns ON when a voltage is supplied to the main circuits.
		6	Servo Drive Warning Input Flag	This flag turns ON when a Servo Drive warning occurs.
		7	Servo Ready Flag	This flag turns ON when the servo is ready.
		8	Forward Limit Input Flag	This flag is ON while the forward limit input is being received.
		9	Reverse Limit Input Flag	This flag is ON while the reverse limit input is being received.
		10	Origin Proximity Input Flag	This flag is ON while the origin proximity input is being received.
		11	Origin Input Flag	This flag is ON while the origin input is being received.
		12	Interrupt Input Flag	This flag is ON while the interrupt input is being received.
		13	Emergency Stop Input Flag	This flag is ON while the emergency input is being received.
		14	Positioning Completed Input Flag	This flag is ON while the axis is within the positioning completed width.
15	Drive Alarm Input Flag	This flag turns ON when a drive alarm occurs.		
C+7	Axis 1 Error Code	0 to 15	This word contains the axis error code.	
C+8	Axis 1 Command Present Position (lower word)	0 to 15	These words contain the present command position.	
C+9	Axis 1 Command Present Position (upper word)	0 to 15		

Words	Name	Bit	Bit name	Function
C+10	Axis 1 Expanded Monitor (lower word)	0 to 15		These words contain the monitor value that is specified by the Expanded Monitor Type axis parameter. For details, refer to <i>Expanded Monitor Settings</i> on page 6-59.
C+11	Axis 1 Expanded Monitor (upper word)	0 to 15		

*1. Available with version 1.3 or later PCUs.

Memory Operation Command Memory Area

This memory area is used to set the sequence number setting, enable the sequence number, start memory operation, and reset the M code.

For information on the setting the first word of the Memory Operation Command Memory Area, refer to *Memory Operation Command Memory Area Selection* on page 6-18.

The following table shows the allocations when the First Word in the Memory Operation Command Memory Area parameter is set to word "D."

Words	Name	Bit	Bit name	Function
D	Task 1 Memory Operation Command Bits	0	Sequence Number Enable Bit	Turn ON this bit to enable the sequence number set in the operation data area when memory operation starts.
		1	Memory Operation Start Bit	Turn ON this bit to start memory operation.
		2	Memory Operation Individual Start Bit	All sequences will be executed as independent operations, except when the command is set to END.
		3	Not used.	Do not use.
		4	M Code Reset Bit	Turn ON this bit to reset the M code.
		5	Teaching Bit	Turn ON this bit to perform teaching.
		6 to 14	Not used.	Do not use.
		15	Memory Operation Stop Bit	Turn ON this bit to decelerate memory operation to a stop.
D+1	Task 1 Sequence Number	0 to 15	Specify the starting sequence number for memory operation.	
D+2	Task 1 Teaching Address Number	0 to 15	Set the position data number (sequence number) to use for position teaching. Set the number in hexadecimal.	

Memory Operation Status Memory Area

This is the memory area to check the task status, such as memory operation busy flag and memory operation start permitted.

For information on the setting method for Memory Operation Status Memory Area, refer to *Memory Operation Status Memory Area Selection* on page 6-20.

The following table shows the allocations when the First Word in the Memory Operation Status Memory Area parameter is set to word "E."

Word	Name	Bit	Bit name	Function
E	Task 1 Memory Operation Command Acknowledged Flags	0	Sequence Number Enable Acknowledged Flag	This flag turns ON to acknowledge the Sequence Number Enable Bit.
		1	Memory Operation Start Acknowledged Flag	This flag turns ON to acknowledge the Memory Operation Start Bit.
		2	Memory Operation Individual Start Acknowledged Flag	This flag turns ON to acknowledge the Memory Operation Independent Start Bit.
		3	Not used.	Do not use.
		4	M Code Reset Acknowledged Flag	This flag turns ON to acknowledge the M Code Reset Bit.
		5	Teaching Acknowledged Flag	This flag turns ON to acknowledge the Teaching Bit.
		6 to 14	Not used.	Do not use.
		15	Memory Operation Stop Acknowledged Flag	This flag turns ON to acknowledge the Memory Operation Stop Bit.
E+1	Task 1 Memory Operation Command Status	0	Memory Operation Busy Flag	This flag is ON while a task command is being executed. It remains ON while a task configuration axis is busy or a task function is being executed.
		1	Memory Operation Start Enabled Flag	This flag is ON while a task can be started. It is OFF while a task configuration axis is busy or a task function is being executed.
		2 to 3	Not used.	Do not use.
		4	Memory Operation Stop Input Flag	This flag is ON while decelerating after receiving a memory operation stop command. Start commands will not be acknowledged while this flag is ON.
		5 to 7	Not used.	Do not use.
		8	Memory Operation Start Invalid Flag	This flag turns ON when an error, such as a memory operation multi-start error, occurs after execution of a command for memory operation due to an invalid execution condition or command value.

Word	Name	Bit	Bit name	Function
E+1 (continued)	Task 1 Memory Operation Command Status	9	Teaching Invalid Flag	This flag turns ON when the PCU could not acknowledge a teaching command.
		10 to 11	Not used.	Do not use.
		12	Memory Operation Stop Executed Flag	This flag turns ON when memory operation has stopped after receiving a memory operation stop command, after an error stop, or after receiving a command accompanied by a single-axis stop during memory operation.
		13	Memory Operation Completed Flag	This flag turns ON when memory operation has stopped normally.
		14	Teaching Completed Flag	This flag turns ON when a teaching command is completed.
		15	Not used.	Do not use.
E+2	Task 1 Memory Operation Control Status	0	Memory Operation Stopped Flag	This flag is ON while memory operation is not being executed.
		1	Memory Operation Waiting Flag	This flag is ON while memory operation is on standby. It turns ON when memory operation stops without executing END.
		2	Memory Operation Axis Operating Flag	This flag is ON while an axis is operating during memory operation. It is ON while any configuration axis is operating.
		3	Condition Input Waiting Flag	This flag is ON while the PCU is waiting for the input of conditions during memory operation.
		4	Dwell Timer Waiting Flag	This flag is ON while the PCU is waiting for the dwell time during memory operation.
		5	M Code Reset Waiting Flag	This flag is ON while the PCU is waiting for the M code to be reset during memory operation.
		6	M Strobe Flag	This flag is ON while there is an M code output during memory operation.
		7 to 9	Not used.	Do not use.
		10	Memory Operation Execution Error Flag	This flag turns ON when an operation error occurs for the task function.
		11	Memory Operation Warning Flag	This flag turns ON when a warning occurs in memory operation.
		12	Memory Operation Error Flag	This flag turns ON when a memory operation error occurs.
		13 to 15	Not used.	Do not use.
E+3	Task 1 Memory Operation Error Code	0 to 15	This word contains the task error code.	

8-2 Memory Operation Data Settings

Word	Name	Bit	Bit name	Function
E+4	Task 1 Executing Sequence Number	0 to 15		This word contains the number of the sequence that is being executed in memory operation.
E+5	Task 1 M Code	0 to 15		This word contains the M code (output code) for memory operation.

8-3 Memory Operation

This section describes memory operation.

Starting Memory Operation

The sequence number must be specified before starting memory operation.
There are two ways to start memory operation.

- (1) Turn ON the Memory Operation Bit.
- (2) Turn ON the Memory Operation Individual Start Bit.



Reference

- ◆ To perform memory operation for the first time, you must set the sequence number and turn ON the Sequence Number Enable Bit.
- ◆ The sequence number is cleared when any of the following bits is turned ON: Servo Lock, Origin Search, Origin Return, or Present Position Preset.
- ◆ An error will occur if you start memory operation without specifying a sequence number.
- ◆ To start memory operation from a sequence number that is different from the executing sequence number, you must set the sequence number and turn ON the Sequence Number Enable Bit again.

Memory Operation Start Bit

When you use the Memory Operation Start Bit to start memory operation, the next sequence number will be automatically executed after executing the starting sequence. Execution will continue until END is executed in a sequence data command.

If the end pattern is set to Individual, however, operation will stop temporarily. To execute the next sequence number, you must turn ON the Memory Operation Start Bit again.

If a JUMP command to another sequence number or a FOR to NEXT loop does not occur until sequence 500, the system will assume that END has been executed after sequence 500.

Also, an error will occur if you have not set a sequence number when memory operation is started.

Memory Operation Individual Start Bit

When you use the Memory Operation Individual Start Bit to start memory operation, all operations are performed as if the end patterns were set to Individual, regardless of sequence data.

Use the Memory Operation Individual Start Bit to debug sequences one at a time.

The operation that is set for the specified sequence number is executed, the Executing Sequence Number is updated in memory based on the execution result, and then the operation ends.

Use the Memory Operation Start Bit for normal operation.

Command

The command determines the attributes of each sequence.

There are two types of command data: data with sequence attributes and data with operation attributes.

Sequence Commands

Sequence commands have the following two functions.

- ♦ Function to branch and repeat sequences according to the control conditions during continuous operation.
- ♦ Function to forcibly turn ON or OFF the bit information to be output to the CPU Unit and outside the PCU.

For information on the memory operation condition data, refer to *6-8 Memory Operation Condition Data* on page 6-163.

NOP

Sequences with a NOP command are treated as comments.

Nothing happens and the sequence number changes to the next one.

JUMP

JUMP is used for sequence data for a JUMP command.

If you set JUMP for the command, you can set the four types of sequence data given below.

Data name	Function
Command	Select JUMP.
Sequence Start Condition	Use a memory operation condition data number to set the start condition. It is also possible to set no condition.
Jump/Repeat Condition	Set a memory operation condition data number. It is also possible to set no condition.
Jump Destination Sequence Number	Set the sequence number to jump to.

The program jumps to the specified sequence number for the specified conditions.

If the condition is False, the sequence number changes to the next number. If the condition is True, the sequence number changes to the specified number.

FOR

Set for sequence data for the FOR instruction. (Up to 50 nesting levels are possible.)

If you set FOR for the command, you can set the four types of sequence data given below.

Data name	Function
Command	Select FOR.
Sequence Start Condition	Use a memory operation condition data number to set the start condition. It is also possible to set no condition.
Jump/Repeat Condition	Set a memory operation condition data number. It is also possible to set no condition.
Repeat Loop Number	Set a number to pair the FOR and NEXT commands. The repeat loop number for a FOR command must be the same as the repeat loop number for the corresponding NEXT command.

Repeat control is performed for the FOR to NEXT loop for the specified conditions.

If the condition is True, the sequence number changes to the next one. If the condition is False, the sequence number changes to the sequence number next to the NEXT.

You must always set FOR and NEXT as a pair. Therefore, a repeat loop number is specified for both the FOR and NEXT command, and repeat control is performed between FOR and NEXT with the same repeat loop number.

An error will occur if a FOR command is executed and there is not a corresponding NEXT command with the same repeat loop number and vice versa.

The Repeat Loop Number can be set to between 0 and 49.

An error will occur if the same repeat loop number is used in more than one FOR or more than one NEXT command.

You can set up to 50 nesting levels for the FOR to NEXT loops.

NEXT

NEXT is used for sequence data for a NEXT command.

If you set NEXT for the command, you can set the three types of sequence data given below.

Data name	Function
Command	Select NEXT.
Sequence Start Condition	Use a memory operation condition data number to set the start condition. It is also possible to set no condition.
Repeat Loop Number	Set a number to pair the FOR and NEXT commands. The repeat loop number for a FOR command must be the same as the repeat loop number for the corresponding NEXT command.

The sequence number returns to the one for the corresponding FOR command for repeat control by the FOR to NEXT loop.

You must always set FOR and NEXT as a pair. Therefore, a repeat loop number is specified for both the FOR and NEXT command, and repeat control is performed between FOR and NEXT with the same repeat loop number.

An error will occur if a FOR command is executed and there is not a corresponding NEXT command with the same repeat loop number and vice versa.

The Repeat Loop Number can be set to between 0 and 49.

An error will occur if the same repeat loop number is used in more than one FOR or more than one NEXT command.

You can set up to 50 nesting levels for the FOR to NEXT loops.

PSET

PSET is used for sequence data that forcibly turns ON a PCU output.

If you set PSET for the command, you can set the three types of sequence data given below.

Data name	Function
Command	Select PSET.
Sequence Start Condition	Use a memory operation condition data number to set the start condition. It is also possible to set no condition.
Output Signal	Specify the destination of the forced output. 0000 hex: No output ##03 hex: Forward torque limit output ##04 hex: Reverse torque limit output ##: 01 to 04 (Indicate configuration axes, 01: Configuration axis 1, 02: Configuration axis 2, 03: Configuration axis 3, 04: Configuration axis 4) 8000 to 800F hex: Memory Operation Auxiliary Area (8,000 to 800F hex correspond to bits 00 to 15, respectively.)

You can forcibly turn ON signals only for the configuration axis of the applicable task.

Output status is retained during memory operation, but the PSET command is canceled when memory operation stops.

This command operates based on an OR with any output command from the PLC.



Precautions for Correct Use

- ◆ Before using a mode in which the torque limit data is modified directly from an allocated memory area to control the forward or reverse torque limit output via PSET, be sure to assign the torque limit data on the Direct Operation Command Memory Area. Otherwise, the torque will not be correctly generated.
For details, refer to *10-4 Torque Limits* on page 10-19.
- ◆ You can check whether the torque command is producing the required torque by monitoring the command torque and present torque values using the expanded monitor function.

PRSET

PRSET is used for sequence data that forcibly turns OFF a PCU output.

If you set PRSET as the command, you can set the three types of sequence data given below.

Data name	Function
Command	Select PRSET.
Sequence Start Condition	Use a memory operation condition data number to set the start condition. It is also possible to set no condition.
Output Signal	Specify the destination of the forced output. 0000 hex: No output ##03 hex: Forward torque limit output ##04 hex: Reverse torque limit output ##: 01 to 04 (Indicate configuration axes, 01: Configuration axis 1, 02: Configuration axis 2, 03: Configuration axis 3, 04: Configuration axis 4) 8000 to 800F hex: Memory Operation Auxiliary Area (8,000 to 800F hex correspond to bits 00 to 15, respectively.)

You can forcibly turn OFF signals only for the configuration axis of the applicable task.

Output status is retained during memory operation, but the PRSET command is canceled when memory operation stops.

This command operates based on an AND with any output command from the PLC.

**Precautions for Correct Use**

- ◆ Before using a mode in which the torque limit data is modified directly from an allocated memory area to control the forward or reverse torque limit output via PRSET, be sure to assign the torque limit data on the Direct Operation Command Memory Area. Otherwise, the torque will not be correctly generated.
For details, refer to *10-4 Torque Limits* on page 10-19.
- ◆ You can check whether the torque command is producing the required torque by monitoring the command torque and present torque values using the expanded monitor function.

END

END is used for sequence data that ends memory operation.

If you set END as the command, you can set the two types of sequence data given below.

Data name	Function
Command	Select END.
Sequence Start Condition	Use a memory operation condition data number to set the start condition. It is also possible to set no condition.

When you execute END, the executing sequence number changes to the sequence number that was effective when Sequence Number Enable Bit was turned ON.

Operation Commands

Operation commands have functions to control positioning, speed control, etc.

Positioning Operation (PTP)

Set for sequence data for positioning.

If you set Positioning Operation for the command, you can set the sequence data given below.

Data name	Function
Configuration Axis 1 Command Position	Set the position data. The command range is -2,147,483,648 to 2,147,483,647 (command units).
Configuration Axis 2 Command Position	Only the position data for the axes in the axis configuration that you specified in the memory operation parameters are enabled.
Configuration Axis 3 Command Position	
Configuration Axis 4 Command Position	
Command	Select Positioning Operation.
Sequence Start Condition	Use a memory operation condition data number to set the start condition. You can also set no condition.
Sequence Skip Condition	Use a memory operation condition data number to set the start condition. You can also set no condition.
End Pattern ^{*1}	Set the operation end pattern. 0: Individual 1: Automatic 2: Continuous 1 (Until the next sequence speed) 3: Continuous 2 (Acceleration/deceleration starts at the next sequence) 4: Continuous 3 (Pass: Overlap deceleration for the present sequence and acceleration for the next sequence)
Positioning Completed Input Monitor Valid	Select the positioning completed operation to use when an axis stops. 0: Do not wait for the completion of positioning 1: Wait for the completion of positioning
Dwell Timer	If the end pattern is set to Individual or Automatic, set the dwell time. 0: No dwell time 0.01 to 10.00 s: Dwell time (10-ms units)
M Code	Set the M code for after positioning has been completed. 0: No M code 1 to 499: M codes that wait to be reset 500 to 999: M codes that do not wait to be reset
Axis Specification	Set the axes to start. A start command is sent when each bit turns ON. Bit 00: Configuration axis 1 Bit 01: Configuration axis 2 Bit 02: Configuration axis 3 Bit 03: Configuration axis 4 Start only the axes in the axis configuration that you specified in the memory operation parameters.

Data name	Function
Position Specification	Select whether to use a relative position or absolute position for the command position. Turn OFF a bit to indicate an absolute position. Bit 00: Configuration axis 1 Bit 01: Configuration axis 2 Bit 02: Configuration axis 3 Bit 03: Configuration axis 4
Configuration Axis 1 Rotation Axis Direction	If you select a rotation axis in the applicable axis parameter, select the operating direction for positioning (PTP) for an absolute movement designation. 0: Shortest route 1: Forward 2: Reverse 3: Not specified Specify the rotation axis movement command only for the axes in the axis configuration that you specified in the memory operation parameters.
Configuration Axis 2 Rotation Axis Direction	
Configuration Axis 3 Rotation Axis Direction	
Configuration Axis 4 Rotation Axis Direction	
Configuration Axis 1 Command Speed	Set the target speed for the axis positioning operation (PTP). The command range is 1 to 2,147,483,647 (command units/s). Specify the command speed only for the axes in the axis configuration that you specified in the memory operation parameters.
Configuration Axis 2 Command Speed	
Configuration Axis 3 Command Speed	
Configuration Axis 4 Command Speed	
Configuration Axis 1 Acceleration Time	Set the acceleration time for positioning operation (PTP). The command range is 0 to 250,000 (ms). Specify the acceleration time only for the axes in the axis configuration that you specified in the memory operation parameters.
Configuration Axis 2 Acceleration Time	
Configuration Axis 3 Acceleration Time	
Configuration Axis 4 Acceleration Time	
Configuration Axis 1 Deceleration Time	Set the deceleration time for positioning operation (PTP). The command range is 0 to 250,000 (ms). Specify the deceleration time only for the axes in the axis configuration that you specified in the memory operation parameters.
Configuration Axis 2 Deceleration Time	
Configuration Axis 3 Deceleration Time	
Configuration Axis 4 Deceleration Time	

*1. If 2 (continuous 1), 3 (continuous 2), or 4 (continuous 3) is selected, the operation will be the same as if 1 (automatic) was selected.

Position control can be performed for up to four axes based on the specified sequence data as well as the maximum speed, starting speed, acceleration/deceleration curve selection, and acceleration/deceleration time selection that you set in the axis parameters.

You can also use an override for each axis. For information on overrides, refer to *10-3 Overrides* on page 10-13.

Linear Interpolation Operation

Set for sequence data for linear interpolation operation.

If you set Linear Interpolation Operation as the command, you can set the sequence data given below.

For information on linear interpolation, also refer to *8-4 Linear Interpolation* on page 8-50.

Data name	Function
Configuration Axis 1 Command Position	Set the position data. The command range is -2,147,483,648 to 2,147,483,647 (command units).
Configuration Axis 2 Command Position	Only the position data for the axes in the axis configuration that you specified in the memory operation parameters are enabled.
Configuration Axis 3 Command Position	
Configuration Axis 4 Command Position	
Command	
Sequence Start Condition	Use a memory operation condition data number to set the start condition. You can also set no condition.
Sequence Skip Condition	Use a memory operation condition data number to set the start condition. You can also set no condition.
End Pattern	Set the operation end pattern. 0: Individual 1: Automatic 2: Continuous 1 (Until the next sequence speed) 3: Continuous 2 (Acceleration/deceleration starts at the next sequence) 4: Continuous 3 (Pass: Overlap deceleration for the present sequence and acceleration for the next sequence)
Positioning Completed Input Monitor Valid	Select the positioning completed operation to use when an axis stops. 0: Do not wait for the completion of positioning 1: Wait for the completion of positioning
Dwell Timer	If the end pattern is set to Individual or Automatic, set the dwell time. 0: No dwell time 0.01 to 10.00 s: Dwell time (10-ms units)
M Code	Set the M code for after positioning has been completed. 0: No M code 1 to 499: M codes that wait to be reset 500 to 999: M codes that do not wait to be reset
Axis Specification	Set the axes to start. A start command is sent when each bit turns ON. Bit 00: Configuration axis 1 Bit 01: Configuration axis 2 Bit 02: Configuration axis 3 Bit 03: Configuration axis 4 Start only the axes in the axis configuration that you specified in the memory operation parameters.
Position Specification	Select whether to use a relative position or absolute position for the command position. Turn OFF a bit to indicate an absolute position. Bit 00: Configuration axis 1 Bit 01: Configuration axis 2 Bit 02: Configuration axis 3 Bit 03: Configuration axis 4

Data name	Function
Interpolation Speed	Set the interpolation speed. The command range is 1 to 2,147,483,647 (command units/s).
Interpolation Acceleration Time	Set the interpolation acceleration time. The command range is 0 to 250,000 (ms).
Interpolation Deceleration Time	Set the interpolation deceleration time. The command range is 0 to 250,000 (ms).
Interpolation Starting Speed	Set the interpolation starting speed. The command range is 0 to 2,147,483,647 (command units/s).
Interpolation Acceleration/Deceleration Curve Selection	Select the curve for interpolation acceleration/deceleration. 0: Trapezoid, 1: S-curve (tertiary curve)
Interpolation Acceleration/Deceleration Time Selection	Select the specification method for the interpolation acceleration/deceleration time. 0: Time from starting speed to maximum speed of each axis (constant acceleration/deceleration rate) 1: Time from present speed to target speed of each axis (constant acceleration/ deceleration time)
Interpolation Speed Specification Method	Select the Interpolation Speed Specification Method for linear interpolation. 0: Specify the interpolation path speed. 1: Specify the maximum speed.

Linear interpolation can be performed for up to four axes based on the specified sequence data. You can also use the override for the priority axis of the configuration axes. For information on overrides, refer to *10-3 Overrides* on page 10-13.

Circular Interpolation

Sequence data can be set for circular interpolation.

To perform circular interpolation, the interpolated axes must be set as linear axes (finite lengths) in the Axis Feeding Mode parameters. For information on the Axis Feeding Mode, refer to *Command Position Unit Setting* on page 6-40.

If you set Circular Interpolation as the command, you can set the sequence data given below. For information on circular interpolation, also refer to *8-5 Circular Interpolation* on page 8-53.

Data name	Function
Configuration Axis 1 Command Position	Set the position data. The command range is -2,147,483,648 to 2,147,483,647 (command units).
Configuration Axis 2 Command Position	Only the position data for the axes in the axis configuration that you specified in the memory operation parameters are enabled.
Configuration Axis 3 Command Position	
Configuration Axis 4 Command Position	
Command	Select clockwise circular interpolation or counterclockwise circular interpolation.
Sequence Start Condition	Use a memory operation condition data number to set the start condition. You can also set no condition.
Sequence Skip Condition	Use a memory operation condition data number to set the start condition. You can also set no condition.

Data name	Function
End Pattern	Set the operation end pattern. 0: Individual 1: Automatic 2: Continuous 1 (Until the next sequence speed) 3: Continuous 2 (Acceleration/deceleration starts at the next sequence) 4: Continuous 3 (Pass: Overlap deceleration for the present sequence and acceleration for the next sequence)
Positioning Completed Input Monitor Valid	Select the positioning completed operation to use when an axis stops. 0: Do not wait for the completion of positioning 1: Wait for the completion of positioning
Dwell Timer	If the end pattern is set to Individual or Automatic, set the dwell time. 0: No dwell time 0.01 to 10.00 s: Dwell time (10-ms units)
M Code	Set the M code for after positioning has been completed. 0: No M code 1 to 499: M codes that wait to be reset 500 to 999: M codes that do not wait to be reset
Axis Specification	Set the axes to start. A start command is sent when each bit turns ON. Bit 00: Configuration axis 1 Bit 01: Configuration axis 2 Bit 02: Configuration axis 3 Bit 03: Configuration axis 4 Start only the axes in the axis configuration that you specified in the memory operation parameters.
Position Specification	Select whether to use a relative position or absolute position for the command position. Turn OFF a bit to indicate an absolute position. Bit 00: Configuration axis 1 Bit 01: Configuration axis 2 Bit 02: Configuration axis 3 Bit 03: Configuration axis 4
Interpolation Speed	Set the interpolation speed. The command range is 1 to 2,147,483,647 (command units/s).
Interpolation Acceleration Time	Set the interpolation acceleration time. The command range is 0 to 250,000 (ms).
Interpolation Deceleration Time	Set the interpolation deceleration time. The command range is 0 to 250,000 (ms).
Interpolation Starting Speed	Set the interpolation starting speed. The command range is 0 to 2,147,483,647 (command units/s).
Interpolation Acceleration/Deceleration Curve Selection	Select the curve for interpolation acceleration/deceleration. 0: Trapezoid, 1: S-curve (tertiary curve)
Interpolation Acceleration/Deceleration Time Selection	Select the specification method for the interpolation acceleration/deceleration time. 0: Time from starting speed to maximum speed of each axis (constant acceleration/deceleration rate) 1: Time from present speed to target speed of each axis (constant acceleration/ deceleration time)

Data name	Function
Configuration Axis 1 Circular Center/ Passing Point Position	Set the center position of the arc if the center point was selected for the Circular Interpolation Method. Set the passing point position on the arc if the passing point selected for the Circular Interpolation Method. The command range is -2,147,483,648 to 2,147,483,647 (command units).
Configuration Axis 2 Circular Center/ Passing Point Position	
Configuration Axis 3 Circular Center/ Passing Point Position	
Configuration Axis 4 Circular Center/ Passing Point Position	
Circular Radius	If you select radius designation for the Circular Interpolation Method, set the circular radius to between -2,147,483,648 and 2,147,483,647 (command units).
Circular Interpolation Method	Select the specification method for circular interpolation. 0: Specify the circular center 1: Specify the radius 2: Specify a passing point

Circular interpolation can be performed for two axes based on the specified sequence data. You can also use the override for the priority axis of the configuration axes. For information on overrides, refer to *10-3 Overrides* on page 10-13.

Speed Control

Sequence data can be set for speed control. Specify speed control separately for each axis. If you set Speed Control for the command, you can set the sequence data given below.

Data name	Function
Command	Select Speed Control.
Sequence Start Condition	Use a memory operation condition data number to set the start condition. You can also set no condition.
Sequence Skip Condition	Use a memory operation condition data number to set the start condition. You can also set no condition.
End Pattern ^{*1}	Set the operation end pattern. 0: Individual 1: Automatic 2: Continuous 1 (Until the next sequence speed) 3: Continuous 2 (Acceleration/deceleration starts at the next sequence) 4: Continuous 3 (Pass: Overlap deceleration for the present sequence and acceleration for the next sequence)
Positioning Completed Input Monitor Valid	Select the positioning completed operation to use when an axis stops. 0: Do not wait for the completion of positioning 1: Wait for the completion of positioning
Dwell Timer	If the end pattern is set to Individual or Automatic, set the dwell time. 0: No dwell time 0.01 to 10.00 s: Dwell time (10-ms units)
M Code	Set the M code for after positioning has been completed. 0: No M code 1 to 499: M codes that wait to be reset 500 to 999: M codes that do not wait to be reset
Axis Specification	Set the axes to start. A start command is sent when each bit turns ON. Bit 00: Configuration axis 1 Bit 01: Configuration axis 2 Bit 02: Configuration axis 3 Bit 03: Configuration axis 4 Start only the axes in the axis configuration that you specified in the memory operation parameters.
Command Speed	Set the target speed to use in speed control. The command range is -2,147,483,648 to 2,147,483,647 (command units/s).
Acceleration Time	Set the acceleration time to use in speed control to between 0 and 250,000 (ms).
Deceleration Time	Set the deceleration time to use in speed control to between 0 and 250,000 (ms).

*1. If 2 (continuous 1), 3 (continuous 2), or 4 (continuous 3) is selected, the operation will be the same as if 1 (automatic) was selected.

Speed control can be performed for one axis based on the specified sequence data as well as the maximum speed, starting speed, acceleration/deceleration curve selection, and acceleration/deceleration time selection that you set in the axis parameters.

You can also use overrides for each axis. For information on overrides, refer to *10-3 Overrides* on page 10-13.

Interrupt Feeding for Positioning Operation

Set for sequence data for interrupt feeding for positioning.

Specify interrupt feeding separately for each axis.

If you set Interrupt Feeding (Positioning Operation) for the command, you can set the sequence data given below.

Data name	Function
Configuration Axis 1 Command Position	Set the position data. The command range is -2,147,483,648 to 2,147,483,647 (command units).
Configuration Axis 2 Command Position	Only the position data for the axes in the axis configuration that you specified in the memory operation parameters are enabled.
Configuration Axis 3 Command Position	
Configuration Axis 4 Command Position	
Command	Select Interrupt Feeding (Positioning Operation).
Sequence Start Condition	Use a memory operation condition data number to set the start condition. You can also set no condition.
Sequence Skip Condition	Use a memory operation condition data number to set the start condition. You can also set no condition.
End Pattern ^{*1}	Set the operation end pattern. 0: Individual 1: Automatic 2: Continuous 1 (Until the next sequence speed) 3: Continuous 2 (Acceleration/deceleration starts at the next sequence) 4: Continuous 3 (Pass: Overlap deceleration for the present sequence and acceleration for the next sequence)
Positioning Completed Input Monitor Valid	Select the positioning completed operation to use when an axis stops. 0: Do not wait for the completion of positioning 1: Wait for the completion of positioning
Dwell Timer	If the end pattern is set to Individual or Automatic, set the dwell time. 0: No dwell time 0.01 to 10.00 s: Dwell time (10-ms units)
M Code	Set the M code for after positioning has been completed. 0: No M code 1 to 499: M codes that wait to be reset 500 to 999: M codes that do not wait to be reset
Axis Specification	Set the axes to start. A start command is sent when each bit turns ON. Bit 00: Configuration axis 1 Bit 01: Configuration axis 2 Bit 02: Configuration axis 3 Bit 03: Configuration axis 4 Start only the axes in the axis configuration that you specified in the memory operation parameters.
Position Specification	Select whether to use a relative position or absolute position for the command position. Turn OFF a bit to indicate an absolute position. Bit 00: Configuration axis 1 Bit 01: Configuration axis 2 Bit 02: Configuration axis 3 Bit 03: Configuration axis 4

Data name	Function
Rotation Axis Direction	<p>If you select a rotation axis in the axis parameters, select the operating direction for interrupt feeding for an absolute movement.</p> <p>0: Shortest route 1: Forward 2: Reverse 3: Not specified</p> <p>Specify the rotation axis movement command only for the axes in the axis configuration that you specified in the memory operation parameters.</p>
Command Speed	<p>Set the target speed for axis in interrupt feeding.</p> <p>The command range is 1 to 2,147,483,647 (command units/s).</p>
Acceleration Time	<p>Set the acceleration time to use for interrupt feeding.</p> <p>The command range is 0 to 250,000 (ms).</p>
Deceleration Time	<p>Set the deceleration time to use for interrupt feeding.</p> <p>The command range is 0 to 250,000 (ms).</p>
Interrupt Feeding Reference Position Selection	<p>Select whether to use the command position or feedback position for the target value of interrupt feeding for the interrupt input.</p> <p>0: Command position 1: Feedback position</p>
Interrupt Feeding Amount	<p>Set the amount of movement to use in interrupt feeding. The command range is -2,147,483,648 to 2,147,483,647 (command units).</p>
Error Enable for Undetected Interrupt Input	<p>Select whether to output an error when an interrupt input is not received before positioning is completed during interrupt feeding for position control.</p> <p>0: Without error detection 1: With error detection</p>

*1. If 2 (continuous 1), 3 (continuous 2), or 4 (continuous 3) is selected, the operation will be the same as if 1 (automatic) was selected.

Interrupt feeding for positioning operation can be performed for one axis based on the specified sequence data as well as the maximum speed, starting speed, acceleration/deceleration curve selection, and acceleration/deceleration time selection that you set in the axis parameters.

You can also use overrides for each axis. For information on overrides, refer to *10-3 Overrides* on page 10-13.

Interrupt Feeding for Speed Control

Sequence data can be set for interrupt feeding for speed control.

Specify interrupt feeding separately for each axis.

If you set Interrupt Feeding (Speed Control) for the command, you can set the sequence data given below.

Data name	Function
Command	Select Interrupt Feeding (Speed Control).
Sequence Start Condition	Use a memory operation condition data number to set the start condition. You can also set no condition.
Sequence Skip Condition	Use a memory operation condition data number to set the start condition. You can also set no condition.

Data name	Function
End Pattern ^{*1}	Set the operation end pattern. 0: Individual 1: Automatic 2: Continuous 1 (Until the next sequence speed) 3: Continuous 2 (Acceleration/deceleration starts at the next sequence) 4: Continuous 3 (Pass: Overlap deceleration for the present sequence and acceleration for the next sequence)
Positioning Completed Input Monitor Valid	Select the positioning completed operation to use when an axis stops. 0: Do not wait for the completion of positioning 1: Wait for the completion of positioning
Dwell Timer	If the end pattern is set to Individual or Automatic, set the dwell time. 0: No dwell time 0.01 to 10.00 s: Dwell time (10-ms units)
M Code	Set the M code for after positioning has been completed. 0: No M code 1 to 499: M codes that wait to be reset 500 to 999: M codes that do not wait to be reset
Axis Specification	Set the axes to start. A start command is sent when each bit turns ON. Bit 00: Configuration axis 1 Bit 01: Configuration axis 2 Bit 02: Configuration axis 3 Bit 03: Configuration axis 4 Start only the axes in the axis configuration that you specified in the memory operation parameters.
Command Speed	Set the target speed for each axis in interrupt feeding (speed control). The command range is -2147483648 to 2,147,483,647 (command units/s).
Acceleration Time	Set the acceleration time to use for interrupt feeding (speed control). The command range is 0 to 250,000 (ms).
Deceleration Time	Set the deceleration time to use for interrupt feeding (speed control). The command range is 0 to 250,000 (ms).
Interrupt Feeding Reference Position Selection	Select whether to use the command position or feedback position for the target value of interrupt feeding for the interrupt input. 0: Command position 1: Feedback position
Interrupt Feeding Amount	Set the amount of movement to use in interrupt feeding. The command range is -2,147,483,648 to 2,147,483,647 (command units).

*1. If 2 (continuous 1), 3 (continuous 2), or 4 (continuous 3) is selected, the operation will be the same as if 1 (automatic) was selected.

Interrupt feeding (speed control) can be performed for one axis based on the specified sequence data as well as the maximum speed, starting speed, acceleration/deceleration curve selection, and acceleration/deceleration time selection that you set in the axis parameters.

You can also use overrides for each axis. For information on overrides, refer to *10-3 Overrides* on page 10-13.

Setting Conditions

This section describes the following settings: Start Condition, Sequence Skip Condition, Dwell Timer (i.e., the end condition), Positioning Completed Input Monitor Valid, and M Code.

Start Condition

Use a memory operation condition data number to specify the sequence start condition.

If no condition is set, the sequence will start unconditionally.

If the condition is False, the PCU does not start the sequence, but continues to wait until the condition becomes True.

Once the condition becomes True, the PCU executes memory operation based on the sequence number.

Sequence Skip Condition

A sequence skip condition can be set for operation commands.

If no condition is set, the operation will be performed without stopping or skipping.

If the sequence skip condition is True at the start of sequence, the sequence is skipped and the PCU executes the next sequence.

If the sequence skip condition changes from False to True while the sequence is being executed, execution of the sequence stops.

If the end pattern is set to Individual, the axis will be stopped or standby will be canceled, the sequence number will be advanced, and operation will stop.

If the end pattern is set to Automatic or Continuous, the axis will be stopped if it is operating and the next sequence will be started.

Dwell Timer

The dwell timer is used to allow time to suppress residual machine vibration when moving to the next sequence. The dwell time starts after positioning has been normally completed for the sequence. Completion of the positioning of the sequence is determined according to the setting of Positioning Completed Input Monitor Valid parameter.

The dwell timer can be specified for operation commands when the end pattern is Individual or Automatic.

Dwelling is not applied for deceleration stop commands.

Dwelling is canceled for errors that occur while dwelling, for deceleration stop commands, and when stopping for sequence skip conditions.

Positioning Completed Input Monitor Valid

You can specify positioning completed input monitoring assessment when you specify an operation command and the end pattern is Individual or Automatic.

If you configure the PCU not to wait for the completion of positioning, positioning will be considered to be completed when reference output has been completed.

If you set 1 (waiting for the completion of positioning),

- ♦ positioning completed signals are output for each axis for PTP positioning operations and interrupt feeding.
- ♦ For interpolated operations, a positioning completed signal is output for all configuration axes in the task, and not for individual axes.

Operation will not wait for the completion of positioning for deceleration stop commands.

The completion of positioning does not apply for errors that occur while dwelling, for deceleration stop commands, and when stopping for sequence skip conditions.

If you set the Positioning Monitoring Time axis parameter to 0, arrival will not be monitored for the Servo Drive feedback position regardless of the setting of this parameter. Refer to 10-6 *Positioning Completion* for details.

M Code

M codes are the codes that you use to align timing with external devices to the PLC in each positioning operation process.

You can specify an M code for each memory operation sequence block when you specify an operation command.

There are two types of M codes: M codes 1 to 499 require resetting, and M codes 500 to 999 do not require resetting.

M codes that require resetting can be specified when the end pattern is set to Individual or Automatic.

8-3 Memory Operation

M Codes 1 to 499

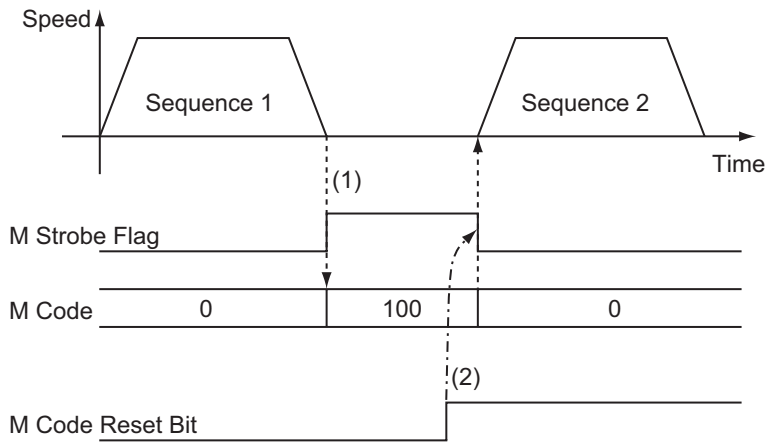

- (1) After positioning has been completed, the M code is output and the PCU waits to reset the M code.
- (2) When the M Code Reset Bit is turned ON, the M code is cleared and the next sequence is executed.

M Codes 500 to 999

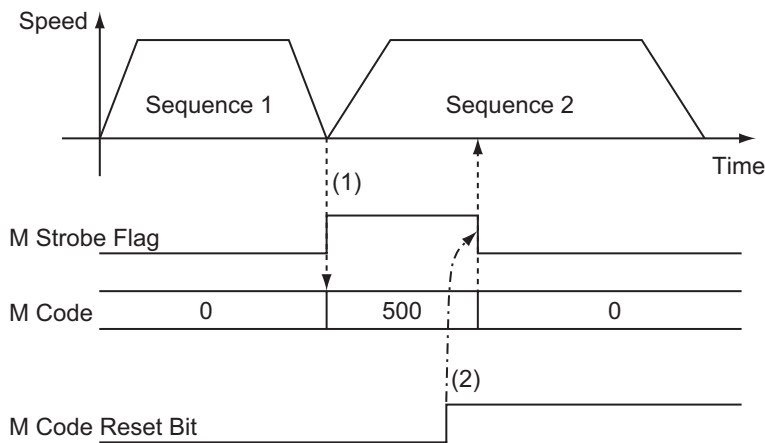

- (1) After positioning has been completed, the M code is output and the next sequence is executed.
- (2) When the M Code Reset Bit is turned ON, the M code is cleared.
The M code is also cleared when a sequence with an END command is executed.

End Pattern

An operation end pattern is set.

There are five end patterns: individual, automatic, continuous 1, continuous 2, and continuous 3.

You can specify an end pattern when you specify an operation command.

The operations performed for each end pattern are described below.



Precautions for Correct Use

- ◆ Specifying continuous 1 to 3 is enabled only when the sequence is an interpolation operation. If continuous 1 to continuous 3 is specified for operations other than interpolation, the operation will be the same as for an automatic end pattern.
- ◆ To implement continuous operation, you must set the command to Linear Interpolation or Circular Interpolation, and you must not set a sequence start condition for the next sequence.
- ◆ An attempt to execute continuous operation will cause an error and fail if any of the limit inputs is ON for the configuration axes specified for the task.

Individual

When the Memory Operation Start Bit in the Memory Operation Command Memory Area turns ON, the specified sequence is executed, the Executing Sequence Number is updated, and then the operation ends.

The sequence number is updated to the next number, so the next sequence is executed when the Memory Operation Start Bit is turned ON again.

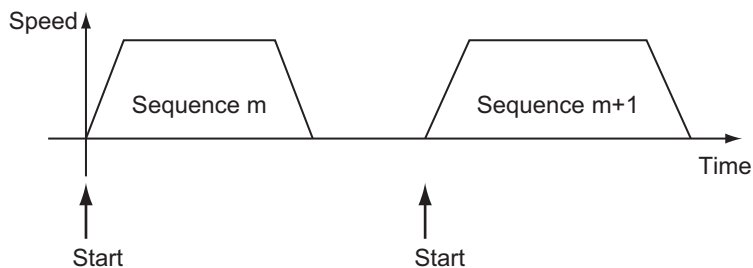

Automatic

When the Memory Operation Start Bit in the Memory Operation Command Memory Area turns ON, the specified sequence is executed. When the condition for the next sequence number is satisfied, also the next sequence is executed automatically.

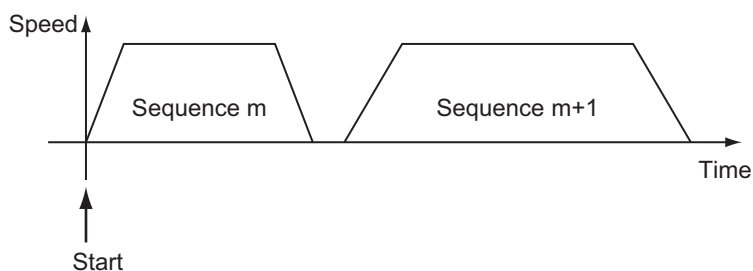

Continuous 1 (Until the Next Sequence Speed)

When the Memory Operation Start Bit in the Memory Operation Command Memory Area turns ON, the specified sequence is executed and then the next sequence is executed without stopping.

For a continuous 1 end pattern, the speed for the next sequence is reached before reaching the position of the specified sequence.

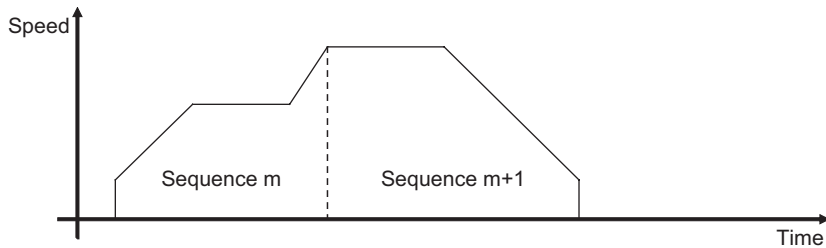

Continuous 2 (Acceleration/Deceleration Starts at the Next Sequence)

When the Memory Operation Start Bit in the Memory Operation Command Memory Area turns ON, the specified sequence is executed and then the next sequence is executed without stopping.

For a continuous 2 end pattern, the acceleration or deceleration for the next sequence starts after reaching the position for the specified sequence.

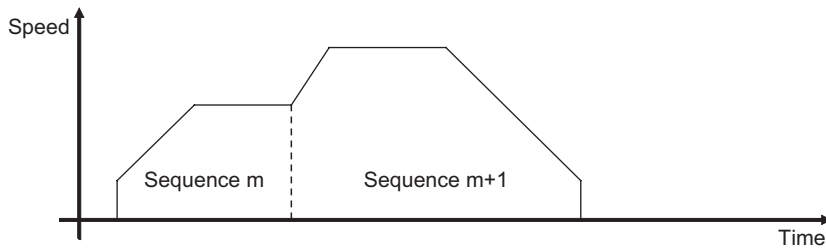

Continuous 3 (Overlapping Deceleration in the Applicable Sequence and Acceleration in the Next Sequence)

When the Memory Operation Start Bit in the Memory Operation Command Memory Area turns ON, the specified sequence is executed and then the next sequence is executed without stopping.

For a continuous 3 end pattern, the deceleration for the specified sequence and the acceleration for the next sequence are overlapped to achieve smooth interpolation operation. The sequence number is advanced at the end of the overlapped section.

The acceleration/deceleration curve of the first sequence is used in the overlapped section. For example, if a trapezoid acceleration/deceleration curve is set for the first sequence and an S-curve is set for the second sequence, trapezoid deceleration/acceleration will be used in the overlapped section for a continuous 3 end pattern. This is to prevent the maximum speed from being exceeded if a trapezoid curve and S-curve are overlapped. It will prevent the speed in the overlapped section from exceeding the target speed of either sequence. The same thing applies when both sequences have S-curve acceleration/deceleration.

If the same axes are not moved in the first and second sequences, the acceleration/deceleration curves set for each sequence will be used. For example, when moving between X-axis linear interpolation and Y-axis linear interpolation with a continuous 3 end pattern, and a trapezoid curve is set for the X-axis linear interpolation and an S-curve is set for the Y-axis linear interpolation, the acceleration/deceleration curve that is set for each axis will be used.

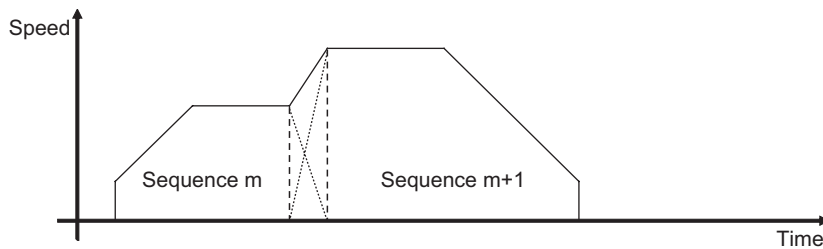



Precautions for Correct Use

Precautions on Continuous Operation

- Continuous 1 to 3 can be specified for linear interpolation or circular interpolation operation. To implement continuous operation, the next sequence must also be for linear interpolation or circular interpolation and must not have a start condition.
- For the sequences you want to operate continuously, set the amount of movement that requires a positioning time of two control cycles or longer. If the required positioning time is less than one control cycle, the operation conforms to an automatic end pattern.
- If the sequence next to the one for which you specified the continuous start includes a NOP command or comment, the sequence skips up to four sequences and operation continues with the next sequence. If there are five or more sets of sequence data that include a NOP command or comment, the operation for an automatic end pattern is performed.
- For continuous operation, the speeds of the two sequences will be connected to achieve a continuous interpolation path speed. If continuous operation is performed with a sequence that contains a travel amount of 0, the speed changes for the axes will not be continuous.

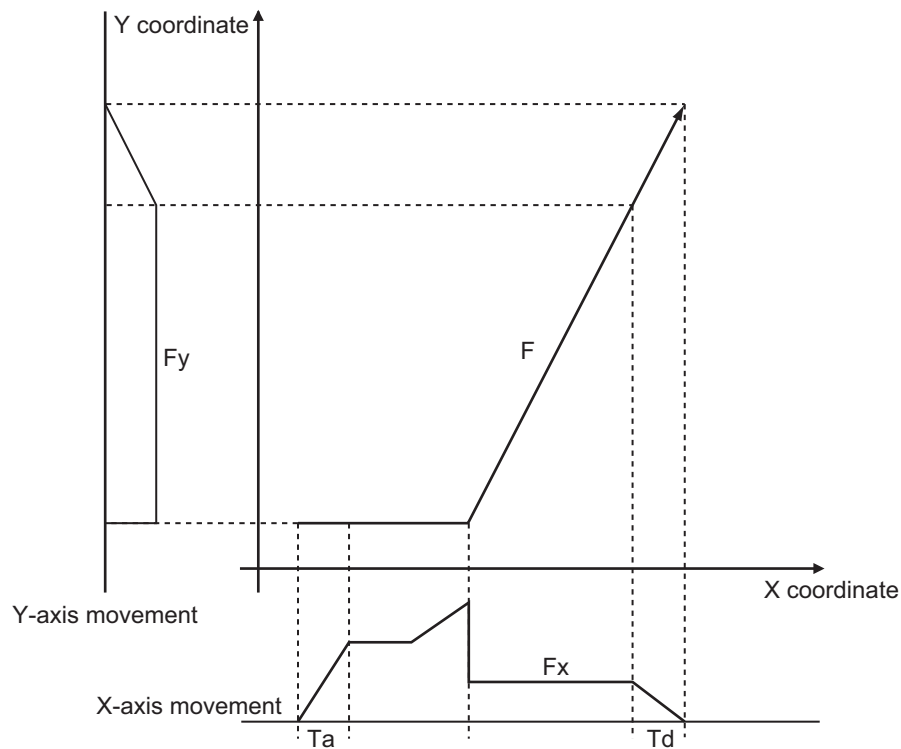

Axis Status during Continuous Operation

The Pass Flag that indicates an axis status remains ON while the axis movement with a continuous 1 or continuous 3 end pattern is accelerating or decelerating toward the target speed of the next sequence.

If you select continuous 2 as the end pattern, the Pass Flag does not turn ON because the next sequence starts at the present speed.

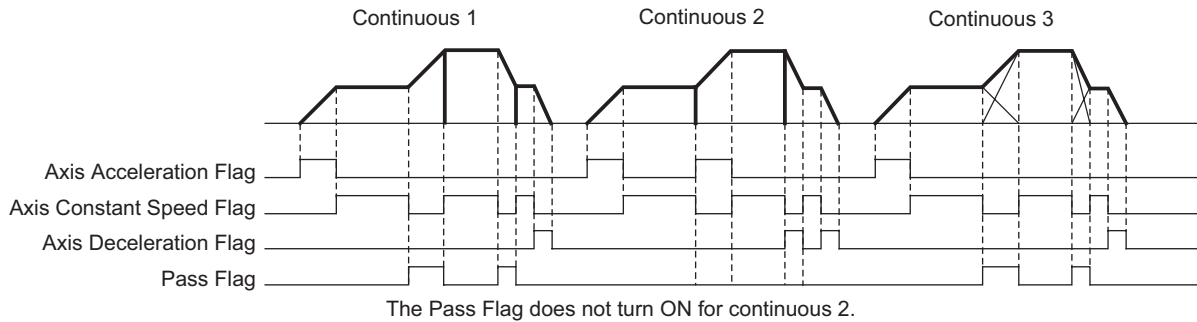

Stopping Memory Operation

The following are the five possible causes of an axis stop during memory operation.

- ◆ The Memory Operation Stop Bit turned ON.
- ◆ The Deceleration Stop Bit for the axis turned ON.
- ◆ The Servo Unlock Bit for the axis turned ON.
- ◆ The Deviation Counter Reset Bit for the axis turned ON.
- ◆ The axis stopped due to an error.

This section describes the operation that follows when the axis is stopped for above causes.

Memory Operation Stop Bit

The current memory operation stops and all configuration axes in memory operation decelerate to a stop using the deceleration time that you set in the current memory operation data. For an interpolation operation, the axes decelerate to a stop along the interpolation path.

Deceleration Stop Bit for Each Axis

If a deceleration stop is executed for any of the configuration axes during memory operation, the operation will depend on the command that is being executed, as described below.

It is assumed that the deceleration stop input was received even for axes that are not operating.

PTP Commands

The axis for which you execute a deceleration stop decelerates to a stop according to the deceleration time that you set in the memory operation data.

All other operating axes continue positioning according to the PTP commands.

With PTP commands, the operation of each axis is individual and thus operational changes to one axis do not affect the other axes.

Linear Interpolation/Circular Interpolation Commands

The axes stop as follows, according to the setting of the Interpolated Axis Stop Method memory operation parameter.

Interpolation Axis Stop Method	Stopping operation
Interpolation path deceleration stop	All interpolated axes decelerate to a stop along the interpolated path. The deceleration time that you set in the current memory operation data is used. If you use multiple continuous patterns, the axes stop according to the time in each pattern.
Immediate stop	The configuration axes for which a deceleration stop was executed will decelerate to a stop according to the Single Axis Deceleration Time at Interpolation axis parameter. An immediate stop will be used for the other interpolation axes.
RUN OFF	The configuration axes for which a deceleration stop was executed will decelerate to a stop according to the Single Axis Deceleration Time at Interpolation axis parameter. A free-run stop will be used for the other interpolation axes.
Single axis deceleration stop	All interpolated axes including the configuration axes for which a deceleration stop was executed will decelerate to a stop according to the Single Axis Deceleration Time at Interpolation axis parameter.

The axes that are stopped for interpolation commands are the interpolated axes, not the memory configuration axes.

Therefore, if interpolation is being performed for configuration axes 1 and 2 in a task with configuration axes 1 to 4 in the axis configuration, only configuration axes 1 and 2 will be stopped. Operation will not be stopped and the RUN output will not be turned OFF for configuration axes 3 and 4.

Servo Unlock Bit and Deviation Counter Reset Bit for Each Axis

If the servo is unlocked or the deviation counter is reset for any of the configuration axes during memory operation, the operation will depend on the command that is being executed, as described below.

PTP Commands

Servo unlock and deviation counter reset operations are executed for the axis for which the Servo Unlock Bit or Deviation Counter Reset Bit was turned ON. All other operating axes continue positioning according to the PTP commands.

Linear Interpolation/Circular Interpolation Commands

Servo unlock and deviation counter reset operations are executed for the axis for which the Servo Unlock Bit or Deviation Counter Reset Bit was turned ON. Other interpolation axes stop as follows, according to the setting of the Interpolation Axis Stop Method memory operation parameter.

Interpolation Axis Stop Method	Stopping operation
Interpolation path deceleration stop	This setting is not supported. If it is used, it functions as the single axis deceleration stop setting.
Immediate stop	An immediate stop will be used for the other interpolation axes.
RUN OFF	A free-run stop will be used for the other interpolation axes.
Single axis deceleration stop	All other interpolated axes will be decelerated to a stop according to the Single Axis Deceleration Time at Interpolation axis parameter.

The axes that are stopped for interpolation commands are the interpolated axes, not the memory configuration axes.

Therefore, if interpolation is being performed for configuration axes 1 and 2 in a task with configuration axes 1 to 4 in the axis configuration, only configuration axes 1 and 2 will be stopped. Operation will not be stopped and the RUN output will not be turned OFF for configuration axes 3 and 4.

Errors

If an error occurs, the axes decelerate to a stop, as a rule.

However, if a sensor error occurs for an emergency stop input, limit input, or Servo Drive alarm input, the operation of the configuration axis where the error occurs will be according to the I/O function set for that axis in the I/O Function Selection parameter.

The following operation will be used if a deceleration stop is executed for an error.

- ♦ If a deceleration stop is executed due to a memory operation error, the operation will be the same as for a memory operation stop.
- ♦ If an axis error occurs, a configuration axis error (error code: 6C02) will occur for the task where the axis is set as a configuration axis and the operation will be the same as for a memory operation stop.
- ♦ If the specified stopping method is not a deceleration stop for a sensor error for an emergency stop input, limit input, or Servo Drive alarm input, the operation will be the same as for the Servo Unlock Bit or Deviation Counter Reset Bit for each axis.

Stopping on Interpolation Path

If you execute a deceleration stop during continuous interpolation, the axes decelerate without deviating from the path. The deceleration time that is set in the sequence is used. If you execute a deceleration stop over multiple sequences, the deceleration curve changes based on the deceleration time in each sequence. The sequence number changes in the same manner as for normal operation.

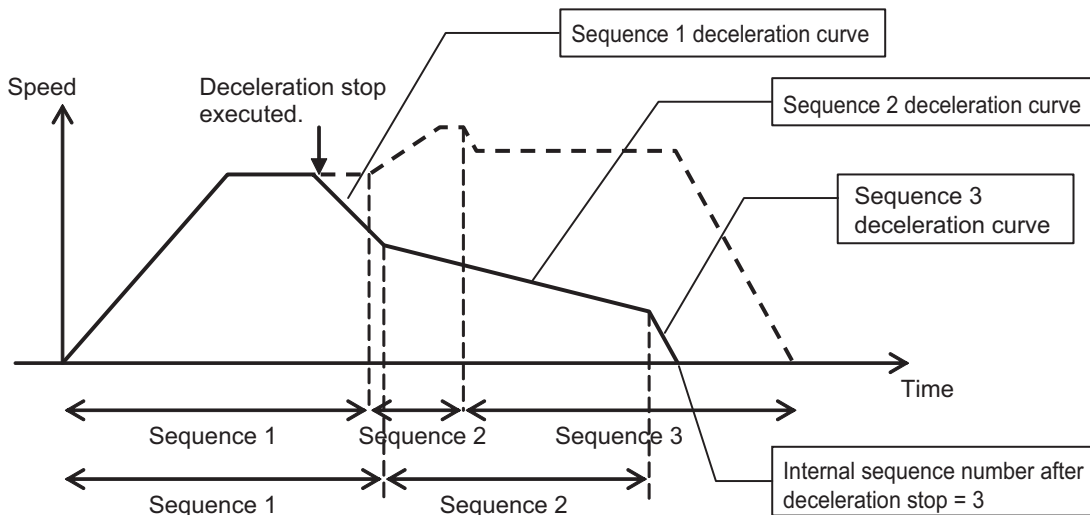

8-4 Linear Interpolation

Linear interpolation performs positioning in a straight line with configuration axes 1 to 4 between the point where the axes are currently stopped and a specified point.

For setting details, refer to *Linear Interpolation Operation* on page 8-31.

The following chart shows linear interpolation of two axes (axes 1 and 2) from point A to point B.

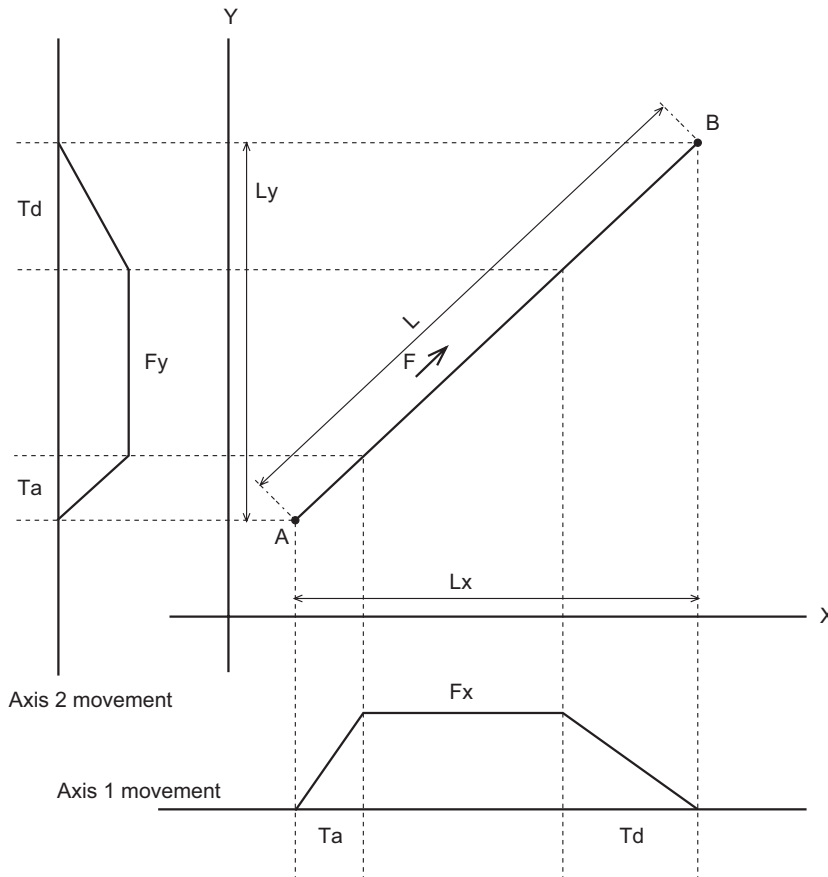

F: Specified interpolation feeding speed

Fx: Interpolation feeding speed based on expansion of F to axis 1

Fy: Interpolation feeding speed based on expansion of F to axis 2

Ta: Interpolation acceleration time

Td: Interpolation deceleration time

If the amount of movement along the path is given by L and amounts of movement of axes 1 and 2 by Lx and Ly, Fx and Fy can be expressed by the formula below:

$$F_x = \frac{L_x}{L} \times F$$

$$F_y = \frac{L_y}{L} \times F$$



Reference

- The Operation Flags, Acceleration Flags, Constant Speed Flags, Deceleration Flags, and other status for interpolated axes is not the status of the individual axes, but the status of the interpolation path. Therefore, all interpolated axes have the same status during interpolation.

Linear Interpolation Speed

The speed of each axis during linear interpolation is determined by the Interpolation Speed Specification Method that is set in the sequence data.

Set the Interpolation Speed Specification Method to Interpolation Path Speed or Maximum Speed.

Interpolation Path Speed

The interpolated path speed conforms to the Interpolation Speed that is set in the sequence data. The speeds of individual axes can be calculated from the following formulas. (The same formulas also apply to linear interpolation of 2 or 3 axes.)

Example: Simultaneous Linear Interpolation of 4 Axes

Speed of configuration axis 1 = Interpolation speed × Travel distance of configuration axis 1/Total travel distance

Speed of configuration axis 2 = Interpolation speed × Travel distance of configuration axis 2/Total travel distance

Speed of configuration axis 3 = Interpolation speed × Travel distance of configuration axis 3/Total travel distance

Speed of configuration axis 4 = Interpolation speed × Travel distance of configuration axis 4/Total travel distance

$$\text{Total movement} = \sqrt{\text{Configuration axis 1 travel distance}^2 + \text{Configuration axis 2 travel distance}^2 + \text{Configuration axis 3 travel distance}^2 + \text{Configuration axis 4 travel distance}^2}$$

If you break down the interpolation speed into the speed of each axis according to the above formulas and that speed exceeds the setting of the Maximum Speed parameter for the axis, the interpolation speed is automatically reduced to operate the axes at the maximum speed.

Maximum Speed

The interpolation speed is automatically calculated so that one of the axes operates at the maximum speed that is set in the axis parameters.

If this setting is used, the interpolation speed that is set in the sequence data is disabled.

Interpolation Acceleration Time and Interpolation Deceleration Time

Set the acceleration time and deceleration time for interpolation control.
 For the interpolation acceleration time and interpolation deceleration time, the setting of the Interpolation Acceleration/Deceleration Time Selection parameter determines the operation.

Interpolation Acceleration/Deceleration Time Selection

The Interpolation Acceleration/Deceleration Time Selection parameter can be set to Constant Acceleration Rate or Constant Time.

Use Constant Acceleration/Deceleration Rate to shorten the positioning time for linear interpolation of only 1 axis.

Constant Acceleration Rate

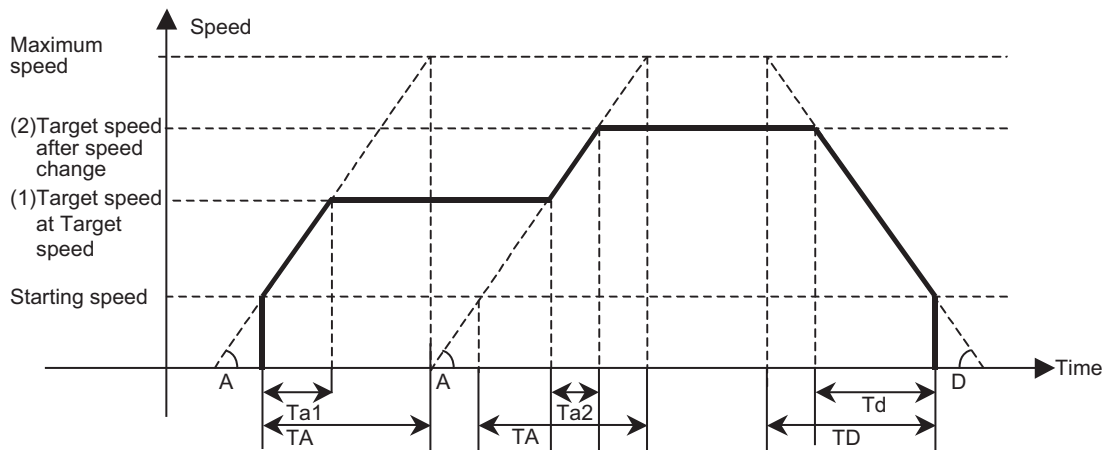

At Startup	For Speed Changes	During Deceleration
TA: Acceleration time	TA: Acceleration time	TD: Deceleration time
Ta1: Actual acceleration time	Ta2: Actual acceleration time	Td: Actual deceleration time
A: Acceleration rate	A: Acceleration rate	D: Rate of deceleration

Constant Acceleration/Deceleration Time

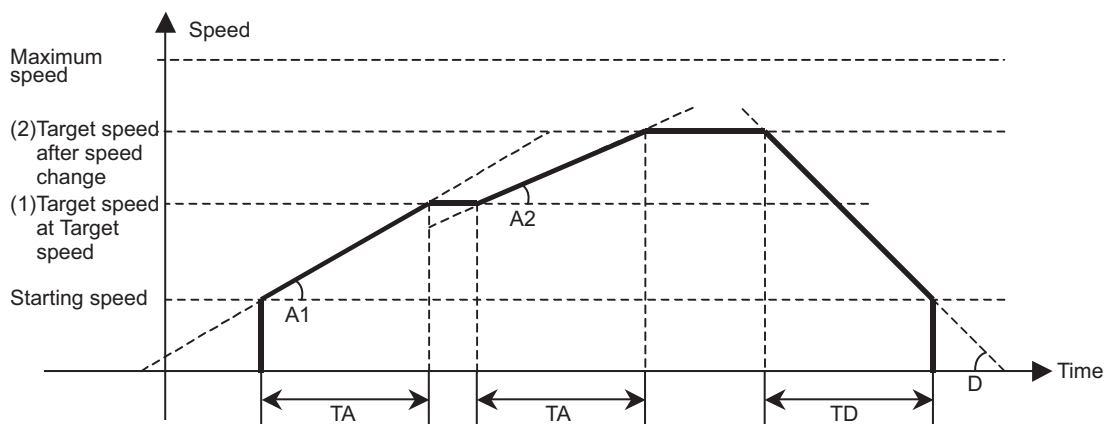

At Startup	For Speed Changes	During Deceleration
TA: Acceleration time	TA: Acceleration time	TD: Deceleration time
A1: Acceleration rate	A2: Acceleration rate	D: Rate of deceleration

8-5 Circular Interpolation

In circular interpolation, 2 axes are positioned in a circular pattern between the start point and end point.

For setting details, refer to *Circular Interpolation* on page 8-32.

To perform circular interpolation, the interpolated axes must be set as 0 (linear axis (finite length)) in the Axis Feeding Mode parameters.

For information on the setting method for the Axis Feeding Mode parameter, refer to *Command Position Unit Setting* on page 6-40.

You can use the following methods to specify circular interpolation.

Command method	Description
Circular Center Specification	This method uses the present position as the start point and the specified end point, center point, and rotation direction to perform circular interpolation.
Radius Specification	This method uses the present position as the start point and the specified end point, radius, and rotation direction to perform circular interpolation. If you specify the same position as the start point and end point, an error will occur.
Passing Point Specification	This method uses the present position as the start point and the specified end point and passing point to perform circular interpolation. Specifying 3 points, namely the start point, passing point and end point, determines the rotation direction. Therefore, the specification of circular direction is ignored. If the start point and end point are the same, however, the rotation direction is not determined and thus follows the circular direction.

The rotation direction is given as the coordinate path direction on the vertical or horizontal axis. For an arc, the axis with the highest priority is the horizontal axis.

The axes in order of highest priority are as follows: configuration axis 1 > configuration axis 2 > configuration axis 3 > configuration axis 4.

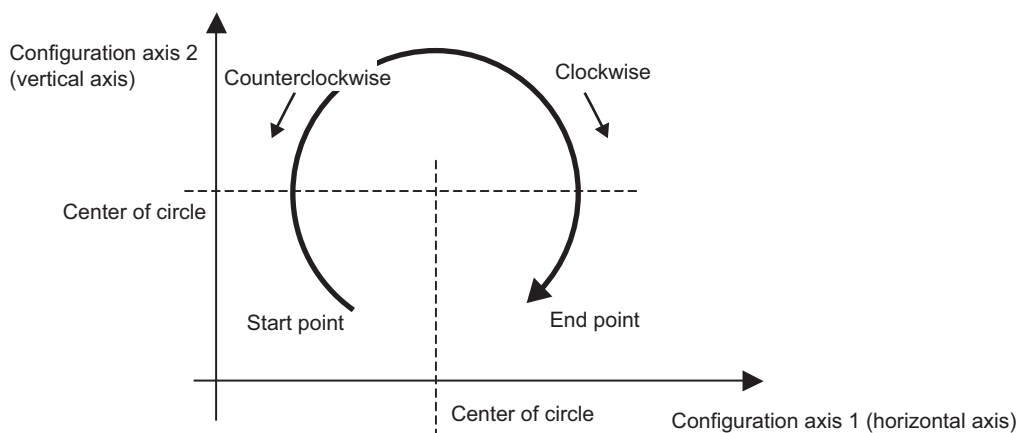

Precautions for Correct Use

- ♦ The Operation Flags, Acceleration Flags, Constant Speed Flags, Deceleration Flags, and other status for interpolated axes is not the status of the individual axes, but the status of the interpolation path.
Therefore, all interpolated axes have the same status during interpolation.
- ♦ An attempt to execute circular interpolation will cause an error and fail if a limit input of any one of the configuration axes within the task is ON.



Reference

If the start point and end point are clear and you want to perform circular interpolation to avoid something, specifying the center of the circle is useful.

Normally, the center point is calculated to perform complete circular operation for circular center specification.

When using circular interpolation to avoid something, however, it is difficult to calculate the center point accurately, although the start point and end point are clear.

If the center point is not specified accurately, however, the PCU calculates the average of two radii, namely the radius of specified center point to the start point and the radius of specified center point to the end point, and then recalculates the center point from those radii to perform circular interpolation. The specified rotation direction is maintained.

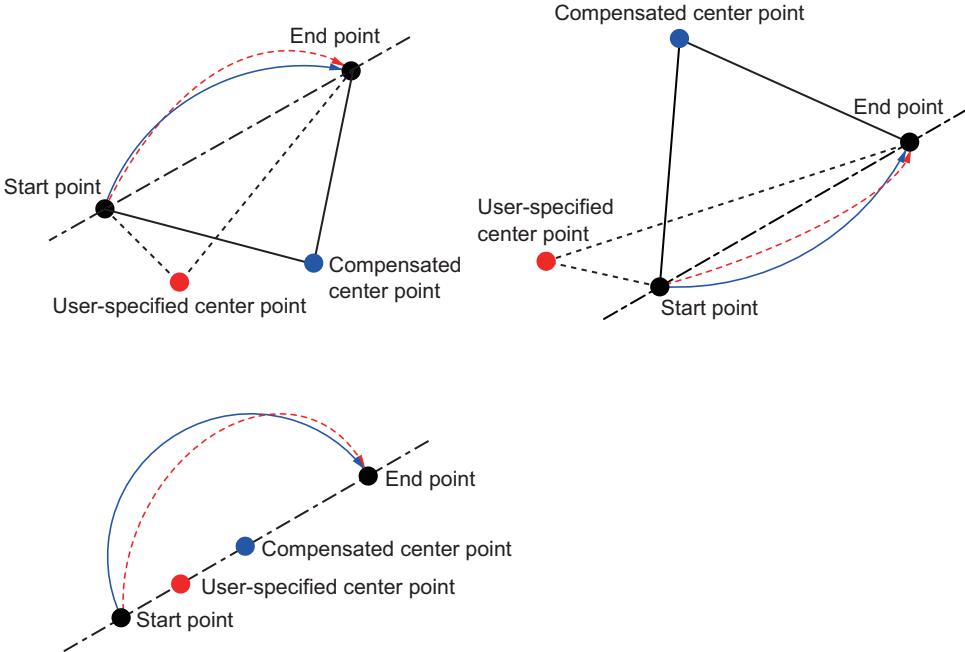

8-6 Timing Charts

This section provides timing charts, using axis 1 as an example.

Preparations for Operation

This section describes the Sequence Number Enable Bit and Memory Operation Enabled Flag, which are used before executing memory operation.

Sequence Number Enable Bit

Use the Sequence Number Enable Bit to specify the sequence from which to start operation. First, set the Sequence Number in memory and turn ON the Sequence Number Enable Bit. Then, turn ON the Memory Operation Individual Start Bit or Memory Operation Start Bit to start memory operation from the specified sequence.

A timing chart for axis 1 for the following end pattern settings in the sequence data is shown below:

Continuous 1 for sequences 10 and 20, automatic for sequence 11, END command for sequence 12, and individual for sequence 21.

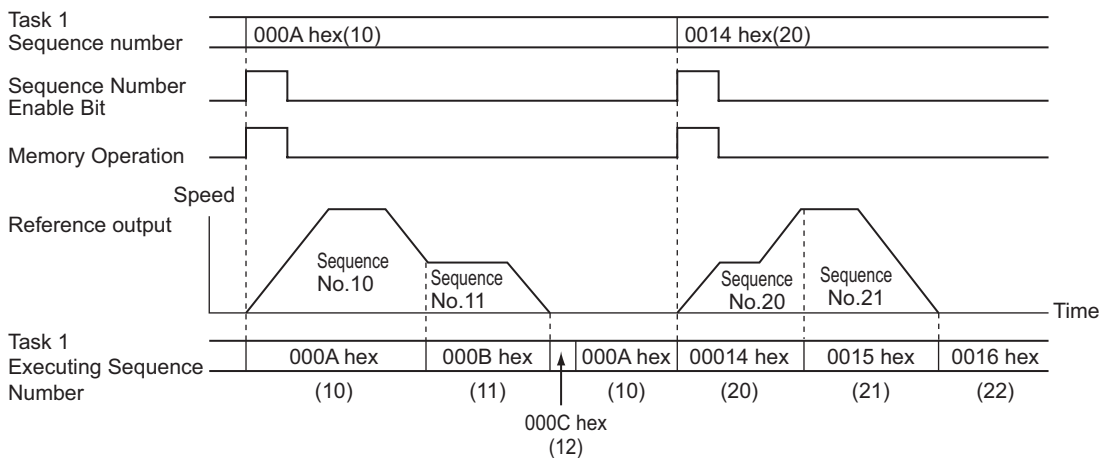

Reference

- ♦ To perform memory operation for the first time, you must set the sequence number and turn ON the Sequence Number Enable Bit.
- ♦ The sequence number is cleared when any of the following bits is turned ON: Servo Lock, Origin Search, Origin Return, or Present Position Preset.
- ♦ An error will occur if you start memory operation without specifying a sequence number.
- ♦ To start memory operation from a sequence number that is different from the executing sequence number, you must set the sequence number and turn ON the Sequence Number Enable Bit again.

Memory Operation Enabled Flag

This flag is ON while a task can be started. It is OFF while a task configuration axis is busy or a task function is being executed.

The program must be written to so that it turns ON the Memory Operation Start Bit or Memory Operation Individual Start Bit while the Memory Operation Enabled Flag is ON.

Timing Chart for Memory Operation

Memory Operation Individual Start Bits

Use the Memory Operation Individual Start Bits if you need to stop after each sequence.

With Memory Operation Individual Start Bits, the end pattern is always treated as individual regardless of the pattern that is set in the sequence data, and therefore operation stops after each sequence.

Use the Memory Operation Individual Start Bit to debug sequences one at a time.

A timing chart for axis 1 for the following end pattern settings in the sequence data is shown below: Continuous 1 for sequences 1 and 10, automatic for sequence 2, and individual for sequence 11.

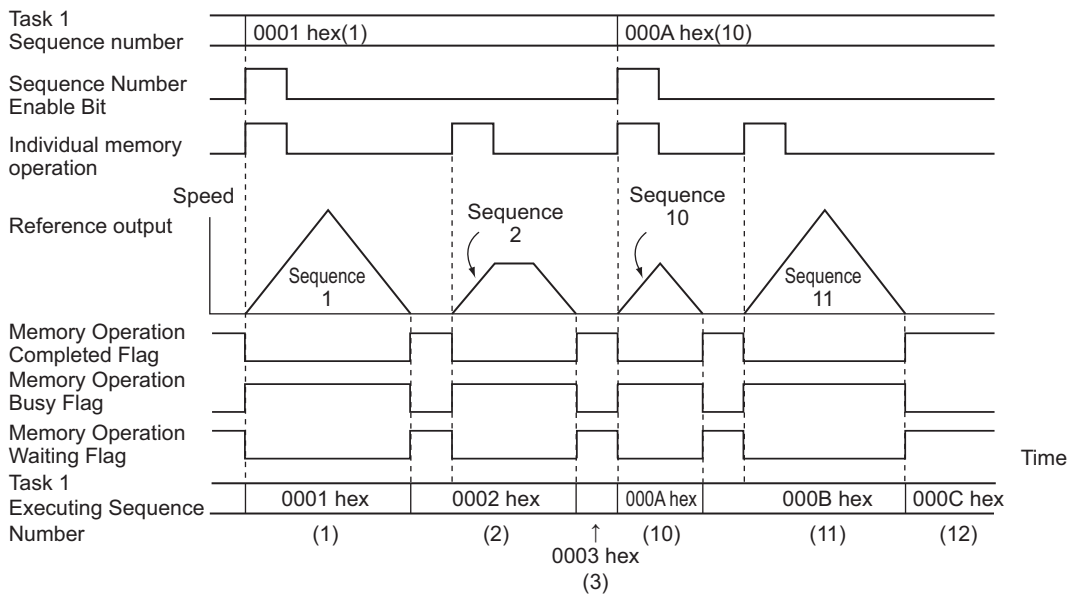

8-6 Timing Charts

If you execute individual starts for memory operation again while the Sequence Number Enable Bit is OFF, the sequence number to be executed changes as described in the following table.

Condition immediate before		Memory Operation Individual Start Bit turns ON while Sequence Enable Bit is OFF.
Start	End pattern	
Memory Operation Individual Start Bit	Individual, Automatic, or Continuous 1 to 3	Last executed sequence number + 1
Memory Operation Start Bit	Individual	Last executed sequence number + 1
	Automatic or Continuous 1 to 3	Stopping never occurs under this condition.
END command		Sequence number that was effective when you last turned ON the Sequence Number Enable Bit
Deceleration stop		The sequence number for which operation stopped is executed again.

Memory Operation

Memory operation is executed from the specified sequence according to the end pattern for each sequence. If you execute a sequence number whose end pattern is set to Individual, operation stops upon completion of positioning.

The sequence number is updated to the next number, so the next sequence is executed when the Memory Operation Start Bit is turned ON again.

A timing chart for axis 1 for the following end pattern settings in the sequence data is shown below: Continuous 1 for sequences 1 and 4, individual for sequence 2, automatic for sequences 3 and 5, and END command for sequence 6.

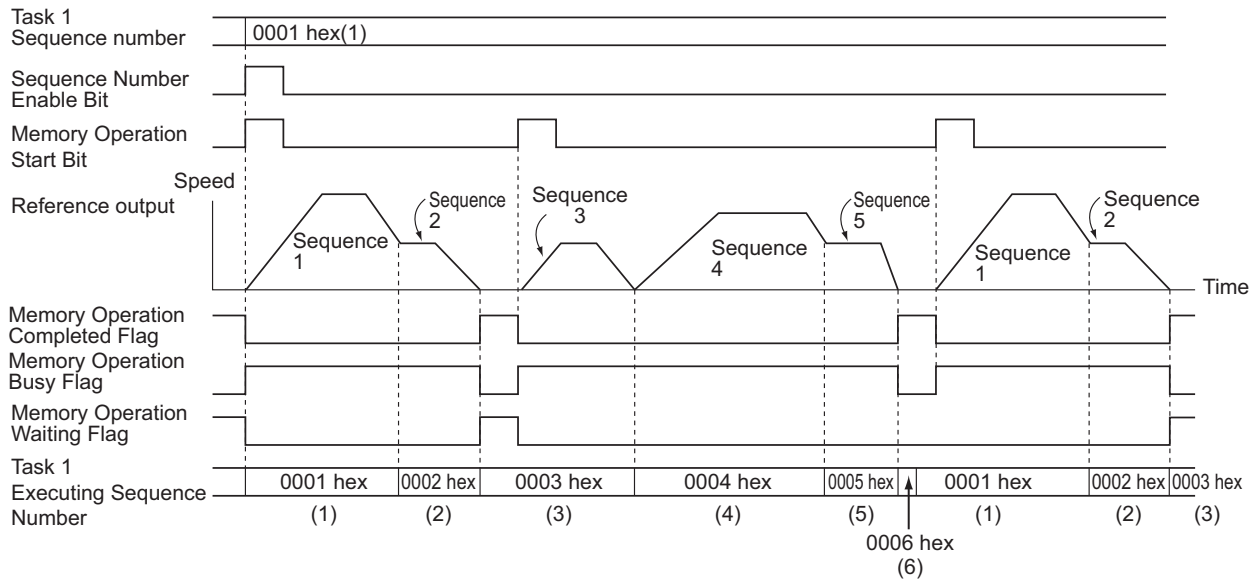

If you execute memory operation again while Sequence Number Enable Bit is OFF, the sequence number that is executed is the same as for a Memory Operation Individual Start Bit.



Reference

- The Positioning Operation Completed Flag in the Axis Status Memory Area does not change during memory operation. Use the Memory Operation Completed Flag or the M Code in the Memory Operation Status Memory Area to check the completion of the memory operation.

Timing of Data Changes

You can change the position data, speed data, acceleration time, and other sequence data during memory operation.

If the end pattern is set to continuous 1 to 3, however, changing the data may be delayed.

For a succession of sequence data with continuous 1 to 3 end patterns, up to five sets of sequence data, which include the current sequence data, are read in advance. Therefore, changes that you make to the fifth or subsequent sequences from the current sequence will be made. If you change any earlier sequences, the changes are made when you execute the sequence again.

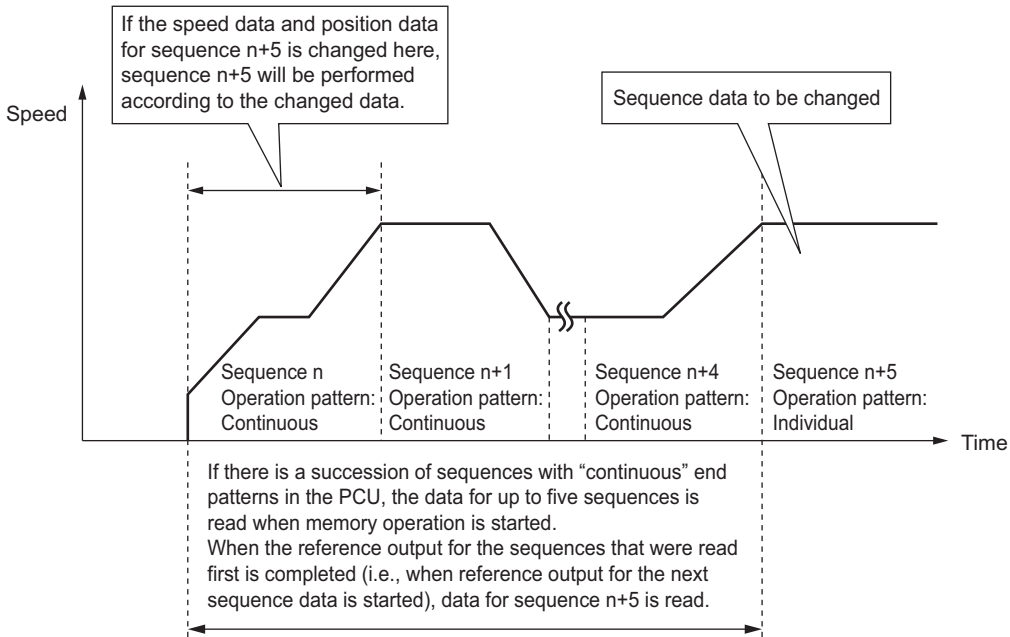

8-7 Acceleration/Deceleration

The operation of the acceleration time and deceleration time that is specified in the sequence data is determined by the setting of the Acceleration/Deceleration Time Selection axis parameter. Similarly, the operation of the interpolated acceleration time and interpolated deceleration time is determined by the setting of the Interpolation Acceleration/Deceleration Time Selection in the sequence data.

If you specify 0 (constant acceleration/deceleration rate) for the Acceleration/Deceleration Time Selection or Interpolation Acceleration/Deceleration Time Selection, the acceleration time is the time required to reach the maximum speed from the starting speed, and the deceleration time is the time required to decelerate from the starting speed from the maximum speed. If you specify 1 (Constant Acceleration/Deceleration Time), the acceleration time and deceleration time are the times required to reach the target speed from the present speed.

This section describes the acceleration time and deceleration time when you specify 0 (constant acceleration/deceleration rate) for the Acceleration/Deceleration Time Selection or Interpolation Acceleration/Deceleration Time Selection.

Calculation of Basic Acceleration/Deceleration Time

Acceleration time T1 and deceleration time T2 are determined by the following formulas:

$$\text{Acceleration time } T1 = (V1 - V0) / (Vmax - V0) \times Ta$$

$$\text{Deceleration time } T2 = (V1 - V0) / (Vmax - V0) \times Td$$

- ◆ Parameters: The following two axis parameters are used.
 - ◆ Maximum Speed: Vmax (pps)
 - ◆ Starting Speed: V0 (pps)
- ◆ Data: The following four values are specified in the Direct Operation Output Command Memory Area.
 - ◆ Command Position
 - ◆ Command Speed: V1 (pps)
 - ◆ Acceleration Time: Ta (ms)
 - ◆ Deceleration Time: Td (ms)

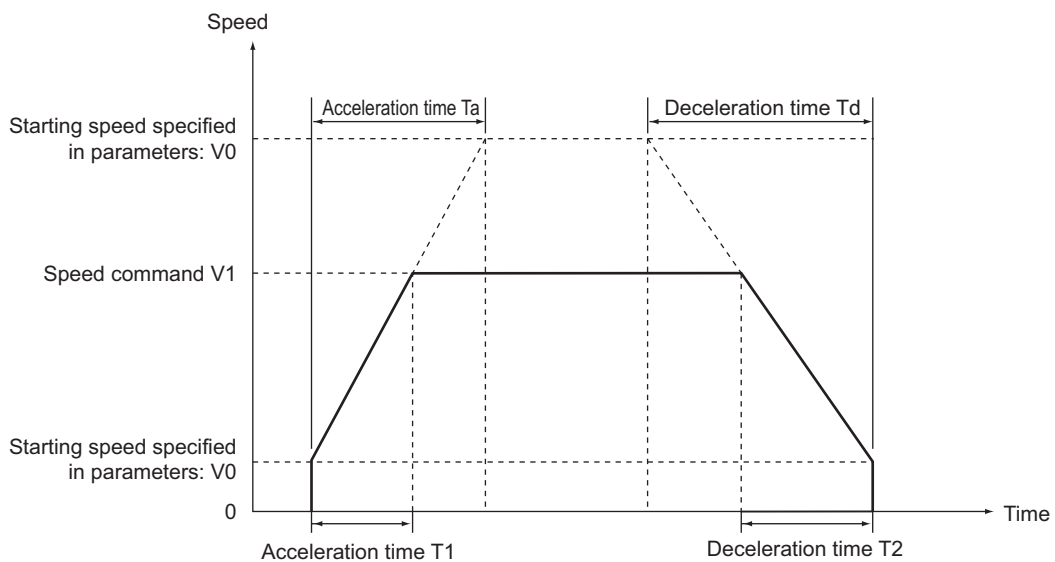

Reference

- ◆ The command speed is calculated as follows when an override is enabled:
 Command speed = Command speed in Direct Operation Command Memory Area ×
 Override in Manual Operation Command Memory Area/100

Calculation of Acceleration/Deceleration Time in Continuous Positioning

The following example assumes that the end pattern of sequence data is set to continuous 1. Calculation formulas for acceleration time and deceleration time are given for execution of sequences 0 to 2.

$$\text{Acceleration time } T1 = (V1 - V0)/(V_{\text{max}} - V0) \times Ta1$$

$$\text{Acceleration time } T2 = (V2 - V1)/(V_{\text{max}} - V0) \times Ta1$$

$$\text{Deceleration time } T3 = (V2 - V3)/(V_{\text{max}} - V0) \times Td2$$

$$\text{Deceleration time } T4 = (V3 - V0)/(V_{\text{max}} - V0) \times Td3$$

- ◆ Parameters: The following two axis parameters are used.
 - ◆ Maximum Speed: V_{max} (pps)
 - ◆ Starting Speed: $V0$ (pps)
- ◆ The following values are specified in the sequence data

No.0	<ul style="list-style-type: none"> ◆ Command Position ◆ Starting Speed: $V0$ (pps) ◆ Command Speed: $V1$ (pps) ◆ Acceleration Time: $Ta1$ (ms) ◆ Deceleration Time: $Td1$ (ms)
No.1	<ul style="list-style-type: none"> ◆ Command Position ◆ Starting Speed: $V0$ (pps) ◆ Command Speed: $V2$ (pps) ◆ Acceleration Time: $Ta2$ (ms) ◆ Deceleration Time: $Td2$ (ms)
No.2	<ul style="list-style-type: none"> ◆ Command Position ◆ Starting Speed: $V0$ (pps) ◆ Command Speed: $V3$ (pps) ◆ Acceleration Time: $Ta3$ (ms) ◆ Deceleration Time: $Td3$ (ms)

8-7 Acceleration/Deceleration

For a continuous 1 end pattern, the acceleration time or deceleration time for the present sequence is used until the sequence changes to the next one, as shown by the above calculation formulas.

If the speed in the next sequence to be executed is higher than the present speed, the acceleration time is used. If the speed for the next sequence data to be executed is lower than the present speed, the deceleration time is used.

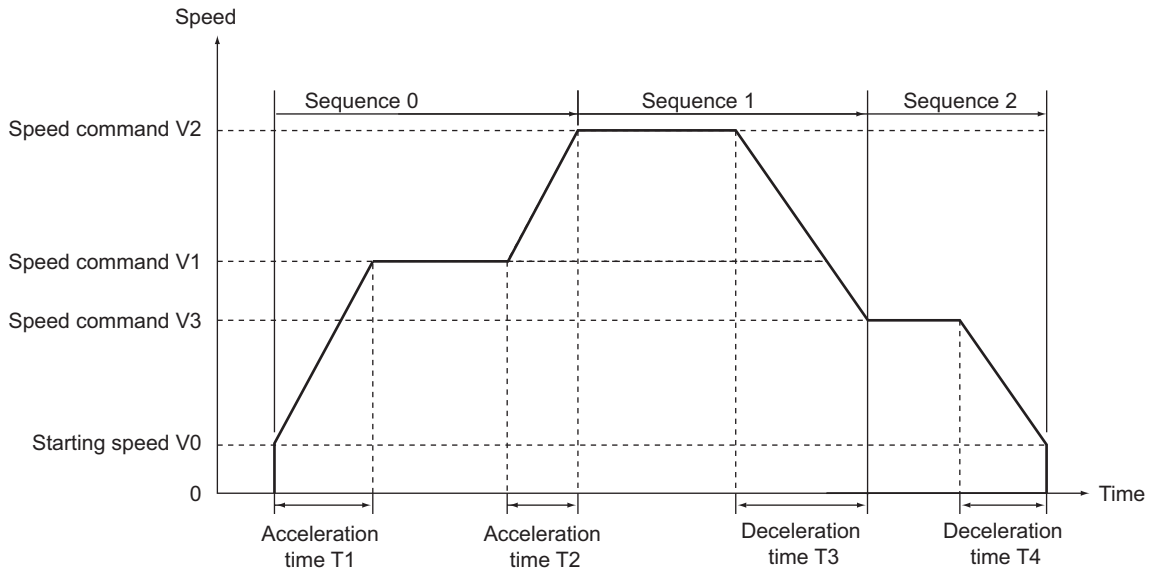

8-8 Programming Example

This section shows programming examples in which the axis is started for the operation specified below. These examples use only axis 1 in task 1.



Reference

- In this programming example, only the necessary parameters are changed and the default values are used for the rest of the parameters. The operation below may not be achieved if you change any other parameters.

Programming Example 1

Set the mechanical configuration and machine movement as described below.

Mechanical Configuration

- Set the encoder resolution to 2,000 pulses/rotation.
- Use a Servomotor with a rated speed of 3,000 r/min.
- The workpiece advances by 5 mm per motor rotation.
- Use mm as the unit and execute commands in units of 0.01 mm.

Machine Movement

- Position axis 1 to 150.00 mm at a speed of 250 mm/s by relative movement and then move the axis to 100.00 mm at a speed of 100 mm/s to complete positioning.
- Output M code 500 during low-speed movement.
- Set the maximum speed to 250 mm/s (3,000 r/min).
- Set both the acceleration time and deceleration time to 0.1 s and set constant acceleration.
- To use a Servomotor, set the starting speed to 0.
- Use Automatic as the end pattern.
- Set the Manual Operation Command Memory Area to start at W000, the Memory Operation Command Memory Area to start at W120, and the Memory Operation Status Memory Area to start at W140.
- Do not change the speed by using an override.

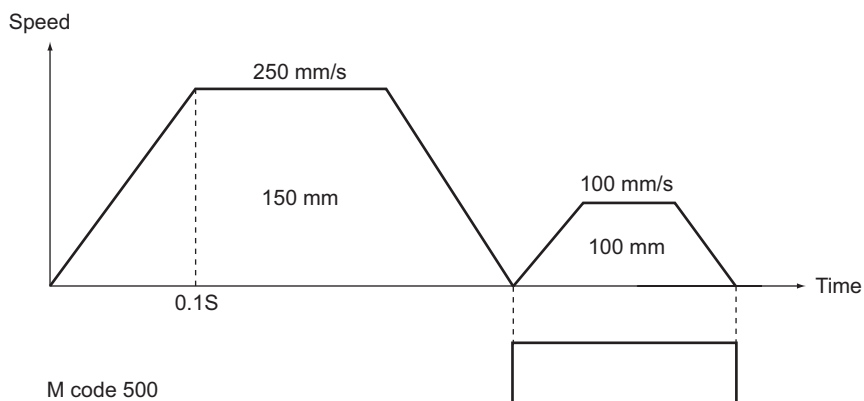

Changing of Common Parameters

Set these three parameters: Manual Operation Command Memory Area, Memory Operation Command Memory Area, and Memory Operation Status Memory Area. For details on common parameters, refer to 6-3 *Common Parameters* on page 6-15.

The required parameters are changed according to the operation.

Parameter changes are made only for task 1 and axis 1.

Settings in the Manual Operation Command Memory Area

Set the first word of the Manual Operation Command Memory Area to W000.

When you set this area in the common parameters, the Manual Operation Command Memory Area will be allocated as shown below.

Words	Name	Bit	Bit name
W000	Axis 1 Manual Operation Command Bits	0	Servo Lock Bit
		1	Drive Alarm Reset Bit
		2	Deviation Counter Reset Bit
		3	Forward Torque Limit Bit
		4	Reverse Torque Limit Bit
		5	Override Enable Bit
		6	Jogging/Inching Speed Selection Bit
		7	Forward Jogging/Inching Bit
		8	Reverse Jogging/Inching Bit
		9	Not used.
		10	Origin Search Bit
		11	Origin Return Bit
		12	Not used.
		13	Immediate Stop Bit
14	Deceleration Stop Bit		
15	Servo Unlock Bit		
W001	Axis 1 Override	0 to 15	—

Memory Operation Command Memory Area

Set the first word of the Memory Operation Command Memory Area to W120.

When you set this area in the common parameters, the Memory Operation Command Memory Area will be allocated as shown below.

Words	Name	Bit	Bit name	Function
W120	Task 1 Memory Operation Command Bits	0	Sequence Number Enable Bit	Turn ON this bit to enable the sequence number set in the operation data area when memory operation starts.
		1	Memory Operation Start Bit	Turn ON this bit to start memory operation.
		2	Memory Operation Individual Start Bit	All sequences will be executed as independent operations, except when the command is set to END.
		3	Not used.	Do not use.
		4	M Code Reset Bit	Turn ON this bit to reset the M code.
		5	Teaching Bit	Turn ON this bit to perform teaching.
		6 to 14	Not used.	Do not use.
		15	Memory Operation Stop Bit	Turn ON this bit to decelerate memory operation to a stop.
W121	Task 1 Sequence Number	0 to 15	Specify the starting sequence number for memory operation.	
W122	Task 1 Teaching Address	0 to 15	Set the position data number (sequence number) to use for position teaching in hexadecimal.	

Memory Operation Status Memory Area

Set the first word of the Memory Operation Status Memory Area to W140.

When you set this area in the common parameters, the Memory Operation Status Memory Area will be allocated as shown below.

Words	Name	Bit	Bit name	Function
W140	Task 1 Memory Operation Command Acknowledged Flags	0	Sequence Number Enable Acknowledged Flag	This flag turns ON to acknowledge the Sequence Number Enable Bit.
		1	Memory Operation Start Acknowledged Flag	This flag turns ON to acknowledge the Memory Operation Start Bit.
		2	Memory Operation Individual Start Acknowledged Flag	This flag turns ON to acknowledge the Memory Operation Independent Start Bit.
		3	Not used.	Do not use.

8-8 Programming Example

Words	Name	Bit	Bit name	Function
W140 (continued)	Task 1 Memory Operation Command Acknowledged Flags	4	M Code Reset Acknowledged Flag	This flag turns ON to acknowledge the M Code Reset Bit.
		5	Teaching Acknowledged Flag	This flag turns ON to acknowledge the Teaching Bit.
		6 to 14	Not used.	Do not use.
		15	Memory Operation Stop Acknowledged Flag	This flag turns ON to acknowledge the Memory Operation Stop Bit.
W141	Task 1 Memory Operation Command Status	0	Memory Operation Busy Flag	This flag is ON while a task command is being executed. It remains ON while a task configuration axis is busy or a task function is being executed.
		1	Memory Operation Start Enabled Flag	This flag is ON while a task can be started. It is OFF while a task configuration axis is busy or a task function is being executed.
		2 to 3	Not used.	Do not use.
		4	Memory Operation Stop Input Flag	This flag is ON while decelerating after receiving a memory operation stop command. Start commands will not be acknowledged while this flag is ON.
		5 to 7	Not used.	Do not use.
		8	Memory Operation Start Invalid Flag	This flag turns ON when an error, such as a memory operation multi-start error, occurs after execution of a command for memory operation due to an invalid execution condition or command value.
		9	Teaching Invalid Flag	This flag turns ON when the PCU could not acknowledge a teaching command.
		10 to 11	Not used.	Do not use.
		12	Memory Operation Stop Executed Flag	This flag turns ON when memory operation has stopped after receiving a memory operation stop command, after an error stop, or after receiving a command accompanied by a single-axis stop during memory operation.
		13	Memory Operation Completed Flag	This flag turns ON when memory operation has stopped normally.
		14	Teaching Completed Flag	This flag turns ON when a teaching command is completed.
15	Not used.	Do not use.		

Words	Name	Bit	Bit name	Function
W142	Task 1 Memory Operation Control Status	0	Memory Operation Stopped Flag	This flag is ON while memory operation is not being executed.
		1	Memory Operation Waiting Flag	This flag is ON while memory operation is on standby. It turns ON when memory operation stops without executing END.
		2	Memory Operation Axis Operating Flag	This flag is ON while an axis is operating during memory operation. It is ON while any configuration axis is operating.
		3	Condition Input Waiting Flag	This flag is ON while the PCU is waiting for the input of conditions during memory operation.
		4	Dwell Timer Waiting Flag	This flag is ON while the PCU is waiting for the dwell time during memory operation.
		5	M Code Reset Waiting Flag	This flag is ON while the PCU is waiting for the M code to be reset during memory operation.
		6	M Strobe Flag	This flag is ON while there is an M code output during memory operation.
		7 to 9	Not used.	Do not use.
		10	Memory Operation Execution Error Flag	This flag turns ON when an operation error occurs for the task function.
		11	Memory Operation Warning Flag	This flag turns ON when a warning occurs in memory operation.
		12	Memory Operation Error Flag	This flag turns ON when a memory operation error occurs.
		13 to 15	Not used.	Do not use.
W143	Task 1 Memory Operation Error Code	0 to 15	This word contains the memory operation error code.	
W144	Task 1 Executing Sequence Number	0 to 15	This word contains the number of the sequence that is being executed in memory operation.	
W145	Task 1 M Code	0 to 15	This word contains the M code (output code) for memory operation.	

Changing Axis Parameters

First, change the Command Position Unit Setting parameter. For details, refer to *Command Position Unit Setting* on page 6-40.

Set the parameters as follows according to the mechanical configuration.

Parameter name	Function	Set value	Unit
Displayed Unit	Select the unit for command values. 0: Pulses, 1: mm, 2: Degrees, 3: Inches	1	–
Command Pulses Count Per Motor Rotation	Set the number of pulses per motor rotation.	2,000	Pulse
Work Travel Distance Per Motor Rotation	Set the amount of workpiece movement per motor rotation.	5	Displayed Unit [mm]
Unit Multiplier	Set the ratio relative to the amount of the workpiece movement when the motor makes 1 rotation. 0: x1, 1: x10, 2: x100, 3: x1,000, 4: x10,000	2*1	–

*1. This setting sets 0.01 mm as the command unit.

Next, change the acceleration/deceleration settings. For more information, refer to *Acceleration/Deceleration Settings* on page 6-36.

Similarly, set the following parameters according to the mechanical configuration.

Parameter name	Function	Set value	Unit
Maximum Speed	Specify the maximum speed for the axis.	25,000	Command units/s (0.01 mm/s)
Starting Speed	Specify the starting speed for the axis.	0	Command units/s (0.01 mm/s)
Acceleration/Deceleration Time Selection	Set how to specify the acceleration/deceleration time. 0: Time from starting speed to maximum speed of each axis (constant acceleration/deceleration rate) 1: Time from present speed to target speed of each axis (constant acceleration/deceleration time)	0	–



Reference

Because the maximum speed was changed to 250.00 mm/s, the default values for the origin search speed, jogging/inching speed, and other speed-related parameters may exceed the maximum speed. For those parameters that exceed the maximum speed, set the values to the maximum speed or lower.

Changes to Memory Operation Parameters

Select the configuration axes for the task. Use task 1 to operate only axis 1.
For details, refer to *Configuration Axes* on page 6-72.

Parameter name	Function	Set value	Unit
Configuration Axes ^{*1}	Select the configuration axes for the task. Bit 00: Turn ON to use axis 1. Otherwise turn OFF. Bit 01: Turn ON to use axis 2. Otherwise turn OFF. Bit 02: Turn ON to use axis 3. Otherwise turn OFF. Bit 03: Turn ON to use axis 4. Otherwise turn OFF. Bit 04: Turn ON to use axis 5. Otherwise turn OFF. Bit 05: Turn ON to use axis 6. Otherwise turn OFF. Bit 06: Turn ON to use axis 7. Otherwise turn OFF. Bit 07: Turn ON to use axis 8. Otherwise turn OFF. Bit 08: Turn ON to use axis 9. Otherwise turn OFF. Bit 09: Turn ON to use axis 10. Otherwise turn OFF. Bit 10: Turn ON to use axis 11. Otherwise turn OFF. Bit 11: Turn ON to use axis 12. Otherwise turn OFF. Bit 12: Turn ON to use axis 13. Otherwise turn OFF. Bit 13: Turn ON to use axis 14. Otherwise turn OFF. Bit 14: Turn ON to use axis 15. Otherwise turn OFF. Bit 15: Turn ON to use axis 16. Otherwise turn OFF.	0001 hex	—

*1. Up to four axes can be selected for one task. An error will occur if more than four axes are selected.

Memory Operation Data Settings

Set data for sequences 1 and 2 according to the operation.

Data for Sequence 1

Set the sequence data for moving the axis to 150.00 mm at a speed of 250 mm/s for the movement of the machine.

Data name	Function	Set value	Unit
Configuration Axis 1 Command Position	Set the command position data for configuration axis 1.	15,000	Command units (0.01 mm)
Command	Select Positioning Operation.	—	—
Sequence Start Condition	Use a memory operation condition data number to set the skip condition. Set No Start Condition.	0	—
Sequence Skip Condition	Use a memory operation condition data number to set the skip condition. Set No Condition.	0	—

8-8 Programming Example

Data name	Function	Set value	Unit
End Pattern	Set the operation end pattern. 0: Individual 1: Automatic 2: Continuous 1 (Until the next sequence speed) 3: Continuous 2 (Acceleration/deceleration starts at the next sequence) 4: Continuous 3 (Pass: Overlap deceleration for the present sequence and acceleration for the next sequence)	1	—
Dwell Timer	If the end pattern is set to Individual or Automatic, set the dwell time. 0: No dwell time 0.01 to 10.00 s: Dwell time (10-ms units)	0	—
Positioning Completed Input Monitor Valid	Select the positioning completed operation to use when an axis stops. 0: Do not wait for the completion of positioning 1: Wait for the completion of positioning	1	—
M Code	Set the M code for after positioning has been completed. 0: No M code 1 to 499: M codes that wait to be reset 500 to 999: M codes that do not wait to be reset	500	—
Axis Specification	Set the axes to start. A start command is sent when each bit turns ON. Bit 00: Configuration axis 1 Bit 01: Configuration axis 2 Bit 02: Configuration axis 3 Bit 03: Configuration axis 4	0001 hex	—
Position Specification	Select whether to use a relative position or absolute position for the command position. Turn OFF a bit to indicate an absolute position. Bit 00: Configuration axis 1 Bit 01: Configuration axis 2 Bit 02: Configuration axis 3 Bit 03: Configuration axis 4	0001 hex	—
Configuration Axis 1 Command Speed	Set the target speed for the axis positioning operation (PTP).	25,000	Command units/s (0.01 mm/s)
Configuration Axis 1 Acceleration Time	Set the acceleration time for positioning operation (PTP).	100	ms
Configuration Axis 1 Deceleration Time	Set the deceleration time for positioning operation (PTP).	100	ms

Data for Sequence 2

Set the sequence data for moving the axis by 100.00 mm at a speed of 100 mm/s and stopping it for the movement of the machine.

Data name	Function	Set value	Unit
Configuration Axis 1 Command Position	Set the position data.	10,000	Command units (0.01 mm)
Command	Select Positioning Operation.	–	–
Sequence Start Condition	Use a memory operation condition data number to set the skip condition. Set No Start Condition.	0	–
Sequence Skip Condition	Use a memory operation condition data number to set the skip condition. Set No Condition.	0	–
End Pattern	Set the operation end pattern. 0: Individual 1: Automatic 2: Continuous 1 (Until the next sequence speed) 3: Continuous 2 (Acceleration/deceleration starts at the next sequence) 4: Continuous 3 (Pass: Overlap deceleration for the present sequence and acceleration for the next sequence)	1	–
Dwell Timer	If the end pattern is set to Individual or Automatic, set the dwell time. 0: No dwell time 0.01 to 10.00 s: Dwell time (10-ms units)	0	–
Positioning Completed Input Monitor Valid	Select the positioning completed operation to use when an axis stops. 0: Do not wait for the completion of positioning 1: Wait for the completion of positioning	1	–
M Code	Set the M code for after positioning has been completed. 0: No M code 1 to 499: M codes that wait to be reset 500 to 999: M codes that do not wait to be reset	0	–
Axis Specification	Set the axes to start. A start command is sent when each bit turns ON. Bit 00: Configuration axis 1 Bit 01: Configuration axis 2 Bit 02: Configuration axis 3 Bit 03: Configuration axis 4	0001 hex	–
Position Specification	Select whether to use a relative position or absolute position for the command position. Turn OFF a bit to indicate an absolute position. Bit 00: Configuration axis 1 Bit 01: Configuration axis 2 Bit 02: Configuration axis 3 Bit 03: Configuration axis 4	0001 hex	–

8-8 Programming Example

Data name	Function	Set value	Unit
Configuration Axis 1 Command Speed	Set the target speed for the axis positioning operation (PTP).	10,000	Command units/s (0.01 mm/s)
Configuration Axis 1 Acceleration Time	Set the acceleration time for positioning operation (PTP).	100	ms
Configuration Axis 1 Deceleration Time	Set the deceleration time for positioning operation (PTP).	100	ms

Data for Sequence 3

Set an END command in this sequence.

Data name	Function	Set value	Unit
Command	Select END.	–	–
Sequence Start Condition	Use a memory operation condition data number to set the skip condition. Set No Start Condition.	0	–

Ladder Program

The following figure shows the ladder diagram for this example.

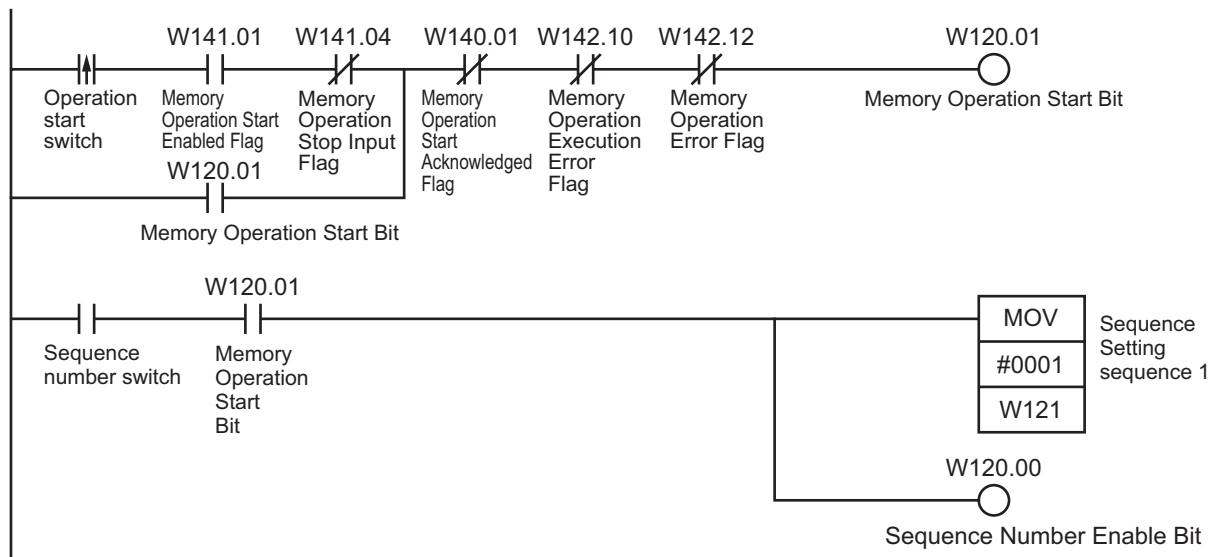

Programming Example 2

This programming example shows how to start operation with the PCU POSITIONING TRIGGER instruction (NCDTR) when starting with a command is specified as the sequence start condition in memory operation.

This example assumes that the unit number of the PCU is set to 0.



Precautions for Correct Use

To use the PCU POSITIONING TRIGGER instruction (NCDTR(219)), the PCU must be used together with a CJ2M or CJ2H CPU Unit with unit version 1.3 or later.

Mechanical Configuration

- ◆ Set the encoder resolution to 2,000 pulses/rotation.
- ◆ Use a Servomotor with a rated speed of 3,000 r/min.
- ◆ The workpiece advances by 5 mm per motor rotation.
- ◆ Use mm as the unit and execute commands in units of 0.01 mm.

Machine Movement

- ◆ Position axis 1 to 150.00 mm at a speed of 250 mm/s using a relative movement.
- ◆ The sequence start condition is set to use a command to start operation and then NCDTR is used to start operation when the PCU is waiting for input of the condition.

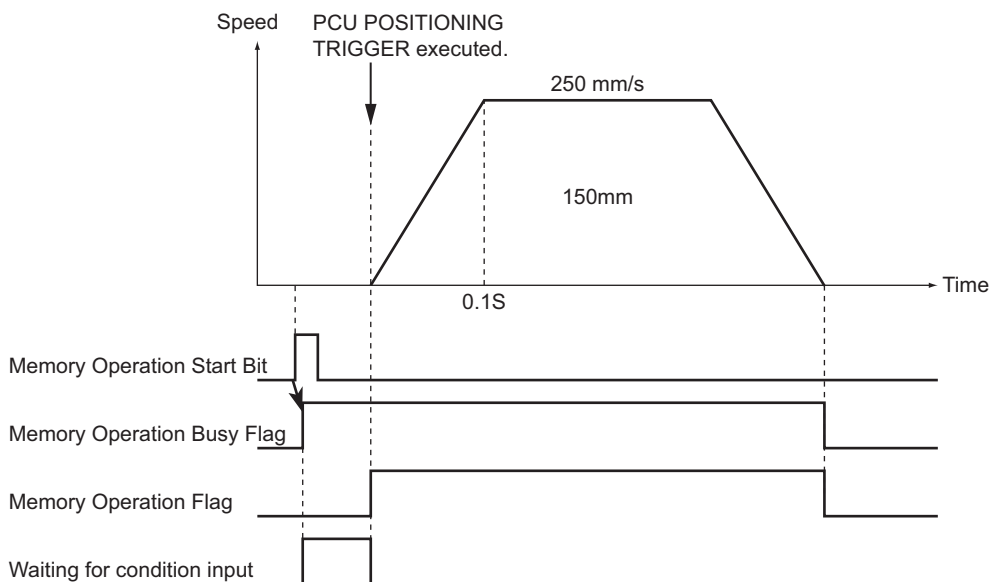

Setting Parameters

The settings of the common parameters, axis parameters, and memory operation parameters are the same as for programming example 1.

The allocations for the Manual Operation Command Memory Area, Memory Operation Command Memory Area, and Memory Operation Status Memory Area are also the same as for programming example 1.

Memory Operation Data Settings

The operation data is set in sequence 1.

Data for Sequence 1

Set the sequence data for moving the axis to 150.00 mm at a speed of 250 mm/s for the movement of the machine.

Data name	Function	Set value	Unit
Configuration Axis 1 Command Position	Set the command position data for configuration axis 1.	15,000	Command units (0.01 mm)
Command	Select Positioning Operation.	–	–
Sequence Start Condition	Use a memory operation condition data number to set the skip condition. Condition data 1 is used.	1	–
Sequence Skip Condition	Use a memory operation condition data number to set the skip condition. Set No Condition.	0	–
End Pattern	Set the operation end pattern. 0: Individual 1: Automatic 2: Continuous 1 (Until the next sequence speed) 3: Continuous 2 (Acceleration/deceleration starts at the next sequence) 4: Continuous 3 (Pass: Overlap deceleration for the present sequence and acceleration for the next sequence)	0	–
Dwell Timer	If the end pattern is set to Individual or Automatic, set the dwell time. 0: No dwell time 0.01 to 10.00 s: Dwell time (10-ms units)	0	–
Positioning Completed Input Monitor Valid	Select the positioning completed operation to use when an axis stops. 0: Do not wait for the completion of positioning 1: Wait for the completion of positioning	1	–
M Code	Set the M code for after positioning has been completed. 0: No M code 1 to 499: M codes that wait to be reset 500 to 999: M codes that do not wait to be reset	0	–

Data name	Function	Set value	Unit
Axis Specification	Set the axes to start. A start command is sent when each bit turns ON. Bit 00: Configuration axis 1 Bit 01: Configuration axis 2 Bit 02: Configuration axis 3 Bit 03: Configuration axis 4	0001 hex	—
Position Specification	Select whether to use a relative position or absolute position for the command position. Turn OFF a bit to indicate an absolute position. Bit 00: Configuration axis 1 Bit 01: Configuration axis 2 Bit 02: Configuration axis 3 Bit 03: Configuration axis 4	0001 hex	—
Configuration Axis 1 Command Speed	Set the target speed for the axis positioning operation (PTP).	25,000	Command units/s (0.01 mm/s)
Configuration Axis 1 Acceleration Time	Set the acceleration time for positioning operation (PTP).	100	ms
Configuration Axis 1 Deceleration Time	Set the deceleration time for positioning operation (PTP).	100	ms

Setting the Memory Operation Condition Data

The operation data is set in condition data 1.

Setting Condition Data 1

Select Command Start for the sequence start condition.

Ladder Program

The following figure shows the ladder diagram for this example.

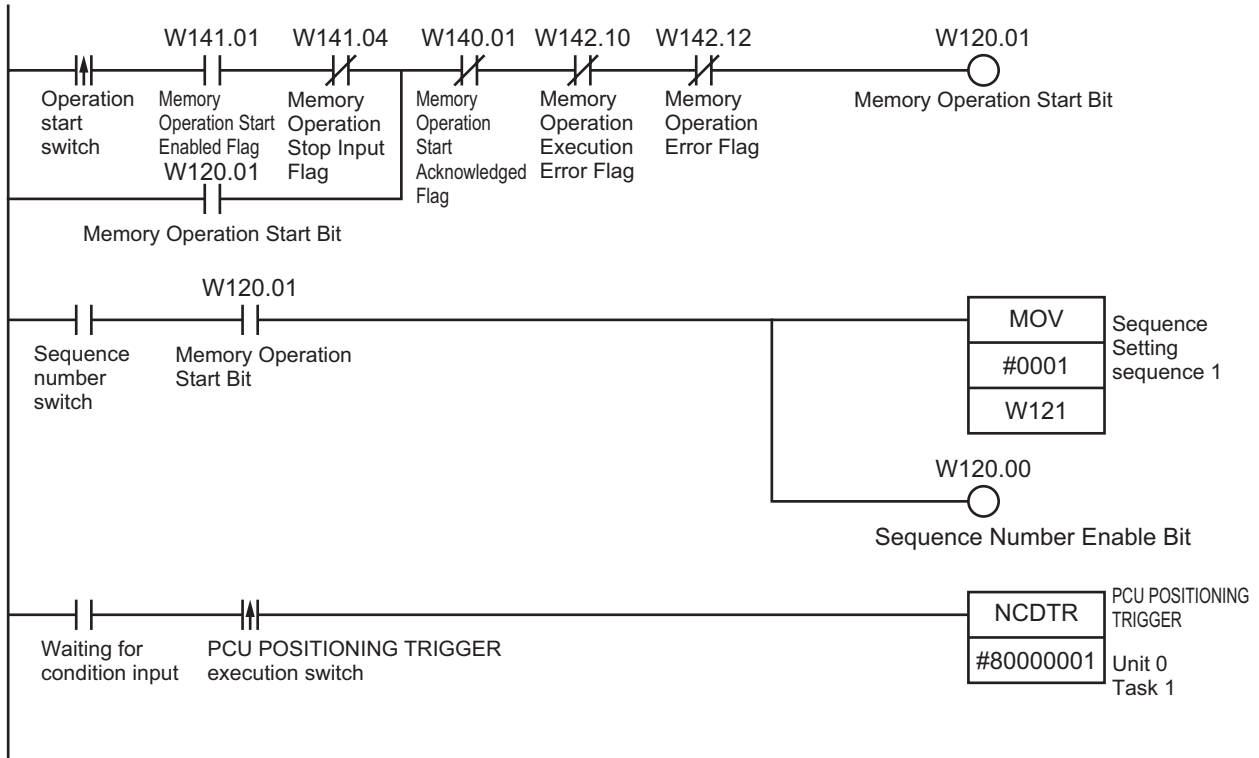

Memory Operation



8-9 Monitoring with CX-Programmer

You can use the CX-Programmer to monitor memory operation.

Monitoring Memory Operation

This section describes the monitoring procedure.

1. Connect the CX-Programmer online to the PLC.
2. Display the PCU Setting Window.
3. Select Memory Operation Monitor from the NC Unit Menu.

The following dialog box will appear, and you can monitor the operation in it.

The screenshot shows the 'Memory Operation Monitor' dialog box. The 'Error' section at the top has input fields for PCU, Task1-4, and Axis1-4, all containing '0000'. An 'Error Reset' button is located to the right. The 'Memory Operation Status' section contains four rows (01-04) for tasks. Each row has 'Stop Executed' (OFF), 'Operation Completed' (OFF), 'Sequence No.' (0000), 'M Code' (0000), and 'Maximum Deviation between Axes' (0). The 'Axis Operation Information' section contains four rows (Axis1-4) for axes. Each row has a dropdown menu (Axis1-4), 'Command Position' (0 or -1), 'Feedback Position' (0 or -1), 'Stop Completed' (OFF), and 'Positioning Operation Completed' (OFF). The 'Memory Operation Auxiliary Flag' section at the bottom has a grid of 16 flags (00-15) and a refresh button. All flags are currently OFF.

8-10 Memory Operation Preview

The memory operation preview allows you to check the suitability of the data set in a memory operation table before transferring the data to the PCU.

You can display graphs of axis positions and speeds plotted against time or paths of 2-axis interpolation.

The memory operation preview provides the following advantages.

- ♦ Malfunctions caused by setting mistakes can be prevented.
- ♦ Causes of operating problems that occur when debugging on the PCU can be easily isolated.

Procedure

Perform the following procedure to use the memory operation preview.

- 1. Create the data in the memory operation table.**
- 2. Start the memory operation preview and confirm the suitability of the data by displaying graphs of axis positions and speeds plotted against time or tracks of 2-axis interpolation.**
- 3. Correct or adjust the data.**
- 4. Confirm the data again using the memory operation preview.**

By repeating steps 3 and 4 until the data is suitable, confirmation work and time on the PCU is reduced and debugging is completed quickly.

Starting the Memory Operation Preview

There are three ways that you can use to start the memory operation preview.

Starting method 1	Select NC Unit - Memory Operation Preview from the menus.
Starting method 2	Right-click a task number in the project tree and select Memory Operation Preview from the pop-up menu.
Starting method 3	Click the Memory Operation Preview Button.

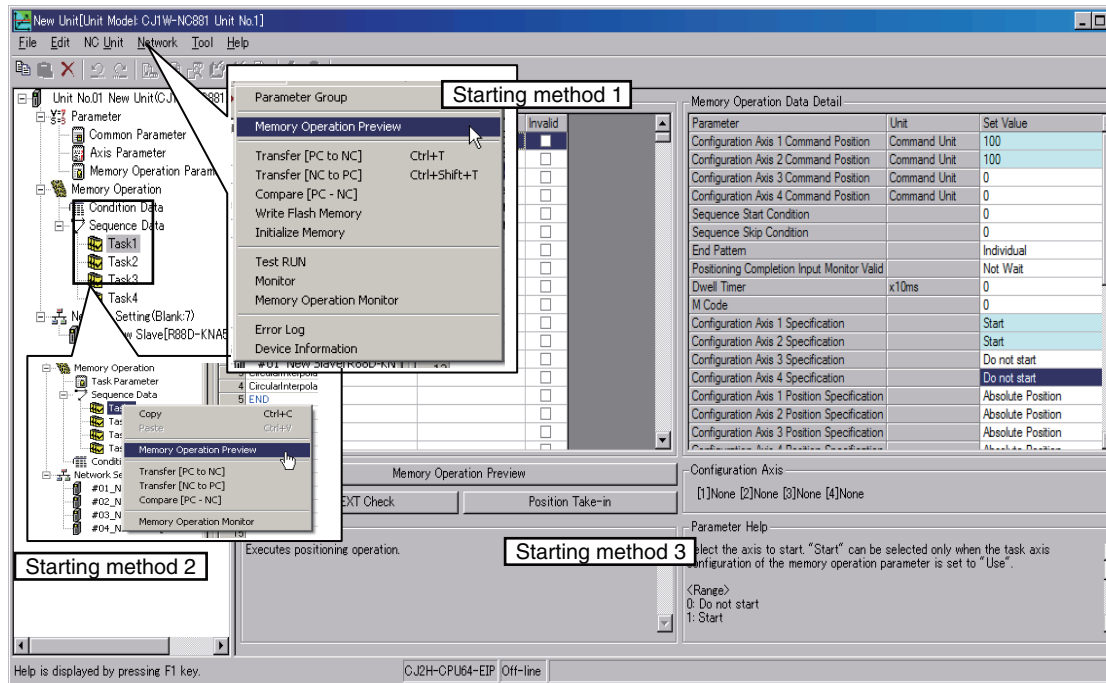

Displaying Graphs for One Axis

Changes in the position and speed of one axis over time can be checked on graphs. The sequence numbers are displayed in the graph so that you can easily compare them to the data in the memory operation table.

The screenshot shows the 'Memory Operation Preview' window. At the top, there are dropdown menus for 'Task No.' (set to 1) and 'Sequence Start No.' (set to 1). Below these are buttons for '1 axis', 'Interpolation', and '4 axes', along with a checked 'Display Sequence No.' checkbox. A dropdown menu for 'Axis:' is set to 'Axis 1'. The main area contains two graphs: 'Track' (position in mm vs. time in ms) and 'Speed' (speed in mm/s vs. time in ms). Both graphs show a pink curve with numbered markers (1-6) corresponding to sequence numbers. A 'Replay Track' control is at the bottom, featuring a slider, play/pause buttons, and a 'Sequence No.' field set to 1. Lines connect various UI elements to descriptive text on the right.

- Refreshes the graph.
- Selects the task to monitor (1 to 4).
- Inputs or selects the first sequence to monitor (1 to 500).
- Displays and hides sequence numbers in the graph.
- Changes the graphs that are displayed.
- Selects the axis to monitor.
- Displays the changes in the position and speed of the selected graph over time.*1
- Pointers are displayed.
- Described under "Track Replay."

*1 The graph will be displayed from the specified first sequence to the sequence with an END command or to the first sequence with Individual set for the end pattern. End patterns are specified in the memory operation data.

Displaying Two Interpolated Axes

Displaying two interpolated axes lets you visualize the interpolated operation, which is difficult from the memory operation table. The replay function can be used to move the pointer on the track to check movements in advance.

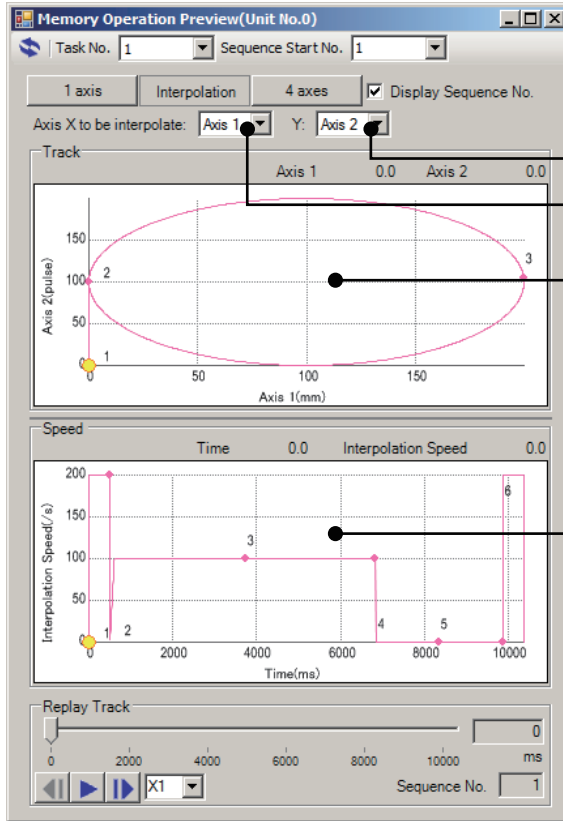

Specifies the Y axis for interpolation on the graph.

Specifies the X axis for interpolation on the graph.

Displays a graph for checking the interpolated track of the two axes specified for interpolation.

Displays a graph for checking changes in the interpolated speed of the two axes specified for interpolation.

Displaying All Axis

Changes in the positions and speeds of all axes can be lined up on the display to check the operation timing of the axes.

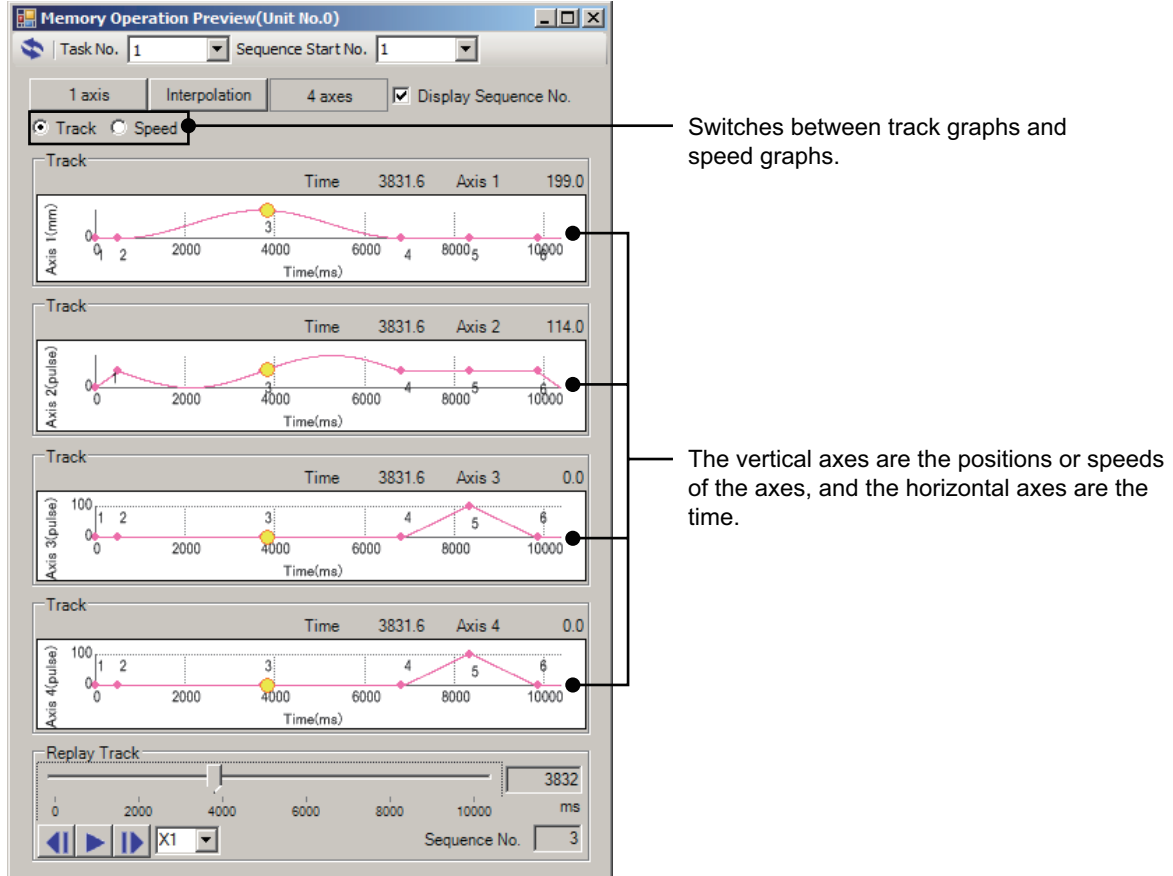

Reference

If you display a preview of more than one consecutive operation, the points are thinned when they are displayed, so the preview display may vary from the actual operations.

Operation Path Replay

Pointers that show the current location on position or speed graphs are displayed. The pointers move on the graphs as time elapses.

Automatic or Manual Replay

Pointers that show the current location on position or speed graphs are displayed. The pointers move on the graphs as time elapses.

The pointers will move automatically if you click the Replay Button (automatic replay).

When automatic replay is not in progress, you can move the cursor on the slider to replay the status at any point in time (manual replay).

The sequence number is displayed on the pointers as the pointers move on the graphs. This allows you to easily confirm the sequence number that is being replayed.

Replay Speed

A factor can be set for the speed that is used for automatic replay.

The factor is x1 when the memory operation preview is started.

The replay speed can be selected from x0.5, x1, and x2.

These will change the replay speed to half the normal speed, the normal speed, or twice the normal speed.

Frame Advance

The Frame Advance Buttons can be used to quickly move the pointers to the starting point of the next or previous sequence from the sequence where the pointers are currently displayed.

If a Frame Advance Button is pressed during automatic replay, automatic replay will be stopped and the pointers will move to the starting point of the next or previous sequence.

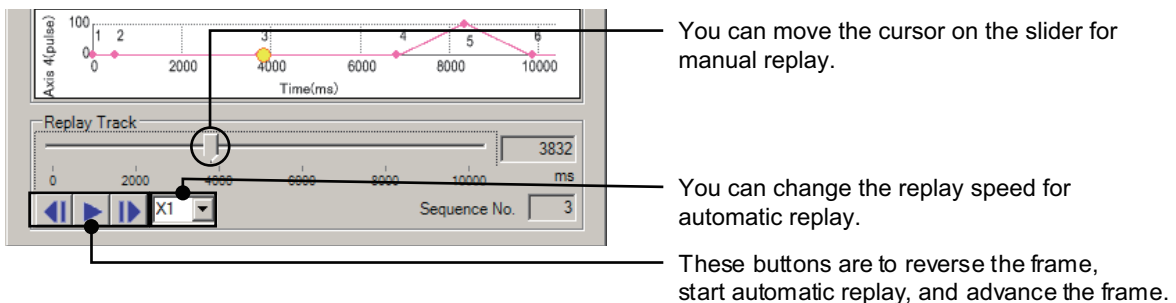

Supported Commands

The following five commands are supported for the memory operation preview.

If unsupported commands are input, a warning dialog box will appear to tell you so. The preview will be displayed from the specified first sequence number until one command before the unsupported command.

The setting of the dwell timer is not applied to memory operation preview displays.

- ◆ Positioning operation
- ◆ Linear interpolation operation
- ◆ Clockwise circular interpolation operation
- ◆ Counterclockwise circular interpolation operation
- ◆ END

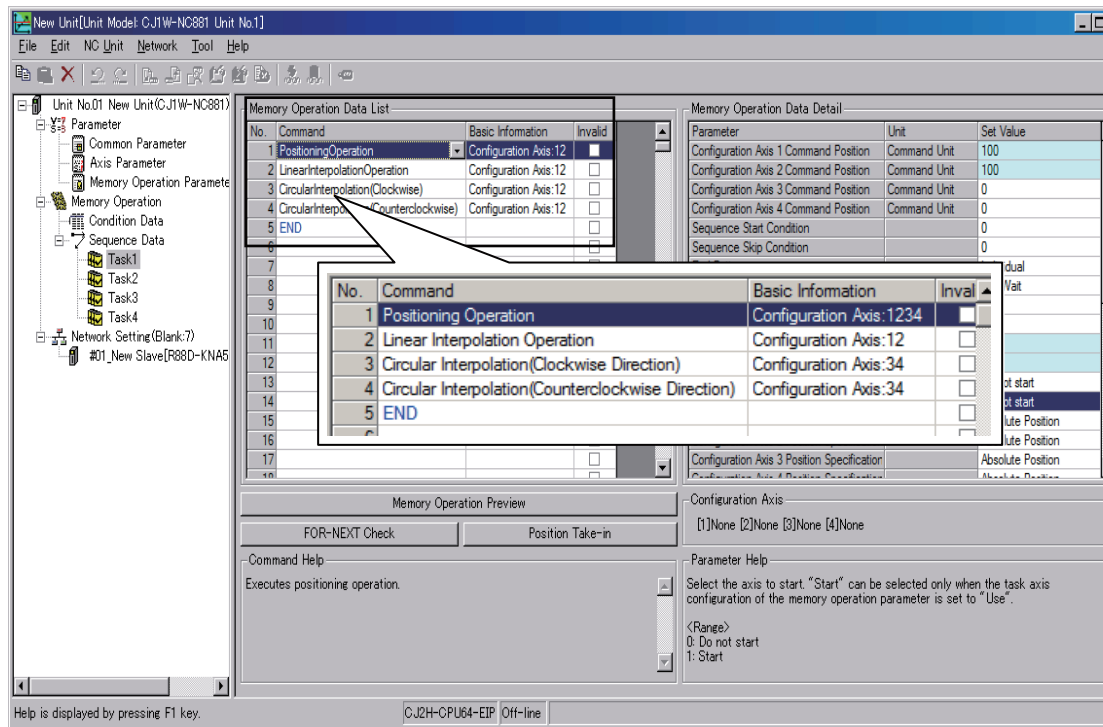

Reference

Commands without settings and NOP commands are ignored when the preview is displayed.

Error Messages

This section lists the error messages that can appear during operation and describes the remedies for them.

Message	Probable cause of error	Remedy
An error was detected during running. Sequence No. xx Error description: Memory operation data error	There is a mistake in the parameters set in the sequence data.	Correct the parameter in sequence number xx in the Memory Operation Data List.
An error was detected during running. Sequence No. xx Error description: Memory allocation failed.	There is not enough memory in the computer you are using.	Increase the amount of available memory on your computer.
Replaying speed can be scaled by a value between 0.01 and 100. (A value can be set to two places of decimals.)	A number smaller than 0.01 or larger than 100 was input in the Replay Speed Box.	Input a replay speed scale value between 0.01 and 100.
Effective sequence numbers are 1 to 500.	A number smaller than 1 or larger than 500 was input in the Sequence Start No. Box.	Input a number between 1 and 500 in the Sequence Start No. Box.
Enter a value (The value you entered has a format error.)	A character string or symbol was input in the Replay Speed Box or Sequence Start No. Box.	Input a number between 0.01 and 100 in the Replay Speed Box and a number between 1 and 500 in the Sequence Start No. Box.
Unspecified memory operation command is included. Sequence No. xx: Simulation ends at the above sequence No.	A command that is not supported for the memory operation preview is included in the memory operation data.	—

9

Transferring and Saving Data

This section describes the data transfer method from the CPU Unit of the PLC and the data transfer method with the CX-Programmer.

9-1	Outline of Data Transfer	9-1
9-2	Writing with the Data Transfer Bits	9-31
9-3	Reading with Data Transfer Bits.....	9-39
9-4	Writing Data with IOWR(223)	9-45
9-5	Reading Data with IORD(222)	9-50
9-6	Data Transfer with CX-Programmer	9-54
9-7	Saving Data	9-56
9-8	PCU Setup	9-59
9-9	Simple Backup	9-61

9-1 Outline of Data Transfer

This section describes the methods that can be used to transfer (write and read) parameters and memory operation data between the CPU Unit and the PCU.

Transfer Methods

There are three transfer methods.

Transferring Data with Data Transfer Bits

You can use data transfer bits to transfer data regard less of the operating mode of the CPU Unit. Use the data transfer bits to change or read a large volume of data.

You can transfer data by turning ON a data transfer bit with an OUTPUT instruction in the ladder diagram or by force-setting a data transfer bit.

For details, refer to 9-2 *Writing with the Data Transfer Bits* on page 9-31 and 9-3 *Reading with Data Transfer Bits* on page 9-39.

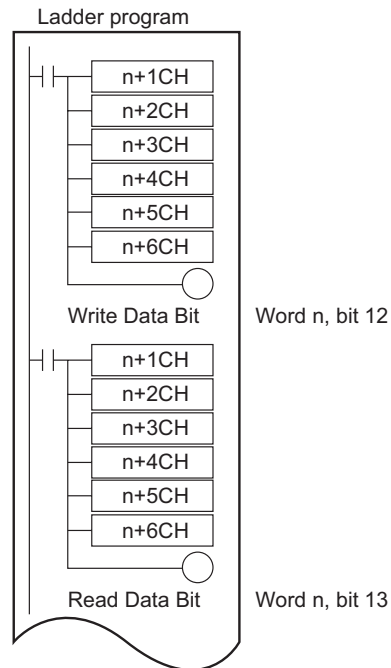
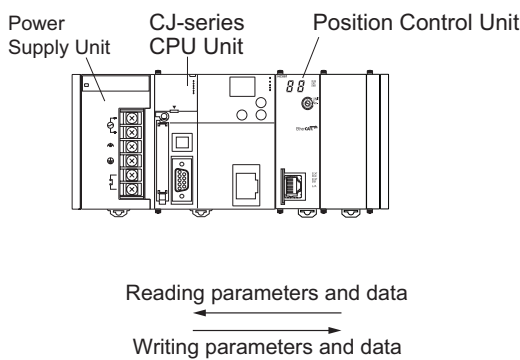

Transferring Data with IOWR(223) and IORD(222) Instructions

Data can be transferred with the IOWR(223)/IORD(222) instructions only while the CPU Unit is operating. Therefore, only data that is refreshed continuously can be transferred.

Use the IOWR(223) or IORD(222) instructions to change or read a small amount of data.

Also, memory operation data for more than one sequence cannot be transferred at the same time with the IOWR instruction. Always transfer data for only one sequence with each IOWR(223) instruction.

For details, refer to 9-4 *Writing Data with IOWR(223)* on page 9-45 and 9-5 *Reading Data with IORD(222)* on page 9-50.

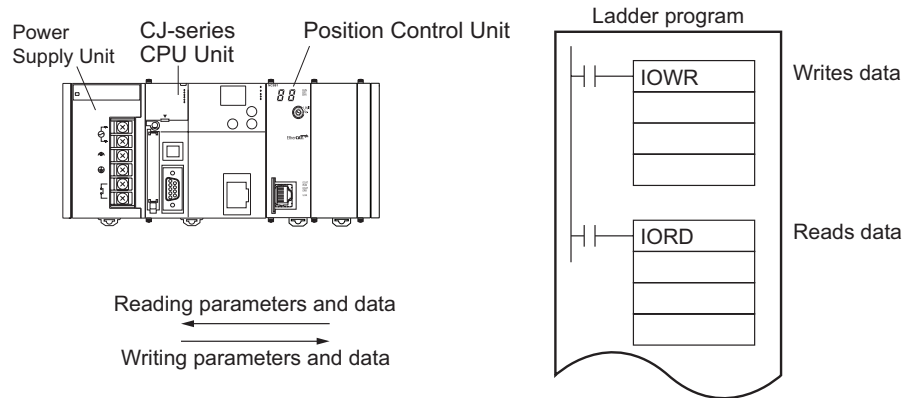

Transferring Data with the CX-Programmer

You can transfer data with the CX-Programmer to change all data.

You can download the parameters and the memory operation data that you created with the CX-Programmer to the PCU, and upload the internal data from the PCU.

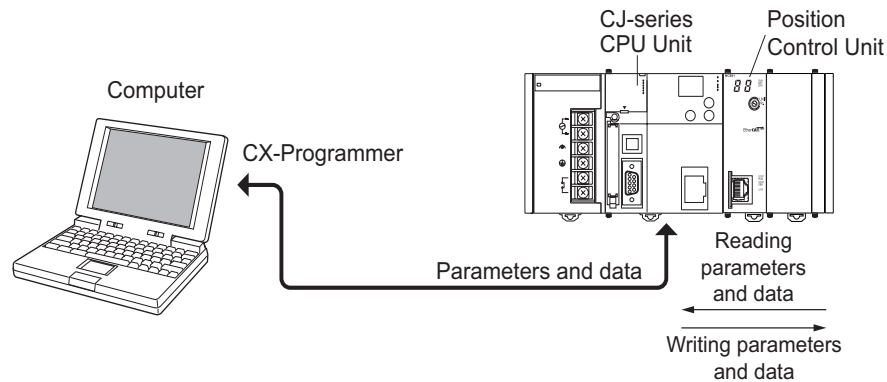

Saving Data

The transferred parameters or memory operation data is written to the internal memory of the PCU to operate, and will be lost if you turn OFF the power supply or restart the PCU.

You must save the data to a flash memory to save the transferred data in the PCU.

For details, refer to 9-7 *Saving Data* on page 9-56.

After you save the data to a flash memory, the data is used when you turn ON the power supply or restart the PCU.

If you only transferred the data, but did not save, the data is restored to the previously saved data when you turn OFF the power supply or restart the PCU.

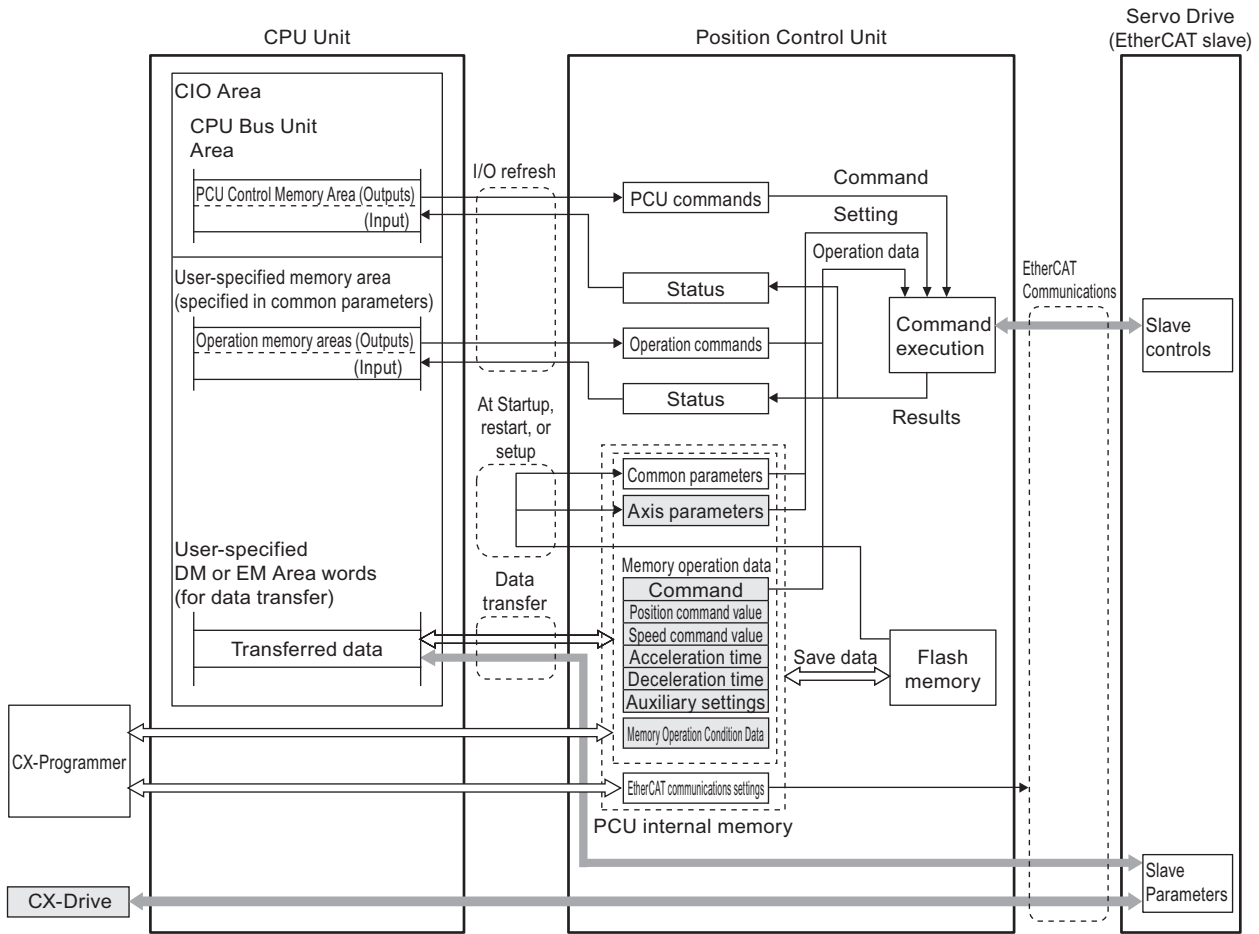

■ : The shaded areas are used when a G5-series Servo Drive is connected.

Precautions for Correct Use

Data that is set in the slave, such as the slave parameters, is not saved for the data save operation of the PCU.

Use the save operation for each slave to save the slave data.

Reference

The data that is saved is automatically read from flash memory and written to internal memory when the power supply to the PCU is turned ON, the PCU is restarted, or the PCU setup is completed.

Data Addresses

Each data item has an address within the PCU. When you transfer data, specify the address to distinguish the write destination or read source. Each address indicates 1 word (16 bits) of data.



Precautions for Correct Use

- ◆ When you transfer data, transfer the number of words required for each data item. For the data configuration, refer to *Section 6 Setting Data*.
- ◆ Transfer data using the parameter types given below. You cannot transfer data containing multiple parameters types at the same time.
- ◆ You cannot use the IOWR(223) instruction or the data transfer bits during a normal operation to write parameters that are enabled only when you turn ON the power supply, restart the PCU, or set up the PCU. You can write these parameters only through a data transfer from the CX-Programmer or by using the data transfer bits during PCU setup.

√: Transfer permitted, –: Transfer not permitted

Data name	Parameter type	Address range	Write Data Bit	Read Data Bit	IOWR (223) instruction	IORD (222) instruction	Transfer from the software
Common parameters	0100 hex	0001 to 0036 hex	√	√	√	–	√
Axis 1 parameters	0201 hex	0000 to 0081 hex	√	√	√	–	√
Axis 2 parameters	0202 hex	0000 to 0081 hex					
Axis 3 parameters	0203 hex	0000 to 0081 hex					
Axis 4 parameters	0204 hex	0000 to 0081 hex					
Axis 5 parameters	0205 hex	0000 to 0081 hex					
Axis 6 parameters	0206 hex	0000 to 0081 hex					
Axis 7 parameters	0207 hex	0000 to 0081 hex					
Axis 8 parameters	0208 hex	0000 to 0081 hex					
Axis 9 parameters	0209 hex	0000 to 0081 hex					
Axis 10 parameters	020A hex	0000 to 0081 hex					
Axis 11 parameters	020B hex	0000 to 0081 hex					
Axis 12 parameters	020C hex	0000 to 0081 hex					
Axis 13 parameters	020D hex	0000 to 0081 hex					
Axis 14 parameters	020E hex	0000 to 0081 hex					
Axis 15 parameters	020F hex	0000 to 0081 hex					
Axis 16 parameters	0210 hex	0000 to 0081 hex					

9-1 Outline of Data Transfer

Data name	Parameter type	Address range	Write Data Bit	Read Data Bit	IOWR (223) instruction	IORD (222) instruction	Transfer from the software
Task 1 memory operation parameters	0301 hex	0000 to 0005 hex	√	√	√	-	√
Task 2 memory operation parameters	0302 hex	0000 to 0005 hex					
Task 3 memory operation parameters	0303 hex	0000 to 0005 hex					
Task 4 memory operation parameters	0304 hex	0000 to 0005 hex					
Task 1 memory operation data	0401 hex	0000 to 61A7 hex	√	√	√	-	√
Task 2 memory operation data	0402 hex	0000 to 61A7 hex					
Task 3 memory operation data	0403 hex	0000 to 61A7 hex					
Task 4 memory operation data	0404 hex	0000 to 61A7 hex					
Memory operation condition data	0500 hex	0000 to 03E7 hex	√	√	√	-	√
Axis 1 feedback counter present value	1101 hex	-	-	-	-	√	-
Axis 2 feedback counter present value	1102 hex	-					
Axis 3 feedback counter present value	1103 hex	-					
Axis 4 feedback counter present value	1104 hex	-					
Axis 5 feedback counter present value	1105 hex	-					
Axis 6 feedback counter present value	1106 hex	-					
Axis 7 feedback counter present value	1107 hex	-					
Axis 8 feedback counter present value	1108 hex	-					
Axis 9 feedback counter present value	1109 hex	-				-	
Axis 10 feedback counter present value	110A hex	-					
Axis 11 feedback counter present value	110B hex	-					
Axis 12 feedback counter present value	110C hex	-					
Axis 13 feedback counter present value	110D hex	-					
Axis 14 feedback counter present value	110E hex	-					
Axis 15 feedback counter present value	110F hex	-					
Axis 16 feedback counter present value	1110 hex	-					



Data name	Parameter type	Address range	Write Data Bit	Read Data Bit	IOWR (223) instruction	IORD (222) instruction	Transfer from the software
Axis 1 present position latch data	1201 hex	—					
Axis 2 present position latch data	1202 hex	—					
Axis 3 present position latch data	1203 hex	—					
Axis 4 present position latch data	1204 hex	—					
Axis 5 present position latch data	1205 hex	—					
Axis 6 present position latch data	1206 hex	—					
Axis 7 present position latch data	1207 hex	—					
Axis 8 present position latch data	1208 hex	—				√	—
Axis 9 present position latch data	1209 hex	—	—	—	—		
Axis 10 present position latch data	120A hex	—					
Axis 11 present position latch data	120B hex	—					
Axis 12 present position latch data	120C hex	—					
Axis 13 present position latch data	120D hex	—					
Axis 14 present position latch data	120E hex	—					
Axis 15 present position latch data	120F hex	—					
Axis 16 present position latch data	1210 hex	—					
Axis 1 origin position latch data	1301 hex	—					
Axis 2 origin position latch data	1302 hex	—					
Axis 3 origin position latch data	1303 hex	—					
Axis 4 origin position latch data	1304 hex	—					
Axis 5 origin position latch data	1305 hex	—					
Axis 6 origin position latch data	1306 hex	—					
Axis 7 origin position latch data	1307 hex	—					
Axis 8 origin position latch data	1308 hex	—				√	—
Axis 9 origin position latch data	1309 hex	—	—	—	—		
Axis 10 origin position latch data	130A hex	—					
Axis 11 origin position latch data	130B hex	—					
Axis 12 origin position latch data	130C hex	—					
Axis 13 origin position latch data	130D hex	—					
Axis 14 origin position latch data	130E hex	—					
Axis 15 origin position latch data	130F hex	—					
Axis 16 origin position latch data	1310 hex	—					

9-1 Outline of Data Transfer

Data name	Parameter type	Address range	Write Data Bit	Read Data Bit	IOWR (223) instruction	IORD (222) instruction	Transfer from the software
Node address 1 slave parameters	3001 hex	—					
Node address 2 slave parameters	3002 hex	—					
Node address 3 slave parameters	3003 hex	—					
Node address 4 slave parameters	3004 hex	—					
Node address 5 slave parameters	3005 hex	—					
Node address 6 slave parameters	3006 hex	—					
Node address 7 slave parameters	3007 hex	—					
Node address 8 slave parameters	3008 hex	—					
Node address 9 slave parameters	3009 hex	—					
Node address 10 slave parameters	300A hex	—					
Node address 11 slave parameters	300B hex	—					
Node address 12 slave parameters	300C hex	—					
Node address 13 slave parameters	300D hex	—					
Node address 14 slave parameters	300E hex	—					
Node address 15 slave parameters	300F hex	—					
Node address 16 slave parameters	3010 hex	—					
Node address 17 slave parameters	3011 hex	—					
Node address 18 slave parameters	3012 hex	—					
Node address 19 slave parameters	3013 hex	—	√	√	√	—	*1
Node address 20 slave parameters	3014 hex	—					
Node address 21 slave parameters	3015 hex	—					
Node address 22 slave parameters	3016 hex	—					
Node address 23 slave parameters	3017 hex	—					
Node address 24 slave parameters	3018 hex	—					
Node address 25 slave parameters	3019 hex	—					
Node address 26 slave parameters	301A hex	—					
Node address 27 slave parameters	301B hex	—					
Node address 28 slave parameters	301C hex	—					
Node address 29 slave parameters	301D hex	—					
Node address 30 slave parameters	301E hex	—					
Node address 31 slave parameters	301F hex	—					
Node address 32 slave parameters	3020 hex	—					
Node address 33 slave parameters	3021 hex	—					
Node address 34 slave parameters	3022 hex	—					
Node address 35 slave parameters	3023 hex	—					
Node address 36 slave parameters	3024 hex	—					
Node address 37 slave parameters	3025 hex	—					

Data name	Parameter type	Address range	Write Data Bit	Read Data Bit	IOWR (223) instruction	IORD (222) instruction	Transfer from the software
Node address 38 slave parameters	3026 hex	—					
Node address 39 slave parameters	3027 hex	—					
Node address 40 slave parameters	3028 hex	—					
Node address 41 slave parameters	3029 hex	—					
Node address 42 slave parameters	302A hex	—					
Node address 43 slave parameters	302B hex	—					
Node address 44 slave parameters	302C hex	—					
Node address 45 slave parameters	302D hex	—					
Node address 46 slave parameters	302E hex	—					
Node address 47 slave parameters	302F hex	—					
Node address 48 slave parameters	3030 hex	—					
Node address 49 slave parameters	3031 hex	—					
Node address 50 slave parameters	3032 hex	—					
Node address 51 slave parameters	3033 hex	—					
Node address 52 slave parameters	3034 hex	—					
Node address 53 slave parameters	3035 hex	—					
Node address 54 slave parameters	3036 hex	—					
Node address 55 slave parameters	3037 hex	—					
Node address 56 slave parameters	3038 hex	—	√	√	√	—	*1
Node address 57 slave parameters	3039 hex	—					
Node address 58 slave parameters	303A hex	—					
Node address 59 slave parameters	303B hex	—					
Node address 60 slave parameters	303C hex	—					
Node address 61 slave parameters	303D hex	—					
Node address 62 slave parameters	303E hex	—					
Node address 63 slave parameters	303F hex	—					
Node address 64 slave parameters	3040 hex	—					
Node address 65 slave parameters	3041 hex	—					
Node address 66 slave parameters	3042 hex	—					
Node address 67 slave parameters	3043 hex	—					
Node address 68 slave parameters	3044 hex	—					
Node address 69 slave parameters	3045 hex	—					
Node address 70 slave parameters	3046 hex	—					
Node address 71 slave parameters	3047 hex	—					
Node address 72 slave parameters	3048 hex	—					
Node address 73 slave parameters	3049 hex	—					
Node address 74 slave parameters	304A hex	—					



9-1 Outline of Data Transfer

Data name	Parameter type	Address range	Write Data Bit	Read Data Bit	IOWR (223) instruction	IORD (222) instruction	Transfer from the software
Node address 75 slave parameters	304B hex	–	√	√	√	–	*1
Node address 76 slave parameters	304C hex	–					
Node address 77 slave parameters	304D hex	–					
Node address 78 slave parameters	304E hex	–					
Node address 79 slave parameters	304F hex	–					
Node address 80 slave parameters	3050 hex	–					
Axis 1 high-speed PTP start	8001 hex	–	–	–	√	–	
Axis 2 high-speed PTP start	8002 hex	–					
Axis 3 high-speed PTP start	8003 hex	–					
Axis 4 high-speed PTP start	8004 hex	–					
Axis 5 high-speed PTP start	8005 hex	–					
Axis 6 high-speed PTP start	8006 hex	–					
Axis 7 high-speed PTP start	8007 hex	–					
Axis 8 high-speed PTP start	8008 hex	–					
Axis 9 high-speed PTP start	8009 hex	–					
Axis 10 high-speed PTP start	800A hex	–					
Axis 11 high-speed PTP start	800B hex	–					
Axis 12 high-speed PTP start	800C hex	–					
Axis 13 high-speed PTP start	800D hex	–					
Axis 14 high-speed PTP start	800E hex	–					
Axis 15 high-speed PTP start	800F hex	–					
Axis 16 high-speed PTP start	8010 hex	–					

*1. Data can be transferred using the CX-Drive only for an OMNUC G5-series Servo Drive with EtherCAT or a SYSDRIVE MX2-series Servo Drive with an EtherCAT Communications Unit mounted.

Common Parameter Addresses

The unit addresses of the common parameters are given below.

Parameter Type

Data name	Parameter type
Common parameters	0100 hex

Unit Addresses

√ : Always enabled, – : Enabled at startup, PCU restart, or PCU setup

Parameter name	Unit address	Number of words	Update timing
Manual Operation Command Memory Area Selection	0001 hex	1	–
First Word of Manual Operation Command Memory Area	0002 hex	1	–
Direct Operation Command Memory Area Selection	0003 hex	1	–
First Word of Direct Operation Command Memory Area	0004 hex	1	–
Memory Operation Command Memory Area Selection	0005 hex	1	–
First Word in Memory Operation Command Memory Area	0006 hex	1	–
Axis Status Memory Area Selection	0007 hex	1	–
First Word in Axis Status Memory Area	0008 hex	1	–
Memory Operation Status Memory Area Selection	0009 hex	1	–
First Word in Memory Operation Status Memory Area	000A hex	1	–
Expanded Monitor Memory Area Selection	000B hex	1	–
First Word of Expanded Monitor Memory Area	000C hex	1	–
Absolute Encoder Rotation Axis Offset Automatic Save Setting	0013 hex	1	–
Synchronous Data Link Send Selection 1	0014 hex	1	–
Synchronous Data Link Send Selection 2	0015 hex	1	–
Synchronous Data Link Send Selection 3	0016 hex	1	–
Synchronous Data Link Send Selection 4	0017 hex	1	–
Synchronous Data Link Send Selection 5	0018 hex	1	–
Synchronous Data Link Send Selection 6	0019 hex	1	–
Synchronous Data Link Send Selection 7	001A hex	1	–
Synchronous Data Link Send Selection 8	001B hex	1	–
Synchronous Data Link Send Selection 9	001C hex	1	–
Synchronous Data Link Send Selection 10	001D hex	1	–
Synchronous Data Link Send Selection 11	001E hex	1	–
Synchronous Data Link Send Selection 12	001F hex	1	–
Synchronous Data Link Send Selection 13	0020 hex	1	–

9-1 Outline of Data Transfer

Parameter name	Unit address	Number of words	Update timing
Synchronous Data Link Send Selection 14	0021 hex	1	–
Synchronous Data Link Send Selection 15	0022 hex	1	–
Synchronous Data Link Send Selection 16	0023 hex	1	–
Synchronous Data Link Send Selection 17	0024 hex	1	–
Synchronous Data Link Send Selection 18	0025 hex	1	–
Synchronous Data Link Send Selection 19	0026 hex	1	–
Synchronous Data Link Send Selection 20	0027 hex	1	–
Synchronous Data Link Send Selection 21	0028 hex	1	–
Synchronous Data Link Send Selection 22	0029 hex	1	–
Synchronous Data Link Send Selection 23	002A hex	1	–
Synchronous Data Link Send Selection 24	002B hex	1	–
Synchronous Data Link Send Selection 25	002C hex	1	–
Synchronous Data Link Send Selection 26	002D hex	1	–
Synchronous Data Link Send Selection 27	002E hex	1	–
Synchronous Data Link Send Selection 28	002F hex	1	–
Synchronous Data Link Send Selection 29	0030 hex	1	–
Synchronous Data Link Send Selection 30	0031 hex	1	–
Synchronous Data Link Send Selection 31	0032 hex	1	–
Synchronous Data Link Send Selection 32	0033 hex	1	–
Absolute Encoder Origin Establishment Timing Setting	0034 hex	1	–
Input Data Clear Mode for Communications Error	0036 hex	1	–

Axis Parameter Addresses

There are axis parameters for each axis. The parameter type is different for each axis, but the unit address is the same.

Parameter Types

Data name	Parameter type
Axis 1 parameters	0201 hex
Axis 2 parameters	0202 hex
Axis 3 parameters	0203 hex
Axis 4 parameters	0204 hex
Axis 5 parameters	0205 hex
Axis 6 parameters	0206 hex
Axis 7 parameters	0207 hex
Axis 8 parameters	0208 hex
Axis 9 parameters	0209 hex
Axis 10 parameters	020A hex
Axis 11 parameters	020B hex
Axis 12 parameters	020C hex
Axis 13 parameters	020D hex
Axis 14 parameters	020E hex
Axis 15 parameters	020F hex
Axis 16 parameters	0210 hex

Unit Addresses

√ : Always enabled, – : Enabled at startup, PCU restart, or PCU setup

Parameter name	Unit address	Number of words	Update timing
Axis Type	0000 hex	1	–
I/O Function Selection*1	0002 hex	1	–
Limit Input Stop Method	0004 hex	1	–
Drive Alarm Reset Output Time	0007 hex	1	–
Positioning Monitoring Time	0008 hex	1	–
Maximum Speed	0009 hex	2	–
Starting Speed	000B hex	2	–
Operation at Reverse Rotation Command	000D hex	1	–
Acceleration/Deceleration Curve Selection	000E hex	1	–
Acceleration/Deceleration Time Selection	000F hex	1	–
Single Axis Deceleration Time at Interpolation	0010 hex	2	√
Max Torque	0016 hex	1	–
Output Direction	0017 hex	1	–
Axis Feeding Mode	0018 hex	1	–
Rotation Axis Upper Limit	0019 hex	2	–
Displayed Unit	001B hex	1	–
Command Pulses Count Per Motor Rotation	001C hex	2	–
Work Travel Distance Per Motor Rotation	001E hex	2	–
Unit Multiplier	0020 hex	1	–
Starting Present Position Clear Enable Selection	0025 hex	1	–
Software Limit Function Selection	0026 hex	1	√
Reverse Software Limit	0027 hex	4*2	√
Forward Software Limit			
Zone 0 Function Selection	002B hex	1	√
Zone 0 Lower Limit	002C hex	4*2	√
Zone 0 Upper Limit			
Zone 1 Function Selection	0030 hex	1	√
Zone 1 Lower Limit	0031 hex	4*2	√
Zone 1 Upper Limit			
Zone 2 Function Selection	0035 hex	1	√
Zone 2 Lower Limit	0036 hex	4*2	√
Zone 2 Upper Limit			
Interrupt Feeding Setting	003A hex	1	√
Interrupt Feeding Amount	003B hex	2	√
Origin Search Operation Mode	003D hex	1	√
Operation at Forward Limit Input	003E hex	1	√
Operation at Reverse Limit Input	003F hex	1	√
Origin Search Direction*3	0040 hex	1	√

Parameter name	Unit address	Number of words	Update timing
Origin Search Holding Time	0041 hex	1	√
Origin Input Mask Amount	0042 hex	2	√
Origin Compensation Value	0044 hex	2	√
Origin Position Offset	0046 hex	2	√
Origin Search Speed	0048 hex	4 ^{*2}	√
Origin Search Approach Speed			
Origin Search Compensation Speed	004C hex	2	√
Origin Search Acceleration Time	004E hex	2	√
Origin Search Deceleration Time	0050 hex	2	√
Origin Return Speed	0052 hex	2	√
Origin Return Acceleration Time	0054 hex	2	√
Origin Return Deceleration Time	0056 hex	2	√
Inching Width	0058 hex	1	√
Jogging/Inching Speed 1	0059 hex	2	√
Jogging/Inching Speed 2	005B hex	2	√
Jogging Acceleration Time	005D hex	2	√
Jogging Deceleration Time	005F hex	2	√
Encoder Type	0065 hex	1	—
Absolute Encoder Origin Position Offset	0066 hex	2	—
Expanded Monitor Type	0068 hex	1	√
Deviation Monitor Setting ^{*4}	0069 hex	1	√
Feedback Speed Sampling Cycle	006A hex	1	√
Speed Deviation Monitor Dwell Time	006B hex	1	√
Speed Deviation Limit Value	006C hex	1	√
Position Deviation Limit Value	006D hex	1	√
Synchronous Group Stop Selection	006E hex	1	—
Synchronous Feeding Position Function Selection	006F hex	1	√
Positioning Completed Width	0070 hex	2	√
Synchronous Feeding Velocity Function Selection	0072 hex	1	√
Synchronous Feeding Torque Option Selection	0073 hex	1	√
Synchronous Feeding Torque Function Selection	0074 hex	1	√
Synchronous Feeding Velocity Limitation Option	0075 hex	1	√
Expanded Monitor 2 Type	0078 hex	1	√
Expanded Monitor 3 Type	0079 hex	1	√
Expanded Monitor 4 Type	007A hex	1	√
Expanded Monitor 5 Type	007B hex	1	√
Expanded Monitor 6 Type	007C hex	1	√
Synchronous Feeding Auxiliary Axis Option	007D hex	1	√
Synchronous Feeding Position Master Axis Multiplier Numerator	007F hex	1	√

9-1 Outline of Data Transfer

Parameter name	Unit address	Number of words	Update timing
Synchronous Feeding Position Master Axis Multiplier Denominator	0080 hex	1	√
Synchronous Feeding Position Filter Constant	0081 hex	1	√

*1. Use the bits to set this parameter. The bit allocations are as follows:

Bit	Parameter name
00 to 09	Not used. Set 0.
10	Origin Proximity Input Signal Selection
11	Origin Input Signal Selection
12	Interrupt Input Function
13 to 15	Not used. Set 0.

*2. The Forward/Reverse Software Limits; the Zone 0, 1, and 2 Upper/lower Limits; and the Origin Search Speed and Origin Search Approach Speed are each handled as a set of data. If you want to transfer these data, transfer four words of data, as shown below. The words given below are relative to the unit addresses of respective data.

Data name	Words	Setting
Forward Software Limit Reverse Software Limit	+0	Reverse Software Limit (lower word)
	+1	Reverse Software Limit (upper word)
	+2	Forward Software Limit (lower word)
	+3	Forward Software Limit (upper word)
Zone 0, 1 and 2 Upper Limit, Lower Limit	+0	Zone Lower Limit (lower word)
	+1	Zone Lower Limit (upper word)
	+2	Zone Upper Limit (lower word)
	+3	Zone Upper Limit (upper word)
Origin Search Speed Origin Search Approach Speed	+0	Origin Search Speed (lower word)
	+1	Origin Search Speed (upper word)
	+2	Origin Search Approach Speed (lower word)
	+3	Origin Search Approach Speed (upper word)

*3. Use the bits to set this parameter. The bit allocations are as follows:

Bit	Parameter name
00	Origin Search Start Direction
01	Origin Input Detection Direction
02 to 15	Not used. Set 0.

*4. Use the bits to set this parameter. The bit allocations are as follows:

Bit	Parameter name
00	Speed Deviation Monitor Valid
01	Position Deviation Monitor Valid
02 to 15	Not used. Set 0.

Memory Operation Parameter Addresses

There are memory operation parameter for each task. The parameter type is different for each task, but the unit address is the same.

Parameter Types

Data name	Parameter type
Task 1 memory operation parameters	0301 hex
Task 2 memory operation parameters	0302 hex
Task 3 memory operation parameters	0303 hex
Task 4 memory operation parameters	0304 hex

Unit Address

√ : Always enabled, – : Enabled at startup, PCU restart, or PCU setup

Parameter name	Unit address	Number of words	Update timing
Configuration Axes	0000 hex	1	–
Teaching Target	0001 hex	1	√
Interpolation Axis Stop Method	0002 hex	1	–
Deviation between Axes Monitor Enable	0003 hex	1	√
Deviation between Axes Limit Value	0004 hex	1	√
Deviation between Axes Monitor Target Axis	0005 hex	1	√

Memory Operation Data Addresses

There is memory operation data for each task. The parameter type is different for each task. The memory operation data for one task consists of up to 500 sequence data. The address configuration for sequence data depends on the command. All memory operation data is always enabled.

Parameter Types

Data name	Parameter type	Address range
Task 1 memory operation data	0401 hex	0000 to 61A7 hex
Task 2 memory operation data	0402 hex	0000 to 61A7 hex
Task 3 memory operation data	0403 hex	0000 to 61A7 hex
Task 4 memory operation data	0404 hex	0000 to 61A7 hex

Sequence Data Configuration

Transfer 50 words for the sequence data for one sequence.

Sequence number	Unit addresses	
Sequence Data 1	0000 to 0031 hex	(0 to 49 words)
Sequence Data 2	0032 to 0063 hex	(50 to 99 words)
Sequence Data 3	0064 to 0095 hex	(100 to 149 words)
Sequence Data 4	0096 to 00C7 hex	(150 to 199 words)
Sequence Data 5	00C8 to 00F9 hex	(200 to 249 words)
:	:	:
Sequence Data 500	6176 to 61A7 hex	(24,950 to 24,999 words)

Unit Addresses

The unit addresses of the memory operation data depends on the command.
Specify the unit addresses carefully when you transfer memory operation data.

Unit address	Command		
	JUMP	FOR	NEXT
+0	Configuration axis 1 command position (lower word) ^{*1}	Configuration axis 1 command position (lower word) ^{*1}	Configuration axis 1 command position (lower word) ^{*1}
+1	Configuration axis 1 command position (upper word) ^{*1}	Configuration axis 1 command position (upper word) ^{*1}	Configuration axis 1 command position (upper word) ^{*1}
+2	Configuration axis 2 command position (lower word) ^{*1}	Configuration axis 2 command position (lower word) ^{*1}	Configuration axis 2 command position (lower word) ^{*1}
+3	Configuration axis 2 command position (upper word) ^{*1}	Configuration axis 2 command position (upper word) ^{*1}	Configuration axis 2 command position (upper word) ^{*1}
+4	Configuration axis 3 command position (lower word) ^{*1}	Configuration axis 3 command position (lower word) ^{*1}	Configuration axis 3 command position (lower word) ^{*1}
+5	Configuration axis 3 command position (upper word) ^{*1}	Configuration axis 3 command position (upper word) ^{*1}	Configuration axis 3 command position (upper word) ^{*1}
+6	Configuration axis 4 command position (lower word) ^{*1}	Configuration axis 4 command position (lower word) ^{*1}	Configuration axis 4 command position (lower word) ^{*1}
+7	Configuration axis 4 command position (upper word) ^{*1}	Configuration axis 4 command position (upper word) ^{*1}	Configuration axis 4 command position (upper word) ^{*1}
+8	Command	Command	Command
+9	Sequence start condition	Sequence start condition	Sequence start condition
+10	Jump/repeat condition	Jump/repeat condition	Repeat loop number
+11	Jump destination sequence number	Repeat loop number	Not used. ^{*2}
+12 to +49	Not used. ^{*2}	Not used. ^{*2}	

*1. You can set a command position for each command, although it is not necessary for all commands. The set value will be ignored if it is not necessary.

*2. Set 0000 hex for unused addresses.

Unit address	Command		
	PSET	PRSET	END
+0	Configuration axis 1 command position (lower word) ^{*1}	Configuration axis 1 command position (lower word) ^{*1}	Configuration axis 1 command position (lower word) ^{*1}
+1	Configuration axis 1 command position (upper word) ^{*1}	Configuration axis 1 command position (upper word) ^{*1}	Configuration axis 1 command position (upper word) ^{*1}
+2	Configuration axis 2 command position (lower word) ^{*1}	Configuration axis 2 command position (lower word) ^{*1}	Configuration axis 2 command position (lower word) ^{*1}
+3	Configuration axis 2 command position (upper word) ^{*1}	Configuration axis 2 command position (upper word) ^{*1}	Configuration axis 2 command position (upper word) ^{*1}
+4	Configuration axis 3 command position (lower word) ^{*1}	Configuration axis 3 command position (lower word) ^{*1}	Configuration axis 3 command position (lower word) ^{*1}
+5	Configuration axis 3 command position (upper word) ^{*1}	Configuration axis 3 command position (upper word) ^{*1}	Configuration axis 3 command position (upper word) ^{*1}
+6	Configuration axis 4 command position (lower word) ^{*1}	Configuration axis 4 command position (lower word) ^{*1}	Configuration axis 4 command position (lower word) ^{*1}
+7	Configuration axis 4 command position (upper word) ^{*1}	Configuration axis 4 command position (upper word) ^{*1}	Configuration axis 4 command position (upper word) ^{*1}
+8	Command	Command	Command
+9	Sequence start condition	Sequence start condition	Sequence start condition
+10	Output signals	Output signals	Not used. ^{*2}
+11 to +49	Not used. ^{*2}	Not used. ^{*2}	

*1. You can set a command position for each command, although it is not necessary for all commands. The set value will be ignored if it is not necessary.

*2. Set 0000 hex for unused addresses.

Unit address	Command		
	Positioning operation	Linear interpolation operation	Circular interpolation (clockwise/counter-clockwise)
+0	Configuration axis 1 command position (lower word)	Configuration axis 1 command position (lower word)	Configuration axis 1 command position (lower word)
+1	Configuration axis 1 command position (upper word)	Configuration axis 1 command position (upper word)	Configuration axis 1 command position (upper word)
+2	Configuration axis 2 command position (lower word)	Configuration axis 2 command position (lower word)	Configuration axis 2 command position (lower word)
+3	Configuration axis 2 command position (upper word)	Configuration axis 2 command position (upper word)	Configuration axis 2 command position (upper word)
+4	Configuration axis 3 command position (lower word)	Configuration axis 3 command position (lower word)	Configuration axis 3 command position (lower word)
+5	Configuration axis 3 command position (upper word)	Configuration axis 3 command position (upper word)	Configuration axis 3 command position (upper word)
+6	Configuration axis 4 command position (lower word)	Configuration axis 4 command position (lower word)	Configuration axis 4 command position (lower word)
+7	Configuration axis 4 command position (upper word)	Configuration axis 4 command position (upper word)	Configuration axis 4 command position (upper word)
+8	Command	Command	Command

9-1 Outline of Data Transfer

Unit address	Command		
	Positioning operation	Linear interpolation operation	Circular interpolation (clockwise/counterclockwise)
+9	Sequence start condition	Sequence start condition	Sequence start condition
+10	Sequence skip condition	Sequence skip condition	Sequence skip condition
+11	End pattern	End pattern	End pattern
+12	Positioning completed input monitor valid	Positioning completed input monitor valid	Positioning completed input monitor valid
+13	Dwell timer	Dwell timer	Dwell timer
+14	M code	M code	M code
+15	Axis specification	Axis specification	Axis specification
+16	Position specification	Position specification	Position specification
+17	Configuration axis 1 rotation axis direction	Not used.*1	Not used.*1
+18	Configuration axis 1 command speed (lower word)	Interpolation speed (lower word)	Interpolation speed (lower word)
+19	Configuration axis 1 command speed (upper word)	Interpolation speed (upper word)	Interpolation speed (upper word)
+20	Configuration axis 1 acceleration time (lower word)	Interpolation acceleration time (lower word)	Interpolation acceleration time (lower word)
+21	Configuration axis 1 acceleration time (upper word)	Interpolation acceleration time (upper word)	Interpolation acceleration time (upper word)
+22	Configuration axis 1 deceleration time (lower word)	Interpolation deceleration time (lower word)	Interpolation deceleration time (lower word)
+23	Configuration axis 1 deceleration time (upper word)	Interpolation deceleration time (upper word)	Interpolation deceleration time (upper word)
+24	Configuration axis 2 rotation axis direction	Interpolation starting speed (lower word)	Interpolation starting speed (lower word)
+25	Configuration axis 2 command speed (lower word)	Interpolation starting speed (upper word)	Interpolation starting speed (upper word)
+26	Configuration axis 2 command speed (upper word)	Interpolation acceleration/ deceleration curve selection	Interpolation acceleration/ deceleration curve selection
+27	Configuration axis 2 acceleration time (lower word)	Interpolation acceleration/ deceleration time selection	Interpolation acceleration/ deceleration time selection
+28	Configuration axis 2 acceleration time (upper word)	Interpolation speed specification method	Configuration axis 1 circular center/passing point position (lower word)

Unit address	Command		
	Positioning operation	Linear interpolation operation	Circular interpolation (clockwise/counterclockwise)
+29	Configuration axis 2 deceleration time (lower word)	Not used.*1	Configuration axis 1 circular center/passing point position (upper word)
+30	Configuration axis 2 deceleration time (upper word)		Configuration axis 2 circular center/passing point position (lower word)
+31	Configuration axis 3 rotation axis direction		Configuration axis 2 circular center/passing point position (upper word)
+32	Configuration axis 3 command speed (lower word)		Configuration axis 3 circular center/passing point position (lower word)
+33	Configuration axis 3 command speed (upper word)		Configuration axis 3 circular center/passing point position (upper word)
+34	Configuration axis 3 acceleration time (lower word)		Configuration axis 4 circular center/passing point position (lower word)
+35	Configuration axis 3 acceleration time (upper word)		Configuration axis 4 circular center/passing point position (upper word)
+36	Configuration axis 3 deceleration time (lower word)		Circular radius (lower word)
+37	Configuration axis 3 deceleration time (upper word)		Circular radius (upper word)
+38	Configuration axis 4 rotation axis direction		Circular interpolation method
+39	Configuration axis 4 command speed (lower word)		Not used.*1
+40	Configuration axis 4 command speed (upper word)		
+41	Configuration axis 4 acceleration time (lower word)		
+42	Configuration axis 4 acceleration time (upper word)		
+43	Configuration axis 4 deceleration time (lower word)		
+44	Configuration axis 4 deceleration time (upper word)		
+45 to +49	Not used.*1		

*1. Set 0000 hex for unused addresses.



Unit address	Command		
	Speed control	Interrupt feeding for positioning	Interrupt feeding for speed control
+0	Configuration axis 1 command position (lower word) ^{*1}	Configuration axis 1 command position (lower word)	Configuration axis 1 command position (lower word) ^{*1}
+1	Configuration axis 1 command position (upper word) ^{*1}	Configuration axis 1 command position (upper word)	Configuration axis 1 command position (upper word) ^{*1}
+2	Configuration axis 2 command position (lower word) ^{*1}	Configuration axis 2 command position (lower word)	Configuration axis 2 command position (lower word) ^{*1}
+3	Configuration axis 2 command position (upper word) ^{*1}	Configuration axis 2 command position (upper word)	Configuration axis 2 command position (upper word) ^{*1}
+4	Configuration axis 3 command position (lower word) ^{*1}	Configuration axis 3 command position (lower word)	Configuration axis 3 command position (lower word) ^{*1}
+5	Configuration axis 3 command position (upper word) ^{*1}	Configuration axis 3 command position (upper word)	Configuration axis 3 command position (upper word) ^{*1}
+6	Configuration axis 4 command position (lower word) ^{*1}	Configuration axis 4 command position (lower word)	Configuration axis 4 command position (lower word) ^{*1}
+7	Configuration axis 4 command position (upper word) ^{*1}	Configuration axis 4 command position (upper word)	Configuration axis 4 command position (upper word) ^{*1}
+8	Command	Command	Command
+9	Sequence start condition	Sequence start condition	Sequence start condition
+10	Sequence skip condition	Sequence skip condition	Sequence skip condition
+11	End pattern	End pattern	End pattern
+12	Positioning completed input monitor valid	Positioning completed input monitor valid	Positioning completed input monitor valid
+13	Dwell timer	Dwell timer	Dwell timer
+14	M code	M code	M code
+15	Axis specification	Axis specification	Axis specification
+16	Not used. ^{*2}	Position specification	Not used. ^{*2}
+17		Rotation axis direction	
+18	Command speed (lower word)	Command speed (lower word)	Command speed (lower word)
+19	Command speed (upper word)	Command speed (upper word)	Command speed (upper word)
+20	Acceleration time (lower word)	Acceleration time (lower word)	Acceleration time (lower word)
+21	Acceleration time (upper word)	Acceleration time (upper word)	Acceleration time (upper word)
+22	Deceleration time (lower word)	Deceleration time (lower word)	Deceleration time (lower word)
+23	Deceleration time (upper word)	Deceleration time (upper word)	Deceleration time (upper word)

Unit address	Command		
	Speed control	Interrupt feeding for positioning	Interrupt feeding for speed control
+24	Not used.*2	Not used (0 bit)/ Error enable for undetected interrupt input (1 bit)	Not used.*2
+25		Interrupt feeding amount (lower word)	Interrupt feeding amount (lower word)
+26		Interrupt feeding amount (upper word)	Interrupt feeding amount (upper word)
+27 to +49		Not used.*2	Not used.*2

*1. You can set a command position for each command, although it is not necessary for all commands. The set value will be ignored if it is not necessary.

*2. Set 0000 hex for unused addresses.

Memory Operation Condition Data Addresses

The memory operation condition data is shared by all tasks.
All memory operation condition data are always enabled.

Parameter Type

Data name	Parameter type
Memory operation condition data	0500 hex

Memory Operation Condition Data Configuration

Condition data	Unit address
Condition Data 1	0000 to 0009 hex (words 0 to 9)
Condition Data 2	000A to 0013 hex (words 10 to 19)
Condition Data 3	0014 to 001D hex (words 20 to 29)
Condition Data 4	001E to 0027 hex (words 30 to 39)
Condition Data 5	0028 to 0031 hex (words 40 to 49)
:	:
Condition Data 100	03DE to 03E7 hex (words 990 to 999)

Unit Addresses

Unit address	Condition data name
+0	Condition
+1	Edge selection
+2	Data 1 area selection
+3	Data 1 word offset
+4	Data 1 bit
+5	Data 2 area selection
+6	Data 2 word offset
+7	Data 2 bit
+8	Timer/counter/constant data (lower word)
+9	Timer/counter/constant data (upper word)

Other Addresses

In addition, there are four data as described below.

Feedback Present Position

The feedback present position can be read using the IORD instruction.
(This data is read-only.)

Data name	Parameter type	Number of words
Axis 1 feedback counter present value	1101 hex	2
Axis 2 feedback counter present value	1102 hex	2
Axis 3 feedback counter present value	1103 hex	2
Axis 4 feedback counter present value	1104 hex	2
Axis 5 feedback counter present value	1105 hex	2
Axis 6 feedback counter present value	1106 hex	2
Axis 7 feedback counter present value	1107 hex	2
Axis 8 feedback counter present value	1108 hex	2
Axis 9 feedback counter present value	1109 hex	2
Axis 10 feedback counter present value	110A hex	2
Axis 11 feedback counter present value	110B hex	2
Axis 12 feedback counter present value	110C hex	2
Axis 13 feedback counter present value	110D hex	2
Axis 14 feedback counter present value	110E hex	2
Axis 15 feedback counter present value	110F hex	2
Axis 16 feedback counter present value	1110 hex	2

Present Position Latch Data

This is the area that is written when you use the present position latch function to load the present value to the PCU.

This data is read only. Use the IORD(222) instruction.

Data name	Parameter type	Number of words
Axis 1 present position latch data	1201 hex	2
Axis 2 present position latch data	1202 hex	2
Axis 3 present position latch data	1203 hex	2
Axis 4 present position latch data	1204 hex	2
Axis 5 present position latch data	1205 hex	2
Axis 6 present position latch data	1206 hex	2
Axis 7 present position latch data	1207 hex	2
Axis 8 present position latch data	1208 hex	2
Axis 9 present position latch data	1209 hex	2

Data name	Parameter type	Number of words
Axis 10 present position latch data	120A hex	2
Axis 11 present position latch data	120B hex	2
Axis 12 present position latch data	120C hex	2
Axis 13 present position latch data	120D hex	2
Axis 14 present position latch data	120E hex	2
Axis 15 present position latch data	120F hex	2
Axis 16 present position latch data	1210 hex	2

Origin Position Latch Data

This is the area that is written when you use the origin position latch function to load the present value to the PCU.

This data is read only. Use the IORD(222) instruction.

Data name	Parameter type	Number of words
Axis 1 origin position latch data	1301 hex	2
Axis 2 origin position latch data	1302 hex	2
Axis 3 origin position latch data	1303 hex	2
Axis 4 origin position latch data	1304 hex	2
Axis 5 origin position latch data	1305 hex	2
Axis 6 origin position latch data	1306 hex	2
Axis 7 origin position latch data	1307 hex	2
Axis 8 origin position latch data	1308 hex	2
Axis 9 origin position latch data	1309 hex	2
Axis 10 origin position latch data	130A hex	2
Axis 11 origin position latch data	130B hex	2
Axis 12 origin position latch data	130C hex	2
Axis 13 origin position latch data	130D hex	2
Axis 14 origin position latch data	130E hex	2
Axis 15 origin position latch data	130F hex	2
Axis 16 origin position latch data	1310 hex	2

Slave Parameters

Servo Drive and other slave parameters can be read or written as data or with the IOWR(223) instruction.

Data name	Parameter type	Number of words
Node address 1 slave parameters	3001 hex	*1
Node address 2 slave parameters	3002 hex	
Node address 3 slave parameters	3003 hex	
Node address 4 slave parameters	3004 hex	
Node address 5 slave parameters	3005 hex	
Node address 6 slave parameters	3006 hex	
Node address 7 slave parameters	3007 hex	
Node address 8 slave parameters	3008 hex	
Node address 9 slave parameters	3009 hex	
Node address 10 slave parameters	300A hex	
Node address 11 slave parameters	300B hex	
Node address 12 slave parameters	300C hex	
Node address 13 slave parameters	300D hex	
Node address 14 slave parameters	300E hex	
Node address 15 slave parameters	300F hex	
Node address 16 slave parameters	3010 hex	
Node address 17 slave parameters	3011 hex	
Node address 18 slave parameters	3012 hex	
Node address 19 slave parameters	3013 hex	
Node address 20 slave parameters	3014 hex	
Node address 21 slave parameters	3015 hex	
Node address 22 slave parameters	3016 hex	
Node address 23 slave parameters	3017 hex	
Node address 24 slave parameters	3018 hex	
Node address 25 slave parameters	3019 hex	
Node address 26 slave parameters	301A hex	
Node address 27 slave parameters	301B hex	
Node address 28 slave parameters	301C hex	
Node address 29 slave parameters	301D hex	
Node address 30 slave parameters	301E hex	
Node address 31 slave parameters	301F hex	
Node address 32 slave parameters	3020 hex	
Node address 33 slave parameters	3021 hex	
Node address 34 slave parameters	3022 hex	
Node address 35 slave parameters	3023 hex	
Node address 36 slave parameters	3024 hex	
Node address 37 slave parameters	3025 hex	

9-1 Outline of Data Transfer

Data name	Parameter type	Number of words
Node address 38 slave parameters	3026 hex	*1
Node address 39 slave parameters	3027 hex	
Node address 40 slave parameters	3028 hex	
Node address 41 slave parameters	3029 hex	
Node address 42 slave parameters	302A hex	
Node address 43 slave parameters	302B hex	
Node address 44 slave parameters	302C hex	
Node address 45 slave parameters	302D hex	
Node address 46 slave parameters	302E hex	
Node address 47 slave parameters	302F hex	
Node address 48 slave parameters	3030 hex	
Node address 49 slave parameters	3031 hex	
Node address 50 slave parameters	3032 hex	
Node address 51 slave parameters	3033 hex	
Node address 52 slave parameters	3034 hex	
Node address 53 slave parameters	3035 hex	
Node address 54 slave parameters	3036 hex	
Node address 55 slave parameters	3037 hex	
Node address 56 slave parameters	3038 hex	
Node address 57 slave parameters	3039 hex	
Node address 58 slave parameters	303A hex	
Node address 59 slave parameters	303B hex	
Node address 60 slave parameters	303C hex	
Node address 61 slave parameters	303D hex	
Node address 62 slave parameters	303E hex	
Node address 63 slave parameters	303F hex	
Node address 64 slave parameters	3040 hex	
Node address 65 slave parameters	3041 hex	
Node address 66 slave parameters	3042 hex	
Node address 67 slave parameters	3043 hex	
Node address 68 slave parameters	3044 hex	
Node address 69 slave parameters	3045 hex	
Node address 70 slave parameters	3046 hex	
Node address 71 slave parameters	3047 hex	
Node address 72 slave parameters	3048 hex	
Node address 73 slave parameters	3049 hex	
Node address 74 slave parameters	304A hex	
Node address 75 slave parameters	304B hex	
Node address 76 slave parameters	304C hex	
Node address 77 slave parameters	304D hex	

Data name	Parameter type	Number of words
Node address 78 slave parameters	304E hex	*1
Node address 79 slave parameters	304F hex	
Node address 80 slave parameters	3050 hex	

*1. For the number of words to transfer for slave parameters, specify the data size of the slave parameters in bytes.
Refer to the user's manual for your slave for the data size of the slave parameters.

Data Checks

The data checking method depends on the transfer method. Furthermore, an error may occur depending on the transfer method if you transfer data that contains data for more than one sequence.

Checks When You Transfer Data with Data Transfer Bits

When you write data with a data transfer bit, the data is first received in the receive buffer. If the received data is within the normal ranges, all data is written to the axis parameters or the memory operation data.

If even one data item is in an incorrect range, a warning is output and all received data is discarded.

The data is not checked when it is written during PCU setup. Check the consistency of all data when you save the data.

Furthermore, although you can write all data during PCU setup, you can write only the data that are continuously updated during a normal operation. For details, refer to *Operating Modes and Data Transfer* on page 9-30.

When you use the data transfer bits, you can transfer data that contains data for more than one sequence.

Checks When You Transfer Data with IOWR(223) Instructions

When you write data with the IOWR(223) instruction, the data is written not to the receive buffer, but directly to the axis parameters, the memory operation data, etc.

If even one data item is in an incorrect range, a warning is output and all received data is discarded.

When you transfer memory operation data with the IOWR(223) instruction, you cannot transfer data that contains data for more than one sequence. Always transfer data for only one sequence with each IOWR(223) instruction. A warning will occur if data for more than one sequence is transferred.

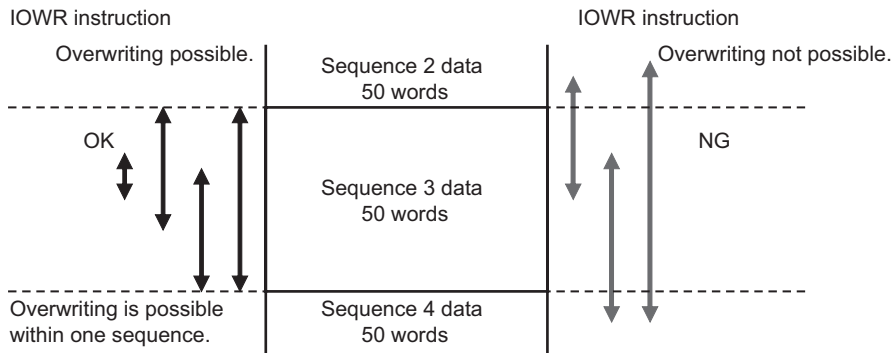

Precautions for Correct Use

- ◆ If a warning occurs as a result of a data check, turn ON the Warning Reset Bit once, and transfer the normal data again.
- ◆ Do not execute any command, such as data save or start, until the normal data is transferred. Doing so may result in an unexpected operation because data has not been transferred since the warning occurred.

Operating Modes and Data Transfer

The PCU has the following operating modes. The operations you can perform depend on the current operating mode.

The following table shows the relationship between the operating modes of the PCU and the data transfer and transfer method.

√: Permitted, -: Not permitted

Operating mode	Description of operating status	Transfer means		
		Data transfer bits	IOWR(223)/ IORD(222)	CX-Programmer
Initializing Mode	The PCU is in Initializing Mode from when you turn ON the power supply or execute a restart until the PCU starts. In this mode, the PCU Ready Flag (word n+11, bit 15) is OFF.	-	-	-
PCU Setup Mode	In this mode, the PCU Setup Flag (word n, bit 15) is ON and the PCU Ready Flag is OFF.	√	-	-
Support Software-controlled Data Transfer Mode	Support Software-controlled Data Transfer Mode is entered in response to a command from the CX-Programmer. In this mode, data can be transferred to and from the CX-Programmer. Ladder program outputs are disabled.	-	-	√
Support Software-controlled Operation Mode	Support Software-controlled Data Transfer Mode is entered in response to a command from the CX-Programmer. In this mode, operation from the CX-Programmer is possible. Ladder program outputs are disabled.	-	-	-
Normal Operation Mode	In Normal Operation Mode, the PCU Ready Flag is ON. Only data that is always updated regardless of the writing method can be written. Any data can be read.	√ (Constant data only)*1	√ (Constant data only)*1	√ (Constant data only)*1

*1. "Constant data only" refers to the parameter data, memory operation data, and memory operation condition data that is constantly updated.

9-2 Writing with the Data Transfer Bits

This section provides the procedure and a programming example for writing data to the PCU by using the Write Data Bit (word n, bit 12) in the PCU Control Memory Area.



Precautions for Correct Use

- ◆ Do not turn OFF the power supply or restart the PCU while data is being written. The PCU may not operate properly if all of the data is not transferred. If all of the data is not transferred, transfer it again.

Writing Procedure

This section describes the procedure for writing data to the PCU. Writing the operation data for task 1 is used as an example.

The CPU Bus Unit Area is used to write data with one of the data transfer bits.

You can calculate the first word in the CPU Bus Unit Area using the following formula:

First word allocated to PCU in CPU Bus Unit Area, $n = \text{CIO } 1500 + 25 \times \text{unit number}$

The words and bits that are necessary for transfer are listed in the following table.

PCU Control Output Memory Area

Words	Name	Bits	Bit name	Function
n	PCU Control Command Bits	12	Write Data Bit	Turn ON this bit to start writing data.
		14	Save Data Bit	Turn ON this bit to start saving data.
		15	PCU Setup Bit	Turn ON this bit to reset the PCU. The reset status is held as long as this bit remains ON.
n+1	Number of Data Transfer Words	0 to 15	–	Set the number of words to read or write. When transferring slave parameters, specify the data size of the slave parameters in bytes.

Words	Name	Bits	Bit name	Function
n+2	CPU Unit Data Transfer Area	0 to 15	–	Set the area in the CPU Unit. 00B0 (hex): Core I/O Area (CIO Area) 00B1 (hex): Work Area (WR Area) 00B2 (hex): Holding Area (HR) 0082 (hex): DM Area (DM) 0050 to 0068 (hex): EM Area (EM) ^{*1} 0050 (hex): EM bank 0 0051 (hex): EM bank 1 : 0068 (hex): EM bank 24 00A0 to 00AF (hex): EM Area (EM) ^{*2} 00A0 (hex): EM bank 0 00A1 (hex): EM bank 1 : 00AF (hex): EM bank F
n+3	CPU Unit Data Transfer Beginning Word	0 to 15	–	Set the beginning word in the CPU Unit. Specify the first word in the I/O memory of the CPU Unit that contains the data to transfer. This word will be in the data transfer area that was set. Example: To specify D00100 CPU Unit Data Transfer Area (n+2): 0082 (hex) CPU Unit Data Transfer Beginning Word (n+3): 0064 (hex)
n+4	PCU Data Transfer Area	0 to 15	–	Set the area in the PCU. Set the value in hexadecimal.
n+5	PCU Data Transfer Beginning Word ^{*3}	0 to 15	–	Set the address of beginning word 1 in the PCU. Set the value in hexadecimal.
n+6	PCU Data Transfer Beginning Word 2 ^{*4}	0 to 15	–	Set the address of beginning word 2 in the PCU. Set the value in hexadecimal.

- *1. CJ2 CPU Units. The number of banks that can be used depends on the model of the CPU Unit.
- *2. CJ1 CPU Units. The number of banks that can be used depends on the model of the CPU Unit.
- *3. If the Servo Drive Parameter Area is selected for the PCU Area, the setting of this parameter functions as an index.
- *4. If the Servo Drive Parameter Area is selected for the PCU Area, the setting of this parameter functions as a subindex.

PCU Control Input Memory Area

Words	Name	Bit	Bit name	Function
n+11	PCU Control Command Acknowledged Flags	12	Write Data Acknowledged Flag	This flag turns ON to acknowledge the Write Data Bit.
		14	Save Data Acknowledged Flag	This flag turns ON to acknowledge the Save Data Bit.
		15	PCU Ready Flag	This flag turns ON when the PCU is ready.

Words	Name	Bit	Bit name	Function
n+12	PCU Control Status	0	Data Transfer Flag	This flag remains ON while the data transfer is in progress.
		1	Data Transfer Invalid Flag	This flag turns ON when the data transfer fails.
		2	Data Transfer Completed Flag	This flag turns ON when a data write, data read, or data save operation is completed successfully.
		3	Save Data Request Flag	This flag turns ON whenever data will be lost if you turn OFF the power supply without saving the data.

Procedure

1. Specify the data in words n+1 to n+6.

Specify the Number of Data Transfer Words (word n+1), CPU Unit Data Transfer Area (word n+2), CPU Unit Data Transfer Beginning Word (word n+3), PCU Data Transfer Area (word n+4), PCU Data Transfer Area Beginning Word (word n+5), and PCU Data Transfer Area Beginning Word 2 (word n+6).

2. Turn ON the Write Data Bit (word n, bit 12) to write the data to the PCU.

If you turn ON the PCU Setup Bit (word n, bit 15) before the Write Data Bit, the operation of the PCU will stop and you can write all of the data.

If the PCU Setup Bit is OFF, you can write only data that is continuously updated.

3. Turn ON the Save Data Bit (word n, bit 14) to save the data that you wrote in the PCU.

This operation is not necessary if you do not want to save the data that was written.

Timing Chart

The following chart shows the timing for writing data.

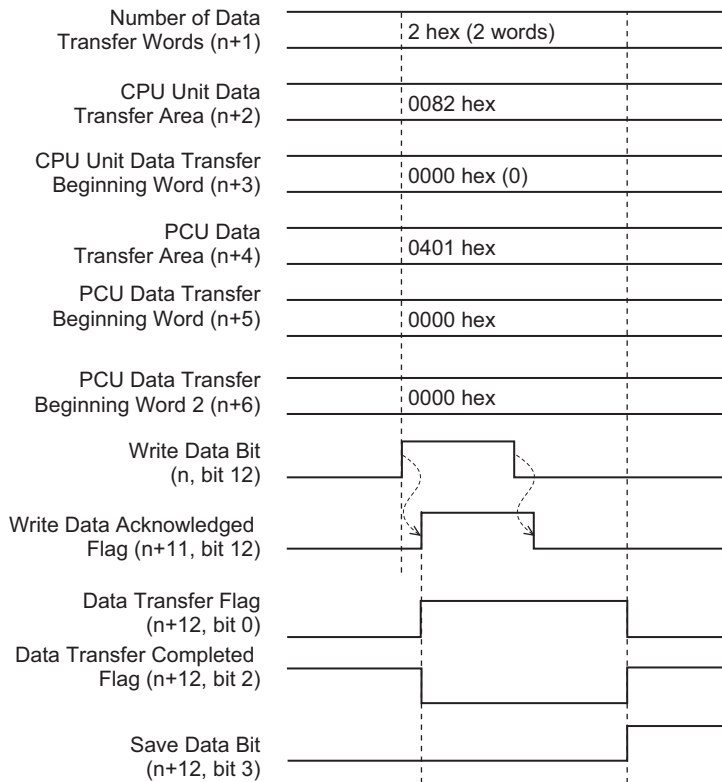

When data writing is completed, the Data Transfer Completed Flag (word n+12, bit 2) will turn ON. If an error occurs when data is written, the Data Transfer Invalid Flag (word n+12, bit 1) will turn ON and the error code will be output to word n+14.

Programming Example 1

This section provides a programming example that writes the following position data to the PCU. The PCU is set to unit number 3.

Data to be Transferred

The data to be written is the configuration axis 1 command position of sequence 1, and the configuration axis 2 command position of sequence 2.

The transfer source data is set as follows starting from D00000.

Task number	Parameter type	Sequence number	Transfer destination name	Transfer destination address	Transfer source area	Contents of setting
1	0401 hex	1	Configuration axis 1 command position (lower word)	0000 hex	D00000	157C hex
			Configuration axis 1 command position (upper word)	0001 hex	D00001	0000 hex (5500)
		2	Configuration axis 2 command position (lower word)	0034 hex	D00002	1F40 hex
			Configuration axis 2 command position (upper word)	0035 hex	D00003	0000 hex (8000)



Reference

The PCU Data Transfer Beginning Word 2 parameter is not used in this data transfer programming example.

Ladder Programming Example

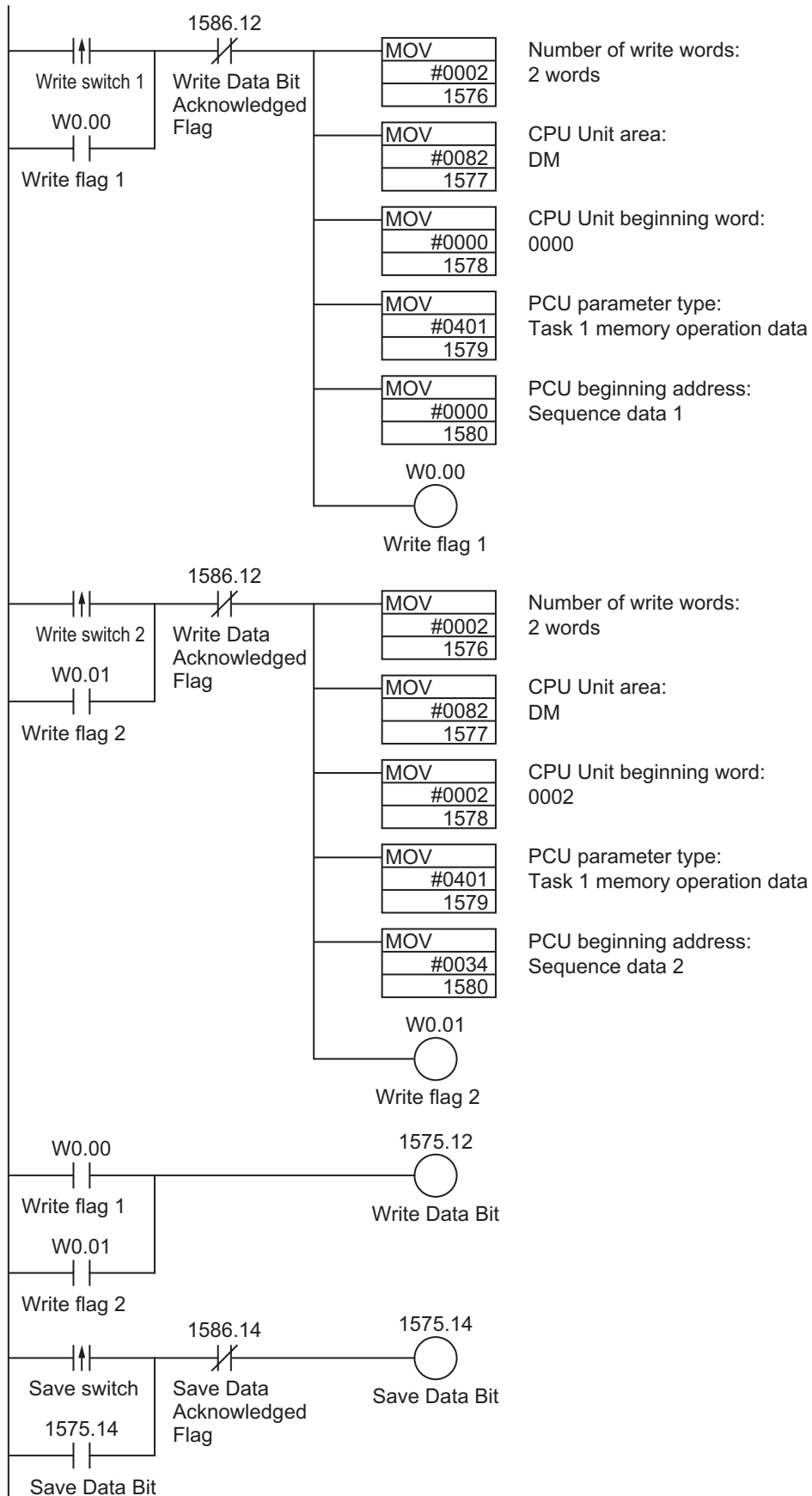

Programming Example 2

This programming example writes the slave parameters (Servo Drive objects) for an OMRON G5-series Servo Drive. The PCU is set to unit number 3.

Data to be Transferred

The data to be written is the forward external torque limit (index: 3525 hex, sub-index: none (0)) of the G5-series Servo Drive at node address 2 (axis 2).



Reference

Saving data to a OMNUC G5-series Servo Drive requires access to the store parameters (index: 1010 hex, sub-index: one (1)).

For details refer to the *OMNUC G5-series AC Servomotors/Servo Drives with Built-in EtherCAT Communications User's Manual* (Cat. No. I573).

1010 hex		Store Parameters						All	
Sub-index 0		Number of entries							
Setting range	–	Unit	–	Default	01 hex	Data attribute	–		
Size	1 byte (U8)		Access	RO	PDO mapping	Not possible			
Sub-index 1		Save all parameters							
Setting range	–	Unit	–	Default	00000001 hex	Data attribute	A		
Size	4 bytes (U32)		Access	RW	PDO mapping	Not possible			

- ♦ All storable parameters are saved into the Servo Drive's EEPROM.
- ♦ To prevent erroneous saving, these parameters are saved only when the a specific value is written to sub-index 1.
- ♦ The specific value is "save."

MSB		LSB	
e	v	a	s
65 hex	76 hex	61 hex	73 hex

3525 hex		Forward External Torque Limit						CSP CSV	
Setting range	0 to 5000	Unit	0.1%	Default	5000*1	Data attribute	B		
Size	2 bytes (INT16)		Access	RW	PDO mapping	Not possible			

*1. Limited by the maximum torque of the connected motor.

- ♦ The forward external torque limit is set for the torque limit switching input.

The transfer source data is set as follows starting from D00000.

Node address (axis number)	Parameter type	Transfer destination name	Object name	Destination address 1 (index)
2	3002 hex	Node address 2 slave parameters	Forward External Torque Limit	3525 hex

Destination address 2 (sub-index)	Number of words to transfer	Transfer source area	Contents of setting
0	2 (bytes)	D00000	01F4 hex (50.0%)

Ladder Programming Example

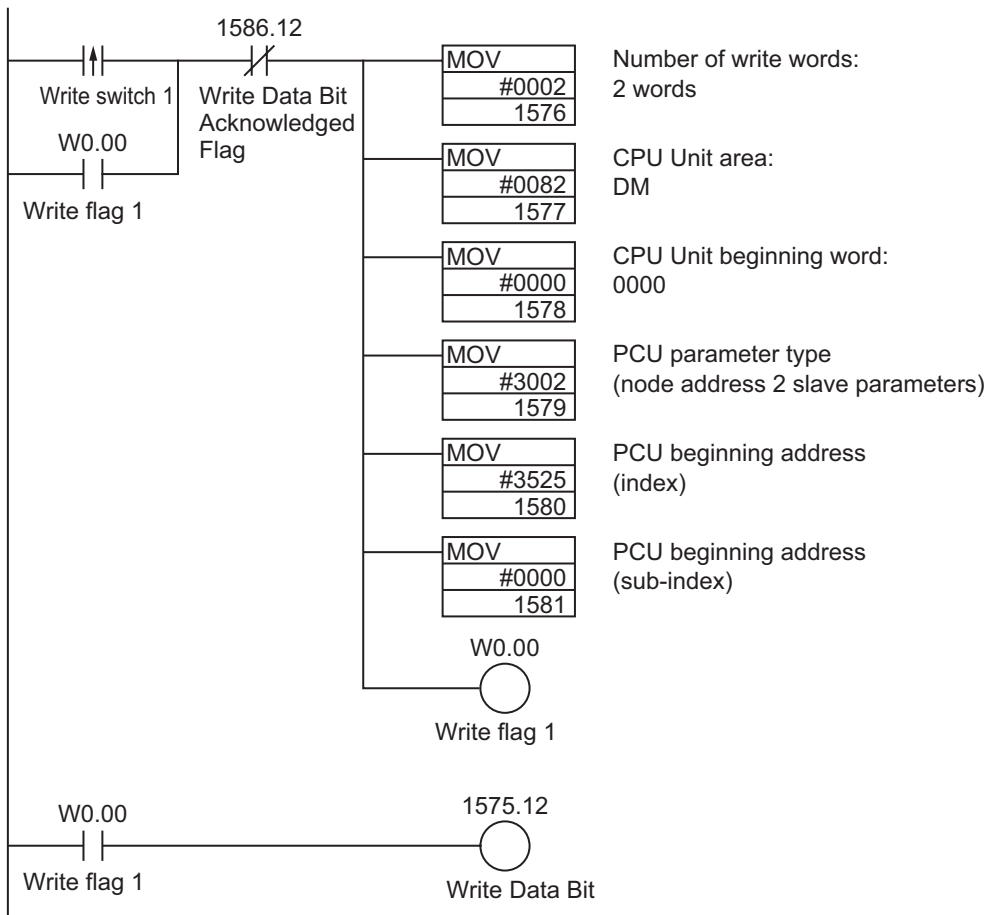

9-3 Reading with Data Transfer Bits

This section provides the procedure and a programming example for reading data from the PCU by using the Read Data Bit (word n, bit 13) in the PCU Control Memory Area.



Precautions for Correct Use

- ◆ When you read data, transfer the number of words required for each data item. Do not start or end in the middle of a data item.

Reading Procedure

This section describes the procedure for reading data from the PCU. Reading the operation data for task 1 is used as an example.

The CPU Bus Unit Area is used to read data with one of the data transfer bits.

You can calculate the first word in the CPU Bus Unit Area using the following formula:

First word allocated to PCU in CPU Bus Unit Area, $n = \text{CIO } 1500 + 25 \times \text{unit number}$

The words and bits that are necessary for transfer are listed in the following table.

PCU Control Output Memory Area

Words	Name	Bit	Bit name	Function
n	PCU Control Command Bits	13	Read Data Bit	Turn ON this bit to start reading data.
n+1	Number of Data Transfer Words	0 to 15	—	Set the number of words to read or write. When transferring slave parameters, specify the data size of the slave parameters in bytes.
n+2	CPU Unit Data Transfer Area	0 to 15	—	Set the area in the CPU Unit. 00B0 (hex): Core I/O Area (CIO Area) 00B1 (hex): Work Area (WR Area) 00B2 (hex): Holding Area (HR) 0082 (hex): DM Area (DM) 0050 to 0068 (hex): EM Area (EM) ^{*1} 0050 (hex): EM bank 0 0051 (hex): EM bank 1 : 0068 (hex): EM bank 24 00A0 to 00AF (hex): EM Area (EM) ^{*2} 00A0 (hex): EM bank 0 00A1 (hex): EM bank 1 : 00AF (hex): EM bank F

Words	Name	Bit	Bit name	Function
n+3	CPU Unit Data Transfer Beginning Word	0 to 15	–	Set the beginning word in the CPU Unit. Specify the first word in the I/O memory of the CPU Unit that contains the data to transfer. This word will be in the data transfer area that was set. Example: To specify D00100 CPU Unit Data Transfer Area (n+2): 0082 (hex) CPU Unit Data Transfer Beginning Word (n+3): 0064 (hex)
n+4	PCU Data Transfer Area	0 to 15	–	Set the area in the PCU. Set the value in hexadecimal.
n+5	PCU Data Transfer Beginning Word ^{*3}	0 to 15	–	Set the address of beginning word 1 in the PCU. Set the value in hexadecimal.
n+6	PCU Data Transfer Beginning Word 2 ^{*4}	0 to 15	–	Set the address of beginning word 2 in the PCU. Set the value in hexadecimal.

*1. CJ2 CPU Units. The number of banks that can be used depends on the model of the CPU Unit.

*2. CJ1 CPU Units. The number of banks that can be used depends on the model of the CPU Unit.

*3. If the Servo Drive Parameter Area is selected for the PCU Area, the setting of this parameter functions as an index.

*4. If the Servo Drive Parameter Area is selected for the PCU Area, the setting of this parameter functions as a subindex.

PCU Control Input Memory Area

Words	Name	Bit	Bit name	Function
n+11	PCU Control Command Acknowledged Flags	13	Read Data Acknowledged Flag	This flag turns ON to acknowledge the Read Data Bit.
n+12	PCU Control Status	0	Data Transfer Flag	This flag remains ON while the data transfer is in progress.
		1	Data Transfer Invalid Flag	This flag turns ON when the data transfer fails.
		2	Data Transfer Completed Flag	This flag turns ON when a data write, data read, or data save operation is completed successfully.

Procedure

1. Specify the data in words n+1 to n+6.

Specify the Number of Data Transfer Words (word n+1), CPU Unit Data Transfer Area (word n+2), CPU Unit Data Transfer Beginning Word (word n+3), PCU Data Transfer Area (word n+4), PCU Data Transfer Area Beginning Word (word n+5), and PCU Data Transfer Area Beginning Word 2 (word n+6).

2. Turn ON the Read Data Bit (word n, bit 13) to read the data from the PCU.

Timing Chart

The following chart shows the timing of reading data.

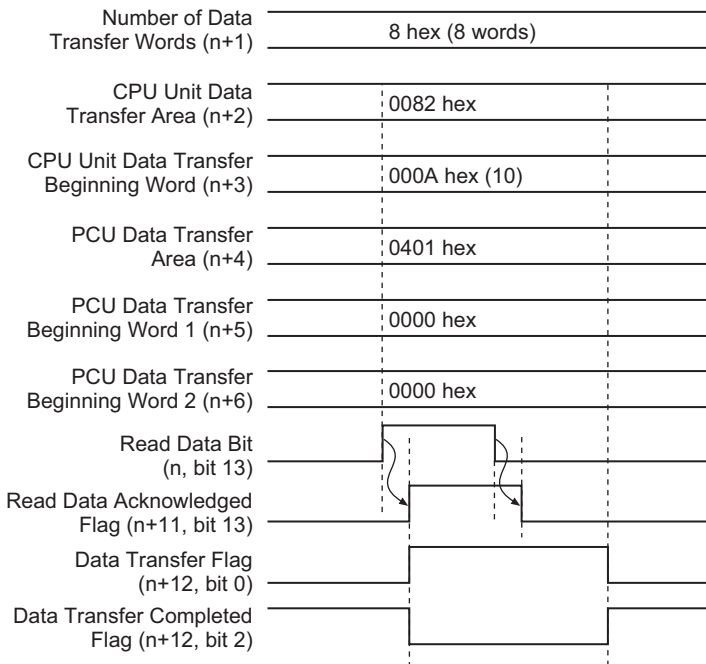

When data reading is completed, the Data Transfer Completed Bit (word n+12, bit 2), which is the same as for writing data, turns ON.

If an error occurs when data is written, the Data Transfer Invalid Flag (word n+12, bit 1) will turn ON and the error code will be output to word n+14.

Programming Example 1

This section provides a programming example that reads the following position data from the PCU. The PCU is set to unit number 3.

Data to be Transferred

The data to be read is the configuration axis 1 command position, configuration axis 2 command position, and configuration axis 3 command position of sequence 1.

The first word of the transfer destination is D00010 and the settings are given in the following table.

Task number	Parameter type	Sequence number	Transfer source name	Transfer source address	Transfer destination area	Content to be read
1	0401 hex	1	Configuration axis 1 command position (lower word)	0000 hex	D00010	2710 hex
			Configuration axis 1 command position (upper word)	0001 hex	D00011	0000 hex (10000)
			Configuration axis 2 command position (lower word)	0002 hex	D00012	3A98 hex
			Configuration axis 2 command position (upper word)	0003 hex	D00013	0000 hex (15000)
			Configuration axis 3 command position (lower word)	0004 hex	D00014	4650 hex
			Configuration axis 3 command position (upper word)	0005 hex	D00015	0000 hex (18000)



Reference

The PCU Data Transfer Beginning Word 2 parameter is not used in this data transfer programming example.

Ladder Programming Example

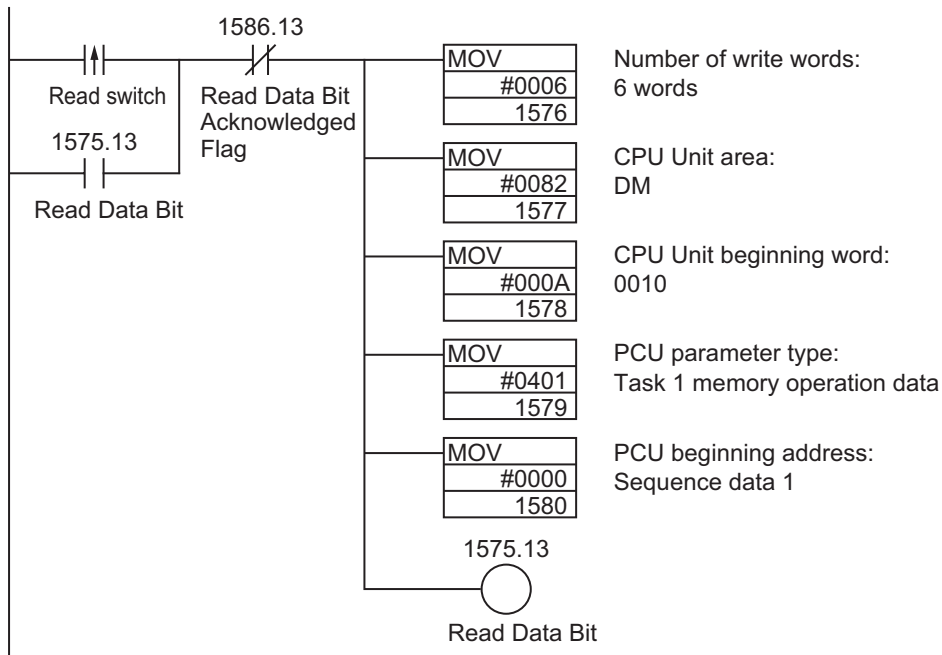

Programming Example 2

This programming example reads the slave parameters (Servo Drive objects) for an OMRON G5-series Servo Drive.

The PCU is set to unit number 3.

Data to be Transferred

The data to be read is the error code (index: 603F hex, sub-index: none (0)) of the G5-series Servo Drive at node address 2 (axis 2).

603F hex	Error code						All
Setting range	0000 hex to FFFF hex	Unit	–	Default	0000 hex	Data attribute	–
Size	22 bytes (U16)		Access	RO	PDO mapping	Possible	

- ♦ The errors that are indicated are manufacturer-specific errors between FF00 and FFFF hex.
- ♦ The lower byte, FF00 to FFFF hex, indicates the main number of the error number.

The first word of the transfer destination is D00010 and the settings are given in the following table.

Node address (axis number)	Parameter type	Transfer source name	Object name	Source address 1 (index)	Source address 2 (sub-index)	Number of words to transfer	Transfer destination area
2	3002 hex	Node address 2 slave parameters	Error code	603F hex	0	2 (bytes)	D00010

Ladder Programming Example

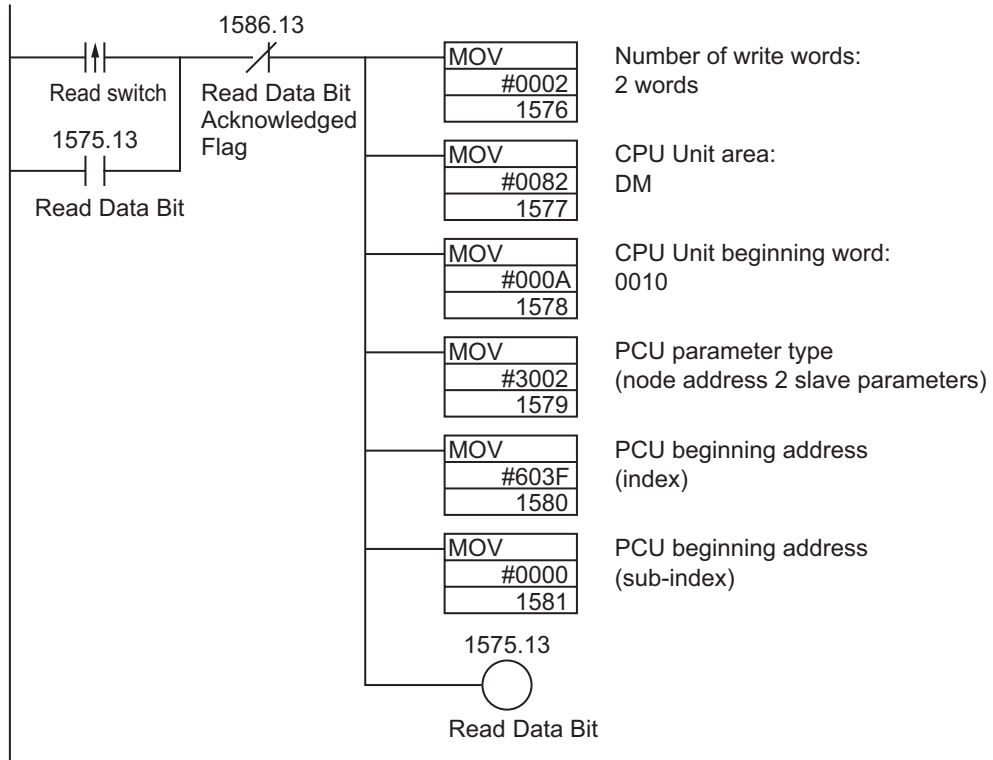

9-4 Writing Data with IOWR(223)

This section provides the procedure and a programming example for writing data to the PCU by using the IOWR(223) instruction.



Precautions for Correct Use

- ♦ Write data for only one parameter with each IOWR(223) instruction for common parameters, axis parameters, or memory operation parameters.
 - ♦ When you write memory operation data with the IOWR(223) instruction, do not transfer data for more than one sequence at the same time. Always transfer data for only one sequence with each IOWR(223) instruction.
-

Writing Procedure

The procedure for writing data with the IOWR(223) instruction is given below.

1. Set the IOWR(223) instruction.

C: FParameter type for transfer

S: FFirst word in CPU Unit

W: FTransfer destination PCU unit number and number of words to write

2. Data Settings

Set the data to write starting from the specified first word, S.

3. Execute the data write.

Execute the IOWR(223) instruction.

IOWR(223) Instruction Specifications

This section describes the format of the IOWR(223) instruction. For details, refer to *CS/CJ-series PLC Instructions Reference Manual* (Cat. No. W474).

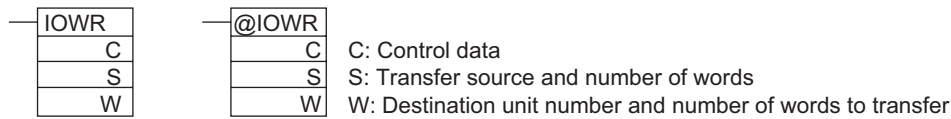

Operand	Description
C	Set the parameter type in the PCU in hexadecimal.
S	Specify the first word where you set the data to be transferred in the CPU Unit.
W	PCU unit number to which to transfer data W+1: Number of data transfer words For parameters, specify the data for only one type of parameter. For memory operation data, specify the data for only one sequence. For memory operation condition data, specify only one condition.

C: Control Data

Specify the parameter type of the data to be written in hexadecimal.

For common parameters, axis parameters, or memory operation parameters you can write to only one unit address with each instruction. You cannot write multiple parameters with one instruction.

For memory operation data and memory operation condition data you can write to only one sequence or one condition with each instruction. You cannot write the data for multiple sequences or multiple conditions with one instruction.

S: First Word of Transfer Source Data

Place the data to be transferred starting in the specified word S, as shown below.

Words	Set data	Description
S	Unit address	Set the unit address of the data to be transferred in hexadecimal.
S+1 S+2	Transfer data	Set the data to be transferred. When transferring 2 words, set the lower word data in S+1 and the upper word data in S+2.

The transfer data is as follows when transferring slave parameters:

Words	Set data	Description
S	Data size	Specify the data size of the objects being transferred in bytes.
S+1	Index	Set the index for the slave in the object dictionary.
S+2	Sub-index	Set the sub-index for the slave in the object dictionary. If there is no sub index, set 0000 hex.
S+3 S+4	Transfer data	If there is only one word of data, set it in S+3. If there are two words of data, set the lower word in S+3 and the upper word in S+4.

W: Transfer Destination Unit Number and Number of Transfer Words

Set the unit number of the PCU to which the data is to be transferred, and the total number of words of the data to be transferred.

Transfer destination unit number: 8000 to 800F hex (unit number + 8000 hex)

Number of transfer words: Set the number of words of the data to be transferred + 1.
The number of words to transfer is always 5 words for slave parameters.

Example:

The following setting would be used to transfer the Jogging/Inching Speed 1 axis parameter to the PCU with unit number 5.

#00038005 (Number of transfer words: 0003 [3 words], unit number 8005 [No. 5])



Condition Flag Operation

Name	Label	Description
Error Flag	P_ER	<ul style="list-style-type: none"> • Turns ON when the number of transfer words specified in D is not between 1 and 128 (0001 to 0080 hex). • Turns ON when the unit number (D) is not between 0 and 95 decimal (0000 and 005F hex) or 8000 and 800F hex. • Turns ON when you specify a constant for S and the number of words to transfer (D) is not 1. • Turns ON when the specified CPU Bus Unit is on a SYSBUS Slave Rack. • Turns ON when you specify a Special I/O Unit or a CPU Bus Unit that does not support the IOWR(223) instruction. • Turns ON if there is a setting error or other error in the PCU. • Turns ON when the write could not be completed normally because the control data, number of transfer words, or transfer data is out of range. (An overall warning will also occur.) • Otherwise OFF.
Equals Flag	P_EQ	<ul style="list-style-type: none"> • Turns ON when the writing process is completed successfully. • Turns OFF when the writing process is not completed successfully. • Turns OFF when the intelligent transfer that was previously requested has been completed.

Note 1. The Equals Flag will turn OFF and the Error Flag will turn ON if a write cannot be completed normally because the PCU is busy.

Note 2. An error will occur if there is an I/O Unit verification error, CPU Bus Unit setting error, or CPU Bus Unit error in the PCU.

Operation

The data for the number of transfer words (W+1) from the first transfer source word specified in S is written to the memory of the PCU with the unit number specified in D. The PCU must be mounted to the CPU Rack or an Expansion Rack.

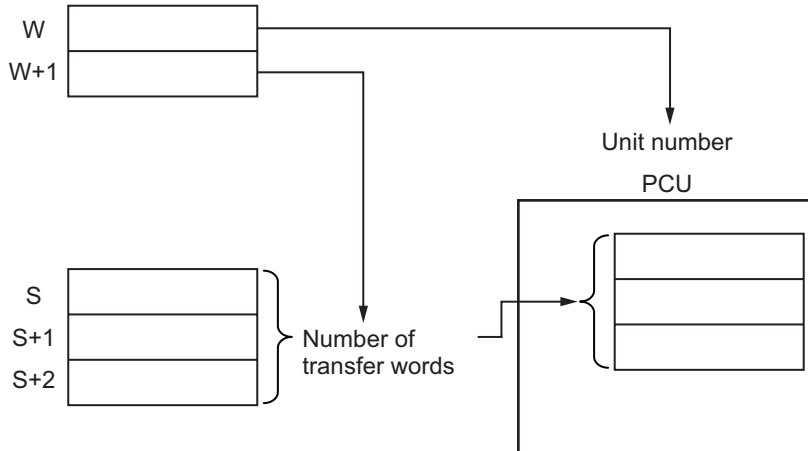

Program Example

This section provides a programming example that writes the following position data to the PCU. The PCU is set to unit number 2.

Data to be Transferred

The first word of the data to be transferred is D00100 and the settings are given in the following table.

Task number	Parameter type	Sequence number	Transfer destination name	Transfer destination address	Transfer source area	Content to be written
1	0401 hex	1	Configuration axis 2 command position (lower word)	0002 hex	D00101	3A98 hex
			Configuration axis 2 command position (upper word)	0003 hex	D00102	0000 hex (15,000)
			Configuration axis 3 command position (lower word)	0004 hex	D00103	4650 hex
			Configuration axis 3 command position (upper word)	0005 hex	D00104	0000 hex (18,000)

The following data is also required.

Transfer source area	Data to be written	Content of transfer
D00100	0002 hex	Transfer destination address
D00200	8002 hex	Unit number 2
D00201	0005 hex	Number of transfer words

Ladder Programming Example

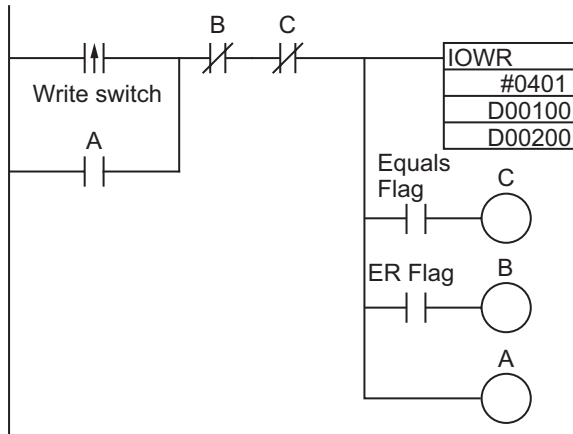

Reference

- When you execute the IOWR(223) instruction, the execution result is saved in the Condition Flags. The Equals Flag will turn ON when the write has been completed. Input Condition Flags, such as the Equals Flag, on branches from the same input condition as the IOWR(223) instruction.
- The IOWR(223) instruction is not executed as an interrupt for CPU Bus Units. It will therefore not be executed immediately, but rather over multiple cycles. Create a self-holding loop, as shown below, so that IOWR will be executed until the Equals Flag turns ON.
- Only one Intelligent Instruction or Interrupt Instruction (NCDMV or NCDTR) can be executed at the same time for the same CPU Bus Unit. Create the program so that only one of these instructions is executed at a time. When using IOWR instructions continuously to transfer data, make sure that the Equals Flag turns ON for one IOWR instruction before executing the next IOWR instruction. (Refer to the programming example.)
- If you place a Condition Flag after a different instruction, the Condition Flag may change according to the execution result of the other instruction. Be sure to place any Condition Flags immediately after the IOWR(223) instruction.

9-5 Reading Data with IORD(222)

This section provides the procedure and a programming example for reading data from the PCU by using the IORD(222) instruction.

You can use an IORD(222) instruction to read the feedback counter present value or latch data for each axis.

Reading Procedures

The procedure for reading data with the IORD(222) instruction is given below.

Procedure

1. Set the IORD(222) instruction.

- C: PCU parameter type
- W: Transfer source PCU unit number and number of words to read
- D: First word in CPU Unit

2. Execute the data read.

Execute the IORD(222) instruction.

IORD(222) Instruction Specifications

This section describes the format of the IORD(222) instruction. For details, refer to *CS/CJ-series PLC Instructions Reference Manual* (Cat. No. W474).

—	IORD	—	@IORD	
	C		C	C: Control code
	W		W	W: Destination unit number and number of words to transfer
	D		D	D: First word number of transfer destination

Operand	Description
C	Set the parameter type in the PCU in hexadecimal.
W	Set the unit number of the transfer source PCU and the number of words to read.
D	Set the first word of the transfer destination in the CPU Unit.

C: Control Data

Specify the parameter type of the data to be read in hexadecimal.

The following two types of data can be read with the IORD(222) instruction.

Axis 1 to axis 16 feedback counter present values:	1101 to 1110 hex
Axis 1 to axis 16 present position latch data:	1201 to 1210 hex
Axis 1 to axis 16 origin position latch data:	1301 to 1310 hex

W: Transfer Source Unit Number and Number of Transfer Words

Specify the unit number for the data transfer source, and the total number of words of the data to be transferred.

Transfer source unit number: 8000 to 800F hex

Number of transfer words: Set the number of words of the data to be transferred.

The number of transfer words is always 2.
because the data that can be read with the IORD(222) instruction are only the feedback counter present value and the capture data.

Example:

If you read the axis 1 feedback counter present value from the PCU with unit number 5, set the following data

#00028005 (Number of transfer words: 0002 [2 words], unit number 8005 [No. 5])

D: First Word Number of Transfer Destination

Set the first word of the transfer destination in the CPU Unit.

Condition Flag Operation

Name	Label	Description
Error Flag	P_ER	<ul style="list-style-type: none"> ◆ Turns ON when the number of transfer words specified in D is not between 1 and 128 (0001 to 0080 hex). ◆ Turns ON when the unit number (D) is not between 0 and 95 decimal (0000 and 005F hex) or 8000 and 800F hex. ◆ Turns ON when the specified CPU Bus Unit is on a SYSBUS Slave Rack. ◆ Turns ON when you specify a Special I/O Unit or a CPU Bus Unit that does not support the IORD(222) instruction. ◆ Turns ON if there is a setting error or other error in the PCU. ◆ Turns ON when the write could not be completed normally because the control data, number of transfer words, or transfer data is out of range. (An overall warning will also occur.) ◆ Otherwise OFF.
Equals Flag	P_EQ	<ul style="list-style-type: none"> ◆ Turns ON when the reading process is completed successfully. ◆ Turns OFF when the reading process is not completed successfully. ◆ Turns OFF when the intelligent transfer that was previously requested has been completed.

Note 1. The Equals Flag will turn OFF and the Error Flag will turn ON if a write cannot be completed normally because the PCU is busy.

Note 2. An error will occur if there is an I/O Unit verification error, CPU Bus Unit setting error, or CPU Bus Unit error in the PCU.

Operation

The data for the number of transfer words in the memory in the PCU that is specified by the unit number in S is read and stored starting at D.

The PCU must be mounted to the CPU Rack or an Expansion Rack.

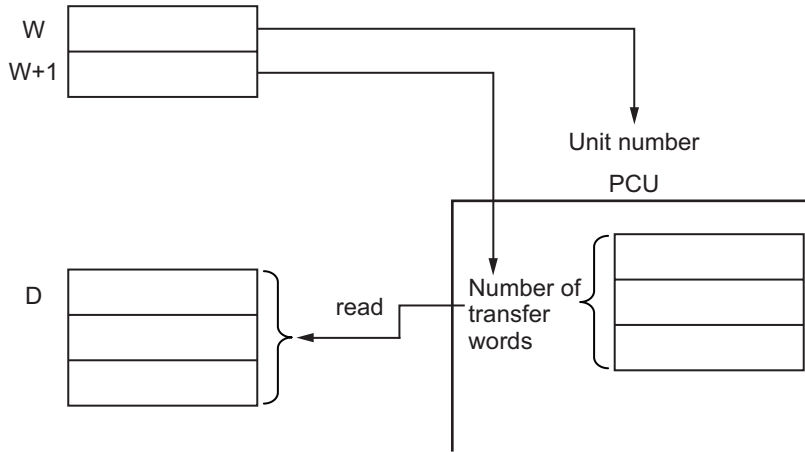

Program Example

This section provides a programming example that reads the following position data from the PCU. The PCU is set to unit number 2.

Data to be Transferred

The first word of the transfer destination is D00300 and the settings are given in the following table.

Parameter type	Transfer source name	Transfer Destination area
1101 hex	Axis 1 feedback counter present value	D00300

The following data is also required.

Transfer source area	Data to be written	Content of transfer
D00400	8002 hex	Unit number 2
D00401	0002 hex	Number of transfer data (Always 0002.)

Ladder Programming Example

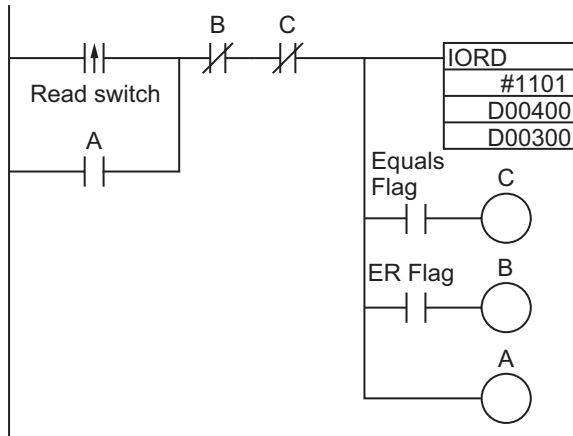

Reference

- ♦ When the IORD instruction is executed, the results will be shown in the Conditions Flags. The Equals Flag will turn ON when the write has been completed. Input Condition Flags, such as the Equals Flag, on branches from the same input condition as the IORD(222) instruction.
- ♦ The IORD instruction is not executed as an interrupt for CPU Bus Units. It will therefore not be executed immediately, but rather over multiple cycles. Create a self-holding loop, as shown below, so that IORD will be executed until the Equals Flag turns ON.
- ♦ Only one Intelligent Instruction or Interrupt Instruction (NCDMV or NCDTR) can be executed at the same time for the same CPU Bus Unit. Create the program so that only one of these instructions is executed at a time. When using IORD instructions continuously to transfer data, make sure that the Equals Flag turns ON for one IORD instruction before executing the next IORD instruction. (Refer to the programming example.)
- ♦ If you place a Condition Flag after a different instruction, the Condition Flag may change according to the execution result of the other instruction. Be sure to place the Condition Flags immediately after the IORD(222) instruction.

9-6 Data Transfer with CX-Programmer

You can use the CX-Programmer to write data, read data, save data, and monitor PCU operating status.

Transfer Procedure

1. In the PCU Setting Window, select Transfer Selection [PC to NC] from the PCU Setting Window.

The following dialog box will appear.

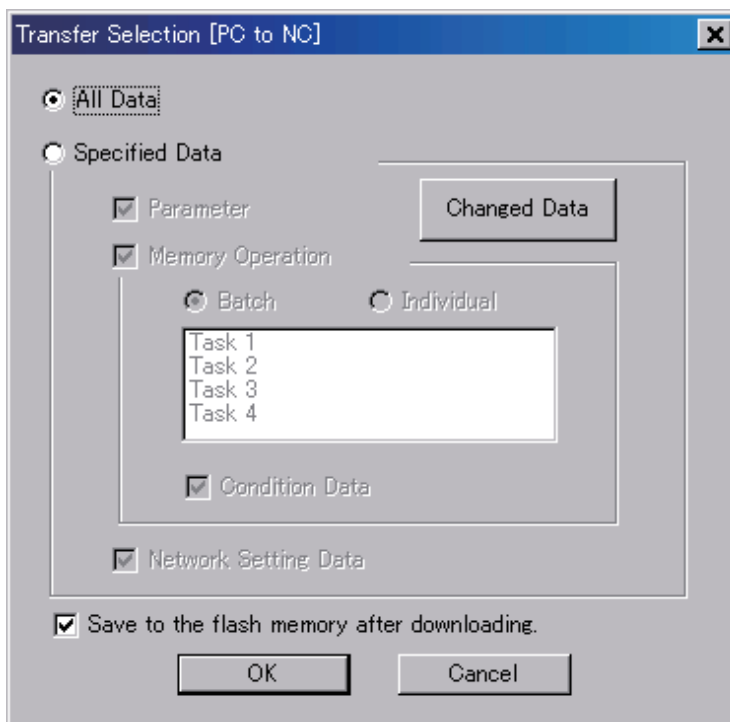

2. Select the applicable option.

Item	Function	
All Data	Select this option to transfer all data. If you select the All Data Option, you cannot select the Specified Data Option.	
Specified Data	Select this option to transfer the following individual data. If you select Specified Data Option, you cannot select All Data Option.	
	Parameter	Select this check box to transfer common parameters, axis parameters, or task parameters. If you click the Changed Data Button, the parameters that have been edited will be transferred.
	Memory Operation	Select this check box to transfer memory operation data. Tasks must be registered to select this check box. If you select the Batch Option, data for all tasks will be transferred. If you select the Individual Option, only the tasks in the list will be transferred (multiple selections are permitted).
	Memory Operation Condition Data	Select this check box to transfer the memory operation condition data.
	Network Setting Data	Select this check box to transfer the network settings.
Save to the flash memory after downloading.	Select this check box to save the data to the flash memory after the transfer.	

3. Click the OK Button to transfer the data.



Precautions for Correct Use

- ♦ Do not execute more than one transfer at a time from the CX-Programmer for the same PCU. Doing so may cause the data transfer to be executed improperly and result in unexpected operation.
- ♦ Transferring parameters can be canceled by pressing the Cancel Button during the transfer. However, if you cancel transferring network settings, a CPU Bus Unit memory error (communications parameters) (error code: 0014) will occur in the PCU after the transfer is canceled. If that occurs, transfer the correct settings.
- ♦ If data created for a new unit version of the PCU is transferred to an old unit version of the PCU, an error message will be displayed if the data contains unsupported settings and the data transfer will be canceled.
Check the unit version of the mounted Unit and the settings, and transfer the data again.

9-7 Saving Data

Unless you save the data, the data that you transfer to the PCU will be lost if you turn OFF the PLC power supply or restart the PCU. Save the transferred data to the internal flash memory in the PCU to keep the data. After you save the data, you can then use the saved data when you turn ON the power supply or restart the PCU.

When you save the data, you save all of the current parameters and data.



Precautions for Correct Use

- ◆ Do not turn OFF the power supply or restart the PCU while data is being saved. It may cause a failure of the internal flash memory in the PCU. Consequently, you may not be able to operate the PCU properly.
- ◆ If you save data when there is a flash memory failure, a CPU Bus Unit memory error (user data) (error code: 0010) will occur. It may take up to 30 seconds to save the data.
- ◆ The flash memory in the PCU can be written a maximum of 100,000 times. The flash memory may fail if this limit is exceeded. Do not save the data too frequently.
- ◆ Save the data only when a data transfer command is not being executed. If you execute the save operation in any other conditions, the data save will not be executed, and a multi-start error (error code: 8200) will occur.
- ◆ Data that is set in the slave, such as the slave parameters, is not saved for the data save operation of the PCU. Use the save operation for each slave to save the slave data.

Data To Be Saved

The data stored in the PCU will be lost if you turn OFF the PLC power supply or restart the PCU. You can save the contents of the internal memory to flash memory to save the parameters and data by performing the data save operation.

The following data is saved to a flash memory.

- ◆ Common parameters
- ◆ Axis Parameters
- ◆ Task memory operation parameters
- ◆ Memory operation data
- ◆ Memory operation condition data

All of the data for the number of axes supported by the PCU is saved at the same time.

The parameters and the data that are saved to flash memory are written into the internal memory in the PCU when you turn ON the power supply or restart the PCU.

At that time, if the parameters or the data on the flash memory is damaged, a CPU Bus Unit memory error (user data) (error code: 0010) will occur, and the PCU will start with the default settings.



Reference

- ◆ If parameter or data corruption occurs, operations other than to transfer and save data are not allowed. Execute the data save operation, or execute it after data transfer, and then cycle the power supply or restart the PCU.

Executing a Data Save Operation

Use the Save Data Bit in the PCU Control Output Memory Area or use the CX-Programmer.

Using the Save Data Bit

The words and bits that are necessary for transfer are listed in the following table.

PCU Control Output Memory Area

Words	Name	Bit	Bit name	Function
n	PCU Control Command Bit	14	Save Data Bit	Turn ON this bit to start saving data.

PCU Control Input Memory Area

Words	Name	Bit	Bit name	Function
n+11	PCU Control Command Acknowledged Flags	12	Write Data Acknowledged Flag	This flag turns ON to acknowledge the Write Data Bit.
		14	Save Data Acknowledged Flag	This flag turns ON to acknowledge the Save Data Bit.
		15	PCU Ready Flag	This flag turns ON when the PCU is ready.
n+12	PCU Control Status	0	Data Transfer Flag	This flag remains ON while the data transfer is in progress.
		1	Data Transfer Invalid Flag	This flag turns ON when the data transfer fails.
		2	Data Transfer Completed Flag	This flag turns ON when a data write, data read, or data save operation is completed successfully.
		3	Save Data Request Bit	This flag turns ON whenever data will be lost if you turn OFF the power supply without saving the data.

Timing Chart

You cannot save and transfer data at the same time. Doing so will result in a multi-start error (error code: 8200).

Data can be saved during reference output.

The following chart shows the chart for saving data.

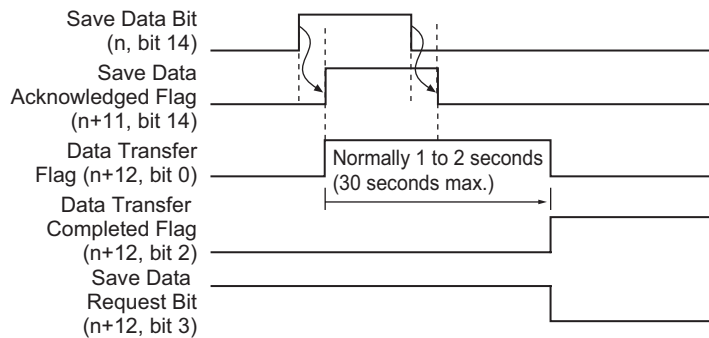

When saving data is completed, Data Transfer Completed Bit (word n+12, bit 2) turns ON.

Saving Data with the CX-Programmer

The procedure for saving data with the CX-Programmer is given below.

1. **Connect the CX-Programmer online to the PLC.**
2. **Display the PCU Setting Window.**
3. **Select Write Flash Memory from the NC Unit Menu.**

9-8 PCU Setup

If you change a parameter that requires the power supply to be cycled, you normally need to restart the PCU. If the power supply is cycled, the CPU Unit will stop until power is restored.

The PCU setup function is provided so that the PCU can be restarted without stopping the CPU Unit.

Outline of Operation

The PCU setup function can be used to initialize the PCU without stopping CPU Unit operation. You can use the PCU setup function regardless of the status of the PCU by turning ON the PCU Setup Bit in the PCU Control Output Memory Area.

When you execute the function, all output signals of the PCU are turned OFF.

When setup has been completed, the PCU Ready Flag will turn ON and the output bits from the CPU Unit will be output to the PCU output signals.

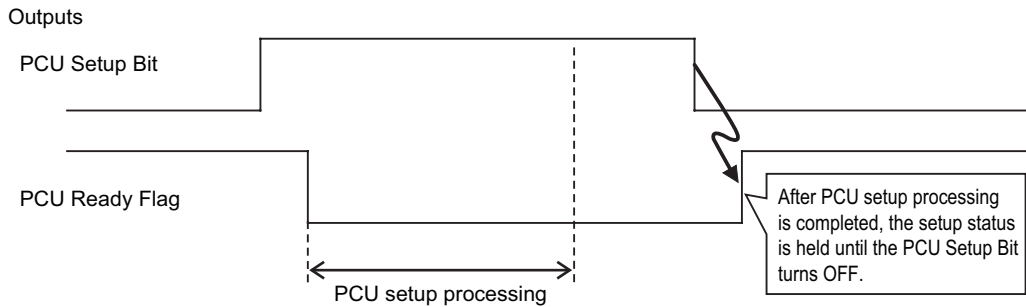

PCU Operating Modes

The PCU has the following operating modes. The operations that can be performed from the PLC depend on the operating mode.

Operating mode	Description of operating status	PLC status			Operation from PLC
		PCU Ready Flag	EtherCAT communications control state	PDO communications output	
Initializing Mode	The PCU is in Initializing Mode from when you turn ON the power supply or restart the PCU until the PCU and EtherCAT communications start. In this mode, the PCU Ready Flag (word n+11, bit 15) ^{*1} is OFF.	OFF	Init to Safe-Operational	–	Not possible.
PCU Setup Mode	In this mode, the PCU Setup Flag (word n, bit 15) ^{*1} is ON and the PCU Ready Flag is OFF.	OFF	Pre-Operational	–	Only the PCU Control Memory Area will operate.
Support Software-controlled Data Transfer Mode	Support Software-controlled Data Transfer Mode is entered in response to a command from the CX-Programmer. In this mode, data can be transferred to and from the CX-Programmer. Ladder program outputs are disabled.	OFF	Pre-Operational	–	Not possible.
Support Software-controlled Operation Mode	Support Software-controlled Data Transfer Mode is entered in response to a command from the CX-Programmer. In this mode, operation from the CX-Programmer is possible. Ladder program outputs are disabled.	OFF	Operational	This output status prior to entering Support Software-controlled Operation Mode will be held.	Not possible.
Normal Operation Mode ^{*2}	In Normal Operation Mode, the PCU Ready Flag is ON.	ON	Operational	Normal operation	Enabled Flag

*1. "Word n" is the first word allocated to the PCU in the CPU Bus Unit Area. You can calculate the first word in the CPU Bus Unit Area using the following formula: First word allocated to PCU in CPU Bus Unit Area, $n = \text{CIO } 1500 + 25 \times \text{unit number}$

*2. Turn OFF the PCU Setup Bit (word n bit 15) to return to normal operation during PCU setup.

9-9 Simple Backup

If you mount the PCU on the PLC, all data within the CPU Unit and the internal data in the PCU can be backed up to a Memory Card, restored from the Memory Card, and verified by using a simple backup operation from the CPU Unit.

Outline of Operation

The following data in the internal flash memory of the PCU is backed up, restored, and verified.

- ♦ Parameters (common parameters, axis parameters, and memory operation parameters)
- ♦ Memory operation data
- ♦ Memory operation condition data
- ♦ Network configuration information
- ♦ Communications settings

The above data in the internal flash memory of the PCU is backed up on the Memory Card in a file with the following name.

File name: BACKUP□□.PRM

(Note: □□ = unit number + 10 hex)

You can also read and verify this file from the Memory Card.

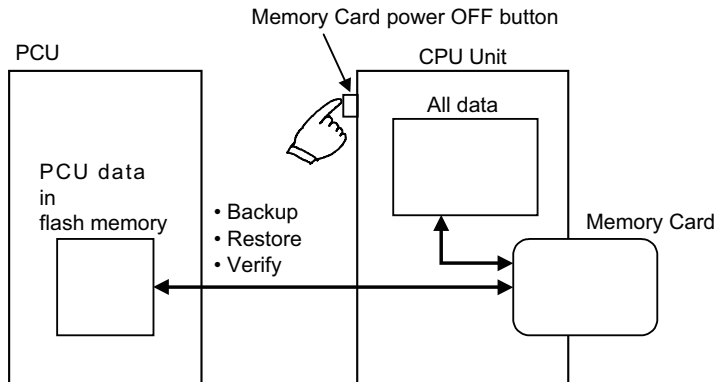

Precautions for Correct Use

Slave parameters are not included in the simple backup data.

Application

You can back up the data from the entire PLC, which includes the CPU Unit, PCUs, DeviceNet Units, Serial Communication Units/Boards. You can transfer all data at once by using this function. It is thus a convenient function when you replace Units.

Procedures

This section describes the procedures for backing up, restoring, and verifying data.

Backing Up Data

Transferring data from the PCU to a Memory Card is referred to as a backup.

Set the DIP switch on the front of the CPU Unit as shown below, and then hold down the Memory Card power OFF button for 3 seconds.

DIP switch on the front of the CPU Unit	
SW7	SW8
ON	OFF

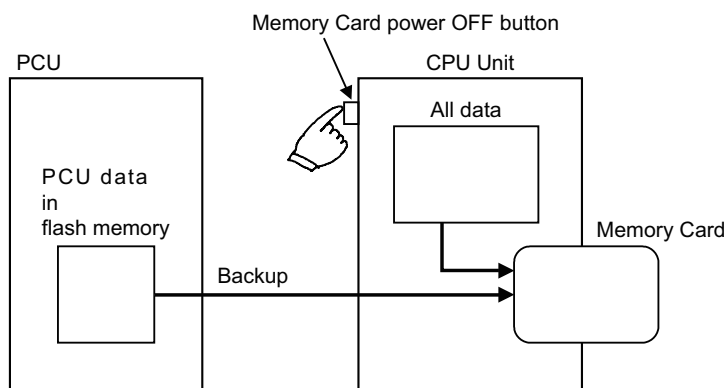

When this procedure is performed, a PCU data file is created and written to the Memory Card along with other backup files.

When you hold down the Memory Card power OFF button, the MCPWR indicator on the front of the CPU Unit flashes once, and then turns ON while the data write is in progress. It turns OFF after the data write is completed successfully.



Reference

The data can be backed up regardless of the operating mode of the CPU Unit.



Precautions for Correct Use

- Do not save data to flash memory in the PCU during the backup operation. It may corrupt the backup data.
- Do not perform a backup operation when flash memory data is corrupted. If corrupted memory is backed up, a data error will occur when restoring the data.
- The data backed up using the simple backup function includes absolute encoder backup data. This means that you will also restore absolute encoder related information such as the Absolute Encoder Origin Position Offset parameter. If you are using an absolute encoder and the encode status has changed since backup, the restored data may not reflect the present position correctly.

Restoring Data

Transferring data from a Memory Card to the PCU is referred to as restoring data.

Set the DIP switch on the front of the CPU Unit as shown below, and turn the power supply of the CPU Unit OFF and then back ON.

DIP switch on the front of the CPU Unit	
SW7	SW8
ON	OFF

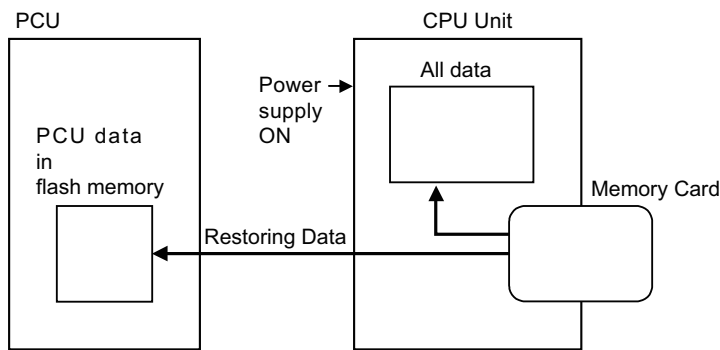

When this procedure is performed, the PCU data file on the Memory Card is read and the data is restored to the PCU.

When the power supply turns ON, the MCPWR indicator on the front of the CPU Unit turns ON and flashes once, and then turns ON while the data restore operation is in progress. It turns OFF after the data restore operation is completed successfully.



Precautions for Correct Use

- ♦ With the simple backup function, you must restore the data to a PCU with the same model number. You cannot restore the data to a PCU with a different model number.
- ♦ The simple backup function does not provide upward compatibility when restoring data. The backup data can be restored to a PCU with the same unit version or a later unit version.



Reference

- ♦ When you restore data, the data is read from the Memory Card onto the RAM of the PCU, and then checked. If the operation is normal, the data is automatically written to the flash memory. If the operation is not normal, a CPU Bus Unit memory error (user data) (error code: 0010) will occur.

Verifying Data

Comparing the data in the PCU and the data on a Memory Card is referred to as verification.

Set the DIP switch on the front of the CPU Unit as shown below, and then hold down the Memory Card power OFF button for 3 seconds.

DIP switch on the front of the CPU Unit	
SW7	SW8
OFF	OFF

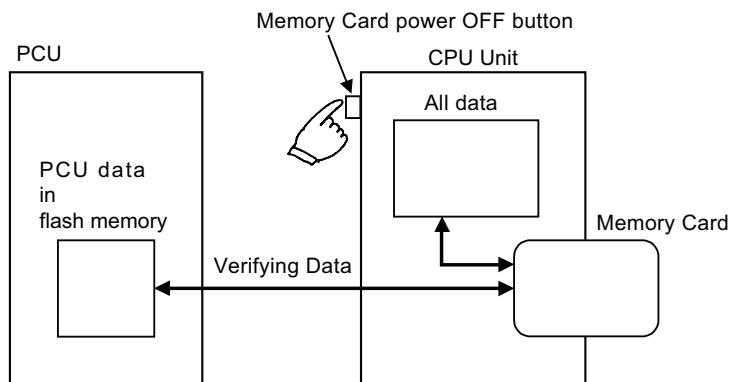

When this procedure is performed, the data on the Memory Card and the data in the internal flash memory of the PCU are compared.

When you hold down the Memory Card power OFF button, the MCPWR indicator on the front of the CPU Unit flashes once, and then turns ON while the verification is in progress. The indicator turns OFF after verification if the data on the Memory Card and in the flash memory are the same. The MCPWR indicator will flash if the data is not the same.



Precautions for Correct Use

Do not save data to flash memory in the PCU during the verification operation. It may make the verification results inaccurate.

10

Operating Functions

This section describes the auxiliary operation functions, such as feedback position monitoring, interrupt feeding, overrides, and teaching, that can be used in combination with an OMNUC G5-series Servo Drive.

10-1 Feedback Position Monitoring.....	10-1
10-2 Interrupt feeding	10-7
10-3 Overrides	10-13
10-4 Torque Limits	10-19
10-5 Teaching	10-23
10-6 Positioning Completion.....	10-25
10-7 Present Position Latch.....	10-28
10-8 Origin Position Latch.....	10-31

10-1 Feedback Position Monitoring

With the PCU, the position control loop is in the Servo Drive regardless of whether the application uses a semi-closed loop or full-closed loop.

However, the PCU can input the encoder feedback position.

You can use either an incremental encoder or absolute encoder.

Outline of Operation

The functional purpose of the feedback position counter in the PCU is to check operation for command positions.

Depending on the settings, the command present position and feedback position can be updated in both directions to enable using the feedback position for position monitoring.

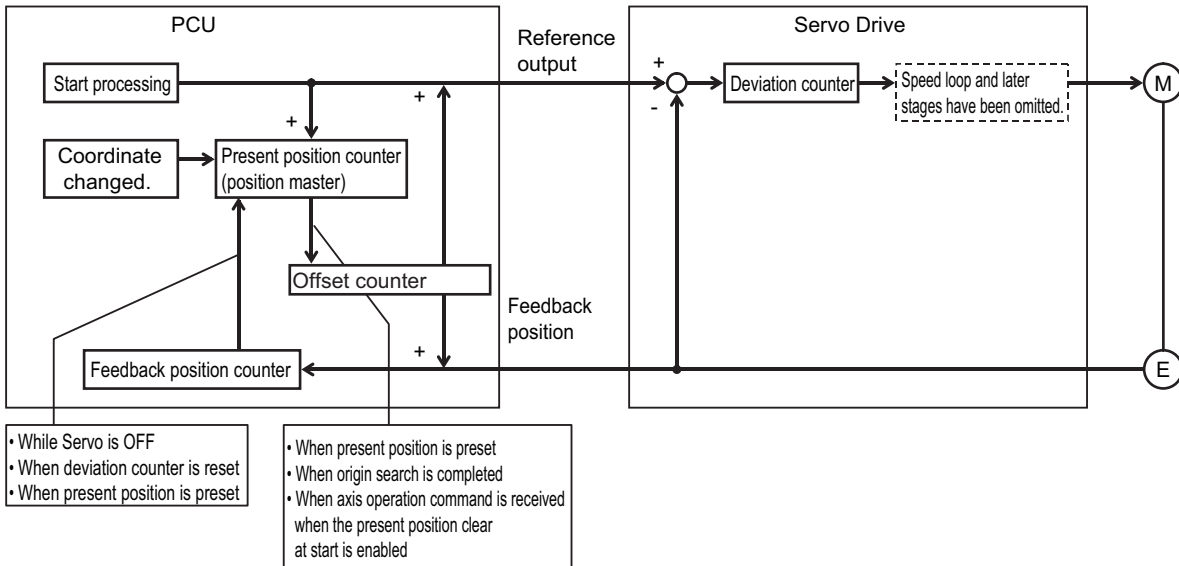

Reference

- ♦ The feedback position can be monitored in any of the CSP, CSV, and CST modes.

The following table shows how the command position and feedback position change at various times during operation.

Item	Present position counter	Feedback position counter
Power supply turned ON	0	0
While servo is unlocked	Always updated with the feedback position count value. ^{*1}	Feedback position count value
While servo is being locked	Command count value Read absolute data for a motor with an absolute encoder ^{*2}	Feedback position count value Read absolute data for a motor with an absolute encoder ^{*2}
With servo locked (axis stopped or axis operating)	Command count value	Feedback position count value
When present position is preset	Preset command value	Preset command value
When origin search is completed	0 or origin search preset value	0 or origin search preset value
When present position clear is enabled at startup	Preset to 0.	Preset to 0.
When deviation counter is reset	The feedback position count value is preset. ^{*3}	No change The current feedback position is held.

*1. Even if you unlock the servo after the origin is defined by an origin search or other method, the defined origin is held.

*2. When a motor with an absolute encoder is connected, the present position counter and feedback position counter are preset to the absolute data when the servo is locked.

*3. Resetting the deviation counter will not make the origin undefined and the previous origin defined status is held.



Reference

- If you want to directly preset a position in the feedback position counter, you can write the position only with an IOWR(223) instruction. For the addressed areas, refer to *Other Addresses* on page 9-24.

Axis Parameter Settings

To use feedback position monitoring, you must set axis parameters.

For axis parameters other than those which this section describes, refer to *6-4 Axis Parameters* on page 6-29.

Feedback Input Settings

Set the feedback method. For details, refer to *Feedback Input Settings* on page 6-57.

Parameter name	Function	Setting range	Unit	Default value
Encoder Type	0: Incremental encoder 1: Absolute encoder (OMNUC G5 Series)	0 to 1	–	0
Absolute Encoder Origin Position Offset	This parameter stores the compensation value for absolute encoder to be taken in when you execute absolute origin setting.	–	Command units	0

Expanded Monitor Type Settings

Select the type of expanded monitor to use. For details, refer to *Expanded Monitor Settings* on page 6-59.

Parameter name	Function	Setting range	Unit	Default value
Expanded Monitor Type* ¹	Select the type of expanded monitor to use. 0: Feedback present position 1: Command present position 2: Position deviation 3: Feedback present speed 4: Command present speed 5: Present torque 6: Command torque 7: Latch 1 value 8: Latch 2 value 9: Slave error code 10: Status word 11: Feedback present speed 2 12: Command present speed 2* ²	0 to 12	–	0

*1. New expanded monitor types introduced with version 1.3 include "6 (torque command data)", "8 (latch 2 value)", "11 (feedback present speed 2)", and "12 (command present speed 2)".

*2. During linear interpolation and circular interpolation in memory operation, and during synchronous position feeding, the same value as 4: Present command speed is displayed. This is 0 when unit performs a synchronous feeding torque operation.

Deviation Monitor Function Settings

Set the items that are necessary to monitor the position deviation between the command position and feedback position, and speed deviation between the command speed and feedback speed. For details, refer to *Deviation Monitor Function Settings* on page 6-61.

Parameter name	Function	Setting range	Unit	Default value
Speed Deviation Monitor Valid	Select whether to enable or disable the speed deviation monitor function. 0: Disabled, 1: Enabled	0 to 1	–	0
Position Deviation Monitor Valid	Select whether to enable or disable the position deviation monitor function. 0: Disabled, 1: Enabled	0 to 1	–	0
Feedback Speed Sampling Cycle	Set the sampling cycle at which to measure the feedback speed.	1 to 20	ms	10
Speed Deviation Monitor Dwell Time	Set the time from the start of the command speed output until the speed deviation monitor starts.	10 to 10,000	ms	1,000
Speed Deviation Limit name	Set the speed deviation to monitor.	1 to 65,000	–	100
Position Deviation Limit name	Set the position deviation to monitor.	1 to 65,000	Command units	100



Reference

To check whether the torque command is producing the required torque, create a ladder program that monitors the command torque and present torque values using the expanded monitor function to detect their difference.

Other Axis Parameters

Some of the position-related axis parameters are also used for command position parameters.

Software Limit Settings

The same zone settings are used. Use Software Limit Function Selection to select either the command position or feedback position.

Zone Settings

The same zone settings are used. Set the Zone 0 Function Selection, Zone 1 Function Selection and Zone 2 Function Selection to either the command position or feedback position.

Deviation between Axes Monitor Settings

With this function, all linear interpolation axes that use feedback positions will decelerate to a stop when the deviation between the feedback positions of two axes is equal to or greater than the value set for the Deviation between Axes Limit Value parameter.

This function is enabled only during linear interpolation.

Use the Deviation between Axes Monitor Settings to set this function. For details on the parameters, refer to *Deviation between Axes Monitor Settings* on page 6-74.

Parameter name	Function	Setting range	Unit	Default value
Deviation between Axes Monitor Enable	Select whether to monitor the feedback counter between axes. 0: Do not monitor, 1: Monitor	0 to 1	–	0
Deviation between Axes Limit Value	Set the allowable deviation in the feedback counter between axes.	0 to 65,535	Command units	0
Deviation between Axes Monitor Target Axis*1	Select the configuration axes to monitor. Bit 00: Turn ON to monitor configuration axis 1. Otherwise turn OFF. Bit 01: Turn ON to monitor configuration axis 2. Otherwise turn OFF. Bit 02: Turn ON to monitor configuration axis 3. Otherwise turn OFF. Bit 03: Turn ON to monitor configuration axis 4. Otherwise turn OFF.	0000 to 000F hex	–	0

*1. Do not specify axis numbers directly. Specify the configuration axis numbers.

This function allows you to perform bilateral operation of two axes based on completely identical command positions. This function is supported only for linear interpolation.

If a deviation occurs between the two axes due to a deviation in one axis, you can stop the axes automatically.

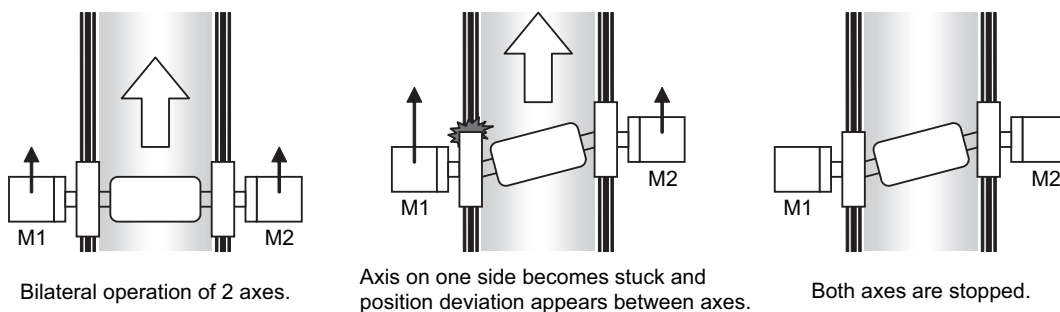

To make it easier to obtain the limit value for the deviation between axes in applications such as the above, the maximum value of the deviation is saved in the internal memory of the PCU when checking the deviation between axes.

You can read the maximum value of the deviation between axes maximum with the Memory Operation Monitor in the CX-Programmer.

The maximum value of the deviation between axes that is saved in the PCU is cleared to zero when the Memory Operation Start Bit or Memory Operation Individual Start Bit is turned ON.



Precautions for Correct Use

All of the configuration axes that are monitored must be set to the same Axis Feeding Mode. An error will occur if they are not set to the same mode.

If they are set as rotation axes (infinite lengths) (setting: 1), then the Rotation Axis Upper Limit parameter for all monitored axes must also be set to the same value.



Reference

You can monitor the deviation between axes only during linear interpolation in memory operation. For example, you can create a ladder program that monitors the deviation between electronic shaft slave axes using the Synchronous Data Link function.

10-2 Interrupt feeding

Interrupt feeding is an axis positioning function that is started during position control or speed control. Positioning is performed by moving the axis for the specified amount from the position at which the external interrupt input is received.



Precautions for Correct Use

- ◆ Interrupt feeding cannot be used for virtual axes.
- ◆ When using an OMNUC G5-series Servo Drive, the external interrupt input is allocated to latch 2 of the Servo Drive.
The allocation of latch 2 can be changed using a servo parameter object in the Servo Drive. Refer to *OMNUC G5-series AC Servomotors/Servo Drives with Built-in EtherCAT Communications User's Manual* (Cat. No. 1573) for details.

Outline of Operation

Interrupt feeding can be used for both direct operation and memory operation.

There are also three starting methods that can be used: speed control, absolute movement, and relative movement.

When you specify absolute movement or relative movement, you can also specify whether to generate an error if an interrupt input is not received within the specified amount of movement.

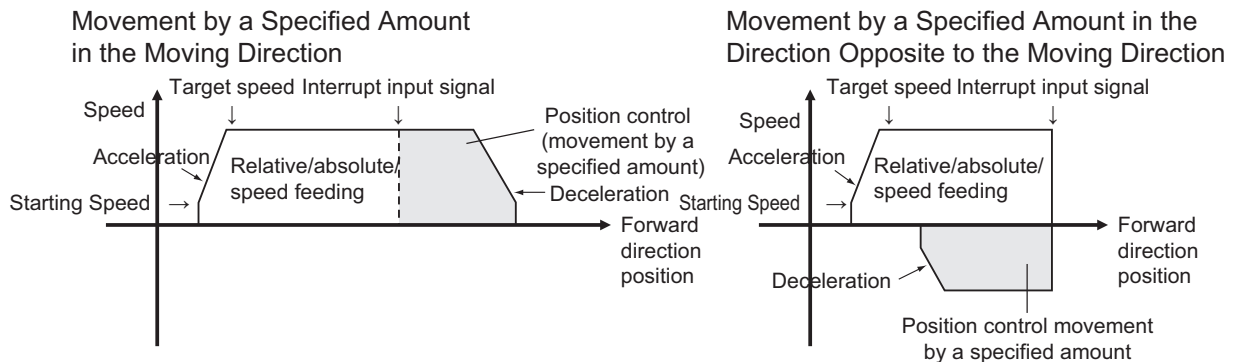

Precautions for Correct Use

- ◆ Operation when the axis reverses and moves in the direction opposite to the moving direction is controlled by the setting of the Operation at Reverse Rotation Command axis parameter.

When the Axis Feeding Mode is set to a rotation axis, you can set a value that is greater than the rotation axis upper limit that defines the maximum value per rotation. In other words, you can implement a stop after multiple rotations.

The feedback position is used for the feeding reference position.

The axis moves by the interrupt feeding amount from the feedback position where an interrupt input is received.

Movement by a Specified Amount in the Moving Direction

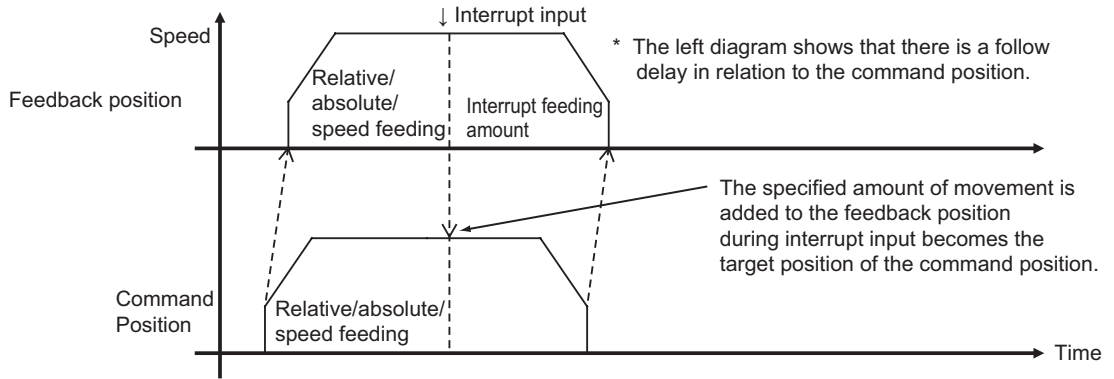

An interrupt input mask is also available to enable detecting interrupt inputs only within certain ranges.

Example: Movement by a Specified Amount in the Moving Direction

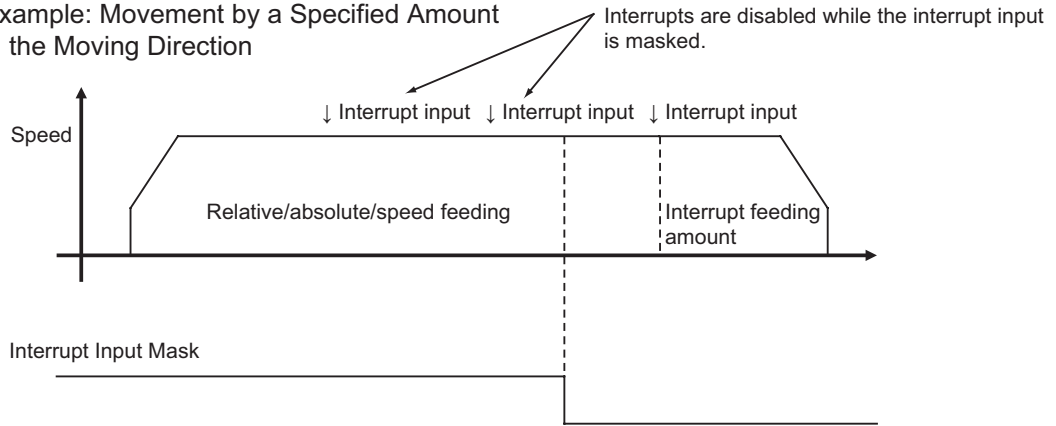

Interrupt Feeding in Direct Operation

Use the axis parameters and Operation Output Memory Area to set interrupt feeding in direct operation. For information on direct operation, refer to *Section 7 Direct Operation*.

Axis Parameter Settings

For axis parameters other than those which this section describes, refer to *6-4 Axis Parameters* on page 6-29.

1. Selecting the Interrupt Input Function under I/O Function Selection - I/O Function Settings

Set the Interrupt Input Function parameter to 0 (Use as an interrupt feeding trigger.).

For details, refer to *I/O Function Selections* on page 6-34.

2. Interrupt Feeding Settings

Parameter name	Contents of setting
Error Enable for Undetected Interrupt Input	Select whether to output an error when no interrupt input is received before positioning is completed for interrupt feeding for position control.
Interrupt Feeding Amount	Set the amount to move after an interrupt input is received.

For details, refer to *Interrupt Feeding Settings* on page 6-50.

Settings in the Operation Output Memory Area

For information on the Operation Output Memory Area, refer to *Direct Operation Command Memory Area* on page 6-91.

The setting method and starting method vary between position control and speed control as described below.

Position Control

1. Setting the Command Position

The amount of movement after an interrupt input is set in an axis parameter. The command position is set to the stopping position if no interrupt input is received.

2. Set the command speed, acceleration time, and deceleration time.

3. Starting Interrupt Feeding

First, turn ON the Interrupt Feeding Specification Bit.

The bit used to start operation depends on whether you use an absolute position or relative position for position control.

If you use an absolute position, turn ON the Absolute Movement Bit. If you use a relative position, turn ON the Relative Movement Bit.

To mask interrupt inputs during operation, turn ON the Interrupt Input Mask/Present Position Latch Enable Bit.

Interrupt inputs will not be acknowledged while the Interrupt Input Mask/ Present Position Latch Enable Bit is ON.

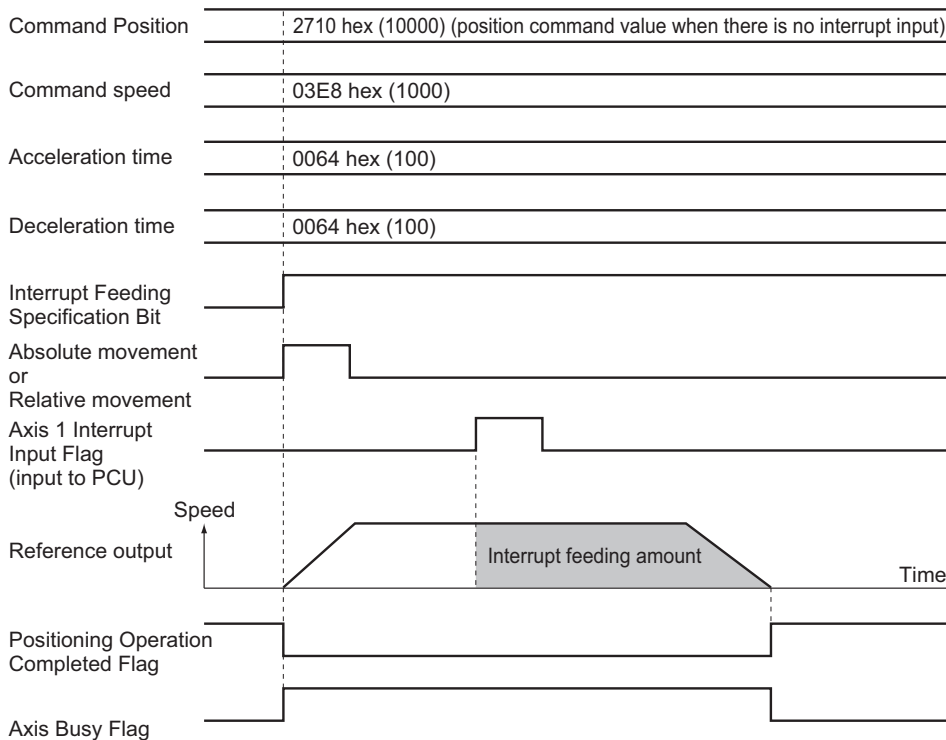

Speed Control

1. Set the command speed, acceleration time, and deceleration time.
2. Starting Interrupt Feeding

First, turn ON the Interrupt Feeding Specification Bit. Next, turn ON the Speed Control Bit. To mask interrupt inputs during operation, turn ON the Interrupt Input Mask/Present Position Latch Enable Bit. Interrupt inputs will not be acknowledged while the Interrupt Input Mask/Present Position Latch Enable Bit is ON.

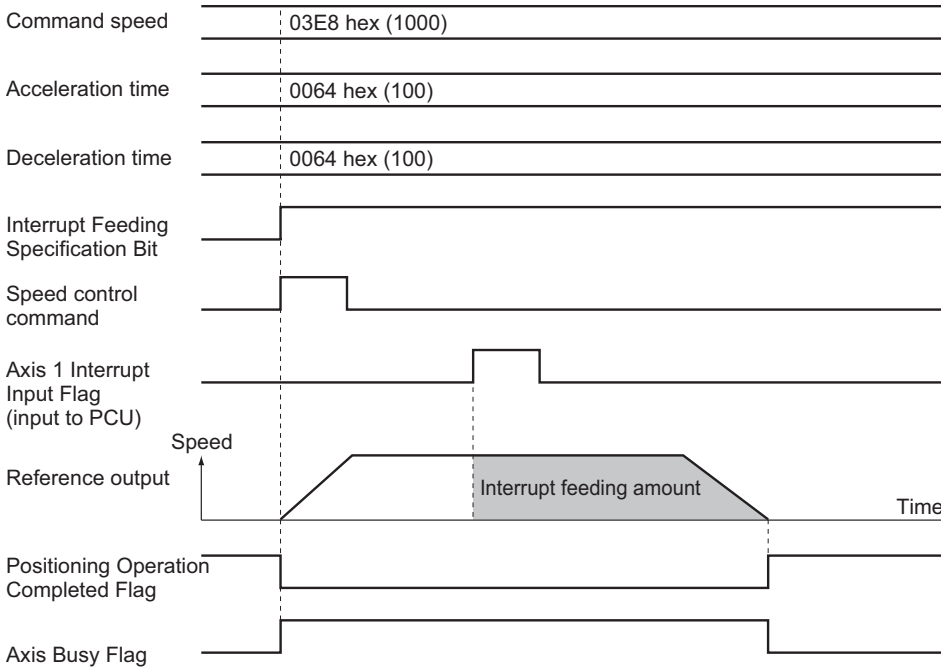

Reference

An interrupt input is not acceptable while the operations below are in progress during interrupt feeding:

- ◆ Deceleration Stop Interval for Reversing for Multi-starting of Interrupt Feeding

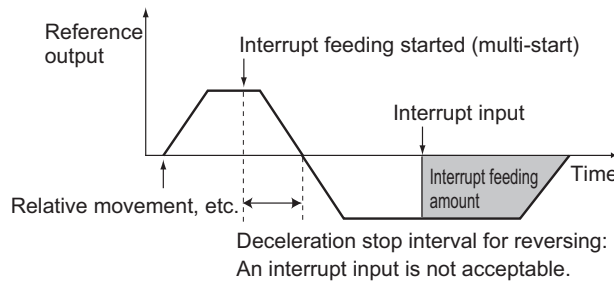

Interrupt Feeding in Memory Operation

The axis parameters and memory operation data are used to set interrupt feeding in memory operation. For information on memory operation, refer to *Section 8 Memory Operation*.

Axis Parameter Settings

For axis parameters other than those which this section describes, refer to 6-4 *Axis Parameters* on page 6-29.

1. Selecting the Interrupt Input Function under I/O Function Selection - I/O Function Settings

Set the Interrupt Input Function parameter to 0 (Use as an interrupt feeding trigger.).

For details, refer to *I/O Function Selections* on page 6-34.

Memory Operation Data Settings

For information on memory operation data, refer to 6-7 *Memory Operation Data* on page 6-147.

In the same way as for direct operation, the setting of memory operation data varies between position control and speed control.

Position Control

1. Setting the Sequence Data Command

Set the command in the sequence data to Interrupt Feeding (Positioning Operation).

For details on the setting method for sequence data, refer to *Interrupt Feeding for Positioning Operation* on page 8-36.

2. Executing Memory Operation

Execute memory operation. For information on memory operation, refer to *Section 8 Memory Operation*.

Speed Control

1. Setting the Sequence Data Command

Set the command in the sequence data to Interrupt Feeding (Speed Control).

For details on the setting method for sequence data, refer to *Interrupt Feeding for Speed Control* on page 8-37.

2. Executing Memory Operation

Execute memory operation. For information on memory operation, refer to *Section 8 Memory Operation*.

10-3 Overrides

Overrides can be used to uniformly decrease or increase all operating speeds without changing the speeds that are specified for command speed. They allow you to change the operating speed by multiplying the speed command by a multiplier.

Overrides can be used to increase or decrease the operating speed when debugging or when performing maintenance, without changing the program.

Outline of Operation

The set value of the Override parameter is used to change the speeds while Override Enable Bit in the Manual Operation Command Memory Area is ON.

$$\text{Target speed} = \text{Speed command} \times \frac{\text{Override}}{100}$$

You can set any value between 0.00% and 500.00%. If you specify 0.00%, the PCU functions in the same manner as when you set 0.01%.

Overrides are enabled during the following operations:

- ♦ Direct operation
- ♦ Memory operation
- ♦ Jogging/inching
- ♦ Origin returns

If the target speed exceeds the maximum speed that you set in the axis parameters, the target speed will be the maximum speed. Overrides are disabled during origin searches.

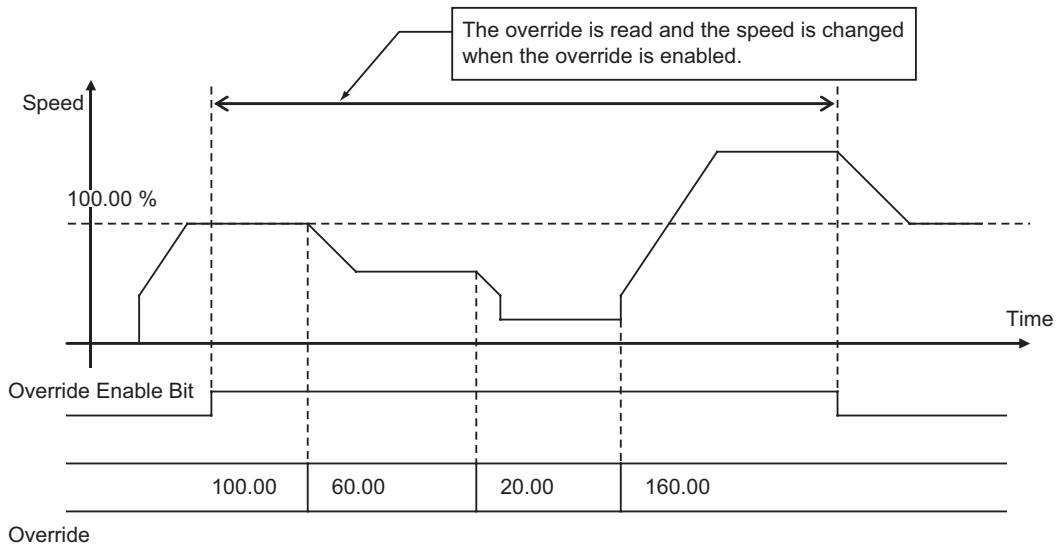

Precautions for Correct Use

- ♦ Use caution when you turn OFF the Override Enable Bit because doing so returns the override value to 100%.

Override in Operations Other than Memory Operation

The effective ranges of override in direct operation, interrupt feeding, jogging, inching, and origin returns are described below.

In direct operation, overrides function in the same manner as a command speed change during operation.

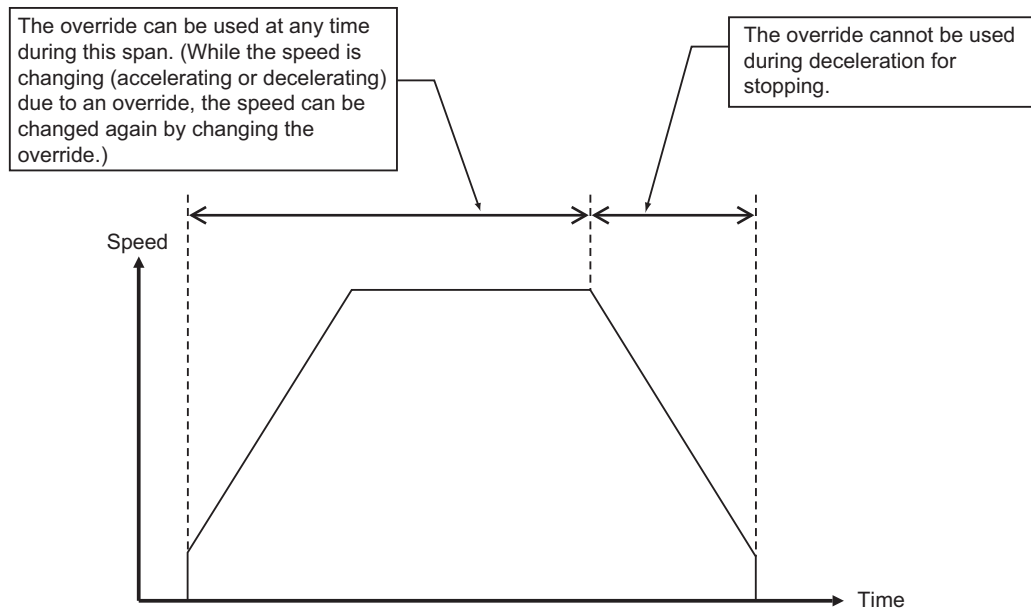

If you change the override value during operation, the axis accelerates/decelerates to the target speed that reflects the override value. If a constant acceleration/deceleration rate is specified for the Acceleration/Deceleration Time Selection, the axis will start to accelerate/decelerate toward the changed speed as soon as the override is changed.

Overrides in Memory Operation

In memory operation, the operation depends on the command and end pattern.

Differences by Command

Positioning Operation

An override can be used for each axis.

Linear Interpolation Operation

The override of the highest priority axis among the task configuration axes is used.



Reference

- ♦ The priority of the axes is configuration axis 1, configuration axis 2, configuration axis 3, configuration axis 4, in order from high to low.

Circular Interpolation

The override of the highest priority axis among the task configuration axes is used.



Reference

- ♦ The priority of the axes is configuration axis 1, configuration axis 2, configuration axis 3, configuration axis 4, in order from high to low.

Speed Control

An override can be used for each axis.

Interrupt Feeding

An override can be used for each axis.

Differences by End Pattern

In memory operation, override settings are enabled at the following times.

Individual or Automatic End Patterns

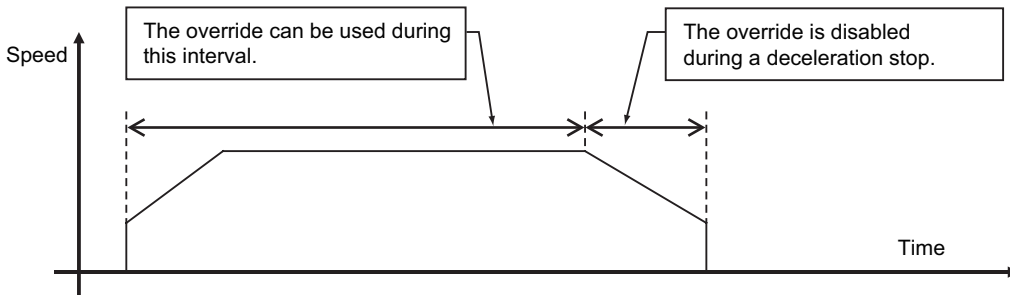

Continuous 1 End Pattern

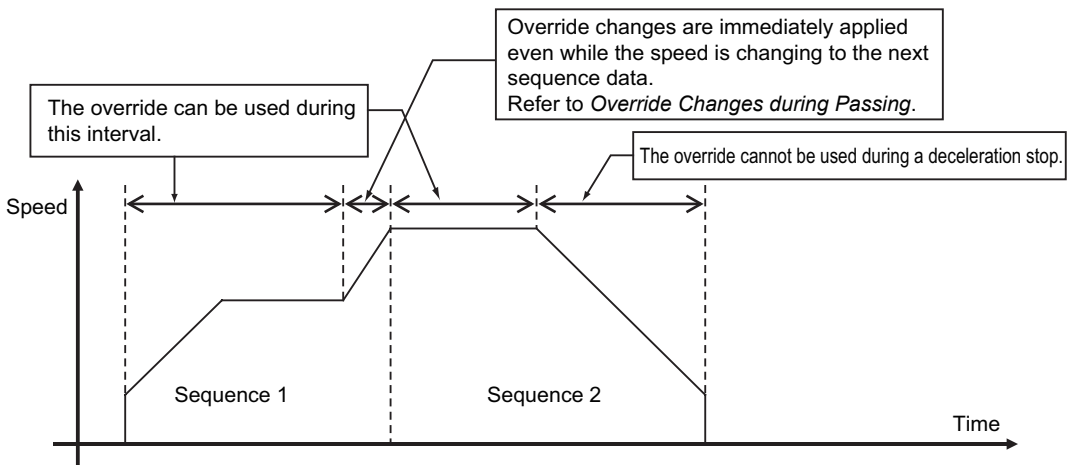

Continuous 2 End Pattern

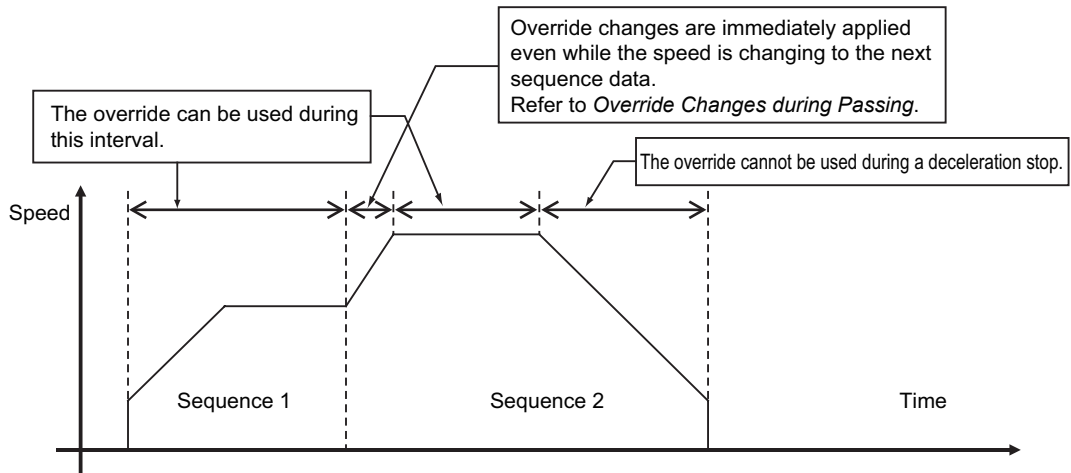

Continuous 3 End Pattern

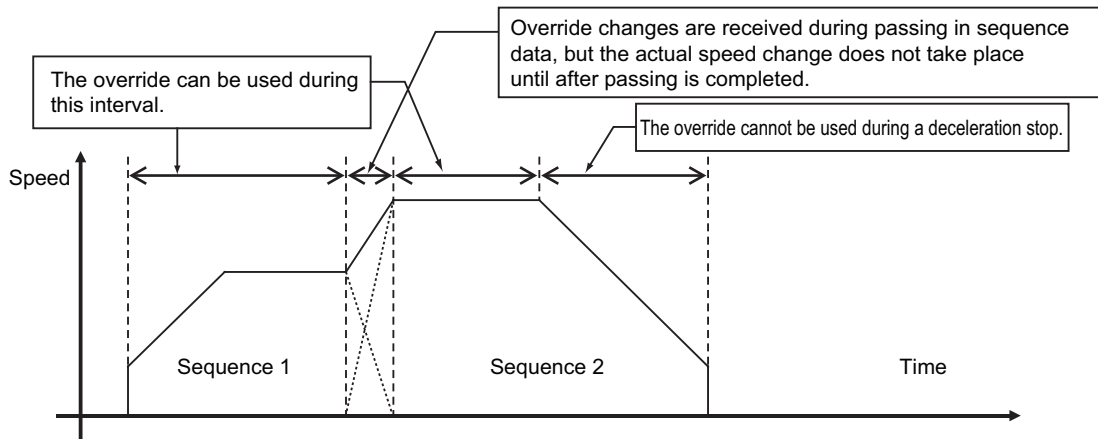

Override Changes during Passing of Continuous 1 and Continuous 2

If the end pattern is set to Continuous 1 or Continuous 2, any changes to the override value that you make during acceleration/deceleration between sequences are reflected immediately. The acceleration/deceleration behavior changes at the switching point of sequences.

This section describes how the axis moves when you change the override value to 150% while sequence 1 is changing to sequence 2 for a continuous 1 end pattern.

Acceleration/Deceleration Time Selection Set to Constant Acceleration/Deceleration Rate

If you specify a fixed acceleration/deceleration rate, the axis starts to accelerate/decelerate to the changed speed according to the acceleration/deceleration that you specified by changing the override in sequence 1.

Thereafter, when the travel amount for sequence 1 is completed, the sequence switches to sequence 2 and the axis operates according to the acceleration/ deceleration that you specified for sequence 2.

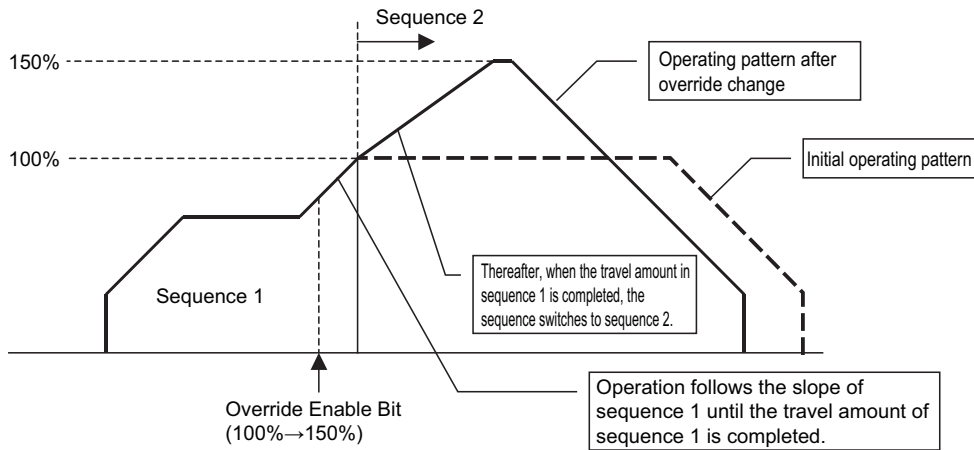

Acceleration/Deceleration Time Selection Set to Constant Acceleration/Deceleration Time

If you specify fixed acceleration/deceleration times, the axis starts to accelerate/decelerate to the changed speed as soon as the override is changed according to the acceleration/deceleration time that you specified in sequence 1.

As soon as the sequence switches, the axis starts to accelerate/decelerate according to the acceleration/deceleration time that you specified for sequence 2.

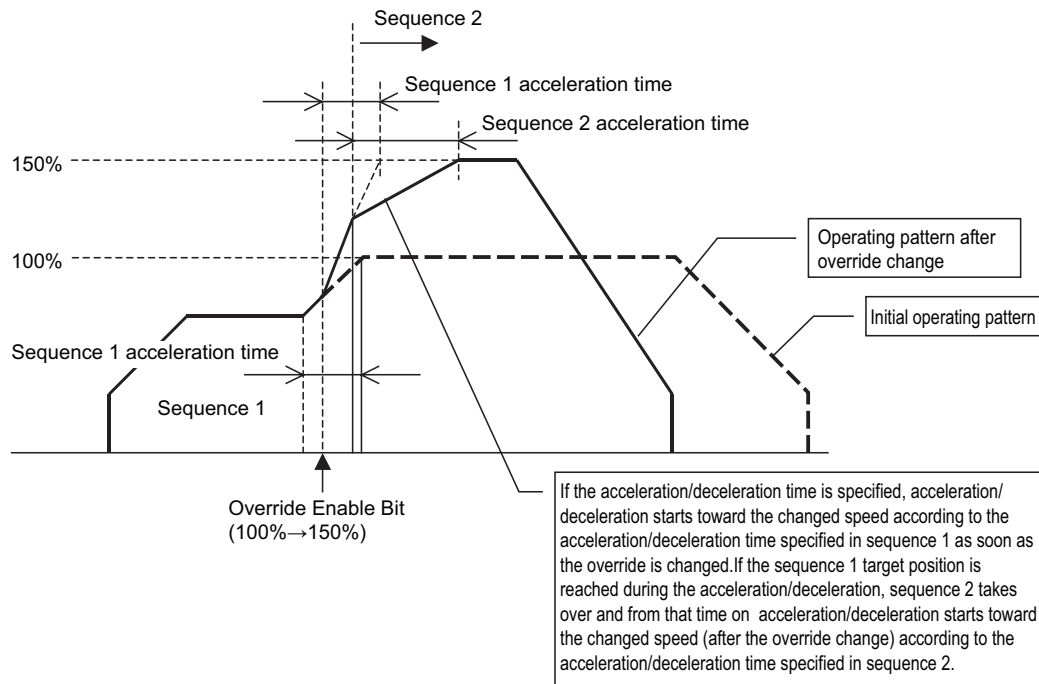

Memory Area Words and Bits That Are Used

Use the Manual Operation Command Memory Area to set the override function for both direct operation and memory operation. Use the Override setting and the Override Enable Bit in the Manual Operation Command Memory Area. There is an Override setting and an Override Enable Bit for each axis. For details, refer to *Manual Operation Command Memory Area* on *Manual Operation Command Memory Area* on page 6-89.

10-4 Torque Limits

The torque limits from the PCU to the Servo Drive can be enabled and disabled.

Turning ON/ OFF the Forward Torque Limit Bit and Reverse Torque Limit Bit in the Manual Operation Command Memory Area turns ON/OFF the torque limit outputs in the Servo Drive.



Reference

- Even when the torque limit is being automatically controlled for an origin search, the Torque Limit Bits can be used to enable and disable the torque. The status of the Torque Limit Bits, however, will be ORed with the status for automatic control to determine whether the torque limit is applied.

Normal Torque Limits

For torque control during normal position, such as in controlling pressing, the Torque Limit Bits can be manipulated from the ladder program to enable and disable torque control.

Automatic Control during Origin Searches

If you set the Origin Search Operation Mode to B (Proximity Reverse Turn/Holding Time), C (Proximity Reverse Turn/Holding Origin Input) or D (No Origin Proximity Input/Holding Origin Input), the torque limit is controlled automatically.

The torque status will be maintained after the completion of automatic torque limit control for origin returns (i.e., after the origin is defined). For details, refer to *Proximity Reverse Turn and Holding Time (Setting: 11)* on page 5-36, *Proximity Reverse Turn and Holding Origin Input (Setting: 12)* on page 5-37, and *No Origin Proximity Input and Holding Origin Input (Setting: 13)* on page 5-38.

Torque limits are released for operation in the direction opposite to the origin input detection direction. For example, if the origin compensation is in the direction opposite to the origin input detection direction, the torque limit will be released when origin compensation is started.



Precautions for Correct Use

When using axis parameters (e.g. simple backup function) from a unit version 1.1 or earlier PCU, the Maximum Torque axis parameter is set to 0. Be sure to configure the maximum torque whenever you use a method in which the torque limit data is configured using the Memory Area/Synchronous Data Link. Otherwise you cannot obtain the correct torque.

Updating Torque Limit Data Directly from an Allocated Memory Area

The CJ1W-NC□81/□82 PCU with unit version 1.3 or later has the function to update the forward and reverse torque limit data directly from an allocated memory area.

To use this function, you must meet all of the following.

- ♦ OMNUC G5-series Servo Drive version 2.0 or later
- ♦ The PDO setting that corresponds to the torque limit data refresh function is selected in Support Software.
Refer to *Selecting PDO Mappings When Using the PCU in Conjunction with a G5-series Servo Drive* on page 2-17 for information on selecting PDO mappings.
Make sure that the positive torque limit value (60E0h) and reverse torque limit value (60E1h) in the data list are mapped to PDO communications. Without this mapping, this function is disabled.
- ♦ The OMNUC G5-series Servo Drive's torque limit selection setting (3521 hex) is 5.

Relationship between Forward/Reverse Torque Limit Command Bits and Torque Limit Values

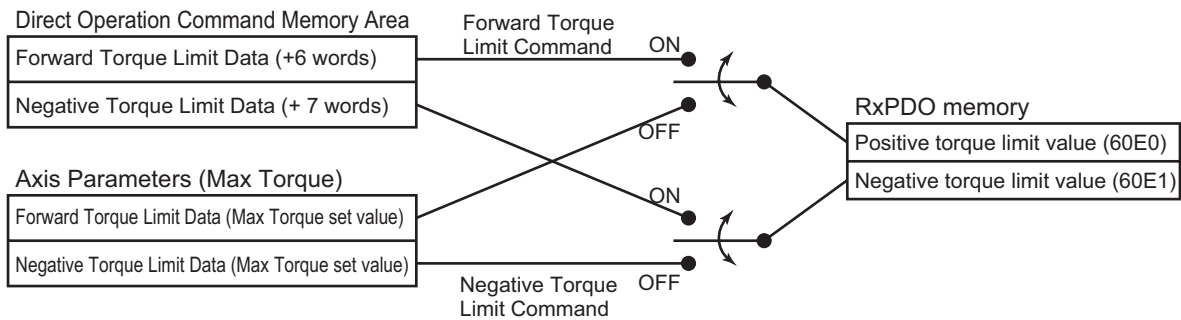

Relationship with Synchronous Feeding Torque Options

For details of the synchronous feeding torque option settings, refer to 11-5 *Synchronous Feeding Position* on page 11-12 and 11-6 *Synchronous Feeding Velocity* on page 11-25.

During synchronous feeding command (position/speed), you can use the synchronous data link to command the torque limits.

If both the Forward (Reverse) Torque Limit Command Bits in Manual Operation Command Memory Area and the Torque Limit Bits of a synchronous feeding command turn ON simultaneously, the Torque Limit Bits in the Direct Operation Command Memory Area takes precedence.

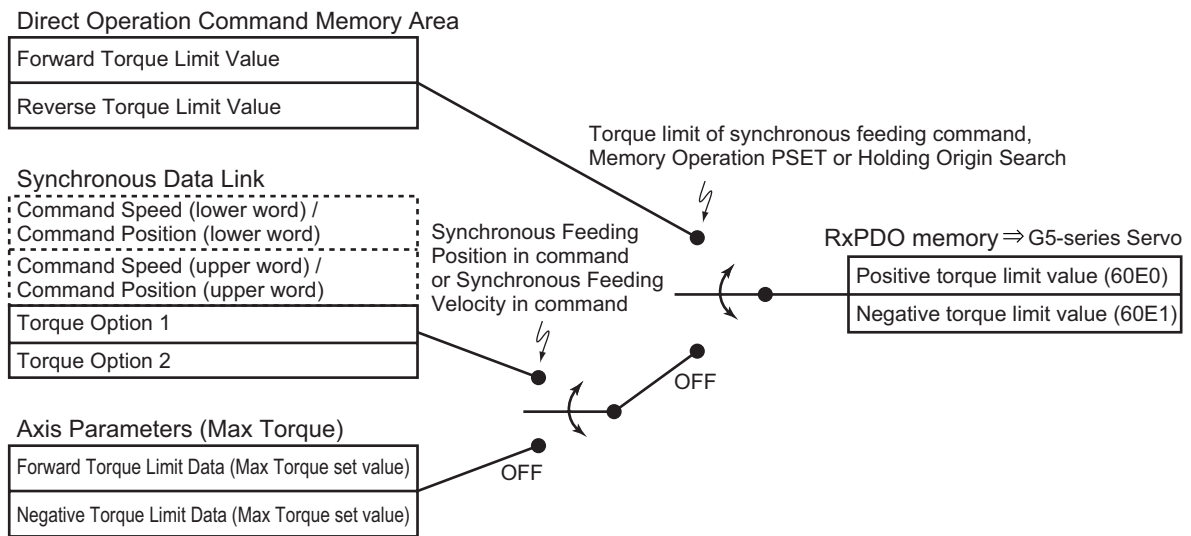

Precautions for Correct Use

Updating the torque limit data directly from the operation Memory Area/Synchronous Data Link Area requires that the Maximum Torque axis parameter be correctly configured. Set in advance the torque limit data in the Direct Operation Command Memory Area to the maximum output torque value of the motor or less. Setting a value larger than the maximum output torque of the motor prevents correct torque generation. Also, do not set the maximum torque to too small a value since the torque cannot be higher than your configured value. This should be carefully followed especially when you use vertical axes.



Reference

- ♦ If you prefer to use an OMNUC G5-series Servo Drive version 2 or later in the same manner as Servo Drive version 1.□, set the torque limit switching mode (3521 hex) to 6. Then, set the Maximum Torque axis parameter to 300.0% (default setting). This setting does not cause the torque limit data from being updated from the memory area.
- ♦ If you are updating the torque limit data from the Direct Operation Memory Area or the Synchronous Data Link, set the torque limit switching mode (3521 hex) of the OMNUC G5-series Servo Drive version 2.0 or later to 5. Also, set in advance an appropriate torque limit data in the Direct Operation Command Memory Area in preparation for Torque Limit Automatic Control (Holding Origin Search) and Memory Operation (using PSET/PRSET).

Torque Limit Operation

The torque limit switching function provided by the OMNUC G5-series Servo Drive is used to switch the torque limits with the Forward Torque Limit Bit and Reverse Torque Limit Bit and with automatic torque limit control during origin searches.

The Torque Limit Selection (slave parameter index: 3521 hex) can be used to switch the enabled torque limit for the OMNUC G5- series Servo Drive as shown in the following tables.

Refer to the *OMNUC G5-series AC Servomotors/Servo Drives with Built-in EtherCAT Communications User's Manual* (Cat. No. I573-E1) for information on the setting for the OMNUC G5-series Servo Drive version 1.□.

The settings of the OMNUC G5-series Servo Drive version 2.0 or later are as follows.

Torque Limit Selection set value	Forward Torque Limit Bit		Reverse Torque Limit Bit	
	ON	OFF	ON	OFF
0, 1	3013 hex			
2	3013 hex		3013 hex	
3	3522 hex	3013 hex	3522 hex	3013 hex
4	60E0 hex or 3013 hex ^{*1}		60E0 hex or 3522 hex ^{*2}	
5	60E0 hex or 3013 hex ^{*1}	3013 hex	60E0 hex or 3522 hex ^{*2}	3522 hex
6	3525 hex	60E0 hex or 3013 hex ^{*1}	3526 hex	60E0 hex or 3522 hex ^{*2}
7	3013 hex	3525 hex	3522 hex	3526 hex

*1. 60E0 hex or 3013 hex: Whichever has a smaller value, is applicable.

*2. 60E1 hex or 3522 hex: Whichever has a smaller value, is applicable.

Index	Name	Description
3521 hex	Torque Limit Selection	Set the torque limits according to objects and input signals.
3013 hex	Torque Limit 1	Sets Motor Output Torque Limit 1.
3522 hex	Torque Limit 2	Sets Motor Output Torque Limit 2.
3525 hex	Torque Limit 3	Sets Motor Output Torque Limit 3.
3526 hex	Torque Limit 4	Sets Motor Output Torque Limit 4.
60E0 hex	Forward Torque Limit	Set the forward output torque limit of the motor.
60E1 hex	Reverse Torque Limit	Set the reverse output torque limit of the motor.

Note 1: Refer to the *OMNUC G5-series AC Servomotors/Servo Drives with Built-in EtherCAT Communications User's Manual* (Cat. No. I573) for details on the torque limit function of the Servo Drive.

Note 2: For automatic torque limit control during origin searches, the torque limit for the bit that is ON will be enabled. Set the torque limits so that the operation when the torque limit is enabled is in the pressing direction.

10-5 Teaching

Teaching refers to the process of moving the axis to a specified position and then saving the present position of the axis as position data.

The position data that is taught is saved in the PCU as memory operation data.

Outline of Operation

Teaching is performed separately for each task.

When the Teaching Bit in the Memory Operation Command Memory Area turns ON, the present positions of all configuration axes in the task are saved in the specified sequence.

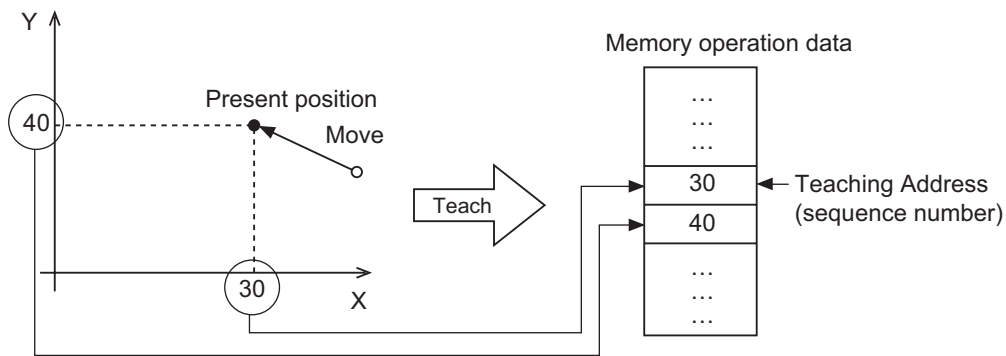

Precautions for Correct Use

- Although you can execute teaching even if the origin is not defined, the position data that is saved may be different once the origin is defined.
- Any position data you saved in the PCU using teaching is lost if you turn OFF the PLC power supply or restart the PCU. You must save the taught position data to retain it. For more information on saving the position data, refer to 9-7 *Saving Data* on page 9-56.
- To move the axis to a position that is to be taught, set the Position Specification parameter for absolute positions. If you use relative positions, the axis may move to a position which is different from the taught position.

Teaching Procedure

Use the following procedure to execute teaching.

1. Setting the Teaching Object in the Memory Operation Parameters

Select whether to use the command position or feedback position for the target position data for teaching.

2. Moving the Axis to the Position To Be Taught

Move each axis to the position that you want to teach by using jogging or other functions.

3. Setting the Teaching Address in the Memory Operation Command Memory Area

Set the sequence number for which you want to store the position data that is taught.

4. Executing Teaching

Turn ON the Teaching Bit to execute teaching.

Timing Chart

The following chart shows the timing of position data to be stored for sequence 2.

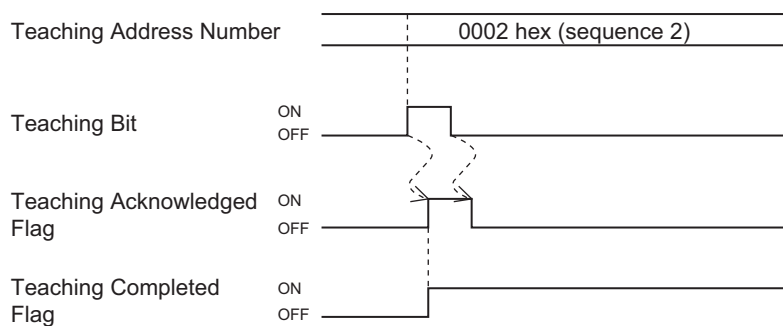

10-6 Positioning Completion

This function determines when positioning has been completed by monitoring the feedback position of the Servo Drive.

Operating Procedures

Use the following procedure to use the positioning completion function.

1. Setting of the Positioning Completion Width in the Axis Parameters

Set the positioning completed width.

2. Setting of the Positioning Monitoring Time in the Axis Parameters

Positioning completion monitoring is enabled if you set the Positioning Monitoring Time axis parameter to any value except 0. With the Positioning Monitoring Time and Positioning Completed Width parameter settings, you can use the positioning completion function for positioning operations during direct operation.

3. Setting of the Positioning Completion Input Monitor Valid Setting in Sequence Data

When performing memory operation, in addition to the above settings, use the Positioning Completed Input Monitor Valid setting in to specify whether to perform a positioning completion check.

Set whether to perform positioning completion checks for each sequence.



Reference

During direction operation, the Positioning Operation Completed Flag in the Command Status in the Axis Status Memory Area will turn ON and OFF for the settings in steps 1 and 2, above.

Operating Method

During memory operation, you can set whether to perform a positioning completion check in the sequence operation. To perform the operation as quickly as possible, start the next operation without waiting for the positioning completion check. But to confirm completion of positioning before the next operation starts, perform a positioning completion check.

The positioning completion check is not performed when stopping for the following operations:

- ♦ Deceleration stop
- ♦ Stopping due to an error
- ♦ Stopping for reversing during an origin search
- ♦ Stopping for reversing due to multi-starting
- ♦ Stopping for reversing for interrupt feeding control



Precautions for Correct Use

If you set the Positioning Monitoring Time axis parameter to 0, arrival will not be monitored for the Servo Drive feedback position. To monitor when the feedback position from the Servo Drive for the command position arrives within the positioning completed width in order to determine when the positioning operation is completed, set the Positioning Monitoring Time axis parameter to a value other than 0.



Reference

- ♦ You can also combine this function with the Positioning Monitoring Time parameter in the IO Function Selection in the axis parameters to output an error when positioning is not completed within the monitoring time after the output of a positioning command.
- ♦ If you set the Positioning Monitoring Time axis parameter to 0, arrival will not be monitored for the Servo Drive feedback position. If you use the positioning completion function for the feedback position from the Servo Drive, set the Positioning Monitoring Time axis parameter to a value other than 0.

When the Positioning Monitoring Time Axis Parameter Is Not Set to 0

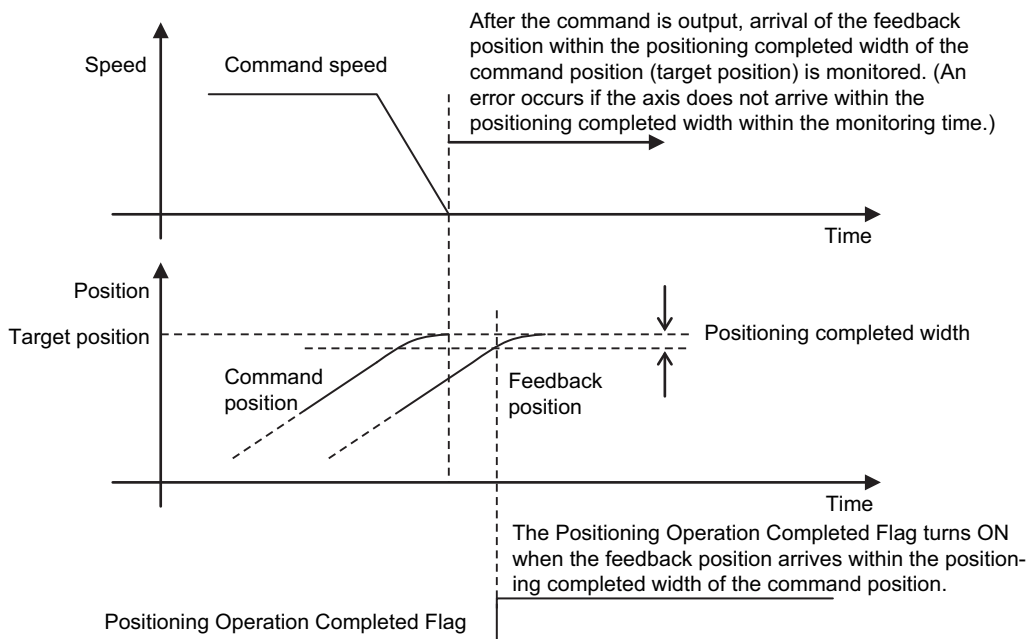

10-6 Positioning Completion

When the Positioning Monitoring Time Axis Parameter Is Set to 0 or Positioning Completion Monitoring Is Not Used

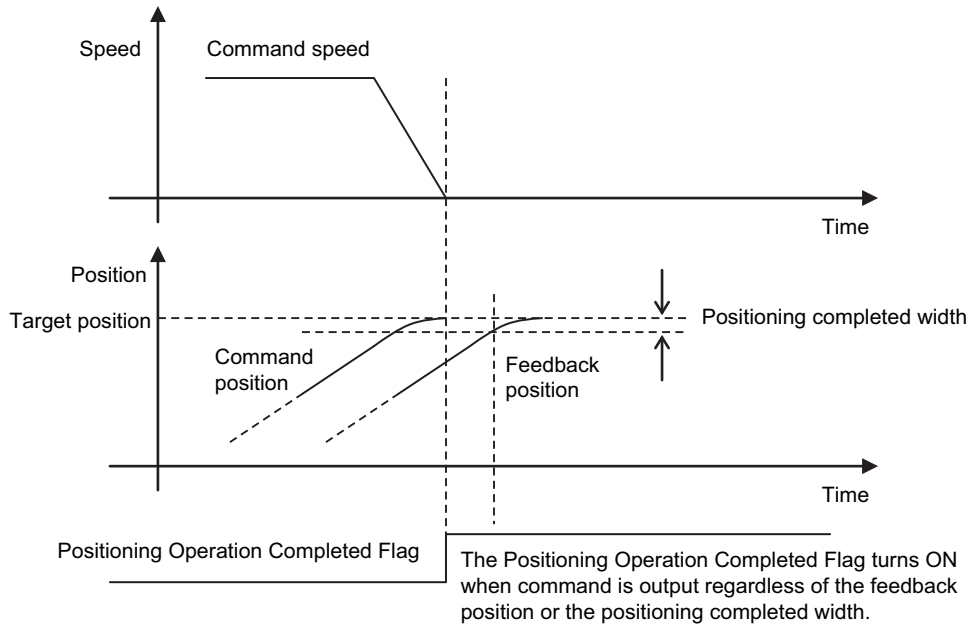

10-7 Present Position Latch

The present position latch function stores in the PCU the current Servo Drive position data when an external interrupt input is received.

The feedback position is latched as the position data.



Precautions for Correct Use

When using an OMNUC G5-series Servo Drive, the external interrupt input is allocated to latch 2 of the Servo Drive.

The allocation of latch 2 can be changed using a servo parameter object in the Servo Drive. Refer to *OMNUC G5-series AC Servomotors/Servo Drives with Built-in EtherCAT Communications User's Manual* (Cat. No. I573) for details.

Procedure

Use the following procedure to set the present position latch function.

1. Setting the Interrupt Input Function parameter in the I/O Function Settings

Set the Interrupt Input Function parameter to use the interrupt input signal as a present position latch signal for each axis.

2. Turning ON the Interrupt Input Mask/Present Position Latch Enable Bit

Turn ON the Interrupt Input Mask Enable/Present Position Latch Enable Bit in the Direct Operation Command Memory Area.

Latching is not possible if the Interrupt Input Mask Enable/Present Position Latch Enable Bit is OFF.

3. Turning ON the Interrupt Input

The position data is stored in the PCU when the interrupt input turns ON. When the present position has been latched, the Latch Completed Flag in the Axis Status Memory Area will turn ON.

4. Reading Data

To read the latched position data, use an IORD(222) instruction. The data can also be read cyclically by using the Expanded Monitor function. For the setting procedure for an expanded monitor, refer to *Expanded Monitor Settings* on page 6-59, *Axis Status Memory Area* on page 6-100.

The data addresses for the IORD(222) instruction are as follows:

Data name	Parameter Type	Unit address
Axis 1 present position latch data	1201 hex	0000 hex (lower word)
		0001 hex (upper word)
Axis 2 present position latch data	1202 hex	0000 hex (lower word)
		0001 hex (upper word)
Axis 3 present position latch data	1203 hex	0000 hex (lower word)
		0001 hex (upper word)

10-7 Present Position Latch

Data name	Parameter Type	Unit address
Axis 4 present position latch data	1204 hex	0000 hex (lower word)
		0001 hex (upper word)
Axis 5 present position latch data	1205 hex	0000 hex (lower word)
		0001 hex (upper word)
Axis 6 present position latch data	1206 hex	0000 hex (lower word)
		0001 hex (upper word)
Axis 7 present position latch data	1207 hex	0000 hex (lower word)
		0001 hex (upper word)
Axis 8 present position latch data	1208 hex	0000 hex (lower word)
		0001 hex (upper word)
Axis 9 present position latch data	1209 hex	0000 hex (lower word)
		0001 hex (upper word)
Axis 10 present position latch data	120A hex	0000 hex (lower word)
		0001 hex (upper word)
Axis 11 present position latch data	120B hex	0000 hex (lower word)
		0001 hex (upper word)
Axis 12 present position latch data	120C hex	0000 hex (lower word)
		0001 hex (upper word)
Axis 13 present position latch data	120D hex	0000 hex (lower word)
		0001 hex (upper word)
Axis 14 present position latch data	120E hex	0000 hex (lower word)
		0001 hex (upper word)
Axis 15 present position latch data	120F hex	0000 hex (lower word)
		0001 hex (upper word)
Axis 16 present position latch data	1210 hex	0000 hex (lower word)
		0001 hex (upper word)

For information on reading data with the IORD(222) instruction, refer to *9-5 Reading Data with IORD(222)* on page 9-50.

For the storage area for monitored values, refer to *Expanded Monitor Settings* on page 6-59 for allocation of Expanded Area, and to *Axis Status Memory Area* on page 6-100.

5. Resetting the Latch Completed Flag

You cannot execute the next latch unless you reset the current latch.

To reset the Latch Completed Flag, turn ON Latch Completed Flag Clear Bit in the Direct Operation Command Memory Area. Turning ON Latch Completed Flag Clear Bit also clears the latch data to 0.

Timing Chart

The following chart shows the chart when you use the present position latch function.

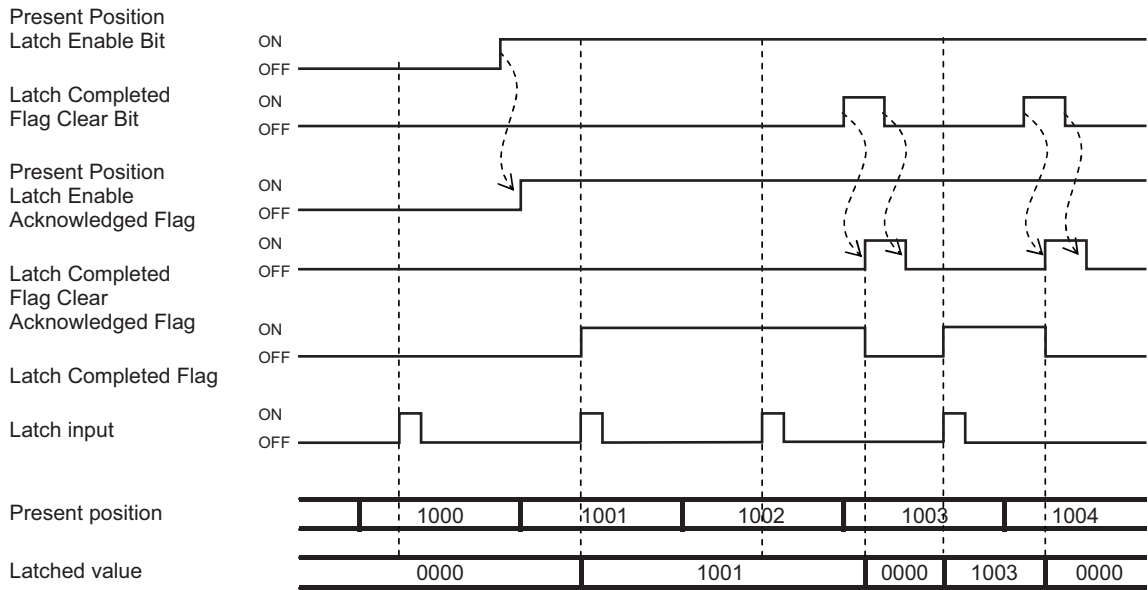

When the Interrupt Input Mask/ Present Position Latch Enable Bit is OFF, the present position is not latched even if there is a latch input.

If the present position latch is executed, Latch Completed Flag turns ON. The next present position latch will not be executed until the Latch Completed Flag is cleared.

10-8 Origin Position Latch

The Origin Position Latch function is available with the CJ1W-NC□81/-NC□82 PCUs (unit version 1.3 or later).

The Origin Position Latch function stores in the PCU the position data when an origin input signal is received. The position data to be stored is the feedback position. The origin input signal depends on the Origin Input Signal Selection axis parameter.

There are two ways to enable latching: turning ON the Origin Position Latch Enable Bit in the Direct Operation Command Memory Area and automatically enabling latching during an origin search.

If you enable latching during an origin search, the latch data is saved according to the counter value before the origin search, instead of the counter value after the origin is defined. If the Origin Position Latch flag in the Direct Operation Command Memory Area and the origin search function is activated together, a multi-starting error occurs.



Precautions for Correct Use

When using an OMNUC G5-series Servo Drive, the external origin input is allocated to latch 1 of the Servo Drive.

The allocation of latch 1 can be changed using a servo parameter object in the Servo Drive. Refer to *OMNUC G5-series AC Servomotors/Servo Drives with Built-in EtherCAT Communications User's Manual* (Cat. No. I573) for details.

Operating Procedures for Direct Operation Command Memory Area

Use the following procedure to set the Origin Position Latch function from the Direct Operation Command Memory Area.

1. Setting the Origin Input Signal Selection parameter in the I/O Function Settings

For each axis, use the Origin Input Signal Selection parameter to select whether to use the Z-phase input as the origin input or to use an external origin input.

2. Turning ON the Origin Position Latch Enable Bit

Latching is not possible if the Origin Position Latch Enable Bit is OFF.

3. Turning ON the Origin Input

The position data is stored in the PCU when the origin input turns ON.

When the origin position has been latched, the Origin Position Latch Completed Flag in the Axis Status Memory Area will turn ON.

4. Reading Data

To read the latched position data, use an IORD(222) instruction.

The data can also be read cyclically by using the Expanded Monitor function.

For the setting procedure for an expanded monitor, refer to *Expanded Monitor Settings* on page 6-59, *Axis Status Memory Area* on page 6-100.

The data addresses for the IORD(222) instruction are as follows:

Data name	Parameter type	Unit address
Axis 1 origin position latch data	1301 hex	0000 hex (lower word)
		0001 hex (upper word)
Axis 2 origin position latch data	1302 hex	0000 hex (lower word)
		0001 hex (upper word)
Axis 3 origin position latch data	1303 hex	0000 hex (lower word)
		0001 hex (upper word)
Axis 4 origin position latch data	1304 hex	0000 hex (lower word)
		0001 hex (upper word)
Axis 5 origin position latch data	1305 hex	0000 hex (lower word)
		0001 hex (upper word)
Axis 6 origin position latch data	1306 hex	0000 hex (lower word)
		0001 hex (upper word)
Axis 7 origin position latch data	1307 hex	0000 hex (lower word)
		0001 hex (upper word)
Axis 8 origin position latch data	1308 hex	0000 hex (lower word)
		0001 hex (upper word)
Axis 9 origin position latch data	1309 hex	0000 hex (lower word)
		0001 hex (upper word)
Axis 10 origin position latch data	130A hex	0000 hex (lower word)
		0001 hex (upper word)
Axis 11 origin position latch data	130B hex	0000 hex (lower word)
		0001 hex (upper word)
Axis 12 origin position latch data	130C hex	0000 hex (lower word)
		0001 hex (upper word)
Axis 13 origin position latch data	130D hex	0000 hex (lower word)
		0001 hex (upper word)
Axis 14 origin position latch data	130E hex	0000 hex (lower word)
		0001 hex (upper word)
Axis 15 origin position latch data	130F hex	0000 hex (lower word)
		0001 hex (upper word)
Axis 16 origin position latch data	1310 hex	0000 hex (lower word)
		0001 hex (upper word)

For information on reading data with the IORD(222) instruction, refer to *9-5 Reading Data with IORD(222)* on page 9-50.

For the storage area for monitored values, refer to *Expanded Monitor Settings* on page 6-59 for allocation of Expanded Area, and to *Axis Status Memory Area* on page 6-100.

5. Resetting the Origin Position Latch Completed Flag

You cannot execute the next latch unless you reset the current latch.

To reset the Origin Position Latch Completed Flag, turn ON Origin Position Latch Completed Flag Clear Bit in the Direct Operation Command Memory Area. Turning ON Origin Position Latch Completed Flag Clear Bit also clears the latch data to 0.

Timing Chart

The following chart shows the chart when you use the Origin Position Latch function from the Direct Operation Command Memory Area.

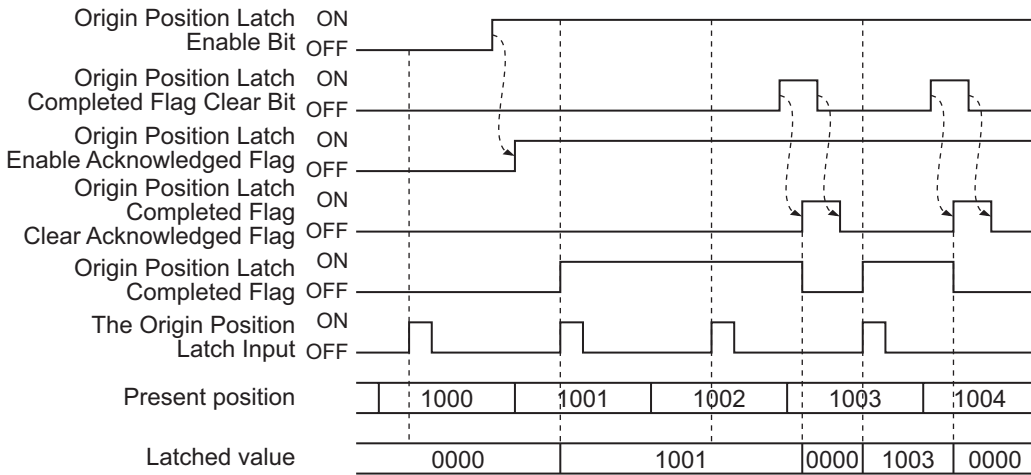

When the Interrupt Input Mask/ Origin Position Latch Enable Bit is OFF, the present position is not latched even if there is a latch input.

If the present position latch is executed, Latch Completed Flag turns ON. The next present position latch will not be executed until the Latch Completed Flag is cleared.

Operating Procedures for Origin Search

Use the following procedure to set the Origin Position Latch function from the Origin Search Bit.

1. Setting the Origin Input Signal Selection parameter in the I/O Function Settings

For each axis, use the Origin Input Signal Selection parameter to select whether to use the Z-phase input as the origin input or to use an external origin input.

2. Starting Origin Search

Turn ON the Origin Search Command Bit in the Manual Operation Command Memory Area. The Origin Position Latch Completed Flag is reset automatically and the Origin Position Latch function is enabled.

3. Turning ON the Origin Input

The position data is stored in the PCU when the origin input turns ON. When the origin position has been latched, the Origin Position Latch Completed Flag in the Axis Status Memory Area will turn ON.

4. Reading Data

To read the latched position data, use an IORD(222) instruction.

The data can also be read cyclically by using the Expanded Monitor function.

For the setting procedure for an expanded monitor, refer to *Expanded Monitor Settings* on page 6-59, *Axis Status Memory Area* on page 6-100.

For the data addresses for the IORD(222) instruction, refer to *Operating Procedures for Direct Operation Command Memory Area* on page 10-31.

Timing Chart

The following chart shows the chart when you use the Origin Position Latch function from the Origin Search Command Bit.

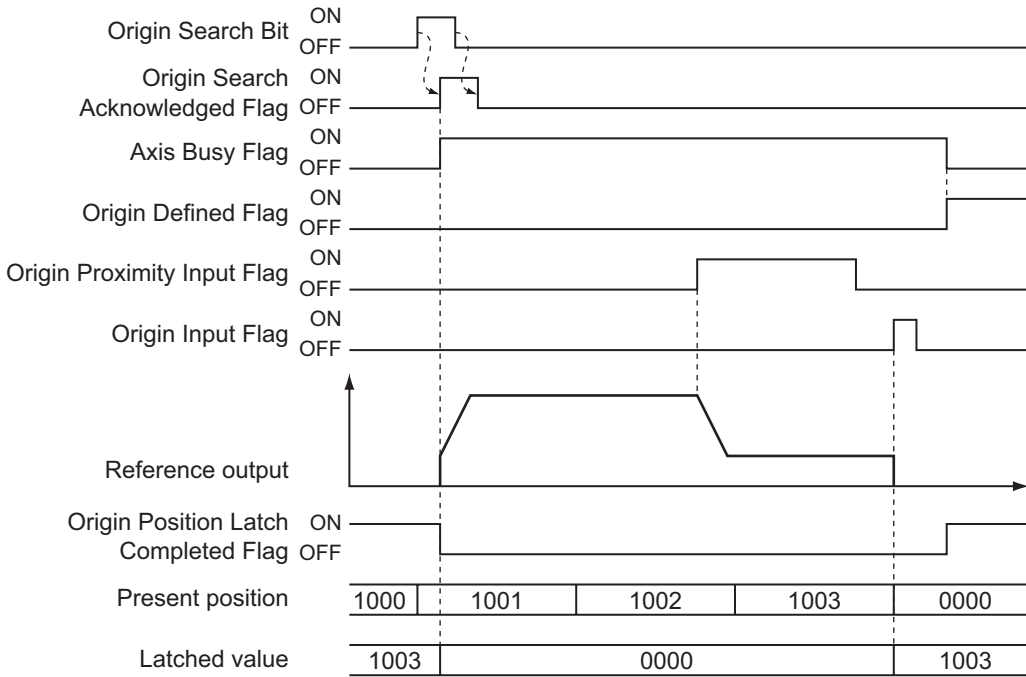

11

Synchronous Data Link

This section describes the outline and the procedure for using the Synchronous Data Link function.

11-1 Outline of Synchronous Data Link	11-1
11-2 Synchronous Data Link	11-5
11-3 Synchronous Unit Stop Function	11-7
11-4 Errors Detected in Synchronous Units	11-10
11-5 Synchronous Feeding Position	11-12
11-6 Synchronous Feeding Velocity	11-25
11-7 Synchronous Feeding Torque	11-31

11-1 Outline of Synchronous Data Link

To use the Synchronous Data Link function, use a combination of the CJ1W-NC□82 PCU (unit version 1.3 or later) with the CJ2H-CPU (unit version 1.4 or later).

The Synchronous Data link function allows data exchange between the CPU and PCUs at regular intervals.

This section describes the outline the procedure for using the Synchronous Data Link function.

About Synchronous Data Link

The function synchronizes data exchange between the CPU Unit and multiple CPU Bus Units by the synchronous signal transmitted by the CPU Unit at regular intervals.

The CJ1W-NC□82 PCU can establish a synchronous data link with the CJ1W-NC□□4 PCU in a mixed system configuration.

The following is differences between the CJ1W-NC□□4 and the CJ1W-NC□82.

- ♦ The CJ1W-NC□□4 synchronizes the start timing of internal processing according to the synchronization signal transmitted from the CPU Unit at regular intervals.
- ♦ The CJ1W-NC□82, however, does not support this function and therefore it does not synchronize the start timing of internal processing.

The CJ1W-NC□82 PCU stops the ongoing internal control process according to the synchronization signal transmitted from the CPU Unit at fixed intervals and executes the Synchronous Data link Function.

A PCU supporting the Synchronous Data Link function is referred to as "synchronous unit" hereafter.



Precautions for Correct Use

- ♦ To use the Synchronous Data Link function, use a combination of the CJ1W-NC□82 PCU (unit version 1.3 or later) with the CJ2H-CPU Unit (unit version 1.4 or later). If the unit version of the CJ2H-CPU Unit is earlier than 1.3, an error occurs and PCU does not start up.
- ♦ Make sure that the PCU's internal control cycle (A) is the same or shorter than the CPU Unit's synchronous control cycle (B). The setting range for B is from 0.5 ms to 10 ms inclusive.
- ♦ The Input Data Clear Mode for Communications Error setting does not apply to the Synchronous Data Link function. Input data will be retained if a communications error occurs.

Setting Procedure

The Synchronous Data Link function works with synchronous units connected on a CPU Rack. It works after registering synchronous units in the PLC system settings of the CPU Unit and enabling Synchronous Control in the Inter-unit Synchronous Settings.

The following is the procedure to execute the Synchronous Data Link function using the CJ1W-NC□82.

1. Registering the PLC System Settings

Using CX-Programmer, select the Use Synchronous Operation in the Synchronous Unit Operation Settings window.

Select the Synchronous Cycle Time, insert the PCU to register as a Synchronous Unit, and register the Input Size and Output Size of the Synchronous Data Link Area.

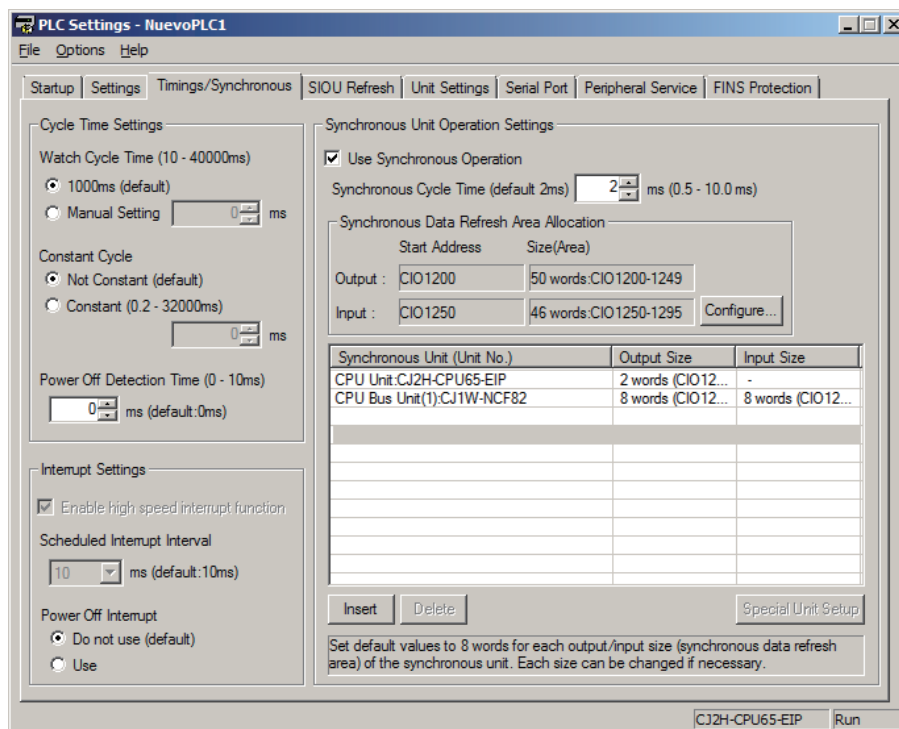

2. Setting the PCU Synchronous Control Parameters

Select the Special Unit Setup button in the Synchronous Unit Operation Settings window and, in the window that appears, allocate the output area and input area of the PCU.

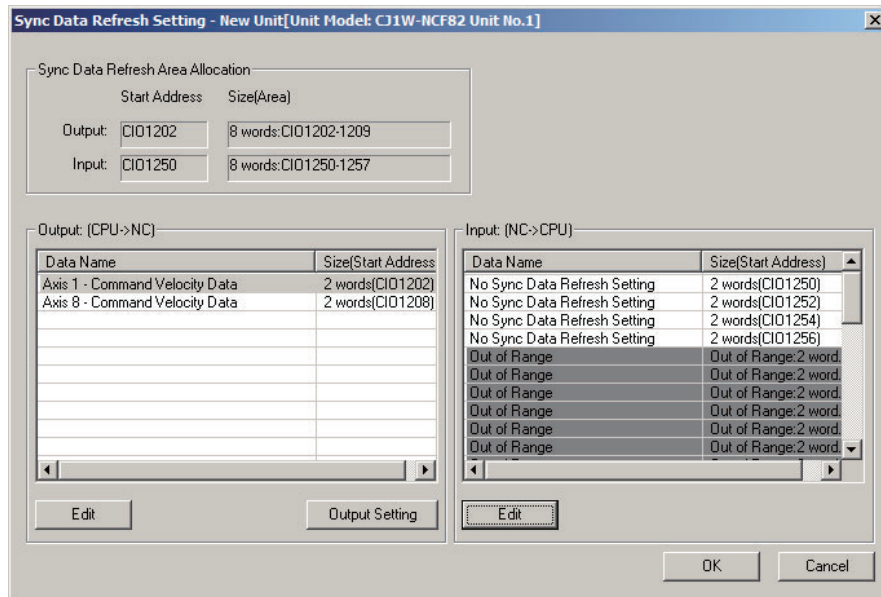

3. Transferring the PLC System Settings and PCU Settings

In the CX-Programmer's Transfer dialog box, select the Settings and Special Unit Setup and transfer the settings to the PLC.

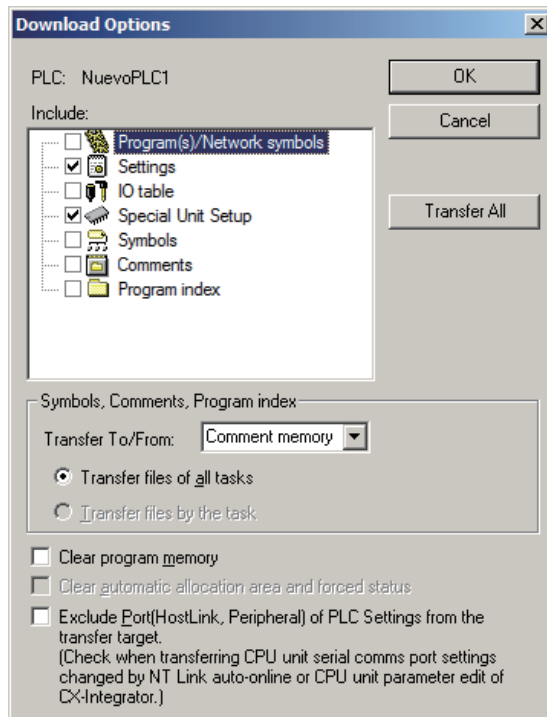

Notes on CPU Bus Unit Restart

In conjunction with the Synchronous Data Link function, CPU Bus Unit Restart (AR501) functions as follows.

- ♦ It does not allow individual restarting of synchronous units while the Synchronous Data Link is enabled.
- ♦ That is, executing a CPU Bus Unit Restart for one of the synchronous units causes all of the synchronous units to be restarted simultaneously. By doing so, it serves as a restart mechanism for the entire Synchronous Data Link.

7-Segment Display on PCU Front Face

When the Synchronous Data Link is enabled in the CJ1W-NC□82 PCU with unit version 1.3 or later, the dot to the right the first digit of the 7-segment display turns ON.



When the Synchronous Data Link is disabled, the first digit's dot is OFF.



11-2 Synchronous Data Link

Data exchange between the CPU Unit and synchronous units is performed by way of the Synchronous Data Link Memory Area.

The Synchronous Data Link Memory Area is allocated to words 1200 to 1295 in the I/O memory in the CPU Unit.

The type of data the CPU Unit exchanges with the allocated memory areas of each synchronous unit is determined based on the settings on both sides.

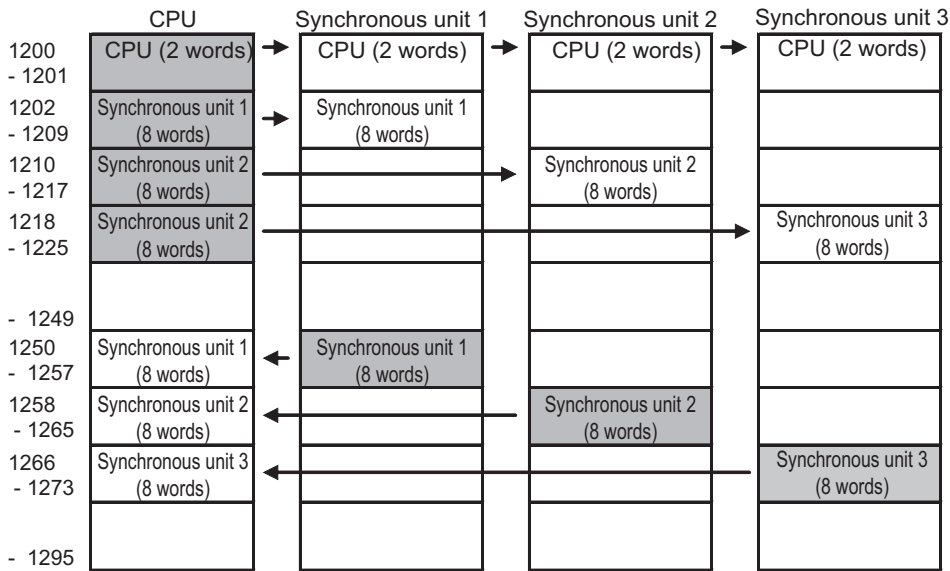

Synchronous Data Link Settings

First, on the CPU Unit, allocate the Synchronous Data Link Memory Area in the PLC System Settings.

1. Setting the Starting Word of the Input Memory Area

In the Synchronous Data Link Memory Area Allocations Settings, set the starting word of the input area used for the Synchronous Data Link function. Setting this causes the Synchronous Data Refresh Area Allocation to be divided into the output (CPU Unit to PCU) and input (PCU to CPU Unit) memory areas.

2. Registering the Synchronous Units

3. Setting Output Size and Input Size

For each synchronous unit you registered, set both the Output Size and Input Size of the Synchronous Data Link Memory Area.

For each unit, the output and input areas of the specified size are allocated in sequence. The output memory area for synchronous unit 1 starts at the beginning of the Synchronous Data Link Memory Area and the input memory area for synchronous unit 1 starts at the starting word of the Synchronous Data Link Input Memory Area, respectively.

For the CJ1W-NC□82 PCU, a maximum of 64 words can be allocated for the Synchronous Data Link Input Area.

Setting Example

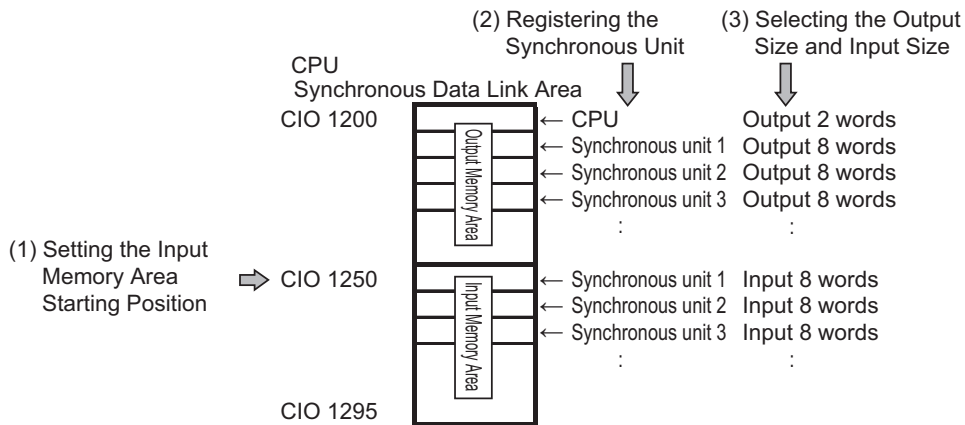

Next, set the I/O data type of the Synchronous Data Link from the synchronous unit using the PCU's parameters.

4. Selecting the Output Memory Area Allocated for the Synchronous Unit

In the output memory area allocated for your synchronous unit, specify how you want to use the words from the synchronous unit.

For a PCU for example, select the words you want to use to receive synchronous feeding command data for each axis.

5. Selecting the Input Memory Area Allocation of the Synchronous Unit

In the input memory area allocated for your synchronous unit, specify which words you want to use to send data from the synchronous unit.

For a PCU for example, you can select the words to which you send the command present position, feedback present position, and other data for each axis.

Setting Example

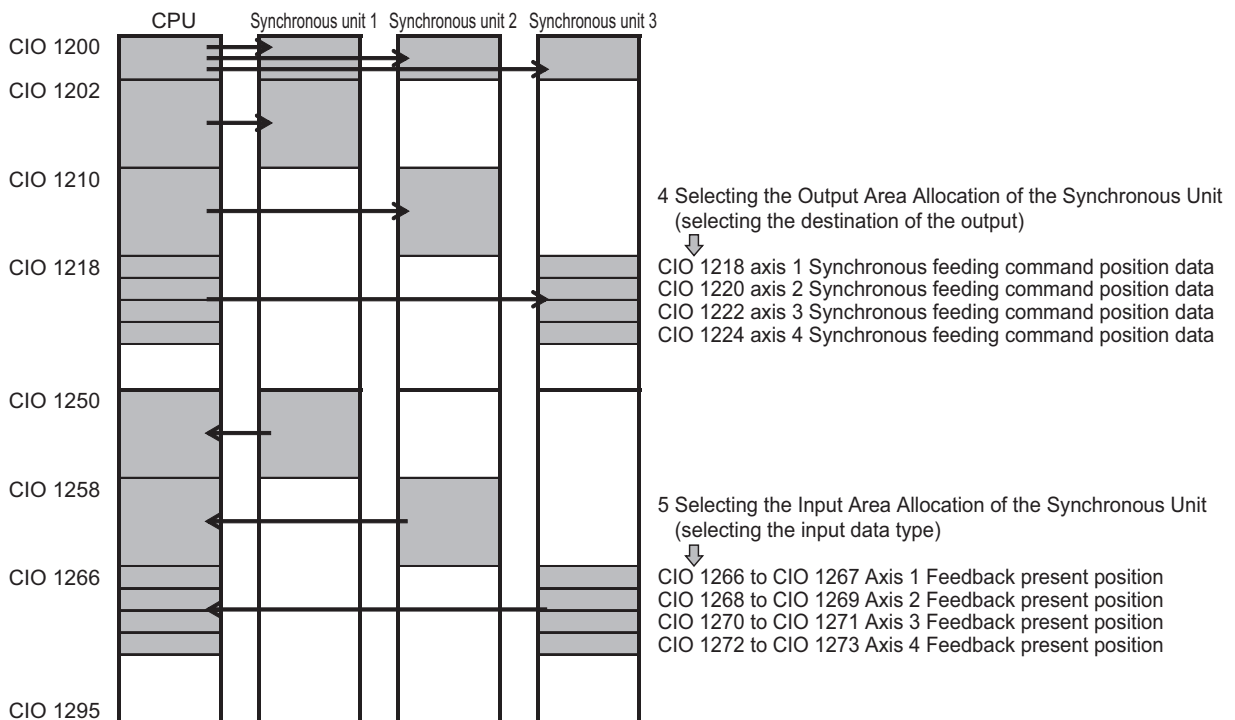

11-3 Synchronous Unit Stop Function

You can execute a command to stop the ongoing function from the CPU Unit to all synchronous units or any combination of the synchronous units on which the synchronous control is enabled.

Two types of stop functions offered for synchronous units: All Synchronous Unit Stop, which executes a stop command for all synchronous units, and Synchronous Group Stop, which executes a stop command for predefined groups of units.

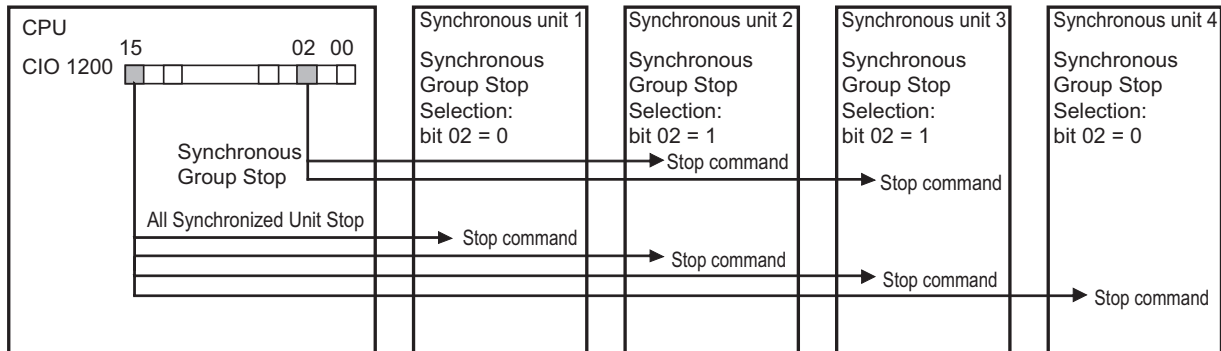

11

Synchronous Data Link

All Synchronous Unit Stop

The All Synchronous Unit Stop Bit is allocated to bit 15 of word 1200 in the Synchronous Data Link Memory Area.

Turning this bit ON executes a command to simultaneously stop the ongoing function for all synchronous units.

Synchronous Group Stop

The Synchronous Group Stop Bit is allocated to bits 00 to 14 of word 1200 in the Synchronous Data Link Memory Area.

Turning this bit ON executes a command to stop the ongoing function for a group of synchronous units you selected using the Synchronous Group Stop Selection axis parameter of the synchronous unit.

The following table shows the settings of the Synchronous Group Stop Selection axis parameter.

Parameter name	Bit	Function	Setting range	Default value
Synchronous Group Stop Selection	00	Select whether or not to stop the function when bit 00 of word 1200 in the Synchronous Data Link Memory Area turns ON. 0: Do not stop when bit 00 turns ON. 1: Stop when bit 00 turns ON.	0 to 1	0
	01	Select whether or not to stop the function when bit 01 of word 1200 in the Synchronous Data Link Memory Area turns ON. 0: Do not stop when bit 01 turns ON. 1: Stop when bit 01 turns ON.	0 to 1	0
	02	Select whether or not to stop the function when bit 02 of word 1200 in the Synchronous Data Link Memory Area turns ON. 0: Do not stop when bit 02 turns ON. 1: Stop when bit 02 turns ON.	0 to 1	0
	03	Select whether or not to stop the function when bit 03 of word 1200 in the Synchronous Data Link Memory Area turns ON. 0: Do not stop when bit 03 turns ON. 1: Stop when bit 03 turns ON.	0 to 1	0
	04	Select whether or not to stop the function when bit 04 of word 1200 in the Synchronous Data Link Memory Area turns ON. 0: Do not stop when bit 04 turns ON. 1: Stop when bit 04 turns ON.	0 to 1	0
	05	Select whether or not to stop the function when bit 05 of word 1200 in the Synchronous Data Link Memory Area turns ON. 0: Do not stop when bit 05 turns ON. 1: Stop when bit 05 turns ON.	0 to 1	0
	06	Select whether or not to stop the function when bit 06 of word 1200 in the Synchronous Data Link Memory Area turns ON. 0: Do not stop when bit 06 turns ON. 1: Stop when bit 06 turns ON.	0 to 1	0

11-3 Synchronous Unit Stop Function

Parameter name	Bit	Function	Setting range	Default value
Synchronous Group Stop Selection	07	Select whether or not to stop the function when bit 07 of word 1200 in the Synchronous Data Link Memory Area turns ON. 0: Do not stop when bit 07 turns ON. 1: Stop when bit 07 turns ON.	0 to 1	0
	08	Select whether or not to stop the function when bit 08 of word 1200 in the Synchronous Data Link Memory Area turns ON. 0: Do not stop when bit 08 turns ON. 1: Stop when bit 08 turns ON.	0 to 1	0
	09	Select whether or not to stop the function when bit 09 of word 1200 in the Synchronous Data Link Memory Area turns ON. 0: Do not stop when bit 09 turns ON. 1: Stop when bit 09 turns ON.	0 to 1	0
	10	Select whether or not to stop the function when bit 10 of word 1200 in the Synchronous Data Link Memory Area turns ON. 0: Do not stop when bit 10 turns ON. 1: Stop when bit 10 turns ON.	0 to 1	0
	11	Select whether or not to stop the function when bit 11 of word 1200 in the Synchronous Data Link Memory Area turns ON. 0: Do not stop when bit 11 turns ON. 1: Stop when bit 11 turns ON.	0 to 1	0
	12	Select whether or not to stop the function when bit 12 of word 1200 in the Synchronous Data Link Memory Area turns ON. 0: Do not stop when bit 12 turns ON. 1: Stop when bit 12 turns ON.	0 to 1	0
	13	Select whether or not to stop the function when bit 13 of word 1200 in the Synchronous Data Link Memory Area turns ON. 0: Do not stop when bit 13 turns ON. 1: Stop when bit 13 turns ON.	0 to 1	0
	14	Select whether or not to stop the function when bit 14 of word 1200 in the Synchronous Data Link Memory Area turns ON. 0: Do not stop when bit 14 turns ON. 1: Stop when bit 14 turns ON.	0 to 1	0
	15	—	—	—

11-4 Errors Detected in Synchronous Units

When the Synchronous Data Link function is enabled, all the synchronous units are controlled in sync with the CPU Unit's synchronous cycle time and show a specific phenomenon if an error occurs.

This section explains errors that may occur due to synchronous control.

Synchronous Time Monitoring Timeout

Synchronous units receive a timing signal from the CPU Unit whenever the sync cycle time elapses. If they have not received this signal when four times the unit control cycle time is elapsed since the previous notification, a synchronous time monitoring timeout occurs.

If this error occurs, the synchronous units cancel the ongoing process and stop synchronous control. To restore normal operation, you need to remove the cause of the error and restart each synchronous unit.

Synchronous Data Link Reception Error

A Synchronous Data Link reception error occurs if the timing signal sent from the CPU Unit each time the sync cycle time elapses has not been received successfully by synchronous units two times in a row.

If this error occurs, the synchronous units cancel the ongoing process, but continue the synchronous control. To restore normal operation, remove the cause of the error and then execute an error reset on each synchronous unit.

Synchronous Data Link Reception Warning

A Synchronous Data Link reception warning occurs if the timing signal sent from the CPU Unit each time the sync cycle time elapses has not been received successfully by synchronous units only once. This is a warning, which may continue to the error phase.

In this case, the synchronous data received in the cycle is discarded and the synchronous units continue the ongoing process based on the data received in the previous cycle.

Synchronous Control Cycle Setting Error

A synchronous control cycle setting error occurs if the PCU's internal control cycle is not consistent with and synchronous cycle time of the CPU Unit.

Make sure that the PCU's internal control cycle (A) is the same or shorter than the CPU Unit's sync cycle time (B). The setting range is $0.5 \text{ ms} \leq B \leq 10 \text{ ms}$.

To restore normal operation, you need to remove the cause of the error and restart each synchronous unit.

11-5 Synchronous Feeding Position

Synchronous feeding position is the follow-up positioning system (Electric Shaft function) that operates in sync with the PCU's Servo Drive axis, which is the master axis.

Outline of Operation

Outline of the Electric Shaft Function

You can configure the Electric Shaft function, a follow-up positioning system that operates in sync with the master axis while the Synchronous Feeding Position flag in the Direct Operation Command Memory Area for the target Servo Drive axis (hereafter referred to as slave axis) of the synchronous feeding position command is ON.

The present position of the follow-up target master axis can be set to the feedback present position or the command present position in the Synchronous Feeding Position Function Selection settings.

The auxiliary axis can be used to compensate for the slave axis position value.

The auxiliary position value can be set to the Synchronous Data Link Memory Area allocated as Electric Shaft Auxiliary Axis Command Data for each axis of the PCU.

The slave axis position value is defined as the sum of main position value (derived from the master axis position value) and the auxiliary position value (hereafter referred to as output position value) multiplied by the output filter value.

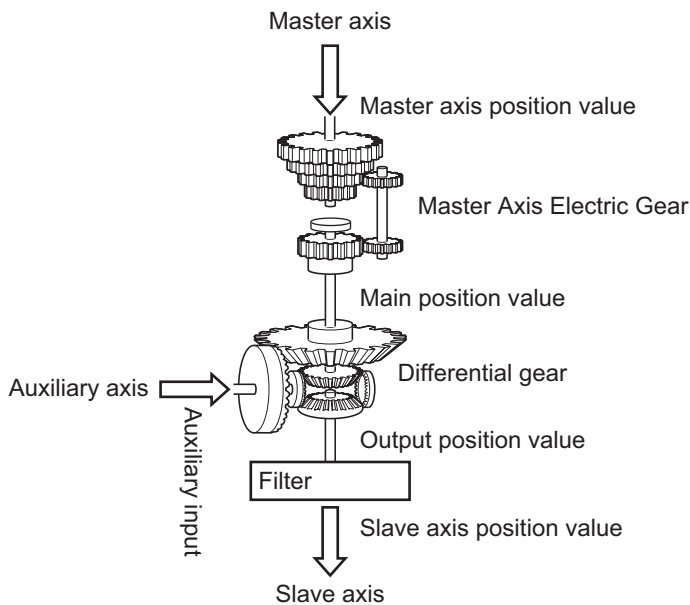

Moreover, the synchronous feeding position function provides the Synchronous Feeding torque option settings, by which you can also output torque data such as torque feedforward data and torque limit data.

Application Example of the Synchronous Feeding Position Command

Bilateral Operation

Using the synchronous feeding position command lets you perform bilateral operation with two or more axes by using the same position data, as if you were operating a single axis with the direct operation command.

It is also possible to configure an application in which the auxiliary axis is used to compensate deviation between axes.

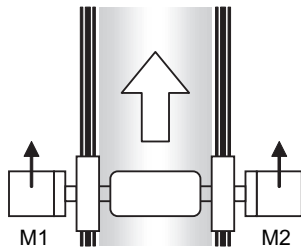

Bilateral operation of 2 axes

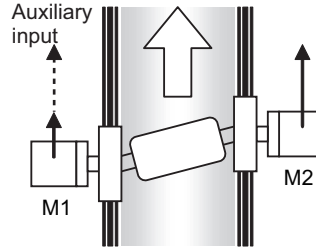

You can compensate the axis position temporarily by providing the auxiliary position input value if the position deviation occurs.

Example of Bilateral Operation Configuration

This is an example of configuring bilateral operation with a virtual axis that serves as the master axis and two physical axes that actually perform bilateral movements.

First, execute the synchronous feeding position command for the two slave axes to configure the Electric Shaft function for each of them.

Then, execute the direct operation command for the master axis. Now, you can position the axes to perform bilateral operation.

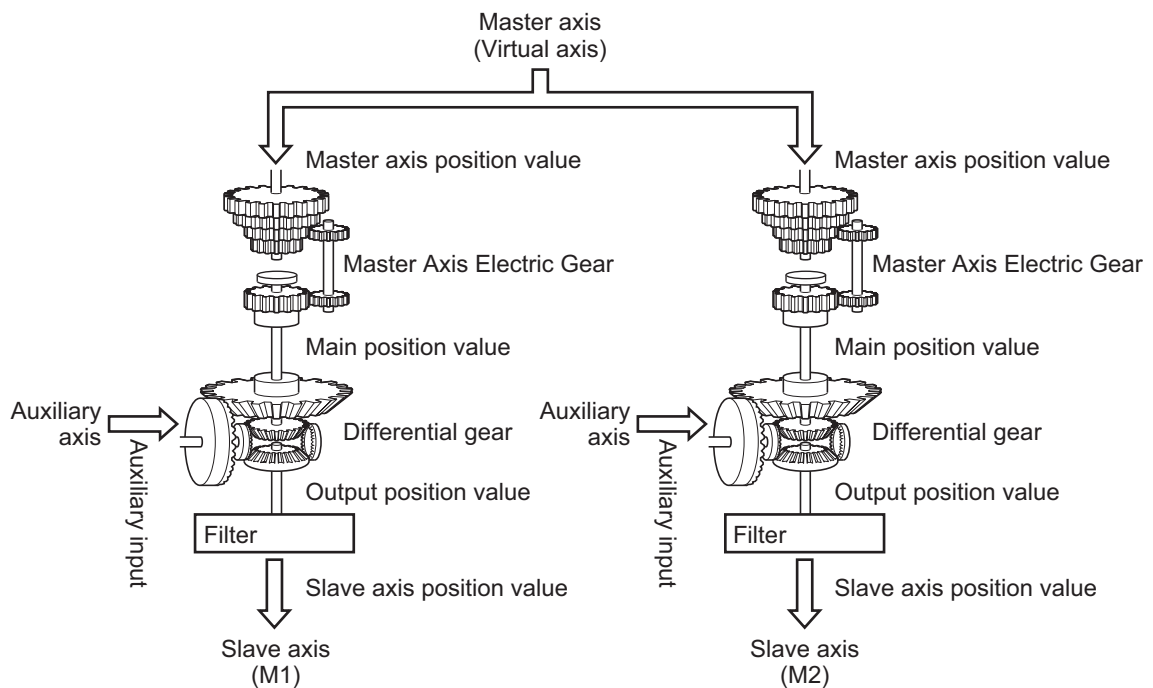



Reference

- ♦ In the bilateral operation example above, set the parameters for the two slave axes in the same way.
- ♦ The bilateral operation example above may be configured with a single physical axis serving as the master axis and a single physical axis serving as the slave axis. This configuration, however causes a delay of one unit control cycle in the command position of the slave axis in relation to that of the master axis.
- ♦ The Electric Shaft function has no limitation on the number of axes used.
- ♦ Create a ladder program for monitoring the deviation between axes. Then, use the ladder program to monitor the difference in the feedback present position between axes and, if it is more than you expected, turn ON the Immediate Stop Bit or the Deceleration Stop Bit for the master axis to stop the slave axis.

Operations with the Synchronous Feeding Position Command

This section describes operations you can perform with the synchronous feeding position command, from the start to stop.

Procedure for Using the Synchronous Feeding Position

Before executing the synchronous feeding position command, you need to perform the following settings and allocations.

- ♦ Settings related to the Synchronous Data Link function
- ♦ Settings related to the Electric Shaft function
- ♦ Allocations of Direct Operation Command Memory Area
- ♦ Allocations of Axis Status Memory Area

Refer to *Direct Operation Command Memory Area* on page 6-91 for the Direct Operation Command Memory Area. Refer to *Axis Status Memory Area* on page 6-100 for the Axis Status Memory Area.

The following procedure assumes that the above settings and memory area allocations are already completed.

1. Setting the Synchronous Data Link and Electric Shaft parameters

Register the PCU as a synchronous unit and set the required parameters.

Allocate the output area of auxiliary position data and torque option data for each target axis of the synchronous feeding position command and complete the required Electric Shaft system settings such as the master axis gear ratio.

2. Starting the Synchronous Data Link function

3. Putting the Servo Drive in operating status

4. Starting the Synchronous Feeding Position function

Turn ON the Synchronous Feeding Position flag in the Direct Operation Command Memory Area.

The Synchronous Feeding Position Acknowledged Flag in the Axis Status Memory Area turns ON. The PCU is now ready to accept the synchronous feeding position command.

5. Executing axis operation commands

Execute axis direct operation and other commands for the master axis.

6. Putting in auxiliary position data and torque data

If you are using the auxiliary axis, put auxiliary position data in the Synchronous Data Link auxiliary position value output area. If you are also using the synchronous feeding torque option function, put torque data in the torque data output area.

7. Stopping the synchronous feeding position function

Turn OFF the Synchronous Feeding Position flag in the Direct Operation Command Memory Area.

The Axis Busy Flag turns OFF. The synchronous feeding position command is now stopped.

Behavior of Deceleration Stop during Synchronous Feeding Position Operation

During synchronous feeding position operation, executing a deceleration stop works as an immediate stop.

Timing Chart

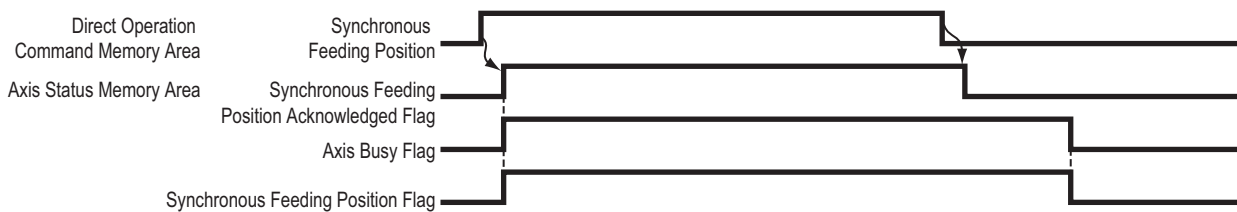

Synchronous Feeding Position Controlled Components

This section describes the components you can control using the synchronous feeding position command.

Master Axis Multiplier

The main position value is defined as the amount of relative movement of the master axis per unit control cycle of the master axis multiplier multiplied by the electronic gear ratio. The numerator of the electronic gear ratio accepts can take a negative number, so you can rotate the master axis multiplier in the reverse direction to the master axis.

The present position of the master axis can be set to either the command or the feedback present position, each of which uses the present position data from the previous control cycle.

Operating Principle of the Master Axis Multiplier

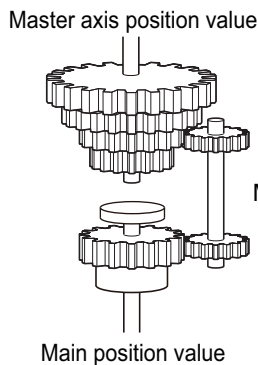

$$\text{Main position value} = \frac{\text{Master Axis Position Value} \times \text{Master Axis Electric Gear Numerator}}{\text{Master Axis Electric Gear Denominator}}$$

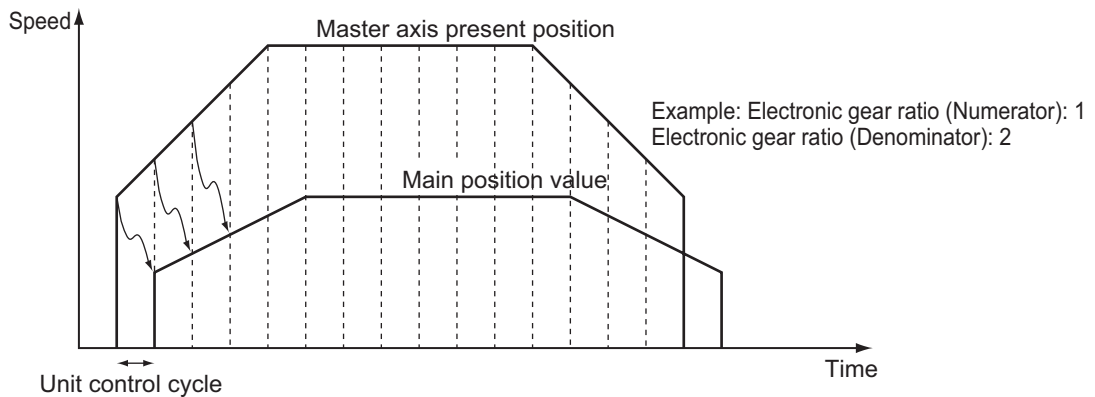

11-5 Synchronous Feeding Position

Master Axis Settings

You can select the master axis data and the master axis number for the synchronous feeding position command.

The Synchronous Feeding Position Function Selection settings are continuously updated and applied when the synchronous feeding position command is executed.

Parameter name	Function	Setting range	Unit	Default value
Synchronous Feeding Position Function Selection	Select the master axis for the synchronous feeding position command. 0: Do not select. 3: Electric Shaft (The feedback present position of the Servo Drive axis in the same unit is used as the master axis.) 4: Electric Shaft (The command present position of the Servo Drive axis in the same unit is used as the master axis.)	0, 3 to 4	—	0
Synchronous Feeding Position Master Axis No.	Specify the Servo Drive axis number in the PCU.	0 to 16	—	0

Electronic Gear Settings

Set the multiplier used to determine the slave axis position value with respect to that of the master axis achieved with the synchronous feeding position command.

The Master Axis Multiplier settings are continuously updated and applied when the synchronous feeding position command is executed.

Parameter name	Function	Setting range	Unit	Default value
Synchronous Feeding Position Master Axis Multiplier Numerator	Set the numerator of the multiplier used to determine the slave axis position value with respect to that of the master axis.	-10,000 to 10000	—	0
Synchronous Feeding Position Master Axis Multiplier Denominator	Set the denominator of the multiplier used to determine the slave axis position value with respect to that of the master axis.*1	0 to 10,000	—	0

*1. Setting this to 0 means a multiplication factor of 1.



Precautions for Correct Use

Note that executing a preset operation (for example, by turning ON the Present Position Preset Bit) for the master axis may cause the main position value to change suddenly.

However, the master axis does not follow the origin search preset operation.



Reference

- If the master axis counting mode is set to Rotation Axis, the master axis position value is always calculated as the shortest route.
- If the slave axis counting mode is set to Rotation Axis, the PCU outputs the amount of movement specified as the main position value even when the amount of change in the main position value per unit control cycle has exceeded the rotation axis upper limit.

Differential Gear

The differential gear system adds the main position value and the auxiliary input value to yield an output position value.

It is possible to compensate for the movement of the master axis by specifying an auxiliary input value.

Operating Principle of the Differential Gear

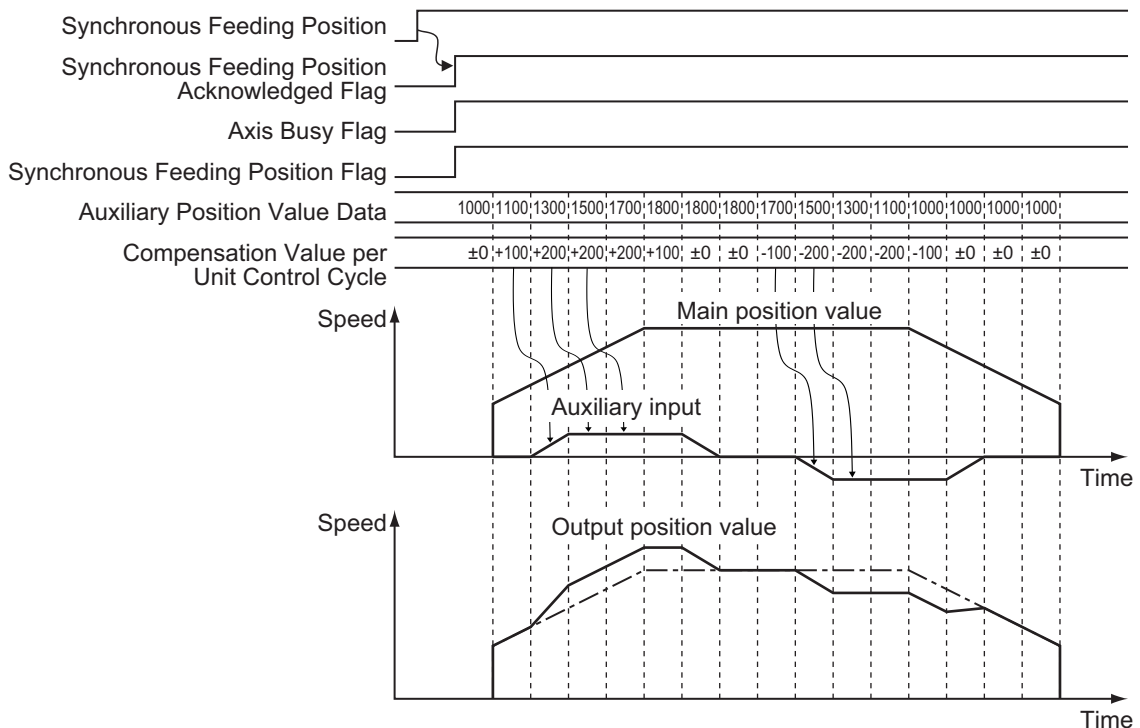
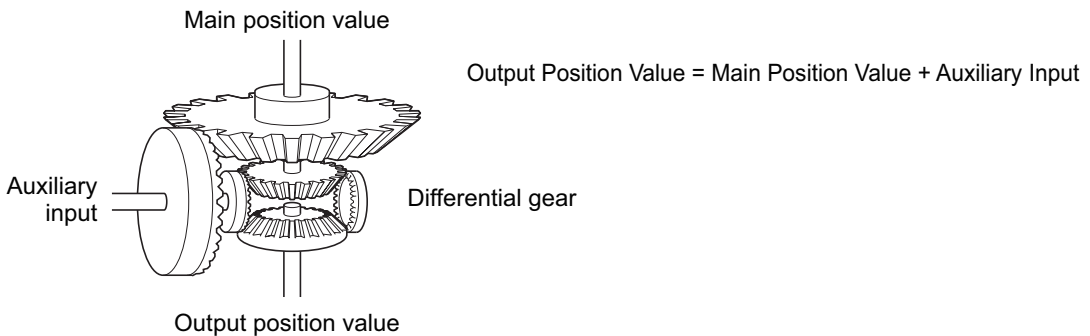

Operating Principle of the Auxiliary Position Value

An auxiliary position value must be specified as an absolute value in the auxiliary position value output area.

For example, define the auxiliary position value at which the synchronous feeding position command is executed as 1000 (as the command unit).

To add the value 800 as the amount of movement during a synchronous feeding position operation, specify the auxiliary position value as 1800.

If you want to compensate the position in any cycles, update the auxiliary position value on the program (such as 1000, 1100, 1300, ..., or 1800, etc.).

Auxiliary Axis Settings

Select whether to use the slave axis as the target of the synchronous feeding position command and specify where in the Synchronous Data Link Memory Area the data to be output as the auxiliary position value is stored.

The auxiliary settings are continuously updated and applied when the synchronous feeding position command is executed.

Parameter name	Function	Setting range	Unit	Default value
Synchronous Feeding Auxiliary Axis Selection	Select the auxiliary axis for the synchronous feeding position command. 0: Do not use the use the slave axis. 1. Use the auxiliary axis as the target of Synchronous Data Link output.	0 to 1	–	0
Synchronous Feeding Auxiliary Axis Command Data Offset	Specify where the command data is stored as the relative position (number of words) to the first word of the Synchronous Data Link data to be output.	0 to Output Size Upper Limit - 2	–	0



Precautions for Correct Use

- ♦ The value at which the synchronous feeding position command is executed is defined as the compensation starting point (offset 0) of auxiliary axis command data. In the Auxiliary Axis Command Data, set an absolute value taking into account the amount of relative compensation to the origin.
- ♦ If the slave axis counting mode is set to Rotation Axis, set the input range of auxiliary axis command data within the range of rotation axis counter. Note that difference in the auxiliary axis command data is always calculated as the shortest route. To avoid false detection of the rotation direction, set the amount of compensation per sync cycle to less than one fourth of the Rotation Axis Upper Limit parameter value.
- ♦ If the slave axis counting mode is set to Rotation Axis and the result after taking into account the amount of relative compensation to the compensation starting point exceeds the rotation axis upper limit, adjust the value to within the setting range of the counter.
- ♦ Before updating the auxiliary axis command data, check that the Synchronous Feeding Position Acknowledged Flag in the Axis Status Memory Area has turned ON in the synchronous interrupt task.

Output Filter

Use this parameter to filter the output of the slave axis by using the filter system that helps suppress its rapid braking due to a sudden change in the movement of the master or auxiliary axis.

Operating Principle of the Output Filter

The output filter performs the following calculations in the order shown to determine the slave axis position value per unit control cycle.

- (1) **Output filter remaining position value = Output filter remaining position value + Output position value per unit control cycle**
- (2) **Slave axis position value per unit control cycle = Output filter remaining position value / (Output filter constant + 1)**
- (3) **Output filter remaining position value = Output filter remaining position value - Slave axis position value per unit control cycle**

For example, if the Synchronous Feeding Position Filter Constant axis parameter is set to 5 decimal, the filter output filter constant above is 0.5 because its setting unit is 0.1. The following shows an example of command output data when a command value of 10 is input to the output filter per unit control cycle.

Unit control cycle	Output position value per unit control cycle (Input command value)	Output filter remaining position value	Slave axis position value per unit control cycle (Actual output command value)
1st cycle	10	3	7
2nd cycle	10	4	9
3rd cycle	10	4	10
4th cycle	10	4	10
:	:	:	:

The output filter position value is an internal variable used in the output filter system. The output position value per unit control cycle is added to the output filter remaining position value. The result is then averaged using the filter constant to yield the slave axis position value per unit control cycle.

Finally, the remaining position value is carried over to the calculation for the next cycle, as a new filter remaining position value.

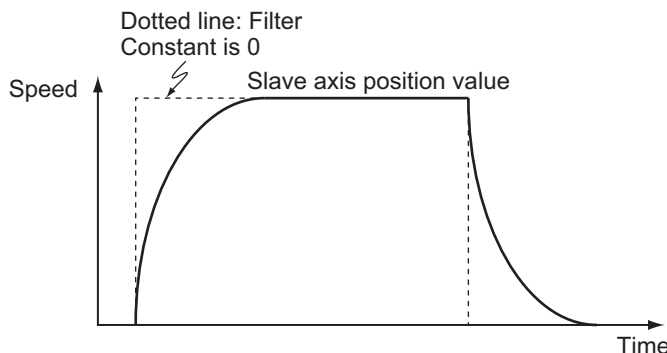

11-5 Synchronous Feeding Position

Output Filter Settings

Set the output filter used to determine the slave axis position value with respect to that of the slave axis achieved with the synchronous feeding position command.

The slave axis position value you set is multiplied by the filter constant and then output from the filter.

The Filter Constant setting is continuously updated and applied when the Synchronous Feeding Position command is executed.

Parameter name	Function	Setting range	Unit	Default value
Synchronous Feeding Position Filter Constant	Set the output filter value. 0: Function disabled 1 to 32,767: Output filter setting. The output filter value is a tenth of this setting.	0 to 32,767	–	0



Reference

If the slave axis position value exceeds the maximum speed, the output to the Servo Drive will be restricted to the maximum speed.

Torque Option Function

This section describes the torque option settings for the synchronous feeding position function.

Outline of Operation

While the Synchronous Feeding Position flag in the Direct Operation Command Memory Area is ON, the torque data selected in the Synchronous Feeding Torque Option Selection settings is output.

The CPU Unit and PCU exchange data as shown below.

You can select two types of torque data: option data 1 (1 word) and option command data 2 (1 word).

Although you may use only one of these types depending on your settings, this function always occupies two words in the Synchronous Data Link Area. If set to 0, it does not occupy the torque data area.

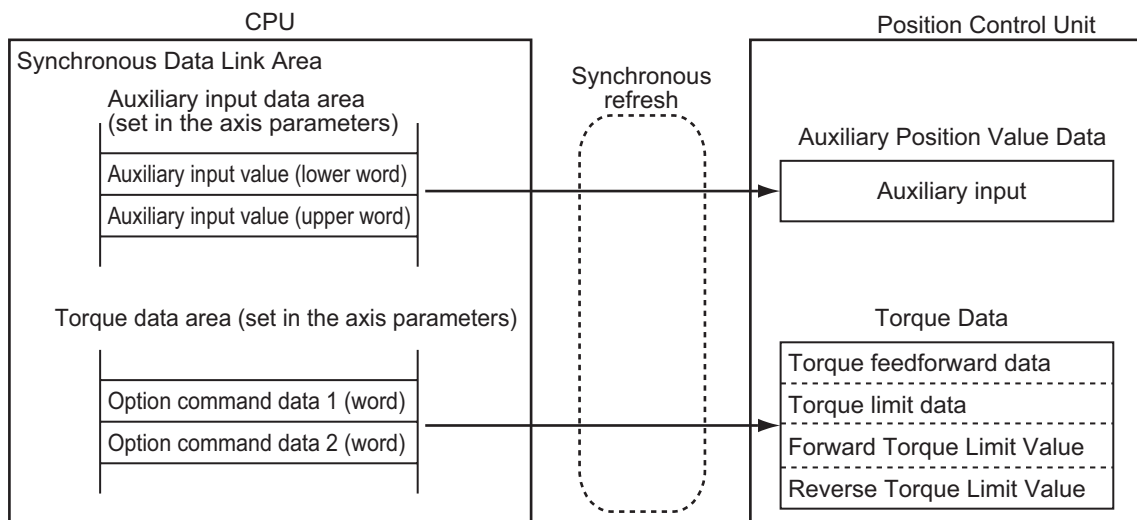

Precautions for Correct Use

- ♦ To use the torque option function, you must complete the required Synchronous Data Link settings before executing the synchronous feeding position command.
- ♦ Note that turning OFF the Synchronous Feeding Position flag causes the torque feedforward data to return to 0% and the torque limit data to the same value as the maximum torque, which may result in rapid braking.



Reference

- ♦ When using torque limit data, forward torque limit data, or reverse torque limit data, the Forward Torque Limit Bit or Reverse Torque Limit Bit in the Direct Operation Command Memory Area will take precedence even if the Forward Torque Limit Bit or Reverse Torque Limit Bit in the Manual Operation Command Memory Area turns ON, respectively.
- ♦ Even if you set each torque data to a value greater than the Max Torque parameter, the Max Torque parameter value will be output.
- ♦ To use torque limit data, you must change the value of the the Torque Limit Selection servo parameter object (3521 hex) in the OMNUC G5-series Servo Drive to 5.
For details, refer to *10-4 Torque Limits* on page 10-19.
- ♦ To use the torque option function, you need PDO mappings.
If you execute the synchronous feeding position command for an axis without the require PDO mappings, the Insufficient PDO Allocation error occurs at startup.

Torque Data List

You can select the following types of torque data.

Name	Bit	Function	Unit
Torque Feedforward Data	0 to 15	Set the torque feed forward value. Setting range: D8F0 to 2710 hex (-10,000 to 10,000 [0.1%])	0.1% *1
Torque Limit Data	0 to 15	Set the torque limit value in both directions. Setting range: 0 to 2710 hex (0 to 10,000 [0.1%])	0.1% *1
Forward Torque Limit Data	0 to 15	Set the forward torque limit value. Setting range: 0 to 2710 hex (0 to 10,000 [0.1%])	0.1% *1
Reverse Torque Limit Data	0 to 15	Set the reverse torque limit value. Setting range: 0 to 2710 hex (0 to 10,000 [0.1%])	0.1% *1

*1. The ratio to the rated torque. Refer to *OMNUC G5-series AC Servomotors/Servo Drives with Built-in EtherCAT Communications User's Manual* (Cat. No. I573) for details.

Torque Option Parameter Settings

Select how the Synchronous Feeding Torque options work and specify where in the Synchronous Data Link Memory Area the data to be output as the torque data is stored.

Changes to the synchronous feeding torque option settings are continuously updated.

Parameter name	Function	Setting range	Unit	Default value
Synchronous Feeding Torque Option Selection	Select the torque option function. 0: Do not use option 1; do not use option 2. 1: Use option 1 as torque feedforward data; use option 2 as torque limit data (both directions). 2: Use option 1 as torque feedforward data; do not use option 2. 3: Do not use option 1; use option 2 as torque limit data (both directions). 4: Use option 1 as positive torque limit data; use option 2 as negative torque limit data.	0 to 4	–	0
Synchronous Feeding Torque Option Command Data Offset	Specify where the command data is stored as the relative position (number of words) to the first word of the Synchronous Data Link data to be output.	0 to Output Size Upper Limit - 2	–	0

11-6 Synchronous Feeding Velocity

The synchronous feeding velocity function enables PCUs to perform speed control without position loop in the CSV mode by sequentially receiving the command speed from the CPU Unit through the Synchronous Data Link.

Outline of Operation

This function causes PCUs to output the command speed while the Synchronous Feeding Position flag in the Direct Operation Command Memory Area is ON.

The absolute value of the command speed is set in command units per second in the Synchronous Data Link Memory Area as the Synchronous Feeding Command Speed Data for each axis of the PCU.

The synchronous feeding velocity function can be used in conjunction with the synchronous feeding torque option function to output also torque data. Torque data includes the torque feedforward data and the torque limit data.

11

Synchronous Data Link

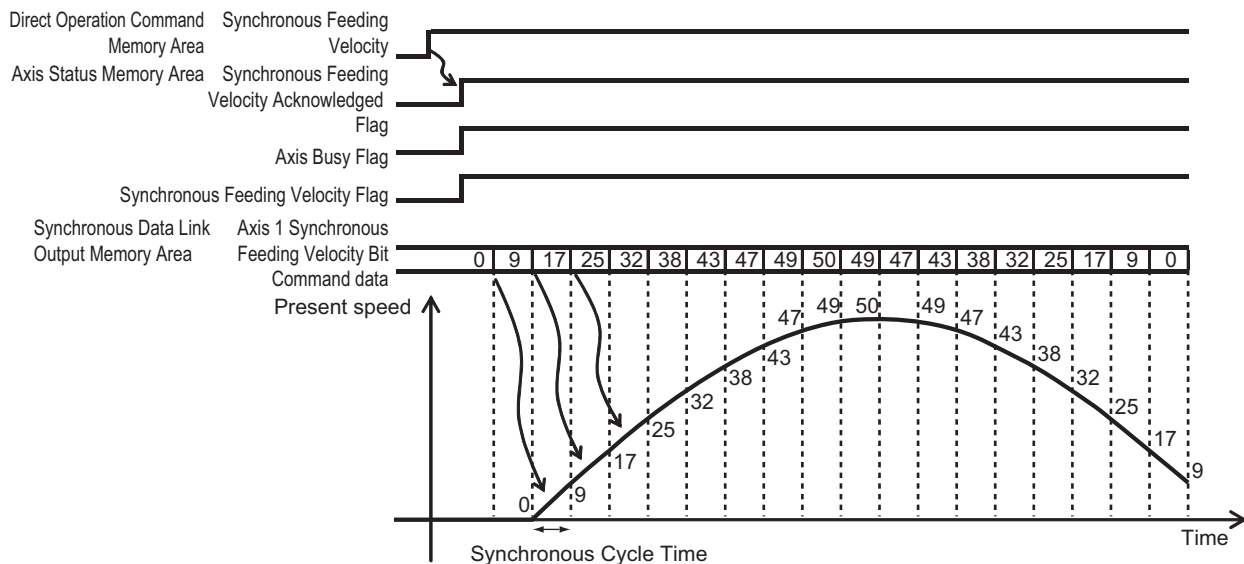

Precautions for Correct Use

The synchronous feeding velocity function uses the speed control (CSV) mode of the Servo Drive and therefore the PCU has no specific command present position value during operation. Instead, it retains the same value as the feedback present position value for it. This may cause the monitored command present position to change at the start and end of synchronous feeding velocity command execution.



Reference

- ♦ A synchronous feeding velocity operation cannot be started when any other operation is in progress.
- ♦ During synchronous feeding velocity operation, executing a deceleration stop causes an immediate stop.
- ♦ If the command speed exceeds the maximum speed that you set in the axis parameter settings, the command speed will be limited to the maximum speed.
- ♦ To use the synchronous feeding velocity function, you need PDO mappings. If you execute the synchronous feeding velocity command for an axis without the required PDO mappings, the Insufficient PDO Allocation error occurs at startup.
- ♦ Turning ON the Override Enable Bit has no effect on the synchronous feeding velocity function.

Operations with Synchronous Feeding Velocity Command

This section describes operations you can perform with the synchronous feeding velocity command, from the start to stop.

Procedure for Using the synchronous Feeding Velocity

Before executing the synchronous feeding velocity command, you need to complete the settings related to the Synchronous Data Link function, as well as the allocations of the Direct Operation Command Memory Area and the Axis Status Memory Area.

Refer to *Direct Operation Command Memory Area* on page 6-91 for the Direct Operation Command Memory Area. Refer to *Axis Status Memory Area* on page 6-100 for the Axis Status Memory Area.

The following procedure assumes that allocations to these memory areas are already completed.

1. Synchronous Data Link Settings

Register the PCU as a synchronous unit and allocate the output area of synchronous feeding command speed data and torque option data for each target axis of the synchronous feeding velocity command.

2. Starting the Synchronous Data Link function

3. Putting the Servo Drive in operating status

4. Starting the synchronous feeding velocity function

Turn ON the Synchronous Feeding Velocity flag in the Direct Operation Command Memory Area. The Synchronous Feeding Velocity Acknowledged Flag in the Axis Status Memory Area turns ON. The PCU is now ready to accept the synchronous feeding velocity command.

5. Putting in synchronous feeding command speed data and torque data

Put a command speed as an absolute value in the Synchronous Command Speed Value output area of the Synchronous Data Link.

If you are also using the torque option function, put torque data in the torque data output area.

6. Stopping the synchronous feeding velocity function

Turn OFF the Synchronous Feeding Velocity Flag in the Direct Operation Command Memory Area. The Axis Busy Flag turns OFF. The synchronous feeding velocity command is now stopped.

Synchronous Feeding Speed Parameter Settings

Select whether to use the master axis as the target of the Synchronous Feeding Velocity command and specify where in the Synchronous Data Link Memory Area the data to be output as the command speed is stored.

The Synchronous Feeding Velocity Function Selection settings are continuously updated and applied when the Synchronous Feeding Velocity command is executed.

Parameter name	Function	Setting range	Unit	Default value
Synchronous Feeding Velocity Function Selection	Select whether to use the master axis as the target of the Synchronous Feeding Velocity command. 0: Do not select. 1. Use the master axis as the target of Synchronous Data Link output.	0 to 1	—	0
Synchronous Feeding Velocity Command Data Offset	Specify where the command data is stored as the relative position (number of words) to the first word of the Synchronous Data Link data to be output.	0 to Output Size Upper Limit - 2	—	0

Behavior of Deceleration Stop during Synchronous Feeding Velocity Operation

During synchronous feeding operation, executing a deceleration stop works as an immediate stop.



Precautions for Correct Use

- ◆ If you are creating a user program that uses a combination of the counter-slave feedback present position of the synchronous feeding velocity function and that of the remote I/O to construct a full-closed control system, check carefully (by using the torque limit function, for example) to ensure that it runs successfully. Then, move on to the actual production operation.
- ◆ Check the PCU Control Input Memory Area and the Communications Status Memory flag in the Remote I/O Communications Status Memory Area to take the appropriate action according to the status. Should you find an error, stop the processes that use input/output data or take other countermeasures.

Torque Option Function

This section describes the torque option settings for the synchronous feeding velocity function.

Outline of Operation

While the Synchronous Feeding Velocity Flag in the Direct Operation Command Memory Area is ON, the torque data selected in the Synchronous Feeding Torque Option Selection settings is output.

The CPU Unit and PCU exchange data as shown below.

You can select two types of torque data: option data 1 (1 word) and option command data 2 (1 word).

Although you may use only one of these types depending on your settings, this function always occupies two words in the Synchronous Data Link Area.

If set to 0, it does not occupy the torque data area.

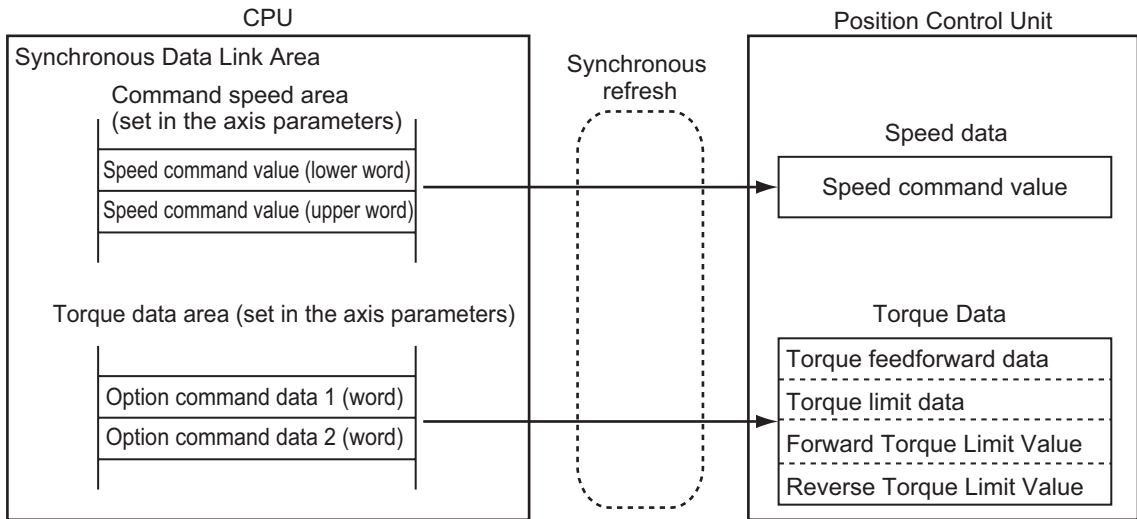



Precautions for Correct Use

- ♦ To use the torque option function, you must complete the required Synchronous Data Link settings before executing the synchronous feeding velocity command.
- ♦ Note that turning OFF the Synchronous Feeding Velocity flag causes the torque feedforward data to return to 0% and the torque limit data to the same value as the maximum torque, which may result in rapid braking.



Reference

- ♦ When using torque limit data, forward torque limit data, or reverse torque limit data, the Forward Torque Limit Bit or Reverse Torque Limit Bit in the Direct Operation Command Memory Area will take precedence even if the Forward Torque Limit Bit or Reverse Torque Limit Bit in the Manual Operation Command Memory Area turns ON, respectively.
- ♦ Even if you set each torque data to a value greater than the Max Torque parameter, the Max Torque parameter value will be output.
- ♦ To use torque limit data, you must change the value of the the Torque Limit Selection servo parameter object (3521 hex) in the OMNUC G5-series Servo Drive to 5. For details, refer to *10-4 Torque Limits* on page 10-19.
- ♦ To use the torque option function, you need PDO mappings. If you execute the synchronous feeding velocity command for an axis without the require PDO mappings, the Insufficient PDO Allocation error occurs at startup.

Torque Data List

You can select the following types of torque data.

Name	Bit	Function	Unit
Torque Feed Forward Data	0 to 15	Set the torque feed forward value. Setting range: D8F0 to 2710 hex (-10,000 to 10,000 [0.1%])	0.1% *1
Torque Limit Data	0 to 15	Set the torque limit value in both directions. Setting range: 0 to 2710 hex (0 to 10,000 [0.1%])	0.1% *1
Forward Torque Limit Data	0 to 15	Set the forward torque limit value. Setting range: 0 to 2710 hex (0 to 10,000 [0.1%])	0.1% *1
Reverse Torque Limit Data	0 to 15	Set the reverse torque limit value. Setting range: 0 to 2710 hex (0 to 10,000 [0.1%])	0.1% *1

*1. The ratio to the rated torque. Refer to *OMNUC G5-series AC Servomotors/Servo Drives with Built-in EtherCAT Communications User's Manual* (Cat. No. I573) for details.

Torque Option Parameter Settings

Select how the Synchronous Feeding Torque options work and specify where in the Synchronous Data Link Memory Area the data to be output as the torque data is stored.

Changes to the synchronous feeding torque option settings are continuously updated.

Parameter name	Function	Setting range	Unit	Default value
Synchronous Feeding Torque Option Selection	Select the torque option function. 0: Do not use option 1; do not use option 2. 1: Use option 1 as torque feedforward data; use option 2 as torque limit data (both directions). 2 Use option 1 as torque feedforward data; do not use option 2. 3: Do not use option 1; use option 2 as torque limit data (both directions). 4: Use option 1 as positive torque limit data; use option 2 as negative torque limit data.	0 to 4	–	0
Synchronous Feeding Torque Option Command Data Offset	Specify where the command data is stored as the relative position (number of words) to the first word of the Synchronous Data Link data to be output.	0 to Output Size Upper Limit - 2	–	0

11-7 Synchronous Feeding Torque

The synchronous feeding torque function enables PCUs to perform torque control by sequentially receiving the command torque from the CPU Unit through the Synchronous Data Link.

Outline of Operation

This function causes PCUs to output the command torque while the Synchronous Feeding Torque flag in the Direct Operation Command Memory Area is ON.

The absolute value of the command torque is set in increments of 0.1% of the rated torque in the Synchronous Data Link Memory Area as the Synchronous Feeding Command Torque Data for each axis of the PCU.

The synchronous feeding torque function can be used in conjunction with the synchronous feeding velocity option function to output also velocity limitation data.

11

Synchronous Data Link

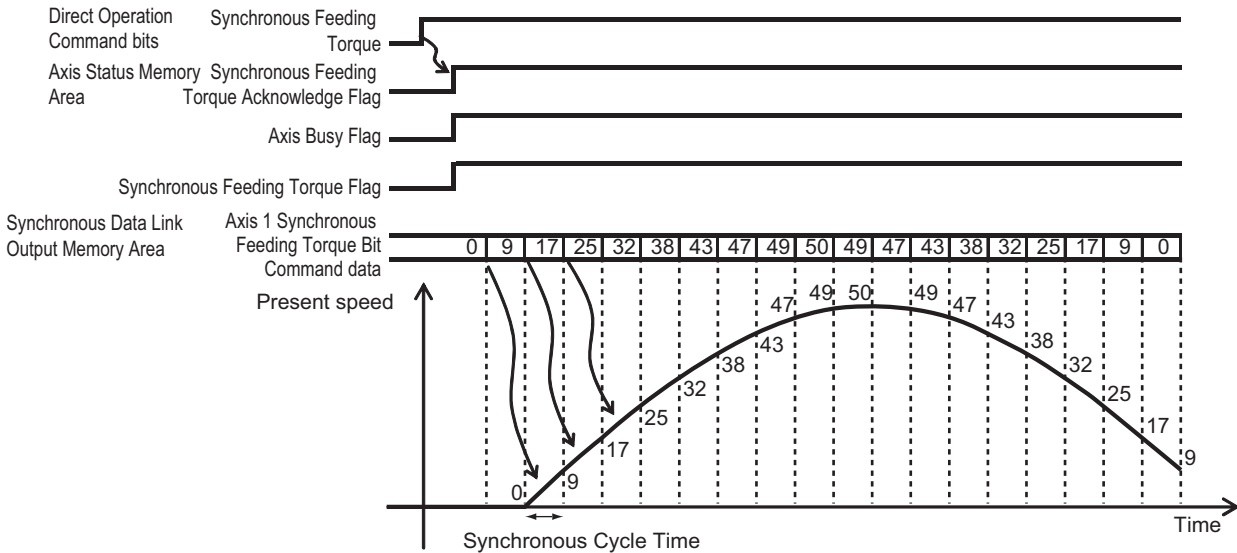

Precautions for Correct Use

- To execute the synchronous feeding torque command, you must change the value of the the Velocity Limitation Selection servo parameter object (3317 hex) in the OMNUC G5-series Servo Drive to 1 (Velocity Limitation from ECAT). If it is not changed, the PCU may not be able to stop the axis correctly.
- The synchronous feeding torque function uses the torque control (CST) mode of the Servo Drive and therefore the PCU has no specific command present position value during operation. Instead, it retains the same value as the feedback present position value for it. This may cause the monitored command present position to change at the start and end of synchronous feeding torque command execution.



Reference

- ♦ The synchronous feeding torque function does not support multi-start operations and therefore cannot be started when any other operation is in progress.
- ♦ During synchronous feeding torque operation, executing a deceleration stop causes an immediate stop.
- ♦ If the command torque exceeds the maximum torque that you set in the axis parameter settings, the command torque will be limited to the maximum speed.
- ♦ To execute the synchronous feeding torque function, you need PDO mappings. If you execute the synchronous feeding torque command for an axis without the require PDO mappings, the Insufficient PDO Allocation error occurs at startup.

Operations with the Synchronous Feeding Torque Command

This section describes operations you can perform with the synchronous feeding torque command, from the start to stop.

Procedure for Synchronous Feeding Torque Operation

Before executing the synchronous feeding torque command, you need to complete the settings related to the Synchronous Data Link function, as well as the allocations of the Direct Operation Command Memory Area and the Axis Status Memory Area.

Refer to *Direct Operation Command Memory Area* on page 6-91 for the Direct Operation Command Memory Area. Refer to *Axis Status Memory Area* on page 6-100 for the Axis Status Memory Area.

The following procedure assumes that allocations to these memory areas are already completed.

1. Synchronous Data Link Settings

Register the PCU as a synchronous unit and allocate the output area of synchronous feeding command torque data and velocity limitation data for each target axis of the synchronous feeding torque command.

2. Starting the Synchronous Data Link function

3. Putting the Servo Drive in operating status

4. Starting the synchronous feeding torque function

Turn ON the Synchronous Feeding Torque flag in the Direct Operation Command Memory Area. The Synchronous Feeding Torque Acknowledged Flag in the Axis Status Memory Area turns ON. The PCU is now ready to accept the synchronous feeding torque command.

5. Putting in synchronous feeding command torque data and velocity limitation data

Put a command torque as an absolute value in the Synchronous Command Torque Value output area of the Synchronous Data Link.

If you are also using the velocity limitation option function, put velocity limitation data in the velocity limitation data output area.

6. Stopping the synchronous feeding torque function

Turn OFF the Synchronous Feeding Torque flag in the Direct Operation Command Memory Area. The Axis Busy Flag turns OFF. The synchronous feeding torque command is now stopped.

Synchronous Feeding Torque Parameter Settings

Select whether to use the master axis as the target of the Synchronous Feeding Torque command and specify where in the Synchronous Data Link Memory Area the data to be output as the command torque is stored.

The Synchronous Feeding Torque Function Selection settings are continuously updated and applied when the Synchronous Feeding Torque command is executed.

Parameter name	Function	Setting range	Unit	Default value
Synchronous Feeding Torque Function Selection	Select whether to use the master axis as the target of the Synchronous Feeding Torque command. 0: Do not select. 1. Use the master axis as the target of Synchronous Data Link output.	0 to 1	–	0
Synchronous Feeding Torque Command Data Offset	Specify where the command data is stored as the relative position (number of words) to the first word of the Synchronous Data Link data to be output.	0 to Output Size Upper Limit - 2	–	0

Behavior of Deceleration Stop during Synchronous Feeding Torque Operation

During synchronous feeding torque operation, executing a deceleration stop works as an immediate stop.



Reference

- ♦ If you are creating a user program that uses a combination of the counter-slave feedback present position of the synchronous feeding torque function and that of the remote I/O to construct a full-closed control system, check carefully (by using the Synchronous Feeding Velocity Limitation function, for example) to ensure that it runs successfully. Then, move on to the actual production operation.
- ♦ Check the PCU Control Input Memory Area and the Communications Status Memory flag in the Remote I/O Communications Status Memory Area to take the appropriate action according to the status. Should you find an error, stop the processes that use input/output data or take other countermeasures.

Velocity Limitation Option Function

This section describes the Velocity Limitation Option settings for the synchronous feeding torque function.

Outline of Operation

While the Synchronous Feeding Torque flag in the Direct Operation Command Memory Area is ON, velocity limitation data is output to the memory area selected in the Synchronous Feeding Velocity Limitation Option settings.

The CPU Unit and PCU exchange data as shown below. Velocity limitation data always occupies two words.

If set to 0, it does not occupy the velocity limitation data area.

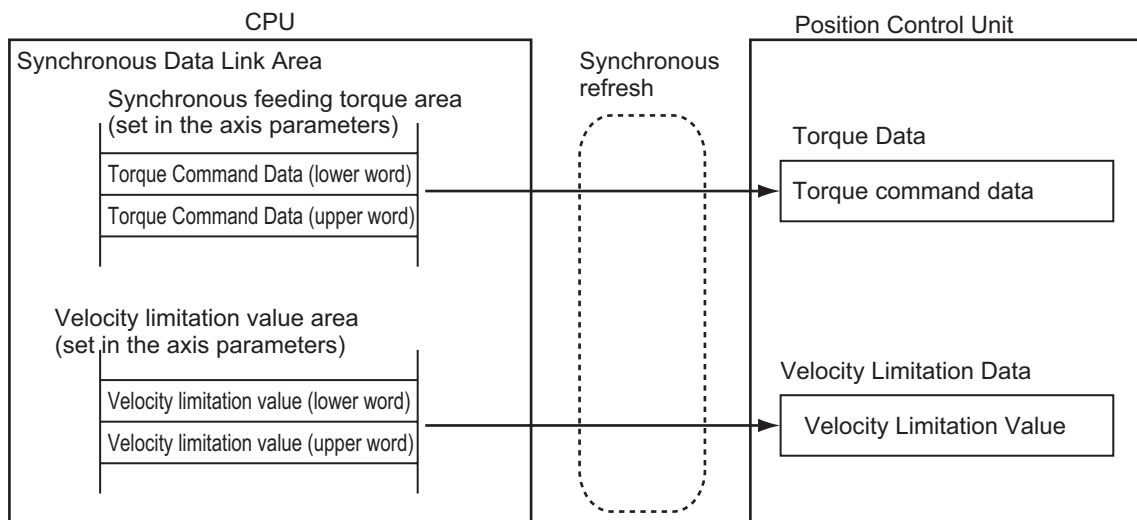

Precautions for Correct Use

To use the velocity limitation option function, you must complete the required Synchronous Data Link settings before executing the synchronous feeding torque command.

Velocity Limitation Option Parameter Settings

Select whether or not to use the Synchronous Feeding Velocity Limitation Option function and specify where in the Synchronous Data Link Memory Area the data to be output as the velocity limitation value is stored.

The Synchronous Feeding Velocity Limitation Option settings are continuously updated and applied when the Synchronous Feeding Torque command is executed.

Parameter name	Function	Setting range	Unit	Default value
Synchronous Feeding Velocity Limitation Selection	Select whether or not to use the optional Synchronous Feeding Velocity Limitation function. 0: Do not use the Synchronous Feeding Velocity Limitation function. 1: Use the Synchronous Feeding Velocity Limitation function.	0 to 1	–	0
Synchronous Feeding Velocity Limitation Value Offset	Specify where the command data is stored as the relative position (number of words) to the first word of the Synchronous Data Link data to be output.	0 to Output Size Upper Limit - 2	–	0

Velocity Limitation Data

You can specify the following data for the velocity limitation data.

Name	Bit	Function	Unit
Velocity Limitation Value	0 to 31	Specify the velocity limitation value. Setting range: 0 to maximum speed	Command units/s

12

Programming Examples

This section provides programming examples to perform linear interpolation control, circular interpolation control, origin searches, etc.

12-1 Outline of Programming Examples	12-1
12-2 Basic Programming Examples	12-4
12-3 Direct Operation.....	12-6
12-4 Memory Operation	12-11

12-1 Outline of Programming Examples

This section describes the settings to use a test system to check the operation of any of the programming examples which are given in this section.



Precautions for Correct Use

- ♦ The programming examples in this section consist only of ladder diagrams for the interface between the CPU Unit and PCU for using PCU functions.
- ♦ If you write a program for an actual system, add to the ladder diagrams which are shown in these programming examples any interlocks required for the machine movements, inputs/outputs from other devices, and other programming that is relates to control procedures, etc. Make sure that the program gives the intended operation commands to the PCU.
- ♦ Before you move on to the actual production operation, conduct thorough operation checks based on the user program that you created.

Devices To Be Used

You need at least the devices listed in the following table to perform positioning with the PCU.

Type	Remarks
PCU	CJ1W-NC281/ -NC481/ -NC881/ -NCF81/ -NC482/ -NC882/ -NCF82
SYSMAC CJ Series CPU Unit	CJ2H-CPU□□
Power Supply Unit	CJ1W-P□□□□
Servomotors and Servo Drives	Servomotors, Servo Drives, Cables between Servo Drive and Servomotor, and Cable between PCU and Servo Drives
24-VDC power supply	DC power supply
Software	CX-Programmer
Computer	You need a computer to use the CX-Programmer. (A separate cable is needed to connect to the CPU Unit.)

Position Control Unit

Use a CJ1W-NC281 2-axis PCU.

The programming examples in this section are created for a PCU that is set to unit number 2. The first word in the PCU Control I/O Memory Area is CIO 1550. Also, the PLC has only one PCU.

If you use a different unit number, change the word addresses in the PCU Control I/O Memory Area according to the following formula.

First word in PCU Control I/O Memory Area: $n = \text{CIO } 1500 + 25 \times \text{Unit number}$

Installation and Wiring

Install and wire the devices to be used according to *Section 3 Installation and Wiring*.

It is assumed that a 24-VDC power supply for control input and forward/reverse limit inputs are connected to the Servo Drive I/O signals.

To execute an origin search, also connect an origin proximity input.

Mechanical Configuration

Both axes conform to the mechanical configuration given in the following table.

Item name	Mechanical configuration
Motor to be used	Servomotor with Servo Drive
Motor's rated speed	3,000 r/min
Encoder resolution	2,000 pulses/rotation
Work travel distance per motor rotation	5 mm
Unit	mm, minimum unit = 0.01 mm
Maximum speed	250 mm/s (3,000 r/min)
Starting speed	0 mm/s (to use a Servomotor)
Acceleration time	0.1 s (fixed acceleration/deceleration rate)
Deceleration time	0.1 s (fixed acceleration/deceleration rate)

Parameter Settings

In these programming examples, set the common parameters, axis parameters, and memory operation parameters as described below.

These settings can be used for node addresses 1 to 4 when up to four axes are connected to an OMNUC G5-series Servo Drive. If more than four axes are corrected, set the first words so that the memory areas do not overlap.

Common Parameters

Set the operation I/O memory area allocation setting as given below.

For details on common parameters, refer to *6-3 Common Parameters* on page 6-15.

Manual Operation Command Memory Area Selection

Set W100 as the first word.

Direct Operation Command Memory Area Selection

Set W110 as the first word.

Memory Operation Command Memory Area Selection

Set W160 as the first word.

12-1 Outline of Programming Examples

Axis Status Memory Area Selection

Use W180 as the first word.

Memory Operation Status Memory Area Selection

Use W240 as the first word.

Axis Parameters

This section describes only the axis parameters that are required for the programming examples. For details, refer to 6-4 *Axis Parameters* on page 6-29.

Axis Type Setting

Set axes 1 and 2 as physical axes.

Command Position Unit Settings

Parameter name	Setting	Unit
Displayed Unit	mm ^{*1}	–
Command Pulses Count per Motor Rotation	2,000	Pulses
Work Travel Distance per Motor Rotation	5	mm
Unit Multiplier	x100 ^{*1}	–

*1. The position command unit will be 0.01 mm, and the speed command unit will be 0.01 mm/s for these settings.

Acceleration/Deceleration Settings

Use the same settings for both axes 1 and 2.

Parameter name	Setting	Unit
Maximum Speed	25,000	0.01mm/s
Starting Speed	0	0.01mm/s
Acceleration/Deceleration Curve Selection	Trapezoid	–
Acceleration/Deceleration Time Selection	Constant acceleration/ deceleration rate	–
Single-axis Deceleration Time at Interpolation	100	ms

Origin Search Settings

Parameter name	Setting	Unit
Origin Search Operation Mode	0 (Proximity Reverse Turn/ Origin Proximity OFF)	–
Origin Search Speed	10,000	0.01mm/s
Origin Search Approach Speed	1,000	0.01mm/s
Origin Search Acceleration Time	100	ms
Origin Search Deceleration Time	100	ms

12-2 Basic Programming Examples

The following example is the ladder programming for the basic functions of the PCU.



Precautions for Correct Use

- If you use these programming examples as reference, add appropriate interlocks according to the operating conditions of your system.

EtherCAT Communications Interlock

The following conditions must be met to operate the PCU Unit using a ladder program.

- PCU Ready Flag must be ON.
- The slaves (Servo Drives) to be operated are registered in the network configuration and process data communications has been correctly started already. (Bits corresponding to the normal slave table are ON.)
- There are no communications errors in the slaves to be operated (i.e., the corresponding flag in the Error Slave Table is OFF).

This programming example shows a command interlock for node 1 (axis 1) which corresponds to PCU unit number 0. If you use the following programming examples as reference, add interlocks for the relevant axes.

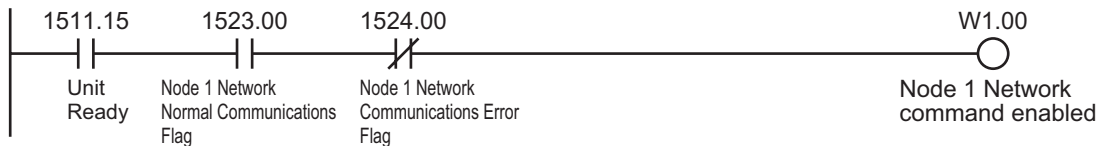

Servo Lock/Servo Unlock

This programming example locks and unlocks the servo for axis 1.

The Manual Operation Command Area Selection and Axis Status Memory Area Selection are set in the common parameters.

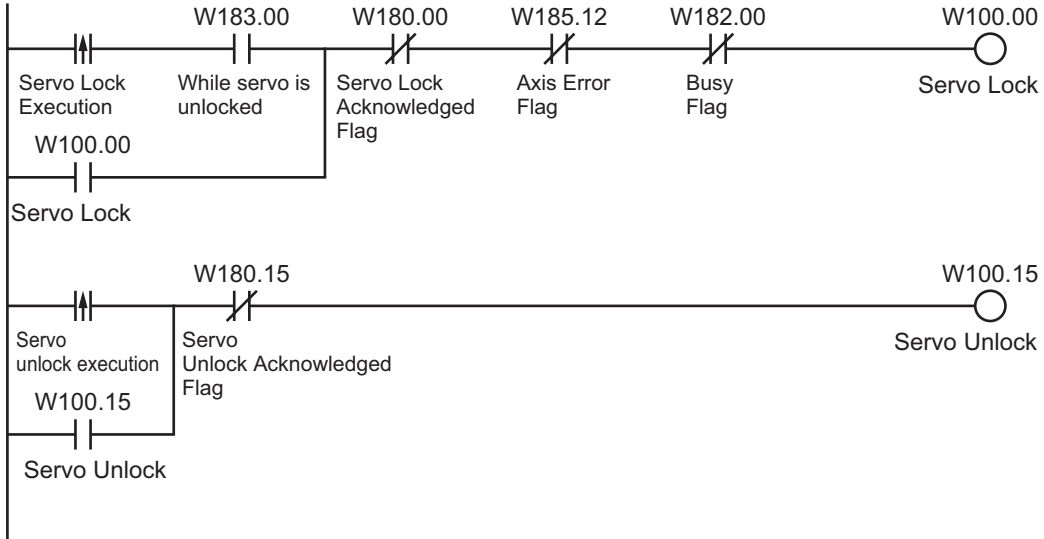

Origin Search

This programming example executes an origin search for axis 1.

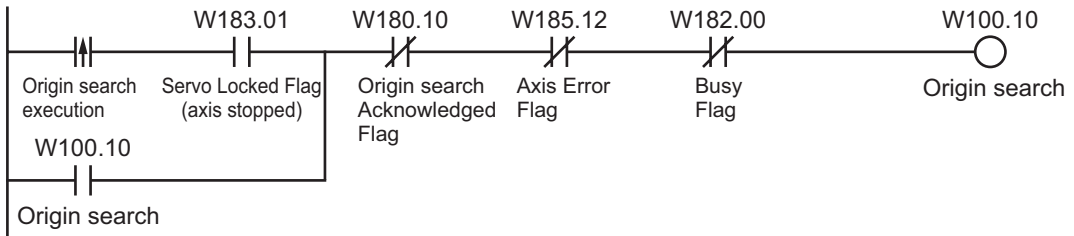

12-3 Direct Operation

The following programming example is for direct operation.



Precautions for Correct Use

- If you use these programming examples as reference, add appropriate interlocks according to the operating conditions of your system.

Positioning Using the DM Area

You can sequentially transfer the data in the DM Area via direct operation to perform a series of positioning operations. The axis executes positioning according to the command data that is set in the operation data area.

Whether the set position data is treated as absolute data or as incremental data depends on whether the Absolute Movement Bit or the Relative Movement Bit is used to start positioning.

Operation Example

The following is an example of positioning operation for an absolute movement based on position data in the DM area.

Define the origin by performing an origin search or present position preset in advance.

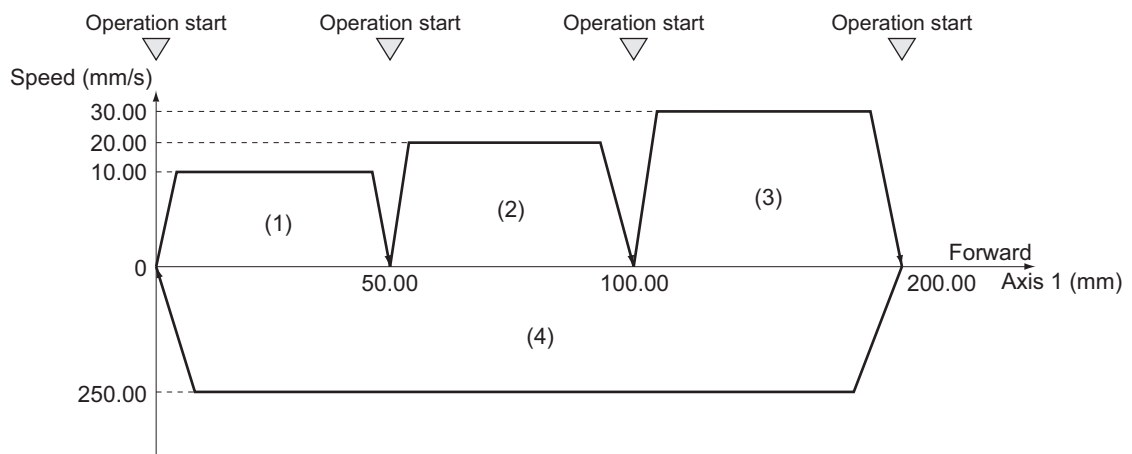

- 1) When you turn ON the operation start switch at the origin, axis 1 is positioned to 50.00 mm in the forward direction.
- 2) Thereafter, axis 1 is positioned to 100.00 mm, 200.00 mm, and finally returns to the origin and stops. The operation start switch must be turned ON once for each of these movements.

The acceleration time and deceleration time are both 0.1 s. Whether to use a fixed acceleration rate or a fixed time depends on the setting of the Acceleration/Deceleration Setting axis parameter. For details, refer to *Acceleration/Deceleration Settings* on page 6-36.

DM Area Settings

This programming example uses D00000 to D00019 in the DM Area. It sets the following position data in the Operation Output Memory Area.

DM area	Set value	Contents of setting
D00000	5000 (1388 hex)	Position command: 50.00 mm (position at 10 motor rotations)
D00001	0000 hex	
D00002	1000 (03E8 hex)	Command speed: 10.00 mm/s
D00003	0000 hex	
D00004	10000 (2710 hex)	Position command: 100.00 mm (position at 20 motor rotations)
D00005	0000 hex	
D00006	2000 (07D0 hex)	Command speed: 20.00 mm/s
D00007	0000 hex	
D00008	20000 (4E20 hex)	Position command: 200.00 mm (position at 40 motor rotations)
D00009	0000 hex	
D00010	3000 (0BB8 hex)	Command speed: 30.00 mm/s
D00011	0000 hex	
D00012	0000 hex	Position command: 0.00 mm
D00013	0000 hex	
D00014	25000 (61A8 hex)	Command speed: 250.00 mm/s
D00015	0000 hex	
D00016	0064 hex	Acceleration time: 100 ms
D00017	0000 hex	
D00018	0064 hex	Deceleration time: 100 ms
D00019	0000 hex	

Program Example

This programming example is executed while the Servomotor is servo locked.

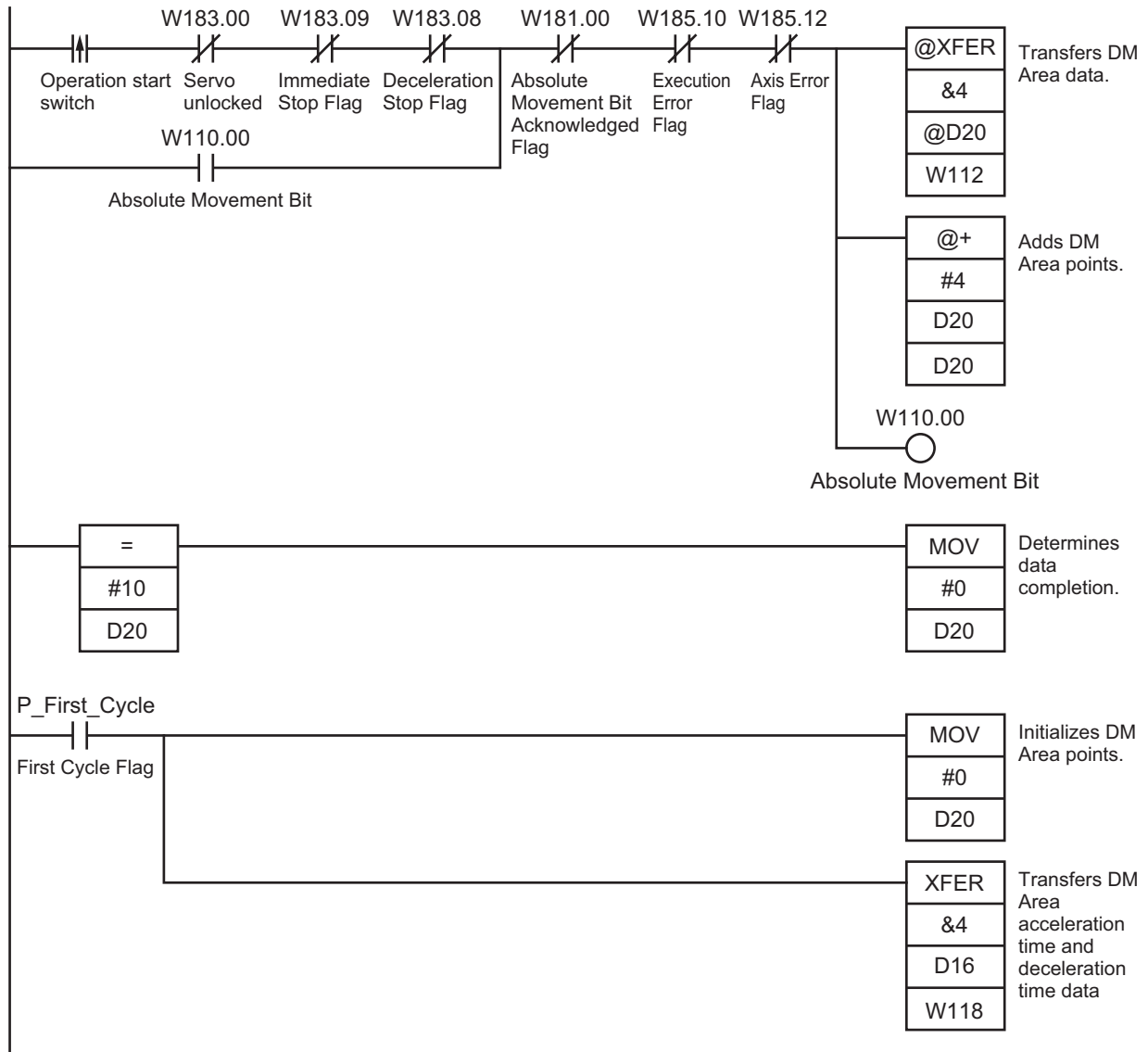

D00020 is used for indirect addressing.

For the settings of the memory areas for the Absolute Movement Bit and other bits and words, refer to *Parameter Settings* on page 12-2.

Speed Control

This programming example uses the Speed Control Bit in the Direct Operation Command Memory Area to execute speed control on the Servo Drive which is registered for axis 1.

Operation Example

The following operation example shows speed changes using speed control based on position data in the DM Area.

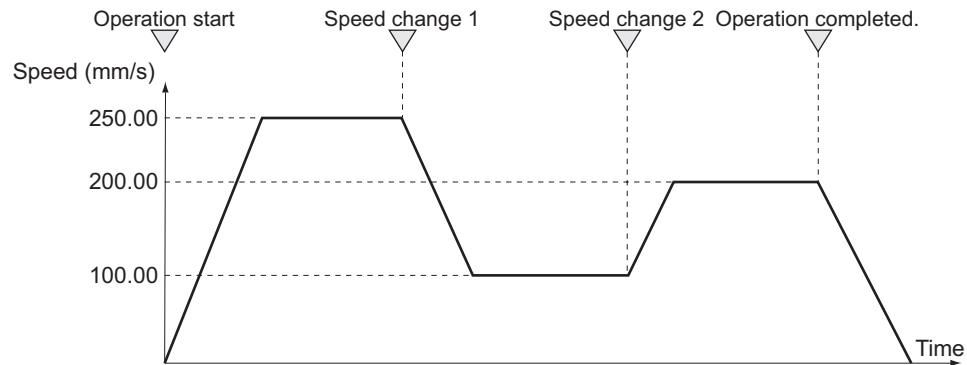

- 1) When you turn ON the operation start switch, speed control of axis 1 starts at 250.00 mm/s.
- 2) Thereafter, the speed of axis 1 changes to 100.00 mm/s and 200.00 mm/s every time you turn ON the operation start switch.
- 3) Finally, turn ON the operation stop switch to stop the Servomotor.

The acceleration time and deceleration time are both 0.1 s. Whether to use a fixed acceleration rate or a fixed time depends on the setting of the Acceleration/Deceleration Setting axis parameter. For details, refer to *Acceleration/Deceleration Settings* on page 6-36.

DM Area Settings

This programming example uses D00000 to D00019 in the DM Area. It sets the following position data in the Operation Output Memory Area.

DM area	Set value	Contents of setting
D00000	25000 (61A8 hex)	Command speed: 250.00 mm/s
D00001	0000 hex	
D00002	10000 (2710 hex)	Command speed: 100.00 mm/s
D00003	0000 hex	
D00004	20000 (4E20 hex)	Command speed: 200.00 mm/s
D00005	0000 hex	
D00006	0064 hex	Acceleration time: 100 ms
D00007	0000 hex	
D00008	0064 hex	Deceleration time: 100 ms
D00009	0000 hex	

Program Example

This programming example is executed while the Servomotor is servo locked.

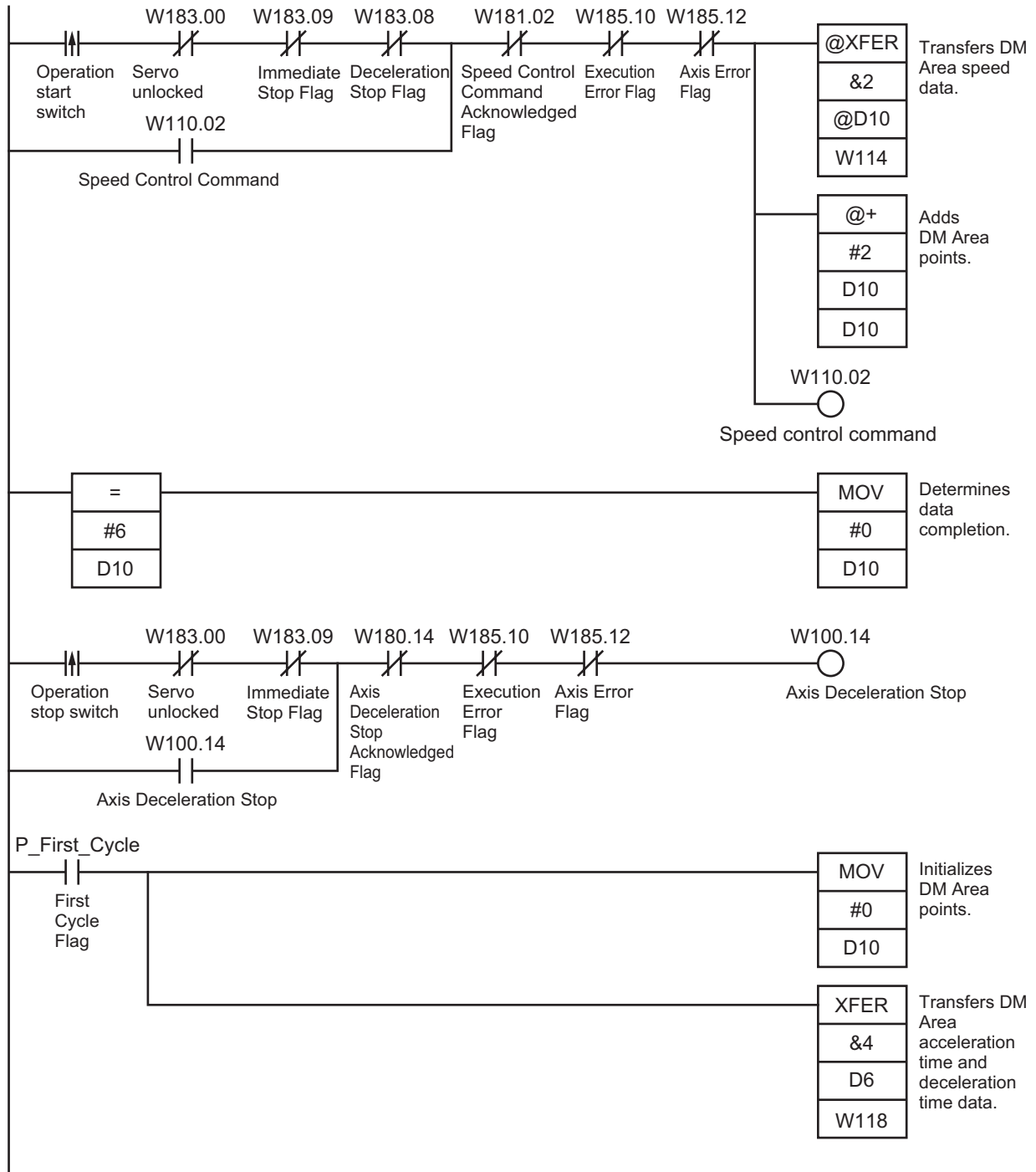

This programming example uses the Deceleration Stop Bit in the Manual Operation Command Memory Area to execute a deceleration stop on the Servo Drive which is registered for axis 1.

12-4 Memory Operation

The following programming examples are for memory operation.



Precautions for Correct Use

- ◆ If you use these programming examples as reference, add appropriate interlocks according to the operating conditions of your system.

Repeated Operation

You can use the END end pattern in memory operation to execute an operation repeatedly. When you set the end pattern for sequence data to END and execute a restart, the axis returns to the last effective sequence number to execute positioning.

Operation Example

The following is an example repeating the applicable operation.

Define the origin by performing an origin search or present position preset in advance.

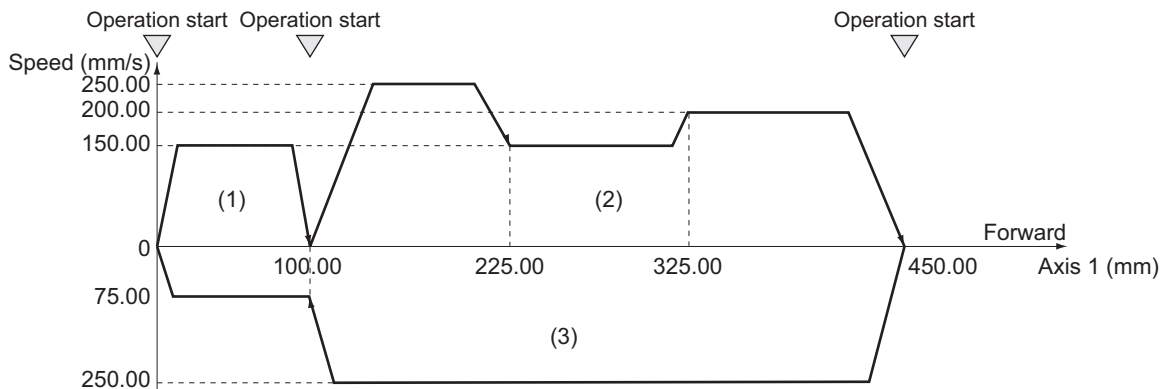

- 1) When you turn ON the operation start switch at the origin, axis 1 is positioned to 100.00 mm in the forward direction.
- 2) When you turn ON the operation start switch, axis 1 performs positioning for a continuous pattern and stops at 450.00 mm.
- 3) When you turn ON the operation start switch, axis 1 performs positioning for a continuous pattern, moves to the origin and stops.
- 4) When you turn ON the operation start switch, steps 1) to 3), above, are repeated.

Memory Operation Parameters

This section describes only the memory operation parameters that are required in the programming example. For details on common parameters, refer to *6-5 Memory Operation Parameters* on page 6-71.

Task Configuration Axis Setting

Parameter name	Setting	Unit
Configuration Axis	Use axis 1	–

Memory Operation Data Settings

To move the axis according to the operation example, set the following sequence data. Setting the *Axis Parameters* on page 12-3 specifies 0.01 mm as the command unit.

Sequence 1

Parameter name	Setting	Unit	Parameter name	Setting	Unit
Axis 1 Position Command	10000	Command units	M Code	No M code	–
Command	Linear interpolation operation	–	Axis Specification	Axis 1	–
Sequence Start Condition	No condition	–	Position Specification	Specify absolute position	–
Sequence Skip Condition	No condition	–	Axis 1 Command Speed	15000	Command units/s
End Pattern	Individual	–	Axis 1 Acceleration Time	100	ms
Positioning Completed Input Monitor Valid	Wait	–	Axis 1 Deceleration Time	100	ms
Dwell Timer	No dwell time	–			

Sequence 2

Parameter name	Setting	Unit	Parameter name	Setting	Unit
Axis 1 Position Command	22500	Command units	M Code	No M code	–
Command	Linear interpolation operation	–	Axis Specification	Axis 1	–
Sequence Start Condition	No condition	–	Position Specification	Specify absolute position	–
Sequence Skip Condition	No condition	–	Axis 1 Command Speed	25000	Command units/s
End Pattern	Continuous 1	–	Axis 1 Acceleration Time	100	ms
Positioning Completed Input Monitor Valid	Do not wait	–	Axis 1 Deceleration Time	100	ms
Dwell Timer	No dwell time	–			

Sequence 3

Parameter name	Setting	Unit	Parameter name	Setting	Unit
Axis 1 Position Command	32500	Command units	M Code	No M code	–
Command	Positioning operation	–	Axis Specification	Axis 1	–
Sequence Start Condition	No condition	–	Position Specification	Specify absolute position	–
Sequence Skip Condition	No condition	–	Axis 1 Command Speed	15000	Command units/s
End Pattern	Continuous 1	–	Axis 1 Acceleration Time	100	ms
Positioning Completed Input Monitor Valid	Do not wait	–	Axis 1 Deceleration Time	100	ms
Dwell Timer	No dwell time	–			

Sequence 4

Parameter name	Setting	Unit	Parameter name	Setting	Unit
Axis 1 Position Command	45000	Command units	M Code	No M code	–
Command	Positioning operation	–	Axis Specification	Axis 1	–
Sequence Start Condition	No condition	–	Position Specification	Specify absolute position	–
Sequence Skip Condition	No condition	–	Axis 1 Command Speed	20000	Command units/s
End Pattern	Individual	–	Axis 1 Acceleration Time	100	ms
Positioning Completed Input Monitor Valid	Wait	–	Axis 1 Deceleration Time	100	ms
Dwell Timer	No dwell time	–			

Sequence 5

Parameter name	Setting	Unit	Parameter name	Setting	Unit
Axis 1 Position Command	10000	Command units	M Code	No M code	–
Command	Linear interpolation operation	–	Axis Specification	Axis 1	–
Sequence Start Condition	No condition	–	Position Specification	Specify absolute position	–
Sequence Skip Condition	No condition	–	Axis 1 Command Speed	25000	Command units/s
End Pattern	Continuous 1	–	Axis 1 Acceleration Time	100	ms
Positioning Completed Input Monitor Valid	Do not wait	–	Axis 1 Deceleration Time	100	ms
Dwell Timer	No dwell time	–			

Sequence 6

Parameter name	Setting	Unit	Parameter name	Setting	Unit
Axis 1 Position Command	0	Command units	M Code	No M code	–
Command	Positioning operation	–	Axis Specification	Axis 1	–
Sequence Start Condition	No condition	–	Position Specification	Specify absolute position	–
Sequence Skip Condition	No condition	–	Axis 1 Command Speed	7500	Command units/s
End Pattern	Automatic	–	Axis 1 Acceleration Time	100	ms
Positioning Completed Input Monitor Valid	Wait	–	Axis 1 Deceleration Time	100	ms
Dwell Timer	No dwell time	–			

Sequence 7

Parameter name	Setting	Unit
Command	END	–
Sequence Start Condition	No condition	–

Program Example

This programming example is executed while the Servomotor is servo locked.

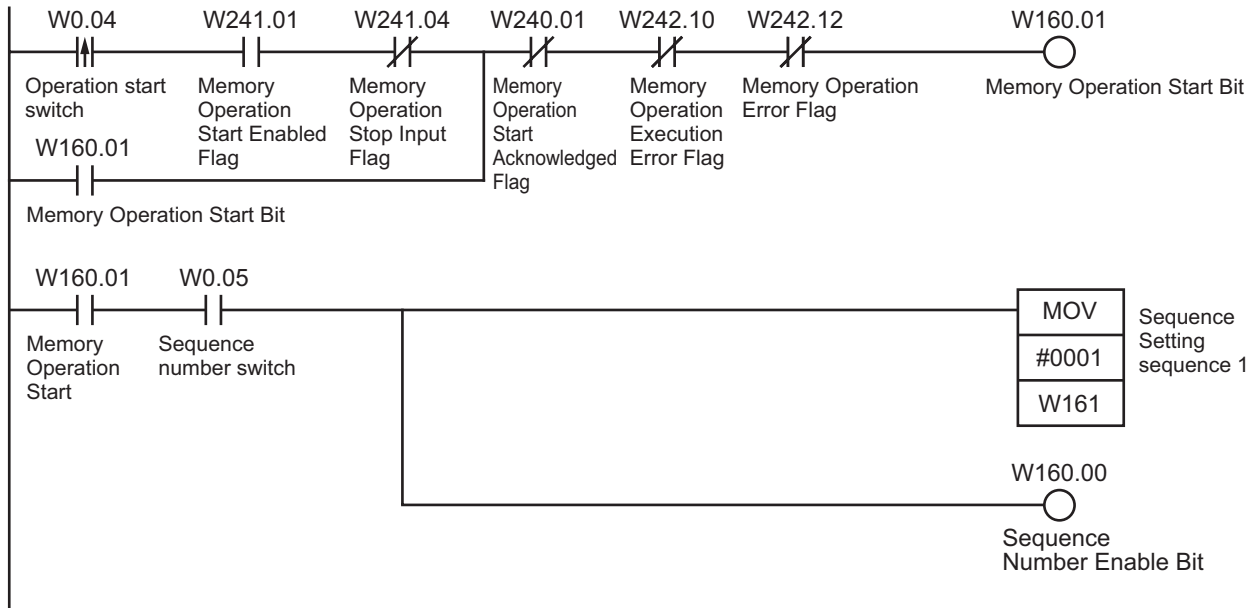

- 1) First, turn ON the sequence number setting switch.
- 2) Start the operation with the operation start switch.
- 3) Turn OFF the sequence number setting switch.
- 4) The axis is positioned every time you turn ON the operation start switch.

Turn ON the sequence number setting switch only once at the beginning.

Sequence 1 will be executed repeatedly unless you turn OFF the sequence number setting switch.

Linear Interpolation

This example uses two axes to perform positioning by linear interpolation.

Operation Example

The following is an example of operation that performs linear interpolation automatically and then returns to the origin and stops.

Define the origin by performing an origin search or present position preset in advance.

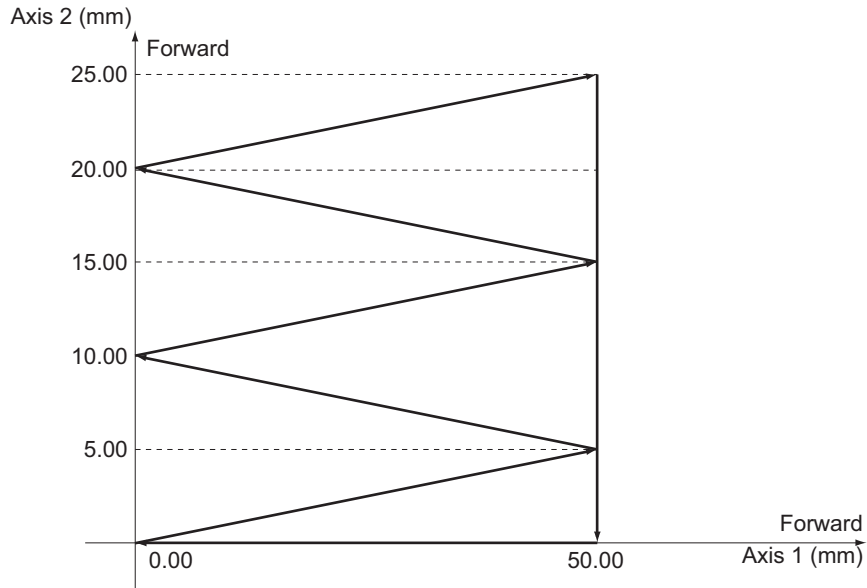

- 1) When you turn ON the operation start switch at the origin, the axes automatically perform positioning with linear interpolation in the following sequence and then stop:
 (Axis 1, Axis 2) = (50.00 mm,5.00 mm), (0 mm,10.00 mm), (50.00 mm,15.00 mm), (0 mm, 20.00 mm), (50.00 mm, 25.00 mm), (50.00 mm, 0 mm), and (0 mm, 0mm)

Here, the speed is 10.00 mm/s.

Memory Operation Parameters

This section describes only the memory operation parameters that are required in the programming example. For details, refer to 6-5 *Memory Operation Parameters* on page 6-71.

Configuration Axis

Parameter name	Setting	Unit
Configuration Axis	Use axis 1 and axis 2	—

Memory Operation Data Settings

To move the axis according to the operation example, set the following sequence data.
Setting the *Axis Parameters* on page 12-3 specifies 0.01 mm as the command unit.

Sequence 1

Parameter name	Setting	Unit	Parameter name	Setting	Unit
Axis 1 Position Command	5000	Command units	Axis Specification	Axis 1, axis 2	–
Axis 2 Position Command	500	Command units	Position Specification	Axis 1, axis 2 Specify absolute position	–
Command	Linear interpolation operation	–	Interpolation Speed	1000	Command units/s
Sequence Start Condition	No condition	–	Interpolation Acceleration Time	100	ms
Sequence Skip Condition	No condition	–	Interpolation Deceleration Time	100	ms
End Pattern	Automatic	–	Interpolation Starting Speed	0	Command units/s
Positioning Completed Input Monitor Valid	Wait	–	Interpolation Acceleration/Deceleration Curve Selection	Trapezoid	–
Dwell Timer	No dwell time	–	Interpolation Acceleration Time Selection	Up to maximum speed	–
M Code	No M code	–	Interpolation Speed Specification Method	Specify the interpolation path speed	–

Sequence 2

Parameter name	Setting	Unit	Parameter name	Setting	Unit
Axis 1 Position Command	0	Command units	Axis Specification	Axis 1, axis 2	–
Axis 2 Position Command	1000	Command units	Position Specification	Axis 1, axis 2 Specify absolute position	–
Command	Linear interpolation operation	–	Interpolation Speed	1000	Command units/s
Sequence Start Condition	No condition	–	Interpolation Acceleration Time	100	ms
Sequence Skip Condition	No condition	–	Interpolation Deceleration Time	100	ms
End Pattern	Automatic	–	Interpolation Starting Speed	0	Command units/s
Positioning Completed Input Monitor Valid	Wait	–	Interpolation Acceleration/Deceleration Curve Selection	Trapezoid	–
Dwell Timer	No dwell time	–	Interpolation Acceleration Time Selection	Up to maximum speed	–
M Code	No M code	–	Interpolation speed specification method	Specify the interpolation path speed	–

Sequence 3

Parameter name	Setting	Unit	Parameter name	Setting	Unit
Axis 1 Position Command	5000	Command units	Axis Specification	Axis 1, axis 2	–
Axis 2 Position Command	1500	Command units	Position Specification	Axis 1, axis 2 Specify absolute position	–
Command	Linear interpolation operation	–	Interpolation Speed	1000	Command units/s
Sequence Start Condition	No condition	–	Interpolation Acceleration Time	100	ms
Sequence Skip Condition	No condition	–	Interpolation Deceleration Time	100	ms
End Pattern	Automatic	–	Interpolation Starting Speed	0	Command units/s
Positioning Completed Input Monitor Valid	Wait	–	Interpolation Acceleration/Deceleration Curve Selection	Trapezoid	–
Dwell Timer	No dwell time	–	Interpolation Acceleration Time Selection	Up to maximum speed	–
M Code	No M code	–	Interpolation Speed Specification Method	Specify the interpolation path speed	–

Sequence 4

Parameter name	Setting	Unit	Parameter name	Setting	Unit
Axis 1 Position Command	0	Command units	Axis Specification	Axis 1, axis 2	–
Axis 2 Position Command	2000	Command units	Position Specification	Axis 1, axis 2 Specify absolute position	–
Command	Linear interpolation operation	–	Interpolation Speed	1000	Command units/s
Sequence Start Condition	No condition	–	Interpolation Acceleration Time	100	ms
Sequence Skip Condition	No condition	–	Interpolation Deceleration Time	100	ms
End Pattern	Automatic	–	Interpolation Starting Speed	0	Command units/s
Positioning Completed Input Monitor Valid	Wait	–	Interpolation Acceleration/Deceleration Curve Selection	Trapezoid	–
Dwell Timer	No dwell time	–	Interpolation Acceleration Time Selection	Up to maximum speed	–
M Code	No M code	–	Interpolation Speed Specification Method	Specify the interpolation path speed	–

Sequence 5

Parameter name	Setting	Unit	Parameter name	Setting	Unit
Axis 1 Position Command	5000	Command units	Axis Specification	Axis 1, axis 2	–
Axis 2 Position Command	2500	Command units	Position Specification	Axis 1, axis 2 Specify absolute position	–
Command	Linear interpolation operation	–	Interpolation Speed	1000	Command units/s
Sequence Start Condition	No condition	–	Interpolation Acceleration Time	100	ms
Sequence Skip Condition	No condition	–	Interpolation Deceleration Time	100	ms
End Pattern	Automatic	–	Interpolation Starting Speed	0	Command units/s
Positioning Completed Input Monitor Valid	Wait	–	Interpolation Acceleration/Deceleration Curve Selection	Trapezoid	–
Dwell Timer	No dwell time	–	Interpolation Acceleration Time Selection	Up to maximum speed	–
M Code	No M code	–	Interpolation Speed Specification Method	Specify the interpolation path speed	–

Sequence 6

Parameter name	Setting	Unit	Parameter name	Setting	Unit
Axis 2 Position Command	0	Command units	M Code	No M code	–
Command	Positioning operation	–	Axis Specification	Axis 2	–
Sequence Start Condition	No condition	–	Position Specification	Specify absolute position	–
Sequence Skip Condition	No condition	–	Axis 2 Command Speed	1000	Command units/s
End Pattern	Automatic	–	Axis 2 Acceleration Time	100	ms
Positioning Completed Input Monitor Valid	Wait	–	Axis 2 Deceleration Time	100	ms
Dwell Timer	No dwell time	–			

Sequence 7

Parameter name	Setting	Unit	Parameter name	Setting	Unit
Axis 1 Position Command	0	Command units	M Code	No M code	–
Command	Positioning operation	–	Axis Specification	Axis 1	–
Sequence Start Condition	No condition	–	Position Specification	Specify absolute position	–
Sequence Skip Condition	No condition	–	Axis 1 Command Speed	1000	Command units/s
End Pattern	Automatic	–	Axis 1 Acceleration Time	100	ms
Positioning Completed Input Monitor Valid	Wait	–	Axis 1 Deceleration Time	100	ms
Dwell Timer	No dwell time	–			

Sequence 8

Parameter name	Setting	Unit
Command	END	–
Sequence Start Condition	No condition	–

Program Example

This programming example is executed while the Servomotor is servo locked.

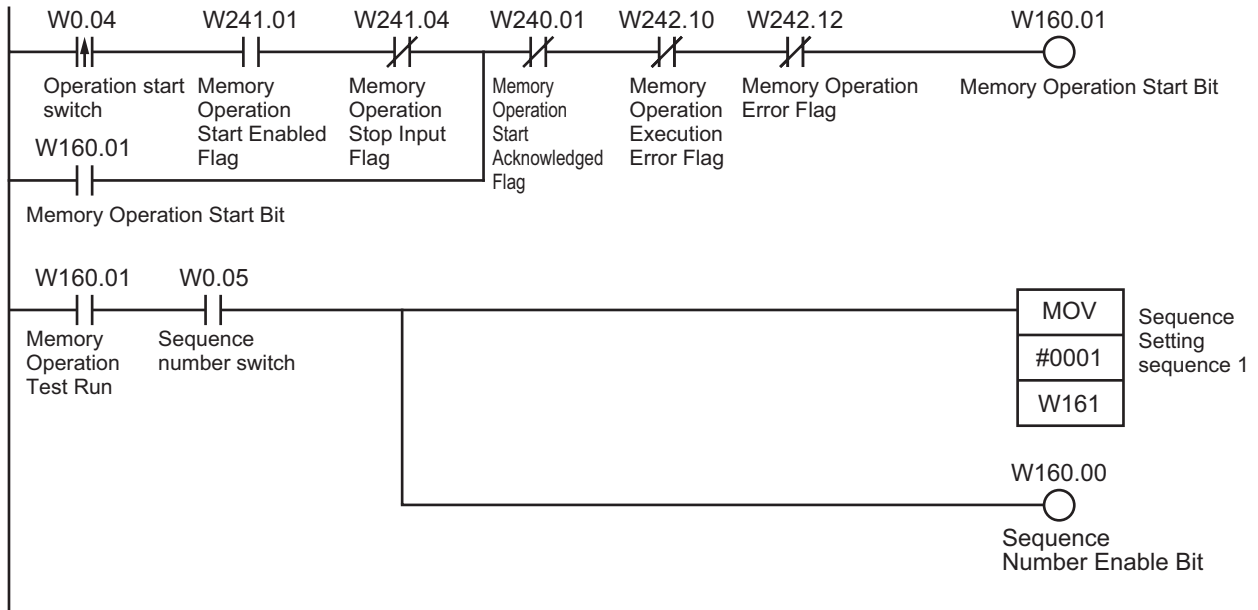

- 1) First, turn ON the sequence number setting switch to set sequence 1.
- 2) Start the operation with the operation start switch.

If you set the sequence number first and then turn ON the operation start switch, the axes will perform a series of positioning operations by linear interpolation.

Combination of Linear Interpolation and Circular Interpolation

Perform positioning based on a combination of linear interpolation and circular interpolation.

Operation Example

The following is an example of operation where the axes automatically performs positioning by using linear interpolation and circular interpolation.

Define the origin by performing an origin search or present position preset in advance.

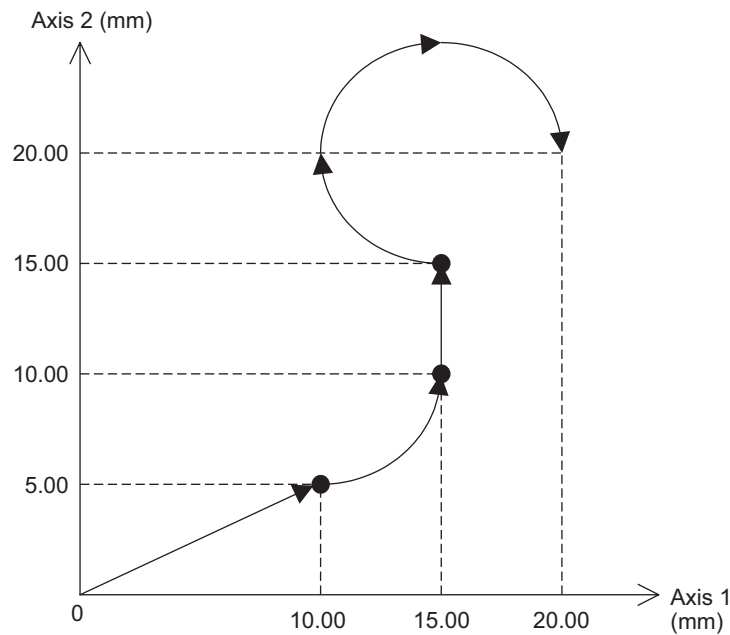

- 1) When you turn ON the operation start switch at the origin, the axes move to the point (10.00 mm, 5.00 mm) via linear interpolation. The axes continue to move to the point (15.00 mm, 10.00 mm) via circular interpolation, to the point (15.00 mm, 15.00 mm) via linear interpolation, and to the point (20.00 mm, 20.00 mm) via circular interpolation. Here, the speed is 10.00 mm/s.

Memory Operation Data Settings

To move the axis according to the operation example, set the following sequence data.
Setting the *Axis Parameters* specifies 0.01 mm as the command unit.

Sequence 1

Parameter name	Setting	Unit	Parameter name	Setting	Unit
Axis 1 Position Command	1000	Command units	Axis Specification	Axis 1, axis 2	–
Axis 2 Position Command	500	Command units	Position Specification	Axis 1, axis 2 Specify absolute position	–
Command	Linear interpolation operation	–	Interpolation Speed	1000	Command units/s
Sequence Start Condition	No condition	–	Interpolation Acceleration Time	100	ms
Sequence Skip Condition	No condition	–	Interpolation Deceleration Time	100	ms
End Pattern	Continuous 1	–	Interpolation Starting Speed	0	Command units/s
Positioning Completed Input Monitor Valid	Do not wait	–	Interpolation Acceleration/Deceleration Curve Selection	Trapezoid	–
Dwell Timer	No dwell time	–	Interpolation Acceleration Time Selection	Up to maximum speed	–
M Code	No M code	–	Interpolation Speed Specification Method	Specify the interpolation path speed	–

Sequence 2

Parameter name	Setting	Unit	Parameter name	Setting	Unit
Axis 1 Position Command	1500	Command units	Interpolation Speed	1000	Command units/s
Axis 2 Position Command	1000	Command units	Interpolation Acceleration Time	100	ms
Command	Linear interpolation operation	–	Interpolation Deceleration Time	100	ms
Sequence Start Condition	No condition	–	Interpolation Starting Speed	0	Command units/s
Sequence Skip Condition	No condition	–	Interpolation Acceleration/Deceleration Curve Selection	Trapezoid	–
End Pattern	Continuous 1	–	Interpolation Acceleration Time Selection	Up to maximum speed	–
Positioning Completed Input Monitor Valid	Do not wait	–	Axis 1 Circular Center/Passing Point Position	1000	Command units
Dwell Timer	No dwell time	–	Axis 2 Circular Center/Passing Point Position	1000	Command units
M Code	No M code	–	Circular radius	0	Command units
Axis Specification	Axis 1, axis 2	–	Circular interpolation method	Specify the circular center	–
Position Specification	Axis 1, axis 2 Specify absolute position	–			

Sequence 3

Parameter name	Setting	Unit	Parameter name	Setting	Unit
Axis 1 Position Command	1500	Command units	Axis Specification	Axis 1, axis 2	–
Axis 2 Position Command	1500	Command units	Position Specification	Axis 1, axis 2 Specify absolute position	–
Command	Linear interpolation operation	–	Interpolation Speed	1000	Command units/s
Sequence Start Condition	No condition	–	Interpolation Acceleration Time	100	ms
Sequence Skip Condition	No condition	–	Interpolation Deceleration Time	100	ms
End Pattern	Continuous 1	–	Interpolation Starting Speed	0	Command units/s
Positioning Completed Input Monitor Valid	Do not wait	–	Interpolation Acceleration/Deceleration Curve Selection	Trapezoid	–
Dwell Timer	No dwell time	–	Interpolation Acceleration Time Selection	Up to maximum speed	–
M Code	No M code	–	Interpolation Speed Specification Method	Specify the interpolation path speed	–

Sequence 4

Parameter name	Setting	Unit	Parameter name	Setting	Unit
Axis 1 Position Command	2000	Command units	Interpolation Speed	1000	Command units/s
Axis 2 Position Command	2000	Command units	Interpolation Acceleration Time	100	ms
Command	Circular interpolation (counterclockwise)	–	Interpolation Deceleration Time	100	ms
Sequence Start Condition	No condition	–	Interpolation Starting Speed	0	Command units/s
Sequence Skip Condition	No condition	–	Interpolation Acceleration/Deceleration Curve Selection	Trapezoid	–
End Pattern	Automatic	–	Interpolation Acceleration Time Selection	Up to maximum speed	–
Positioning Completed Input Monitor Valid	Wait	–	Axis 1 Circular Center/Passing Point Position	1500	Command units
Dwell Timer	No dwell time	–	Axis 2 Circular Center/Passing Point Position	2000	Command units
M Code	No M code	–	Circular Radius	0	Command units
Axis Specification	Axis 1, axis 2	–	Circular Interpolation Method	Specify the circular center	–
Position Specification	Axis 1, axis 2 Specify absolute position	–			

Sequence 5

Parameter name	Setting	Unit
Command	END	–
Sequence Start Condition	No condition	–

Program Example

This programming example is executed while the Servomotor is servo locked.

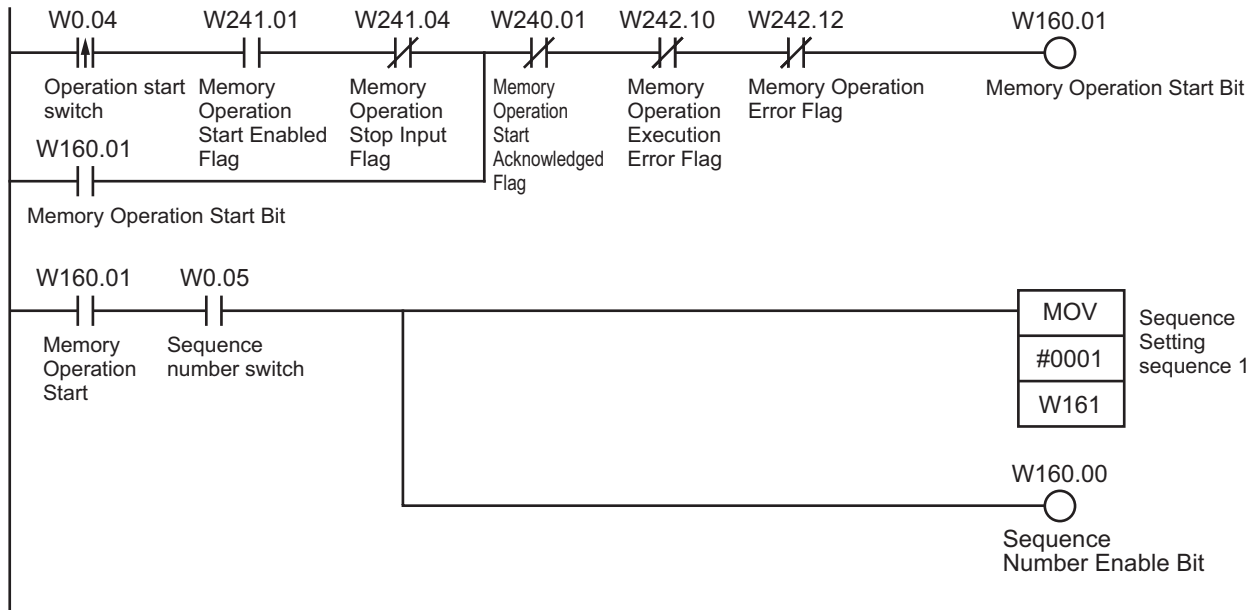

- 1) First, turn ON the sequence number setting switch to set sequence 1.
- 2) Start the operation with the operation start switch.

If you set the sequence number first and then turn ON the operation start switch, the axes will perform a series of positioning operations by linear interpolation and circular interpolation.

Tool Changer (Shortest Route Rotation Control)

When the Axis Feeding Mode is set to Rotation Axis, positioning is performed to the target position by automatically determining the shortest route, turning to the left or right.

For information on rotation axes, refer to *Command Position Unit Setting* on page 6-40.

Operation Example

Specify the target position in a range of 0° to 360°. The present position returns to 0° once it exceeds the range of 0° to 360°.

The following is an example of positioning operation for an absolute movement based on position data in the DM area.

Define the origin by performing an origin search or present position preset in advance.

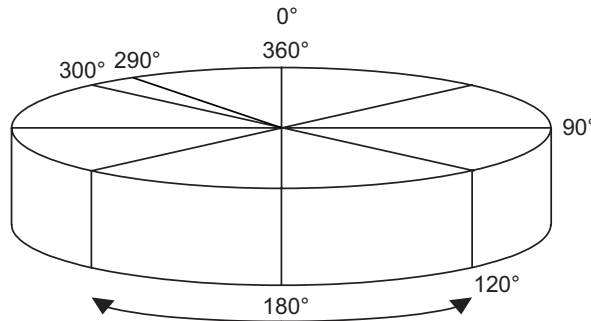

The shorter rotation direction is used for positioning.

- 1) When you specify any of the four positions, the origin (0°, 90°, 120°, 290°), and the axis moves to the specified position. The axis turns in the direction of the shortest route. The movement speed is 250°/s.

Axis Parameter Settings

Set the Axis Feeding Mode to Rotation Axis.

Command Position Unit Settings

Parameter name	Setting	Unit
Axis Feeding Mode	Rotation axis (infinite length)	—
Rotation Axis Upper Limit	359	°

Position Electronic Gear Settings

Parameter name	Setting	Unit
Displayed Unit	Degree	—
Command Pulses Count per Motor Rotation	2000	Pulses
Work Travel Distance per Motor Rotation	360	°
Unit Multiplier	x1	—

Memory Operation Data Settings

To move the axis according to the operation example, set the following sequence data.
With the *Axis Parameter Settings* on page 12-31, the command unit is degrees.

Sequence 1

Parameter name	Setting	Unit	Parameter name	Setting	Unit
Axis 1 Position Command	0	Command units	M Code	No M code	–
Command	Positioning operation	–	Axis Specification	Axis 1	–
Sequence Start Condition	No condition	–	Position Specification	Specify absolute position	–
Sequence Skip Condition	No condition	–	Axis 1 Rotation Axis Direction	With the shortest route	–
End Pattern	Individual	–	Axis 1 Command Speed	250	Command units/s
Positioning Completed Input Monitor Valid	Wait	–	Axis 1 Acceleration Time	100	ms
Dwell Timer	No dwell time	–	Axis 1 Deceleration Time	100	ms

Sequence 2

Parameter name	Setting	Unit	Parameter name	Setting	Unit
Axis 1 Position Command	90	Command units	M Code	No M code	–
Command	Positioning operation	–	Axis Specification	Axis 1	–
Sequence Start Condition	No condition	–	Position Specification	Specify absolute position	–
Sequence Skip Condition	No condition	–	Axis 1 Rotation Axis Direction	With the shortest route	–
End Pattern	Individual	–	Axis 1 Command Speed	250	Command units/s
Positioning Completed Input Monitor Valid	Wait	–	Axis 1 Acceleration Time	100	ms
Dwell Timer	No dwell time	–	Axis 1 Deceleration Time	100	ms

Sequence 3

Parameter name	Setting	Unit	Parameter name	Setting	Unit
Axis 1 Position Command	120	Command units	M Code	No M code	–
Command	Positioning operation	–	Axis Specification	Axis 1	–
Sequence Start Condition	No condition	–	Position Specification	Specify absolute position	–
Sequence Skip Condition	No condition	–	Axis 1 Rotation Axis Direction	With the shortest route	–
End Pattern	Individual	–	Axis 1 Command Speed	250	Command units/s
Positioning Completed Input Monitor Valid	Wait	–	Axis 1 Acceleration Time	100	ms
Dwell Timer	No dwell time	–	Axis 1 Deceleration Time	100	ms

Sequence 4

Parameter name	Setting	Unit	Parameter name	Setting	Unit
Axis 1 Position Command	290	Command units	M Code	No M code	–
Command	Positioning operation	–	Axis Specification	Axis 1	–
Sequence Start Condition	No condition	–	Position Specification	Specify absolute position	–
Sequence Skip Condition	No condition	–	Axis 1 Rotation Axis Direction	With the shortest route	–
End Pattern	Individual	–	Axis 1 Command Speed	250	Command units/s
Positioning Completed Input Monitor Valid	Wait	–	Axis 1 Acceleration Time	100	ms
Dwell Timer	No dwell time	–	Axis 1 Deceleration Time	100	ms

Sequence 5

Parameter name	Setting	Unit
Command	END	–
Sequence Start Condition	No condition	–

Program Example

This programming example is executed while the Servomotor is servo locked.

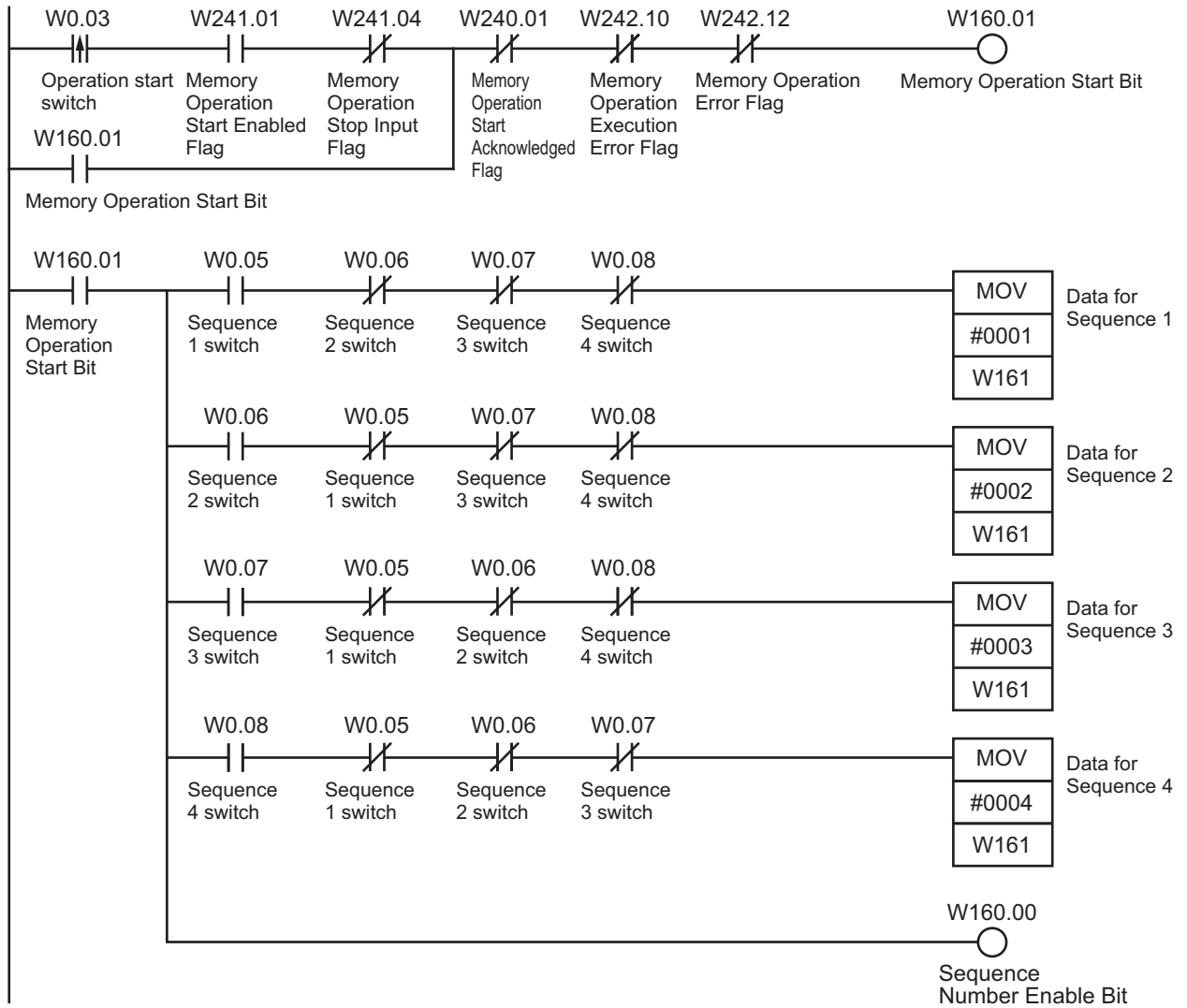

- 1) Turn ON the setting switch that corresponds to the sequence number for the desired operation angle.
- 2) The axis is positioned every time you turn ON the operation start switch.

13

Troubleshooting

This section describes the items to check when problems occur, error diagnosis and countermeasures for alarm indications, and error diagnosis and countermeasures for operating conditions.

13-1 Troubleshooting.....	13-1
13-2 Correcting Errors	13-9
13-3 Error Indicators	13-16
13-4 Error Flag Configuration	13-34
13-5 Reading Error Codes	13-38
13-6 Error Code List.....	13-40
13-7 Warnings and Overflows.....	13-54
13-8 Resetting Errors.....	13-55
13-9 Error Indications as a CPU Bus Unit.....	13-61

13-1 Troubleshooting

This section describes remedial actions to take when problems occur the first time you use the PCU or after starting PCU operation.

For descriptions of each error, refer to *13-2 Correcting Errors* on page 13-9 onward.

Preliminary Check Items

If you encountered a problem, check the items below to investigate the problem.

No.	Category	Item to check	Confirmed
1	Installation conditions	Is there dust around the PCU?	
2		Are there conductive foreign matters (metal, carbon, etc.) around the PCU that might enter the PCU?	
3		Is the ambient temperature higher than the ambient operating temperature in the specifications?	
4		Is the ambient area humid (due to moisture in the air, use of water, etc.)?	
5		Does the ambient air contain corrosive gases (acid, salt, sulfur, etc.)?	
6		Are there sources of noise around the PCU (welders, inverters, etc.)?	
7	Wiring	Are power supply lines wired in the same duct as the signal lines?	
8		Is the PCU grounded properly?	
9		Is there a noise filter in the power supply?	
10	Changes	Was any extension work (welding work) done lately?	
11		Was any power supply facility added lately?	
12		Was the system (including its program) modified in any way (including additions)?	
13	Accidents	Was there a lightning strike nearby?	
14		Was there a ground-fault accident or was the earth leakage breaker tripped?	
15		Was there a power outage?	

Troubleshooting Flowcharts

This section provides an initial troubleshooting flowchart and a troubleshooting flowchart for PCU operation.

Initial Troubleshooting Flowchart

Use this flowchart to troubleshoot the PCU when EtherCAT communications cannot be started normally or when commands from the PCU are not executed even though communications started normally.

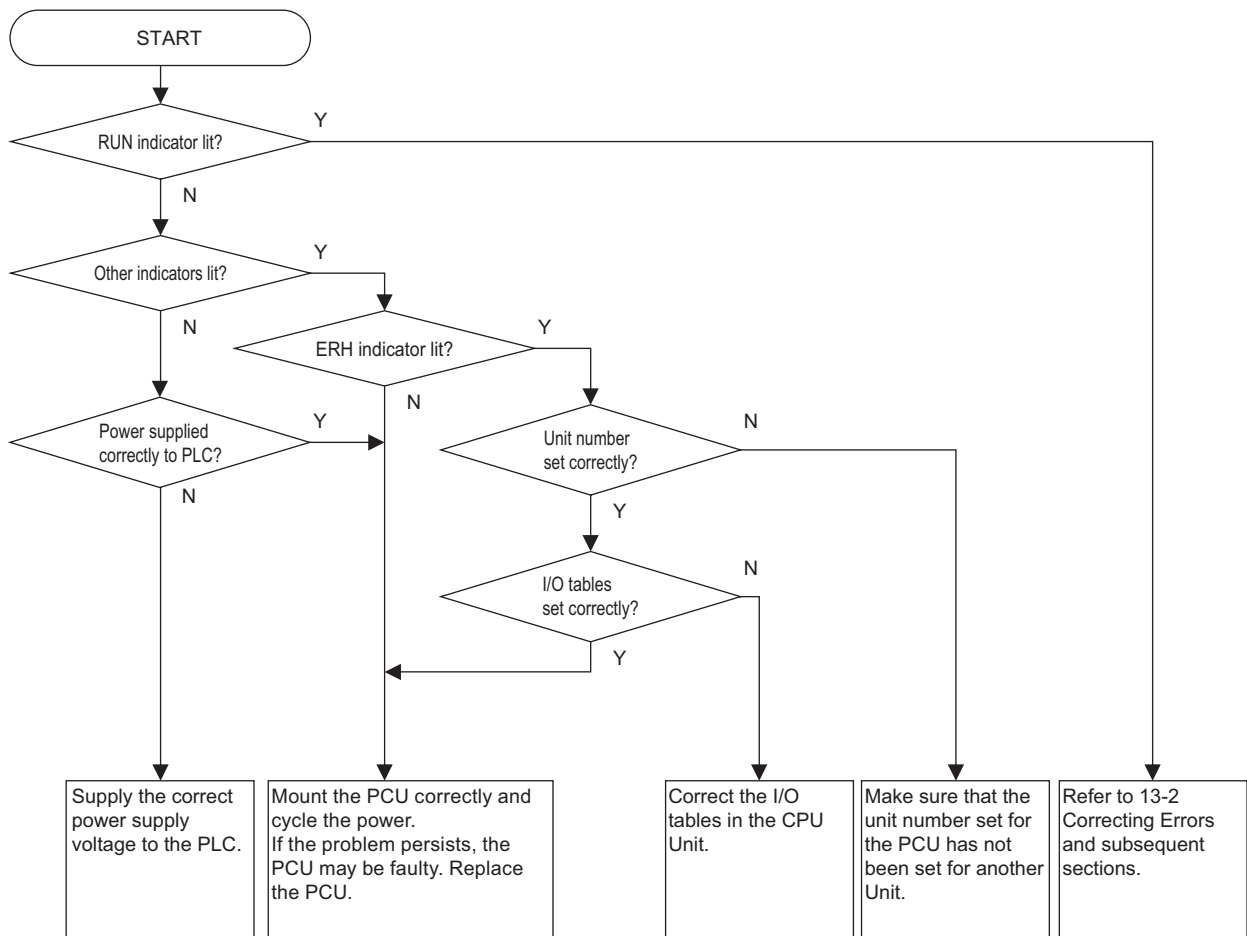

Troubleshooting Flowchart for PCU Operation

Use the following troubleshooting flowchart when problems occur after the PCU has started (i.e., after the RUN indicator has lit).

This flowchart will help you isolate the error to problems in the CPU Unit, problems with settings and application methods, or problems with EtherCAT communications.

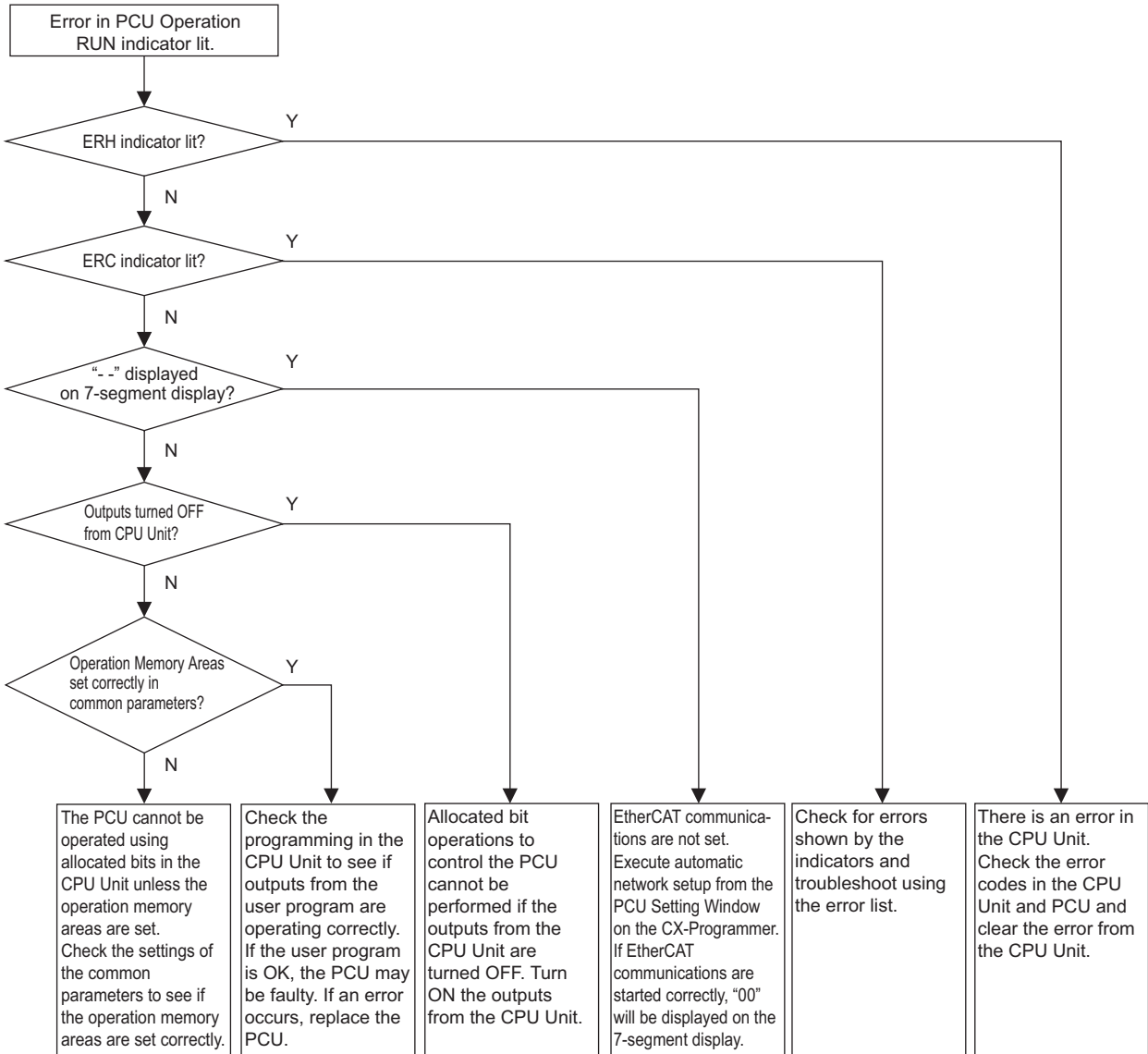

Problems and Countermeasures

This section describes troubleshooting when a PCU is used in combination with an OMNUC G5-series Servo Drive

If your system operates unexpectedly, the transferred parameters and memory operation data may not be saved in the flash memory. Also, data or flags may not be exchanged properly between the ladder program and PCU.

Use the data tracing function of CX-Programmer to check if data and flags are exchanged at the correct timings.

No.	Problem	Probable cause	Item to check	Countermeasure	Confirmed
1	The RUN indicator of the CPU Unit does not turn ON after you turn ON the power supply.	Incorrect wiring of the power supply line	Check the wiring of the power supply.	Wire correctly.	
2		Drop in power supply voltage	Check the voltage of the power supply.	Use the correct power supply. Check the power supply capacity.	
3		Faulty power supply capacity	—	Replace the power supply.	
4	Only the RUN indicator of the PCU does not turn ON after you turn ON the power supply.	Insufficient power supply capacity	Add up the power supply capacities of the CPU Units that are installed in the same system, as well as all other units, and compare the total power supply capacity against the power supply capacity of the Power Supply Unit. If the total power supply capacity exceeds the capacity of the Power supply Unit, you cannot use your system properly.	Increase the power supply capacity. Change the system configuration so that the power supply capacity is not exceeded.	
5		Failure	—	Perform the actions from <i>13-3 Error Indicators</i> on page 13-16 onward.	
6	Motor does not lock.	The PCU does not output operation commands to the Servo Drive.	Check if the ladder program is locking the servo.	Correct the ladder program.	
7		Servo Drive setting error	Check the Servo Drive settings.	Set the Servo Drive correctly.	
8	Motor does not run.	Motor is unlocked.	Refer to No. 6 and 7.	Refer to No. 6 and 7.	
9		The rotation prohibit input of the Servo Drive is enabled.	Use the Servo Drive software to check the rotation prohibit input.	Cancel the rotation prohibit input of the Servo Drive. Change the setting so that you do not use the rotation prohibit input of the Servo Drive.	
10		Servo Drive error	Check the error in the Servo Drive.	If there is an error, follow troubleshooting procedures for it.	
11		Mechanical axis is locked.	Check for contact with mechanical limits and check to see if mechanical parts are caught on something.	Manually release the locked mechanical axis.	
12		Faulty PCU	—	Replace the PCU.	

13-1 Troubleshooting

No.	Problem	Probable cause	Item to check	Countermeasure	Confirmed
13	Origin search cannot be performed.	Error	Check the nature of the error.	If there is an error, follow troubleshooting procedures for it.	
14		Incorrect wiring of the origin proximity input	Check if the origin proximity input sensor in the operation memory area turns ON/OFF.	Wire correctly.	
15		Incorrect wiring of the origin input	Check the wiring of the origin input.	Wire correctly.	
16		The rotation direction and limit input direction are inconsistent.	If the axis moves to the mechanical limit without reversing before the limit, check if the Limit Input Flag in the operation memory area turns ON and OFF.	Wire the limit input correctly.	
17		Incorrect wiring of the limit input	Check the wiring of the limit input.	Wire correctly.	
18		Positioning Operation Completed Flag does not turn ON.	Check if the Servo Drive gain is too low. Check if the positioning completed width is too narrow.	Increase the Servo Drive gain. Increase the positioning completed width.	
19		Origin search approach speed is too high	Check the origin search approach speed.	Lower the origin search approach speed of the PCU.	
20		Parameters are not set correctly.	Check the parameters with CX-Programmer.	Set the parameters correctly, transfer them to the PCU, and write the transferred parameters to the flash memory.	
21		Faulty PCU	—	Replace the PCU.	
22		Origin defined with an origin search changes occasionally.	Loose mechanical parts, such as couplings	Use a marker pen to mark the motor shafts, couplings, and other mechanical connections to check for shifting.	Securely tighten the connections that shifted.
23	Insufficient leeway for phase Z Insufficient leeway for origin input signal		If the value is close to the setting per Servomotor rotation (number of pulses per encoder rotation) or near zero, the origin may be shifted by one motor rotation due to slight changes timing of reading the sensor input.	Remove the motor coupling and shift the position by around one-quarter of a turn so that the phase-Z pulse occurs at around one half of a Servomotor rotation (number of pulses per encoder rotation), and then perform the origin search again.	

No.	Problem	Probable cause	Item to check	Countermeasure	Confirmed
24	Unstable motor rotation	Incorrect wiring of Servomotor power line/ encoder line, missing phase, etc.	Check the wiring of the motor power line and encoder line.	Wire correctly.	
25		Misalignment of the coupling that connects the motor shaft and the mechanical system Loose screw Fluctuation of load torque due to pulley and gear meshing	Check the machine. Turn the coupling under a no-load condition (with the mechanical part after the coupling removed).	Review and adjust the machine.	
26		Insufficient gain adjustment	—	Perform auto-tuning of the Servomotor. Manually adjust the Servomotor gain.	
27		Incorrect Servomotor selection (adjustment not possible)	Select another motor (check the torque and inertia ratio).	Change to an optimal motor.	
28		Damaged Servomotor bearings	Turn OFF the Servo Drive power supply, and also turn ON the brake power supply and release the brake if the motor comes with a brake. Then manually turn the motor output shaft with the motor power line disconnected (because the dynamic brake may be applied).	Replace the Servomotor.	
29	Broken Servomotor winding	Use a tester to check the resistance between phases U, V, and W of the motor power line. If the balance is off, there is a problem.	Replace the Servomotor.		
30	Rotation direction is reversed.	The Servo Drive is set to the opposite rotation direction.	Jog the machine. If the rotation direction of the Servo Drive is opposite the jogging direction, the rotation direction of the Servo Drive is reversed. Also check for reversed feedback signals (phases A and B) and reverse rotation setting of the parameter.	Set the rotation direction of the Servo Drive correctly.	
31	Rotation direction is reversed.	For Origin Search Inconsistency between the parameter that sets the origin proximity sensor polarity and the one that sets the origin proximity input polarity (in the PCU).	Check the parameter and sensor polarity again.	Set the correct parameters.	
32		For Origin Search Incorrect wiring of the origin proximity input	Check if the Origin Proximity Input Bit in the operation memory area turns ON/OFF.	Wire the origin proximity input correctly.	

No.	Problem	Probable cause	Item to check	Countermeasure	Confirmed
33	Operation cannot be started, positioning is not completed, or positioning takes too much time to complete.	The positioning completed width of the Servo Drive is too narrow, and thus the present position does not enter the positioning completed width. (The current operation does not complete until the present position enters the positioning completed width, so you cannot start the next position.)	—	Increase the positioning completed width of the Servo Drive.	
34		Servo Drive gain is low.	—	Adjust the Servo Drive gain.	
35		The axis does not remain in the positioning completed width due to an external force.	Check the deviation counter with the Servo Drive monitor function to see if the present position is inside the positioning completed width.	If you stop the axis so that a position inside the positioning completed width is not achieved, such as in push control, you can use the deviation counter reset output to forcibly achieve the positioning completed width.	
36	Abnormal noise	Mechanical vibration	Check the moving parts of the machine for intrusion of foreign matter, damage, deformation, and loosening.	Correct any problem.	
37		Insufficient adjustment of the Servo Drive gain (high gain)	—	Perform auto-tuning. Manually lower the gain.	
38		Incorrect motor selection (adjustment not possible)	Select another motor (check the torque and inertia ratio).	Change to an optimal motor.	
39		Misalignment of the coupling that connects the motor shaft and machine	—	Adjust the motor and machine installation.	
40	Motor shaft shakes.	Insufficient adjustment of the gain (low gain)	—	Perform auto-tuning. Manually increase the gain.	
41		Gain cannot be adjusted due to low machine rigidity.	In particular, this condition occurs on vertical axes, SCARA robots, palletizers, and other systems whose axis are subject o bending or tensional loads.	Increase the machine rigidity. Readjust the gain.	
42		Mechanical configuration prone to stick slip (highly sticky static friction)	—	Perform auto-tuning. Manually adjust the gain.	
43		Incorrect motor selection (adjustment not possible)	Select an appropriate motor (check the torque and inertia ratio).	Change to an optimal motor.	
44		Failure	—	Replace the Servo Drive. Replace the motor.	

No.	Problem	Probable cause	Item to check	Countermeasure	Confirmed
45	Position shift	The origin position was already shifted before positioning.	Refer to No. 22 and 23.	Refer to No. 22 and 23.	
46		Malfunction due to noise from a welder, inverter, etc.	Check if a welder, inverter, or other similar device is located nearby.	Isolate the PCU from any nearby welders, inverters, etc.	
47		Mechanical shift	Check if dimensional shifts accumulated (mark the mechanical connections to check for shifting).	Securely tighten the mechanical tightening points.	
48	Pausing and then restarting memory operation results in the operation starting from the beginning, not from the paused point.	The Sequence Number Enable Bit is ON when operation is restarted.	Check the ladder program or data tracing result.	To continue the operation from the paused point, turn OFF the Sequence Number Enable Bit when you restart operation.	

13-2 Correcting Errors

The PCU detects errors mainly at the following times.

Startup

The PCU checks the items in the following order when the power supply is turned ON, operation is restart, or the PCU Setup Bit is turned ON:

- ◆ Hardware check
- ◆ Establishing communications with the CPU Unit
- ◆ User parameters

If an error occurs, the error state is held. Check the method to clear the error and take the appropriate action.

If multiple errors occur, the PCU detects the next error as soon as you clear the present error. Repeat the clear operation to clear all errors.

If a Restore Error or a CPU But Unit Memory Error (User Data or Communications Parameters) occurs, commands except for those for data transfer (read and write) and data saving cannot be performed.

If other hardware errors or CPU communications errors occur, the PCU cannot operate unless the error is cleared and the power supply is turned OFF and ON again, or restarted.

Command Execution

The PCU checks for data problems, software limits, emergency stop signals, limit signals, etc., when a command is executed and during operation.

If an emergency stop or limit signal error is detected while another error is present, the PCU outputs the emergency stop and limit signal error. Check the method to clear the error and take the appropriate action.

Operation When an EtherCAT Communications Error Is Detected

When an EtherCAT communications error is detected, the PCU stops process data communications with the slave that generated the error or with all registered slaves, according to the setting of the Operation at Error Detection parameter in the Network Settings.

The communications process for each slave follows the setting of the Operation at Error Detection parameter as shown below.

Operation at Error Detection	Operation when an EtherCAT communications error is detected
Continue operation	<p>Process data communications with the slave that generated the error is stopped but continued with slaves that can continue communications. (Operational status continued.)</p> <p>With this setting, the bit corresponding to the node that generated the error will be turned ON in the Error Slave Table of the Unit Control Input Area, and an Axis Error (Axis Communications Error Code: 00A9) will be set in the Axis Status Memory Area.</p> <p>The flags for slaves for which process data communications is possible will be ON in the Normal Slave Table in the PCU Control Input Memory Area.</p>
Stop	<p>Stops process data communications with all slaves registered in the network configuration. Message communications is enabled (pre-operational status) for slaves that can perform EtherCAT communications.</p> <p>If this setting is used, the bit corresponding to the node where the error occurred will turn ON in the Error Slave Table in the PCU Control Input Memory Area and the PCU Control Input Memory Area will also show the cause of the error.</p> <p>The flags for slaves for which message communications is possible will be ON in the Slave Message Communications Enabled Table in the PCU Control Input Memory Area.</p>



Precautions for Correct Use

- If the Operation at Error Detection parameter is set to stop communications, process data communications will stop for all slaves when an EtherCAT communications error is detected in a slave. For this reason, if OMNUC G5-series Servo Drives are connected, all axis Servo Drives will be turned OFF. Make sure that the Operation at Error Detection parameter setting results in safe operation when a PCU error occurs.
- When the Operation at Error Detection parameter is set to stop operation, process data communications will be stopped to all slaves until the cause of errors are removed at all slaves. If even one error remains, process data communications will not be started even if the error reset operation is performed or the power supply is cycled.
If the Operation at Error Detection parameter is set to stop operation, remove the causes of any errors at all slaves and then perform the error reset operation.
- To reset the following OMNUC G5-series Servo Drive errors, the power supply to the Servo Drive must be cycled.
 - ♦ No. 14, 15, 18, 21, 23, 25, 27, 29, 33, 36, 37, 41, 43 to 45, 47 to 51, 55, 88, 92, 93, and 95 on the display on the front panel of the Servo Drive.

(Refer to the *OMNUC G5-series AC Servomotors/Servo Drives with Built-in EtherCAT Communications User's Manual* (Cat. No. I573) for information on errors.)

If the Servo Drive's control power supply is turned OFF, EtherCAT communications with Servo Drives (slaves) connected beyond that Servo Drive will be interrupted. Make sure that the PCU resumes safe operation by taking into account the effect when an error is reset by cycling the Servo Drive's power supply.

13-2 Correcting Errors

Operation	Operation flow	Refer to
Startup or restart	<pre> graph TD A[Power supply ON] -- Error detected --> C[Check wiring, PCU, and CPU Unit, and make corrections.] B[Hardware check] -- Error detected --> C D[Establishing communications with CPU Unit] -- Error detected --> C E[User parameter check] -- Error detected --> C A --> B B --> D D --> E C --> A </pre>	<p>13-3 Error Indicators on page 13-16 13-6 Error Code List on page 13-40</p>
Command Execution	<pre> graph TD F[Reception of start command] -- Error detected --> G[Correct wiring, data, or ladder program.] F --> H[Execution of start command] G --> F </pre>	

Dealing with Servo Drive Errors

When an OMNUC G5-series Servo Drive is connected, the PCU makes the following notifications about errors occurring in the Servo Drive.

Cause of Servo Drive error	Notification with PCU		
	PCU error (error code) ^{*1}	Axis error (error code)	Error Slave Table
Problems with EtherCAT communications	Slave Initialization Error (00A0) Network Configuration Verification Error (00A3) Slave AL Status Error (00A4) Process Data Communications Error (00A6)	Axis Communications Error (00A9)	The flag that corresponds to the node turns ON.
Problems with external control input • Main Circuit Power Supply Interrupted • Forward Drive Prohibition Input • Reverse Drive Prohibition Input • Emergency Stop Input	—	• Main Circuit OFF Error (5007) • Forward Limit Error (5008) • Reverse Limit Error (5009) • Emergency Stop Input (500D)	—
Other errors detected in the Servo Drive	—	Servo Drive Error Input (500F)	—

*1. If an EtherCAT communications error occurs in the Servo Drive, when the Operation at Error Detection parameter in the Network Settings is set to stop communications, a PCU error will be detected according to the control status at that time. If continuing operation is selected, only axis errors will be detected.

Dealing with Errors Related to EtherCAT Communications

When an EtherCAT communications error occurs in the Servo Drive, the PCU continues communications with the remaining slaves or stops communications with all slaves according to the setting of the Operation at Error Detection parameter.

If a communications error occurs, remove the cause of the error and turn ON the Error Reset Bit in the PCU Control Command Bits. Clear the PCU error by turning ON the Error Reset Bit and reestablish communications with the registered slaves for which communications were stopped.

Dealing with Errors Related to External Control Inputs

If there is an error with an external control input connected to the Servo Drive, or if the main power supply to the Servo Drive is interrupted, the PCU provides notification of an error corresponding to the input. If an error occurs, remove the cause of the error and then turn ON the Error Reset Bit in the PCU Control Command Bits.

Dealing with Other Errors Detected in the Servo Drive

If a Servo Drive Error Input Error (error code: 500F) occurs as an axis error, one of the following methods can be used to identify the error in the Servo Drive.

When the error in the Servo Drive has been identified, clear the error following instructions in the OMNUC G5-series Servo Drive User's Manual (Cat. No. I573), then turn ON the Error Reset Bit in the PCU Control Command Bits.

Reading Servo Drive Error Information with the CX-Drive

Connect the CX-Drive and check the Servo Drive information of the corresponding axis.

1. Start the CX-Programmer and connect with the PLC online. Start the PCU Setting Window.

Refer to Going Online from the *Going Online from the CX-Programmer* on page 1-13 and *Setting I/O Tables* on page 1-14 for the procedures to perform before starting the PCU Setting Window.

2. Right-click the Servo Drive with the error in the project tree in the PCU Setting Window. Select Start Special Tool Start with Settings Inherited and start the CX-Drive.

3. When the CX-Drive has started, select Status - Alarm from the workspace window and check the current error information.

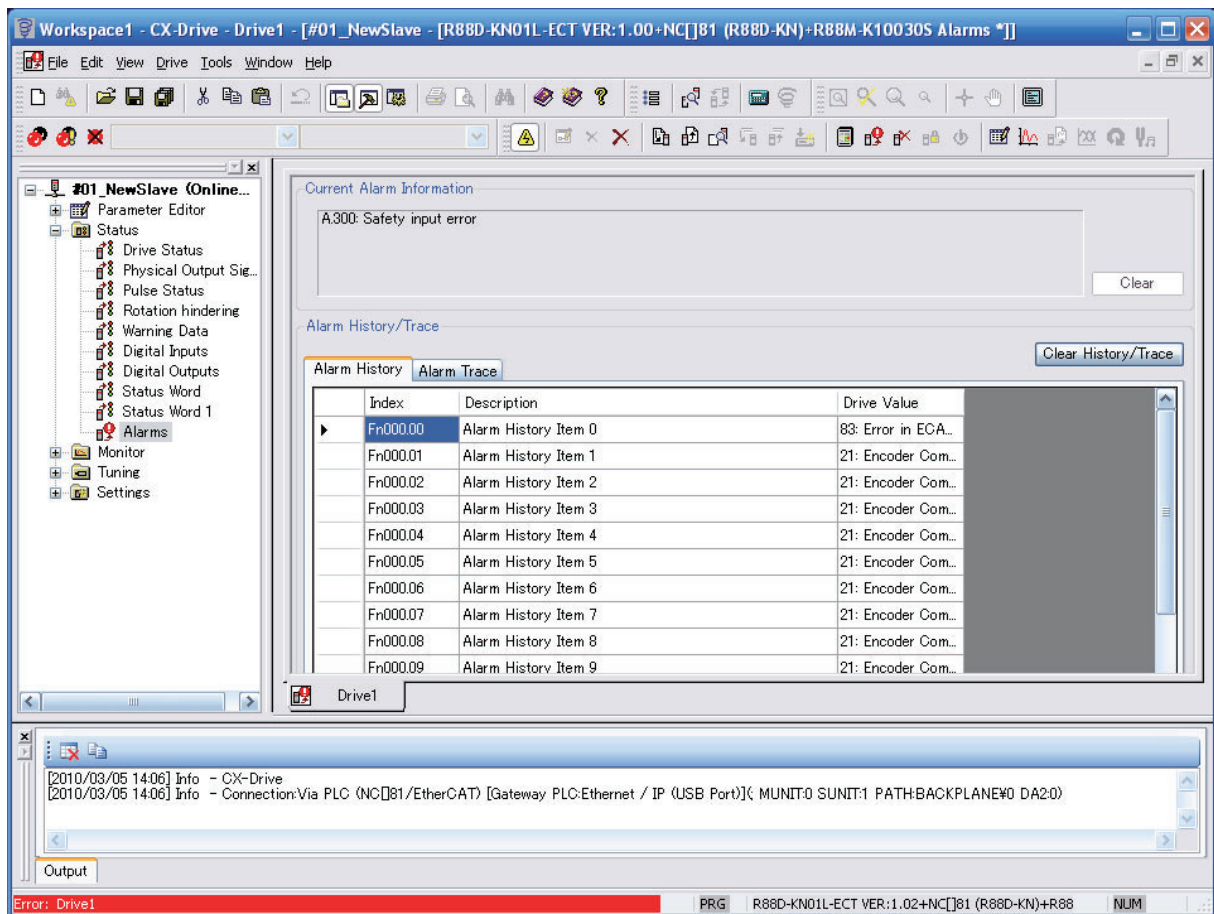

Reading Servo Drive Error Information with the Expanded Monitor

Select 9 (Slave Error Code) in the Expanded Monitor Settings of the Axis Parameter and check the error code from the Servo Drive.

The error code given in the Expanded Monitor will be for the following OMNUC G5-series Servo Drive drive profile. For details on the drive profile, refer to the *OMNUC G5-series Servo Drive User's Manual* (Cat. No. I573).

603F hex	Error Code						All
Setting range	0000 to FFFF hex	Unit	–	Default	0000 hex	Data attribute	–
Size	2 bytes (U16)		Access	RO	PDO mapping	Possible	

- ♦ The errors that are indicated are manufacturer-specific errors between FF00 and FFFF hex.
- ♦ The lower byte, FF00 to FFFF hex, indicates the main number of the error number.

Reading Servo Drive Error Information with the Read Data Bit

The above OMNUC G5-series Servo Drive error code is read using the slave parameter reading function with the Read Data Bit.

For an example of the ladder programming, refer to *Programming Example 2* on page 9-43.

Troubleshooting Errors That Occur When Connected to Remote I/O Slaves

When connecting slave devices other than OMNUC G5-series Servo Drives to the PCU, memory is directly allocated to the I/O of the connected devices for device control.

If this is the case, the PCU acts as a general communications master and performs only controls related to EtherCAT communications.

The device must be directly controlled using a user program via the allocated I/O memory bits.

For this reason, the following differences apply when connecting a G5-series Servo Drive and devices other than a G5-series Servo Drive.

Problems with communications

Connected device	Checking the error	Clearing the error
OMNUC G5-series Servo Drive	The Error Flag in the PCU Control Status is ON.	Reset the error in the PCU to recover.
Devices other than the G5-series Servo Drives	Same as above.	Same as above.

Errors Related to Slave Functions

Connected device	Checking the error	Clearing the error
OMNUC G5-series Servo Drive	Error Flags in the PCU Control Status and Axis Status turn ON.	Reset the error in the PCU to recover.
Devices other than the G5-series Servo Drives	Allocate the status information of the corresponding device in the input memory area and monitor the area to check the status.	Executing an error reset in the PCU will not clear the error status in the slave. Assign the control bits in the Output Memory Area and then use the Error Reset Bit in that area to recover from the error.



Reference

G5-series Servo Drives

Communications errors are treated as the PCU Control Status and an error reset can be executed from the PCU Control Output Memory Area.

Similarly, errors related to slaves (G5-series Servo Drives) are also treated as axis status. An error reset can be executed from the PCU Control Output Memory Area.

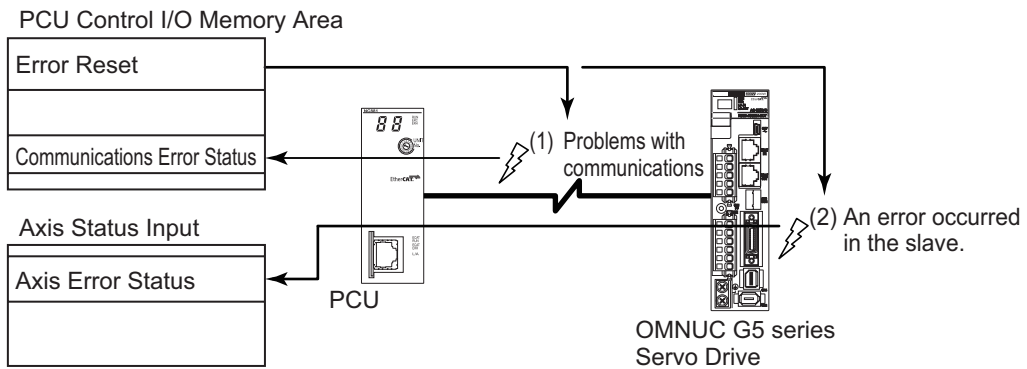

Devices Other than G5-series Servo Drives

Communications control is performed by using the PCU Control I/O Memory Area. I/O that is allocated to individual device functions are used to control them.

If a communications error occurs at the same time as a device error, an error reset operation must be executed from the PCU (clearing the communications error) after the device error is cleared using the allocated I/O bit.

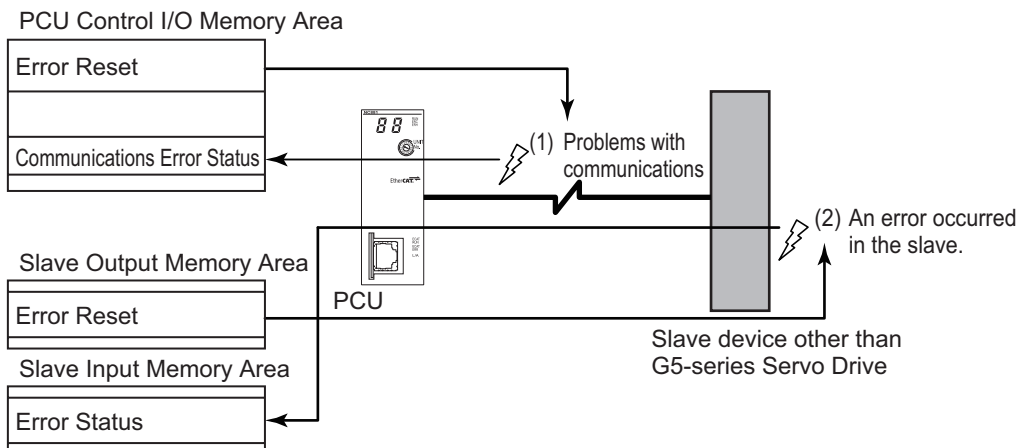

13-3 Error Indicators

The indicators on the front of the PCU indicate the following errors.

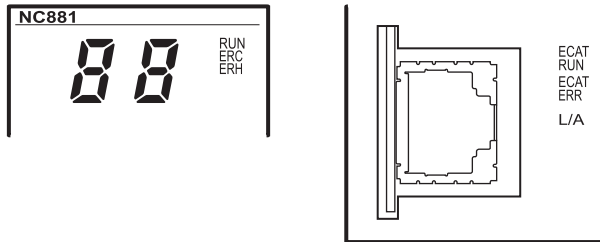

The indicators can operate in the following 6 ways.

ON	: ON
OFF	: OFF
F	: Flickering
B	: Blinking
SF	: Single flash
D	: Double flash

Note: Refer to 3-1 Part Names and Area Allocations on page 3-1 for the status of indicators other than "ON" and "OFF."

"Er," the error code, and the node address/axis number where the error occurred will be displayed on the 7-segment display when "xx + node address" or "xx + axis number" is specified in the 7SEG column.

Example: The following displays will appear when a slave AL status error occurs for the slave with node address 5 (7SEG column: "dd + node address").



If errors occur for more than one node or axis, they will be displayed in order from the start.



Reference

When synchronous data link is enabled on CJ1W-NC□82 PCU Ver.1.3 or later, the dot of first digit of 7-segment display flashes.



Indicator			ECAT		7SEG	Error name	Cause	Remedy
RUN	ERC	ERH	RUN	ERR				
OFF	OFF	OFF	—	—	—	CPU Unit Failure	Power is not supplied properly to the CPU Unit.	Remove the cause of the power failure and cycle the power supply.
						System Error	The PCU system is not operating properly.	Cycle the power supply or restart the PCU. If this error occurs again, replace the Unit. If this error occurs, the PCU turns OFF all outputs.

13-3 Error Indicators

Indicator			ECAT		7SEG	Error name	Cause	Remedy
RUN	ERC	ERH	RUN	ERR				
OFF	OFF	ON	-	-	H1	Invalid Unit Number Setting	An invalid unit number is set.	Change the unit number to a value inside the settable range, and then cycle the power supply.
						Duplicated Unit Number Setting	The unit number of the PCU is the same as that of other Unit.	
OFF	OFF	ON	-	-	Hb	CPU Unit Initialization Error	The initialization process in the CPU Unit was not successful.	Cycle the power supply and then create the I/O tables in the CPU Unit.
OFF	OFF	ON	-	-	H7	Other CPU Unit Errors	The PCU unit number is not registered in the I/O tables.	Cycle the power supply and then create the I/O tables in the CPU Unit.
OFF	OFF	ON	-	-	Y4	Synchronous Control Execution Not Enabled Error	Synchronous control could not be executed because the CJ2H CPU Unit's unit version is earlier than 1.3.	Use a CJ2H CPU Unit with supported unit version.
OFF	ON	OFF	-	-	H3	System Software Error	An error occurred in the PCU internal system ROM.	Cycle the power supply or restart the PCU. If this error occurs again, replace the Unit.
						Memory Error	An error occurred in the PCU internal memory.	
OFF	ON	ON	-	-	H3	PCU Type Error	The PCU is not recognized correctly.	Cycle the power supply or restart the PCU. If this error occurs again, replace the Unit.
OFF	ON	ON	-	-	Hb	CPU Unit Initialization Error	The initialization process in the CPU Unit was not successful.	Cycle the power supply or restart the PCU. If this error occurs again, replace the Unit.
ON	ON	OFF	-	-	H8	Restore Error	The easy backup function of the CPU Unit could not restore the backup data properly.	The PCU is using the data that was saved before the restore. Execute restore again, or transfer and save the data again. Only transferring and saving data can be performed until this error is cleared.
ON	ON	OFF	-	-	E9	CPU Bus Unit Memory Error (Error Log Data)	An error occurred in the nonvolatile memory that holds the error log of the PCU.	Clear the error log of the PCU, and then cycle the power supply or restart the PCU.
ON	ON	-	-	-	E9	CPU Bus Unit Memory Error (User Data) User Data/ Communications Parameters/Absolute Encoder Data (Absolute Encoder Data not applicable to unit version 1.3 or later)	User data could not be saved properly to the nonvolatile memory in the PCU. The saved user data is corrupted.	<ul style="list-style-type: none"> ♦ Transfer and save the data again. Only transferring and saving data can be performed until this error is cleared. If this error occurs again, replace the Unit. ♦ If this error occurs when you turn ON the power supply, all parameters and data in the PCU are reset to their default setting. ♦ If this error occurs, the PCU decelerates all axes to a stop.
ON	ON	-	-	B	E8	Setting Table Logic Error	The network configuration information is corrupted.	Download the setting file again.
OFF	ON	-	-	ON	H3	Hardware Error	An error was detected in the hardware test of the PCU.	Cycle the power supply or restart the PCU. If this error occurs again, replace the Unit.

Indicator			ECAT		7SEG	Error name	Cause	Remedy
RUN	ERC	ERH	RUN	ERR				
ON	ON	—	—	F	E1	Link OFF Error	An error occurred in establishing a link with a slave.	The cable connection may be bad. Reconnect or replace the cable. Once the cables are connected correctly, reset the error.
ON	ON	—	—	—	E9	Memory Access Error	A memory error occurred in the PCU.	Cycle the power supply or restart the PCU. If this error occurs again, replace the Unit.
ON	ON	—	—	D	db + node address (1 to 80)	Slave Initialization Error	Slave initialization failed.	<ul style="list-style-type: none"> • Correct the settings data and then download it again. • Cycle the power supply to the slave. • Replace the slave.
ON	ON	—	—	D	F0 + node address (1 to 80)	Duplicated Slave Node Address Error	The same node address is set for more than one slave.	Correct the duplicated node addresses and cycle the power supply.
ON	ON	—	—	D	dC	Network Configuration Error	The maximum number of nodes has been exceeded. The EtherCAT communications IN and OUT connections are incorrect.	<ul style="list-style-type: none"> • Review the network configuration and reduce the number of nodes. • Check the EtherCAT wiring and make sure that the connections are correct.
ON	ON	—	—	D	d5 + node address (1 to 80)	Network Configuration Verification Error	The network configuration that is defined in the network configuration information does not agree with the actual network configuration. Note: If a slave with a node address that is not included in the network configuration information is added, the 7-segment display will display d5 + 00.	<ul style="list-style-type: none"> • Review the network configuration. • Correct the settings data and then download it again. • Start any slaves that are not started. • Cycle the power supply to the slave. • Replace a slave.
ON	ON	—	—	SF	dd + node address (1 to 80)	Slave AL Status Error	An error has occurred in one or more slaves on the network.	Remove the cause of the error from the slave.
ON	ON	—	—	SF	FA	Frame Send Timing Error	The EtherCAT frame cannot be sent within the communications cycle.	Review the communications cycle.
ON	ON	—	—	SF	d9 + node address (1 to 80)	Process Data Communications Error	Process data could not be communicated properly.	<ul style="list-style-type: none"> • Review the communications cycle. • Check the cable connections and check for breaks in the cable.
ON	ON	—	—	SF	E2	Process Data Reception Timeout	The number of times the EtherCAT frame could not be received during the communications cycle exceeded the timeout detection count.	<ul style="list-style-type: none"> • Check the cable connections and check for breaks in the cable. • Check if there is any effect from external noise sources or from a ground fault. • Review the timeout detection count.

13-3 Error Indicators

Indicator			ECAT		7SEG	Error name	Cause	Remedy
RUN	ERC	ERH	RUN	ERR				
ON	ON	—	—	—	E9	CPU Bus Unit Memory Error (Communications Parameters)	The communications parameters could not be saved normally in nonvolatile memory in the PCU. Or, the communications parameters that were saved are corrupted.	<ul style="list-style-type: none"> Transfer and save the data again. Only transferring and saving data can be performed until this error is cleared. If this error occurs again, replace the Unit. If this error occurs when the power supply is turned ON, the communications parameters are not set in the PCU.
ON	ON	—	—	—	AE+ node address (1 to 80)	Axis Communications Error	A communications error occurred in the slave.	Remove the cause of the error from the slave and reset the error.
ON	ON	—	—	—	AE + Axis number (1 to 16)	Main Circuit OFF Error	The main circuits of the Servo Drive turned OFF while the servo was locked.	Check the main circuit power supply and reset the error.
						Emergency Stop Input	An emergency stop signal was input.	<ul style="list-style-type: none"> Cancel the emergency stop input and then execute an error reset. If the error cannot be reset, check the connection of the emergency stop signal and setting of the emergency stop input logic. If this error occurs, the PCU unlocks the servo for the applicable axis.
						Forward Limit Error	A forward limit signal was input.	<ul style="list-style-type: none"> Execute an error reset and then perform a recovery operation in the reverse direction. If a normal state cannot be recovered, check the connection of the forward limit signal and setting of the forward limit input logic. If this error occurs, the PCU stops the applicable axis according to the setting of the applicable axis parameter.
						Reverse Limit Error	A reverse limit signal was input.	<ul style="list-style-type: none"> Execute an error reset and then perform a recovery operation in the forward direction. If a normal state cannot be recovered, check the connection of the reverse limit signal and setting of the reverse limit input logic. If this error occurs, the PCU stops the applicable axis according to the setting of the applicable axis parameter.
						Servo Drive Alarm Input	A Servo Drive alarm was detected in the Servo Drive.	<ul style="list-style-type: none"> Remove the cause of the Servo Drive error and then execute an error reset. If this error occurs, the PCU unlocks the servo for the applicable axis.

Indicator			ECAT			7SEG	Error name	Cause	Remedy
RUN	ERC	ERH	RUN	ERR					
ON	ON	—	—	—	AE + Axis number (1 to 16)	Multi-start	Multiple functions that cannot be executed simultaneously were executed for the same axis.	<ul style="list-style-type: none"> • Check the execution conditions and then execute an error reset. • If this error occurs, the PCU decelerates the applicable axis to a stop. 	
						Servo Unlocked	An axis operation command was executed while the servo was unlocked.	Execute an error reset, and execute the axis operation command after the servo is locked.	
						Forward Limit Input	A forward start command was executed when a forward limit signal was being input.	Execute an error reset and then perform a recovery operation in the reverse direction. If this error occurs again, check the connection of the forward limit signal, setting of the forward limit input logic, and execution conditions for start command.	
						Reverse Limit Input	A reverse start command was executed when a reverse limit signal was being input.	Execute an error reset and then perform a recovery operation in the forward direction. If this error occurs again, check the connection of the reverse limit signal, setting of the reverse limit input logic, and execution conditions for start command.	
						Command Position Forward Software Limit Exceeded	The command position for positioning exceeds the software limit in the forward direction.	<ul style="list-style-type: none"> • Check the command position and software limit setting, and then execute an error reset. 	
						Command Position Reverse Software Limit Exceeded	The command position for positioning exceeds the software limit in the reverse direction.	<ul style="list-style-type: none"> • If this error occurs, the PCU decelerates the applicable axis to a stop. 	
						Present Position Unknown	An origin return was executed when the origin was undefined.	Execute an error reset, and execute the command after the origin is defined by executing an origin search or present position preset.	
						Deviation Counter Reset Error	An axis operation command was executed while a deviation counter reset signal was output. The deviation counter was reset during an origin search.	Check the execution conditions for deviation counter reset, and then execute an error reset. If this error occurs, the PCU decelerates the applicable axis to a stop.	
						Override Error	The override is out of range.	<ul style="list-style-type: none"> • Check the override set value and then execute an error reset. • If this error occurs, the PCU decelerates the applicable axis to a stop. 	
						Command Present Position Overflow	The command present position became greater than the upper limit (overflow) or smaller than the lower limit (underflow) of the usable range.	<ul style="list-style-type: none"> • Execute an error reset and then clear the overflow/underflow state by executing an origin search or present position preset. • If this error occurs, the PCU decelerates the applicable axis to a stop. 	

13-3 Error Indicators

Indicator			ECAT			7SEG	Error name	Cause	Remedy
RUN	ERC	ERH	RUN	ERR					
ON	ON	—	—	—	AE + Axis number (1 to 16)	Insufficient PDO Allocation	Synchronous feeding was started but the required process data was not mapped.	Check the process data mapping conditions for the start command. Use the Select By Support Function button in the Network Settings to add the required mappings, and then execute an error reset.	
						Positioning Timeout	The positioning completed input was not detected within the positioning monitor time.	Check the positioning completed input and then execute an error reset. If this error occurs again, check the connection of the positioning completed signal, input logic, and setting of the positioning monitor time.	
						Forward Software Limit Error	The software limit in the forward direction was exceeded.	<ul style="list-style-type: none"> Check the axis operation command and setting of the forward software limit, and then execute an error reset. If this error occurs, the PCU decelerates the applicable axis to a stop. 	
						Reverse Software Limit Error	The software limit in the reverse direction was exceeded.	<ul style="list-style-type: none"> Check the axis operation command and setting of the reverse software Limit, and then execute an error reset. If this error occurs, the PCU decelerates the applicable axis to a stop. 	
						Position Deviation Exceeded	The deviation between the command present position and present feedback position exceeded the set value.	<ul style="list-style-type: none"> Remove the cause of the deviation between the command present position and feedback present position, and then execute an error reset. If this error occurs, the PCU decelerates the applicable axis to a stop. 	
						Speed Deviation Overflow	The deviation between the present command speed and present feedback speed exceeded the set value.	<ul style="list-style-type: none"> Remove the cause of the deviation between the present command speed and present feedback speed, and then execute an error reset. If this error occurs, the PCU decelerates the applicable axis to a stop. 	
						Command Present Position Overflow	The command present position became greater than the upper limit (overflow) or smaller than the lower limit (underflow) of the usable range when the position and speed deviation monitor function was enabled.	<ul style="list-style-type: none"> Execute an error reset and then clear the overflow/underflow state by executing an origin search or present position preset. If this error occurs, the PCU decelerates the applicable axis to a stop. 	
						Feedback Present Position Overflow	The feedback present position became greater than the upper limit (overflow) or smaller than the lower limit (underflow) of the usable range when the position and speed deviation monitor function was enabled.	<ul style="list-style-type: none"> Execute an error reset, and then clear the overflow/underflow state by executing an feedback present position preset (IOWR(223) instruction). If this error occurs, the PCU decelerates the applicable axis to a stop. 	

Indicator			ECAT		7SEG	Error name	Cause	Remedy
RUN	ERC	ERH	RUN	ERR				
ON	ON	—	—	—	AE + Axis number (1 to 16)	Excessive Position Deviation	The deviation between the command present position and the feedback present position exceeded 30 bits, so processing could not be continued.	<ul style="list-style-type: none"> Remove the cause of the deviation between the command present position and the feedback present position and then reset the error. If this error occurs, the PCU stops the applicable axis according to the setting of the applicable axis parameter.
						Inching Command Position Overflow	The command present position became greater than the upper limit (overflow) or smaller than the lower limit (underflow) of the usable range during inching.	<ul style="list-style-type: none"> Remove the cause of the command present position overflow/underflow, check the inching width, and then execute an error reset. If this error occurs, the PCU decelerates the applicable axis to a stop.
						Absolute Encoder Present Position Restore Overflow	An overflow or underflow occurred in the feedback present position when the present position was calculated using data from the absolute encoder.	Reset the error, set up the absolute encoder again, and define the origin for the PCU.
						Origin Search Reverse Limit Error	The origin search operation was stopped due to detection of a limit input in the direction opposite the origin input detection direction.	<ul style="list-style-type: none"> Check the input signal for origin search and origin search setting, and then execute an error reset. If this error occurs, the PCU stops the applicable axis or decelerates to a stop according to the setting of the applicable axis parameter.
						Origin Search Direction Limit Error	The origin search operation was stopped due to detection of a limit input in the origin input detection direction.	
						Bidirectional Limit Error	The origin search cannot be continued because the limit inputs in both directions were detected.	
						Origin Proximity/ Origin Search Reverse Limit Error	The origin search operation was stopped because the origin proximity input and detection position of the limit input in the direction opposite the origin input detection direction were not appropriate.	
						Origin Proximity/ Origin Search Direction Limit Error	The origin search operation was stopped because the origin proximity input and detection position of the limit input in the origin input detection direction were not appropriate.	<ul style="list-style-type: none"> Check the origin proximity input and detection position of the limit input in the origin input detection direction, and then execute an error reset. If this error occurs, the PCU stops the applicable axis or decelerates to a stop according to the setting of the applicable axis parameter.

13-3 Error Indicators

Indicator			ECAT		7SEG	Error name	Cause	Remedy
RUN	ERC	ERH	RUN	ERR				
ON	ON	-	-	-	AE + Axis number (1 to 16)	Origin Input/Origin Search Reverse Limit Error	The origin search operation was stopped because the origin input and detection position of the limit input in the direction opposite the origin input detection direction were not appropriate.	<ul style="list-style-type: none"> Check the origin input and detection position of the limit input in the direction opposite the origin input detection direction, and then execute an error reset. If this error occurs, the PCU stops the applicable axis or decelerates to a stop according to the setting of the applicable axis parameter.
						Origin Input/Origin Search Direction Limit Error	The origin search operation was stopped because the origin input and detection position of the limit input in the origin input detection direction were not appropriate.	<ul style="list-style-type: none"> Check the origin input and detection position of the limit input in the origin input detection direction, and then execute an error reset. If this error occurs, the PCU stops the applicable axis or decelerates to a stop according to the setting of the applicable axis parameter.
						Origin Input Mask Amount Invalid	The set value of the origin input mask amount is insufficient for the amount of movement that you need to decelerate from the origin search speed to the origin search approach speed, when the Origin Search Operation Mode is set to Proximity Reverse Turn/Origin Input Mask Amount.	<ul style="list-style-type: none"> Check the origin input mask amount, origin search speed and origin search approach speed, and then execute an error reset. If this error occurs, the PCU decelerates the applicable axis to a stop.
						No Origin Input	The origin input was not detected during an origin search.	<ul style="list-style-type: none"> Check the connection and setting of the origin proximity input, and then execute an error reset. If this error occurs (upon limit input), the PCU stops the applicable axis according to the setting of the applicable axis parameter.
						No Origin Proximity Input	The origin proximity input was not detected in an origin search operation that uses the origin proximity input.	<ul style="list-style-type: none"> Check the connection and setting of the origin input, and then execute an error reset. If this error occurs (upon limit input), the PCU stops the applicable axis according to the setting of the applicable axis parameter.
						Origin Input Mask Position Overflow	The command present position became greater than the upper limit (overflow) or smaller than the lower limit (underflow) of the usable range due to the movement by the origin input mask amount, when the Origin Search Operation Mode was set to Proximity Reverse Turn/Origin Input Mask Amount.	<ul style="list-style-type: none"> Check the setting of the origin input mask amount and range of the command present positions used, and then execute an error reset. If this error occurs, the PCU decelerates the applicable axis to a stop.

Indicator			ECAT		7SEG	Error name	Cause	Remedy
RUN	ERC	ERH	RUN	ERR				
ON	ON	—	—	—	AE + Axis number (1 to 16)	Absolute Encoder Origin Position Offset Overflow	When you use an absolute encoder, the absolute encoder origin position offset that was calculated upon completion of the origin search exceeded the setting range.	Set up the absolute encoder again, and then execute an error reset.
						Absolute Encoder Origin Position Offset Calculation Not Possible	When you use an absolute encoder, the feedback present position became greater than the upper limit (overflow) or smaller than the lower limit (underflow) of the usable range during the origin search.	<ul style="list-style-type: none"> Check the unit setting for feedback pulse input and range of feedback present positions, and then execute an error reset. If this error occurs, the PCU decelerates the applicable axis to a stop.
						Absolute Movement Position Error	The command position of absolute movement is outside the specified range.	<ul style="list-style-type: none"> Check the set value of the command position and then execute an error reset. If this error occurs, the PCU decelerates the applicable axis to a stop.
						Absolute Movement Speed Error	The command speed of absolute movement is outside the specified range.	<ul style="list-style-type: none"> Check the set value of the command speed and then execute an error reset. If this error occurs, the PCU decelerates the applicable axis to a stop.
						Absolute Movement Acceleration Time Error	The acceleration time of absolute movement is outside the specified range.	<ul style="list-style-type: none"> Check the set value of the acceleration time and then execute an error reset. If this error occurs, the PCU decelerates the applicable axis to a stop.
						Absolute Movement Deceleration Time Error	The deceleration time of absolute movement is outside the specified range.	<ul style="list-style-type: none"> Check the set value of the deceleration time and then execute an error reset. If this error occurs, the PCU decelerates the applicable axis to a stop.
						Absolute Movement Direction Specification Error	The rotational axis direction setting of absolute movement is outside the specified range.	<ul style="list-style-type: none"> Check the setting of the rotational axis direction, and then execute an error reset. If this error occurs, the PCU decelerates the applicable axis to a stop.
						Rotation Axis Upper Limit Exceeded	The command position of absolute movement for a rotation axis exceeds the rotation axis upper limit.	<ul style="list-style-type: none"> Check the set value of the command position and then execute an error reset. If this error occurs, the PCU decelerates the applicable axis to a stop.
						Absolute Movement Interrupt Feeding Position Error	The command position of absolute movement interrupt feeding is outside the specified range. The command position resulted in 0 movement, and thus the feeding direction was not determined upon interrupt input.	<ul style="list-style-type: none"> Check the set value of the command position and then execute an error reset. If this error occurs, the PCU decelerates the applicable axis to a stop.

13-3 Error Indicators

Indicator			ECAT		7SEG	Error name	Cause	Remedy
RUN	ERC	ERH	RUN	ERR				
ON	ON	—	—	—	AE + Axis number (1 to 16)	Absolute Movement Interrupt Feeding Input Function Setting Error	Interrupt feeding cannot be executed because a latch input is selected for the interrupt input function.	Check the setting of the interrupt input function, and then execute an error reset.
						Absolute Movement Interrupt Feeding with No Interrupt Signal	An interrupt input signal was not detected during interrupt feeding.	Check the connection and setting of the interrupt input, and then execute an error reset.
						Absolute Movement Interrupt Feeding Feedback Present Position Overflow	An overflow or underflow occurred in the feedback present position for an interrupt input.	<ul style="list-style-type: none"> Execute an error reset, and then clear the overflow/underflow state by executing an feedback present position preset (IOWR(223) instruction). If this error occurs, the PCU decelerates the applicable axis to a stop.
						Relative Movement Position Error	The command position of relative movement is outside the specified range.	<ul style="list-style-type: none"> Check the set value of the command position and then execute an error reset. If this error occurs, the PCU decelerates the applicable axis to a stop.
						Relative Movement Speed Error	The command speed of relative movement is outside the specified range.	<ul style="list-style-type: none"> Check the set value of the command speed and then execute an error reset. If this error occurs, the PCU decelerates the applicable axis to a stop.
						Relative Movement Acceleration Time Error	The acceleration time of relative movement is outside the specified range.	<ul style="list-style-type: none"> Check the set value of the acceleration time and then execute an error reset. If this error occurs, the PCU decelerates the applicable axis to a stop.
						Relative Movement Deceleration Time Error	The deceleration time of relative movement is outside the specified range.	<ul style="list-style-type: none"> Check the set value of the deceleration time and then execute an error reset. If this error occurs, the PCU decelerates the applicable axis to a stop.
						Relative Movement Interrupt Feeding Position Error	The command position of relative movement interrupt feeding is outside the specified range. The command position resulted in 0 movement, and thus the feeding direction was not determined upon interrupt input.	<ul style="list-style-type: none"> Check the set value of the command position and then execute an error reset. If this error occurs, the PCU decelerates the applicable axis to a stop.
						Relative Movement Interrupt Feeding Input Function Setting Error	Interrupt feeding cannot be executed because a latch input is selected for the interrupt input function.	Check the setting of the interrupt input function, and then execute an error reset.
					Relative Movement Interrupt Feeding with No Interrupt Signal	An interrupt input signal was not detected during interrupt feeding.	Check the connection and setting of the interrupt input, and then execute an error reset.	

Indicator			ECAT		7SEG	Error name	Cause	Remedy
RUN	ERC	ERH	RUN	ERR				
ON	ON	—	—	—	AE + Axis number (1 to 16)	Relative Movement Interrupt Feeding Feedback Present Position Overflow	An overflow or underflow occurred in the feedback present position for an interrupt input.	<ul style="list-style-type: none"> Execute an error reset, and then clear the overflow/underflow state by executing an feedback present position preset (IOWR(223) instruction). If this error occurs, the PCU decelerates the applicable axis to a stop.
						Speed Control Speed Error	The command speed of speed control is outside the specified range. Or, one of the following operations was executed during speed control interrupt feeding: <ul style="list-style-type: none"> The command speed was 0 at the time of interrupt input. The command speed was changed to 0 during feeding. The sign of the command speed was changed (reversed) during speed control while waiting for interrupt input. 	<ul style="list-style-type: none"> Check the set value of the command speed and then execute an error reset. If this error occurs, the PCU decelerates the applicable axis to a stop.
						Speed Control Acceleration Time Error	The acceleration time of speed control is outside the specified range.	<ul style="list-style-type: none"> Check the set value of the acceleration time and then execute an error reset. If this error occurs, the PCU decelerates the applicable axis to a stop.
						Speed Control Deceleration Time Error	The deceleration time of speed control is outside the specified range.	<ul style="list-style-type: none"> Check the set value of the deceleration time and then execute an error reset. If this error occurs, the PCU decelerates the applicable axis to a stop.
						Speed Control Interrupt Feeding Position Error	The command position of speed control interrupt feeding is outside the specified range.	<ul style="list-style-type: none"> Check the set value of the command position and then execute an error reset. If this error occurs, the PCU decelerates the applicable axis to a stop.
						Speed Control Interrupt Feeding Input Function Setting Error	Interrupt feeding cannot be executed because a latch input is selected for the interrupt input function.	Check the setting of the interrupt input function, and then execute an error reset.
						Speed Control Interrupt Feeding Feedback Present Position Overflow	An overflow or underflow occurred in the feedback present position for an interrupt input.	<ul style="list-style-type: none"> Execute an error reset, and then clear the overflow/underflow state by executing an feedback present position preset (IOWR(223) instruction). If this error occurs, the PCU decelerates the applicable axis to a stop.
						Present Position Preset Error	The command position of present position preset is outside the specified range.	Check the set value of the command position and then execute an error reset.

13-3 Error Indicators

Indicator			ECAT		7SEG	Error name	Cause	Remedy
RUN	ERC	ERH	RUN	ERR				
ON	ON	—	—	—	AE + Axis number (1 to 16)	High-speed PTP Position Error	The command position of high-speed PTP start is outside the specified range.	<ul style="list-style-type: none"> Check the set value of the command position and then execute an error reset. If this error occurs, the PCU decelerates the applicable axis to a stop.
						High-speed PTP Speed Error	The command speed of high-speed PTP start is outside the specified range.	<ul style="list-style-type: none"> Check the set value of the command speed and then execute an error reset. If this error occurs, the PCU decelerates the applicable axis to a stop.
						High-speed PTP Acceleration Time Error	The acceleration time of high-speed PTP start is outside the specified range.	<ul style="list-style-type: none"> Check the set value of the acceleration time and then execute an error reset. If this error occurs, the PCU decelerates the applicable axis to a stop.
						High-speed PTP Deceleration Time Error	The deceleration time of high-speed PTP start is outside the specified range.	<ul style="list-style-type: none"> Check the set value of the deceleration time and then execute an error reset. If this error occurs, the PCU decelerates the applicable axis to a stop.
						High-speed PTP Direction Specification Error	The rotational axis direction setting of high-speed PTP start is outside the specified range.	<ul style="list-style-type: none"> Check the setting of the rotational axis direction, and then execute an error reset. If this error occurs, the PCU decelerates the applicable axis to a stop.
						High-speed PTP Rotation Axis Upper Limit Exceeded	The command position of high-speed PTP start for a rotation axis exceeds the rotation axis upper limit.	<ul style="list-style-type: none"> Check the set value of the command position and then execute an error reset. If this error occurs, the PCU decelerates the applicable axis to a stop.
						Synchronous Feeding Command Position Overflow	The synchronous feeding command position data given by the Synchronous Data Link exceeded the upper or lower limit of the usable range.	Check the synchronous feeding command position and then execute an error reset. If this error occurs, the PCU causes the applicable axis to a stop immediately.
						Synchronous Feeding Data Offset Setting Invalid	The synchronous feeding data offset settings are invalid.	Check the synchronous feeding data offset settings and then execute an error reset.
						Synchronous Feeding Selection Invalid	Synchronous feeding was started but the synchronous feeding settings were disabled.	Check the synchronous feeding settings and then execute an error reset.
						Synchronous Feeding Velocity Error	The specified synchronous feeding speed command value is outside the specified range.	Check the range of the feeding velocity values and then execute an error reset.
					Synchronous Feeding Torque Option Command Data Offset Invalid	Synchronous feeding was started but the Synchronous Feeding Torque Option Command Data Offset Setting axis parameter was invalid.	Check the offset setting range and then execute an error reset.	

Indicator			ECAT		7SEG	Error name	Cause	Remedy
RUN	ERC	ERH	RUN	ERR				
ON	ON	-	-	-	AE + Axis number (1 to 16)	Control Mode Switching Failed	The speed control or torque control stop process failed.	Check the setting range of the Maximum Speed and Maximum Torque axis parameters and execute an error reset.
						Synchronous Feeding Torque Error	The command torque value for the synchronous feeding torque is outside the specified range.	Check the range of the command torque values and then execute an error reset.
						Velocity Limitation Option Offset Setting Invalid	Synchronous feeding was started but the specified velocity limitation option offset value was invalid.	Check the offset setting range and then execute an error reset.
ON	ON	-	-	-	tx x: Task number (1 to 4)	Multi-start	The Memory Operation Start Bit and a Memory Operation Individual Start Bit were turned ON at the same time for the same task. A memory operation was started for a task whose configuration axes were busy.	<ul style="list-style-type: none"> Check the execution conditions and then execute an error reset. If this error occurs, the PCU decelerates all configuration axes of the applicable task to a stop.
						Sequence Number Error	The sequence number that you specified in the memory operation command is outside the specified range. Sequence data was not yet set for the specified sequence number.	<ul style="list-style-type: none"> Set a sequence number inside the range or check the setting of the memory operation data for the applicable sequence number, and then execute an error reset. If this error occurs, the PCU decelerates all configuration axes of the applicable task to a stop.
						Configuration Axis Error	A configuration axis in the current memory operation task caused an axis error.	<ul style="list-style-type: none"> Remove the cause of the error in the applicable axis, and then execute an error reset. If this error occurs, the PCU decelerates all configuration axes of the applicable task to a stop.
						Interpolation Movement Amount Overflow	The amount of movement for interpolation operation exceeded the usable range during linear interpolation or circular interpolation command.	<ul style="list-style-type: none"> Check the set value of the command position and then execute an error reset. If this error occurs, the PCU decelerates all configuration axes of the applicable task to a stop.
						Deviation between Axes Exceeded	The deviation between the specified interpolation axes exceeded the set value during linear interpolation.	<ul style="list-style-type: none"> Remove the cause of the deviation between the interpolation axes, and then execute an error reset. If this error occurs, the PCU decelerates all configuration axes of the applicable task to a stop.
						Memory Operation Error	The setting of memory operation data is not correct.	<ul style="list-style-type: none"> Check the setting of the memory operation data for the applicable sequence number, and then execute an error reset. If this error occurs, the PCU decelerates all configuration axes of the applicable task to a stop.

13-3 Error Indicators

Indicator			ECAT		7SEG	Error name	Cause	Remedy
RUN	ERC	ERH	RUN	ERR				
ON	ON	—	—	—	tx x: Task number (1 to 4)	Memory Operation Condition Data Error	The setting of memory operation condition data is not correct.	<ul style="list-style-type: none"> Check the setting of the memory operation condition data for the applicable condition number, and then execute an error reset. If this error occurs, the PCU decelerates all configuration axes of the applicable task to a stop.
ON	—	ON	B	—	HF	CPU Unit Watchdog Timer Error	The CPU Unit is not operating properly.	<ul style="list-style-type: none"> Cycle the power supply or restart the PCU. If this error occurs again, replace the Unit. If this error occurs, the PCU will turn OFF all outputs.
ON	—	ON	B	—	H9	Bus Error	An error occurred in PLC bus operation.	
ON	—	ON	—	—	HE	CPU Unit Monitor Error	Processes are not executed properly due to an overload of the CPU Unit.	Check the operating conditions of the CPU Unit.
ON	—	ON	—	—	HH	Fatal CPU Unit Error	A fatal error occurred in the CPU Unit.	<ul style="list-style-type: none"> Remove the cause of the fatal error. If this error occurs, the PCU will turn OFF all outputs.
ON	—	ON	—	—	Y1	Synchronous Control Cycle Setting Error	The synchronous control cycle exceeds the range allowed for the PCU.	Change the Synchronous Cycle Time setting to a value inside the settable range, and then cycle the power supply.
ON	—	ON	—	—	Y2	Synchronous Time Monitoring Timeout	The synchronous control cycle timing could not be obtained successfully.	Check that the PCU is mounted properly, and then cycle the power supply or restart the PCU. If this error occurs again, replace the PCU. If this error occurs, the PCU causes all axes to a stop immediately.
ON	—	ON	—	—	Y3	Synchronous Data Link Reception Error	The Synchronous Data Link could not exchange data successfully.	Check that the PCU is mounted and configured properly for synchronous control with other units, and then execute an error reset. If this error occurs again, replace the PCU. If this error occurs, the PCU decelerates the applicable axis to a stop.
ON	ON	OFF	—	—	E9	CPU Bus Unit Memory Error (Absolute Encoder Data)	The absolute encoder parameters could not be saved normally in nonvolatile memory in the PCU. Or, the absolute encoder parameter data that is saved in the PCU is corrupted.	Once clear the memory corrupted by the data save operation and cancel the error status. Then, execute the Origin Search with the absolute encoder system to define the Absolute Encoder Origin Position Offset parameter again.

Warnings

The warnings are listed below.

Indicator			ECAT		7SEG	Error name	Cause	Remedy
RUN	ERC	ERH	RUN	ERR				
ON	—	—	—	—	—	Master Communications Cycle Exceeded Warning	Updating input data from the slaves could not be completed in the PCU during the communications cycle.	It is possible that the communications cycle is too short for the network configuration to complete PCU processing. Increase the length of the communications cycle.
						IORD Busy	The IORD(222) instruction cannot be executed because data transfer that was performed with a data transfer bit is still in progress. The IORD(222) instruction cannot be executed because the operating mode of the PCU is incorrect.	Check the execution conditions for the IORD(222) instruction.
						IORD Transfer Words Count Invalid	The number of IORD(222) instruction transfer words is outside the specified range.	Check the number of IORD(222) instruction transfer words.
						IORD Control Data Invalid	The IORD(222) instruction control data is outside the specified range. One of the following operations was attempted: <ul style="list-style-type: none"> • Reading the feedback present position of an unused axis • Reading unused latch data 	Check the control data for the IORD(222) instruction.
						IOWR Busy	The IOWR(223) instruction cannot be executed because data transfer that was performed using a data transfer bit is still in progress. The IOWR(223) instruction cannot be executed because the operating mode of the PCU is incorrect.	Check the execution conditions for the IOWR(223) instruction.
						IOWR Transfer Words Count Invalid	The number of IOWR(223) instruction transfer words is outside the specified range.	Check the number of IOWR(223) instruction transfer words.
						IOWR Control Data Invalid	The IOWR(223) instruction control data is outside the specified range. Or, the PCU POSITIONING TRIGGER instruction was executed in one of the following conditions. <ul style="list-style-type: none"> • Specified task number was out of range. • The specified task is not waiting for a command start. 	Check the control data for the IOWR(223) instruction.
						Updated Data Transfer Error at IOWR Setup	A data write was executed with an IOWR(223) instruction to a parameter that becomes valid at startup, restart, or setup.	Any data write performed with the IOWR(223) instruction will be invalid. Check the transfer destination unit address of the IOWR(223) instruction.

13-3 Error Indicators

Indicator			ECAT		7SEG	Error name	Cause	Remedy
RUN	ERC	ERH	RUN	ERR				
ON	—	—	—	—	—	EtherCAT Slave Parameter Download via IOWR Timeout	A timeout occurred during IOWR(223) execution.	Check for network errors, remove the cause of the error, and write the data again.
						EtherCAT Slave Parameter Specification Error for IOWR	The specified data was invalid when writing slave parameters.	Check the settings of the parameters and repeat the operation.
						EtherCAT Network Error for IOWR	The instruction was executed when there was an error on the network (i.e., when message communications were not enabled).	Check for network errors, remove the cause of the error, and write the data again.
						EtherCAT Slave Error for IOWR	Writing was not possible because there was an error in the slave.	Check for slave errors, remove the cause of the error, and then repeat the operation.
						Data Transfer Multi-start	Multiple data transfer operations were executed simultaneously.	Check the execution conditions for the Write Data Bit, Read Data Bit, and Save Data Bit, and data transfer via CX-Programmer.
						Data Read Transfer Words Count Invalid	The number of transfer words for a data read that is performed using a data transfer bit is outside the specified range.	Check the number of data transfer words.
						Data Read CPU Unit Area Invalid	The area in the CPU Unit is outside the specified range for a data read that is performed using a data transfer bit.	Check the setting of the area in the CPU Unit.
						Data Read CPU Unit Start Word Invalid	The setting of the starting word in the CPU Unit is outside the specified range for a data read that is performed using a data transfer bit.	Check the setting of the starting word in the CPU Unit.
						Data Read PCU Area Invalid	The area in the PCU Unit is outside the specified range for a data read that is performed using a data transfer bit.	Check the setting of the area in the PCU.
						Data Read PCU Start Word Invalid	The setting of the starting word in the PCU is outside the specified range for a data read that is performed using a data transfer bit.	Check the setting of the starting word in the PCU.
						Data Read Timeout	A data read that is performed using a data transfer bit was not successful.	Check the operating condition of the CPU Unit, and then execute the data read again.
						EtherCAT Slave Parameter Specification Error for Read Data Bit	The specified data was invalid when reading slave parameters.	Check the settings of the parameters and repeat the operation.
						EtherCAT Network Error for Read Data Bit	The instruction was executed when there was an error on the network (i.e., when message communications were not enabled).	Check for network errors, remove the cause of the error, and read the data again.
						EtherCAT Slave Error for Read Data Bit	Reading was not possible because there was an error in the slave.	Check for slave errors, remove the cause of the error, and read the data again.

Indicator			ECAT		7SEG	Error name	Cause	Remedy
RUN	ERC	ERH	RUN	ERR				
ON	—	—	—	—	—	Data Write Transfer Words Count Invalid	The number of transfer words for a data write that was performed using a data transfer bit is outside the specified range.	Check the number of data transfer words.
						Data Write CPU Unit Area Invalid	The setting of the area in the CPU Unit is outside the specified range for a data write that is performed using a data transfer bit.	Check the setting of the area in the CPU Unit.
						Data Write CPU Unit Start Word Invalid	The setting of the start word in the CPU Unit is outside the specified range for a data write that is performed using a data transfer bit.	Check the setting of the starting word in the CPU Unit.
						Data Write PCU Area Invalid	The setting of the area in the PCU is outside the specified range for a data write that is performed using a data transfer bit.	Check the setting of the area in the PCU.
						Data Write PCU Start Word Invalid	The setting of the starting word in the PCU is outside the specified range for a data write that is performed using a data transfer bit.	Check the setting of the starting word in the PCU.
						Updated Data Transfer Error at Data Write Setup	A data write was executed using a data transfer bit in a condition other than during PCU setup to a parameter that becomes valid at startup, restart, or setup.	Any data write not during PCU setup becomes invalid. Check the area, starting word and execution conditions for writing data to the PCU.
						Data Write Timeout	A data write that was performed using a data transfer bit was not successful.	Check the operating condition of the CPU Unit, and then execute the data write again.
						EtherCAT Slave Parameter Specification Error for Write Data Bit	The specified data was invalid when writing slave parameters.	Check the settings of the parameters and repeat the operation.
						EtherCAT Network Error for Write Data Bit	The instruction was executed when there was an error on the network (i.e., when message communications were not enabled).	Check for network errors, remove the cause of the error, and write the data again.
						EtherCAT Slave Error for Write Data Bit	Writing was not possible because there was an error in the slave.	Check for slave errors, remove the cause of the error, and then repeat the operation.
						Data Save Execution Not Enabled	A data save could not be executed because a simple backup operation was in progress.	Check the execution conditions for data save.
						Data Check Warning	The data to write is outside the specified range. The data is not appropriate due to lack of consistency with other parameters.	Set data to write that is inside the specified range.
						Servo Drive Warning Input	A Servo Drive warning was detected in the Servo Drive.	Remove the cause of the warning from the Servo Drive.

13-3 Error Indicators

Indicator			ECAT		7SEG	Error name	Cause	Remedy
RUN	ERC	ERH	RUN	ERR				
ON	—	—	—	—	—	Command Present Position Overflow	The command present position became greater than the upper limit (overflow) or smaller than the lower limit (underflow) of the usable range.	Clear the overflow/underflow state by executing an origin search or present position preset.
						Feedback Present Position Overflow	The feedback present position became greater than the upper limit (overflow) or smaller than the lower limit (underflow) of the usable range.	Clear the overflow/underflow state by executing an feedback present position preset (IOWR(223) instruction).
						Teaching Address Invalid	The teaching address is outside the specified range.	Check the setting of the teaching address.
						Teaching Execution Not Enabled	Teaching could not be executed because a data save was in progress.	Check the execution conditions for data save and teaching operations.
						Teaching Position Overflow	The present position of the axis for which teaching was executed became greater than the upper limit (overflow) or smaller than the lower limit (underflow) of the usable range.	Clear the overflow/underflow state of the applicable axis by executing an origin search or present position preset.

13-4 Error Flag Configuration

The PCU has the error flags listed in the following table.

Each error flag indicates an individual error state or an error state of a group of errors. They can be used to identify the locations of errors.

Error Flags Related to PCU Control

If an error occurs in the PCU control, error notification is provided with the following status flags. The relevant error flag (PCU Error, Axis Error, or Memory Operation Error Flag) will turn ON in the memory area for the corresponding task if the PCU Common Error, Axis Error, or Memory Operation Error Flags turn ON. At the same time, detailed error information is indicated with the Cause of Error Flag and Error Code.

Error notification with the Axis Status Memory Area and Memory Operation Status Memory Area can be used only if an OMNUC G5-series Servo Drive is connected.

Status flag	Description	Notification area
Overall Error Flag	This flag indicates that an error occurred in the PCU. This flag turns ON when a PCU error, axis error, or memory operation error occurs.	PCU Control Input Memory Area
PCU Error Flag	This flag indicates that an error that is common within the entire PCU system has occurred.	
Restore Error Flag	This flag turns ON when a problem occurs in the settings in the Unit and the system environment.	
Hardware Failure Flag	This flag turns ON when a hardware failure occurs.	
Saved Data Error Flag	This flag turns ON when data is corrupted in nonvolatile memory or when data is corrupted when the power is turned OFF while saving data.	
PLC System Error Flag	This flag turns ON when an error is input from outside the system.	
Absolute Encoder Backup Data Error Flag	Do not use this flag for unit version 1.1 or earlier PCUs because it is reserved as an unused area. In unit version 1.3 or later PCUs, it turns ON when the absolute encoder backup data in nonvolatile memory is corrupted or when the data being saved was corrupted by power off.	
Overall Axis Error Flag	This flag indicates that an axis error occurred in one or more axes.	
Axis Error Flag	This flag indicates that an error occurred in the corresponding axis.	Axis Status Memory Area
Sensor Error Flag	This flag indicates that an error that related to an emergency stop input, limit input, or other external input signal is present.	
Servo Error Flag	This flag indicates that notification of a Servo Drive error or other error was sent from the Servo Drive.	
Execution Error Flag	This flag indicates that there is an error that relates to axis operation, such as multi-starting.	
Overall Memory Operation Error Flag	This flag indicates that a memory operation error occurred for one or more tasks.	PCU Control Input Memory Area
Memory Operation Error Flag	This flag indicates that an error occurred in memory operation for the corresponding task.	Memory Operation Status Memory Area
Memory Operation Execution Error Flag	This flag indicates that there is an error that relates to memory operation, such as multi-starting.	

Error Flags Related to EtherCAT Communications

If an error occurs in the EtherCAT communications control, notification of the error is provided with the following status flags.

When an EtherCAT communications error occurs, the PCU stops process data communications with the slave that generated the error or with all registered slaves, according to the setting of the Operation at Error Detection parameter and the type of error.

At the same time, whether the error causes communications to stop with a specific slave only or with all slaves is indicated by whether the Non-fatal Process Data Communications Error Flag or the Fatal Process Data Communications Error Flag turns ON.

Detailed information about the communications error is indicated with the Cause of Error Flag turning ON. At the same time, the corresponding bit in the Error Slave Table will turn ON to provide notification of the slave node where the error has occurred.

Status flag	Description	Notification area
Non-fatal Process Data Communications Error Flag	This flag turns ON when a non-fatal error occurs in process data communications.	PCU Control Input Memory Area
Fatal Process Data Communications Error Flag	This flag turns ON when a fatal error occurs in process data communications.	
Network Configuration Verification Error Flag	This flag turns ON when the slave information registered in the network configuration information does not agree with the slaves actually in the network.	
Network Configuration Error Flag	This flag turns ON when an unsupported network configuration is detected. It turns ON when the maximum number of slaves is exceeded or when an incorrect topology is detected.	
Process Data Communications Error Flag	This flag turns ON when an error occurs in process data communications.	
Process Data Reception Timeout	This flag indicates that the number of times the EtherCAT frame could not be received during the communications cycle exceeded the timeout detection count in the network settings.	
Communications Parameter Setting Error Flag	This flag turns ON when an error is detected when checking the parameters in the network configuration information.	
Frame Send Timing Error Flag	This flag turns ON when a frame cannot be sent normally.	
Link OFF Error Flag	This flag turns ON when an error occurs while establishing a link with a slave.	
Slave Node Address Duplicated Flag	This flag turns ON when the same node address is used by more than one slave in the network.	
Slave Initialization Error Flag	This flag turns ON when an error occurs during slave initialization processing.	
Slave AL Status Error Flag	This flag turns ON when an AL status error occurs in one or more slaves in the network.	
Error Slave Table	These flags turn ON when a communications errors occurs in corresponding nodes.	
Node 1 Communications Error Flag	This flag turns ON when a communications error occurs in node 1.	
Node 2 Communications Error Flag	This flag turns ON when a communications error occurs in node 2.	

Status flag		Description	Notification area
	Node 3 Communications Error Flag	This flag turns ON when a communications error occurs in node 3.	PCU Control Input Memory Area
	:	:	
	Node 16 Communications Error Flag	This flag turns ON when a communications error occurs in node 16.	Remote I/O Communications Status Memory Area
	Node 17 Communications Error Flag	This flag turns ON when a communications error occurs in node 17.	
	Node 18 Communications Error Flag	This flag turns ON when a communications error occurs in node 18.	
	:	:	
Node 80 Communications Error Flag	This flag turns ON when a communications error occurs in node 80.		



Reference

When an EtherCAT communications error occurs, communications status with the slave where the error occurred or with all registered slaves changes according to the setting of the Operation at Error Detection parameter in the Network Settings. If the Operation at Error Detection parameter is set to stop communications, process data communications will stop for all slaves and the Fatal Process Data Communications Error Flag turns ON.

If the Operation at Error Detection parameter is set to continue operation, process data communications will stop for the corresponding slave or all slaves, depending on the type of error that occurs. The EtherCAT communications control status is indicated by whether the Non-fatal Process Data Communications Error Flag or the Fatal Process Data Communications Error Flag turns ON.

13-4 Error Flag Configuration

If an error occurs in the PCU, execution of functions that relate to axis operation is limited. The following table shows how operations are limited when an error occurs.

Operation	Operations that are enabled after an error occurs	Operations that are disabled after an error occurs	Remarks
PCU operation	Error Reset Bit		
	Warning Reset Bit		
	Write Data Bit		
	Read Data Bit		
	Save Data Bit		
	PCU Setup Bit		
Axis operation	Drive Alarm Reset Bits Deviation Counter Reset Bits Torque Limit Output Bits Override Enable Bits Deceleration Stop Bits Servo Unlock Bits Latch Completed Flag Clear Bits	Servo Lock Bits Forward Jogging/inching Bits Reverse Jogging/inching Bits Origin Search Bits Origin Return Bits Absolute Movement Bits Relative Movement Bits Speed Control Bits Present Position Preset Bits	Operation is limited after occurrence of a PCU error or axis error.
Memory operation	M Code Reset Bit Teaching Bit Memory Operation Stop Bit	Memory Operation Start Bit Memory Operation Individual Start Bit	Operation is limited after occurrence of a PCU error or memory operation error.

Commands for functions whose operation is disabled after an error occurs are invalid unless the error state is reset by an error reset, etc.

All operations are disabled for fatal errors, which required that the PCU is reset. For details on errors, refer to *13-5 Reading Error Codes* on page 13-38.

13-5 Reading Error Codes

If an error occurs, the related error flags in the PCU Control Input Memory Area, Axis Status Memory Area, and Memory Operation Status Memory Area turn ON, and a corresponding error code is input to each area. Check the error codes and take appropriate actions.

The allocations of error flags and word in which an error code is input are given in the following tables.

PCU Control Memory Input Area

Name	PCU Control Memory Input Area	Bits	Description
PCU Error Flag	n+13	12	1: Error 0: No error
PCU Error Code	n+14	00 to 15	Error code (0000 when normal)

Axis Status Memory Area

The first word in the Axis Status Memory Area is C.

Name	Operation memory area								Bits	Description
	Axis 1	Axis 2	Axis 3	Axis 4	Axis 5	Axis 6	Axis 7	Axis 8		
Axis Error	C+5	C+18	C+31	C+44	C+57	C+70	C+83	C+96	12	1: Error 0: No error
Axis Error Code	C+7	C+20	C+33	C+46	C+59	C+72	C+85	C+98	00 to 15	Error code (0000 when normal)

Name	Operation memory area								Bits	Description
	Axis 9	Axis 10	Axis 11	Axis 12	Axis 13	Axis 14	Axis 15	Axis 16		
Axis Error	C+109	C+122	C+135	C+148	C+161	C+174	C+187	C+200	12	1: Error 0: No error
Axis Error Code	C+111	C+124	C+137	C+150	C+163	C+176	C+189	C+202	00 to 15	Error code (0000 when normal)



Precautions for Correct Use

Axis status error status can be used only when connected to an OMNUC G5-series Servo Drive.

Memory Operation Status Memory Area

The first word in Memory Operation Status Memory Area is E.

Name	Memory Operation Status Memory Area				Bits	Description
	Task 1	Task 2	Task 3	Task 4		
Memory Operation Error Flag	E+2	E+8	E+14	E+20	12	1: Error 0: No error
Memory Operation Error Code	E+3	E+9	E+15	E+21	00 to 15	Error code (0000 when normal)

13-6 Error Code List

When an error occurs, the PCU sets the corresponding error flag in the PCU Control Input Memory Area, Axis Status Memory Area or Memory Operation Status Memory Area and also inputs an error code.

You can identify the axis where the error occurred and the type of error from the area in which the error flag was set and the error code that was input.

For the error codes (error log codes) for which the Support Software says to check the error log, check the error log codes on the Support Software. Use the following method.

- ◆ Select Contents from the Help Menu, and then select Error Log Codes from the Troubleshooting item.

Category	Item name	Error code	Cause	Clear method
Common	Restore Error	0001	The easy backup function of the CPU Unit could not restore the backup data properly.	The PCU is using the data that was saved before the restore. Execute restore again, or transfer and save the data again. Only transferring and saving data can be performed until this error is cleared.
	Setting Table Logic Error	0003	The network configuration information is corrupted.	Download the setting file again.
	Link OFF Error	0004	This flag turns ON when an error occurs while establishing a link with a slave.	The cable connection may be bad. Reconnect or replace the cable. Once the cables are connected correctly, reset the error.
	CPU Bus Unit Memory Error (User Data)	0010	User data could not be saved properly to the nonvolatile memory in the PCU. The saved user data is corrupted.	Transfer and save the data again. Only transferring and saving data can be performed until this error is cleared. If this error occurs again, replace the Unit. If this error occurs when you turn ON the power supply, all parameters and data in the PCU are reset to their default setting. If this error occurs, the PCU decelerates all axes to a stop.
	CPU Bus Unit Memory Error (Error Log Data)	0011	An error occurred in the nonvolatile memory that holds the error log of the PCU.	Clear the error log of the PCU, and then cycle the power supply or restart the PCU.
	Hardware Error	0012	An error was detected in the hardware test of the PCU.	Cycle the power supply or restart the PCU. If this error occurs again, replace the Unit.
	Memory Access Error	0013	A memory error occurred in the PCU.	Cycle the power supply or restart the PCU. If this error occurs again, replace the Unit.
	CPU Bus Unit Memory Error (Communications Parameters)	0014	The communications parameters could not be saved normally in nonvolatile memory in the PCU. Or, the communications parameters that were saved are corrupted.	<ul style="list-style-type: none"> ◆ Transfer and save the data again. Only transferring and saving data can be performed until this error is cleared. If this error occurs again, replace the Unit. ◆ If this error occurs when the power supply is turned ON, the communications parameters are not set in the PCU.

13-6 Error Code List

Category	Item name	Error code	Cause	Clear method
Common	Absolute Encoder Backup Data Error Flag	0015	The absolute encoder parameters could not be saved normally in nonvolatile memory in the PCU. Or the absolute encoder parameter data saved is corrupted.	Once clear the memory corrupted by the data save operation and cancel the error status. Then, execute the Origin Search with the absolute encoder system to define the Absolute Encoder Origin Position Offset parameter again.
	Slave Initialization Error	00A0	Slave initialization failed.	<ul style="list-style-type: none"> ♦ Correct the settings data and then download it again. ♦ Cycle the power supply to the slave. ♦ Replace the slave.
	Duplicated Slave Node Address Error	00A1	The same node address is set for more than one slave.	Correct the duplicated node addresses and cycle the power supply.
	Network Configuration Error	00A2	The maximum number of nodes has been exceeded. The EtherCAT communications IN and OUT connections are incorrect.	<ul style="list-style-type: none"> ♦ Review the network configuration and reduce the number of nodes. ♦ Check the EtherCAT wiring and make sure that the connections are correct.
	Network Configuration Verification Error	00A3	The network configuration that is defined in the network configuration information does not agree with the actual network configuration. Note: If a slave with a node address that is not included in the network configuration information is added, the 7- segment display will display d5 + 00.	<ul style="list-style-type: none"> ♦ Review the network configuration. ♦ Correct the settings data and then download it again. ♦ Start any slaves that are not started. ♦ Cycle the power supply to the slave. ♦ Replace a slave.
	Slave AL Status Error	00A4	An error has occurred in one or more slaves on the network.	Remove the cause of the error from the slave.
	Frame Send Timing Error	00A5	The EtherCAT frame cannot be sent within the communications cycle.	Review the communications cycle.
	Process Data Communications Error	00A6	Process data could not be communicated properly.	<ul style="list-style-type: none"> ♦ Review the communications cycle. ♦ Check the cable connections and check for breaks in the cable.
	Process Data Reception Timeout	00AA	The number of times the EtherCAT frame could not be received during the communications cycle exceeded the timeout detection count.	<ul style="list-style-type: none"> ♦ Check the cable connections and check for breaks in the cable. ♦ Check if there is any effect from external noise sources or from a ground fault. ♦ Review the timeout detection count.
	Synchronous Control Cycle Setting Error	00F0	The synchronous control cycle exceeds the range allowed for the PCU.	Change the Synchronous Cycle Time setting to a value inside the settable range, and then cycle the power supply.
	Synchronous Data Link Reception Error	00F1	The Synchronous Data Link could not exchange data successfully.	Check that the PCU is mounted and configured properly for synchronous control with other units, and then execute an error reset. If this error occurs again, replace the Unit. If this error occurs, the PCU causes the applicable axis to a stop immediately.
	Synchronous Time Monitoring Timeout	00F6	The synchronous control cycle timing could not be obtained successfully.	Check that the PCU is mounted properly, and then cycle the power supply or restart the PCU. If this error occurs again, replace the Unit. If this error occurs, the PCU immediately stops all axes.

Category	Item name	Error code	Cause	Clear method
Task errors	Memory Operation Error	2XXX	The setting of memory operation data is not correct. The last three digits of the error code indicate the sequence number under which the error occurred.	Check the setting of the memory operation data for the applicable sequence number, and then execute an error reset. If this error occurs, the PCU decelerates all configuration axes of the applicable task to a stop.
	Memory Operation Condition Data Error	30XX	The setting of memory operation condition data is not correct. The last two digits of the error code indicate the condition number under which the error occurred.	Check the setting of the memory operation condition data for the applicable condition number, and then execute an error reset. If this error occurs, the PCU decelerates all configuration axes of the applicable task to a stop.
Axis errors	Axis Communications Error	00A9	A communications error occurred in the slave.	Remove the cause of the error from the slave and reset the error.
	Main Circuit OFF Error	5007	The main circuits of the Servo Drive turned OFF while the servo was locked.	Check the main circuit power supply and reset the error.
	Forward Limit Error	5008	A forward limit signal was input.	Execute an error reset and then perform a recovery operation in the reverse direction. If a normal state cannot be recovered, check the connection of the forward limit signal and setting of the forward limit input logic. If this error occurs, the PCU stops the applicable axis according to the setting of the applicable axis parameter.
	Reverse Limit Error	5009	A reverse limit signal was input.	Execute an error reset and then perform a recovery operation in the forward direction. If a normal state cannot be recovered, check the connection of the reverse limit signal and setting of the reverse limit input logic. If this error occurs, the PCU stops the applicable axis according to the setting of the applicable axis parameter.
	Emergency Stop Input	500D	An emergency stop signal was input.	Cancel the emergency stop input and then execute an error reset. If the error cannot be reset, check the connection of the emergency stop signal and setting of the emergency stop input logic. If this error occurs, the PCU unlocks the servo of the applicable axis.
	Servo Drive Alarm Input	500F	A Servo Drive alarm was detected in the Servo Drive.	Remove the cause of the Servo Drive error and then execute an error reset. If this error occurs, the PCU unlocks the servo of the applicable axis.
	Multi-start	6000	Multiple functions that cannot be executed simultaneously were executed for the same axis.	Check the execution conditions and then execute an error reset. If this error occurs, the PCU decelerates the applicable axis to a stop.
	Servo Unlocked	6001	An axis operation command was executed while the servo was unlocked.	Execute an error reset, and execute the axis operation command after the servo is locked.

13-6 Error Code List

Category	Item name	Error code	Cause	Clear method
Axis errors	Forward Limit Input	6002	A forward start command was executed when a forward limit signal was being input.	Execute an error reset and then perform a recovery operation in the reverse direction. If this error occurs again, check the connection of the forward limit signal, setting of the forward limit input logic, and execution conditions for start command.
	Reverse Limit Input	6003	A reverse start command was executed when a reverse limit signal was being input.	Execute an error reset and then perform a recovery operation in the forward direction. If this error occurs again, check the connection of the reverse limit signal, setting of the reverse limit input logic, and execution conditions for start command.
	Command Position Forward Software Limit Exceeded	6004	The command position for positioning exceeds the software limit in the forward direction.	Check the command position and software limit setting, and then execute an error reset. If this error occurs, the PCU decelerates the applicable axis to a stop.
	Command Position Reverse Software Limit Exceeded	6005	The command position for positioning exceeds the software limit in the reverse direction.	
	Present Position Unknown	6006	An origin return was executed when the origin was undefined.	Execute an error reset, and execute the command after the origin is defined by executing an origin search or present position preset.
	Deviation Counter Reset Error	6007	An axis operation command was executed while a deviation counter reset signal was output. The deviation counter was reset during an origin search.	Check the execution conditions for deviation counter reset, and then execute an error reset. If this error occurs, the PCU decelerates the applicable axis to a stop.
	Override Error	6008	The override is out of range.	Check the override set value and then execute an error reset. If this error occurs, the PCU decelerates the applicable axis to a stop.
	Command Present Position Overflow	6009	The command present position became greater than the upper limit (overflow) or smaller than the lower limit (underflow) of the usable range.	Execute an error reset and then clear the overflow/underflow state by executing an origin search or present position preset. If this error occurs, the PCU decelerates the applicable axis to a stop.
	Insufficient PDO Allocation	600A	Synchronous feeding was started but the required process data was not mapped.	Check the process data mapping conditions for the start command. Use the Select By Support Function button in the Network Settings to add the required mappings, and then execute an error reset.
	Positioning Timeout	6020	The positioning completed input was not detected within the positioning monitor time.	Check the positioning completed input and then execute an error reset. If this error occurs again, check the connection of the positioning completed signal, input logic, and setting of the positioning monitor time.
Forward Software Limit Error	6021	The software limit in the forward direction was exceeded.	Check the axis operation command and setting of the forward software limit, and then execute an error reset. If this error occurs, the PCU decelerates the applicable axis to a stop.	

Category	Item name	Error code	Cause	Clear method
Axis errors	Reverse Software Limit Error	6022	The software limit in the reverse direction was exceeded.	Check the axis operation command and setting of the reverse software limit, and then execute an error reset. If this error occurs, the PCU decelerates the applicable axis to a stop.
	Position Deviation Exceeded	6023	The deviation between the command present position and present feedback position exceeded the set value.	Remove the cause of the deviation between the command present position and feedback present position, and then execute an error reset. If this error occurs, the PCU decelerates the applicable axis to a stop.
	Speed Deviation Overflow	6024	The deviation between the present command speed and present feedback speed exceeded the set value.	Remove the cause of the deviation between the present command speed and present feedback speed, and then execute an error reset. If this error occurs, the PCU decelerates the applicable axis to a stop.
	Synchronous Feeding Command Position Overflow	6026	The synchronous feeding command position data given by the Synchronous Data Link exceeded the upper or lower limit of the usable range.	Check the synchronous feeding command position and then execute an error reset. If this error occurs, the PCU decelerates the applicable axis to a stop.
	Command Present Position Overflow	6027	The command present position became greater than the upper limit (overflow) or smaller than the lower limit (underflow) of the usable range when the position and speed deviation monitor function was enabled.	Execute an error reset and then clear the overflow/underflow state by executing an origin search or present position preset. If this error occurs, the PCU decelerates the applicable axis to a stop.
	Feedback Present Position Overflow	6028	The feedback present position became greater than the upper limit (overflow) or smaller than the lower limit (underflow) of the usable range when the position and speed deviation monitor function was enabled.	Execute an error reset, and then clear the overflow/underflow state by executing an feedback present position preset (IOWR(223) instruction). If this error occurs, the PCU decelerates the applicable axis to a stop.
	Excessive Position Deviation	6029	The deviation between the command present position and the feedback present position exceeded 30 bits, so processing could not be continued.	<ul style="list-style-type: none"> Remove the cause of the deviation between the command present position and the feedback present position and then reset the error. If this error occurs, the PCU stops the applicable axis according to the setting of the applicable axis parameter.
	Control Mode Switching Failed	6030	The speed control or torque control failed.	Check the setting range of the Maximum Speed and Maximum Torque axis parameters and execute an error reset.
	Absolute Encoder Present Position Restore Overflow	6112	When you use an absolute encoder, the present position became greater than the upper limit (overflow) or smaller than the lower limit (underflow) of the usable range due to the absolute data that was read upon servo lock.	Reset the error, set up the absolute encoder again, and define the origin for the PCU.
Inching Command Position Overflow	6200	The command present position became greater than the upper limit (overflow) or smaller than the lower limit (underflow) of the usable range during inching.	Remove the cause of the command present position overflow/underflow, check the inching width, and then execute an error reset. If this error occurs, the PCU decelerates the applicable axis to a stop.	

13-6 Error Code List

Category	Item name	Error code	Cause	Clear method
Axis errors	Origin Search Reverse Limit Error	6400	The origin search operation was stopped due to detection of a limit input in the direction opposite the origin input detection direction.	Check the input signal for origin search and origin search setting, and then execute an error reset. If this error occurs, the PCU stops the applicable axis or decelerates to a stop according to the setting of the applicable axis parameter.
	Origin Search Direction Limit Error	6401	The origin search operation was stopped due to detection of a limit input in the origin input detection direction.	
	Bidirectional Limit Error	6402	The origin search cannot be continued because the limit inputs in both directions were detected.	
	Origin Proximity/Origin Search Reverse Limit Error	6403	The origin search operation was stopped because the origin proximity input and detection position of the limit input in the direction opposite the origin input detection direction were not appropriate.	Check the origin proximity input and detection position of the limit input in the direction opposite the origin input detection direction, and then execute an error reset. If this error occurs, the PCU stops the applicable axis or decelerates to a stop according to the setting of the applicable axis parameter.
	Origin Proximity/Origin Search Direction Limit Error	6404	The origin search operation was stopped because the origin proximity input and detection position of the limit input in the origin input detection direction were not appropriate.	
	Origin Input/Origin Search Reverse Limit Error	6405	The origin search operation was stopped because the origin input and detection position of the limit input in the direction opposite the origin input detection direction were not appropriate.	Check the origin input and detection position of the limit input in the direction opposite the origin input detection direction, and then execute an error reset. If this error occurs, the PCU stops the applicable axis or decelerates to a stop according to the setting of the applicable axis parameter.
	Origin Input/Origin Search Direction Limit Error	6406	The origin search operation was stopped because the origin input and detection position of the limit input in the origin input detection direction were not appropriate.	
	Origin Input Mask Amount Invalid	6407	The set value of the origin input mask amount is insufficient for the amount of movement that you need to decelerate from the origin search speed to the origin search approach speed, when the Origin Search Operation Mode is set to Proximity Reverse Turn/Origin Input Mask Amount.	Check the origin input mask amount, origin search speed and origin search approach speed, and then execute an error reset. If this error occurs, the PCU decelerates the applicable axis to a stop.
	No Origin Input	6420	The origin input was not detected during an origin search.	Check the connection and setting of the origin input, and then execute an error reset. If this error occurs (upon limit input), the PCU stops the applicable axis according to the setting of the applicable axis parameter.

Category	Item name	Error code	Cause	Clear method
Axis errors	No Origin Proximity Input	6421	The origin proximity input was not detected in an origin search operation that uses the origin proximity input.	Check the connection and setting of the origin proximity input, and then execute an error reset. If this error occurs (upon limit input), the PCU stops the applicable axis according to the setting of the applicable axis parameter.
	Origin Input Mask Position Overflow	6422	The command present position became greater than the upper limit (overflow) or smaller than the lower limit (underflow) of the usable range due to the movement by the origin input mask amount, when the Origin Search Operation Mode was set to Proximity Reverse Turn/ Origin Input Mask Amount.	Check the setting of the origin input mask amount and range of the command present positions used, and then execute an error reset. If this error occurs, the PCU decelerates the applicable axis to a stop.
	Absolute Encoder Origin Position Offset Overflow	6423	When you use an absolute encoder, the absolute encoder origin position offset that was calculated upon completion of the origin search exceeded the setting range.	Set up the absolute encoder again, and then execute an error reset.
	Absolute Encoder Origin Position Offset Calculation Not Possible	6424	When you use an absolute encoder, the feedback present position became greater than the upper limit (overflow) or smaller than the lower limit (underflow) of the usable range during the origin search.	Check the unit setting for feedback input and range of feedback present positions that you use, and then execute an error reset. If this error occurs, the PCU decelerates the applicable axis to a stop.
	Present Position Preset Error	6600	The command position of present position preset is outside the specified range.	Check the set value of the command position and then execute an error reset.
	Absolute Movement Position Error	6700	The command position of absolute movement is outside the specified range.	Check the set value of the command position and then execute an error reset. If this error occurs, the PCU decelerates the applicable axis to a stop.
	Absolute Movement Speed Error	6701	The command speed of absolute movement is outside the specified range.	Check the set value of the command speed and then execute an error reset. If this error occurs, the PCU decelerates the applicable axis to a stop.
	Absolute Movement Acceleration Time Error	6702	The acceleration time of absolute movement is outside the specified range.	Check the set value of the acceleration time and then execute an error reset. If this error occurs, the PCU decelerates the applicable axis to a stop.
	Absolute Movement Deceleration Time Error	6703	The deceleration time of absolute movement is outside the specified range.	Check the set value of the deceleration time and then execute an error reset. If this error occurs, the PCU decelerates the applicable axis to a stop.
	Absolute Movement Direction Specification Error	6704	The rotational axis direction setting of absolute movement is outside the specified range.	Check the setting of the rotational axis direction, and then execute an error reset. If this error occurs, the PCU decelerates the applicable axis to a stop.
Rotation Axis Upper Limit Exceeded	6705	The command position of absolute movement for a rotation axis exceeds the rotation axis upper limit.	Check the set value of the command position and then execute an error reset. If this error occurs, the PCU decelerates the applicable axis to a stop.	

13-6 Error Code List

Category	Item name	Error code	Cause	Clear method
Axis errors	Absolute Movement Interrupt Feeding Position Error	6710	The command position of absolute movement interrupt feeding is outside the specified range. The command position resulted in 0 movement, and thus the feeding direction was not determined upon interrupt input.	Check the set value of the command position and then execute an error reset. If this error occurs, the PCU decelerates the applicable axis to a stop.
	Absolute Movement Interrupt Feeding Input Function Setting Error	6711	Interrupt feeding cannot be executed because a latch input is selected for the interrupt input function.	Check the setting of the interrupt input function, and then execute an error reset.
	Absolute Movement Interrupt Feeding with No Interrupt Signal	6712	An interrupt input signal was not detected during interrupt feeding.	Check the connection and setting of the interrupt input, and then execute an error reset.
	Absolute Movement Interrupt Feeding Feedback Present Position Overflow	6713	An overflow or underflow occurred in the feedback present position for an interrupt input.	Execute an error reset, and then clear the overflow/underflow state by executing an feedback present position preset (IOWR(223) instruction). If this error occurs, the PCU decelerates the applicable axis to a stop.
	Relative Movement Position Error	6800	The command position of relative movement is outside the specified range.	Check the set value of the command position and then execute an error reset. If this error occurs, the PCU decelerates the applicable axis to a stop.
	Relative Movement Speed Error	6801	The command speed of relative movement is outside the specified range.	Check the set value of the command speed and then execute an error reset. If this error occurs, the PCU decelerates the applicable axis to a stop.
	Relative Movement Acceleration Time Error	6802	The acceleration time of relative movement is outside the specified range.	Check the set value of the acceleration time and then execute an error reset. If this error occurs, the PCU decelerates the applicable axis to a stop.
	Relative Movement Deceleration Time Error	6803	The deceleration time of relative movement is outside the specified range.	Check the set value of the deceleration time and then execute an error reset. If this error occurs, the PCU decelerates the applicable axis to a stop.
	Relative Movement Interrupt Feeding Position Error	6810	The command position of relative movement interrupt feeding is outside the specified range. The command position resulted in 0 movement, and thus the feeding direction was not determined upon interrupt input.	Check the set value of the command position and then execute an error reset. If this error occurs, the PCU decelerates the applicable axis to a stop.
	Relative Movement Interrupt Feeding Input Function Setting Error	6811	Interrupt feeding cannot be executed because a latch input is selected for the interrupt input function.	Check the setting of the interrupt input function, and then execute an error reset.
	Relative Movement Interrupt Feeding with No Interrupt Signal	6812	An interrupt input signal was not detected during interrupt feeding.	Check the connection and setting of the interrupt input, and then execute an error reset.
	Relative Movement Interrupt Feeding Feedback Present Position Overflow	6813	An overflow or underflow occurred in the feedback present position for an interrupt input.	Execute an error reset, and then clear the overflow/underflow state by executing an feedback present position preset (IOWR(223) instruction). If this error occurs, the PCU decelerates the applicable axis to a stop.

Category	Item name	Error code	Cause	Clear method
Axis errors	Speed Control Speed Error	6901	The command speed of speed control is outside the specified range. Or, one of the following operations was executed during speed control interrupt feeding: <ul style="list-style-type: none"> • The command speed was 0 at the time of interrupt input. • The command speed was changed to 0 during feeding. • The sign of the command speed was changed (reversed) during speed control while waiting for interrupt input. 	Check the set value of the command speed and then execute an error reset. If this error occurs, the PCU decelerates the applicable axis to a stop.
	Speed Control Acceleration Time Error	6902	The acceleration time of speed control is outside the specified range.	Check the set value of the acceleration time and then execute an error reset. If this error occurs, the PCU decelerates the applicable axis to a stop.
	Speed Control Deceleration Time Error	6903	The deceleration time of speed control is outside the specified range.	Check the set value of the deceleration time and then execute an error reset. If this error occurs, the PCU decelerates the applicable axis to a stop.
	Speed Control Interrupt Feeding Position Error	6910	The command position of speed control interrupt feeding is outside the specified range.	Check the set value of the command position and then execute an error reset. If this error occurs, the PCU decelerates the applicable axis to a stop.
	Speed Control Interrupt Feeding Input Function Setting Error	6911	Interrupt feeding cannot be executed because a latch input is selected for the interrupt input function.	Check the setting of the interrupt input function, and then execute an error reset.
	Speed Control Interrupt Feeding Feedback Present Position Overflow	6913	An overflow or underflow occurred in the feedback present position for an interrupt input.	Execute an error reset, and then clear the overflow/underflow state by executing an feedback present position preset (IOWR(223) instruction). If this error occurs, the PCU decelerates the applicable axis to a stop.
	High-speed PTP Position Error	6A00	The command position of high-speed PTP start is outside the specified range.	Check the set value of the command position and then execute an error reset. If this error occurs, the PCU decelerates the applicable axis to a stop.
	High-speed PTP Speed Error	6A01	The command speed of high-speed PTP start is outside the specified range.	Check the set value of the command speed and then execute an error reset. If this error occurs, the PCU decelerates the applicable axis to a stop.
	High-speed PTP Acceleration Time Error	6A02	The acceleration time of high-speed PTP start is outside the specified range.	Check the set value of the acceleration time and then execute an error reset. If this error occurs, the PCU decelerates the applicable axis to a stop.
	High-speed PTP Deceleration Time Error	6A03	The deceleration time of high-speed PTP start is outside the specified range.	Check the set value of the deceleration time and then execute an error reset. If this error occurs, the PCU decelerates the applicable axis to a stop.
High-speed PTP Direction Specification Error	6A04	The rotational axis direction setting of high-speed PTP start is outside the specified range.	Check the setting of the rotational axis direction, and then execute an error reset. If this error occurs, the PCU decelerates the applicable axis to a stop.	

13-6 Error Code List

Category	Item name	Error code	Cause	Clear method
Axis errors	High-speed PTP Rotation Axis Upper Limit Exceeded	6A05	The command position of high-speed PTP start for a rotation axis exceeds the rotation axis upper limit.	Check the set value of the command position and then execute an error reset. If this error occurs, the PCU decelerates the applicable axis to a stop.
	Synchronous Feeding Data Offset Setting Invalid	6E01	The synchronous feeding data offset settings are invalid.	Check the synchronous feeding data offset settings and then execute an error reset.
	Synchronous Feeding Selection Invalid	6E02	Synchronous feeding was started but the synchronous feeding settings were disabled.	Check the synchronous feeding settings and then execute an error reset.
	Synchronous Feeding Velocity Error	6E10	The specified synchronous feeding speed command value is outside the specified range.	Check the range of the feeding velocity values and then execute an error reset.
	Synchronous Feeding Torque Option Command Data Offset Invalid	6E11	Synchronous feeding was started but the Synchronous Feeding Torque Option Command Data Offset Setting axis parameter was invalid.	Check the offset setting range and then execute an error reset.
	Synchronous Feeding Torque Error	6E12	The command torque value for the synchronous feeding torque is outside the specified range.	Check the range of the command torque values and then execute an error reset.
	Velocity Limitation Option Offset Setting Invalid	6E13	Synchronous feeding was started but the specified velocity limitation option offset value was invalid.	Check the offset setting range and then execute an error reset.
Task errors	Multi-start	6C00	The Memory Operation Start Bit and a Memory Operation Individual Start Bit were turned ON at the same time for the same task. A memory operation was started for a task whose configuration axes were busy.	Check the execution conditions and then execute an error reset. If this error occurs, the PCU decelerates all configuration axes of the applicable task to a stop.
	Sequence No. Error	6C01	The sequence number that you specified in the memory operation command is outside the specified range. Sequence data was not yet set for the specified sequence number.	Set a sequence number inside the range or check the setting of the memory operation data for the applicable sequence number, and then execute an error reset. If this error occurs, the PCU decelerates all configuration axes of the applicable task to a stop.
	Configuration Axis Error	6C02	A configuration axis in the current memory operation task caused an axis error.	Remove the cause of the error in the applicable axis, and then execute an error reset. If this error occurs, the PCU decelerates all configuration axes of the applicable task to a stop.
	Interpolation Movement Amount Overflow	6C04	The amount of movement for interpolation operation exceeded the usable range during linear interpolation or circular interpolation command.	Check the set value of the command position and then execute an error reset. If this error occurs, the PCU decelerates all configuration axes of the applicable task to a stop.
	Deviation between Axes Exceeded	6C20	The deviation between the specified interpolation axes exceeded the set value during linear interpolation.	Remove the cause of the deviation between the interpolation axes, and then execute an error reset. If this error occurs, the PCU decelerates all configuration axes of the applicable task to a stop.

Warnings

The warnings are listed below.

Category	Item name	Error code	Cause	Clear method
Common	Master Communications Cycle Exceeded Warning	80A0	Updating input data from the slaves could not be completed in the PCU during the communications cycle.	It is possible that the communications cycle is too short for the network configuration to complete PCU processing. Increase the length of the communications cycle.
	Synchronous Data Link Reception Warning	80F2	The Synchronous Data Link could not exchange data successfully.	Check that PLC is installed properly.
	IORD Busy	8110	The IORD(222) instruction cannot be executed because data transfer that was performed with a data transfer bit is still in progress. The IORD(222) instruction cannot be executed because the operating mode of the PCU is incorrect.	Check the execution conditions for the IORD(222) instruction.
	IORD Transfer Words Count Invalid	8111	The number of IORD(222) instruction transfer words is outside the specified range.	Check the number of IORD(222) instruction transfer words.
	IORD Control Data Invalid	8112	The IORD(222) instruction control data is outside the specified range. One of the following operations was attempted: <ul style="list-style-type: none"> ♦ Reading the feedback present position of an unused axis ♦ Reading unused latch data 	Check the control data for the IORD(222) instruction.
	IOWR Busy	8120	The IOWR(223) instruction cannot be executed because data transfer that was performed using a data transfer bit is still in progress. The IOWR(223) instruction cannot be executed because the operating mode of the PCU is incorrect.	Check the execution conditions for the IOWR(223) instruction.
	IOWR Transfer Words Count Invalid	8121	The number of IOWR(223) instruction transfer words is outside the specified range.	Check the number of IOWR(223) instruction transfer words.
	IOWR Control Data Invalid	8122	The IOWR(223) instruction control data is outside the specified range. Or, the PCU POSITIONING TRIGGER instruction was executed in one of the following conditions. <ul style="list-style-type: none"> ♦ Specified task number was out of range. ♦ The specified task is not waiting for a command start. 	Check the control data for the IOWR(223) instruction.
	Updated Data Transfer Error at IOWR Setup	8126	A data write was executed with an IOWR(223) instruction to a parameter that becomes valid at startup, restart, or setup.	Any data write performed with the IOWR(223) instruction will be invalid. Check the transfer destination unit address of the IOWR(223) instruction.

13-6 Error Code List

Category	Item name	Error code	Cause	Clear method
Common	EtherCAT Slave Parameter Download via IOWR Timeout	8127	A timeout occurred during IOWR(223) execution.	Check for network errors, remove the cause of the error, and read the data again.
	EtherCAT Slave Parameter Specification Error for IOWR	8128	The specified data was invalid when writing slave parameters.	Check the settings of the parameters and repeat the operation.
	EtherCAT Network Error for IOWR	8129	The instruction was executed when there was an error on the network (i.e., when message communications were not enabled).	Check for network errors, remove the cause of the error, and write the data again.
	EtherCAT Slave Error for IOWR	812A	Writing was not possible because there was an error in the slave.	Check for slave errors, remove the cause of the error, and read the data again.
	Data Transfer Multi-start	8200	Multiple data transfer operations were executed simultaneously.	Check the execution conditions for the Write Data Bit, Read Data Bit, and Save Data Bits, and data transfer via CX-Programmer.
	Data Read Transfer Words Count Invalid	8211	The number of transfer words for a data read that is performed using a data transfer bit is outside the specified range.	Check the number of data transfer words.
	Data Read CPU Unit Area Invalid	8212	The area in the CPU Unit is outside the specified range for a data read that is performed using a data transfer bit.	Check the setting of the area in the CPU Unit.
	Data Read CPU Unit Start Word Invalid	8213	The setting of the starting word in the CPU Unit is outside the specified range for a data read that is performed using a data transfer bit.	Check the setting of the starting word in the CPU Unit.
	Data Read PCU Area Invalid	8214	The area in the PCU Unit is outside the specified range for a data read that is performed using a data transfer bit.	Check the setting of the area in the PCU.
	Data Read PCU Start Word Invalid	8215	The setting of the starting word in the PCU is outside the specified range for a data read that is performed using a data transfer bit.	Check the setting of the starting word in the PCU.
	Data Read Timeout	8217	A data read that is performed using a data transfer bit was not successful.	Check the operating condition of the CPU Unit, and then execute the data read again.
	EtherCAT Slave Parameter Specification Error for Read Data Bit	8218	The specified data was invalid when reading slave parameters.	Check the settings of the parameters and repeat the operation.
	EtherCAT Network Error for Read Data Bit	8219	The instruction was executed when there was an error on the network (i.e., when message communications were not enabled).	Check for network errors, remove the cause of the error, and read the data again.
	EtherCAT Slave Error for Read Data Bit	821A	Reading was not possible because there was an error in the slave.	Check for slave errors, remove the cause of the error, and read the data again.

Category	Item name	Error code	Cause	Clear method
Common	Data Write Transfer Words Count Invalid	8221	The number of transfer words for a data write that was performed using a data transfer bit is outside the specified range.	Check the number of data transfer words.
	Data Write CPU Unit Area Invalid	8222	The setting of the area in the CPU Unit is outside the specified range for a data write that is performed using a data transfer bit.	Check the setting of the area in the CPU Unit.
	Data Write CPU Unit Start Word Invalid	8223	The setting of the start word in the CPU Unit is outside the specified range for a data write that is performed using a data transfer bit.	Check the setting of the starting word in the CPU Unit.
	Data Write PCU Area Invalid	8224	The setting of the area in the PCU is outside the specified range for a data write that is performed using a data transfer bit.	Check the setting of the area in the PCU.
	Data Write PCU Start Word Invalid	8225	The setting of the starting word in the PCU is outside the specified range for a data write that is performed using a data transfer bit.	Check the setting of the starting word in the PCU.
	Updated Data Transfer Error at Data Write Setup	8226	A data write was executed using a data transfer bit, in a condition other than during PCU setup, to a parameter that becomes valid at startup, restart, or setup.	Any data write not during PCU setup becomes invalid. Check the area, starting word and execution conditions for writing data to the PCU.
	Data Write Timeout	8227	A data write that was performed using a data transfer bit was not successful.	Check the operating condition of the CPU Unit, and then execute the data write again.
	EtherCAT Slave Parameter Specification Error for Write Data Bit	8228	The specified data was invalid when writing slave parameters.	Check the settings of the parameters and repeat the operation.
	EtherCAT Network Error for Write Data Bit	8229	The instruction was executed when there was an error on the network (i.e., when message communications were not enabled).	Check for network errors, remove the cause of the error, and read the data again.
	EtherCAT Slave Error for Write Data Bit	822A	Writing was not possible because there was an error in the slave.	Check for slave errors, remove the cause of the error, and read the data again.
	Data Save Execution Not Enabled	8230	A data save could not be executed because a simple backup operation was in progress.	Check the execution conditions for data save.
	Data Check Warning	90XX ^{*1} : Common parameters 91XX ^{*1} : Axis parameters 92XX ^{*1} : Task parameters	The data to write is outside the specified range. The data is not appropriate due to lack of consistency with other parameters.	Set data to write that is inside the specified range.

13-6 Error Code List

Category	Item name	Error code	Cause	Clear method
Axis errors	Servo Drive Warning Input	D00F	A Servo Drive warning was detected in the Servo Drive.	Remove the cause of the warning from the Servo Drive.
	Command Present Position Overflow	E027	The command present position became greater than the upper limit (overflow) or smaller than the lower limit (underflow) of the usable range.	Clear the overflow/underflow state by executing an origin search or present position preset.
	Feedback Present Position Overflow	E028	The feedback present position became greater than the upper limit (overflow) or smaller than the lower limit (underflow) of the usable range.	Clear the overflow/underflow state by executing an feedback present position preset (IOWR(223) instruction).
Task errors	Teaching Address Invalid	ED00	The teaching address is outside the specified range.	Check the setting of the teaching address.
	Teaching Execution Not Enabled	ED01	Teaching could not be executed because a data save was in progress.	Check the execution conditions for data save and teaching operations.
	Teaching Position Overflow	ED02	The present position of the axis for which teaching was executed became greater than the upper limit (overflow) or smaller than the lower limit (underflow) of the usable range.	Clear the overflow/underflow state of the applicable axis by executing an origin search or present position preset.

*1. XX indicates the number of offsets for each parameter (0 to 255).

13-7 Warnings and Overflows

The PCU provides notification of warnings to alert the user on continuation of operation for the following operations that do not affect axis operation.

- ♦ Errors that are related to data transfer
- ♦ Present position overflows

These warnings are provided according to one of the status depending on the cause of error.

PCU warnings: Warnings that relate to data transfer or other control warnings that are common to the overall PCU

Axis warnings: Command present position overflows, feedback present position overflows, or other warnings that relate to control of each axis

Memory operation warnings: Warnings that relate to teaching

If a warning occurs, a warning code is output to the error code words in the status areas.

If an error occurs while a warning is present, the error code overwrites the warning code.

Overflows/Underflows

The command present positions and feedback present positions that are usable with the PCU are from $-2,147,483,648$ to $2,147,483,647$ command units.

If the present position goes outside this range during axis operation, the present position update is stopped and the origin becomes undefined. At this time, one of the warnings below occurs and the status in memory is updated.

Axis warnings

Item name	Warning code
Command Present Position Overflow	E027
Feedback Present Position Overflow	E028

Status

Item name	Description
Command Present Position Overflow Flag	The command present position in pulses became greater than the upper limit (2,147,483,647).
Command Present Position Underflow	The command present position in pulses became smaller than the lower limit ($-2,147,483,648$).
Feedback Present Position Overflow Flag	The feedback present position in pulses became greater than the upper limit (2,147,483,647).
Feedback Present Position Underflow	The feedback present position in pulses became smaller than the lower limit ($-2,147,483,648$).

If a command present position overflow/underflow occurs, operations except for jogging in the reverse direction and axis operations for which clearing the present position at startup is enabled cannot be executed until you clear the overflow/underflow state.

If you execute any of these operations, command present position overflow error (error code: 6009) will occur.

An error reset or warning reset does not clear the overflow/underflow state.

To clear the overflow/underflow state, define the origin again by executing a present position preset or origin search.

13-8 Resetting Errors

The PCU indicates errors that are common to overall PCU operation, as well as errors that occur in each axis and task in the PCU Operation Input Memory Area, Axis Status Memory Area, and Memory Operation Status Memory Area using error flags and error codes.

These error states are cleared by an error reset that is executed after the cause of the error is removed. Similarly, warning states are cleared by executing a warning reset.



Precautions for Correct Use

Troubleshooting methods are different when connected to an OMNUC G5-series Servo Drive and when connected to another type of slave. For details, refer to *Troubleshooting Errors That Occur When Connected to Remote I/O Slaves* on page 13-14.

First Word in Memory Area

There are two types of operation memory areas: one where the operation memory area is located in the PLC CPU Bus Unit Area and the others where the memory area is set in the common parameters.

You can set the Manual Operation Command Memory Area, Direct Operation Command Memory Area, Axis Status Memory Area, Memory Operation Command Memory Area, and Memory Operation Status Memory Area in any of the following five areas.

Area	Area name	Setting word range
Not set	–	–
CIO Area	Core I/O Area	CIO 0000 to CIO 0159
WR Area	Work Area	W000 to W511
HR Area	Holding Area	H000 to H511
DM Area	Data Memory Area	D00000 to D32767
EM Area	Extended Data Memory Area	E00_00000 to E6C_32767CH ^{*1}

*1. The number of banks that can be used depends on the model of the CPU Unit.

Error Reset Bits

An Error Reset Bit and Warning Reset Bit are assigned in memory as shown in the following table.

Name	Word in PCU Control Input Memory Area	Bit	Description
Error Reset Bit	n	00	Turn ON this bit to reset errors that are common to overall PCU operation.
Warning Reset Bit	n	01	Turn ON this bit to reset warnings that are common to overall PCU operation.

The PCU Control Memory Area is allocated in the CPU Bus Unit Area.

The first word that is allocated to the PCU in the CPU Bus Unit Area can be calculated from the unit number of the PCU using the following formula.

First word allocated to PCU in CPU Bus Unit Area, $n = \text{CIO } 1500 + 25 \times \text{unit number}$

Error Flags

There are four types of error flags: error flags for the PCU, error flags for EtherCAT communications, error flags for axes, and error flags for memory operation.

Errors flags for axes and memory operation are enabled when the PCU is connected to an OMNUC G5- series Servo Drive.

PCU Error Flags

The following error flags are related to the PCU.

Name	Word in PCU Control Input Memory Area	Bit	Description
Restore Error Flag	n+13	00	This flag turns ON when there is an inconsistency between internal PCU settings and the system environment. This flag turns ON when an error is detected when checking the parameters in the network configuration information.
Synchronous Data Link Reception Error Flag	n+13	01	This flag turns ON when two or more attempts to deliver synchronous data from the CPU fail or when a synchronization time monitoring timeout error occurs.
Absolute Encoder Backup Data Error Flag	n+13	05	Do not use this flag for unit version 1.1 or earlier PCUs because it is reserved as an unused area. In unit version 1.3 or later PCUs, it turns ON when the absolute encoder backup data in nonvolatile memory is corrupted or when the data being saved was corrupted by power off.
Hardware Failure Flag	n+13	07	This flag turns ON when a hardware failure occurs.
Saved Data Error Flag	n+13	08	This flag turns ON when data is corrupted in nonvolatile memory or when data is corrupted when the power is turned OFF while saving data.

Name	Word in PCU Control Input Memory Area	Bit	Description
PLC System Error Flag	n+13	09	This flag turns ON when an error is input from outside the system.
PCU Error Flag	n+13	12	This flag turns ON when a common error within in the PCU is detected.
Overall Axis Error Flag	n+13	13	This flag turns ON when an axis error occurs.
Overall Memory Operation Error Flag	n+13	14	This flag turns ON when a memory operation error occurs.
Overall Error Flag	n+13	15	This flag turns ON when an error occurs in the PCU.

EtherCAT Communications Error Flags

The following error flags are related to EtherCAT communications.

Name	Word in PCU Control Input Memory Area	Bit	Description
Network Configuration Verification Error Flag	n+19	00	This flag turns ON when the slave information registered in the network configuration information does not agree with the slaves actually in the network.
Network Configuration Error Flag	n+19	01	This flag turns ON when an unsupported network configuration is detected. It turns ON when the maximum number of slaves is exceeded or when an incorrect topology is detected.
Process Data Communications Error Flag	n+19	02	This flag turns ON when an error occurs in process data communications.
Process Data Reception Timeout Flag	n+19	03	This flag turns ON when the number of times the EtherCAT frame can not be received during the communications cycle exceeds the timeout detection count.
Communications Parameter Setting Error Flag	n+19	04	This flag turns ON when an error is detected when checking the parameters in the network configuration information.
Frame Send Timing Error Flag	n+19	05	This flag turns ON when a frame cannot be sent normally.
Link OFF Error Flag	n+19	09	This flag turns ON when an error occurs while establishing a link with a slave.
Slave Node Address Duplicated Flag	n+19	10	This flag turns ON when the same node address is used by more than one slave in the network.
Slave AL Status Error Flag	n+19	11	This flag turns ON when an AL status error occurs in one or more slaves in the network.
Slave Initialization Error Flag	n+19	12	This flag turns ON when an error occurs during slave initialization processing.
Non-fatal Process Data Communications Error Flag	n+19	14	This flag turns ON when a non-fatal error occurs in process data communications.
Fatal Process Data Communications Error Flag	n+19	15	This flag turns ON when a fatal error occurs in process data communications.

Name	Word in PCU Control Input Memory Area	Bit	Description
Node 1 Communications Error Flag	n+24	00	These flags turn ON when any of the following communications errors occur in the corresponding nodes. <ul style="list-style-type: none"> ◆ Slave initialization error ◆ Duplicated slave address ◆ Slave AL status error ◆ Network configuration verification error ◆ Process data communications error
Node 2 Communications Error Flag	n+24	01	
:	:	:	
Node16 Communications Error Flag	n+24	15	
Node 17 Communications Error Flag	J+16	00	
Node 18 Communications Error Flag	J+16	01	
:	:	:	
Node 80 Communications Error Flag	J+19	15	

Axis Status Error Flags

The following table shows the allocations when the First Word in the Axis Status Memory Area parameter is set to word "C."

Name	Operation Memory Area				Bit	Description
	Axis 1	Axis 2	Axis 3	Axis 4		
Axis Busy Flag	C+2	C+15	C+28	C+41	00	This flag is ON when the axis is busy.
Sensor Error Flag	C+5	C+18	C+31	C+44	08	This flag turns ON when an error is detected for an external sensor, such as for the emergency stop input or a limit input.
Servo Error Flag					09	This flag turns ON when notification of an error is received from outside the system, such as for a Servo Drive alarm occurrence.
Execution Error Flag					10	This flag turns ON when an error such as a multi-start error occurs due to insufficiency of execution conditions or command values of the executed axis operation command.
Axis Warning Flag					11	This flag turns ON when a warning occurs.
Axis Error Flag					12	This flag turns ON when an axis error occurs.



Precautions for Correct Use

Axis status error status can be used only when connected to an OMNUC G5-series Servo Drive.

Memory Operation Status

The following table shows the allocations when the First Word in the Memory Operation Status Memory Area parameter is set to word “E.”

Name	Memory Operation Status Memory Area				Bit	Description
	Task 1	Task 2	Task 3	Task 4		
Memory Operation Busy Flag	E+1	E+7	E+13	E+19	00	It remains ON while a task configuration axis is busy or a task function is being executed.
Memory Operation Execution Error Flag	E+2	E+8	E+14	E+20	10	This flag turns ON when an operation error occurs for the task function.
Memory Operation Warning Flag					11	This flag turns ON when a warning occurs in memory operation.
Memory Operation Error Flag					12	This flag turns ON when an memory operation error occurs.

Timing Chart

The timing chart below shows that the immediate stop input turns ON during an absolute movement of axis 1 of the PCU.

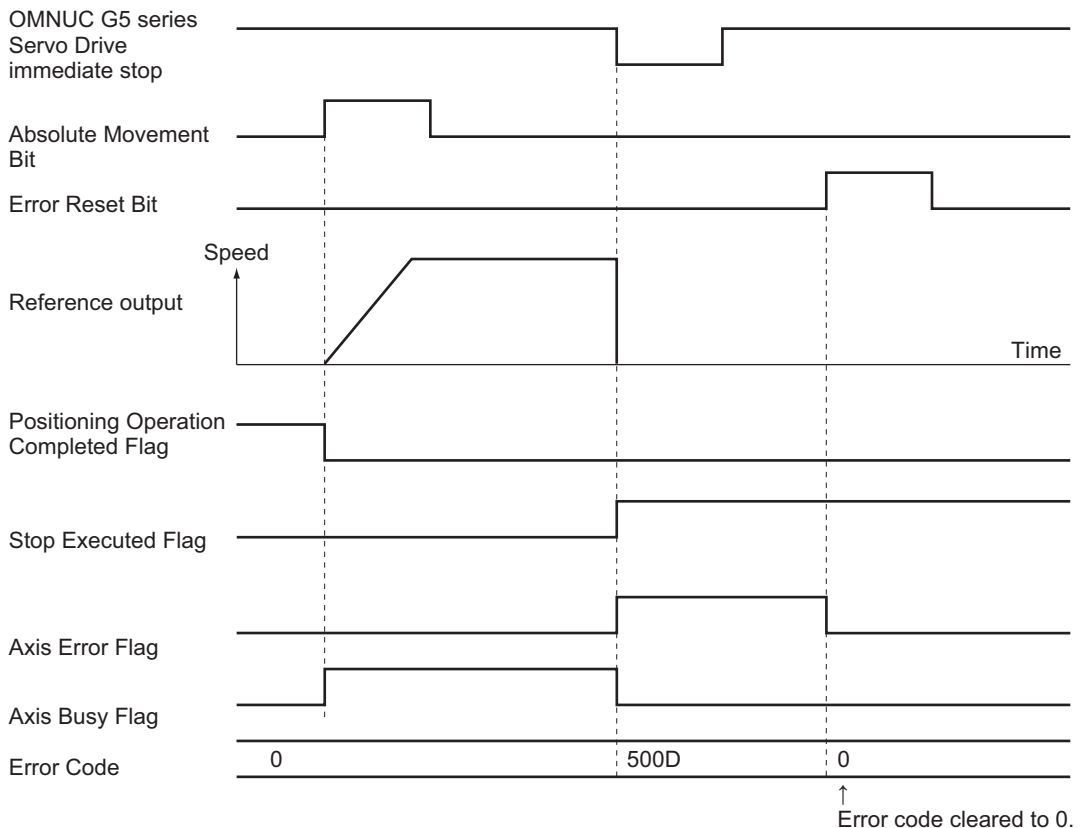

13-9 Error Indications as a CPU Bus Unit

The CPU Unit monitors the PCU, which is a CPU Bus Unit, for the following items:

- ♦ Is the PCU hardware normal?
- ♦ Is the unit number inside the setting range?
- ♦ Is the unit number duplicated?
- ♦ Is refreshing between the CPU Unit and PCU normal?

If an error is detected in the above monitoring, the applicable flag of the following flags turns ON in the Auxiliary Area of the CPU Unit. (For details on each flag, refer to the manuals for CPU Unit.)

- ♦ CPU Bus Unit Duplicated Unit Number Flag
- ♦ CPU Bus Unit Setting Error Flag
- ♦ CPU Bus Unit Setting Error Unit Number Flag
- ♦ CPU Bus Unit Error Flag
- ♦ CPU Bus Unit Error Unit Number Flag

To reset the error, perform the applicable action as described in *13-3 Error Indicators* on page 13-16 and *13-6 Error Code List* on page 13-40.

You can turn ON one of the Restart Bits in the following table to restart the PCU without cycling the power supply to the PCU.

Restart Bits

Bit address	Function
A50100 to A50115	Restart Bits for unit numbers 0 to F

14

Maintenance and Inspection

This section describes periodic maintenance and inspection.

14-1	Items to Inspect.....	14-1
14-2	Handling Precautions	14-3
14-3	PCU Replacement Procedure	14-4

14-1 Items to Inspect

The PCU primarily consists of semiconductors, which means there are few components that have a limited service life. However, semiconductor elements may deteriorate depending on the environment and conditions in which they are used. You need to inspect the PCU regularly in order to use its functions in the best conditions.

The standard inspection period is once every six months to a year. However, it's advisable to shorten the inspection interval depending on the operating environment.

If the inspected items are not within the criteria, make necessary corrections to meet the criteria.

Items to Inspect Periodically

No.	Inspection item	Inspection point	Criteria	Remedy
1	Ambient environment	Is the ambient temperature appropriate? (If you use the PCU in a panel, the ambient temperature inside the panel is the ambient temperature that needs to be inspected.)	0 to 55°C	Use a thermometer to measure the PCU ambient temperature, and adjust the ambient environment so that the temperature is within the operating ambient temperature range.
		Is the ambient humidity level (humidity in a panel) appropriate? (If you use the PCU in a panel, the ambient humidity level inside the panel is the ambient humidity level that needs to be inspected.)	It must be between 10% and 90% with no condensation.	Use a hygrometer to measure the PCU ambient humidity level, and adjust the environment so that the humidity is within the operating ambient humidity range of 10% to 90%. In particular, make sure there is no condensation due to sudden temperature changes.
		Is the PCU subject to direct sunlight?	There must be no direct sunlight.	Shield the PCU from sunlight.
		Is there any accumulation of dirt, dust, saline materials, or iron powder on the PCU?	None	Remove any accumulation and shield the PCU.
		Are there any drops of water, oil, or chemicals on the PCU?	None	Remove any accumulation and shield the PCU.
		Does the environment contain corrosive gas or flammable gas?	None	Check the environment based on smell or with a gas sensor.
		Is there any direct vibration or shock on the PCU?	These must be within the specification ranges for vibrations and impacts.	Place cushions or other materials to suppress vibration and shock.
		Is there a source of noise near the PCU?	None	Move the noise source away from the PCU or shield the PCU.

No.	Inspection item	Inspection point	Criteria	Remedy
2	Installation and wiring conditions	Is the PCU securely mounted?	There must be no looseness.	Lock the sliders firmly.
		Is the connecting cable connector completely inserted and locked?	There must be no looseness.	Completely insert and lock it.
		Are any of the screws for external wiring loose?	There must be no looseness.	Use a Phillips screwdriver to tighten the screws.
		Is the external wiring cable damaged?	There must be no apparent abnormality.	Visually check and replace the cable if necessary.

Tools Required for Inspection

Required Tools

- ♦ Phillips screwdriver
- ♦ Tester or digital voltage meter
- ♦ Industrial alcohol and all cotton cloth

Measuring Equipment (If Necessary)

- ♦ Synchroscope
- ♦ Pen-writing oscilloscope
- ♦ Thermometer and hygrometer

14-2 Handling Precautions

Be sure to turn OFF the power supply before you replace the PCU.

If you find a faulty PCU and replace it, make sure that there are no problems with the new PCU. When you return a faulty PCU for repair, describe the problem in detail, attach the description to the actual PCU, and ask the nearest point of contact printed at the end of this manual for repair.

For connections with poor contact, dampen a clean 100% cotton cloth with industrial alcohol and use it to remove any lint, and then mount the PCU.

14-3 PCU Replacement Procedure

When you need to replace the PCU due to a failure or other reasons, follow the procedure given below.

Replacing the PCU with the Simple Backup Procedure

1. Record the unit number of the PCU that is being replaced.
2. Save the parameters and operation data of the PCU that is being replaced to a Memory Card using the simple backup procedure.
Save the current parameters and operation data.
3. Turn OFF the power supply to the PLC.
4. Record the wiring status to enable rewiring later.
It is convenient to place tags on the cables.
5. Replace the PCU and wire the cables as they originally were.
6. Set the unit number of the PCU.
7. Turn ON pin 7 and turn OFF pin 8 on the DIP switch on the front of the CPU Unit and then turn ON the power supply to the PCU.
8. Use the Memory Card to which the parameters and operation data were saved to restore the parameters and operation data to the PCU.
9. Turn OFF the power supply to the PCU, turn OFF pins 7 and 8 on the DIP switch on the front of the PCU, and then turn ON the power supply to the PCU.



Reference

Verify the data as required.

Replacing the PCU with the CX-Programmer

If you are using a CX-Programmer version lower than version 9.0, upgrade to version 9.0 or higher. If you cannot upgrade, use the above simple backup procedure instead.

- (1) Record the unit number of the PCU that is being replaced.
- (2) Save the parameters and the operating data of the PCU for replacement to your hard disk with the CX-Programmer's PLC backup function (supported for version 9.0 or higher). (Save the parameters and the operating data before removing the PCU that is being replaced.)
- (3) Turn OFF the power supply to the PLC.
- (4) Record the wiring status to enable rewiring later.
It is convenient to place tags on the cables.
- (5) Replace the PCU and wire the cables as they originally were.
- (6) Set the unit number of the PCU.
- (7) Turn ON the power supply to the PLC.
- (8) Transfer the saved parameters and the operating data to the PLC from the CX-Programmer.
- (9) Cycle the power supply to the PLC.

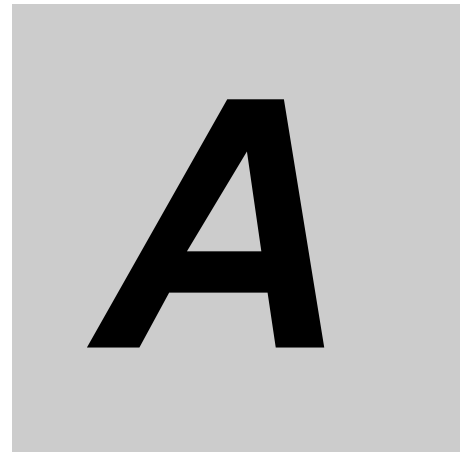

Appendix



The appendix contains performance tables and describes how these PCUs are different from previous models.

Appendix-1 Performance List	A-1
Appendix-2 Comparison to Previous Position Control Units	A-7



Appendix-1 Performance List

Startup Time

The PCU executes initialization when the power supply is turned ON or the PCU is restarted. The time which takes to recognize a start command is shown below.

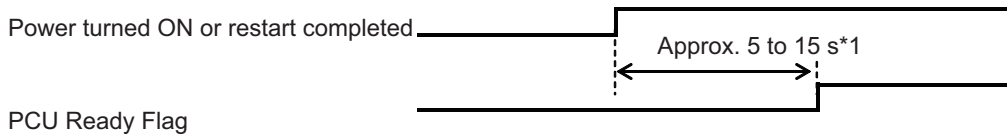

*1. The startup time will depend on the number of slaves that are connected. When using a CPU Unit with a built-in EtherNet/IP port, the above times will increase by approx. 1 s.

The PCU turns OFF the PCU Ready Flag during initialization after you turn ON the power supply or restart the PCU, and turns it ON when initialization is completed.

Command Response Time

The time that is required from when a start command is given for an axis operation to when references are output depends on the contents of the command and the operating status of the PCU.

This section shows various command response times of the PCU as reference values based on the following equipment configuration.

CPU Unit: CJ2M-CPU□□

PCU: Only one PCU (CJ1W-NCF81) is mounted on the CPU Rack

Direct Operation Starting Time

The time from when the PCU acknowledges a start command until an axis operation command is output on EtherCAT communications is shown in the following table.

Number of physical axes used	Control cycle	Communica-tions cycle	Starting an axis with the Absolute Movement Bit, Relative Movement Bit, or Speed Control Bit when all axes are stopped	Starting one axis with a high-speed PTP start instruction (NCDMV) when all axes are stopped	Changing target position/speed during axis operation for multi-starting
1 to 2 axes	0.5 ms	0.25 ms	0.75 to 1.25 ms	0.15 to 0.4 ms ^{*1}	0.75 to 1.25 ms
3 to 4 axes	1.0 ms	0.25 ms	1.25 to 2.25 ms	0.15 to 0.4 ms ^{*1}	1.25 to 2.25 ms
5 to 10 axes	2.0 ms	0.5 ms	2.5 to 4.5 ms	0.15 to 0.8 ms	2.5 to 4.5 ms
11 to 16 axes	2.0 ms	1.0 ms	3.0 to 5.0 ms	0.15 to 1.2 ms	3.0 to 5.0 ms

*1. The range is 0.15 to 0.65 ms when using the Synchronous Data Link function.

Memory Operation Starting Time

The time from when the PCU acknowledges a start command until an axis operation command is output on EtherCAT communications is shown in the following table.

Number of physical axes used	Control cycle	Communi-cations cycle	Starting an au-tomatic pat-tern when all tasks are stopped	Starting an continuous pattern for linear or circular interpolation when all tasks are stopped	Starting PTP position-ing with the PCU POSITIONING TRIG-GER instruction (NCDTR) when wait-ing for a condition during memory operation	Starting PTP linear or circular interpola-tion with the PCU POSITIONING TRIG-GER instruction (NCDTR) when wait-ing for a condition during memory operation
1 to 2 axes	0.5 ms	0.25 ms	0.75 to 1.25 ms	1.75 to 2.25 ms	0.15 to 0.4 ms	0.75 to 1.75 ms
3 to 4 axes	1.0 ms	0.25 ms	1.25 to 2.25 ms	3.25 to 4.25 ms	0.15 to 0.4 ms	1.25 to 3.25 ms
5 to 10 axes	2.0 ms	0.5 ms	2.5 to 4.5 ms	6.5 to 8.5 ms	0.15 to 0.8 ms	2.5 to 6.5 ms
11 to 16 axes	2.0 ms	1.0 ms	3.0 to 5.0 ms	7.0 to 9.0 ms	0.15 to 1.2 ms	3.0 to 5.0 ms

External Interrupt Response Time

The response time to an external input, such as a limit input or an interrupt input, is shown below.

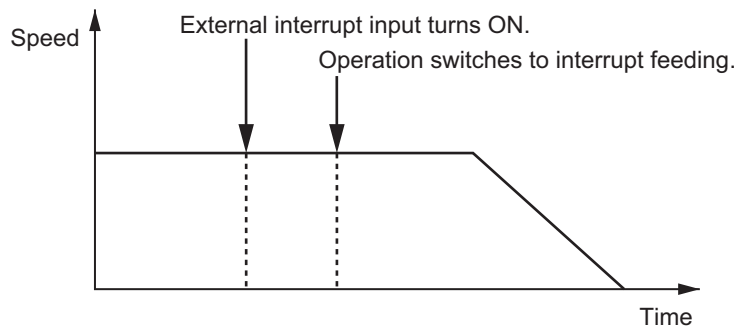

Number of physical axes used	Control cycle	Communi-cations cycle	Position latch ac-curacy for inter-rupt input for interrupt feeding*1	Switching time for interrupt feeding for interrupt in-put*2	Stop command output time for emergency stop input	Stop command output time for limit input
1 to 2 axes	0.5 ms	0.25 ms	0.1 ms max.	1.25 to 1.75 ms	1.25 to 1.75 ms	1.25 to 1.75 ms
3 to 4 axes	1.0 ms	0.25 ms	0.1 ms max.	1.75 to 2.75 ms	1.75 to 2.75 ms	1.75 to 2.75 ms
5 to 10 axes	2.0 ms	0.5 ms	0.1 ms max.	3.25 to 5.25 ms	3.25 to 5.25 ms	3.25 to 5.25 ms
11 to 16 axes	2.0 ms	1.0 ms	0.1 ms max.	4.25 to 6.25 ms	4.25 to 6.25 ms	4.25 to 6.25 ms

*1. This is the accuracy of position latching for an interrupt input for an OMRON G5-series Servo Drive.

*2. This is the time required for the PCU to switch to interrupt feeding after the external interrupt input has turned ON. If the time required for the interrupt feeding amount is shorter than this time, interrupt feeding will go past the target position and then return to the target position.

Input/Output Response Time

The command response time of a PCU is defined as the sum of the time between the execution of a command from the PLC itself (user program) and the actual operation of the slave plus the time taken until a change in the slave's state (such as a change in the present value or status) is reflected to the PLC (user program).

The command response time depends on the PLC's cycle time, the PCU's control cycle, EtherCAT communications cycle, and EtherCAT slave's processing time against the command.

Slave's Output Response Time against a Command Executed from PLC

This response time is measured between when an I/O refresh (OUT refresh) occurs on the cycle in which a command is executed from the PLC and when the slave begins output based on that command.

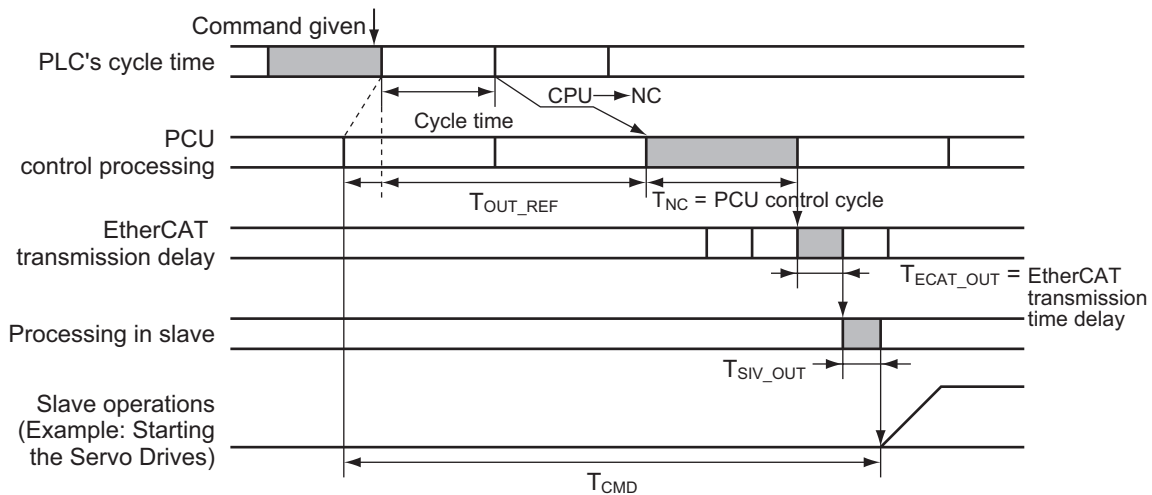

Maximum time between when an end refresh occurs on the cycle in which a command is executed from the user program and when the PCU actually acknowledges the command:

$$T_{OUT_REF} = (\text{Larger time of either PLC's cycle time or PCU control cycle}) + \text{PCU control cycle} \times 1$$

PCU processing time between when the PCU acknowledges the command and when it sends data over the Ethernet communications link:

$$T_{NC} = \text{PCU control cycle} \times 1$$

EtherCAT communications link transmission processing time:

$$T_{ECATCH_OUT} = \text{EtherCAT communications cycle} \times 1$$

Processing time taken for the slave to execute the acknowledged command:

$$T_{SLV_OUT} = \text{Depending on command response time of slaves}$$

The maximum time taken for the slave to actually operate against the command from the PLC (user program),

T_{CMD} is determined by summing the above values.

$$T_{CMD(MAX)} = T_{OUT_REF} + T_{NC} + T_{ECATCH_OUT} + T_{SLV_OUT}$$

Note. T_{CMD} depends on the width of T_{OUT_REF} .

Response Time for the PLC to Reflect the Slave's Input/State Changes

This response time is measured between when the PLC acquires the input/state from the slave and when it reflects the state as part of its I/O refresh (IN refresh).

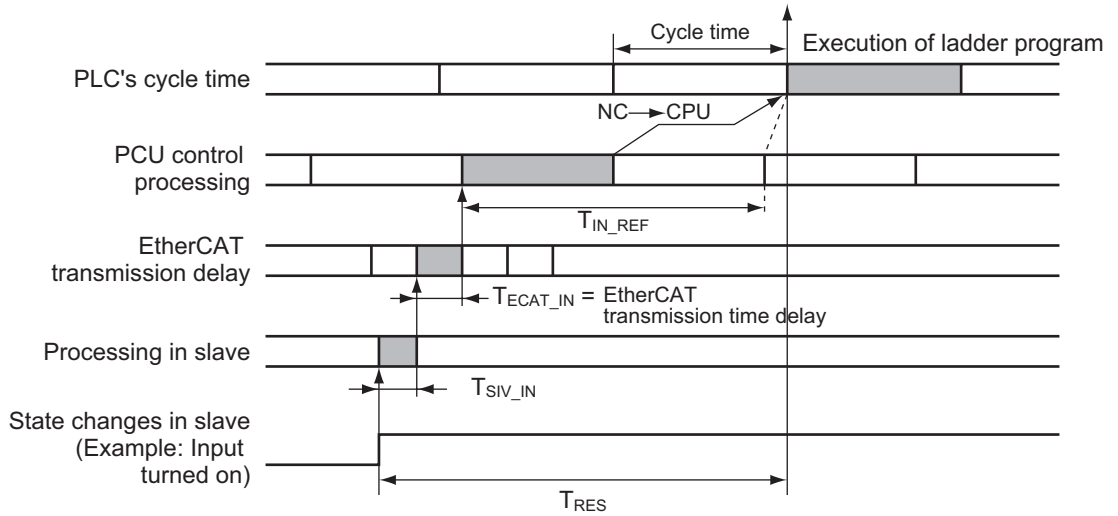

Processing time taken until the state change acquired from the slave is sent over EtherCAT communications link:

T_{SLV_IN} = Depending on command response time of slaves

Processing time for the PCU to acquire the data from the EtherCAT communications link:

$T_{ECAT_IN} = \text{PCU control cycle} \times 1$

Maximum time taken until the state change acquired by the PCU is reflected on the PLC's allocated memory area (via an IN refresh):

$T_{IN_REF} = (\text{Larger time of either PLC's cycle time or PCU control cycle}) + \text{PLC's cycle time} \times 1$

The maximum time taken until the Servo Drive's state change is reflected on the PLC (user program),

T_{RES} is determined by summing the above values.

$T_{RES(MAX)} = T_{SLV_IN} + T_{ECAT_IN} + T_{IN_REF}$

Note. T_{RES} depends on the width of $T_{ECAT_IN} + T_{IN_REF}$.

I/O Response Time for Remote I/O

When you use the Remote I/O Master function of the PCU, the maximum and minimum I/O response times for remote I/O are determined as follows:

Maximum I/O Response Time

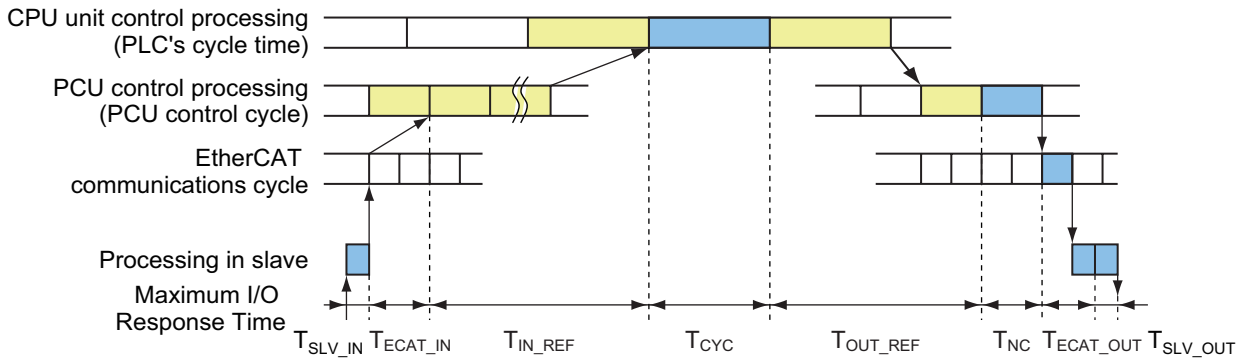

$$\begin{aligned}
 & T_{SLV_IN} + T_{ECAT_IN(MAX)} + T_{IN_REF(MAX)} + T_{CYC} + T_{OUT_REF(MAX)} + T_{NC} + T_{ECAT_OUT} + T_{SLV_OUT} \\
 & = T_{SLV_IN} + T_{CYC} \times 3 + T_{NC} \times 3 + T_{ECAT_CYC} + T_{SLV_OUT} \text{ (When } T_{CYC} \text{ is larger than } T_{NC}\text{)} \\
 & = T_{SLV_IN} + T_{CYC} \times 4 + T_{NC} \times 4 + T_{ECAT_CYC} + T_{SLV_OUT} \text{ (When } T_{CYC} \text{ is approximately equal to } T_{NC}\text{)} \\
 & = T_{SLV_IN} + T_{CYC} \times 2 + T_{NC} \times 3 + T_{ECAT_CYC} + T_{SLV_OUT} \text{ (When } T_{CYC} \text{ is smaller than } T_{NC}\text{)}
 \end{aligned}$$

T_{CYC} : PLC's cycle time

T_{ECAT_CYC} : EtherCAT communications cycle

Minimum I/O Response Time

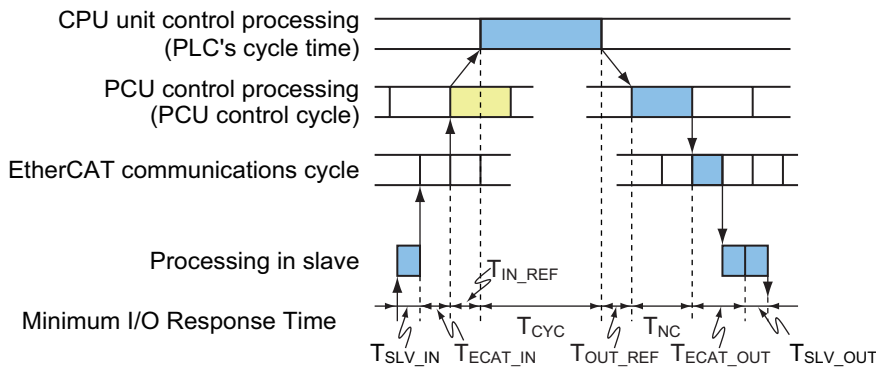

$$T_{SLV_IN} + T_{ECAT_CYC} + T_{CYC} + T_{NC} + T_{ECAT_CYC} + T_{SLV_OUT}$$

Effect on the Cycle Time of the CPU Unit

The cycle time of the PLC increases as follows for each PCU that is connected to a Rack.

Item			Control cycle	Communi-cations cycle	CJ2H-CPU□□	CJ2M-CPU□□
Additional time per PCU	CJ1W-NC281	When 2 axes and 2 task are used	0.5 ms	0.25 ms	0.3 ms	0.3 ms
	CJ1W-NC481	When 4 axes and 4 task are used	1.0 ms	0.25 ms	0.3 ms	0.4 ms
	CJ1W-NC881	When 8 axes and 4 task are used	2.0 ms	0.5 ms	0.4 ms	0.5 ms
	CJ1W-NCF81	When 16 axes and 4 task are used	2.0 ms	1.0 ms	0.5 ms	0.7 ms
	CJ1W-NC482	When 4 axes and 4 task are used Remote I/O: 20 input words and 20 output words	1.0 ms	0.25 ms	0.3 ms	0.4 ms
		When 4 axes and 4 task are used Remote I/O: 100 input words and 100 output words	2.0 ms	0.5 ms	0.3 ms	0.5 ms
		When 4 axes and 4 task are used Remote I/O: 640 input words and 640 output words	4.0 ms	1.0 ms	0.7 ms	1.0 ms
	CJ1W-NC882	When 8 axes and 4 task are used Remote I/O: 20 input words and 20 output words	2.0 ms	0.5 ms	0.4 ms	0.5 ms
		When 8 axes and 4 task are used Remote I/O: 100 input words and 100 output words	2.0 ms	0.5 ms	0.4 ms	0.5 ms
		When 8 axes and 4 task are used Remote I/O: 640 input words and 640 output words	4.0 ms	1.0 ms	0.8 ms	1.1 ms
	CJ1W-NCF82	When 16 axes and 4 task are used Remote I/O: 20 input words and 20 output words	3.0 ms	1.0 ms	0.5 ms	0.7 ms
		When 16 axes and 4 task are used Remote I/O: 100 input words and 100 output words	3.0 ms	1.0 ms	0.5 ms	0.7 ms
		When 16 axes and 4 task are used Remote I/O: 640 input words and 640 output words	4.0 ms	1.0 ms	0.9 ms	1.3 ms

Note. These control cycles and communications cycles are only examples. Actual values will depend on the models and number of slaves that are connected.

Appendix-2 Comparison to Previous Position Control Units

This appendix provides a comparison of the PCU to previous models.

Comparison to Previous Models

The differences between these PCUs are given in the following table: CJ1W-NC□81/□82, CJ1W-NC□□4, and CJ1W-NC□71.

Function/performance	CJ1W-NC281/481/881/ F81/482/882/F82	CJ1W-NC214/234/414/434	CJ1W-NC271/471/F71
Controlled axes per Unit	2, 4, 8, 16	2, 4	2, 4, 16
Number of mountable Units	10 Units max. per Rack 16 Units total	5 Units max. per Rack 20 Units total (words for two unit numbers used)	10 Units max. per Rack 16 Units total
Controllable actuators	OMNUC G5-series Servomotors with EtherCAT	Pulse-input servomotors, linear motors, DD motors, stepping motors	OMNUC G5-series, G-series, or W-series Servomotors with MECHATROLINK-II
Output method	EtherCAT	Pulse output NC□14: Open collector NC□34: Line driver	MECHATROLINK-II
Connection distance	Max. between nodes: 100 m	NC□14: 3m max. NC□34: 10m max.	Maximum total length: 100 m (with repeater)
Language	Ladder diagram		
Memory operation	Supported	Supported	—
Processing cycle	Normal operation: 0.5 ms (1 to 2 controlled axes) 1 ms (3 to 4 controlled axes) 2 ms (5 to 16 controlled axes)	Normal operation: 1 ms Synchronous operation: CPU Unit sync cycle	1 to 4 axes: 1 ms 5 to 10 axes: 2 ms 11 to 16 axes: 4 ms
Starting time* ¹	High-speed starting instruction (starting 1 axis): 0.4 ms max. Normal starting (direct operation): 1.5 to 5.0 ms	High-speed starting instruction (starting 1 axis): 0.1 ms max Normal starting (direct operation): 1 to 3 ms	Maximum response time: 4.625 ms
Encoder pulse count (feedback present position)	Supported (EtherCAT)	Supported (Phases A and B 1 MHz (x1) phase Z)	Supported (MECHATROLINK-II)
Absolute encoder	Supported (G5 Series)	Supported (G5/G/W Series)	Supported (G5/G/W Series)

A

Appendix

Appendix-2 Comparison to Previous Position Control Units

Function/performance		CJ1W-NC281/481/881/ F81/482/882/F82	CJ1W-NC214/234/414/434	CJ1W-NC271/471/F71
Positioning functions	Position setting range	-2147483648 to 2147483647		
	Control units	Pulses, millimeters, inches, or degrees	Pulses, millimeters, inches, or degrees	Any unit using electronic gear
	Linear interpolation	Supported (4 axes max. × 2 sets)	Supported (4 axes for NC414/NC434)	Supported (4 axes max. × 2 sets)
	Circular interpolation	Supported (2 axes)	Supported (2 axes)	–
	Target position changes	Supported	Supported	Supported
	Infinite axes	Supported (rotation coordinates)	Supported (rotation coordinates)	–
	Interrupt feeding	Supported	Supported	Supported
Synchronization	Electronic cam	–	Supported	–
	Phase compensation	–	Supported	–
	Additive axis operation	Supported (via electric shaft auxiliary axis) ^{*2}	Supported	–
	Resist function/ latching function	Supported ^{*2}	Supported	–
	Electric shaft	Supported ^{*2}	Supported	–
S-curve acceleration/deceleration	Supported	Supported	Supported	
M Code	Supported	Supported	–	
MPG	–	Supported	–	
Positioning data quantity	500 per axis	500 per axis	1 (direct operation from ladder diagram in CPU Unit)	
Virtual axes	Supported (Function switching for physical axes)	Supported	–	
Speed control (CSP)	Supported ^{*2}	Supported	–	
Speed control (CSV)	Supported ^{*2}	–	Supported	
Position/speed switching control during operation	Supported	Supported	Supported	
Torque control	Supported ^{*2}	–	Supported	
Speed/torque switching control during operation	–	–	Supported	
Position/torque switching control during operation	–	–	Supported	
Origin searches	Supported (origin sensor and stopper)	Supported (origin sensor and stopper)	Supported (origin sensor)	

A

Appendix

Appendix-2 Comparison to Previous Position Control Units

Function/performance		CJ1W-NC281/481/881/ F81/482/882/F82	CJ1W-NC214/234/414/434	CJ1W-NC271/471/F71
Backlash compensation		Supported (using Servo Drive function)	Supported	Supported (using Servo Drive function)
Teaching		Supported	Supported	–
Com- mands for operation	Operating areas	Each of the areas given below is used for the functions for the number of axes used. <ul style="list-style-type: none"> ♦ PCU Control Memory Area ♦ Manual Operation Command Memory Area ♦ Direct Operation Command Memory Area ♦ Axis Status Memory Area ♦ Memory Operation Command Memory Area ♦ Memory Operation Status Memory Area ♦ Expanded Monitor Memory Area 	Each of the areas given below is used for the functions for the number of axes used. <ul style="list-style-type: none"> ♦ PCU Control Memory Area ♦ Manual Operation Command Memory Area ♦ Direct Operation Command Memory Area ♦ Axis Status Memory Area ♦ Memory Operation Command Memory Area ♦ Memory Operation Status Memory Area 	The following areas are used for the number of axes that are used. <ul style="list-style-type: none"> ♦ Axis Operation Output Memory Areas ♦ Axis Operation Input Memory Areas
Com- mands for operation	Setting ar- eas	PCU Control Memory Area: CPU Bus Unit Area Manual Operation Command Memory Area, Direct Operation Command Memory Area, Axis Status Memory Area, Memory Operation Command Memory Area, Memory Operation Status Memory Area, and Expanded Monitor Memory Area: You can set each of these in any of these areas: CIO, WR, DM and EM.	PCU Control Memory Area: Special I/O Unit Memory Area Manual Operation Command Memory Area, Direct Operation Command Memory Area, Axis Status Memory Area, Memory Operation Command Memory Area, and Memory Operation Status Memory Area: You can set each of these in any of these areas: CIO, WR, DM and EM.	Words for general operation: CPU Bus Unit Area The Axis Operation Output Areas and Axis Operation Input Areas can be set in any words in the CIO, WR, DM, or EM Area.

*1. The starting time depends on the control cycle, communications cycle, and operating conditions. For details, refer to *Command Response Time* on page A-1.

*2. Supported in unit version 1.3 or later for CJ1W-NC□82.

A

Appendix

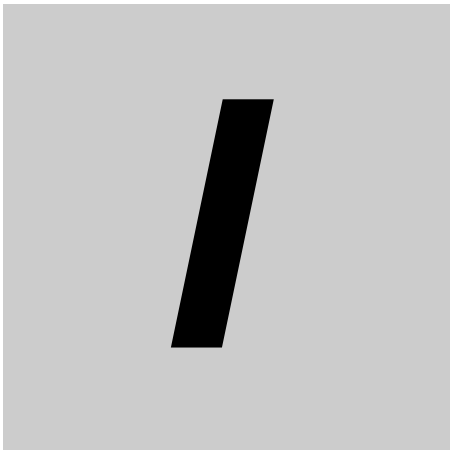

Index



Index

A

Absolute encoder	
Origin Position Offset.....	6-58
origin setting	5-49
Rotation Axis Offset Automatic Save Setting...	6-25
setup	5-51
Acceleration Time.....	6-161
Acceleration/Deceleration.....	8-60
Acceleration/Deceleration Curve Selection	5-19, 6-37
Acceleration/Deceleration Operation with Short Movement	7-26
acceleration/deceleration setting	5-19, 6-36
acceleration/deceleration time.....	7-24, 8-61
acceleration/deceleration time for multi-starting	7-25
acceleration/deceleration time in continuous positioning.....	8-62
Acceleration/Deceleration Time Selection.....	5-20, 6-38
All Synchronized Unit Stop Bit.....	11-7
automatic network setup.....	1-16, 2-18
Auxiliary Axis Option Setting	6-69
Axis Feeding Mode.....	5-16, 6-41
axis parameter addresses	9-12
axis parameters	6-29
Axis Specification	6-157
Axis Status during Continuous Operation.....	8-46
Axis Status Memory Area.....	6-100
Axis Status Memory Area Selection	6-19
Axis Type.....	6-32
axis type setting.....	5-15

B

backing up data	9-62
basic operating procedures	1-11

C

CAN application protocol over EtherCAT (CoE).....	2-1
characteristics.....	1-20
circular interpolation	6-157, 8-53
circular center specification.....	6-161, 8-53
passing point specification.....	6-161, 8-53
radius specification	6-161, 8-53
command.....	6-152
circular interpolation.....	8-32
END	8-28
FOR	8-26
interrupt feeding	
positioning operation	8-36
speed control.....	8-37
JUMP	8-25
linear interpolation operation.....	8-31
NEXT	8-26
NOP	8-25
operation commands	6-153
positioning operation (PTP)	8-29
PRSET	8-28
PSET	8-27
sequence commands.....	6-152
speed control	8-35
command position unit setting.....	5-15, 6-40
command positions.....	6-152

Command Present Position Overflow.....	13-54
Command Pulse Count Per Motor Rotation.....	5-16, 6-42
Command speed	6-161
common parameter addresses.....	9-10
common parameters.....	6-15
Communications Status.....	2-4
conditional expressions	6-165
configuration axis settings	6-72, 8-3
Constant	6-167
control cycle.....	6-12
control I/O connector (CN1)	
connection example	3-11
Counter.....	6-167
CPU Bus Unit Area.....	3-4
CX-Programmer	
data transfer.....	9-2, 9-54
manual operation	4-14
monitoring	7-39, 8-78
origin search	5-46
setting parameters	6-9
wiring check	3-15
cycle time.....	A-6

D

data 1 area selection	6-166
data 1 bit.....	6-166
data 1 word offset.....	6-166
data 2 area selection	6-166
data 2 bit.....	6-167
data 2 word offset.....	6-167
Data Addresses.....	9-4
Data Checks	9-28
data transfer	9-1, 9-30
data transfer bits.....	9-1, 9-28, 9-31, 9-39
Deceleration Time	6-161
Deviation between Axes Limit Value	6-74, 10-5
Deviation between Axes Monitor Enable.....	6-74
Deviation between Axes Monitor Setting.....	6-74
Deviation between Axes Monitor Target Axis.....	6-74
Deviation Counter Reset Bit	8-48
Deviation Monitor Function Settings.....	6-61, 10-4
dimensions	3-7
direct operation	
Axis Status Memory Area	7-5
Combinations for Multi-starting	7-14
Direct Operation Command Memory Area.....	7-3
Manual Operation Command Memory Area	7-2
Multi-starting Operations.....	7-13, 7-14
operations	7-12
Outline.....	7-1
Start	7-12
Direct Operation Command Memory Area	6-91
Direct Operation Command Memory Area Selection.....	6-18
Display Selection	5-16
Displayed Unit	6-42
distributed clocks (DCs).....	2-2
Drive Alarm Reset Output Time.....	6-35
dwel timer	6-156, 8-39

E	
EC Directive.....	1-34
edge selection	6-166
Electric Shaft	11-12
EMC Directive.....	1-34
Encoder Type	6-57
End Pattern.....	6-154, 8-42
automatic	6-154, 8-42
continuous 1	6-155, 8-43
continuous 2	6-155, 8-43
continuous 3	6-155, 8-44
individual.....	6-154, 8-42
error code	13-38, 13-40
Error Enable for Undetected Interrupt Input	6-162
error flag	13-34, 13-38
error indications as a CPU Bus Unit	13-61
error indicators.....	13-16
EtherCAT	
communications cable connection method.....	3-13
communications cables.....	3-9, 3-10
communications connector	3-3, 3-8
communications cycle.....	6-12
communications functions.....	2-4
remote I/O master function.....	2-4
Servo Drive control.....	2-4
communications settings.....	2-2, 6-11
communications specifications	1-26
communications status	2-11
relationship between axes and slaves	2-8
wiring, communications.....	3-9
Example of Acceleration/ Deceleration Operation...	7-24
exceeding	5-19
Executing a Data Save Operation	9-57
Expanded Monitor	
Memory Area Selection.....	6-21
memory areas	6-118
settings	6-59
Type	6-60
Type Settings.....	10-3
external interrupt response time.....	A-2
F	
Feedback Input Settings.....	6-57
feedback position counter.....	10-1
Feedback Position Monitoring	10-1
Feedback Present Position Overflow	13-54
feedback pulse input settings	10-3
Feedback Speed Sampling Cycle	6-62
forced output.....	6-153
forced output (PSET).....	8-27
functional specifications.....	1-27
G	
general specifications	1-19
H	
high-speed PTP.....	7-18
instructions.....	7-19

IOWR(223) instruction	7-20
NCDMV(218) instruction.....	7-19

I	
I/O function selection.....	6-34
I/O function setting.....	5-18
Inching	4-11
Inching Width.....	6-56
Inching width.....	4-7
indicators	3-1
Individual Start Bit.....	8-56
Initializing Mode.....	4-1, 9-30, 9-60
Input Data Clear Mode for	
Communications Error.....	6-26
installation method.....	3-5
Interpolation Acceleration Time	6-159, 8-52
Interpolation Acceleration/	
Deceleration Curve Selection	6-159
Interpolation Acceleration/	
Deceleration Time Selection.....	6-160, 8-52
Interpolation Axis Stop Method.....	6-73
Interpolation Deceleration Time.....	6-159, 8-52
Interpolation Speed	6-158
interpolation speed specification method	6-161
Interpolation Starting Speed	6-159
Interrupt Feeding	10-7
Interrupt Feeding Amount.....	6-162
Interrupt Feeding in Direct Operation	10-9
interrupt feeding settings	6-50
IORD(222) instruction.....	9-50
specifications	9-50
IOWR(223) instruction.....	9-29, 9-45
specifications	9-46
items to inspect periodically.....	14-1
J	
Jogging	4-3
Jogging Acceleration Time	4-7, 6-56
Jogging Deceleration Time.....	4-7, 6-56
jogging/inching settings	4-6, 6-56
Jogging/inching speeds	4-7, 6-56
jump.....	6-153
jump destination sequence number.....	6-153
L	
Limit Input Stop Method.....	6-34
Linear Axis (Finite Length).....	6-41
linear interpolation	8-50
speed	8-51
M	
M code.....	6-156, 8-40
Manual Operation Command Memory Area	6-89
Manual Operation Command Memory Area	
Selection.....	6-17
maximum speed	5-19, 6-36
maximum torque.....	6-58

Index

memory areas.....	6-2
memory operation.....	8-1, 8-58
Axis Status Memory Area	8-14
command	8-25
Deceleration Stop Bit	8-47
Enabled Flag.....	8-56
Individual Start.....	6-115, 8-56
interrupt feeding.....	10-12
Manual Operation Command Memory Area	8-13
monitoring	8-78
operations	8-24
parameter	6-72
addresses.....	9-16
preview	8-79
Start	6-115, 8-24
stopping operation	8-46
Memory Operation Command	
Memory Area.....	6-114, 8-20
Memory Operation Command	
Memory Area Selection	6-18
Memory Operation Condition Data	8-10
memory operation condition data	6-163
addresses	9-23
Memory Operation Data	6-3, 6-147, 8-6
addresses	9-16
Memory Operation Status Memory Area.....	6-115, 8-21
Memory Operation Status Memory Area	
Selection.....	6-20
Memory Operation Stop Bit	8-46
multi-starting operations	7-13
Multi-starting with Fixed Acceleration/ Deceleration Time	7-27

N

NCDMV(218) instruction.....	7-19
network configuration settings.....	2-15
Normal Operation Mode	4-2, 9-30, 9-60

O

object dictionary.....	2-1
online connection.....	1-13
operating modes.....	4-1, 9-30, 9-60
Operation at Forward Limit Input.....	5-23, 6-52
Operation at Reverse Limit Input.....	5-23, 6-52
Operation at Reverse Rotation Command	6-37
Operation Memory Area	6-75, 6-76
Operation Memory Area Allocation Settings.....	6-17
Origin Compensation.....	5-40
Origin Compensation Value.....	5-25, 6-53
Origin Input Detection Direction.....	5-24, 6-53
Origin Input Mask Amount.....	5-24, 6-53
Origin Position Latch	5-23, 5-40, 10-31
Origin Position Offset.....	5-25, 6-54
Origin Preset.....	5-39, 5-44
origin return	5-1, 5-54
Acceleration Time	5-55, 6-55
Deceleration Time.....	5-55, 6-55
settings	5-54, 6-55
speed	5-54, 6-55
origin search	5-1, 5-3, 5-26
acceleration time.....	5-25, 6-54

approach speed	5-25, 6-54
Compensation Speed	5-25, 6-54
deceleration time.....	5-25, 6-54
holding time.....	5-24
Operation Mode	5-23, 6-52
settings.....	5-22, 6-51
speed	5-25, 6-54
start direction	5-23, 6-52
Origin Search Operations	5-26
Limit Input OFF	5-33
No Origin Proximity Input.....	5-32
No Origin Proximity Input and Holding Origin Input.....	5-38
No Origin Reverse Turn and Origin Proximity Input.....	5-32
Origin Preset.....	5-39
Origin Proximity Input OFF	5-30
Origin Proximity Input ON	5-31
Origin Proximity Input Only	5-35
Proximity Reverse Turn and Holding Origin Input.....	5-37
Proximity Reverse Turn and Origin Input Mask Amount	5-34
Proximity Reverse Turn and Origin Proximity Input OFF	5-27
Proximity Reverse Turn and Origin Proximity Input OFF (Approach Speed after Reverse Turn).....	5-28
Proximity Reverse Turn and Origin Proximity Input ON	5-27
Proximity Reverse Turn and Origin Proximity Input ON (Approach Speed After Reverse Turn)	5-29
Proximity Reverse Turn/Holding Time	5-36
Other Addresses.....	9-24
Output Direction.....	5-21, 6-39
output settings	5-21, 6-39
Output Signal.....	6-153
overflows	13-54
override.....	10-13
Override Enable Bit	10-13

P

parameters	6-2
part names.....	3-1
Pass Flag.....	8-46
PCU Control Input Memory Area	9-32, 9-40
PCU Control Memory Input Area.....	6-80
PCU Control Output Memory Area.....	6-79, 9-31, 9-39
PCU Ready Flag.....	4-1, 9-30, 9-60, A-1
PCU setup	9-59
PCU Setup Flag.....	4-1, 9-30, 9-60
PCU Setup Mode.....	4-1, 9-30, 9-60
Position Deviation Limit Value	6-63
Position Deviation Monitor Valid	6-62
position specification	6-158
Positioning	
Monitoring Time	6-35
TRIGGER instruction	6-168
positioning completion	10-25
Input Monitor Valid	6-156, 8-40
width settings	6-63
positioning functions	1-5

Present Position Latch.....	10-28
present position preset.....	5-1, 5-44
process data objects.....	2-1
process data objects (PDOs).....	2-1
proximity holding time.....	6-53
PRSET.....	8-28

R

Read Data Bit.....	9-39
Relation between Allocated Areas of Memory.....	6-3
Remote I/O Communications Status Memory Area Selection.....	6-24
Remote I/O Input Memory Area Selection.....	6-23
Remote I/O Output Memory Area Selection.....	6-22
repeat condition.....	6-153
Repeat Loop Number.....	6-153
resetting errors.....	13-55
restart bits.....	13-61
restoring data.....	9-63
Rotation Axis (Infinite Length).....	6-41
Rotation Axis Direction.....	6-161
Rotation Axis Upper Limit.....	5-16, 6-42

S

Save Data Bit.....	9-57
Saving Data.....	9-3, 9-56
sequence.....	8-4
Sequence Number Enable Bit.....	8-55
Sequence Skip Condition.....	6-154, 8-39
Sequence Start Condition.....	6-153
service data objects.....	2-1
service data objects (SDOs).....	2-1
Servo Unlock Bit.....	8-48
Setting Conditions.....	8-39
Setting I/O tables.....	1-14
Simple Backup.....	9-61
Single Axis Deceleration Time at Interpolation.....	6-39
Software Limit Function.....	6-47
Software limit settings.....	5-21
software limit settings.....	6-46
Speed Deviation Limit Value.....	6-63
Speed Deviation Monitor Dwell Time.....	6-62
Speed Deviation Monitor Valid.....	6-62
start condition.....	8-39
Starting Present Position Clear Enable.....	5-44
Starting Present Position Clear Enable Setting.....	6-45
Starting Speed.....	5-19, 6-36
starting time.....	A-1
Support Software-controlled Mode.....	4-1, 9-30, 9-60
Synchronous Data Link.....	11-1
area.....	11-5
memory area allocations.....	11-5
reception error.....	11-10
reception warning.....	11-10
Setting Procedure.....	11-2
Settings.....	6-64
Synchronous Feeding Auxiliary Axis Command Data Offset.....	6-69
Synchronous Feeding Auxiliary Axis Selection.....	6-69
Synchronous Feeding Position	

Function Selection.....	6-66
Master Axis Multiplier.....	6-69
Master Axis No.....	6-66
Settings.....	6-66
synchronous feeding position.....	11-12
bilateral operation.....	11-13
Deceleration Stop Bit.....	11-15
differential gear.....	11-18
filter constant.....	11-21
master axis multiplier.....	11-16
output filter.....	11-20
procedure.....	11-14
torque option function.....	11-22
synchronous feeding torque.....	11-31
command data offset.....	6-67, 11-33
Deceleration Stop Bit.....	11-33
function selection.....	6-67, 11-33
procedure.....	11-32
settings.....	6-67, 11-33
velocity limitation option.....	11-34
synchronous feeding torque option command data offset.....	6-67, 11-24, 11-30
synchronous feeding torque option selection.....	6-67, 11-24, 11-30
synchronous feeding velocity.....	11-25
command data offset.....	11-27
command data offset.....	6-66
Deceleration Stop Bit.....	11-27
function selection.....	6-66, 11-27
procedure.....	11-26
settings.....	6-66, 11-27
torque option function.....	11-28
synchronous feeding velocity limitation option.....	6-68, 11-35
synchronous feeding velocity limitation selection.....	6-68, 11-35
synchronous feeding velocity limitation value offset.....	6-68, 11-35
Synchronous Group Stop Bit.....	11-8
Synchronous Group Stop Selection.....	6-64, 11-8
synchronous time monitoring timeout.....	11-10
system configuration.....	1-4

T

tasks.....	6-71, 8-1
teaching.....	10-23
Teaching Setting.....	6-73
timer.....	6-167
Timing of Data Changes.....	8-59
torque limits.....	10-19
Torque Settings.....	6-58
transferring data with IOWR(223) and IORD(222) instructions.....	9-2
troubleshooting	
problems and countermeasures.....	13-4
troubleshooting flowcharts.....	13-2

U

underflows.....	13-54
Unit Multiplier.....	5-17, 6-44
unit number switch.....	3-3

Index

unit version 1-29
unused axes 3-14

V

Verification 9-64
Virtual axes 6-33

W

warning reset bit 13-56
warnings 13-30, 13-50, 13-54
Work Travel Distance per Motor Rotation 5-16, 6-42
Write Data Bit 9-31

Z

zone function 6-49
 linear axis 6-49
 rotation axis 6-50
Zone Settings 6-48

OMRON Corporation Industrial Automation Company

Tokyo, JAPAN

Contact: www.ia.omron.com

Regional Headquarters

OMRON EUROPE B.V.

Wegalaan 67-69, 2132 JD Hoofddorp
The Netherlands
Tel: (31)2356-81-300/Fax: (31)2356-81-388

OMRON ELECTRONICS LLC

2895 Greenspoint Parkway, Suite 200
Hoffman Estates, IL 60169 U.S.A
Tel: (1) 847-843-7900/Fax: (1) 847-843-7787

OMRON ASIA PACIFIC PTE. LTD.

No. 438A Alexandra Road # 05-05/08 (Lobby 2),
Alexandra Technopark,
Singapore 119967
Tel: (65) 6835-3011/Fax: (65) 6835-2711

OMRON (CHINA) CO., LTD.

Room 2211, Bank of China Tower,
200 Yin Cheng Zhong Road,
PuDong New Area, Shanghai, 200120, China
Tel: (86) 21-5037-2222/Fax: (86) 21-5037-2200

Authorized Distributor:

© OMRON Corporation 2010 All Rights Reserved.
In the interest of product improvement,
specifications are subject to change without notice.

Cat. No. W487-E1-05

0814