

RFID System

V680 Series

User's Manual

ID Sensor Units

CS1W-V680C11

CS1W-V680C12

CJ1W-V680C11

CJ1W-V680C12

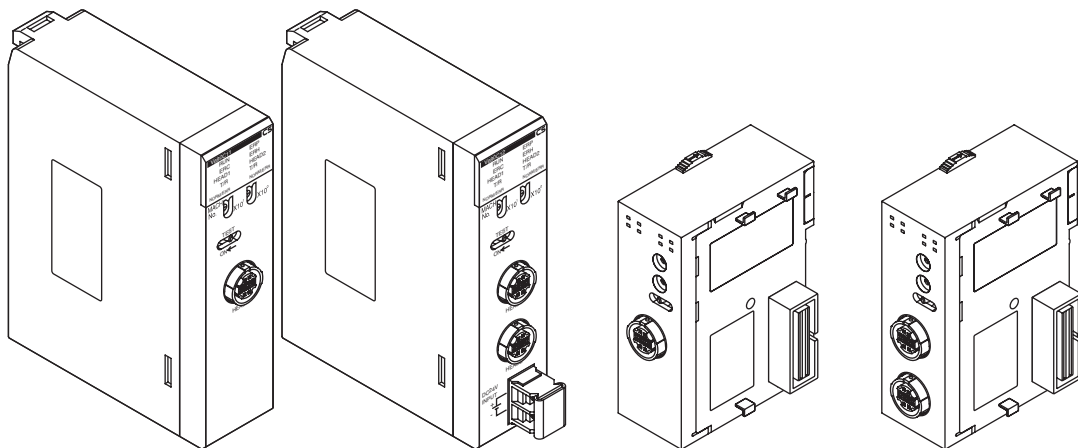

Introduction

Thank you for purchasing an ID Sensor Unit for a V680-series RFID System. This manual describes the functions, performance, and application methods needed for optimum use of your V680-series RFID System.

Please observe the following items when using the V680-series RFID System.

- Allow the V680-series RFID System to be installed and operated only by qualified specialist with a sufficient knowledge of electrical systems.
- Read and understand this manual before attempting to use the V680-series RFID System and use the V680-series RFID System correctly.
- Keep this manual in a safe and accessible location so that it is available for reference when required.

Introduction	READ AND UNDERSTAND THIS DOCUMENT	Introduction
Section 1	Features and System Configuration	SECTION 1
Section 2	CS-series ID Sensor Units	SECTION 2
Section 3	CJ-series ID Sensor Units	SECTION 3
Section 4	Data Exchange with the CPU Unit	SECTION 4
Section 5	ID Sensor Unit Functions	SECTION 5
Section 6	Controlling the ID Sensor Unit	SECTION 6
Section 7	Troubleshooting Alarms and Errors	SECTION 7
Section 8	Appendices	SECTION 8

RFID System

CS1W-V680C11 ID Sensor Unit
 CS1W-V680C12 ID Sensor Unit
 CJ1W-V680C11 ID Sensor Unit
 CJ1W-V680C12 ID Sensor Unit

User's Manual

READ AND UNDERSTAND THIS DOCUMENT

Please read and understand this document before using the products. Please consult your OMRON representative if you have any questions or comments.

WARRANTY

OMRON's exclusive warranty is that the products are free from defects in materials and workmanship for a period of one year (or other period if specified) from date of sale by OMRON.

OMRON MAKES NO WARRANTY OR REPRESENTATION, EXPRESS OR IMPLIED, REGARDING NON-INFRINGEMENT, MERCHANTABILITY, OR FITNESS FOR PARTICULAR PURPOSE OF THE PRODUCTS. ANY BUYER OR USER ACKNOWLEDGES THAT THE BUYER OR USER ALONE HAS DETERMINED THAT THE PRODUCTS WILL SUITABLY MEET THE REQUIREMENTS OF THEIR INTENDED USE. OMRON DISCLAIMS ALL OTHER WARRANTIES, EXPRESS OR IMPLIED.

LIMITATIONS OF LIABILITY

OMRON SHALL NOT BE RESPONSIBLE FOR SPECIAL, INDIRECT, OR CONSEQUENTIAL DAMAGES, LOSS OF PROFITS OR COMMERCIAL LOSS IN ANY WAY CONNECTED WITH THE PRODUCTS, WHETHER SUCH CLAIM IS BASED ON CONTRACT, WARRANTY, NEGLIGENCE, OR STRICT LIABILITY.

In no event shall responsibility of OMRON for any act exceed the individual price of the product on which liability is asserted.

IN NO EVENT SHALL OMRON BE RESPONSIBLE FOR WARRANTY, REPAIR, OR OTHER CLAIMS REGARDING THE PRODUCTS UNLESS OMRON'S ANALYSIS CONFIRMS THAT THE PRODUCTS WERE PROPERLY HANDLED, STORED, INSTALLED, AND MAINTAINED AND NOT SUBJECT TO CONTAMINATION, ABUSE, MISUSE, OR INAPPROPRIATE MODIFICATION OR REPAIR.

SUITABILITY FOR USE

THE PRODUCTS CONTAINED IN THIS DOCUMENT ARE NOT SAFETY RATED. THEY ARE NOT DESIGNED OR RATED FOR ENSURING SAFETY OF PERSONS, AND SHOULD NOT BE RELIED UPON AS A SAFETY COMPONENT OR PROTECTIVE DEVICE FOR SUCH PURPOSES. Please refer to separate catalogs for OMRON's safety rated products.

OMRON shall not be responsible for conformity with any standards, codes, or regulations that apply to the combination of products in the customer's application or use of the product.

At the customer's request, OMRON will provide applicable third party certification documents identifying ratings and limitations of use that apply to the products. This information by itself is not sufficient for a complete determination of the suitability of the products in combination with the end product, machine, system, or other application or use.

The following are some examples of applications for which particular attention must be given. This is not intended to be an exhaustive list of all possible uses of the products, nor is it intended to imply that the uses listed may be suitable for the products:

- Outdoor use, uses involving potential chemical contamination or electrical interference, or conditions or uses not described in this document.
- Nuclear energy control systems, combustion systems, railroad systems, aviation systems, medical equipment, amusement machines, vehicles, safety equipment, and installations subject to separate industry or government regulations.
- Systems, machines, and equipment that could present a risk to life or property.

Please know and observe all prohibitions of use applicable to the products.

NEVER USE THE PRODUCTS FOR AN APPLICATION INVOLVING SERIOUS RISK TO LIFE OR PROPERTY WITHOUT ENSURING THAT THE SYSTEM AS A WHOLE HAS BEEN DESIGNED TO ADDRESS THE RISKS, AND THAT THE OMRON PRODUCT IS PROPERLY RATED AND INSTALLED FOR THE INTENDED USE WITHIN THE OVERALL EQUIPMENT OR SYSTEM.

PERFORMANCE DATA

Performance data given in this document is provided as a guide for the user in determining suitability and does not constitute a warranty. It may represent the result of OMRON's test conditions, and the users must correlate it to actual application requirements. Actual performance is subject to the OMRON Warranty and Limitations of Liability.

CHANGE IN SPECIFICATIONS

Product specifications and accessories may be changed at any time based on improvements and other reasons.

It is our practice to change model numbers when published ratings or features are changed, or when significant construction changes are made. However, some specifications of the product may be changed without any notice. When in doubt, special model numbers may be assigned to fix or establish key specifications for your application on your request. Please consult with your OMRON representative at any time to confirm actual specifications of purchased products.

DIMENSIONS AND WEIGHTS

Dimensions and weights are nominal and are not to be used for manufacturing purposes, even when tolerances are shown.

ERRORS AND OMISSIONS

The information in this document has been carefully checked and is believed to be accurate; however, no responsibility is assumed for clerical, typographical, or proofreading errors, or omissions.

PROGRAMMABLE PRODUCTS

OMRON shall not be responsible for the user's programming of a programmable product, or any consequence thereof.

COPYRIGHT AND COPY PERMISSION

This document shall not be copied for sales or promotions without permission.



This document is protected by copyright and is intended solely for use in conjunction with the product. Please notify us before copying or reproducing this document in any manner, for any other purpose. If copying or transmitting this document to another, please copy or transmit it in its entirety.

Safety Precautions





- Signal Words Used in This Manual

The following signal words and symbols are used in this manual to indicate precautions that must be observed to ensure safe use of the V680-series ID Sensor Unit. The precautions provided here contain important safety information. You must observe these precautions.

The following signal words and symbols are used in this manual.

 WARNING	Indicates a potentially hazardous situation which, if not avoided, will result in minor or moderate injury, or may result in serious injury or death. Additionally there may be significant property damage.
 CAUTION	Indicates a potentially hazardous situation which, if not avoided, may result in minor or moderate injury or in property damage.

- Meanings of Alert Symbols

	General Caution Indicates general cautionary, warning, or danger level information.
	Electrical Shock Caution Indicates possibility of electric shock under specific conditions.
	General Prohibition Indicates a general prohibition.
	Disassembly Prohibition Indicates that disassembly is prohibited to prevent electric shock.
	General Mandatory Action Indicates a general action that must be performed by the user.

- Warnings

WARNING

Never attempt to disassemble any Units while power is being supplied. Doing so may result in serious electrical shock or electrocution.



Never touch any of the terminals while power is being supplied. Doing so may result in serious electrical shock or electrocution.



Provide safety measures in external circuits, i.e., not in the PLC (CPU Unit including associated Units), in order to ensure safety in the system if an abnormality occurs due to malfunction of the PLC or another external factor affecting the PLC operation. Not doing so may result in serious accidents.

- Emergency stop circuits, interlock circuits, limit circuits, and similar safety measures must be provided in external control circuits.
- The PLC will turn OFF all outputs when its self-diagnosis function detects any error or when a severe failure alarm (FALS) instruction is executed. As a countermeasure for such errors, external safety measures must be provided to ensure safety in the system.
- The PLC outputs may remain ON or OFF due to deposition or burning of the output relays or destruction of the output transistors. As a countermeasure for such problems, external safety measures must be provided to ensure safety in the system.



This Product is not designed or rated for ensuring safety of persons. Do not use it for such purposes.



CAUTION

Execute online edit only after confirming that no adverse effects will be caused by extending the cycle time. Otherwise, the input signals may not be readable.



Regulations and Standards

The V680-series ID Sensor Unit conforms to the following international regulations and standards.

1. EMC Standards

The V680-series ID Sensor Unit meets EMC requirements.

EMC Standard: EN 61000-6-2

EN 61000-6-4

Connect to either circuit type (1) or (2) listed below.

(1) Limited Voltage/Current Circuit (Approved under UL 508)

A circuit that uses the secondary windings of an isolation transformer as its power supply and fulfills the following conditions:

- Maximum voltage (with no load): 30 Vrms (42.4 V peak)
and
- Maximum current: (a) 8 A (including short-circuits) or
(b) Current limited by a circuit protection device (e.g., fuse) with the ratings listed in the following table.

No-load voltage (Vrms)	Maximum current rating (A)
0 to 20	5.0
Over 20 to 30	100 Peak voltage

- (2) A class 2 circuit with a maximum voltage of 30 Vrms (42.4 V peak) that uses a class 2 power supply conforming to UL 1310 or a class 2 transformer conforming to UL 1585 as its power source.

Precautions for Safe Use

Be sure to observe the following precautions to ensure safe use of the Product.

1. Do not attempt to disassemble, repair, or modify the Product.
2. Tighten the Backplane mounting screws and terminal block screws securely.
3. Be sure to use crimp terminals of the specified size for wiring.
4. If any cable has a locking mechanism, make sure that it has been locked before using the cable.
5. Make sure the power supplied by the DC Power Supply Unit is within the rated power supply voltage (24 VDC +10%/–15%) before using the Product.
6. When using the CS1W-V680C12, make sure the power supplied by the DC power supply for external inputs is within the rated power supply voltage (24 VDC +10%/–15%) before using the Product.
7. Do not connect the power supply in reverse.
8. Use crimp terminals for wiring. Do not connect bare stranded wires directly to terminals.
9. Do not allow water or wires to enter the Product through gaps in the case. Otherwise, fire or electric shock may occur.
10. Turn OFF the power to the Product before attaching or removing an Amplifier or Antenna.
11. If multiple Antennas are mounted near each other, communications performance may decrease due to mutual interference. Refer to information on installing Antenna in the RFID System V680 Series User's Manual for Amplifiers, Antennas, and ID Tags (FRAM) (Cat. No. Z248), V680 Series RFID System Amplifier/Tags (EEPROM) User's Manual (Cat. No. Z262), and Heat-resistive RFID System V680 Series User's Manual (Cat. No. Z221) and check to make sure there is no mutual interference.
12. If an error is detected in the Product, immediately stop operation and turn OFF the power supply. Consult with an OMRON representative.
13. Dispose of the Product as industrial waste.
14. Observe all warnings and precautions given in the body of this manual.
15. Do not use thinners, benzenes, acetones, and kerosenes for cleaning.

Precautions for Correct Use

Always observe the following precautions to prevent operation failure, malfunctions, and adverse effects on performance and equipment.

1. Installation Environment

Do not use the Product in the following locations.

- Locations exposed to any flammable, explosive, or corrosive gasses
- Locations exposed to dust, metallic powder, or salts
- Locations not within the specified operating temperature range
- Locations subject to rapid changes in temperature or condensation
- Locations not within the specified operating humidity range
- Locations subject to direct vibration or shock outside the specified ranges
- Locations subject to spray of water, oil, or chemicals

2. Installation

- This Product uses a frequency band of 13.56 MHz to communicate with ID Tags. Some transceivers, motors, inverters, switching power supplies, etc., generate electrical noise that will affect these communications. If any of these devices are located in the vicinity of the Product, they may affect communications with ID Tags, and may possibly damage the ID Tags. Prior to using the Product in the vicinity of any of these devices, perform a test to determine whether the Product can be used under the resulting influence.
- Observe the following precautions to minimize the effects of normal noise.
 - (1) Ground the ground terminal on the Product and all metal objects in the vicinity of the Product to 100 Ω or less.
 - (2) Do not use the Product near high-voltage or high-current lines.
- The Product is not waterproof. Do not use it in an environment where mist is present.
- Do not expose the Product to chemicals that adversely affect the Product materials.
- Use a tightening torque of 0.4 N·m when mounting the Product.

3. Storage

- Locations exposed to any flammable, explosive, or corrosive gasses
- Locations exposed to dust, metallic powder, or salts
- Locations not within the specified operating temperature range
- Locations subject to rapid changes in temperature or condensation
- Locations not within the specified operating humidity range
- Locations subject to direct vibration or shock outside the specified ranges
- Locations subject to spray of water, oil, or chemicals

Precautions for Users of V600-series ID Sensor Units

■ Differences between the V600-series and V680-series ID Sensor Units

The following features were added to the V680-series ID Sensor Units in comparison to the V600-series Units. Functions are upwardly compatible, so V600-series Units can be easily replaced with V680-series Units.

Commands	<ul style="list-style-type: none"> • Read with Error Correction • Write with Error Correction • UID Read • Noise Measurement
Communications specifications	<ul style="list-style-type: none"> • FIFO trigger • FIFO repeat • Multi-access trigger • Multi-access repeat <p style="text-align: right;">* FIFO trigger, FIFO repeat, Multi-access trigger, and Multi-access repeat specification cannot be used for communicating with V680-D1KP□□ Tags.</p>
DM Area settings	<ul style="list-style-type: none"> • UID Addition Setting • Write Protection Disable Setting • Antenna Connection Setting (V680-H01) • Results Monitor Output Setting • Test Operation Setting • Run/Test Switching Method Setting
Test Operations (Set in the DM Area)	<ul style="list-style-type: none"> • Distance level measurement • Read/Write speed level measurement • Noise level measurement • Communications success rate measurement
CIO Area outputs	Run/Test Bit (Only when using the Run/Test Switching Method Setting is enabled in the DM Area.)
CIO Area inputs	<ul style="list-style-type: none"> • Antenna Error Flag (9C) • ID System Error 1 (79) • ID System Error 2 (7E) • ID System Error 3 (7F) • Error Correction Flag (77) • Results Output Monitor <p style="margin-left: 20px;">Run Mode: Communications time or noise level</p> <p style="margin-left: 20px;">Test Mode: Result contents of tests</p>
Others	<p>If a command error or data storage area error occurs in a V600-series ID Sensor Unit, the Error End Flag will not be turned ON. With a V680-series ID Sensor Unit, the Error End Flag will be turned ON for these errors.</p> <p>With a V600-series ID Sensor Unit, command errors and data storage errors are not monitored in the Processing Results Monitor, but a V680-series ID Sensor Unit will monitor them and use an error code of E014.</p>

Meanings of Symbols



Indicates particularly important points related to a function, including precautions and application advice.

CHECK!



Indicates page numbers containing relevant information.



Indicates reference to helpful information and explanations for difficult terminology.

Table of Contents

Introduction	1
READ AND UNDERSTAND THIS DOCUMENT	2
Safety Precautions	4
Regulations and Standards	6
Precautions for Safe Use	7
Precautions for Correct Use	8
Precautions for Users of V600-series ID Sensor Units	9
Meanings of Symbols	10
Table of Contents	11
Features and System Configuration	13
Outline of Features and Functions	14
Using Heat-resistive Tags (V680-D1KP58HTN and V680-D1KP58HT)	17
System Configuration	22
Functions by Application	28
CS-series ID Sensor Units	29
Specifications	30
Operating Procedure	32
Part Names and Functions	38
Connections and Wiring	41
CJ-series ID Sensor Units	45
Specifications	46
Operating Procedure	48
Part Names and Functions	54
Connections and Wiring	57
Data Exchange with the CPU Unit	61
Outline of Data Exchange	62
Initial Settings Data	66

I/O Data Allocations	68
----------------------	----

ID Sensor Unit Functions	77
---------------------------------	-----------

Operating Modes	78
Communications Specifications	85
Parameter Settings in DM Area	93
ID Tag Memory	99
Write Protection	101
ID Tag Service Life Check	108
ID Tag Memory Check	112
ID Tag Memory Error Correction	114

Controlling the ID Sensor Unit	117
---------------------------------------	------------

ID Sensor Unit Operation	118
Communications Commands	125
Communications Time	141

Troubleshooting Alarms and Errors	145
------------------------------------------	------------

Indicators and Error Check Flowcharts	146
ID Sensor Unit Alarms	148
CPU Unit Errors	151
Restarting Special I/O Units	152
Troubleshooting	153

Appendices	157
-------------------	------------

Dimensions	158
Sample Programming	160
Data Coding Tables	204
Degree of Protection	208

Revision History	210
-------------------------	------------

SECTION 1

Features and System Configuration

☒ Outline of Features and Functions	14
☒ Using Heat-resistive Tags (V680-D1KP58HTN and V680-D1KP58HT)	17
☒ System Configuration	22
☒ Functions by Application	28

Outline of Features and Functions

- SYSMAC CS-series ID Sensor Units

One-channel ID Sensor Unit
(CS1W-V680C11)

Two-channels ID Sensor Unit
(CS1W-V680C12)

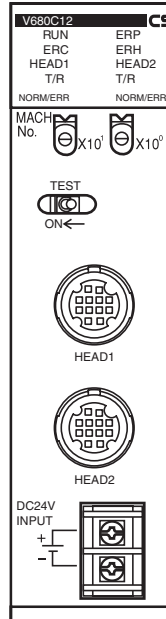
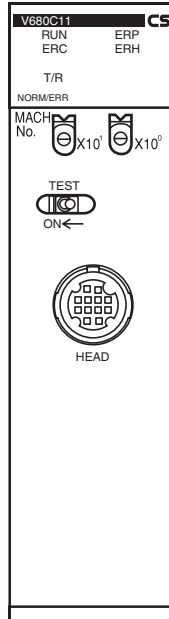

These ID Sensor Units are used in SYSMAC CS-series PLCs to read and write data for V680-series ID Tags. There are two models: a One-channel ID Sensor Unit (CS1W-V680C11) and a Two-channels ID Sensor Unit (CS1W-V680C12).

• SYSMAC CJ-series ID Sensor Units

One-channel ID Sensor Unit
(CJ1W-V680C11)

Two-channels ID Sensor Unit
(CJ1W-V680C12)

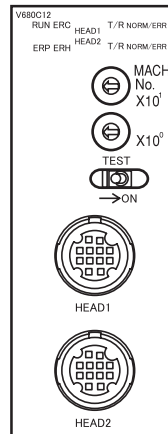
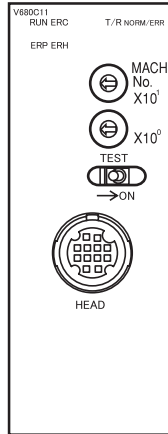

These ID Sensor Units are used in SYSMAC CJ-series PLCs to read and write data for V680-series ID Tags. There are two models: a One-channel ID Sensor Unit (CJ1W-V680C11) and a Two-channels ID Sensor Unit (CJ1W-V680C12).

	CS1W-V680C11	CS1W-V680C12	CJ1W-V680C11	CJ1W-V680C12
Amplifier/ Antennas	V680 Series (V680-HA63□/V680-H□□)			
Maximum number of connected Antennas	1	2	1	2
ID Tags	V680 Series (V680-D□□F□□ or V680-D□□P□□)			
Commands	Read Write Bit Set Bit Clear Mask Bit Write Calculation Write Data Fill Data Check Number of Writes Control Read with Error Correction Write with Error Correction UID Read Noise Measurement	Read Write Bit Set Bit Clear Mask Bit Write Calculation Write Data Fill Data Check Number of Writes Control Copy Read with Error Correction Write with Error Correction UID Read Noise Measurement	Read Write Bit Set Bit Clear Mask Bit Write Calculation Write Data Fill Data Check Number of Writes Control Read with Error Correction Write with Error Correction UID Read Noise Measurement	Read Write Bit Set Bit Clear Mask Bit Write Calculation Write Data Fill Data Check Number of Writes Control Copy Read with Error Correction Write with Error Correction UID Read Noise Measurement

- An RFID system consists of an ID Sensor Unit in a CS-series/CJ-series CPU Rack or CS-series/CJ-series Expansion Rack, one or two Antennas connected to the ID Sensor Unit, and ID Tags connected to moving bodies.
- The ID Sensor Unit operates through the Antennas to write data from the CS/CJ-series CPU Unit to the ID Tags and read data from the ID Tags to the CS/CJ-series CPU Unit.

■ Differences between Version 1.2 and Pre-Version 1.2

The following functions have been added to version 1.2 in comparison to pre-version 1.2. Functions are upwardly compatible, so pre-version 1.2 can be replaced with version 1.2.

■ CA1D Mode Setting Added for Tag Memory

If you are using a V680-CA1D/-CA2D ID Controller, always set the Tag memory setting to CA1D Mode. Setting the Tag memory setting to CA1D Mode enables reading and writing Heat-resistant Tags (V680-D1KP58HTN and V680-D1KP58HT) that were written by the V680-CA1D/-CA2D.

■ New Data Transfer Setting

In addition to cyclically transferring 160 bytes/scan, Intelligent I/O Instructions can now be used to transfer up to 2,048 bytes in one scan.

■ Parameters Added to Data Memory Allocation

DM Area allocations now include a Tag memory setting and data transfer setting.



CHECK!

Refer to *DM Area Allocations and Contents* on page 66 for details on the DM Area.



p. 66



CHECK!

A label on the side of the ID Sensor Unit shows the version for Units with version 1.2 or newer.

• CS1W-V680C1□



• CJ1W-V680C1□

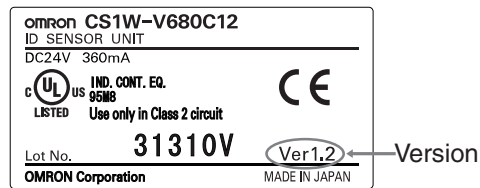

CHECK!

A different memory map may be used when reading or writing Heat-resistant Tags that were written by the V680-CA1D/-CA2D from a Reader/Writer that is manufactured by a company other than OMRON. Refer to *Operation When Tag Memory Setting Is Set to Standard Mode* in this section.



p. 20

Using Heat-resistive Tags (V680-D1KP58HTN and V680-D1KP58HT)

This section provides information for using Heat-resistive Tags (V680-D1KP58HTN or V680-D1KP58HT). If you are not using a Heat-resistive Tag, set the Tag memory setting to Standard Mode.

Precautions for Saving Data at High Temperatures

If you are using Heat-resistive Tags (V680-D1KP58HTN or V680-D1KP58HT), write the data again after saving data at a high temperature even if it is not necessary to change the data. A "high temperature" is one between 110°C and 200°C.

Using a Controller for a Heat-resistant RFID System (V680-CA1D/-CA2D)

If you are using Heat-resistive Tags (V680-D1KP58HTN or V680-D1KP58HT) and also using a V680-CA1D/-CA2D ID Controller, set the Tag memory setting of the ID Sensor Unit (version 1.2 or newer) to CA1D Mode.



CHECK!

A label on the side of the ID Sensor Unit shows the version for Units with version 1.2 or newer.

- CS1W-V680C1□

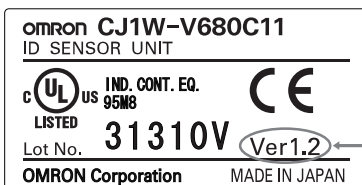

- CJ1W-V680C1□

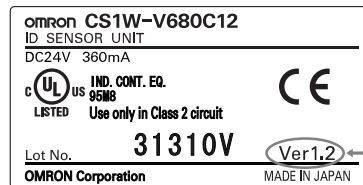

CHECK!

If you are not using the V680-CA1D/-CA2D, the Tag memory setting does not need to be changed. Refer to information in *System Configuration*.

Combining the V680-CA1D/-CA2D with Other V680-series Models

When using other models of Controller with the V680-CA1D/-CA2D, make sure that the version allows setting the Tag memory setting to CA1D Mode.



CHECK!

To use the CS/CJ1W-V680C1□, it must be version 1.2 or newer.

To use the V680-CD5D01-V2, it must be version 2.3 or newer.

To use the V680-CH□D, it must be version 1.1 or newer.



CHECK!

A label on the side of the ID Sensor Unit shows the version for Units with version 1.2 or newer.

- CS1W-V680C1□

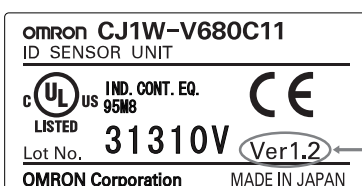

- CJ1W-V680C1□



Precautions when Setting the Tag Memory Setting to CA1D Mode

■ Applicable ID Tags

Only the V680-D1KP□□ ID Tags can be used when the Tag memory setting is set to CA1D Mode. V680-D□KF□□ ID Tags cannot be used.

■ ID Tags That Can Be Used

Model
V680-D1KP58HT
V680-D1KP58HTN
V680-D1KP52MT
V680-D1KP53M
V680-D1KP66T
V680-D1KP66MT

■ ID Tags That Cannot Be Used

Model
V680-D2KF52M
V680-D2KF67
V680-D2KF67M
V680-D8KF67
V680-D8KF67M
V680-D8KF68
V680-D32KF68

■ CA1D Mode Setting for Tag Memory and Write Protection

When setting the Tag memory setting to CA1D Mode, always disable write protection. Set word m+2 (Write Protection Setting) in the DM Area to 01 to disable write protection.



Refer to *DM Area Allocations and Contents* on page 66 for details on the DM Area.



■ Combining ID Sensor Units and ID Controllers

The address maps in the ID Tags for the V680-D1KP□□ (except for the V680-D1KP58HT) are reversed between the V680-CA1D/-CA2D ID Controller and CS/CJ1W-V680C1□ ID Sensor Units (with Tag memory setting set to CA1D Mode for version 1.2 or newer), and the V680-CA5D01-V2 (version 2.1 or older) ID Controller and CS/CJ1W-V680C1□ ID Sensor Units (with Tag memory setting set to Standard Mode for version 1.2 or newer). Therefore, when you use ID Tags with a V680-CA1D/-CA2D ID Controller, always set the Tag memory setting to CA1D Mode in any other models of ID Controller or ID Sensor Units that are used for the same ID Tags.

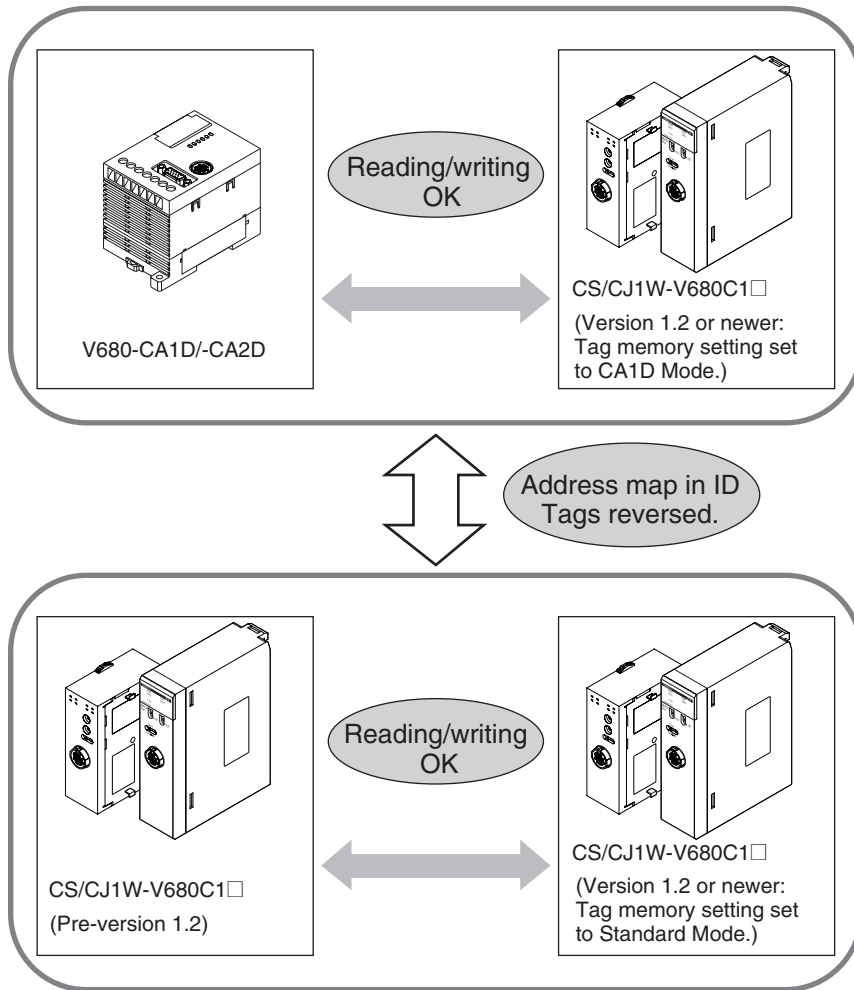

■ Operation When Tag Memory Setting Is Set to Standard Mode

When data that was written to a V680-D1KP58HTN ID Tag with the V680-CA1D/-CA2D ID Controller is read from a CS/CJ1W-V680C1□ ID Sensor Unit, the data is read from addresses that are reversed in one-block (eight-byte) units.

If you are going to use an ID Sensor Unit in the same line as a V680-CA1D/-CA2D ID Controller, use an ID Sensor Unit with version 1.2 or newer and set the Tag memory setting to CA1D Mode.

Address	Data written with V680-CA1D/-CA2D	Data read with CS/CJ1W-V680C1□ (pre-version 1.2) or CS/CJ1W-V680C1□ (version 1.2 or newer with Tag memory setting set to Standard Mode)
0000 hex	01 hex	00 hex
0001 hex	23 hex	00 hex
0002 hex	45 hex	00 hex
0003 hex	67 hex	00 hex
0004 hex	89 hex	00 hex
0005 hex	AB hex	00 hex
0006 hex	CD hex	00 hex
0007 hex	EF hex	00 hex
:	:	:
:	:	:
03E0 hex	00 hex	01 hex
03E1 hex	00 hex	23 hex
03E2 hex	00 hex	45 hex
03E3 hex	00 hex	67 hex
03E4 hex	00 hex	89 hex
03E5 hex	00 hex	AB hex
03E6 hex	00 hex	CD hex
03E7 hex	00 hex	EF hex

■ Operation When Tag Memory Setting Is Set to CA1D Mode

If the Tag memory setting for the CS/CJ1W-V680C1□ (version 1.2 or newer) is set to CA1D Mode, data is read from or written to addresses that are reversed in block units for the V680-D1KP□□ (except for the V680-D1KP58HT) in the same way as for the V680-CA1D/-CA2D. Therefore, data can be read from the same addresses as those to which data was written by the V680-CA1D/-CA2D.

Address	Data written with V680-CA1D/-CA2D	Data read with CS/CJ1W-V680C1□ (version 1.2 or newer with Tag memory setting set to CA1D Mode)
0000 hex	01 hex	01 hex
0001 hex	23 hex	23 hex
0002 hex	45 hex	45 hex
0003 hex	67 hex	67 hex
0004 hex	89 hex	89 hex
0005 hex	AB hex	AB hex
0006 hex	CD hex	CD hex
0007 hex	EF hex	EF hex
:	:	:
:	:	:
03E0 hex	00 hex	00 hex
03E1 hex	00 hex	00 hex
03E2 hex	00 hex	00 hex
03E3 hex	00 hex	00 hex
03E4 hex	00 hex	00 hex
03E5 hex	00 hex	00 hex
03E6 hex	00 hex	00 hex
03E7 hex	00 hex	00 hex

Same as data read with V680-CA1D/-CA2D.

System Configuration

Basic System Configuration

CS-series PLCs

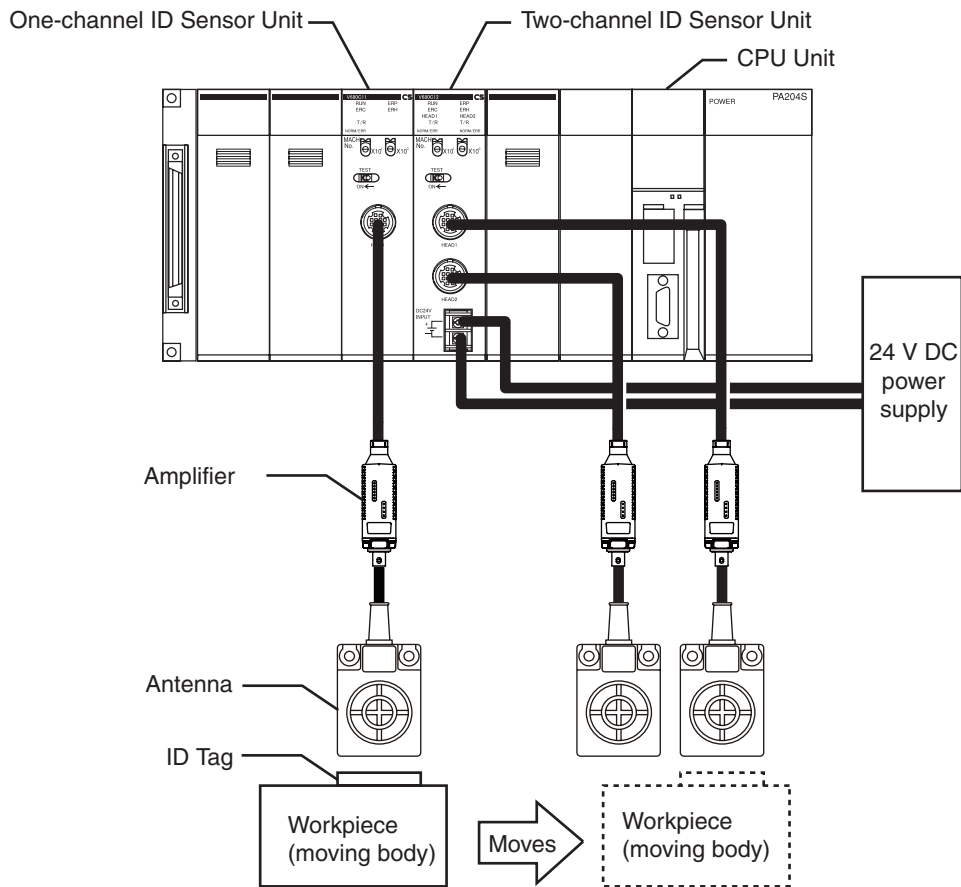

Note: The above example uses one One-channel ID Sensor Unit (CS1W-V680C11) and one Two-channels ID Sensor Unit (CS1W-V680C12).



The V680-H01 Antenna can be connected to only the One-channel ID Sensor Unit (CS1W-V680C11). It cannot be connected to the Two-channels ID Sensor Unit (CS1W-V680C12).

CHECK!



For details on Antennas, Amplifiers, and ID Tags, refer to the following manuals:
RFID System V680 Series User's Manual for Amplifiers, Antennas, and ID Tags (FRAM) (Cat. No. Z248),
V680 Series RFID System Amplifier/Tags (EEPROM) User's Manual (Cat. No. Z262), and
Heat-resistive RFID System V680 Series User's Manual (Cat. No. Z221).

CHECK!

■ CJ-series PLCs

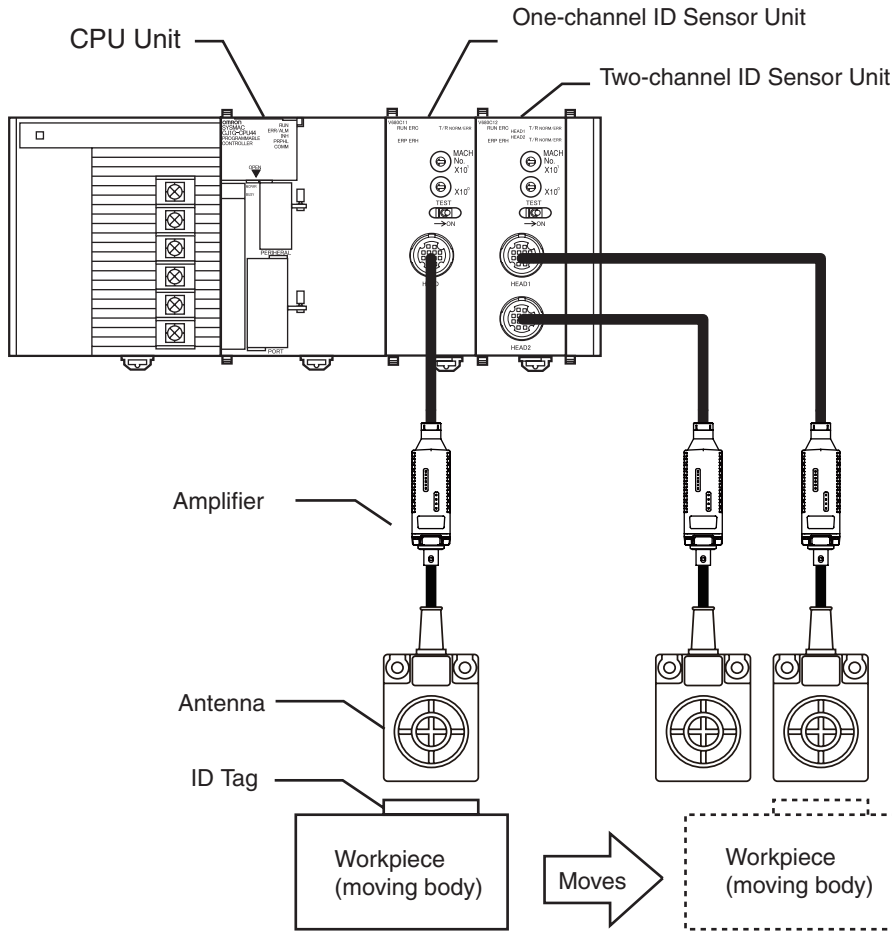

Note: The above example uses one One-channel ID Sensor Unit (CJ1W-V680C11) and one Two-channels ID Sensor Unit (CJ1W-V680C12).



The V680-H01 Antenna can be connected to only the One-channel ID Sensor Unit (CJ1W-V680C11). It cannot be connected to the Two-channels ID Sensor Unit (CJ1W-V680C12).



For details on Antennas, Amplifiers, and ID Tags, refer to the following manuals:
RFID System V680 Series User's Manual for Amplifiers, Antennas, and ID Tags (FRAM) (Cat. No. Z248),
V680 Series RFID System Amplifier/Tags (EEPROM) User's Manual (Cat. No. Z262), and
Heat-resistive RFID System V680 Series User's Manual (Cat. No. Z221).

Mounting Restrictions

■ CS-series PLCs

CS-series ID Sensor Units are classified as CS-series Special I/O Units.

- These Units can be mounted to a CS-series CPU Rack or CS-series Expansion Rack.
- The number of Units per CPU Rack or Expansion Rack depends on the maximum supply current of the Power Supply Unit and current consumption of other Units on the Rack.

The following table lists the maximum number of Units per Rack when only ID Sensor Units are mounted.

Power Supply Unit	CS1W-V680C11		CS1W-V680C12
	V680-HA63 <input type="checkbox"/> Amplifier connected	V680-H01 Antenna connected	V680-HA63 <input type="checkbox"/> Amplifier connected
C200HW-PA204 C200HW-PA204S C200HW-PA204R C200HW-PD204	5	2	10
C200HW-PA209R	9	4	10



CHECK!

The V680-H01 Antenna can be connected to only the One-channel ID Sensor Unit (CS1W-V680C11). It cannot be connected to the Two-channels ID Sensor Unit (CS1W-V680C12).

■ CJ-series PLCs

CJ-series ID Sensor Units are classified as CJ-series Special I/O Units.

- These Units can be mounted to a CJ-series CPU Rack or CJ-series Expansion Rack.
- The number of Units per CPU Rack or Expansion Rack depends on the maximum supply current of the Power Supply Unit and current consumption of other Units on the Rack.

The following table lists the maximum number of Units per Rack when only ID Sensor Units are mounted.

Power Supply Unit	CJ1W-V680C11		CJ1W-V680C12
	V680-HA63 <input type="checkbox"/> Amplifier connected	V680-H01 Antenna connected	V680-HA63 <input type="checkbox"/> Amplifier connected
CJ1W-PA205R	4	2	2
CJ1W-PA202	2	1	1



CHECK!

The V680-H01 Antenna can be connected to only the One-channel ID Sensor Unit (CJ1W-V680C11). It cannot be connected to the Two-channels ID Sensor Unit (CJ1W-V680C12).



CHECK!

The I/O words allocated to Special I/O Units are determined by the setting of the unit number switches on the front of the Unit. They are not affected by the slots (positions) in which the Units are mounted.

Mounting Units

■ CS-series PLCs

Use the following procedure to mount an ID Sensor Unit to the Backplane.

1. Lock the top of the ID Sensor Unit into the slot on the Backplane.

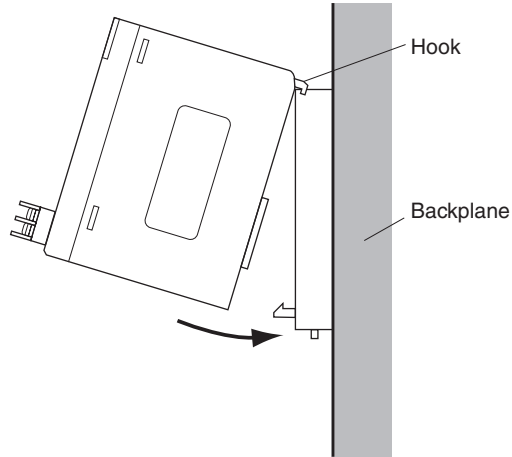

2. Rotate the Unit downwards as shown in the following diagram. While making sure to align the Unit connector properly with the connectors on the Backplane, and then tighten the mounting screws securely to a tightening torque of 0.4 N·m
3. To remove the Unit, first loosen the mounting screws using a Phillips screwdriver.

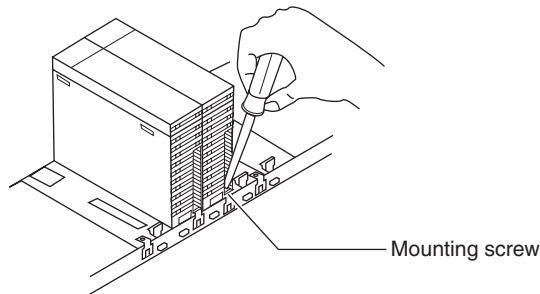

Leave enough space below each Rack, as shown in the following diagram, for mounting and removing the Units.

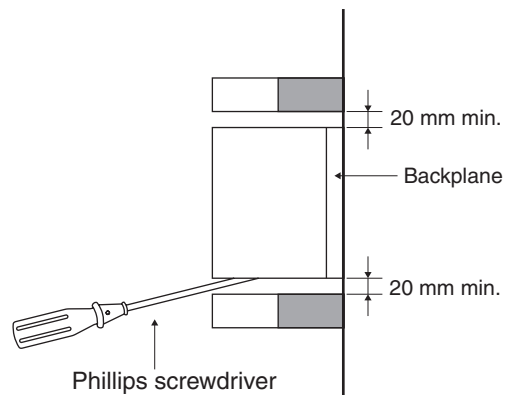

■ CJ-series PLCs

ID Sensor Units are connected as I/O Units in the system configuration, as shown below.

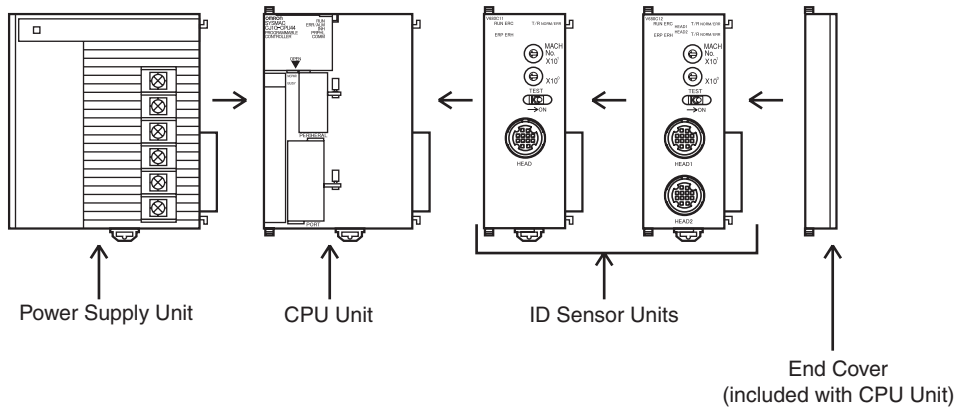

Use the following procedure to connect an ID Sensor Unit.

1. Align the connectors and press in firmly on the Units to connect them completely.

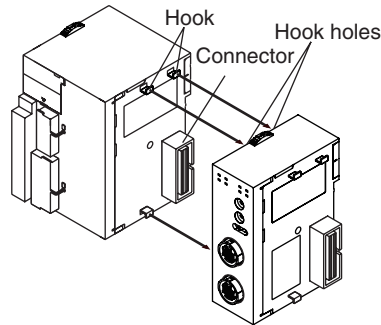

2. Move the yellow sliders on the top and bottom of the Unit to the lock position to secure the Units. The sliders should click into place.

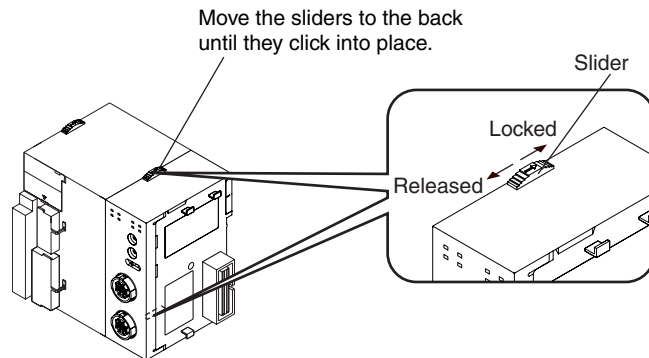

3. Attach an End Cover to the Unit on the right end of the Rack.



The CJ-series PLC may not operate properly if the sliders are not locked firmly into place.

Unit Handling Precautions

- Be sure to turn OFF the power supply to the PLC before installing or disconnecting Units, or connecting lines.
- To reduce the influence of electrical noise, wire input and output lines in separate ducts from high-voltage and power lines.
- When wiring a Unit, leave the label in place on the top of the Unit to prevent wire clippings or other materials from getting inside the Unit. When wiring has been completed, remove the label to ensure proper heat dissipation.

■ CS-series PLCs

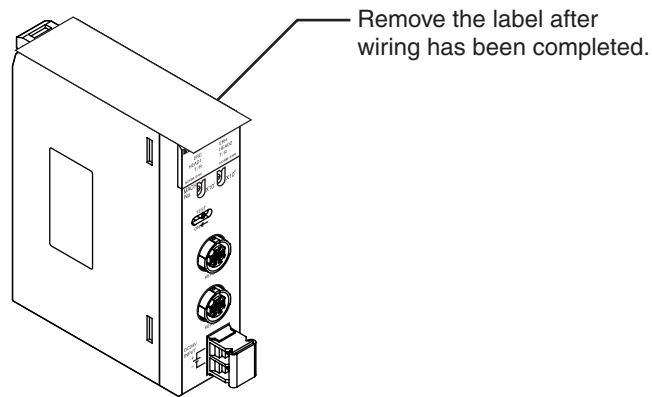

■ CJ-series PLCs

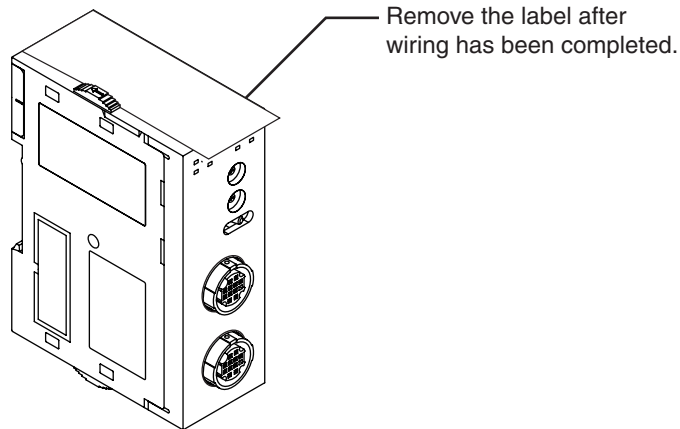

Functions by Application

Application	Function	Reference
Performing communications tests with ID Tags without programming the CPU Unit	Test Mode	p. 78
Adjusting communications timing with ID Tags Examples: <ul style="list-style-type: none">• Communicating with ID Tags stopped in front of the Antenna• Communicating with ID Tags passing by the Antenna	Communications Specifications	p. 85
Protecting ID Tag memory from being overwritten by incorrect data	Write Protection	p. 101
Managing ID Tag life	ID Tag Service Life Check	p. 108
Checking the suitability of ID Tag memory	ID Tag Memory Check	p. 112
Checking ID Tag memory and correcting one-bit errors.	ID Tag Memory Error Correction	p. 114

SECTION 2

CS-series ID Sensor Units

☒ Specifications	30
☒ Operating Procedure	32
☒ Part Names and Functions	38
☒ Connections and Wiring	41

Specifications

General Specifications

General specifications conform to those of SYSMAC CS-series Special I/O Units.

Performance Specifications

	CS1W-V680C11		CS1W-V680C12	
Unit classification	Special I/O Unit			
Influence on CPU Unit's cycle time	0.15 ms		0.3 ms	
External power supply	---		24 VDC +10%/-15%, 360 mA	
Internal current consumption	V680-HA63□ Amplifier connected: 5 VDC, 260 mA 24 VDC, 125 mA V680-H01 Antenna connected: 5 VDC, 260 mA 24 VDC, 280 mA		5 VDC, 320 mA 24 VDC, 0 mA	
Dimensions	35 x 130 x 101 mm (W x H x D)			
Weight	180 g max.		300 g max.	
Mounting location	CS-series CPU Rack or CS-series Expansion Rack (Cannot be mounted to C200H Expansion I/O Racks or SYSMAC BUS Slave Racks.)			
No. of Units per Rack	V680-HA63□ Amplifier connected: 5 per Rack V680-H01 Antenna connected: 2 per Rack (See note 1.)		10 per Rack (See note. 1)	
Connectable Antennas (See note 2.)	V680-series Amplifiers (V680-HA63□) V680-series Antennas (V680-H□□) One channel		V680-series Amplifiers (V680-HA63□) V680-series Antennas (V680-H□□) One or two channels	
Applicable ID Tags	V680-series ID Tags (V680-D□□)			
No. of allocated unit numbers	1		2	
No. of allocated words	10 words		20 words	
Control protocol	Special protocol			
Data exchange methods with CPU Unit	Special I/O Unit Area in CIO Area: CIO 2000 to CIO 2959	Constant data exchange of 10 words/Unit	CPU Unit to ID Sensor Unit	Unit controls, communications processing specification, data storage area specification
			ID Sensor Unit to CPU Unit	Unit information, results information, processing results monitor
	Special I/O Unit words in DM Area: D20000 to D29599	100 words/Unit transferred when power is turned ON or when restarting the Unit	CPU Unit to ID Sensor Unit	System Settings, Auto Wait Time Setting, Write Protection Disable Setting, Antenna Connection Setting, Results Monitor Output, Test Setting, Run/Test Switching Method Setting
Data transfer quantity	2,048 bytes max. (160 bytes/scan) (See note 3.)		2,048 bytes max./channel (160 bytes/scan) (See note 3.)	
Operating modes	Run Mode			
	Test Mode	<ul style="list-style-type: none"> • Communications tests • Distance level measurements • Read speed level measurements • Write speed level measurements • Noise level measurements • Communications success rate measurements 		
Diagnostic function	(1) CPU watchdog timer (2) Communications error detection with ID Tag (3) Antenna power supply error			

- Note 1.** "Rack" indicates either the CPU Rack or an Expansion Rack.
- 2.** The V680-H01 Antenna can be connected only to the CS1W-V680C11 ID Sensor Unit. It cannot be used with the CS1W-V680C12 ID Sensor Unit.
- 3.** If using Intelligent I/O Instructions is specified as the data transfer method, up to 2,048 bytes can be transferred in one scan.

Communications Specifications

	CS1W-V680C11	CS1W-V680C12
Communications controls	(1) Tag Communications Speed (Normal Mode or High-speed Mode) (2) Write Verification (3) Auto Wait Time Setting (4) UID Addition Setting (5) Write Protection Disable Setting (6) Antenna Connection Setting (One-channel ID Sensor Unit (CS1W-V680C11)) (7) Results Monitor Output Setting	
Commands	Read Write Bit Set/Bit Clear Mask Bit Write Calculation Write Data Fill Data Check Number of Writes Control Read with Error Correction Write with Error Correction UID Read Noise Measurement	Read Write Bit Set/Bit Clear Mask Bit Write Calculation Write Data Fill Data Check Number of Writes Control Copy Read with Error Correction Write with Error Correction UID Read Noise Measurement
Communications specification	Single trigger Single auto Repeat auto FIFO trigger (See note) FIFO repeat (See note) Multi-access trigger (See note) Multi-access repeat (See note)	

Note: FIFO trigger, FIFO repeat, Multi-access trigger, and Multi-access repeat specification cannot be used for communicating with V680-D1KP□□ Tags.

Operating Procedure

The operating procedure for an ID Sensor Unit is shown in the following flowchart.

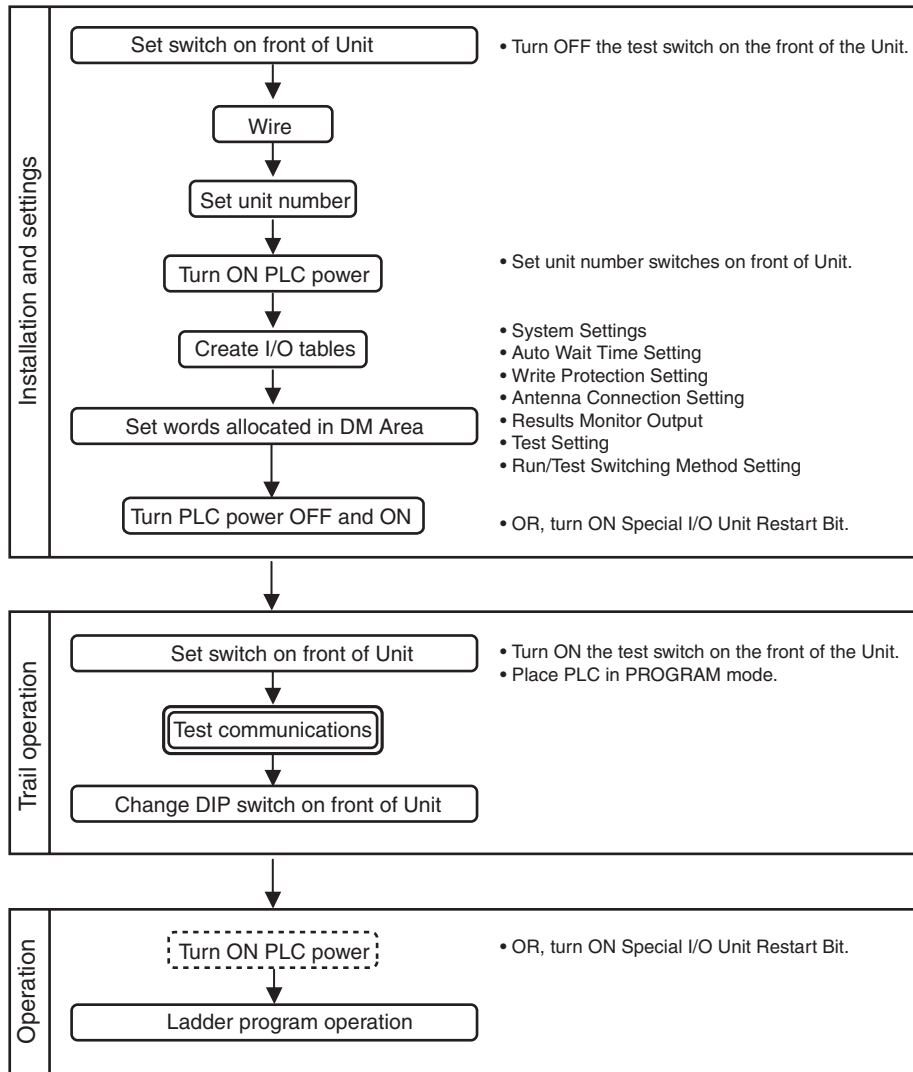

- When using CX-Programmer V3.0 or later with the CS1W-V680C12, “I” will be displayed before addresses for inputs in the ladder diagram and “Q” will be displayed before addresses for outputs for operation data. In the CX-Programmer’s I/O Table Window, select SIOU/C200H ASCII Unit (A) and then, from the Enter SIOU Details Window, set the Address per Unit to 2, the Input Words to 3, and the Output Words to 7, and select the Repeat IN/OUT for each Address per Unit option.
- When using CX-Programmer V2.0 or later with the CS1W-V680C11, “I” will be displayed in the ladder diagram before address for inputs and “Q” will be displayed before addresses for outputs for operation data.
- When using the CS1W-V680C12, turn ON the power supply for external inputs at the same time or after the CPU Unit power supply is turned ON.

Operating Procedure Example

The following is an operating procedure example for the following conditions.
Reading 10 Bytes of Data from ID Tag Address 0010 (Hex) Using a Trigger

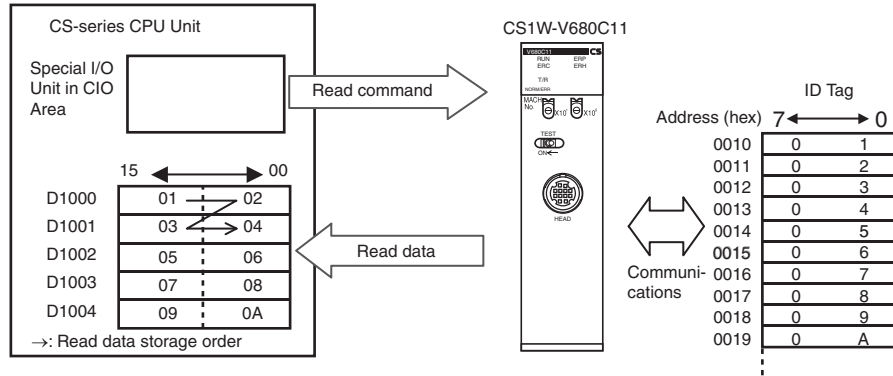

• Special I/O Unit in CIO Area Settings

Unit number: 00

Command: Read

Communications specification: Trigger

Read data storage order: Leftmost → Rightmost

First ID Tag read address: 0010 hex

Number of ID Tag read bytes: 10 bytes

Read data storage destination: D1000 to D1004

■ ID Sensor Unit Settings

1. Test switch (Set on Unit's front panel.)

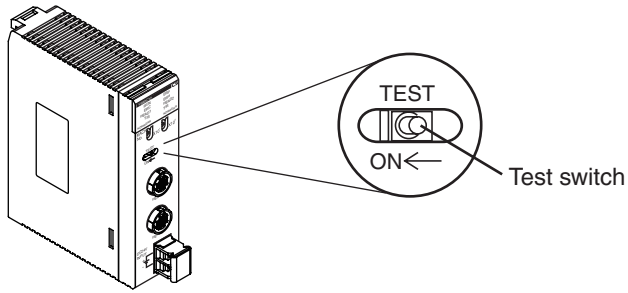

2. Mounting and Installation

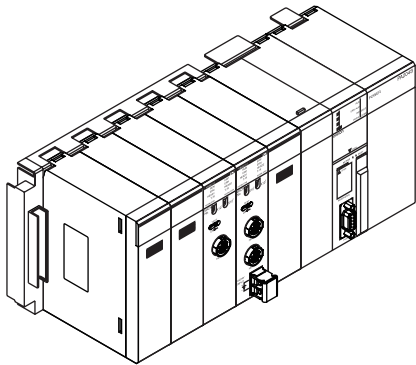

3. Unit Number Setting

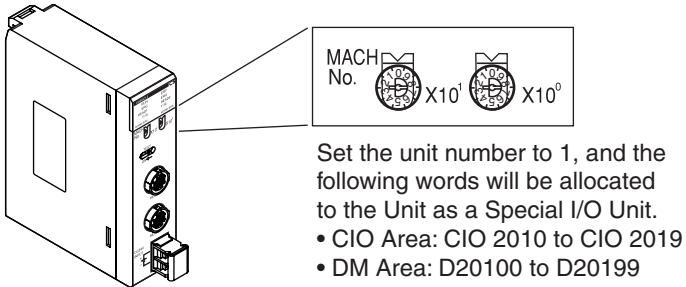

4. PLC Power Supply ON

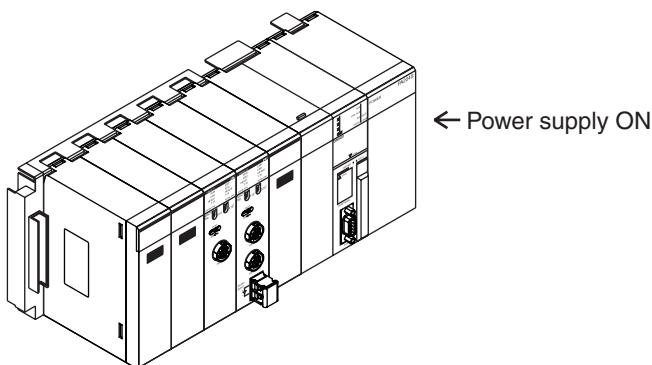

- When using the CS1W-V680C12, turn ON the external input power supply at the same time or after the CPU Unit power supply is turned ON.

■ Creating I/O Tables

Always create the I/O tables after turning ON the PLC power supply.
The I/O tables can be created from a CS/CJ-series Programming Console or a CX-Programmer (Support Software used to control a PLC, e.g., to create programs or change operating modes).

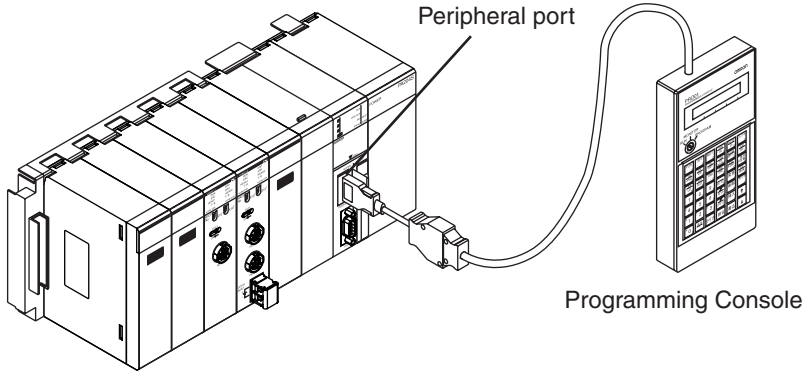

■ Initial Settings

1. Make the settings in the words allocated to Special I/O Units in the DM Area.



For information on setting the Special I/O Unit words in the DM Area, refer to *Parameter Settings in DM Area* on page 93.

CHECK!  p. 93

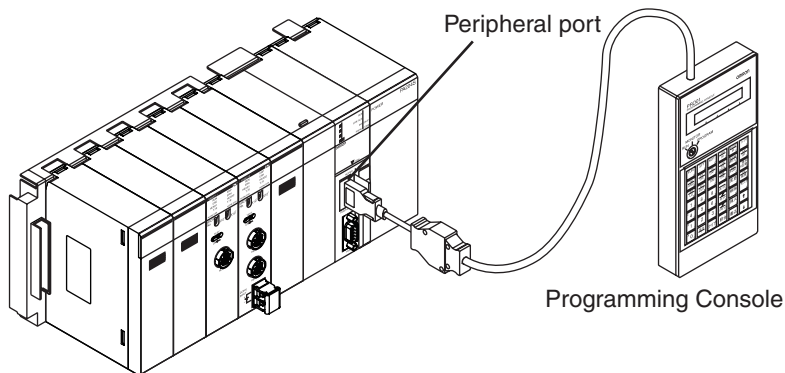

First word allocated to Unit in DM Area: $m = D20000 + (100 \times 0) = D20000$

DM address	Contents	Meaning															
		15	14	13	12	11	10	9	8	7	6	5	4	3	2	1	0
D20000	0 0 0 0	UID Addition 0: Disabled 1: Enabled				Test Mode Disable 0: Enabled 1: Disabled				Write Verification 0: Verification 1: No verification				Communications Speed 0: Normal 1: High-speed			
D20001	0 0 0 0	Auto Wait Time Setting range: 0000 to 9999 (×0.1 s) Factory setting: 0000 (infinite)															
D20002	0 0 0 0	Not used				Not used				Write Protection Disable 00: V680 method 01: Disabled 00: V600 method							
D20003	0 0 0 0	Not used				Not used				Not used				Antenna Connection 0: Standard Antenna 1: V680-H01			
D20004	0 0 0 0	Not used				Not used				Not used				Results Monitor Output 0: Communications time 1: Noise level			
D20005 to D20049	0 0 0 0	Not used															
D20050	0 0 0 0	Test Operation 00: Communications test A0: Distance level B0: Read speed level B1: Write speed level C0: Noise level C1: Communications success rate C2: Retry counts								Test Antenna 01: Antenna 1 02: Antenna 2							
D20051	0 0 0 0	Number of Test Bytes Setting range: 0000 to 0800 (byte)															
D20052 to D20079	0 0 0 0	Not used															
D20080	0 0 0 0	Not used								Run/Test Switching Method 1: CPU Unit 0: Test switch							
D20081	0 0 0 0	Not used								Tag Memory Setting 1: CA1D Mode 0: Standard Mode							
D20082 to D20089	0 0 0 0	Not used															
D20090	0 0 0 0	Not used								Data Transfer Setting 1: Use Intelligent I/O Instructions 0: Use cyclic transfer							
D20091 to D20099	0 0 0 0	Not used															

2. PLC Power Supply OFF and ON

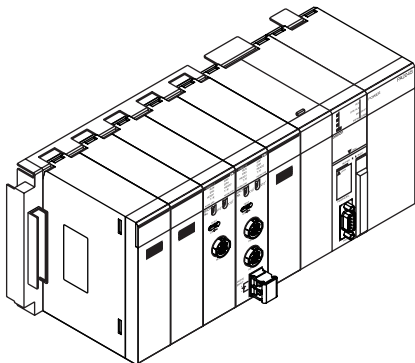

Power supply OFF → ON
(or turn ON the Unit Restart Bit)

■ Ladder Programming

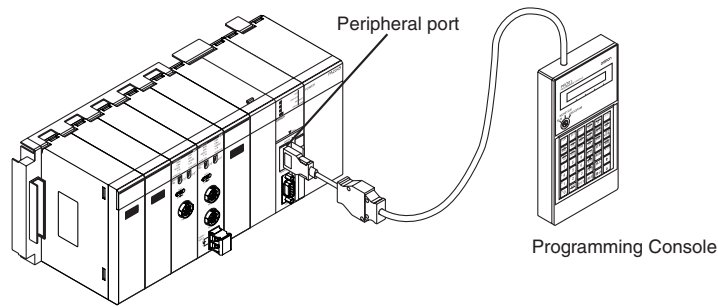

Set the Command, Communications Specification, Read Data Storage Order, First ID Tag Read Address, Number of Bytes to Read, and Read Data Storage Destination in CIO n+1 to CIO n+6 allocated in the Special I/O Unit Area (here, CIO 2011 to CIO 2016).

First word allocated to Unit in CIO Area: CIO 2000 + 10 × 0 = CIO 2000

Word address	Contents			Meaning														
				15	14	13	12	11	10	9	8	7	6	5	4	3	2	1
CIO 2001	00	0	0	Command						Communications specification			Data order					
CIO 2002	00	10		First read address														
CIO 2003	00	0A		Number of read bytes														
CIO 2004	10	00		Read data storage location (rightmost 4 digits)														
CIO 2005	0	0	00	Data storage area			Bank specification*			Read data storage location (leftmost 2 digits)								
CIO 2006	00	00		---														

*: Always 0 when DM Area is specified.

---: Ignored.

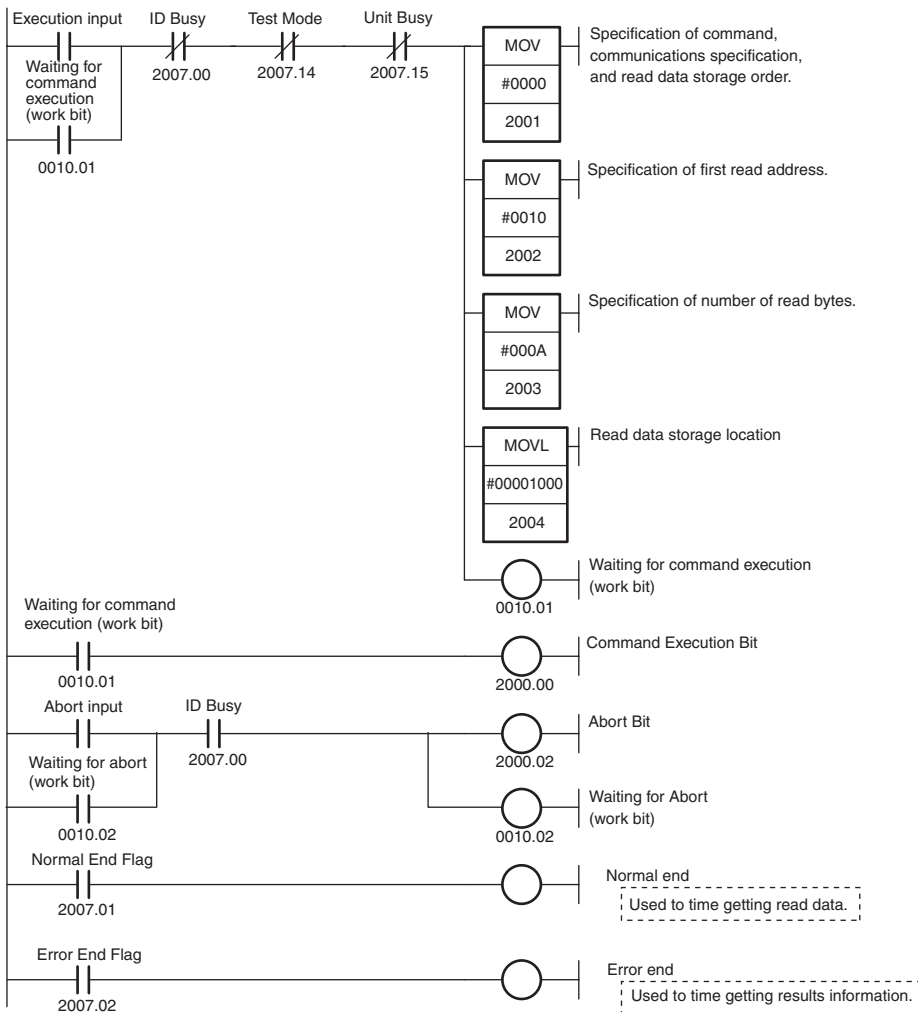

Part Names and Functions

Part Names

CS1W-V680C11
(front)

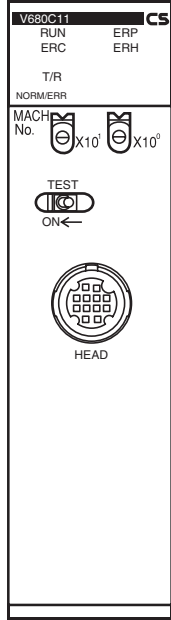

CS1W-V680C12
(front)

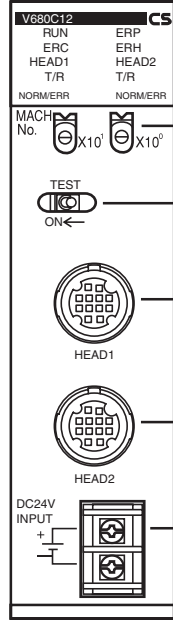

Status indicators

Unit number switches

Test switch

Connector for Amplifier/Antenna 1

Connector for Amplifier/Antenna 2

Antenna power supply terminals

(Back)

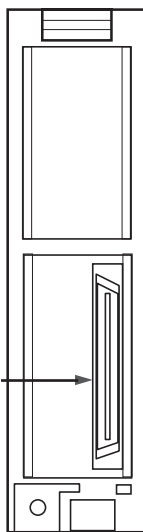

Backplane connector

Terminal block

(Side)

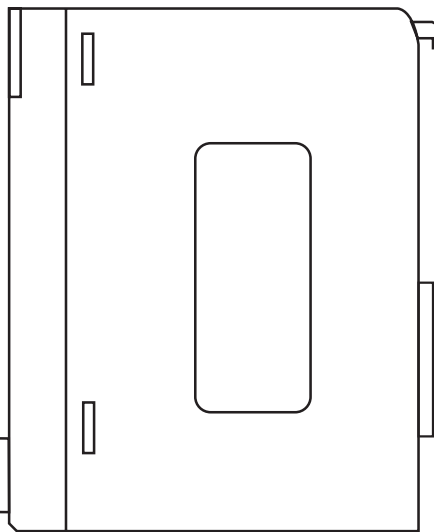

Indicators

Indicators show the operating status of the Units.

The relationship between the indicator status and the Units status is shown in the following table.

Indicator		Name	Color	Meaning	
RUN		RUN	Green	○ Lit	The ID Sensor Unit is operating normally.
				● Not lit	The ID Sensor Unit is stopped.
ERC (Error in Controller)		Unit error	Red	○ Lit	An error has occurred in the ID Sensor Unit.
				● Not lit	No error has occurred in the ID Sensor Unit.
ERH (Error at CPU Unit)		CPU Unit error	Red	○ Lit	An error has occurred in the CPU Unit.
				● Not lit	No error has occurred in the CPU Unit.
ERP (Antenna Power Error)		Antenna power error	Red	○ Lit	An error has occurred in the power supply to the Antenna.
				● Not lit	The power supply to the Antenna is normal.
HEAD1 (Antenna 1)	T/R	Communicating	Yellow	○ Lit	Communications are active.
				● Not lit	Communications not being performed with the ID Tag.
	NORM/ERR	Normal end	Green	○ Lit	Communications with the ID Tag ended normally.
				● Not lit	The indicator is not lit in all other cases.
		Error end	Red	○ Lit	Communications with the ID Tag ended in an error.
				● Not lit	The indicator is not lit in all other cases.
HEAD2 (Antenna 2)	T/R	Communicating	Yellow	○ Lit	Communications are active.
				● Not lit	Communications not being performed with the ID Tag.
	NORM/ERR	Normal end	Green	○ Lit	Communications with the ID Tag ended normally.
				● Not lit	The indicator is not lit in all other cases.
		Error end	Red	○ Lit	Communications with the ID Tag ended in an error.
				● Not lit	The indicator is not lit in all other cases.

Unit Number Switches

Data exchange between the CPU Unit and ID Sensor Unit is performed using words allocated to the Unit in the Special I/O Unit Area and in Special I/O Unit words the DM Area. The words allocated to the ID Sensor Unit in these two areas are determined by the setting of the unit number switches on the Unit's front panel.



Switch No.	Unit No.	CS1W-V680C11		CS1W-V680C12	
		Words allocated in Special I/O Unit Area	Words allocated in DM Area	Words allocated in Special I/O Unit Area	Words allocated in DM Area
0	Unit 0	CIO 2000 to CIO 2009	D20000 to D20099	CIO 2000 to CIO 2019	D20000 to D20199
1	Unit 1	CIO 2010 to CIO 2019	D20100 to D20199	CIO 2010 to CIO 2029	D20100 to D20299
:	:	:	:	:	:
94	Unit 94	CIO 2940 to CIO 2949	D29400 to D29499	CIO 2940 to CIO 2959	D29400 to D29599
95	Unit 95	CIO 2950 to CIO 2959	D29500 to D29599	(Cannot be set)	

Test Switch

The test switch on the Unit's front panel is used to switch between RUN Mode and Test Mode. Specify using the test switch in the Run/Test Switching Method Setting in the DM Area to enable using this switch.

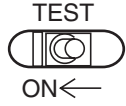

Status	Description
OFF	RUN mode (factory setting)
ON	Test Mode

Connections and Wiring

Connecting the Amplifier or Antenna

■ Connection Method

1. Holding the base of the connector, align the white mark on the Unit with the white mark on the connector and insert the connector.
2. Press in on the connector until it locks in place.

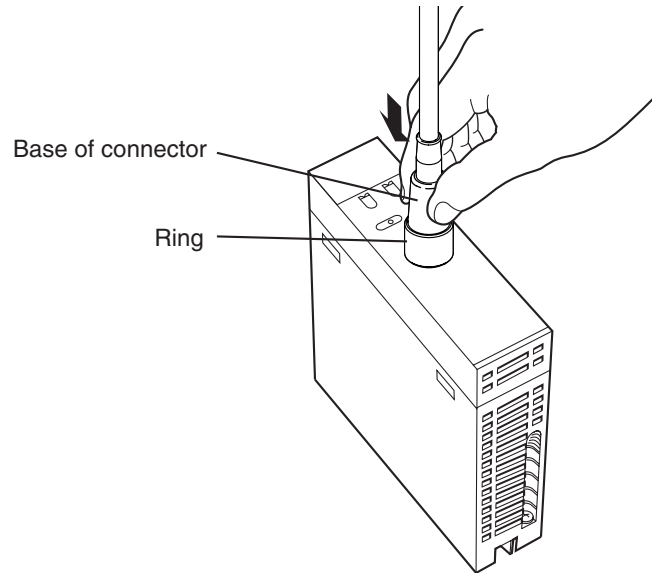

CHECK!

- The connector will not lock into place if you hold onto the ring. Always hold onto the base of the connector.



CHECK!

- The antenna that can be connected with the connector for Amplifier/Antenna is only V680-H01.

■ Removal Method

1. Hold onto the ring and pull straight out.

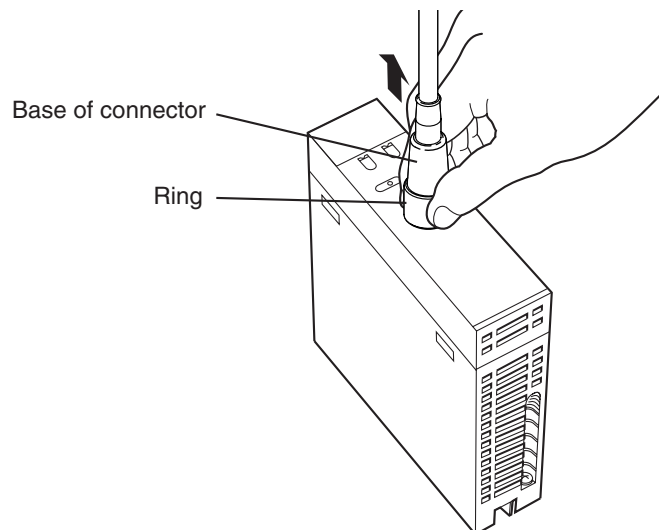

CHECK!

- The connector cannot be removed if you hold onto the base of the connector. Never pull on the cable with excessive force. The connectors may be broken or damaged.



CHECK!

- Connecting or disconnecting the connector with power to the Unit turned ON may cause the Unit to be damaged or malfunction.

Wiring the External Power Supply (CS1W-V680C12 Only)

Wire the power supply as shown below.

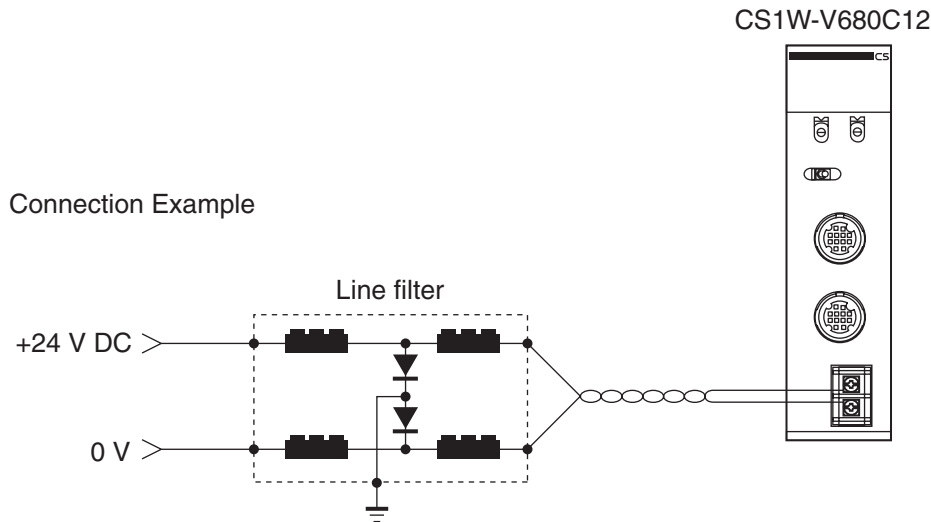

M3 self-lifting screws are used as the connection terminals for the power supply. When necessary, use the following crimp terminals. The tightening torque is approximately 0.58 N·m.

Examples of Applicable Crimp Connectors

Manufacturer	Model number	Applicable wire size	Shape
J.S.T Mfg. Co., Ltd.	1.25-N3A	AWG26 to 18	Forked
J.S.T Mfg. Co., Ltd.	1.25-Y3A		

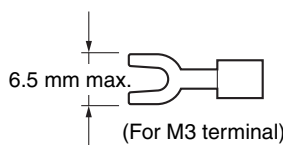

Recommended DC Power Supplies (Compact, DIN Track-mountable, manufactured by OMRON)

Model number	Output capacity	Input voltage
S8VS-03024	24 VDC, 1.3 A	100 to 240 VAC



- Although adequate measures have been taken inside the ID Sensor Unit for noise entering on the power supply line, supplying power through a line filter can be used to greatly attenuate ground noise.



- Although the rated power consumption of the CS1W-V680C12 is 360 mA at 24 VDC, be sure to consider the surge current when determining capacities.



- When using the CS1W-V680C12, turn ON the power supply for external inputs at the same time or after the CPU Unit power supply is turned ON.

Wiring for Safety and Noise Immunity

Antenna Cable and I/O Signal Lines

Wire the Antenna cable and I/O signal lines in separate ducts from power circuit cables both inside and outside the control panel.

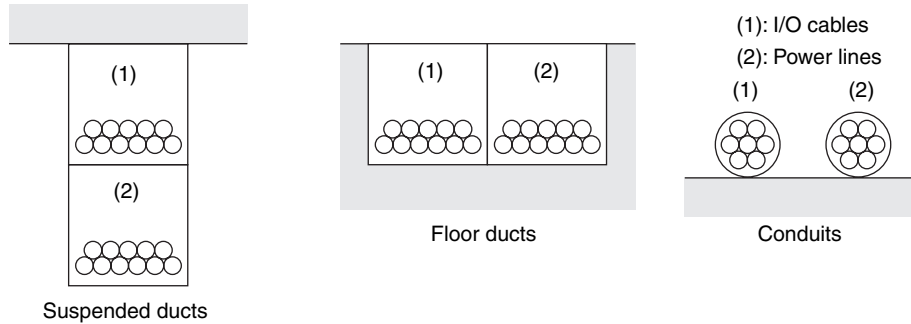

If the same ducts must be used, shielded cables can be used to increase resistance to noise. If a shielded cable is used, connect one end of the shield to ground.

Countermeasures for Inductive Loads

If I/O is connected to an inductive load, connect a surge killer or diode in parallel with the load.

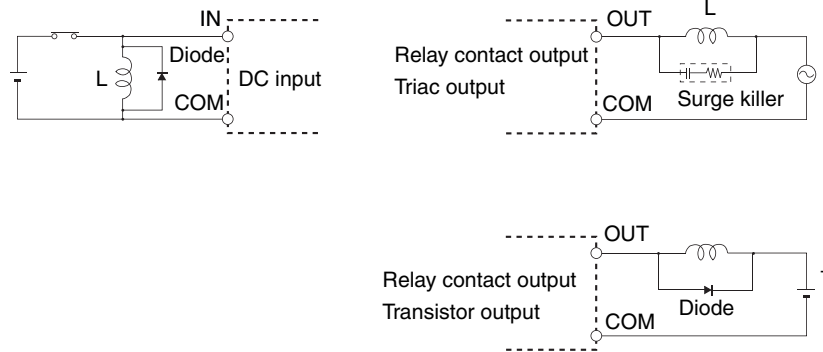

- Use surge killers and diodes that meet the following conditions:

Surge killer 

Resistance: 50 Ω

Capacitance: 0.47 μF

Voltage: 200 V

Diode 

Inrush withstand voltage: 3 times load voltage min.

Average rectified current: 1 A

• **Noise Countermeasures for External Wiring**

Consider the following items when wiring external lines, such as Antenna cable, I/O lines, power supply lines, and high-power lines.

- When using multiconductor cables for signal lines, do not use the same cable for both I/O lines and other control lines.
- When Racks are installed in parallel with each other, keep them separated by at least 300 mm.

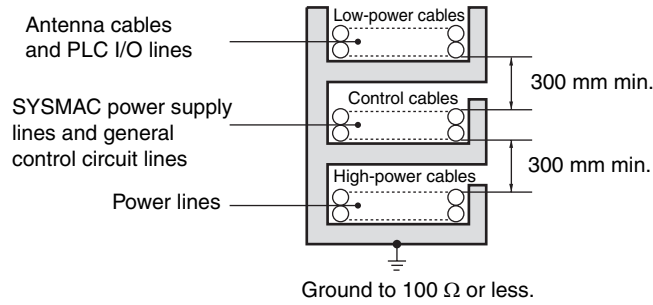

- When placing cables in the same duct, separate them with grounded iron plates.

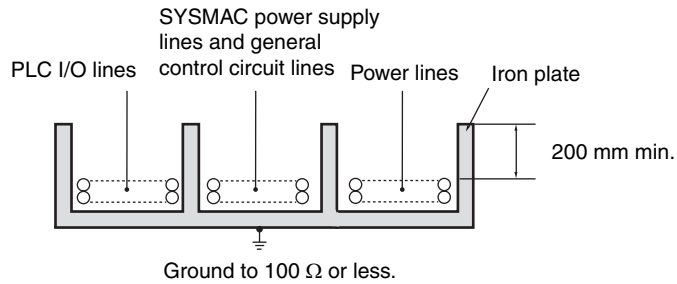

SECTION 3

CJ-series ID Sensor Units

☒ Specifications	46
☒ Operating Procedure	48
☒ Part Names and Functions	54
☒ Connections and Wiring	57

Specifications

General Specifications

General specifications conform to those of SYSMAC CJ-series Special I/O Units.

Performance Specifications

	CJ1W-V680C11	CJ1W-V680C12	
Unit classification	Special I/O Unit		
Influence on CPU Unit's cycle time	0.15 ms	0.3 ms	
Internal current consumption	V680-HA63□ Amplifier connected: 5 VDC, 260 mA 24 VDC, 130 mA V680-H01 Antenna connected: 5 VDC, 260 mA 24 VDC, 280 mA	5 VDC, 320 mA max. 24 VDC, 260 mA max.	
Dimensions	31 x 90 x 65 mm (W x H x D)		
Weight	120 g max.	130 g max.	
Mounting location	CJ-series Rack or CJ-series Expansion Rack (Cannot be mounted to C200H Expansion I/O Racks or SYSMAC BUS Slave Racks.)		
No. of Units per Rack	CJ1W-PA205R: V680-HA63□ Amplifier connected: 4 per Rack V680-H01 Antenna connected: 2 per Rack CJ1W-PA202: V680-HA63□ Amplifier connected: 2 per Rack V680-H01 Antenna connected: 1 per Rack (See note 1.)	CJ1W-PA205R: 2 CJ1W-PA202: 1 (See note 1.)	
Connectable Antennas (See note 2.)	V680-series Amplifiers (V680-HA63□) V680-series Antennas (V680-H□□) One channel	V680-series Amplifiers (V680-HA63□) V680-series Antennas (V680-H□□) One or two channels	
Applicable ID Tags	V680-series ID Tags (V680-D□□)		
No. of allocated unit numbers	1	2	
No. of allocated words	10 words	20 words	
Control protocol	Special protocol		
Data exchange methods with CPU Unit	Special I/O Unit Area: CIO 2000 to CIO 2959	Constant data exchange of 10 words/Unit	CPU Unit to ID Sensor Unit Unit controls, communications processing specification, data storage area specification
			ID Sensor Unit to CPU Unit Unit information, results information, processing results monitor
	Special I/O Unit words in DM Area: D20000 to D29599	100 words/Unit transferred when power is turned ON or when restarting the Unit	CPU Unit to ID Sensor Unit System Settings, Auto Wait Time Setting, Write Protection Disable Setting, Antenna Connection Setting, Results Monitor Output, Test Setting, Run/Test Switching Method Setting
Data transfer quantity	2,048 bytes max. (160 bytes/scan) (See note 3.)	2,048 bytes max./channel (160 bytes/scan) (See note 3.)	
Operating modes	Run Mode		
	Test Mode	<ul style="list-style-type: none"> • Communications tests • Distance level measurements • Read speed level measurements • Write speed level measurements • Noise level measurements • Communications success rate measurements 	
Diagnostic functions	(1) CPU watchdog timer (2) Communications error detection with ID Tag (3) Antenna power supply error		

- Note 1.** "Rack" indicates either the CPU Rack or an Expansion Rack.
- 2.** The V680-H01 Antenna can be connected only to the CJ1W-V680C11 ID Sensor Unit. It cannot be used with the CJ1W-V680C12 ID Sensor Unit.
- 3.** If using Intelligent I/O Instructions is specified as the data transfer method, up to 2,048 bytes can be transferred in one scan.

Communications Function Specifications

	CJ1W-V680C11	CJ1W-V680C12
Communications control	(1) Tag Communications Speed (Normal Mode or High-speed Mode) (2) Write Verification (3) Auto Wait Time Setting (4) UID Addition Setting (5) Write Protection Disable Setting (6) Antenna Connection Setting (One-channel ID Sensor Unit (CJ1W-V680C11)) (7) Results Monitor Output Setting	
Commands	Read Write Bit Set/Bit Clear Mask Bit Write Calculation Write Data Fill Data Check Number of Writes Control Read with Error Correction Write with Error Correction UID Read Noise Measurement	Read Write Bit Set/Bit Clear Mask Bit Write Calculation Write Data Fill Data Check Number of Writes Control Copy Read with Error Correction Write with Error Correction UID Read Noise Measurement
Communications specification	Single trigger Single auto Repeat auto FIFO trigger (See note) FIFO repeat (See note) Multi-access trigger (See note) Multi-access repeat (See note)	

Note: FIFO trigger, FIFO repeat, Multi-access trigger, and Multi-access repeat specification cannot be used for communicating with V680-D1KP□□ Tags.

Operating Procedure

The operating procedure for an ID Sensor Unit is shown in the following flowchart.

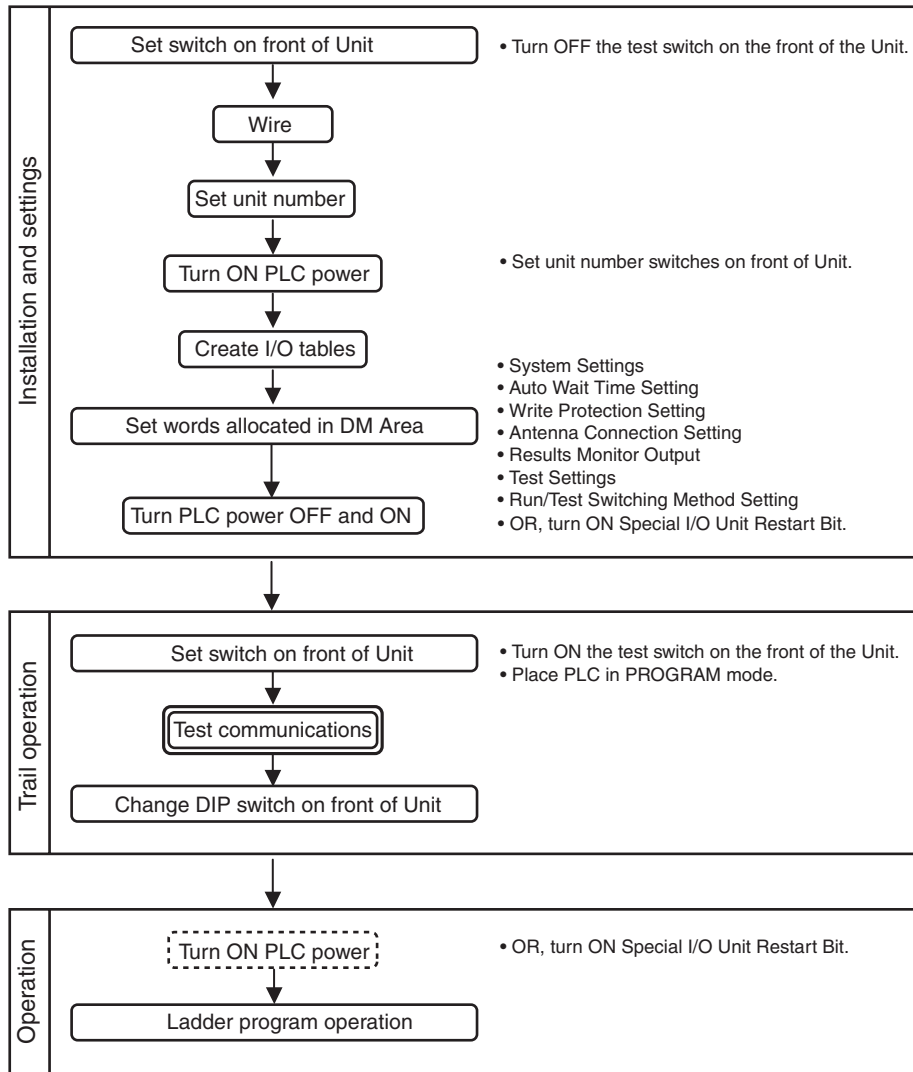

- When using CX-Programmer V3.0 or later with the CJ1W-V680C12, “I” will be displayed before addresses for inputs in the ladder diagram and “Q” will be displayed before addresses for outputs for operation data. In the CX-Programmer’s I/O Table Window, select SIOU/C200H ASCII Unit (A) and then, from the Enter SIOU Details Window, set the Address per Unit to 2, the Input Words to 3, and the Output Words to 7, and select the Repeat IN/OUT for each Address per Unit option.
- When using CX-Programmer V2.0 or later with the CJ1W-V680C11, “I” will be displayed in the ladder diagram before address for inputs and “Q” will be displayed before addresses for outputs for operation data.

Operating Procedure Example

The following is an operating procedure example for the following conditions.
Reading 10 Bytes of Data from ID Tag Address 0010 Using a Trigger.

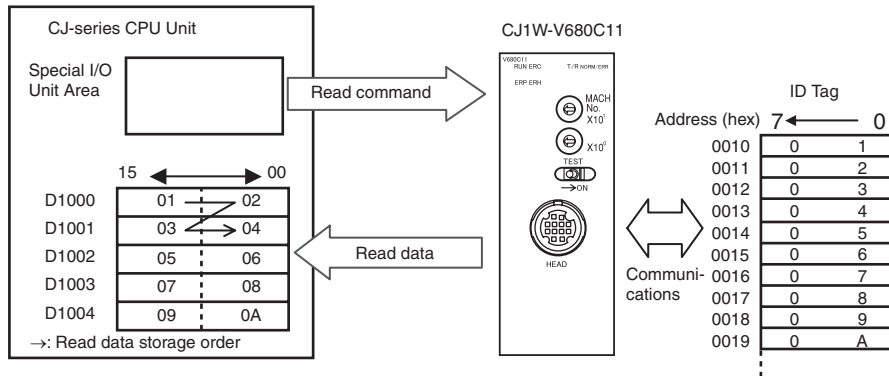

• Special I/O Unit Area Settings

Unit number: 00

Command: Read

Communications specification: Trigger

Read data storage order: Leftmost → Rightmost

First ID Tag read address: 0010 hex

Number of ID Tag read bytes: 10 bytes

Read data storage destination: D1000 to D1004

■ ID Sensor Unit Settings

1. Test Switch (Set on Unit's front panel.)

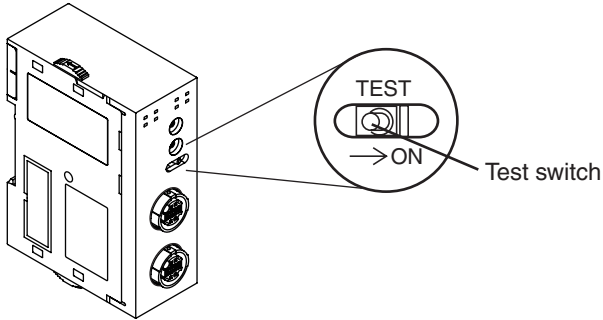

2. Mounting and Installation

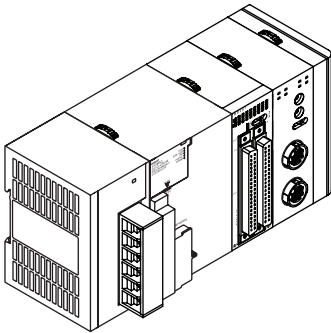

3. Unit Number Setting

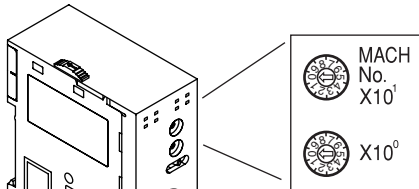

Set the unit number to 1, and the following words will be allocated to the Unit as a Special I/O Unit.

- CIO Area: CIO 2010 to CIO 2019
- DM Area: D20100 to D20199

4. PLC Power Supply ON

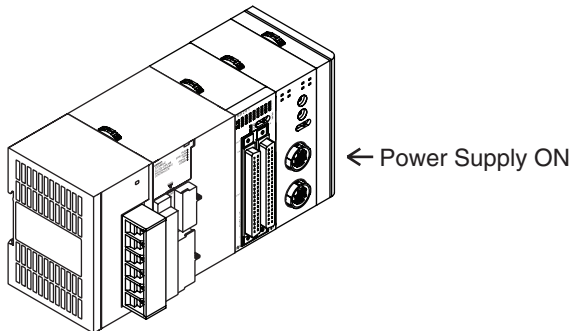

■ Creating I/O Tables

Always create the I/O tables after turning ON the PLC power supply. The I/O tables can be created from the Programming Console or CX-Programmer.

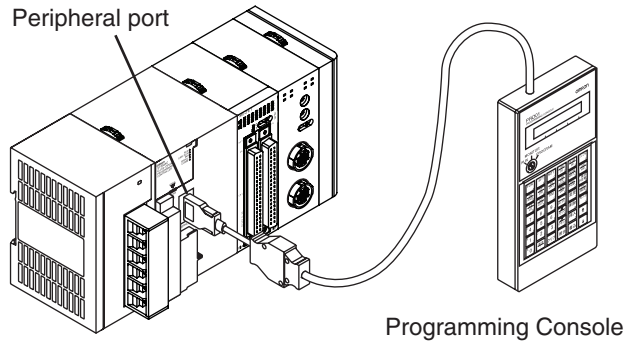

■ Initial Settings

1. Make the settings in the words allocated to Special I/O Units in the DM Area.



For information on setting the Special I/O Unit words in the DM Area, refer to *Parameter Settings in DM Area* on page 93.

CHECK!

 p. 93

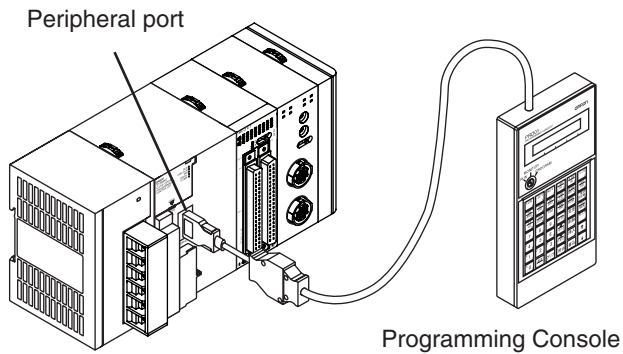

First word allocated to Unit in DM Area: $m = D20000 + (100 \times 0) = D20000$

DM address	Contents	Meaning															
		15	14	13	12	11	10	9	8	7	6	5	4	3	2	1	0
D20000	0 0 0 0	UID Addition 0: Disabled 1: Enabled				Test Mode Disable 0: Enabled 1: Disabled				Write Verification 0: Verification 1: No verification				Communications Speed 0: Normal 1: High-speed			
D20001	0 0 0 0	Auto Wait Time Setting range: 0000 to 9999 (x0.1 s) Factory setting: 0000 (infinite)															
D20002	0 0 0 0	Not used				Not used				Write Protection Disable 00: V680 method 01: Disabled 10: V600 method							
D20003	0 0 0 0	Not used				Not used				Not used				Antenna Connection 0: Standard Antenna 1: V680-H01			
D20004	0 0 0 0	Not used				Not used				Not used				Results Monitor Output 0: Communications time 1: Noise level			
D20005 to D20049	0 0 0 0	Not used															
D20050	0 0 0 0	Test Operation 00: Communications test A0: Distance level B0: Read speed level B1: Write speed level C0: Noise level C1: Communications success rate C2: Retry counts								Test Antenna 01: Antenna 1 02: Antenna 2							
D20051	0 0 0 0	Number of Test Bytes Setting range: 0000 to 0800 (byte)															
D20052 to D20079	0 0 0 0	Not used															
D20080	0 0 0 0	Not used												Run/Test Switching Method 1: CPU Unit 0: Test switch			
D20081	0 0 0 0	Not used												Tag Memory Setting 1: CA1D Mode 0: Standard Mode			
D20082 to D20089	0 0 0 0	Not used															
D20090	0 0 0 0	Not used												Data Transfer Setting 1: Use Intelligent I/O Instructions 0: Use cyclic transfer			
D20091 to D20099	0 0 0 0	Not used															

2. PLC Power Supply OFF and ON

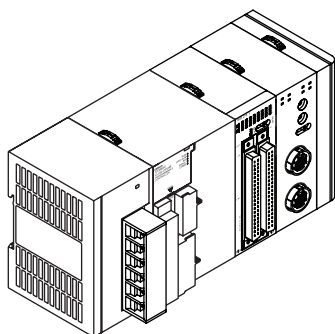

Power supply OFF → ON
(or turn ON the Unit Restart Bit)

Ladder Programming

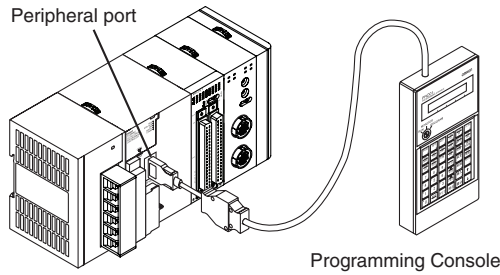

Set the Command, Communications Specification, Read Data Storage Order, First ID Tag Read Address, Number of Bytes to Read, and Read Data Storage Destination in CIO n+1 to CIO n+6 allocated in the Special I/O Unit Area (here, CIO 2001 to CIO 2006).

First word allocated to Unit in CIO Area: $CIO\ 2000 + 10 \times 0 = CIO\ 2000$

Word address	Contents			Meaning											
				15	14	13	12	11	10	9	8	7	6	5	4
CIO 2001	00	0	0	Command						Communications specification			Data order		
CIO 2002	00	10		First read address											
CIO 2003	00	0A		Number of read bytes											
CIO 2004	10	00		Read data storage location (rightmost 4 digits)											
CIO 2005	0	0	00	Data storage area			Bank specification*			Read data storage location (leftmost 2 digits)					
CIO 2006	00	00		---											

*: Always 0 when DM Area is specified. ---: Ignored.

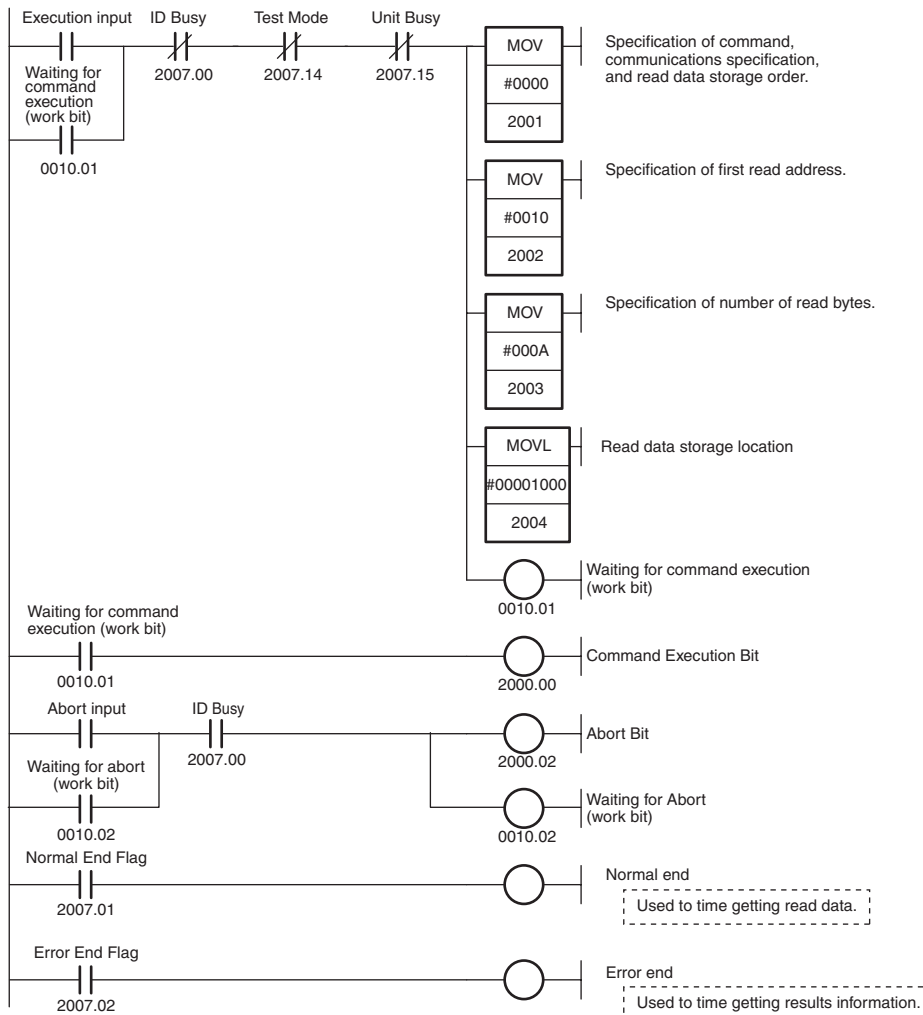

Part Names and Functions

Part Names

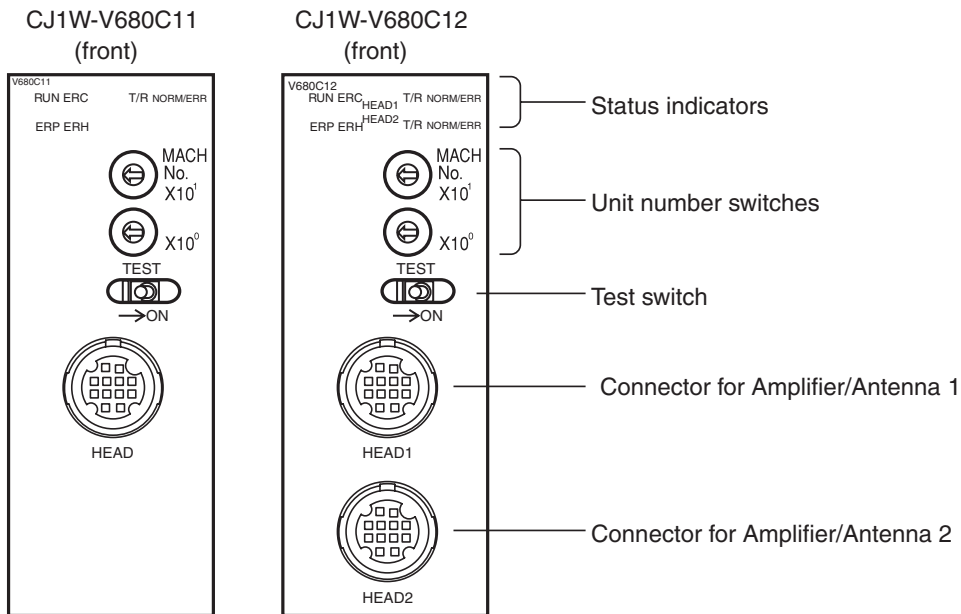

(Side)

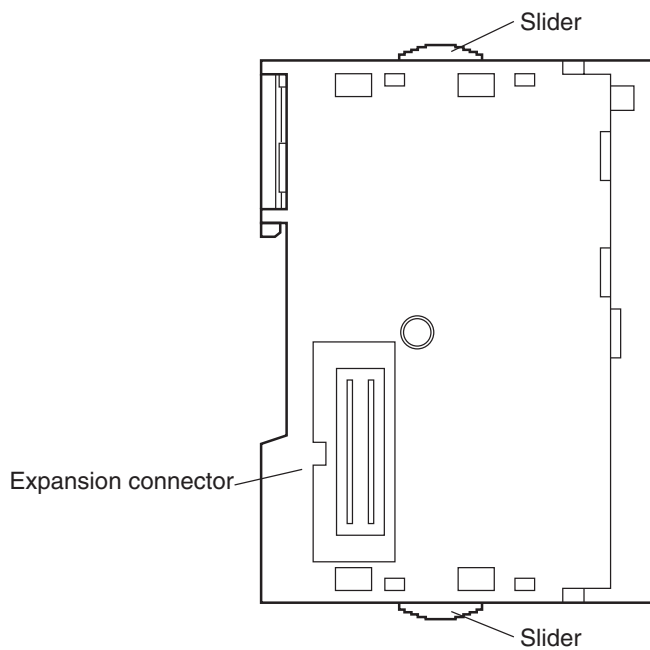

Indicators

The indicators show the operating status of the Unit. The relationship between the indicator status and the Unit status is shown in the following table.

Indicator		Name	Color	Meaning	
RUN		RUN	Green	○ Lit	The ID Sensor Unit is operating normally.
				● Not lit	The ID Sensor Unit is stopped.
ERC (Error in Controller)		Unit error	Red	○ Lit	An error has occurred in the ID Sensor Unit.
				● Not lit	No error has occurred in the ID Sensor Unit.
ERH (Error at CPU Unit)		CPU Unit error	Red	○ Lit	An error has occurred in the CPU Unit.
				● Not lit	No error has occurred in the CPU Unit.
ERP (Antenna Power Error)		Antenna power error	Red	○ Lit	An error has occurred in the power supply to the Antenna.
				● Not lit	The power supply to the Antenna is normal.
HEAD1 (Antenna 1)	T/R	Communicating	Yellow	○ Lit	Communications are active.
				● Not lit	Communications not being performed with the ID Tag.
	NORM/ERR	Normal end	Green	○ Lit	Communications with the ID Tag ended normally.
				● Not lit	The indicator is not lit in all other cases.
		Error end	Red	○ Lit	Communications with the ID Tag ended in an error.
				● Not lit	The indicator is not lit in all other cases.
HEAD2 (Antenna 2)	T/R	Communicating	Yellow	○ Lit	Communications are active.
				● Not lit	Communications not being performed with the ID Tag.
	NORM/ERR	Normal end	Green	○ Lit	Communications with the ID Tag ended normally.
				● Not lit	The indicator is not lit in all other cases.
		Error end	Red	○ Lit	Communications with the ID Tag ended in an error.
				● Not lit	The indicator is not lit in all other cases.

Unit Number Switches

Data exchange between the CPU Unit and ID Sensor Unit is performed using words allocated to the Unit in the Special I/O Unit Area and in the Special I/O Unit words in the DM Area. The words allocated to the ID Sensor Unit in these two areas are determined by the setting of the unit number switches on the Unit's front panel.

Switch No.	Unit No.	CJ1W-V680C11		CJ1W-V680C12	
		Words allocated in Special I/O Unit Area	Words allocated in DM Area	Words allocated in Special I/O Unit Area	Words allocated in DM Area
0	Unit 0	CIO 2000 to CIO 2009	D20000 to D20099	CIO 2000 to CIO 2019	D20000 to D20199
1	Unit 1	CIO 2010 to CIO 2019	D20100 to D20199	CIO 2010 to CIO 2029	D20100 to D20299
:	:	:	:	:	:
94	Unit 94	CIO 2940 to CIO 2949	D29400 to D29499	CIO 2940 to CIO 2959	D29400 to D29599
95	Unit 95	CIO 2950 to CIO 2959	D29500 to D29599	(Cannot be set)	



Test Switch

The test switch on the Unit's front panel is used to switch between Run Mode and Test Mode. Specify using the test switch in the Run/Test Switching Method Setting in the DM Area to enable using this switch.

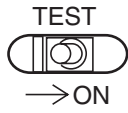

Status	Description
OFF	Run Mode (factory setting)
ON	Test Mode

Connections and Wiring

Connecting the Antenna

■ Connection Method

1. Holding the base of the connector, align the white mark on the Unit with the white mark on the connector and insert the connector.
2. Press in on the connector until it locks in place.

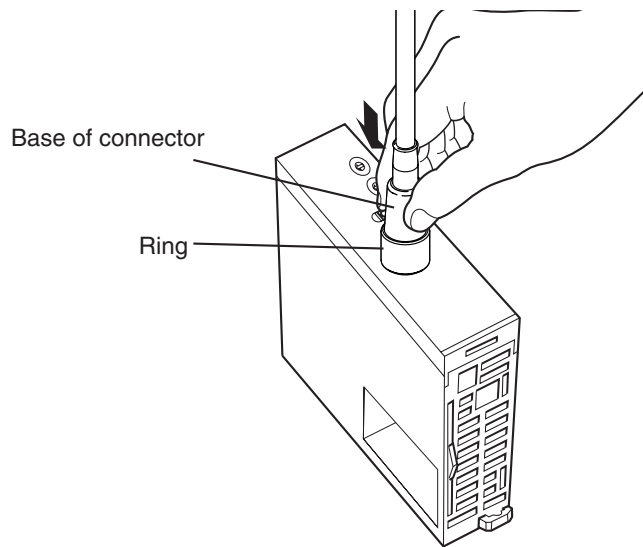

CHECK!

The connector will not lock into place if you hold onto the ring. Always hold onto the base of the connector.



CHECK!

The antenna that can be connected with the connector for Amplifier/Antenna is only V680-H01.

■ Removal Method

1. Hold onto the ring and pull straight out.

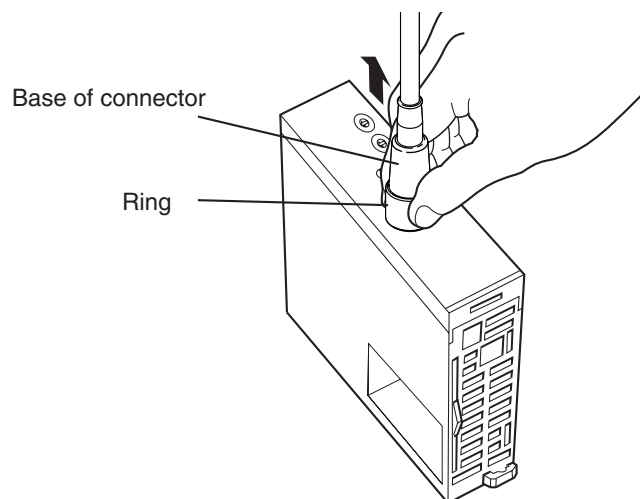

CHECK!

The connector cannot be removed if you hold onto the base of the connector. Never pull on the cable with excessive force. The connectors may be broken or damaged.



CHECK!

Connecting or disconnecting the connector with power to the Unit turned ON may cause the Unit to be damaged or malfunction.

Wiring for Safety and Noise Immunity

Antenna Cable and I/O Signal Lines

Wire the Antenna cable and I/O signal lines in separate ducts from power circuit cables both inside and outside the control panel.

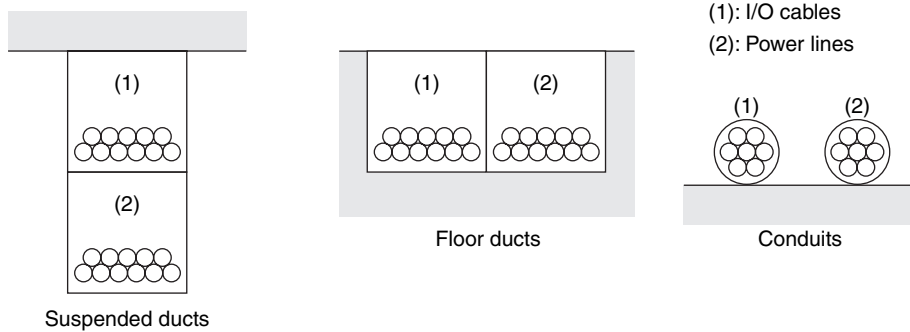

If the same ducts must be used, shielded cables can be used to increase resistance to noise. If a shielded cable is used, connect one end of the shield to ground.

Countermeasures for Inductive Loads

If I/O is connected to an inductive load, connect a surge killer or diode in parallel with the load.

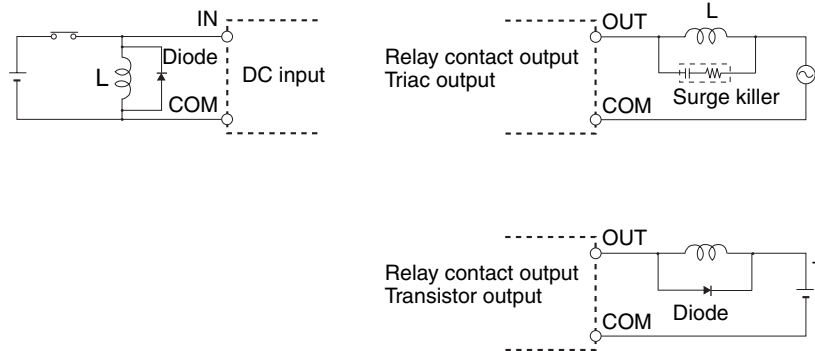

Use surge killers and diodes that meet the following conditions:

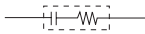
Surge Killers 

Resistance: 50 Ω
Capacitance: 0.47 μF
Voltage: 200 V

Diodes 

Inrush withstand voltage: 3 times load voltage min.
Average rectified current: 1 A

• **Noise Countermeasures for External Wiring**

Consider the following items when wiring external lines, such as the Antenna cable, I/O lines, power supply lines, and high-power lines.

- When using multiconductor cables for signal lines, do not use the same cable for both I/O lines and other control lines.
- When Racks are installed in parallel with each other, keep them separated by at least 300 mm.

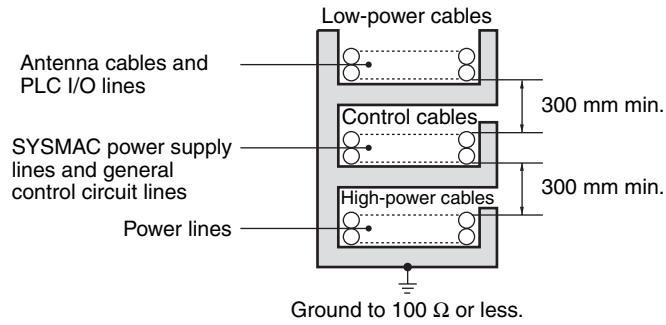

- When placing cables in the same duct, separate them with grounded iron plates.

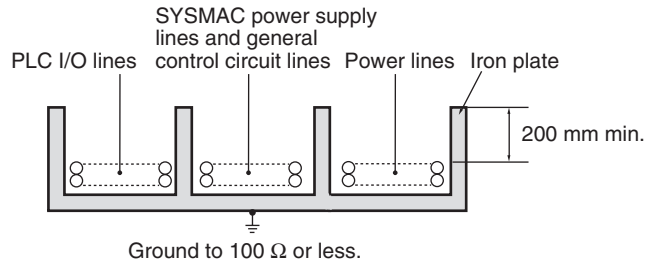

MEMO

SECTION 4

Data Exchange with the CPU Unit

☒ Outline of Data Exchange	62
☒ Initial Settings Data	66
☒ I/O Data Allocations	68

Outline of Data Exchange

Data is exchanged between the CS/CJ-series CPU Unit and CS1W-V680C11/C12 or CJ1W-V680C11/C12 ID Sensor Unit through I/O words allocated in the Special I/O Unit Area and initial setting words allocated in the DM Area.

- **I/O Data**

Words are allocated in the Special I/O Unit Area of the CPU Unit for ID Sensor Unit I/O data, including Unit Controls, commands, results information, etc., according to the unit number. This data is exchanged continuously during the I/O refresh period.

- **Initial Settings Data**

Words are allocated to the ID Sensor Unit in the DM Area of the CPU Unit for ID Sensor Unit initial settings, including the System Settings and Auto Wait Time Settings, Test Settings, etc., according to the unit number. This data is transferred when the power supply is turned ON or when restarting the Unit.

- **Test Settings Data**

Words are allocated to the ID Sensor Unit in the DM Area of the CPU Unit for test settings, including the Test Operation, Test Antenna, and Number of Test Bytes according to the unit number. This data is transferred when the power supply is turned ON.

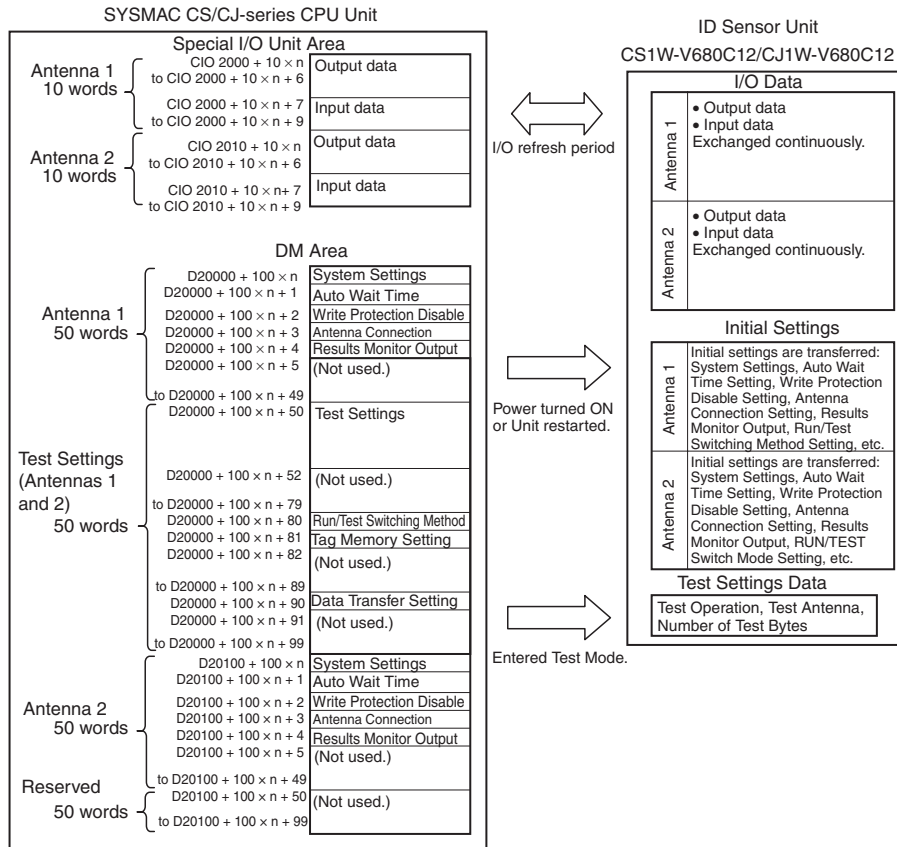
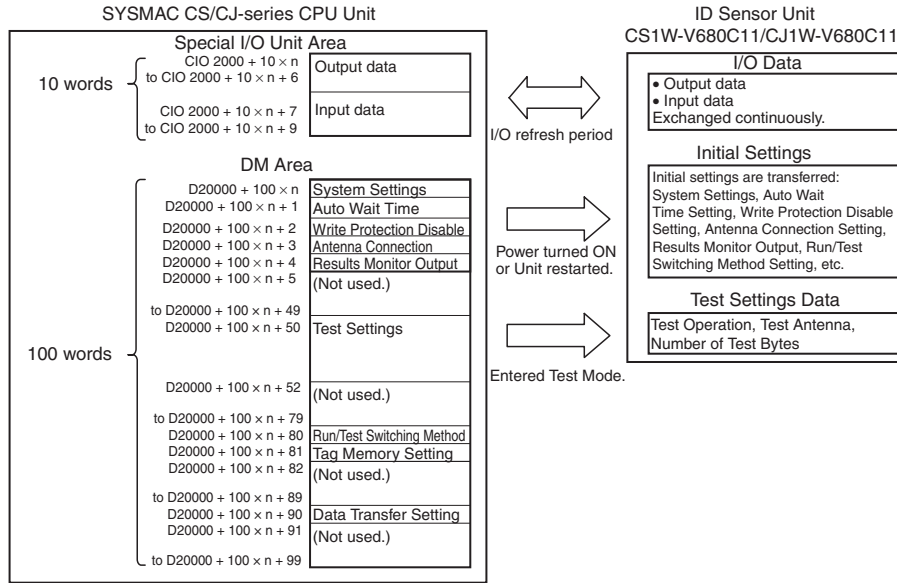

Unit Number Setting

The words allocated to the ID Sensor Unit in the Special I/O Unit Area and in the DM Area are determined by the unit number setting on the Unit's front panel.

CS1W-V680C11/C12

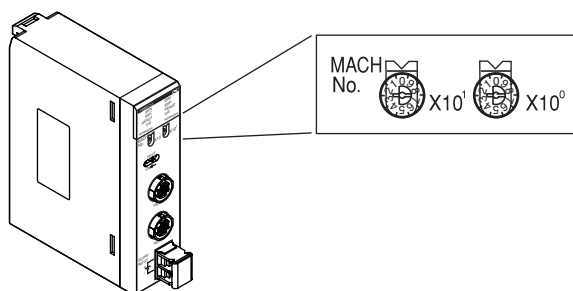

CJ1W-V680C11/C12

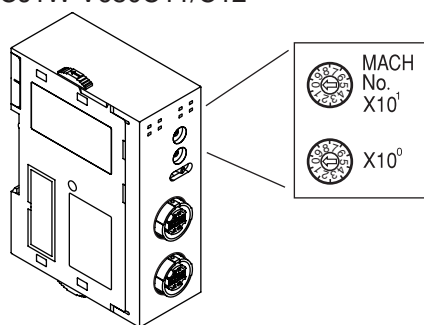

Switch No.	Unit No.	CS1W-V680C11/ CJ1W-V680C11		CS1W-V680C12/ CJ1W-V680C12	
		Words allocated in Special I/O Unit Area	Words allocated in DM Area	Words allocated in Special I/O Unit Area	Words allocated in DM Area
0	Unit 0	CIO 2000 to CIO 2009	D20000 to D20099	CIO 2000 to CIO 2019	D20000 to D20199
1	Unit 1	CIO 2010 to CIO 2019	D20100 to D20199	CIO 2010 to CIO 2029	D20100 to D20299
:	:	:	:	:	:
94	Unit 94	CIO 2940 to CIO 2949	D29400 to D29499	CIO 2940 to CIO 2959	D29400 to D29599
95	Unit 95	CIO 2950 to CIO 2959	D29500 to D29599	(Cannot be set)	



- If the same unit number is set for more than one Special I/O Unit, a fatal error (No. duplication error on CX-Programmer or Unit Number Duplication on Programming Console), and the PLC will not operate.
- When a Two-channels ID Sensor Unit (CS1W-V680C12 or CJ1W-V680C12) is used, two unit numbers are allocated.

Special I/O Unit Restart Bits

Unit operation can be restarted after DM Area settings have been changed or after an error has been corrected by turning the power supply to the PLC OFF and ON or by turning ON the Special I/O Unit Restart Bit.

• CS-series Special I/O Unit Restart Bits

Bit address	Function	
A50200	Unit 0 Restart Bit	The Unit will be restarted when the corresponding bit is turned ON. After the Unit has finished restarting, the corresponding bit will be automatically turned OFF.
A50201	Unit 1 Restart Bit	
⋮	⋮	
A50215	Unit 15 Restart Bit	
A50300	Unit 16 Restart Bit	
⋮	⋮	
A50715	Unit 95 Restart Bit	

• CJ-series Special I/O Unit Restart Bits

Bit address	Function	
A50200	Unit 0 Restart Bit	The Unit will be restarted when the corresponding bit is turned ON. After the Unit has finished restarting, the corresponding bit will be automatically turned OFF.
A50201	Unit 1 Restart Bit	
⋮	⋮	
A50215	Unit 15 Restart Bit	
A50300	Unit 16 Restart Bit	
⋮	⋮	
A50715	Unit 95 Restart Bit	

- Exchanged data will be all zeros while the Unit is being restarted.



- Replace the ID Sensor Unit if an error cannot be cleared even after turning the power supply OFF and ON or after turning ON the Special I/O Unit Restart Bit.

Initial Settings Data

DM Area Allocations and Contents

The initial settings for the ID Sensor Unit are performed using the words allocated to the ID Sensor Unit as a Special I/O Unit in the DM Area.

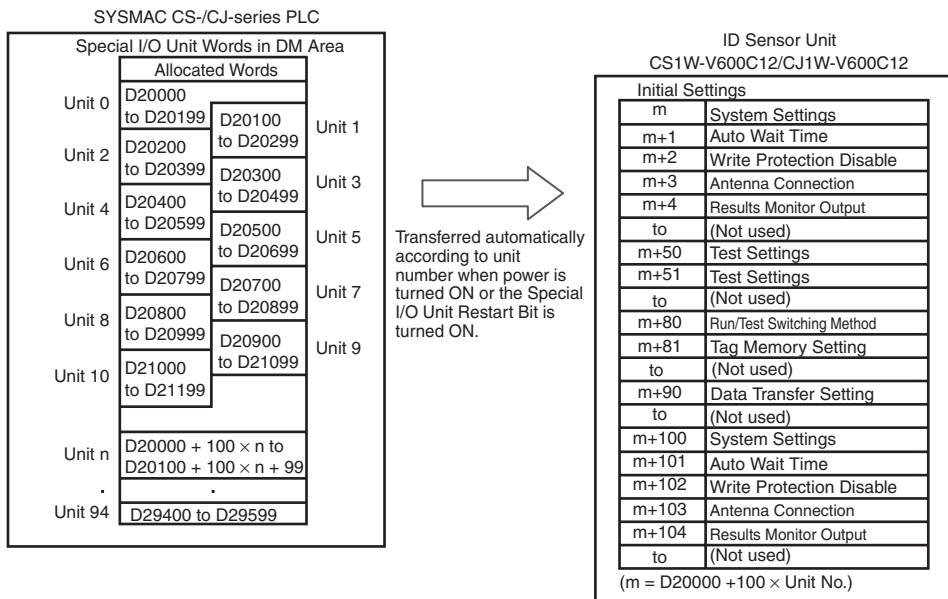
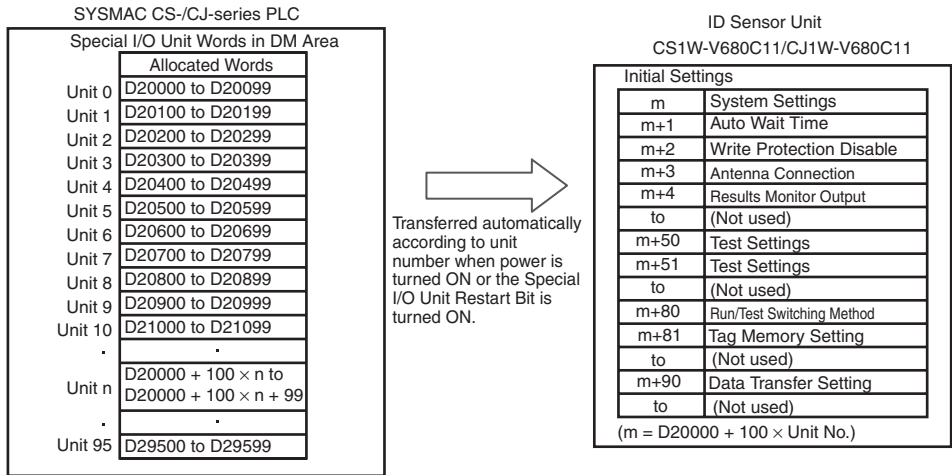

- The words allocated to the ID Sensor Unit as a Special I/O Unit in the DM Area are determined by the setting of the unit number switches on the Unit's front panel. Set unit numbers so that the same words are not allocated to more than one Unit. (Refer to p. 64 for the setting method.)
- If the same unit number is set for more than one Special I/O Unit, a fatal error (No. duplication error on CX-Programmer or Unit Number Duplication on Programming Console), and the PLC will not operate.

DM Area Contents (Same for Run or Test Mode)

The following initial settings are set in the words allocated in the DM Area.

DM Area address		Bit No.	Type	Description	Setting	Reference
Antenna 1 of CS1W-V680C11, CS1W-V680C12, CJ1W-V680C11, or CJ1W-V680C12	Antenna 2 of CS1W-V680C12 or CJ1W-V680C12					
m	m+100	12 to 15	System Settings	UID Addition Setting	0: Disabled 1: Enabled	p. 93
		08 to 11		Test Mode Disable Setting	0: Enabled 1: Disabled	
		04 to 07		Setting for Write Verification	0: Verification 1: No verification	
		00 to 03		Tag Communications Speed Setting	0: Normal mode 1: High-speed mode	
m+1	m+101	00 to 15	Auto Wait Time Setting	The ID Tag timeout time when the Communications Specification is single auto or repeat auto. An ID Tag Missing Error will be returned if this value is exceeded.	0001 to 9999 (×0.1s) 0000: Infinite	p. 95
m+2	m+102	08 to 15	Write Protection Disable Setting	Not used.	---	p. 95
		00 to 07		Write Protection Disable (V680 method/Disabled/V600 method)	00: V680 method 01: Disabled 02: V600 method	
m+3	m+103	04 to 15	Antenna Connection Setting	Not used.	---	p. 96
		00 to 03		Antenna Connection	0: Standard Antenna 1: V680-H01	
m+4	m+104	04 to 15	Results Monitor Output Setting	Not used.	---	p. 96
		00 to 03		Results Monitor Output	0: Communications time 1: Noise level	
m+50	---	08 to 15	Test Settings (Both Antennas 1 and 2)	Test Operation	00: Communications test A0: Distance level B0: Read speed level B1: Write speed level C0: Noise level C1: Communications success rate	p. 97
		00 to 07		Test Antenna	01: Antenna 1 02: Antenna 2	
m+51	---	00 to 15		Number of Test Bytes	0000 to 0800 hex (bytes)	
m+80	---	04 to 15	Run/Test Switching Method Setting (Both Antennas 1 and 2)	Not used.	---	p. 98
		00 to 03		Run/Test Switching Method Setting	0001: CPU Unit 0000: Test switch	
m+81	---	04 to 15	Tag Memory Setting (Both Antennas 1 and 2)	Not used.	---	p. 98
		00 to 03		Tag Memory Setting	0: Standard Mode 1: CA1D Mode	
m+90	---	04 to 15	Data Transfer Setting (Both Antennas 1 and 2)	Not used.	---	p. 98
		00 to 03		Data Transfer Setting	0: Use cyclic transfer 1: Use Intelligent I/O Instructions	



• First word allocated to Unit in DM Area: $m = D20000 + 100 \times \text{Unit number}$

I/O Data Allocations

Special I/O Unit Area Allocations and Contents

I/O data exchange for the ID Sensor Unit is performed using the words allocated to the ID Sensor Unit as a Special I/O Unit in the Special I/O Unit Area.

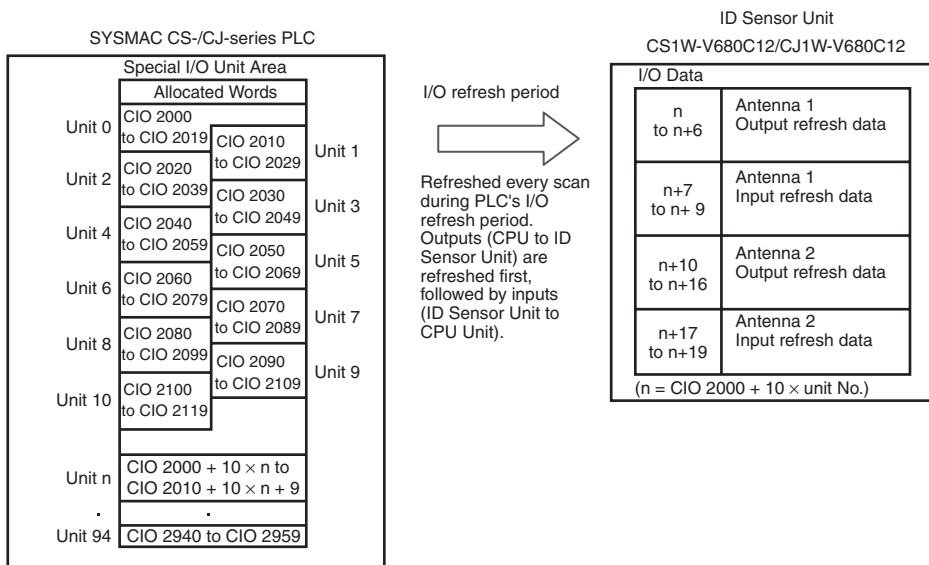
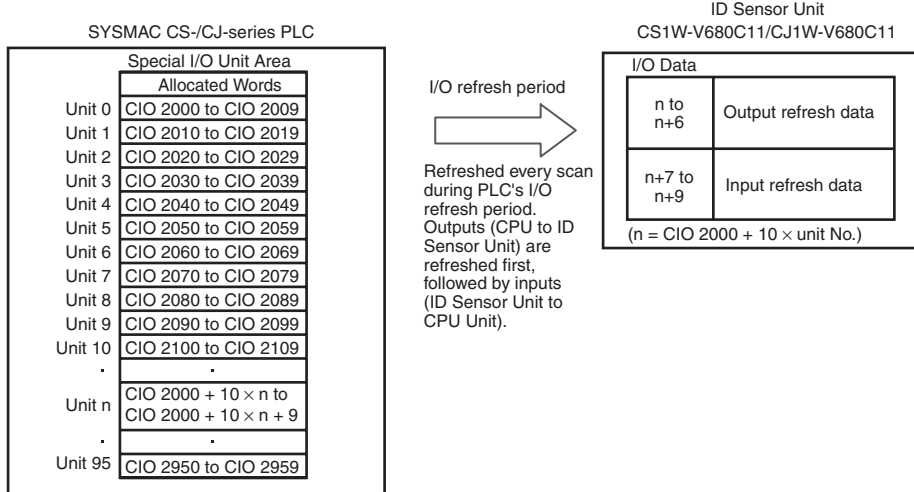

- The words allocated to the ID Sensor Unit in the Special I/O Unit Area are determined by the setting of the unit number switches on the Unit's front panel. Set unit numbers so that the same words are not allocated to more than one Unit. (Refer to p. 64 for the setting method.)
- If the same unit number is set for more than one Special I/O Unit, a fatal error (No. duplication error on CX-Programmer or Unit Number Duplication on Programming Console), and the PLC will not operate.

Special I/O Unit Bit Allocations

The words in the Special I/O Unit Area are allocated as shown in the following table.

■ Outputs

I/O	Word address		Bit No.	Type	Bit name	Description	
	Antenna 1 of CS1W-V680C11, CS1W-V680C12, CJ1W-V680C11, or CJ1W-V680C12	Antenna 2 of CS1W-V680C12 or CJ1W-V680C12					
Output	n	n+10	15	Unit Controls	Run/Test Bit	Turn ON for Test Mode, turn OFF for Run Mode. (Enabled only when DM=m+80 is 0001.)	
			03 to 14		---	Not used	
			02		Abort Bit	Execution is aborted if this bit is turned ON during command execution. If communications are aborted for an FIFO trigger communications specification, prohibiting communications with any ID Tags inside the communications range will be cleared.	
			01		Error Reset Bit	If this bit is turned ON while the ID Sensor Unit is waiting for the Command Execution Bit to be turned ON, the Results Information (CIO n+8) will be cleared.	
			00		Command Execution Bit	When this bit is turned ON, the ID Sensor Unit will interpret the command and start execution.	
	n+1	n+11	08 to 15	Command	Command Code	Specify the command to be executed.	
					04 to 07	Communications Specification	Specify the communications method with the ID Tag.
					00 to 03	Processing Specification	Specify details of command execution.
	n+2	n+12	00 to 15		Processing Address	Specify the processing start address in the ID Tag.	
	n+3	n+13	00 to 15		Number of Processing Bytes	Specify the number of processing bytes in the ID Tag	
	n+4	n+14	00 to 15	Data Storage Area	Data Storage Word Address (rightmost 4 digits)	Specify the storage word address in BCD.	
					Data Storage Area	Specify the data storage area.	
Bank Specification					If the EM Area is specified, specify the bank number.		
n+5	n+15	12 to 15		Data Storage Word Address (leftmost 2 digits)	Specify the storage word address in BCD.		
		08 to 11					
		00 to 07					
n+6	n+16	00 to 15	Option	Command Option	Specify command option.		

• First word allocated to Unit in CIO Area: $n = \text{CIO } 2000 + 10 \times \text{Unit number}$



Command and Option Settings

Command name	Type	Command					Option	Data stored in Data Storage Area (See note 4.)	Reference	
	Word address	n+1			n+2	n+3	n+6			
	Name	Command Code (hex)	Communications Specification (hex) (See note 2.)	Processing Specification (hex) (See note 3.)	Processing Address (hex)	Number of Processing Bytes (hex)	Command Option			
Read		00	0: Trigger 1: Single auto 2: Repeat auto 3. FIFO trigger 4. FIFO repeat 5. Multi-access trigger 6. Multi-access repeat	Data storage order 0: Leftmost → Rightmost 1: Rightmost → Leftmost	0000 to FFFF	0001 to 0800	---	Read data	Page 126	
Write		01			0000 to FFFF	0001 to 0800	---	Write data	Page 127	
Bit Set		02			0000 to FFFF	0001 to 0004	---	Designation Data for Bit Set	Page 128	
Bit Clear		03			0000 to FFFF	0001 to 0004	---	Designation Data for Bit Clear	Page 129	
Mask Bit Write		04			0000 to FFFF	---	Designation Data for Mask 0000 to FFFE	Write data	Page 130	
Calculation Write		05			0: Add 1: Subtract	0000 to FFFF	0001 to 0004	Operation value 0000 to FFFF	Calculation result	Page 132
Data Fill		06			0: Bytes 1: Words	0000 to FFFF	0001 to 0800 0000: All	Fill data 0000 to FFFF	---	Page 133
Data Check		07			0: Trigger 1: Single auto	0: Calculation 1: Verification	0000 to FFFD	0003 to 0800	---	Page 134
Number of Writes Control		08			0: Add 1: Subtract	0000 to FFFD	---	No. to add 0000 to 00FF	Result of number of writes calculation	Page 135
Copy (See note 1.)		09			---	Read address 0000 to FFFF	0001 to 0800	Write address 0000 to FFFF	---	Page 136
Read with Error Correction		0A	0: Trigger 1: Single auto 2: Repeat auto 3. FIFO trigger 4. FIFO reader 5. Multi-access trigger 6. Multi-access repeat	Data storage order 0: Leftmost → Rightmost 1: Rightmost → Leftmost	0000 to FFFA	0001 to 01FE	---	Read data	Page 137	
Write with Error Correction		0B			0000 to FFFA	0001 to 01FE	---	Write data	Page 138	
UID Read		0C			---	---	---	Read data	Page 139	
Noise Measurement		10	0: Trigger	---	---	---	Measurement results	Page 140		

Note 1. The Copy command cannot be used on the CS1W-V680C11/CJ1W-V680C11.

2. Refer to *Communications Specifications* for communications specifications.

 p. 85

3. Refer to *Designating Processing Specifications* for designation methods.

 p. 71

4. Refer to *Designating Data Storage Areas* for designation methods.

 p. 71

• Designating Processing Specifications

Commands	Processing Specification
Read Write Bit Set Bit Clear Mask Bit Write Read with Error Correction Write with Error Correction UID Read	<p>0: Leftmost to Rightmost</p> <p>1: Rightmost to Leftmost</p>
Calculation Write	0: Add
Number of Writes Control	1: Subtract
Data Fill	0: Bytes (Rightmost 8 bits) 1: Words
Data Check	0: Calculation (write) 1: Verification

• Designating Data Storage Areas

Word address		n+5			n+4
Bit No.		15 to 12	11 to 08	07 to 00	15 to 00
Area	Specifiable range	Area specification	Bank specification	Address (leftmost 2 digits)	Address (rightmost 4 digits)
DM	D00000 to D32767	0 hex	Always 0	000000 to 032767 (BCD)	
CIO	CIO 0000 to CIO 6143	1 hex	Always 0	000000 to 006143 (BCD)	
WR	W000 to W511	2 hex	Always 0	000000 to 000511 (BCD)	
HR	H000 to H511	3 hex	Always 0	000000 to 000511 (BCD)	
AR	A000 to A959	4 hex	Always 0	000000 to 000959 (BCD)	
EM	E00000 to E32767	5 hex	0 to C hex	000000 to 032767 (BCD)	
TIM	T0000 to T4095	6 hex	Always 0	000000 to 004095 (BCD)	
CNT	C0000 to C4095	7 hex	Always 0	000000 to 004095 (BCD)	



- If there is a mistake in designating the command and option, the Command Error Flag (CIO n+8, bit 00) in the Results Information will turn ON, and the command will not be executed.
- If there is a mistake in designating the data storage area, the Data Storage Area Specification Error Flag (CIO n+8, bit 01) in the Results Information will turn ON, and the command will not be executed.

■ Inputs

I/O	Word address		Bit No.	Type	Bit name	Description
	Antenna 1 of CS1W-V680C11, CS1W-V680C12, CJ1W-V680C11, or CJ1W-V680C12	Antenna 2 of CS1W-V680C12 or CJ1W-V680C12				
Input	n+7	n+17	15	Unit Status	Unit Busy Flag	Turns ON when there is an ID Sensor Unit error.
			14		Test Mode Flag	Turns ON during Test Mode.
			13		Antenna Power Supply Error Flag	Turns ON when there is an error in the Unit power supply or the external power supply.
			12		Memory Error Flag	Turns ON when there is an error in ID Sensor Unit memory.
			11		Antenna Error Flag	The DM Area setting and V680-H01 Antenna connection status do not match. Too many Antennas are connected or the specified power consumption has been exceeded.
			03 to 10		---	Not used
			02		Error End Flag	Turns ON when there is an ID Sensor Unit error.
			01		Normal End Flag	Turns ON for one scan when processing ends normally.
			00		ID Busy Flag	Turns ON while communications are in progress.

I/O	Word address		Bit No.	Type	Bit name	Description
	Antenna 1 of CS1W-V680C11, CS1W-V680C12, CJ1W-V680C11, or CJ1W-V680C12	Antenna 2 of CS1W-V680C12 or CJ1W-V680C12				
Input (cont'd)	n+8	n+18	15	Results Information	Antenna Error Flag (Error Code: 7C)	Turns ON when an error occurs because an Antenna is not connected. Turns ON when the power is not correctly supplied to the Antenna.
			14		Verification Error Flag (Error Code: 71)	Turns ON when data cannot be written correctly to the ID Tag (only when verification is specified).
			13		ID Tags Address Error Flag (Error Code: 7A)	Turns ON when execution is not possible because the processing address is not specified correctly.
			12		ID Tag Communications Error Flag (Error Code: 70)	Turns ON when communications cannot be completed normally because an error occurred in communications with the ID Tag.
			11		Write Protection Error Flag (Error Code: 7D)	Turns ON when an attempt is made to write to a write-protected area. Turns ON when the ID Tag is not an applicable model.
			10		ID Tag Missing Error Flag (Error Code: 72)	Turns ON when the communications specification is designated as a trigger but there is no ID Tag in the Antenna's communications area. Turns ON when there is no ID Tag in the Antenna's communications area before the Auto Wait Time elapses.
			09		ID System Error 1 (Error Code: 79)	System error
			08		ID System Error 2 (Error Code: 7E)	System error
			07		ID System Error 3 (Error Code: 7F)	System error
			05 to 06		---	Not used
			04		Status Flag (Error Code: 76)	Turns ON for a Calculation Write command if addition results in an overflow or subtraction results in an underflow. Turns ON when a difference is found for the verification results for a Data Check command. Turns ON when the specified number of writes is exceeded for a Number of Writes Control command. Turns ON for a Copy command if an error occurs when writing after data has been read. Turns ON when a 2-bit or larger memory error cannot be corrected by the Read with Error Correction command.
			03		Error Correction Flag (Error Code: 77)	Turns ON when a 1-bit error correction was performed for a read error.
			02		---	Not used
			01		Data Storage Area Specification Error Flag (Error Code: 14)	Turns ON when an illegal area is specified for the data storage area.
			00		Command Error Flag (Error Code: 14)	Turns ON when there is an error in the setting for the Command, Communications Specification, Processing Address, or Number of Processing Bytes. Turns ON when an attempt is made to execute the Copy command for the CS1W-V680C11/CJ1W-V680C11.

I/O	Word address		Bit No.	Type	Bit name	Description
	Antenna 1 of CS1W-V680C11, CS1W-V680C12, CJ1W-V680C11, or CJ1W-V680C12	Antenna 2 of CS1W-V680C12 or CJ1W-V680C12				
Input (cont'd)	n+9	n+19	00 to 15	Monitor	Processing Results Monitor	<ul style="list-style-type: none"> ■ Run Mode • Communications Time Normal end: Processing time (1 to 9999 x 10 ms) Max. error: 10 ms Error end: "E0" + "Error Code" Other: "0000" • Noise Level Communications end: "C0" + "00" to "99" Measurement error: "E0" + "Error Code" Other: "0000" ■ Test Mode Normal end: "Command code" + <Results> Error end: "E0" + "Error Code" Other: "0000" <p>Cleared when the power supply is turned ON or command execution starts.</p>

• Processing Results Monitor Data

Run Mode

Word address	n+9			
	15 to 12	11 to 08	07 to 04	03 to 00
When the power supply is turned ON or communications are started	0	0	0	0
At a normal end	Processing time (1 to 9999 × 10 ms) (hex) or Noise level (C0000 to C099)			
At an error end	E	0	Error code	

Communications Test Mode

Word address	n+9			
	15 to 12	11 to 08	07 to 04	03 to 00
When the power supply is turned ON or communications are started	0	0	0	0
At a normal end	Processing time (1 to 9999 × 10 ms) (hex)			
At an error end	E	0	Error code	

Distance Level Measurement

Word address	n+9			
	15 to 12	11 to 08	07 to 04	03 to 00
At a normal end	A	0	Distance level measurement results (00 to 06)	
At an error end	E	0	Error code	



When a V680-H01 Antenna is connected, tests other than the communications test cannot be performed. No matter which test is set, only the Tag communications test operation will be performed.

Read Speed Level Measurement

Word address Bit No.	n+9			
	15 to 12	11 to 08	07 to 04	03 to 00
When the power supply is turned ON or communications are started	0	0	0	0
At a normal end	B	0	Read speed level measurement results (EE, 01 to 06)	
At an error end	E	0	Error code	



When a V680-H01 Antenna is connected, tests other than the communications test cannot be performed. No matter which test is set, only the Tag communications test operation will be performed.

Write Speed Level Measurement

Word address Bit No.	n+9			
	15 to 12	11 to 08	07 to 04	03 to 00
When the power supply is turned ON or communications are started	0	0	0	0
At a normal end	B	1	Write speed level measurement results (EE, 01 to 06)	
At an error end	E	0	Error code	



When a V680-H01 Antenna is connected, tests other than the communications test cannot be performed. No matter which test is set, only the Tag communications test operation will be performed.

Noise Level

Word address Bit No.	n+9			
	15 to 12	11 to 08	07 to 04	03 to 00
At a normal end	C	0	Noise level measurement results (00 to 99)	
At an error end	E	0	Error code	



When a V680-H01 Antenna is connected, tests other than the communications test cannot be performed. No matter which test is set, only the Tag communications test operation will be performed.

Read Communications Success Rate Measurement

Word address Bit No.	n+9			
	15 to 12	11 to 08	07 to 04	03 to 00
At a normal end	C	1	Communications success rate measurement results (EE, 01 to 99) (100%: FF)	
At an error end	E	0	Error code	



When a V680-H01 Antenna is connected, tests other than the communications test cannot be performed. No matter which test is set, only the Tag communications test operation will be performed.

• **Error Codes**

Error classification	Error Codes	Error
Communications error with ID Tag	7C	Antenna error
	71	Verification error
	7A	ID Tag address error
	70	ID Tag communications error
	7D	Write protect error
	72	ID Tag missing error
	79	ID system error 1
	7E	ID system error 2
	7F	ID system error 3
	76	Status error
	77	Error corrected
Host communications error	14	Data storage area specification error, command error

SECTION 5

ID Sensor Unit Functions

☒ Operating Modes	78
☒ Communications Specifications	85
☒ Parameter Settings in DM Area	93
☒ ID Tag Memory	99
☒ Write Protection	101
☒ ID Tag Service Life Check	108
☒ ID Tag Memory Check	112
☒ ID Tag Memory Error Correction	114

Operating Modes

The ID Sensor Unit has two operating modes: Run Mode and Test Mode

There are two ways to switch between the two operating modes.

1. The test switch on the Unit's front panel
2. A software switch in memory

Run Mode

In Run Mode, communications are performed when the Command Execution Bit (CIO n, bit 0) in the Special I/O Unit Area is turned ON. All commands can be used in this mode. Communications results and Unit status are shown on the status indicators and in the Unit Status (CIO n+7), Results Information (CIO n+8), and Processing Results Monitor (CIO n+9) in the Special I/O Unit Area.

Test Mode

Test Mode is used to simulate actual operation. By using Test Mode, communications capability can be measured easily in the actual operating environment. Test Mode is also useful for checking the installation and checking the system while it is operating. The following five operations can be performed in Test Mode.

Operation	Description
Tag communications test	Executes communications with an ID Tag and outputs the results to the Processing Results Monitor (CIO n+9) in the Special I/O Unit Area. When using a Two-channels ID Sensor Unit, the test will be performed alternately for Antennas 1 and 2.
Distance level measurement	Measures the Antenna and ID Tag installation distance in relation to the Tag communications range. The measurement results are output to the Processing Results Monitor (CIO n+9) in the Special I/O Unit Area. The results can also be checked on the Amplifiers operation indicators.
Write/read speed level measurement	Measures the number of times that communications can be performed consecutively based on the speed that Tags pass through the Antenna communications range. The measurement results are output to the Processing Results Monitor (CIO n+9) in the Special I/O Unit Area. The results can also be checked on the Amplifiers operation indicators.
Noise level measurement	Measures the ambient noise level in the installation environment. The measurement results are output to the Processing Results Monitor (CIO n+9) in the Special I/O Unit Area.
Communications success rate measurement	Communicates 100 times with an ID Tag with no retries. The measurement results are output to the Processing Results Monitor (CIO n+9) in the Special I/O Unit Area.



When a V680-H01 Antenna is connected, tests other than the communications test cannot be performed. No matter which test is set, only the Tag communications test operation will be performed.



- If the ID Sensor Unit is changed to Test Mode while a command is being executed, command execution will be completed and then Test Mode will be entered.
- If an ID Sensor Unit error occurs, communications will stop regardless of the operating mode.
- First word allocated to Unit in CIO Area: $n = \text{CIO } 2000 + 10 \times \text{Unit number}$

■ Using the Test Mode

1. Set the operation in Test Mode

The operation to be performed in Test Mode is set in the DM Area. The settings are listed in the following table.

Test Operation	<ul style="list-style-type: none"> • Communications test • Distance level • Read speed level • Write speed level • Noise level • Communications success rate
Test Antenna	<ul style="list-style-type: none"> • Antenna 1 • Antenna 2
Number of Test Bytes	0000 to 0800 hex (bytes)
Run/Test Switching Method	<ul style="list-style-type: none"> • CPU Unit • Test switch



CHECK!

For details on the settings for the operation in Test Mode, refer to *Test Settings* and *Run/Test Switching Method Setting*.



p. 97

2. Turn ON the test switch.

The Test Operation is started using the method set in the DM Area



CHECK!

To start Test Mode using the switch on the front of the Unit, set DM m+80 to 0000.
To start Test Mode using bit 15 of CIO n+0, set DM m+80 to 0001.



CHECK!

The test that is performed cannot be changed after entering Test Mode, even if the test settings in DM m+50 and DM m+51 are changed. Always set the test settings in DM m+50 and DM m+51 before entering Test Mode.

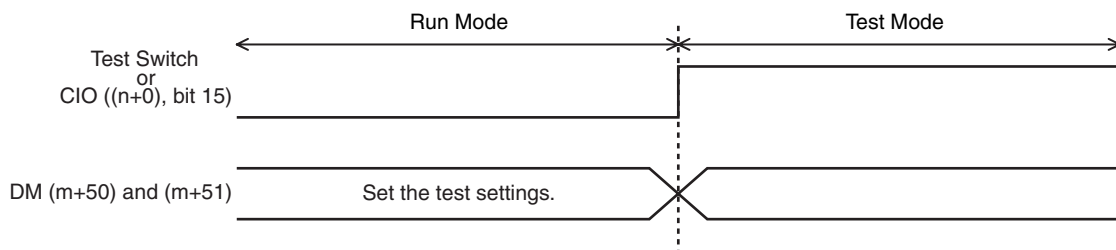

■ Communications Test

A communications test is used to execute communications with an ID Tag and output the communications results to the Processing Results Monitor (CIO n+9) in the Special I/O Unit Area. When using a Two-channels ID Sensor Unit, tag communications are executed alternately for Antennas 1 and 2.



CHECK!

The communications test checks only the read operation and does not check the write operation.



CHECK!

The communications test will be performed with the contents that was set in advance in DM m+50 and DM m+51. In the communications test, communications are executed alternately for Antennas 1 and 2, regardless of the specified Antenna number.

1. Set the method to use to switch between Run Mode and Test Mode.



CHECK!

To start Test Mode using the switch on the front of the Unit, set DM m+80 to 0000.
To start Test Mode using bit 15 of CIO n+0, set DM m+80 to 0001.



CHECK!

After setting DM Area data with the Support Software, reset the power supply to the PLC or turn ON the Special I/O Unit Restart Bit. The DM Area settings will be transferred to the ID Sensor Unit when the power supply turns ON or when the Special I/O Unit Restart Bit is turned ON.

2. Set the operation to perform in Test Mode.

Set DM m+50 to 0000 and set the number of test bytes in DM m+51.



CHECK!

DM Area addresses are given in reference to "m," where $m = D20000 + 100 \times \text{Unit number}$.

3. Turn ON the test switch.

The operation in Test Mode is started using the method set in the DM Area.



CHECK!

To start Test Mode using the switch on the front of the Unit, set DM m+80 to 0000.
To start Test Mode using bit 15 of (CIO n+0), set DM m+80 to 0001.

4. Communications with the ID Tag will begin.

Communications will be performed with the ID Tag and the communications results will be output to the Processing Results Monitor (CIO n+9) in the Special I/O Unit Area.

■ Distance Level Measurement

A distance level measurement allows for easy checking of the installation positions of Antennas and Tags.

This test operation measures the Antenna and Tag installation distance in relation to the Tag communications range. The measurement results are output to the Processing Results Monitor (CIO n+9) in the Special I/O Unit Area. The measurement results can also be checked on the Amplifiers operation indicators.



CHECK!

The distance level changes dramatically depending on the ambient environment. Use it as a guide for the installation position and test operation sufficiently in Run Mode using the actual installation environment. Levels higher than distance level 4 may not be displayed, but this does not indicate an error and performance in Run Mode will not be affected.



CHECK!

The communications test will be performed with the contents that was set in advance in DM m+50 and DM m+51.

1. Set the method to use to switch between Run Mode and Test Mode.



CHECK!

To start Test Mode using the switch on the front of the Unit, set DM m+80 to 0000.
To start Test Mode using bit 15 of CIO n+0, set DM m+80 to 0001.



CHECK!

After setting DM Area data with the Support Software, reset the power supply to the PLC or turn ON the Special I/O Unit Restart Bit. The DM Area settings will be transferred to the ID Sensor Unit when the power supply turns ON or when the Special I/O Unit Restart Bit is turned ON.

2. Set the operation to perform in Test Mode.

Set DM m+50 to A00X and set the number of test bytes in DM m+51.

Note: Set X to 1 to specify Antenna 1, and set X to 2 to specify Antenna 2.



CHECK!

DM Area addresses are given in reference to "m," where $m = D20000 + 100 \times \text{Unit number}$.

3. Turn ON the test switch.

Measuring the distance level is started using the method set in the DM Area.



CHECK!

To start Test Mode using the switch on the front of the Unit, set DM m+80 to 0000.
To start Test Mode using bit 15 of CIO n+0, set DM m+80 to 0001.

4. Distance level measurement will begin.

The distance level will be measured, and the communications results will be output to the Processing Results Monitor (CIO n+9) in the Special I/O Unit Area. The measurement results can also be checked on the Amplifier's operation indicators.

Write/Read Speed Level Measurement

A speed level measurement allows for easy checking of the ID Tag's speed of movement and number of usable bytes. This operation measures the number of times that communications can be performed consecutively based on the speed that ID Tags pass through the Antenna communications range and outputs the measurement results to the Processing Results Monitor (CIO n+9) in the Special I/O Unit Area. The measurement results can also be checked on the Amplifier's operation indicators.



The speed level measurement operation simulates writing data. Data is not actually written to the ID Tag.

CHECK!



The speed level measurement will be performed with the contents that was set in advance in DM m+50 and DM m+51.

CHECK!

1. Set the method to use to switch between Run Mode and Test Mode.



To start Test Mode using the switch on the front of the Unit, set DM m+80 to 0000.
To start Test Mode using bit 15 of (CIO n+0), set DM m+80 to 0001.

CHECK!



After setting DM Area data with the Support Software, reset the power supply to the PLC or turn ON the Special I/O Unit Restart Bit. The DM Area settings will be transferred to the ID Sensor Unit when the power supply turns ON or when the Special I/O Unit Restart Bit is turned ON.

CHECK!

2. Set the operation to perform in Test Mode.

Set DM m+50 to B00X (read) or B10X (write), and set the number of test bytes in DM m+51.
Note: Set X to 1 to specify Antenna 1, and set X to 2 to specify Antenna 2.



DM Area addresses are given in reference to "m," where $m = D20000 + 100 \times \text{Unit number}$.

CHECK!

3. Turn ON the test switch.

Measuring the speed level is started using the method set in the DM Area.



To start Test Mode using the switch on the front of the Unit, set DM m+80 to 0000.
To start Test Mode using bit 15 of (CIO n+0), set DM m+80 to 0001.

CHECK!

4. Speed level measurement will begin.

The speed level will be measured, and the communications results will be output to the Processing Results Monitor (CIO n+9) in the Special I/O Unit Area. The measurement results can also be checked on the Amplifier's operation indicators.

■ Noise Level Measurement

A noise level measurement enables checking for spatial noise, noise sources, and the effectiveness of noise countermeasures.

This operation measures the ambient noise level in the installation environment and outputs the measurement results to the Processing Results Monitor (CIO n+9) in the Special I/O Unit Area.



The noise level measurement will be performed with the contents that was set in advance in DM m+50 and DM m+51.

1. Set the method to use to switch between Run Mode and Test Mode.



To start Test Mode using the switch on the front of the Unit, set DM m+80 to 0000.
To start Test Mode using bit 15 of (CIO n+0), set DM m+80 to 0001.



After setting DM Area data with the Support Software, reset the power supply to the PLC or turn ON the Special I/O Unit Restart Bit. The DM Area settings will be transferred to the ID Sensor Unit when the power supply turns ON or when the Special I/O Unit Restart Bit is turned ON.

2. Set the operation to perform in Test Mode.

Set DM m+50 to C00X.

Note: Set X to 1 to specify Antenna 1, and set X to 2 to specify Antenna 2.



DM Area addresses are given in reference to "m," where $m = D20000 + 100 \times \text{Unit number}$.

3. Turn ON the test switch.

Measuring the noise level is started using the method set in the DM Area.



To start Test Mode using the switch on the front of the Unit, set DM m+80 to 0000.
To start Test Mode using bit 15 of (CIO n+0), set DM m+80 to 0001.

4. Noise level measurement will begin.

The noise level will be measured, and the communications results will be output to the Processing Results Monitor (CIO n+9) in the Special I/O Unit Area.

■ Communications Success Rate Measurement

The communications success rate measurement is used to check the communications success rate. The ID Sensor Unit communicates 100 times with a Tag and outputs the measurement results to the Processing Results Monitor (CIO n+9) in the Special I/O Unit Area.



The communications success rate is measured using read operations.



The communications success rate measurement will be performed with the contents that was set in advance in DM m+50.

1. Set the method to use to switch between Run Mode and Test Mode.



To start Test Mode using the switch on the front of the Unit, set DM m+80 to 0000.
To start Test Mode using bit 15 of (CIO n+0), set DM m+80 to 0001.



After setting DM Area data with the Support Software, reset the power supply to the PLC or turn ON the Special I/O Unit Restart Bit. The DM Area settings will be transferred to the ID Sensor Unit when the power supply turns ON or when the Special I/O Unit Restart Bit is turned ON.

2. Set the operation to perform in Test Mode.

Set DM m+50 to C10X and set the number of test bytes in DM m+51.
Note: Set X to 1 to specify Antenna 1, and set X to 2 to specify Antenna 2.



DM Area addresses are given in reference to "m," where $m = D20000 + 100 \times \text{Unit number}$.

3. Turn ON the test switch

Measuring the communications success rate is started using the method set in the DM Area.



To start Test Mode using the switch on the front of the Unit, set DM m+80 to 0000.
To start Test Mode using bit 15 of (CIO n+0), set DM m+80 to 0001.

4. Communications success rate measurement will begin.

The communications success rate will be measured and the measurement results will be output to the Processing Results Monitor (CIO n+9) in the Special I/O Unit Area.

Communications Specifications

There are seven execution sequences that can be used to communicate with the ID Tag. The sequence is specified in the Communications Specification (CIO n+1, bits 04 to 07) in the command settings in the Special I/O Unit Area.

Name	Communications specification	Description
Trigger	0	When the Command Execution Bit turns ON, communications are performed with the ID Tag in the communications area and processing is ended.
Single auto	1	After the Command Execution Bit turns ON, the ID Sensor Unit waits until an ID Tag is detected in the communications area, communications are performed, and processing is ended.
Repeat auto	2	The operation for a single auto specification is repeated. Once communications have been completed with a specific ID Tag, communications will not be performed with it again even if it remains in the communications area. Processing is ended when the Abort Bit is turned ON.
FIFO trigger (See note)	3	When the ID Sensor Unit receives a command, it communicates with an ID Tag and returns a response. After communicating, all further operations with that ID Tag are prohibited. The ID Sensor Unit communicates with only one ID Tag in the communications area. If an ID Tag that has been communicated with for a trigger specification is within the communications area, the ID Sensor Unit will not communicate with it a second time.
FIFO repeat (See note)	4	When the ID Sensor Unit receives a command, it waits until an ID Tag is detected within the communications area, then returns a response. After communicating, all further operations with that ID Tag are prohibited. After returning the response, the ID Sensor Unit again waits for an ID Tag to approach it, and continues repeating the operation until the Abort Bit turns ON.
Multi-access trigger (See note)	5	When the ID Sensor Unit receives a command, it communicates with all ID Tags in the communications area, returns responses in order. After communicating, all further operations with those ID Tags are prohibited. If there are no ID Tags in the communications area, the ID Sensor Unit will return an ID Tag missing error.
Multi-access repeat (See note)	6	When the ID Sensor Unit receives a command, it waits for ID Tags to approach it. It communicates with each Tag in the communications area, and returns responses in order. After communicating, all further operations with those Tags are prohibited. After returning the responses, the ID Sensor Unit again waits for Tags to approach it, and continues repeating the operation until the Abort Bit turns ON.

Note: FIFO trigger, FIFO repeat, Multi-access trigger, and Multi-access repeat specification cannot be used for communicating with V680-D1KP□□ Tags.

Trigger

When a trigger is specified, communications are performed with the ID Tag when the Command Execution Bit (CIO n, bit 0) in the Special I/O Unit Area turns ON and command execution is ended when communications have been completed. If there is no ID Tag in the communications area when the Command Execution Bit turns ON, ID Tag Missing Error Flag (CIO n+8, bit 10) in the Results Information in the Special I/O Unit Area will turn ON and an error code (E072) will be stored in the Processing Results Monitor (CIO n+9). Use a sensor or other method to detect the presence of an ID Tag before turning ON the Command Execution Bit.

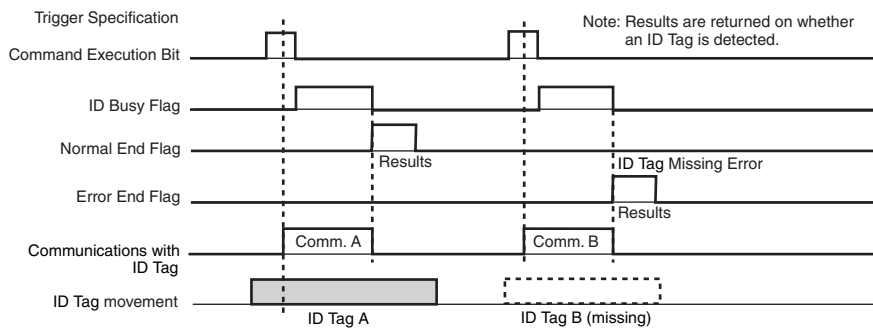
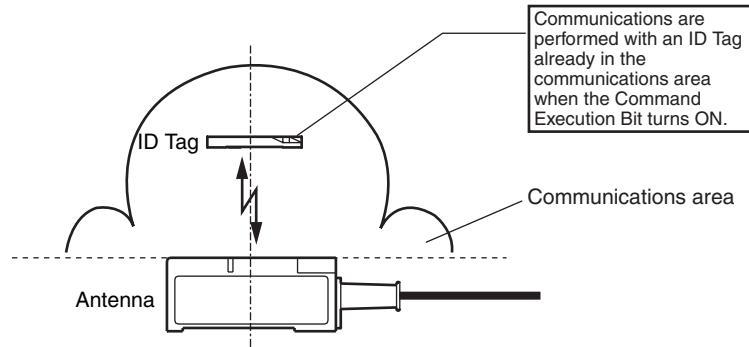

Single Auto

With a single auto specification, the presence of an ID Tag is automatically detected, and communications are performed, eliminating the need for detecting the ID Tag as is required for a trigger specification. Command execution is ended as soon as communications are completed with one ID Tag. Execution can also be ended by turning ON the Abort Bit (CIO n, bit 02) while the ID Sensor Unit is waiting for the ID Tag.

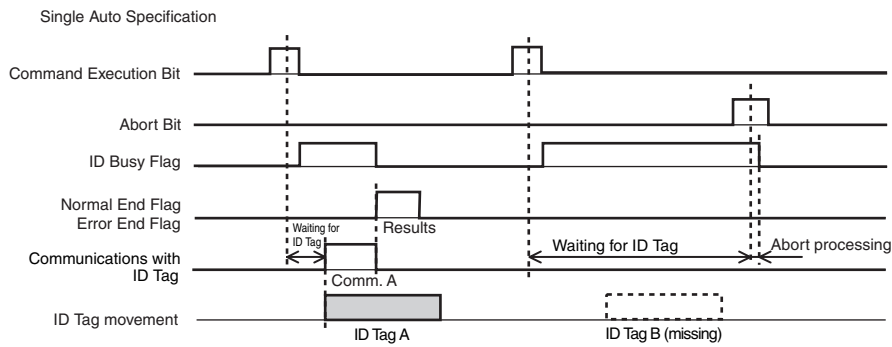
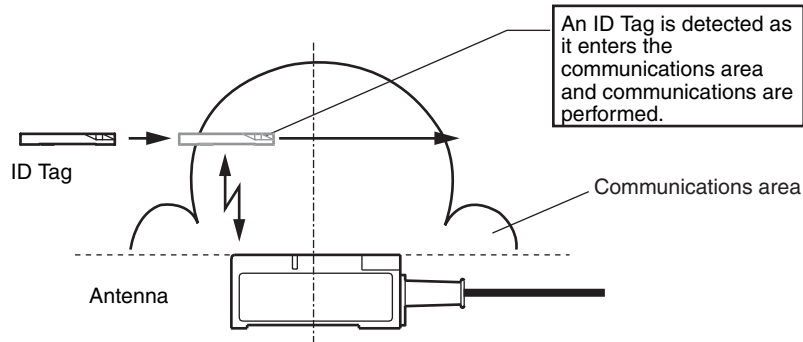

Repeat Auto

With a repeat auto specification, the presence of an ID Tag is automatically detected, and communications are performed, eliminating the need for detecting the ID Tag as is required for a trigger specification. As opposed to a single auto specification, command execution is not ended when communications with the first ID Tag have been completed, rather the ID Sensor Unit waits for the next ID Tag. Once communications have been completed with a specific ID Tag, communications will not be performed with it again even if it remains in the communications area. Repeat Auto execution can also be ended by turning ON the Abort Bit (CIO n, bit 02).

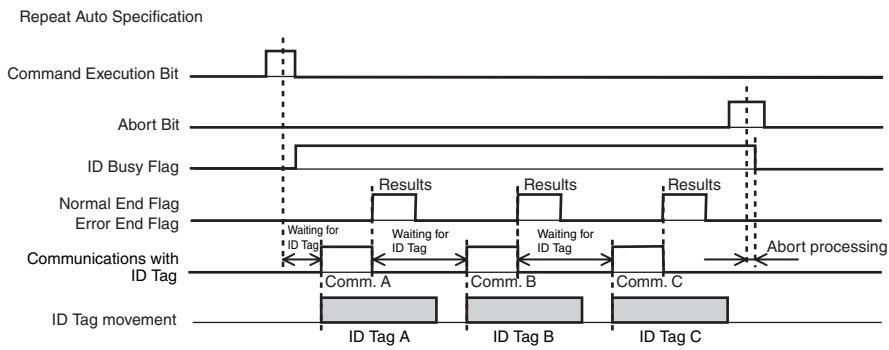
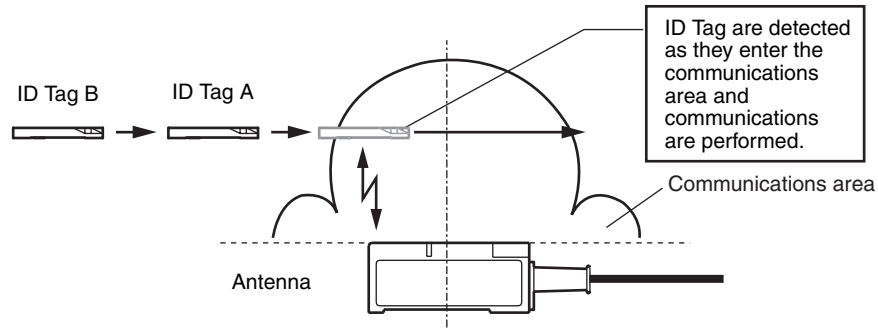

FIFO Trigger

With a FIFO trigger communications specification, communications are executed with an ID Tag when a command is sent. After communicating, the ID Sensor Unit returns a response. Operations are prohibited for ID Tags that have completed communications until they leave the communications area. After the ID Sensor Unit sends a response, it will wait for the next command. If there is no Tag in the communications area when the ID Sensor Unit receives the command from the CPU Unit, the ID Sensor Unit will return an ID Tag missing error.

With the FIFO trigger communications specification, even if there are ID Tags in the communications area that have completed communications, the ID Sensor Unit can still communicate with the next ID Tag. (Commands will be accepted for an Antenna that is not processing a command.)

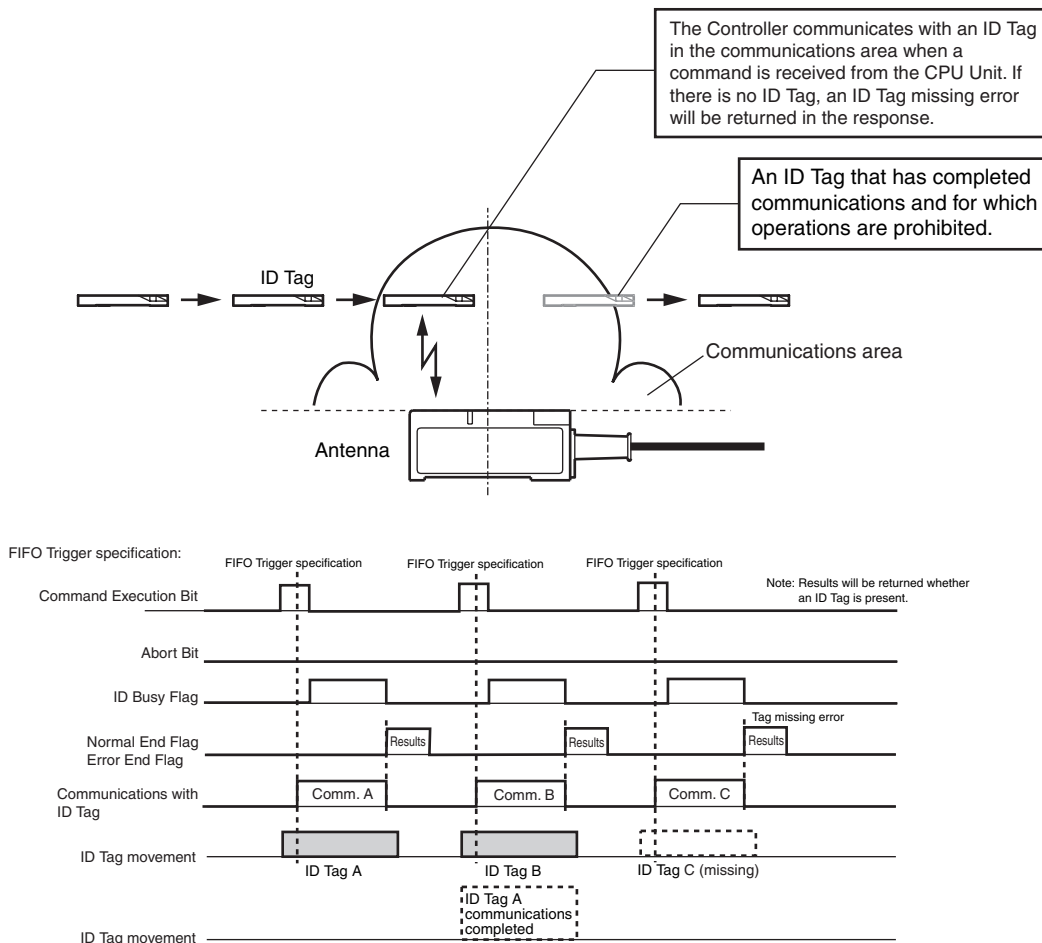

To communicate with ID Tags in the communications area that have completed communications, turn ON the Abort Bit in the Special I/O Unit Area (CIO n, bit 02) to cancel processing.

CHECK!



When using the V680-D2KF□□/□-D□KF68 with a FIFO trigger specification, the normal communications speed will be used regardless of the setting in DM m+0.

CHECK!



FIFO trigger specification cannot be used for communicating with V680-D1KP□□ Tags.

CHECK!

FIFO Repeat

With a FIFO repeat communications specification, the ID Sensor Unit automatically detects ID Tags that enter the communications area after a command is sent and communicates with them repeatedly. Operations are prohibited for ID Tags that have completed communications until they leave the communications area. After communicating, the ID Sensor Unit returns a response. ID Sensor Unit processing ends when the Abort Bit is turned ON. The ID Sensor Unit will wait for the next command. With the FIFO repeat communications specification, even if there are ID Tags in the communications area that have completed communications, the ID Sensor Unit can still communicate with the next ID Tag. (Commands will be accepted for an Antenna that is not processing a command.)

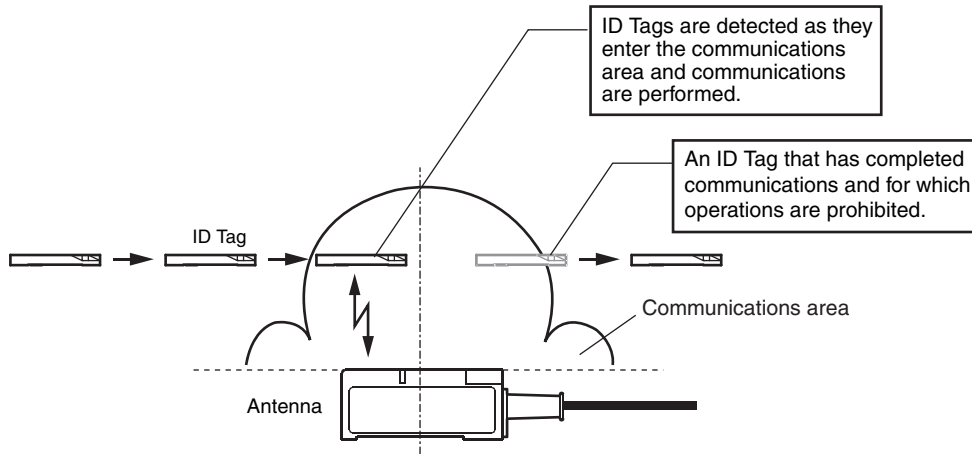

FIFO Repeat Specification:

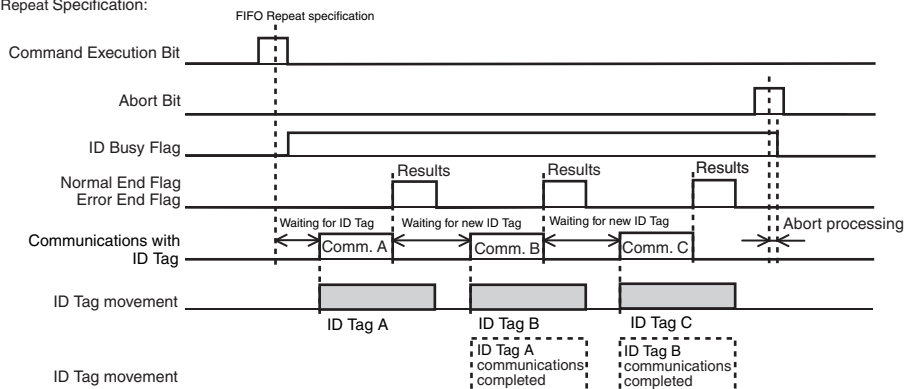

CHECK!

When using the V680-D2KF□□/-D□KF68 with a FIFO repeat specification, the normal communications speed will be used regardless of the setting in DM m+0.



CHECK!

FIFO repeat specification cannot be used for communicating with V680-D1KP□□ Tags.

Multi-access Trigger

With a multi-access trigger communications specification, communications are executed with multiple ID Tags when a command is sent. The ID Sensor Unit sends responses sequentially as communications with the ID Tags in the communications area are completed. Move the results data stored in the Data Storage Area to another area before the results data from the next ID Tag is stored. After the ID Sensor Unit has completed communications with all of the ID Tags in the communications area, the ID Busy Flag will turn OFF, and the ID Sensor Unit will wait for the next command. (Commands will be accepted for an Antenna that is not processing a command.)

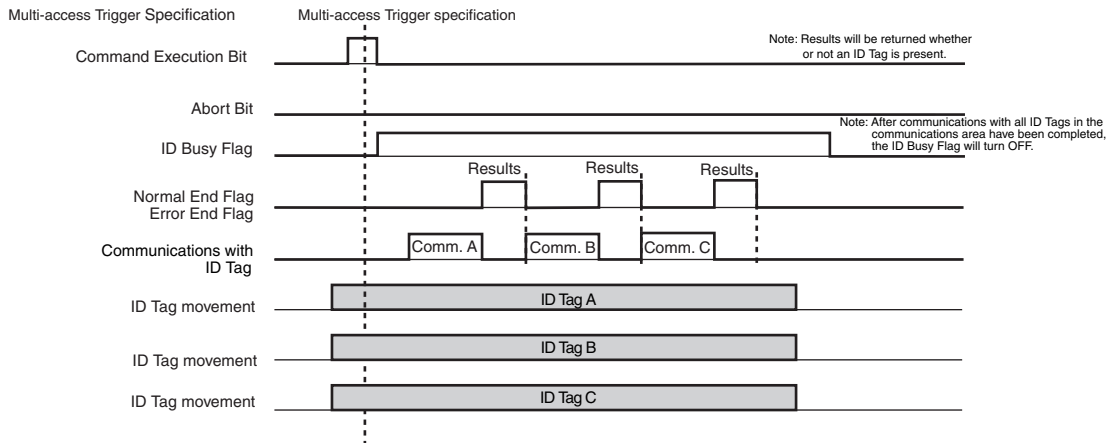
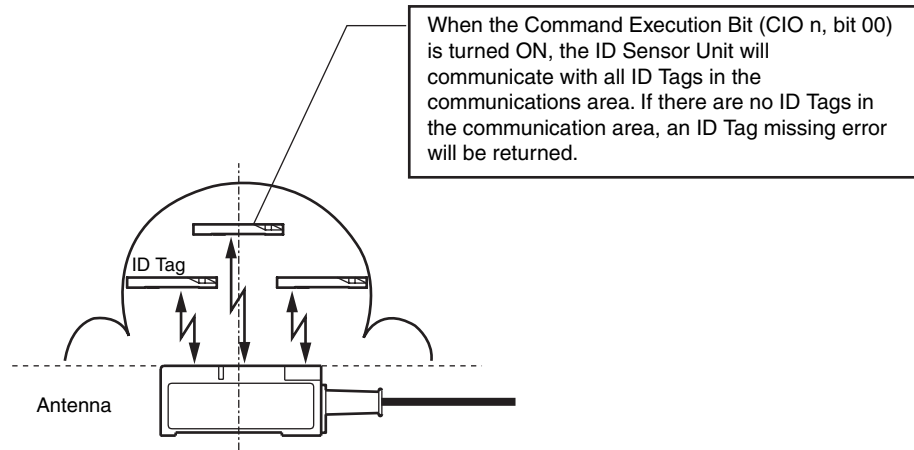

CHECK!

When using the V680-D2KF□□/D□KF68 with a multiple-access trigger specification, the normal communications speed will be used regardless of the setting in DM m+0.



CHECK!

Multi-access trigger specification cannot be used for communicating with V680-D1KP□□ Tags.

Multi-access Repeat

With a multi-repeat communications specification, the ID Sensor Unit automatically detects multiple ID Tags that enter the communications area and communicates with them repeatedly when a command is sent. The ID Sensor Unit sends responses sequentially as communications with the ID Tags in the communications area are completed. Move the results data stored in the data storage area to another area before the results data from the next ID Tag is stored. Even after the ID Sensor Unit has sent the responses, the ID Sensor Unit continues to automatically detect ID Tags that enter the communications area and communicates with them repeatedly. Operations are prohibited for ID Tags that have completed communications until they leave the communications area. ID Sensor Unit processing ends when the Abort Bit is turned ON. The ID Sensor Unit will wait for the next command. (Commands will be accepted for an Antenna that is not processing a command.)

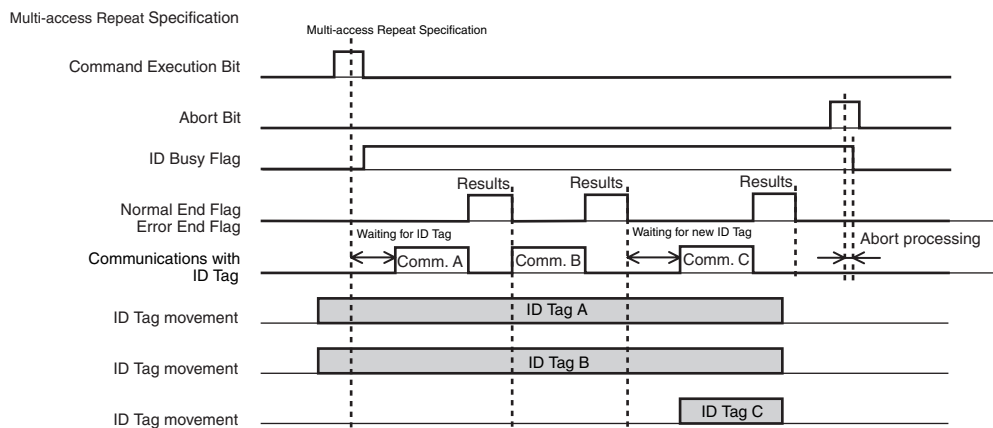
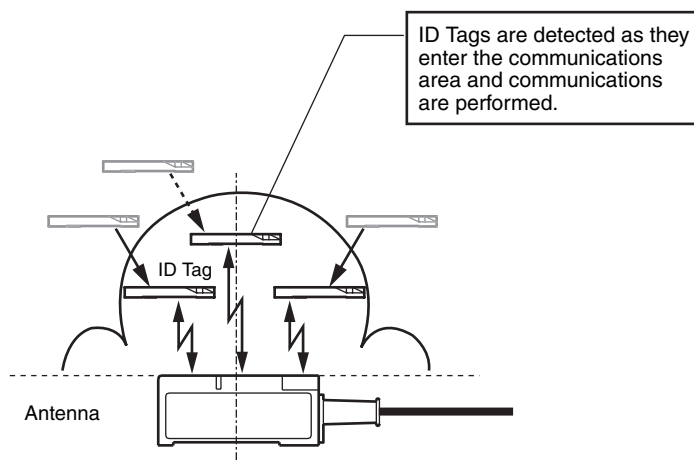

When using the V680-D2KF□□/□□-D□□KF68 with a multi-access repeat specification, the normal communications speed will be used regardless of the setting in DM m+0.



Multi-access repeat specification cannot be used for communicating with V680-D1KP□□ Tags.

Parameter Settings in DM Area

The following parameter settings can be adjusted to the user application to optimize the performance and reliability of the ID Sensor Unit.

- System Settings
- Auto Wait Time Setting
- Write Protection Disable Setting
- Antenna Connection Setting
- Results Monitor Output Setting
- Test Settings
- Run/Test Switching Method Setting

Although the default settings can be used for most applications without any problems, the parameters can be changed to optimize the system.

System Settings

■ UID Addition Setting

These settings are used to set whether or not a UID will be added to the read command response.

DM Area address		Bit No.	Description	Default	
Antenna 1 of CS1W-V680C11, CS1W-V680C12, CJ1W-V680C11, or CJ1W-V680C12	Antenna 2 of CS1W-V680C12 or CJ1W-V680C12				
m	m+100	12 to 15	0	UID not added	0 (Not added)
			1	UID added	

Note: If adding the UID is specified, the UID (8 bytes) will be appended to the front of the read response data.



CHECK!

If using Intelligent I/O Instructions is specified as the data transfer method, set the IORD service control information area address information in D00004 to D00007 to 1. The first four words of data will be the UID data.

■ Test Mode Disable Setting

This setting can be used to disable entering Test Mode using the test switch on the front panel of the ID Sensor Unit. The test switch can be disabled to prevent accidentally entering Test Mode.

DM Area address		Bit No.	Description	Default	
Antenna 1 of CS1W-V680C11, CS1W-V680C12, CJ1W-V680C11, or CJ1W-V680C12	Antenna 2 of CS1W-V680C12 or CJ1W-V680C12				
m	m+100	08 to 11	0	Test switch enabled.	0 (Enabled)
			1	Test switch disabled (always Run Mode).	

■ Verification Setting

Verification can be enabled for write operations, or verification can be disabled to shorten the communications time. The verification setting is valid for all commands except for Read and Data Check with a processing specification of verification.

DM Area address		Bit No.	Description	Default
Antenna 1 of CS1W-V680C11, CS1W-V680C12, CJ1W-V680C11, or CJ1W-V680C12	Antenna 2 of CS1W-V680C12 or CJ1W-V680C12			
m	m+100	04 to 07	0 Verify write operations.	0 (Verification)
			1 Do not verify write operations.	

■ Communications Speed Setting

High-speed communications can be set whenever the communications method is set to trigger, single auto, or repeat auto.

DM Area address		Bit No.	Description	Default
Antenna 1 of CS1W-V680C11, CS1W-V680C12, CJ1W-V680C11, or CJ1W-V680C12	Antenna 2 of CS1W-V680C12 or CJ1W-V680C12			
m	m+100	00 to 03	0 Communications speed setting: Normal	0 (normal)
			1 Communications speed setting: High speed	



- First word allocated to Unit in DM Area: $m = D20000 + 100 \times \text{Unit number}$



After setting DM Area data with the Support Software, reset the power supply to the PLC or turn ON the Special I/O Unit Restart Bit. The DM Area settings will be transferred to the ID Sensor Unit when the power supply turns ON or when the Special I/O Unit Restart Bit is turned ON.

Auto Wait Time Setting

If a normal response is not received in communications with an ID Tag when the ID Tag has been detected, retry processing will be performed to resend the same command. Retry processing is performed until the Auto Wait Time has expired while the ID Sensor Unit is waiting for an ID Tag. The ID Tag wait status begins for a single auto specification, when command execution is started. From the second ID Tag for a repeat auto specification, it begins when communications with the previous ID Tag have been completed.

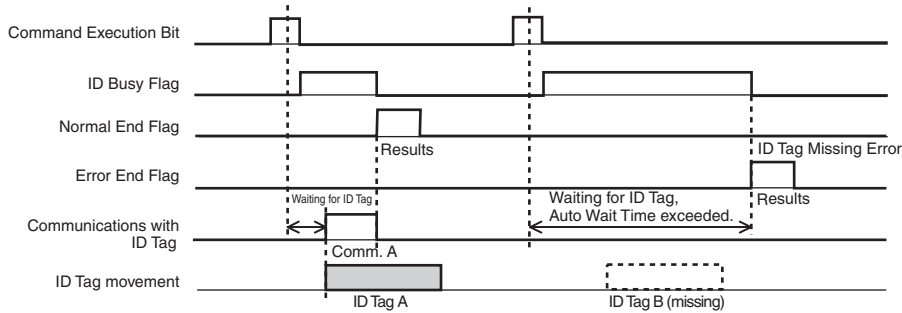

DM Area address		Bit No.	Type	Description	Default
Antenna 1 of CS1W-V680C11, CS1W-V680C12, CJ1W-V680C11, or CJ1W-V680C12	Antenna 2 of CS1W-V680C12 or CJ1W-V680C12				
m+1	m+101	00 to 15	0000 to 9999	1 to 9999 × 0.1 s 0: Infinite (Time not monitored)	0 (Infinite)



CHECK!

- First word allocated to Unit in DM Area: $m = D20000 + 100 \times \text{Unit number}$



CHECK!

- After setting DM Area data with the Support Software, reset the power supply to the PLC or turn ON the Special I/O Unit Restart Bit. The DM Area settings will be transferred to the ID Sensor Unit when the power supply turns ON or when the Special I/O Unit Restart Bit is turned ON.

Write Protection Disable Setting

The write protection disable setting can be used to disable the write protection settings in ID Tags.

DM Area address		Bit No.	Description	Default	
Antenna 1 of CS1W-V680C11, CS1W-V680C12, CJ1W-V680C11, or CJ1W-V680C12	Antenna 2 of CS1W-V680C12 or CJ1W-V680C12				
m+2	m+102	00 to 07	00	Write protection enabled using V680 method	00 (Write protection enabled using V680 method)
			01	Write protection disabled.	
			02	Write protection enabled using V600 method	



CHECK!

- First word allocated to Unit in DM Area: $m = D20000 + 100 \times \text{Unit number}$



CHECK!

- After setting DM Area data with the Support Software, reset the power supply to the PLC or turn ON the Special I/O Unit Restart Bit. The DM Area settings will be transferred to the ID Sensor Unit when the power supply turns ON or when the Special I/O Unit Restart Bit is turned ON.

Antenna Connection Setting

The Antenna connection setting can be used to set whether or not a V680-H01 Antenna is connected to the ID Sensor Unit.

DM Area address		Bit No.	Description	Default
Antenna 1 of CS1W-V680C11, CS1W-V680C12, CJ1W-V680C11, or CJ1W-V680C12	Antenna 2 of CS1W-V680C12 or CJ1W-V680C12			
m+3	m+103	00 to 03	0 Standard Antenna connected.	0 (Standard)
			1 V680-H01 Antenna connected.	



First word allocated to Unit in DM Area: $m = D20000 + 100 \times \text{Unit number}$

CHECK!



After setting DM Area data with the Support Software, reset the power supply to the PLC or turn ON the Special I/O Unit Restart Bit. The DM Area settings will be transferred to the ID Sensor Unit when the power supply turns ON or when the Special I/O Unit Restart Bit is turned ON.

CHECK!



The V680-H01 Antenna can be connected to only a One-channel ID Sensor Unit. It cannot be connected to a Two-channels ID Sensor Unit.

CHECK!

Results Monitor Output Setting

DM Area address		Bit No.	Description	Default
Antenna 1 of CS1W-V680C11, CS1W-V680C12, CJ1W-V680C11, or CJ1W-V680C12	Antenna 2 of CS1W-V680C12 or CJ1W-V680C12			
m+4	m+104	00 to 03	0 Communications time	0 (communi- cations time)
			1 Noise level	



First word allocated to Unit in DM Area: $m = D20000 + 100 \times \text{Unit number}$

CHECK!



After setting DM Area data with the Support Software, reset the power supply to the PLC or turn ON the Special I/O Unit Restart Bit. The DM Area settings will be transferred to the ID Sensor Unit when the power supply turns ON or when the Special I/O Unit Restart Bit is turned ON.

CHECK!

Test Settings

The test settings are used to set the operation, Antenna, and number of test bytes used in Test Mode.

DM Area address	Bit No.	Type	Description	Setting value
m+50	08 to 15	Test Settings (Both Antennas 1 and 2)	Test Operation	00: Communications test A0: Distance level B0: Read speed level B1: Write speed level C0: Noise level C1: Communications success rate
	00 to 07		Test Antenna	01: Antenna 1 02: Antenna 2
m+51	00 to 15		Number of Test Bytes	0000 to 0800 hex (bytes)



CHECK!

First word allocated to Unit in DM Area: $m = D20000 + 100 \times \text{Unit number}$

Run/Test Switching Method Setting

You can switch between Run Mode and Test Mode by using the test switch or by using bit 15 of CIO n+0.

DM Area address	Bit No.	Type	Description	Set value
m+80	00 to 03	Run/Test Switching Method Setting (Both Antennas 1 and 2)	Run/Test Switching Method Setting	1: CPU Unit 0: Test switch



CHECK!

First word allocated to Unit in DM Area: $m = D20000 + 100 \times \text{Unit number}$



CHECK!

After setting DM Area data with the Support Software, reset the power supply to the PLC or turn ON the Special I/O Unit Restart Bit. The DM Area settings will be transferred to the ID Sensor Unit when the power supply turns ON or when the Special I/O Unit Restart Bit is turned ON.

Tag Memory Setting

This setting can be used to set the ID Tag memory map to the map that is used with ID Controllers for Heat-resistant RFID Systems (V680-CA1D/-CA2D).

DM Area address	Bit No.	Type	Description	Set value
m+81	00 to 03	Tag Memory Setting (Both Antennas 1 and 2)	Tag Memory Setting	1: CA1D Mode 0: Standard Mode

Data Transfer Setting

The data transfer method for the Read, Write, Read with Error Correction, and Write with Error Correction command can be set to cyclic transfer or to the IORD/IOWR instructions.

Cyclic data transfers will be used for all other commands regardless of the setting of the data transfer method. If the IORD/IOWR instructions are executed to transfer data when cyclic data transfer is specified, data will not be transferred and an error will occur.

DM Area address	Bit No.	Type	Description	Set value
m+90	00 to 03	Data Transfer Setting (Both Antennas 1 and 2)	Data Transfer Setting	0: Use cyclic transfer 0: Use Intelligent I/O Instructions



CHECK!

First word allocated to Unit in DM Area: $m = D20000 + 100 \times \text{Unit number}$.



CHECK!

After setting word m+90 in the DM Area with the Support Software, reset the power supply to the PLC or turn ON the Special I/O Unit Restart Bit. The setting in m+90 in the DM Area will be transferred to the ID Sensor Unit when the power supply turns ON or when the Special I/O Unit Restart Bit is turned ON.

ID Tag Memory

The memory access area for the ID Sensor Unit is 64 Kbytes from addresses 0000 to FFFF (hex). The area that can actually be accessed is determined by the memory capacity of the ID Tag.

■ V680-D1KP□□ ID Tags

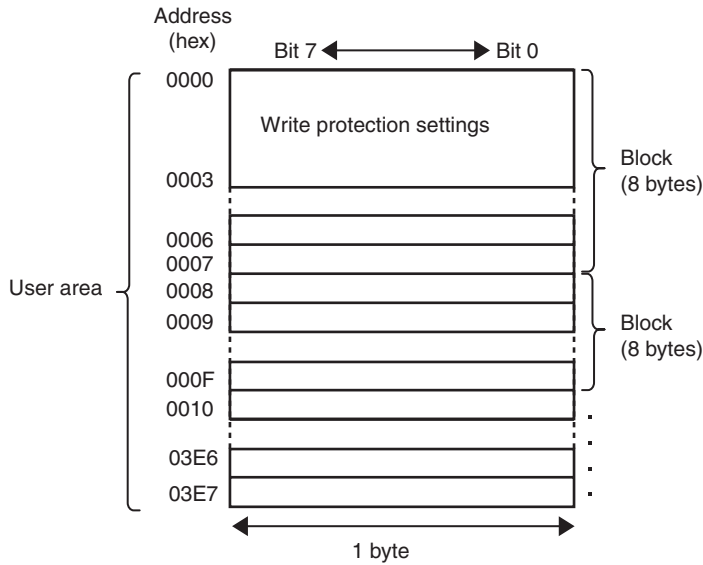

■ V680-D2KF□□ ID Tags

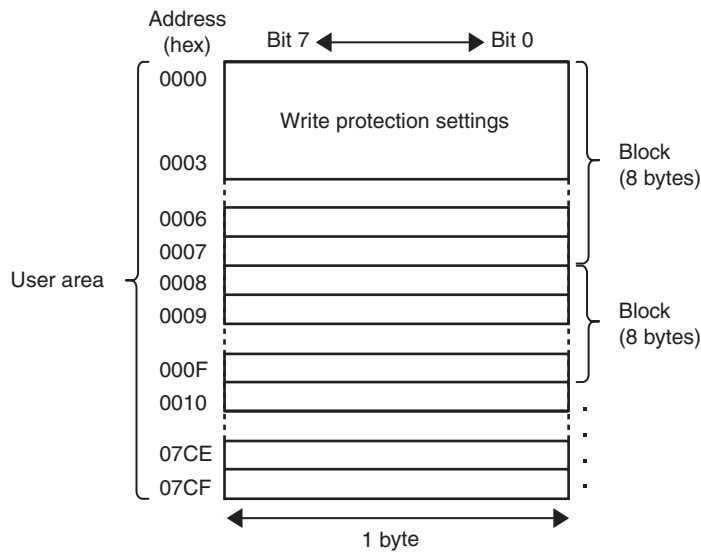

■ V680-D8KF□□ ID Tags

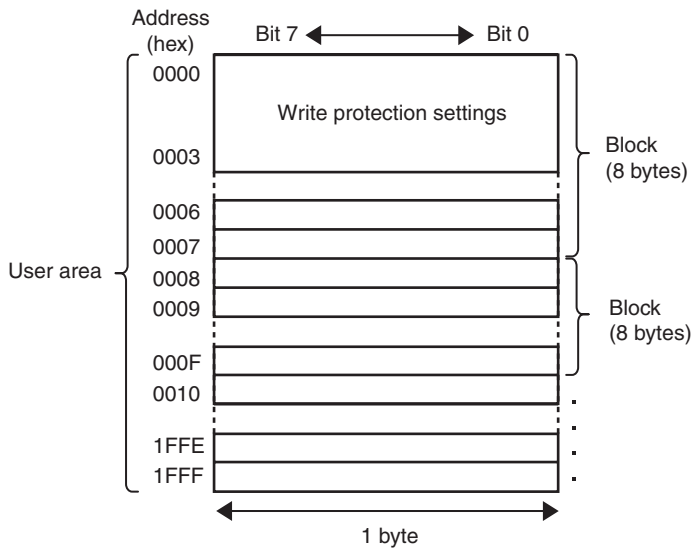

■ V680-D32KF68 ID Tags

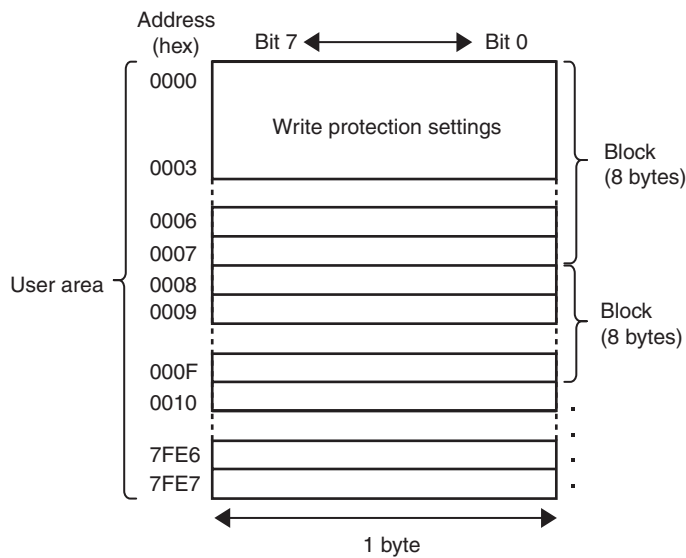

Write Protection

The write protection function is provided so that product model numbers and other important product information stored in the ID Tags can be protected from being lost through careless write operations. We recommend that write protection be set after important data has been written.



Either of two write protection methods can be used, the V680 method or the V600 method. The method can be changed by setting DM m+2 (Write Protection Disable Setting). Normally use the V680 method. If a V600 system is replaced with the V680, the V600 method can be used to enable using the current ID Tag memory map, eliminating the need to change system programming.

Setting Write Protection Using the V680 Method

Write protection is set in four bytes of ID Tag addresses 0000 to 0003 (hex). The setting for the most significant bit of address 0000 (hex) specifies whether or not write protection is enabled for the ID Tag.

Write Protection Setting Area in ID Tag Memory Map

Address (hex)	7	6	5	4	3	2	1	0
0000	Enable/Disable Bit	Upper two digits of start address (00 to 7F)						
0001	Lower two digits of start address (00 to FF)							
0002	Upper two digits of end address (00 to FF)							
0003	Lower two digits of end address (00 to FF)							

- The most significant bit of address 0000 (hex) is the Write-protect Bit.
ON: Enable write protection
OFF: Disable write protection
- Write Protection Setting Ranges
Start address: 0000 to 7FFF hex
End address: 0000 to FFFF hex



If write protection is enabled, write separately to the write protection setting area (addresses 0000 to 0003 hex) and the rest of the ID Tag (addresses 0004 hex and higher). If the MSB of address 0000 hex is ON and you write both the write protection setting area (addresses 0000 to 0003 hex) and following addresses at the same time, a write protection error will occur.



If write protection is disabled, you can use the write protection setting area (addresses 0000 to 0003 hex) as normal user memory. If you use the write protection setting area (addresses 0000 to 0003 hex) as normal user memory, be sure to disable write protection in the ID Sensor Unit.

• Write Protection Setting Example

Start Address Lower Than End Address

All addresses from the start address to the end address, inclusive, will be write-protected.

Address (hex)	Upper digit				Lower digit			
0000	1	0	0	0	0	0	0	0
	8				0			
0001	0	0	0	1	0	1	0	1
	1				5			
0002	0	0	0	0	0	0	0	1
	0				1			
0003	0	0	1	0	0	0	0	0
	2				0			

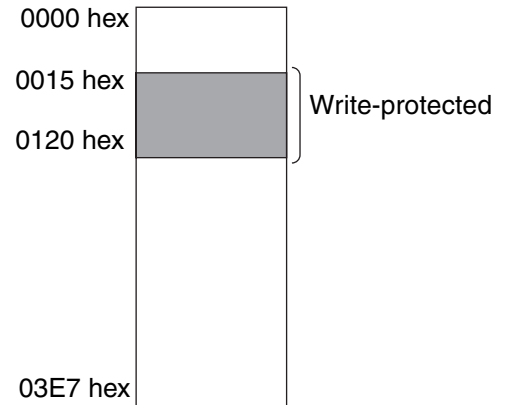

Start Address Equals End Address

Only the set address (1 byte) will be write-protected.

Address (hex)	Upper digit				Lower digit			
0000	1	0	0	0	0	0	0	1
	8				1			
0001	0	0	1	0	0	0	0	0
	2				0			
0002	0	0	0	0	0	0	0	1
	0				1			
0003	0	0	1	0	0	0	0	0
	2				0			

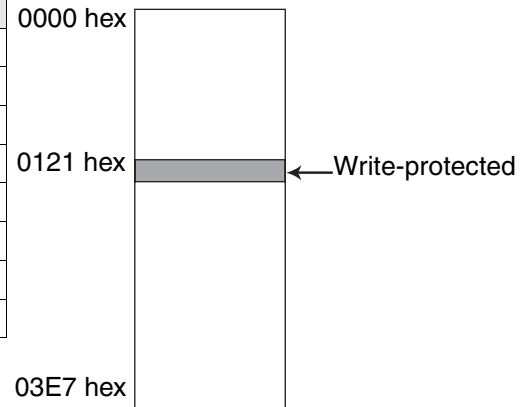

End Address Exceeds Last ID Tag Address

All addresses from the start address to the final address in the ID Tag, inclusive, will be write-protected.

Address (hex)	Upper digit				Lower digit			
0000	1	0	0	0	0	0	1	1
	8				3			
0001	0	0	0	0	0	0	0	0
	0				0			
0002	0	0	0	0	0	0	1	1
	0				3			
0003	1	1	1	1	1	1	1	1
	F				F			

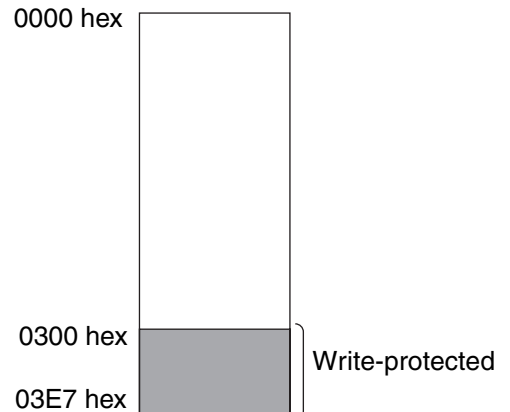

The write protection setting area in the ID Tag is not write-protected.

Start Address Greater Than End Address

All addresses from the start address to the final address and all addresses from address 0004 hex to the end address in the ID Tag, inclusive, will be write-protected.

Address (hex)	Upper digit				Lower digit			
	1	0	0	0	0	0	0	1
0000	8				1			
	0	0	1	0	0	0	0	0
0001	2				0			
	0	0	0	0	0	0	0	0
0002	0				0			
	0	0	0	1	0	1	0	1
0003	1				5			

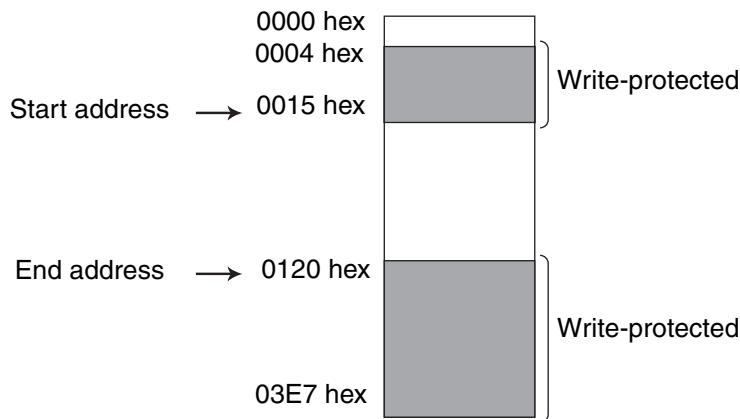

The write protection setting area in the ID Tag is not write-protected.

CHECK!

Clearing Write Protection Using the V680 Method

To temporarily clear write protection, e.g., to overwrite the write-protected data, turn OFF the MSB of address 0000 hex in the ID Tag.



Application Precaution for Write Protection

Write protection is implemented by the ID Sensor Unit. It will not be effective for Reader Writers from other companies.

CHECK!

Setting Write Protection Using the V600 Method

With the V600 Series, different write protection setting methods are used for EEPROM Data Carriers (V600-D23P□□) (without batteries) and SRAM Data Carriers (with batteries). When using V600 commands with the V680-series ID Sensor Unit, the data memory setting in the ID Sensor Unit and the type of ID Tags can be selected to enable using the previous write protection setting method.

- Using EEPROM ID Tags (V680-D1KP□□)
V600 EEPROM Write Protection Method
- Using FRAM ID Tags (V680-D2K/8K/32KF□□)
V600 SRAM Write Protection Method



The ID Sensor Unit will automatically switch between the V600 EEPROM write protection method and the V600 SRAM write protection method. No user setting is required.

CHECK!

■ V600 EEPROM Write Protection Method

(The following information applies when the V600 write protection method is set and V680-D1KP□□ ID Tags are used.)

Write protection is set by writing the end address to be protected in address 0000 hex of the ID Tag. The area between address 0001 hex and the end address will be write-protected. The status of the most significant bit of address 0000 hex determines whether write protection is enabled.

Therefore, addresses 0080 to 03E7 hex cannot be set as the end address.

If the end address is set to 00 hex, however, all addresses from 0001 to 03E7 hex will be protected.

Memory Map of Write Protection Setting Area for V600 EEPROM Write Protection Method

Address (hex)	7	6	5	4	3	2	1	0
0000	Enable/ Disable Bit	End address						

- Setting of MSB of Address 0000 Hex
ON: Write protection enabled
OFF: Write protection disabled
- End Address Setting Range
End address: 00 or 01 to 7F hex



If write protection is enabled, write separately to the write protection setting area (address 0000 hex) and the rest of the ID Tag (addresses 0001 hex and higher). If the MSB of address 0000 hex is ON and you write both the write protection setting area (address 0000 hex) and following addresses at the same time, a write protection error will occur.

CHECK!

Write Protection Setting Examples

The following settings would write-protect addresses 0001 through 0012 hex:

Address (hex)	Upper digit				Lower digit			
0000	1	0	0	0	0	0	0	0
	8				0			

End Address Set to 00 Hex

The entire memory except address 0000 hex is write-protected by setting the end address to 00 hex, as shown below.

Address (hex)	Upper digit				Lower digit			
0000	1	0	0	0	0	0	0	0
	8				0			

 The write protection setting area in the ID Tag is not write-protected.
CHECK!

■ **V600 SRAM Write Protection Method**

(The following information applies when the V600 write protection method is set and V680-D2K/8K/32KF□□ ID Tags are used.)

Write protection is set by writing the start address and the end address to be protected in addresses 0002 to 0005 hex of the ID Tag. The area between the start address and the end address will be write-protected. The status of the most significant bit of address 0002 hex determines whether write protection is enabled.

If the V600 SRAM write protection method is being used and write protection is enabled in the ID Sensor Unit, addresses 0000 and 0001 hex will always be write-protected (regardless of the write protection enable/disable setting in the ID Tag).

Memory Map of Write Protection Setting Area for V600 EEPROM Write Protection Method

Address (hex)	7	6	5	4	3	2	1	0
0002	Enable/Disable Bit	Upper two digits of start address (00 to 7F hex)						
0003	Lower two digits of start address (00 to FF hex)							
0004	Upper two digits of end address (00 to FF hex)							
0005	Lower two digits of end address (00 to FF hex)							

- Setting of MSB of Address 0002 Hex
ON: Write protection enabled
OFF: Write protection disabled
- Range in ID Tag for Which Write Protection Can Be Set
Start address: 0006 to 7FFF hex
End address: 0006 to FFFF hex

 If write protection is enabled, write separately to the write protection setting area (addresses 0002 to 0005 hex) and the rest of the ID Tag (addresses 0006 hex and higher). If the MSB of address 0002 hex is ON and you write both the write protection setting area (addresses 0002 to 0005 hex) and following addresses at the same time, a write protection error will occur.
CHECK!

• ID Tag Write Protection Setting Examples

Start Address Lower Than End Address

All addresses from the start address to the end address, inclusive, will be write-protected.

Address (hex)	Upper digit				Lower digit			
0000	1	0	0	0	0	0	0	0
	8				0			
0001	0	0	0	1	0	1	0	1
	1				5			
0002	0	0	0	0	0	0	0	1
	0				1			
0003	0	0	1	0	0	0	0	0
	2				0			

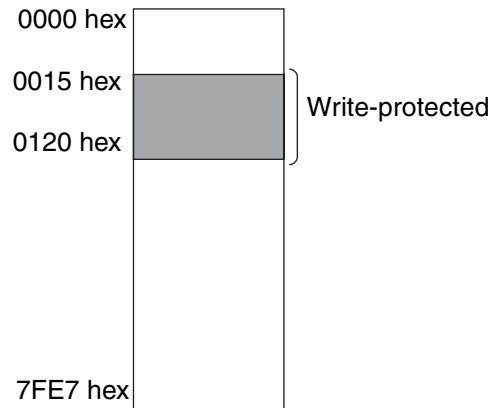

Start Address Equals End Address

Only the set address (1 byte) will be write-protected.

Address (hex)	Upper digit				Lower digit			
0000	1	0	0	0	0	0	0	0
	8				0			
0001	0	0	1	0	0	0	0	1
	2				1			
0002	0	0	0	0	0	0	0	0
	0				0			
0003	0	0	1	0	0	0	0	1
	2				1			

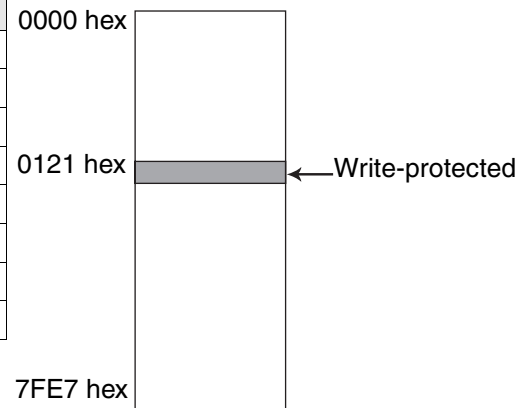

End Address Exceeds Last ID Tag Address

All addresses from the start address to the final address in the ID Tag, inclusive, will be write-protected.

Address (hex)	Upper digit				Lower digit			
0000	1	0	0	0	0	0	1	1
	8				3			
0001	0	0	0	0	0	0	0	0
	0				0			
0002	1	1	1	1	1	1	1	1
	F				F			
0003	1	1	1	1	1	1	1	1
	F				F			

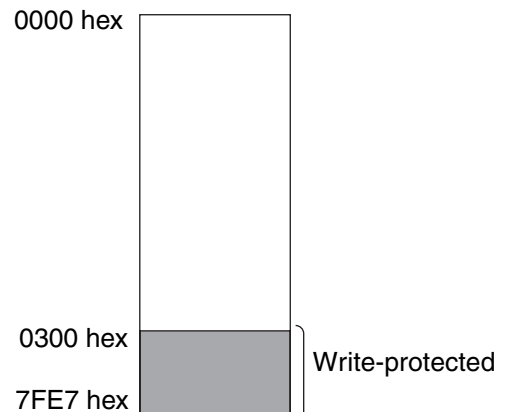

The write protection setting area in the ID Tag is not write-protected. Addresses 0000 and 0001 hex will always be write-protected (regardless of the write protection enable/disable setting in the ID Tag).

Start Address Greater Than End Address

All addresses from the start address to the final address and all addresses from address 0006 hex to the end address in the ID Tag, inclusive, will be write-protected.

Address (hex)	Upper digit				Lower digit			
0002	1	0	0	0	0	0	0	1
	8				1			
0003	0	0	1	0	0	0	0	0
	2				0			
0004	0	0	0	0	0	0	0	0
	0				0			
0005	0	0	0	1	0	1	0	1
	1				5			

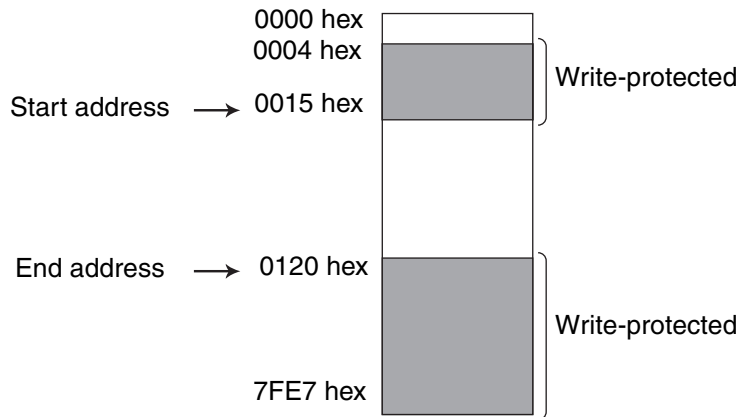

CHECK!

The write protection setting area in the ID Tag is not write-protected. Addresses 0000 and 0001 hex will always be write-protected (regardless of the write protection enable/disable setting in the ID Tag).

Clearing Write Protection Using the V600 Method

To temporarily clear write protection, e.g., to overwrite the write-protected data, turn OFF the MSB of the following address in the ID Tag.

- V600 EEPROM write protection method: 0000 hex
- V600 SRAM write protection method: 0002 hex
- V680 write protection method: 0000 hex



CHECK!

Application Precaution for Write Protection
Write protection is implemented by the ID Sensor Unit. It will not be effective for Reader Writers from other companies.

ID Tag Service Life Check

The Number of Writes Control command can be used to determine whether the ID Tag write limit has been exceeded. Detecting when the write life has been exceeded for an ID Tag is performed by using the Number of Writes Control command that determines whether the write count (100,000 times or a user specified value) for an ID Tag has been exceeded.

There are two ways to manage the number of writes. One is to add to the number of writes and then detect when the total exceeds 100,000 writes. The other is to subtract from a user-specified number of writes and then detect whether the write count has been exceeded.

■ Number of Writes Control 1 (Life Control = Preset Number of Writes)

The Number of Writes Control Area consists of 3 bytes from the start address. The Number of Writes Control command is executed with an Add specification. The specified numbers of writes are added and the total is written to the control area. When the value in the number of writes control area exceeds the preset number of writes (100,000 writes) (0186A0 hex), the Status Flag (CIO n+8, bit 04) in the Results Information turns ON. If the value in the control area already exceeds 100,000 writes, the value will not be changed.

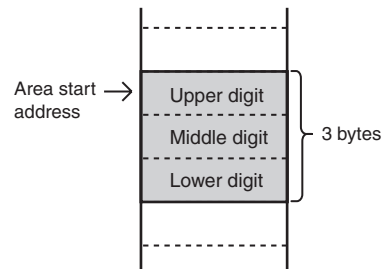

• Application Method

The life of the ID Tag can be managed by updating the number of writes value when data is written to the address most frequently written. (The life of EEPROM ID Tags is 100,000 writes for any one data block (8 bytes), so the number of writes must be counted for the address that is written most frequently.) It is also possible to confirm the number of writes without updating the number of writes value.

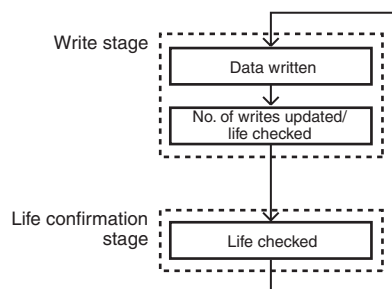

• **Application Example**

The following example uses 3 bytes starting at address 0010 (hex) as the number of writes control area.

1) A Write command is executed to clear the control area.

Address (hex)	Bit 7	Bit 0
000F		
0010	0	0
0011	0	0
0012	0	0
0013		

2) The Number of Writes Control command is executed with an Add specification and the number of writes set to 4.

Address (hex)	Bit 7	Bit 0
000F		
0010	0	0
0011	0	0
0012	0	4
0013		

3) The Number of Writes Control command is executed with an Add specification and the number of writes set to 5.

Address (hex)	Bit 7	Bit 0
000F		
0010	0	0
0011	0	0
0012	0	9
0013		

4) The following illustration shows memory status when the total number of writes has reached 100,000 writes. If the Number of Writes Control command is executed with an Add specification and the number of writes set to 5, the Status Flag (CIO n+8, bit 04) in the Results Information will turn ON.

Address (hex)	Bit 7	Bit 0
000F		
0010	0	1
0011	8	6
0012	A	0
0013		



For any one ID Tag, use only an Add specification or a Subtract specification for the Number of Writes Control command. If both specifications are used for the same ID Tag, the number of writes control will not be possible.

■ Number of Writes Control 2 (Life Control = User Setting)

The Number of Writes Control Area consists of 3 bytes from the start address. The Number of Writes Control command is executed with a Subtract specification. The specified number of writes is subtracted and the result is written to the control area. Therefore, to enable control of the number of writes, the maximum number of writes must be written to the Number of Writes Control Area beforehand. The user-specified number of writes can be set to up to 16,700,000. The specified number of writes for EEPROM ID Tags, however, is 100,000 writes (0186A0 hex) at 25°C max., so be sure to set the number of writes to 100,000 or less. When the value in the number of writes control area is less than 0, the Status Flag (CIO n+8, bit 04) in the Results Information turns ON. If the value in the control area is already less than 0, the value will not be changed.

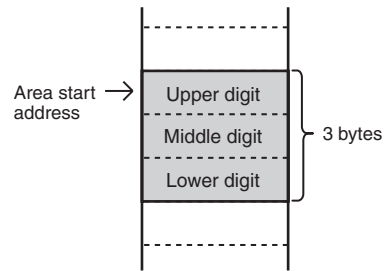

- Application Method

A user-specified number of writes can be used for life control by writing the desired value in the Number of Writes Control Area in advance. The life of the ID Tag can be managed by updating the number of writes value when data is written to the address most frequently written. (The ID Tag has a limited life for any one block of 8 bytes, so the number of writes must be counted for the address that is written most frequently.) It is also possible to confirm the number of writes without updating number of writes value.

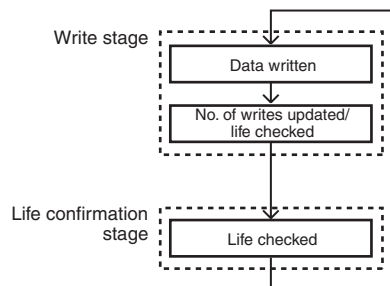

• **Application Example**

The following example uses 3 bytes starting at address 0010 (hex) as the number of writes control area.

1) A Write command is executed to set the control area to 100,000 writes.

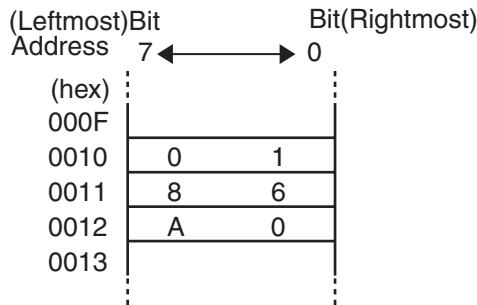

2) The Number of Writes Control command is executed with a Subtract specification and the number of writes set to 5.

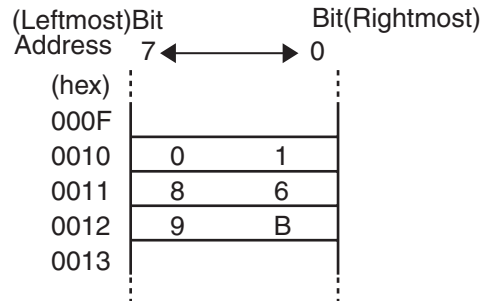

3) The following illustration shows memory status when the total number of writes has reached 100,000 writes. If the Number of Writes Control command is executed with a Subtract specification and the number of writes set to 5, the Status Flag (CIO n+8, bit 04) in the Results Information will turn ON.

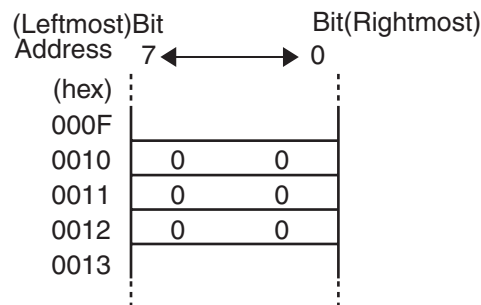

For any one ID Tag, use only an Add specification or a Subtract specification for the Number of Writes Control command. If both specifications are used for the same ID Tag, the number of writes control will not be possible

ID Tag Memory Check

The Memory Check command performs an ID Tag memory check. A CRC (Cyclic Redundancy Check) code calculation, write, and comparison are made using the check block unit specified by the user. The CRC code is calculated from the generated polynomial expression $X^{16} + X^{12} + X^5 + 1$.

A memory check is performed by using the Data Check command with a Calculation processing specification to write the check code and a Verification processing specification to verify the check code. The start address and the number of bytes determine the specified check block. All but the last 2 bytes are the area to calculate and the last 2 bytes are the check code area.

When the Data Check command is executed to write the check code, the CRC code is calculated for the area to calculate and written in the check code area.

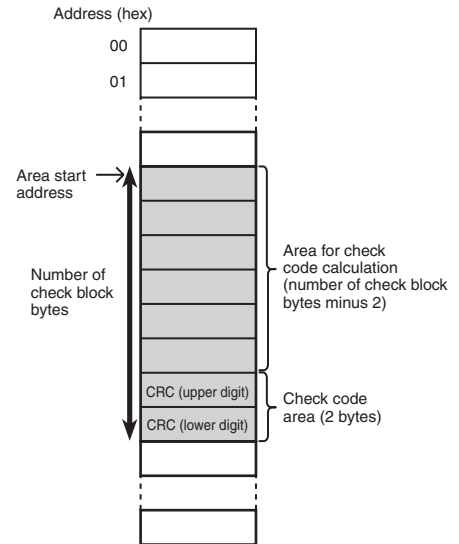

When the Data Check command is executed to verify the check code, the CRC code is calculated for the area to calculate and compared with the data in the check code area. If the calculated code is the same as the data in the check code area, the Normal End Flag (CIO n+7, bit 01) in Unit Status will turn ON. If they are not the same, the Error End Flag (CIO n+7, bit 02) in Unit Status will turn ON, and the Status Flag (CIO n+8, bit 04) in the Results Information will turn ON as a warning.

- Application Method

After writing the data, the Data Check command is executed with a Calculation processing specification to calculate and write the check code. Before reading the data, the Data Check command is executed with a Verification processing specification to verify the check code. This enables detecting internal data corruption that might occur in the ID Tag when the data is not being accessed.

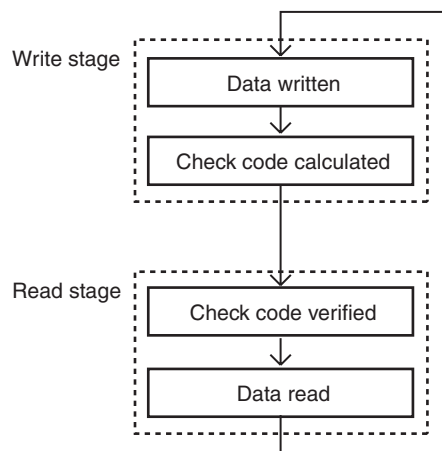

• **Application Example**

The following example checks the data in addresses 0010 to 0012 (hex).

1) Assume that the following data is initially in memory.

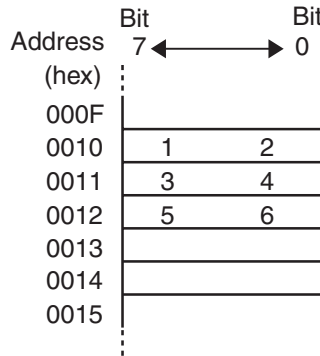

2) The Data Check command is executed to calculate the check code for 5 bytes beginning with address 0010 (hex). The CRC Code 5CD6 hex calculated from the data “123456” is written to addresses 0013 and 0014 (hex).

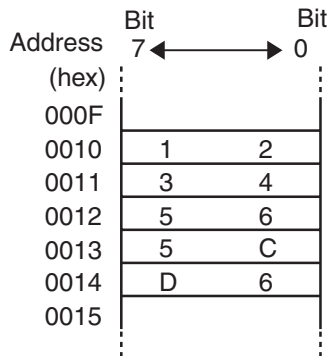

3) The Data Check command is executed to verify the check code for 5 bytes beginning with address 0010 (hex). If the data is normal, the Normal End Flag in Unit Status (CIO n+7, bit 01) is turned ON.

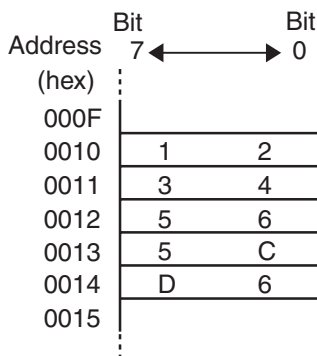

If the check codes are not the same, the Error End Flag (CIO n+7, bit 02) in Unit Status is turned ON.

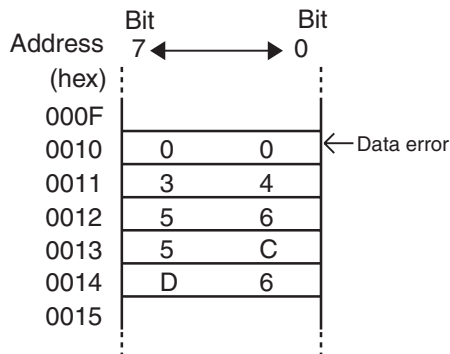

ID Tag Memory Error Correction

The Write with Error Correction command can be used to write an ID Tag memory check code and error correction code to the five bytes of memory after the write data. The Read with Error Correction command performs a tag memory check and makes 1-bit memory error corrections.

When a 1-bit memory error is corrected, the Error Correction Flag (CIO n+8, bit 03) in the Results Information will turn ON to warn that a 1-bit memory error occurred, and the normal data with the error corrected will be returned. When a 2-bit or larger memory error is detected, the Status Flag (CIO n+8, bit 04) in the Results Information turn ON to warn that a fatal error occurred, and the read data will not be returned.

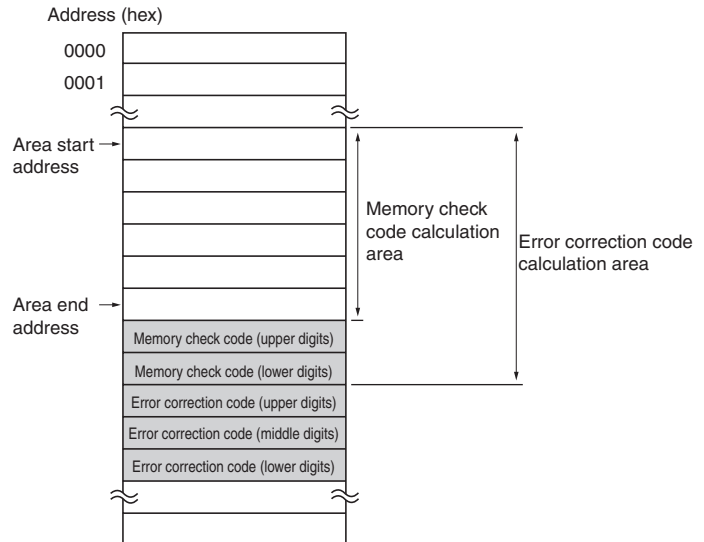

■ Example of ID Tag Memory Error Correction

In the following example, the data in addresses 0010 to 0015 (hex) is checked.

1. Send the Write with Error Correction Command.
 - First word allocated to Special I/O Unit in CIO Area: CIO 20000 + 10 x 0 = CIO 20000

Word address	Contents	Meaning															
		15	14	13	12	11	10	9	8	7	6	5	4	3	2	1	0
CIO 2001	0B 0 0	Command code								Communications specification				Data order			
CIO 2002	00 10	First address to process															
CIO 2003	00 06	Number of bytes to process															
CIO 2004	11 00	Data storage location (lower 4 digits)															
CIO 2005	0 0 00	Data storage area				Bank designation* (always 0)				Data storage location (upper 2 digits)							
CIO 2006	00 00	---															

*: Always 0 when DM Area is specified, --- : Ignored.

2. Data is written to addresses 0010 to 0015 (hex), then an ID Tag memory check code and a error correction code (5 bytes) are written to addresses 0016 to 001A (hex).

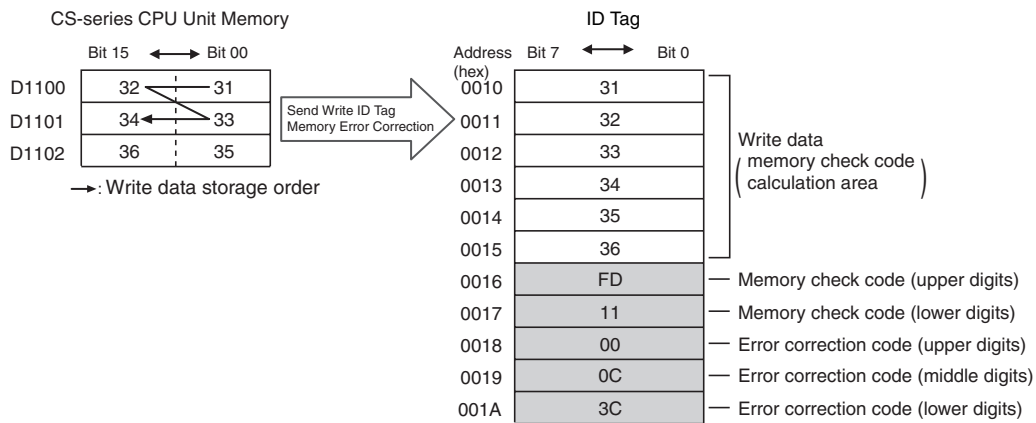

3. Send the Read with Error Correction command.

- First word allocated to Special I/O Unit in CIO Area: CIO 20000 + 10 x 0 = CIO 20000

Word address	Contents	Meaning															
		15	14	13	12	11	10	9	8	7	6	5	4	3	2	1	0
CIO 2001	0B 0 0	Command code								Communications specification				Data order			
CIO 2002	00 10	First address to process															
CIO 2003	00 06	Number of bytes to process															
CIO 2004	11 00	Data storage location (lower 4 digits)															
CIO 2005	0 0 00	Data storage area				Bank specification * (always 0)				Data storage location (upper 2 digits)							
CIO 2006	00 00	---															

*: Always 0 when DM Area is specified, --- : Ignored.

- If the Data Is Normal
The Normal End Flag in Unit Status (CIO n+7, bit 01) turns ON.
- If a Memory Error of 2 Bits or More Is Detected
The Error End Flag in Unit Status (CIO n+7, bit 02) is turned ON, and the Status Flag (CIO n+8, bit 04) in the Results Information is turned ON.
- If a 1-bit Memory Error Is Corrected
The Error End Flag in Unit Status (CIO n+7, bit 02) is turned ON, and the Error Correction Flag (CIO n+8, bit 03) in the Results Information is turned ON as a warning.

MEMO

SECTION 6

Controlling the ID Sensor Unit

▣ ID Sensor Unit Operation	118
▣ Communications Commands	125
▣ Communications Time	141

ID Sensor Unit Operation

The user program in the CS/CJ-series CPU Unit is used to operate the ID Sensor Unit. The ID Sensor Unit performs communications with ID Tags through the Antenna according to data set in the Special I/O Unit Area of the CS/CJ-series CPU Unit.

Outline of Operation

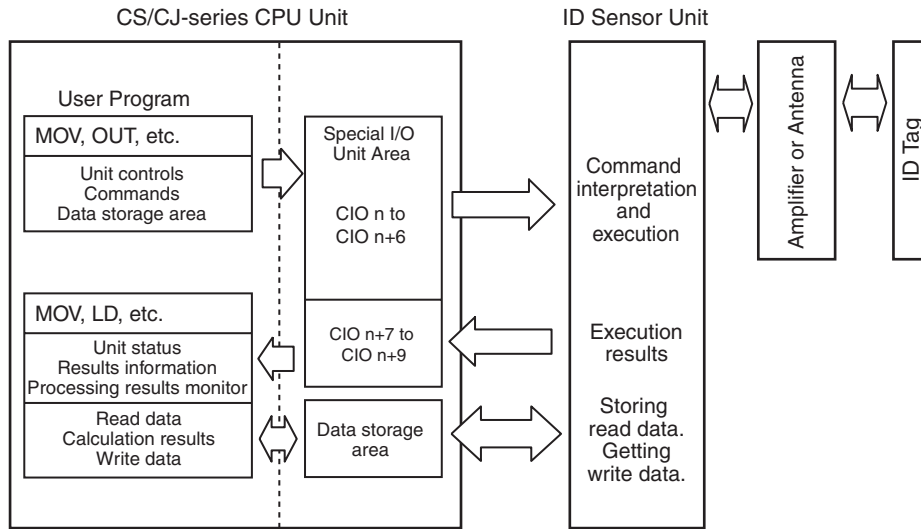

- The ID Sensor Unit will complete execution of any command that is being executed even if the CPU Unit is changed to PROGRAM Mode.
- If an ID Sensor Unit error occurs, communications will stop regardless of the operating mode.
- First word allocated to Unit in CIO Area: $n = \text{CIO } 2000 + 10 \times \text{Unit number}$

Commands Used to Read Data (Cyclic Data Transfer for Read, Read with Error Correction, and UID Read)

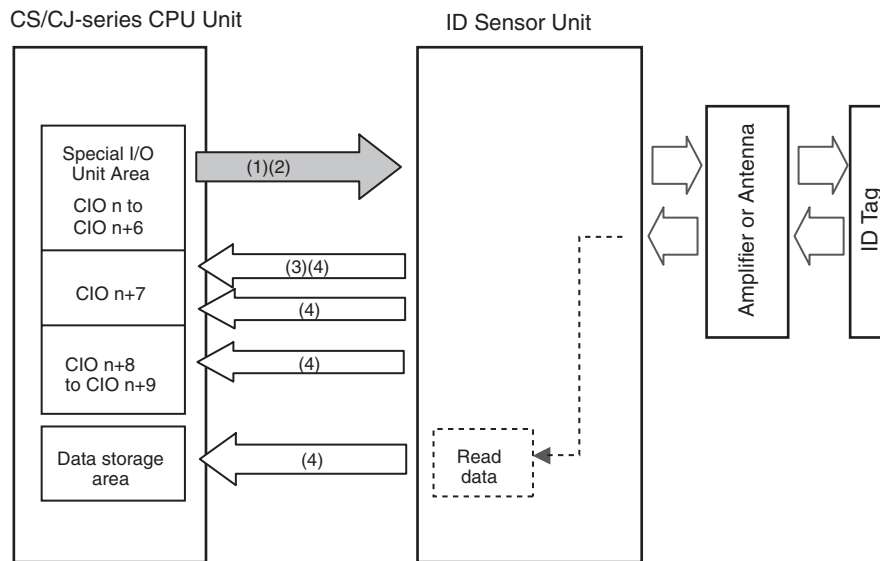

- 1) Use the user program to set the processing address, number of processing bytes, data storage word address, and other parameters for reading ID Tag data in the Special I/O Unit Area.
- 2) Use the user program to turn ON the Command Execution Bit (CIO n, bit 00) in the Special I/O Unit Area.
- 3) When the ID Sensor Unit detects that the Command Execution Bit has turned ON, it turns ON the ID Busy Flag (CIO n+7, bit 00).
- 4) The ID Sensor Unit reads the data from the ID Tag, places the Results Information (CIO n+8) and Processing Results Monitor information (word n+9) in the Special I/O Unit Area, places the data read from the ID Tag in the data storage words, turns OFF the ID Busy Flag (CIO n+7, bit 00), and turns ON the Normal End Flag (CIO n+7, bit 01) for one scan.
- 5) Use the Results Information (CIO n+8), the Processing Results Monitor information (CIO n+9), and the read data stored in the data storage words in the user program only after the Normal End Flag (CIO n+7, bit 01) turns ON. The Results Information (CIO n+8) will be held until the Error Reset Bit (CIO n, bit 01) is turned ON or until the next communications command is received.

- Data is transferred to the data storage words at a rate of 160 bytes per scan.



Commands Used to Read Data (Intelligent I/O Instruction Data Transfer for Read and Read with Error Correction)

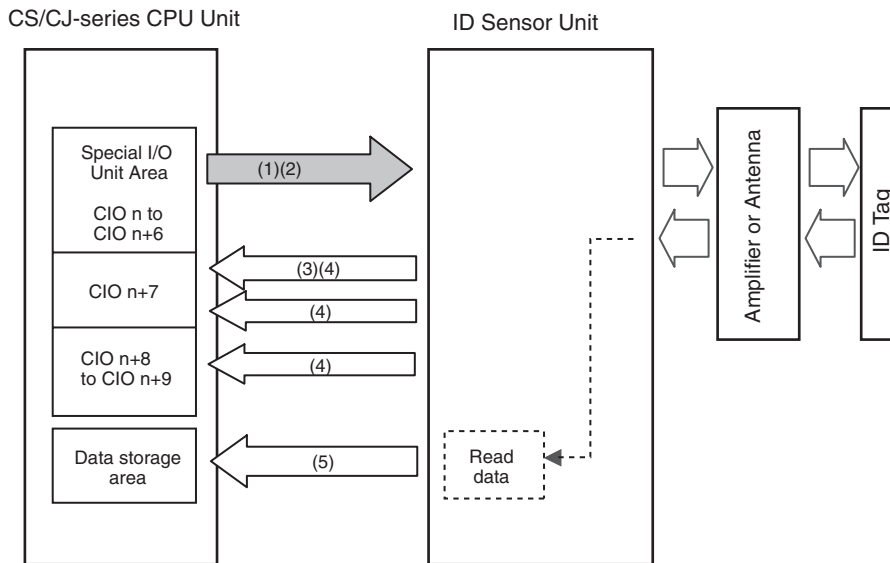

- 1) Use the user program to set the processing address, number of processing bytes, data storage word address, and other parameters for reading ID Tag data in the Special I/O Unit Area.
- 2) Use the user program to turn ON the Command Execution Bit (CIO n, bit 00) in the Special I/O Unit Area.
- 3) When the ID Sensor Unit detects that the Command Execution Bit has turned ON, it turns ON the ID Busy Flag (CIO n+7, bit 00).
- 4) The ID Sensor Unit reads the data from the ID Tag, places the Results Information (CIO n+8) and Processing Results Monitor information (word n+9) in the Special I/O Unit Area, turns OFF the ID Busy Flag (CIO n+7, bit 00), and turns ON the Normal End Flag (CIO n+7, bit 01) for one scan.
- 5) Use the IORD instruction in the user program to transfer the read data to the data storage words after the Normal End Flag (CIO n+7, bit 01) turns ON. Then use the Results Information (CIO n+8), the Processing Results Monitor information (CIO n+9), and the read data.
The Results Information (CIO n+8) will be held until the Error Reset Bit (CIO n, bit 01) is turned ON or until the next communications command is received.



- By using the IORD instruction, up to 2,048 bytes of data can be transferred in one scan.

Commands Used to Write Data (Cyclic Data Transfer for Write, Bit Set, Bit Clear, Mask Bit Write, Calculation Write, Data Fill, Data Check, Number of Writes Control, and Write with Error Correction)

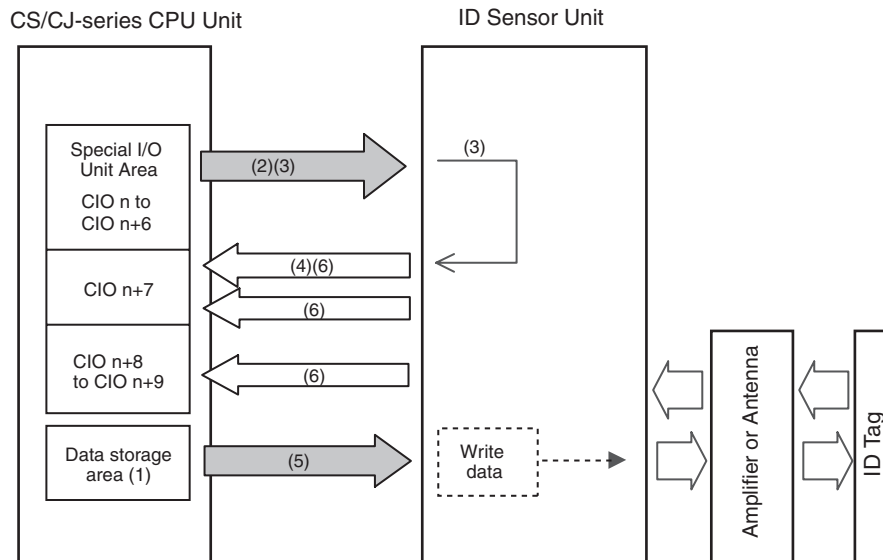

- 1) Use the user program to set the write data in the data storage area.
- 2) Use the user program to set the processing address, number of processing bytes, data storage word address, and other parameters for writing ID Tag data in the Special I/O Unit Area.
- 3) Use the user program to turn ON the Command Execution Bit (CIO n, bit 00) in the Special I/O Unit Area.
- 4) When the ID Sensor Unit detects that the Command Execution Bit has turned ON, it turns ON the ID Busy Flag (CIO n+7, bit 00).
- 5) The ID Sensor Unit reads the write data from the data storage words to internal memory and then writes the data to the ID Tag.
- 6) The ID Sensor Unit writes the data to the ID Tag, places the Results Information (CIO n+8) and Processing Results Monitor information (word n+9) in the Special I/O Unit Area, turns OFF the ID Busy Flag (CIO n+7, bit 00), and turns ON the Normal End Flag (CIO n+7, bit 01) for one scan.

The Results Information (CIO n+8) will be held until the Error Reset Bit (CIO n, bit 01) is turned ON or until the next communications command is received.



- Data is transferred to the data storage words at a rate of 160 bytes per scan.

Commands Used to Write Data (Intelligent I/O Instruction Data Transfer for Write and Write with Error Correction)

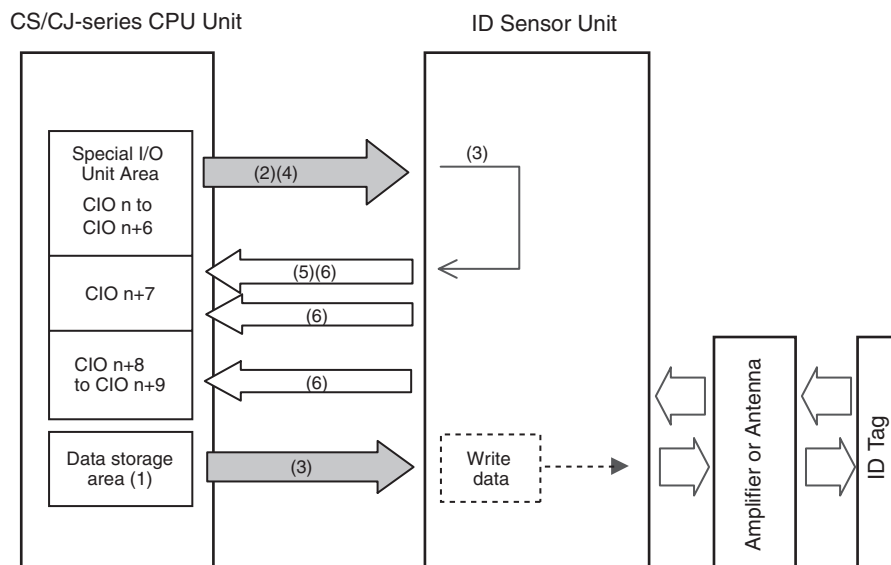

- 1) Use the user program to set the write data in the data storage area.
- 2) Use the user program to set the processing address, number of processing bytes, data storage word address, and other parameters for writing ID Tag data in the Special I/O Unit Area.
- 3) Use the IOWR instruction in the user program to transfer the write data in the data storage words to the ID Sensor Unit.
- 4) Use the user program to turn ON the Command Execution Bit (CIO n, bit 00) in the Special I/O Unit Area.
- 5) When the ID Sensor Unit detects that the Command Execution Bit has turned ON, it turns ON the ID Busy Flag (CIO n+7, bit 00).
- 6) The ID Sensor Unit writes the data to the ID Tag, places the Results Information (CIO n+8) and Processing Results Monitor information (word n+9) in the Special I/O Unit Area, turns OFF the ID Busy Flag (CIO n+7, bit 00), and turns ON the Normal End Flag (CIO n+7, bit 01) for one scan.

The Results Information (CIO n+8) will be held until the Error Reset Bit (CIO n, bit 01) is turned ON or until the next communications command is received.



- By using the IOWR instruction, up to 2,048 bytes of data can be transferred in one scan.

Copy Command

The following example shows writing the data from ID Tag A for Antenna 1 to ID Tag B for Antenna 2.

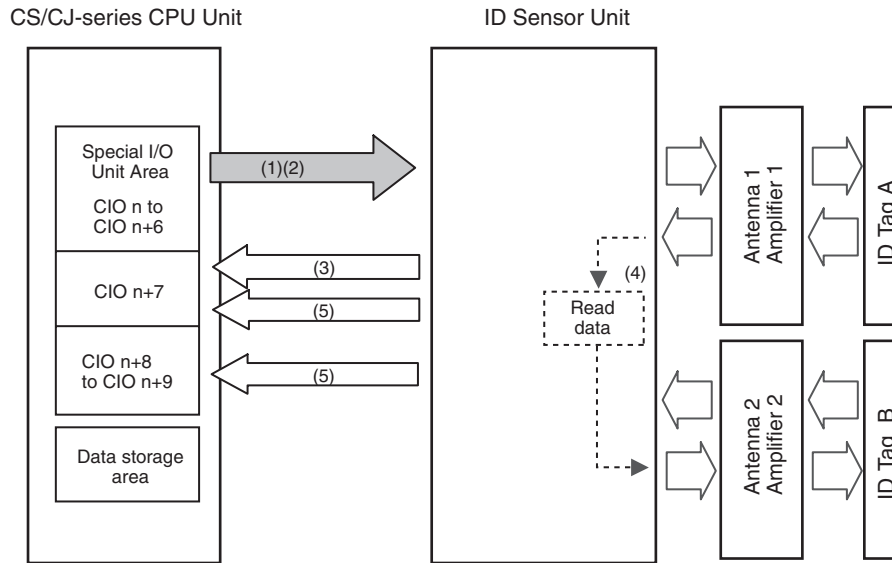

- 1) Use the user program to set the processing address, number of processing bytes, data storage word address, and other parameters for copying ID Tag data in the Special I/O Unit Area.
- 2) Use the user program to turn ON the Command Execution Bit (CIO n, bit 00) in the Special I/O Unit Area.
- 3) When the ID Sensor Unit detects that the Command Execution Bit has turned ON, it turns ON the ID Busy Flag (CIO n+7, bit 00).
- 4) The ID Sensor Unit will read data from ID Tag A and write it to ID Tag B.
- 5) The ID Sensor Unit writes the data to the ID Tag, places the Results Information (CIO n+8) and Processing Results Monitor information (word n+9) in the Special I/O Unit Area, turns OFF the ID Busy Flag (CIO n+7, bit 00), and turns ON the Normal End Flag (CIO n+7, bit 01) for one scan.

The Results Information (CIO n+8) will be held until the Error Reset Bit (CIO n, bit 01) is turned ON or until the next communications command is received.

Noise Measurement Command

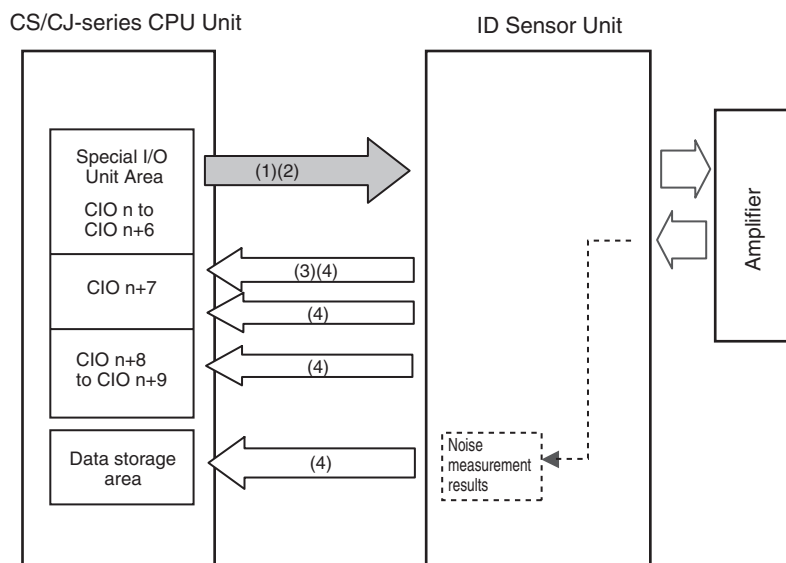

- 1) Use the user program to set the storage words for noise measurement data and other parameters in the Special I/O Unit Area.
- 2) Use the user program to turn ON the Command Execution Bit (CIO n, bit 00) in the Special I/O Unit Area.
- 3) When the ID Sensor Unit detects that the Command Execution Bit has turned ON, it turns ON the ID Busy Flag (CIO n+7, bit 00).
- 4) The ID Sensor Unit measures the noise around the Antenna, places the Results Information (CIO n+8) and Processing Results Monitor information (word n+9) in the Special I/O Unit Area, places the noise measurement results in the data storage words, turns OFF the ID Busy Flag (CIO n+7, bit 00), and turns ON the Normal End Flag (CIO n+7, bit 01) for one scan.
- 5) Use the Results Information (CIO n+8), the Processing Results Monitor information (CIO n+9), and noise measurement results in the data storage words in the user program only after the Normal End Flag (CIO n+7, bit 01) turns ON.

Communications Commands

Commands

Command name	Command code	Function
Read	00	Reads data from the ID Tag's memory.
Write	01	Writes data to the ID Tag's memory.
Bit Set	02	Sets the specified bits of the specified area in the ID Tag.
Bit Clear	03	Clears the specified bits of the specified area in the ID Tag.
Mask Bit Write	04	Masks the specified bits in the specified area of the ID Tag and writes data to the bits that are not masked.
Calculation Write	05	Writes the calculation result between memory data and the specified data to the ID Tag.
Data Fill	06	Writes the specified data to the specified area of the ID Tag.
Data Check	07	Calculates and verifies check codes for ID Tag memory.
Number of Writes Control	08	Controls ID Tag write life.
Copy	09	Writes the data read from an ID Tag by one Antenna to the ID Tag for the other Antenna. This command is supported by Two-channels ID Sensor Units only.
Read with Error Correction	0A	Reads data from the ID Tag's memory. Also uses a memory check code to check data reliability.
Write with Error Correction	0B	Writes data to the ID Tag's memory. Also writes the memory check code for the data reliability checking to the memory of the Tag.
UID Read	0C	Reads the ID Tag's ID code.
Noise Measurement	10	Measures the noise and returns the noise level as the measurement result.





- The Data Fill command will write data to the user area in the ID Tag regardless of the setting of write protection
- If there is an error in the command or option specifications, the Command Error Flag (CIO n+8, bit 00) in the Results Information will turn ON and the command will not be executed.

Command Descriptions

■ Read

Reads the specified number of bytes from the specified start address in the ID Tag.
Up to 2,048 bytes (i.e., 1,024 words) can be read with one command execution.



Word address		Bit No.	Type	Bit name	Description
Antenna 1 of CS1W-V680C11, CS1W-V680C12, CJ1W-V680C11, or CJ1W-V680C12	Antenna 2 of CS1W-V680C12 or CJ1W-V680C12				
n+1	n+11	08 to 15	Command	Command Code	00 hex
		04 to 07		Communications Specification  p. 85	Specify the communications method with the ID Tag.
				0	Trigger
				1	Single Auto
				2	Repeat Auto
				3	FIFO trigger
				4	FIFO repeat
				5	Multi-access trigger
		6		Multi-access repeat	
		00 to 03		Processing Specification  p. 71	Specify the read data storage order.
0	Leftmost → Rightmost				
		1	Rightmost → Leftmost		
n+2	n+12	00 to 15		Processing Address	Specify the first ID Tag address to read, Setting range: 0000 to FFFF hex
n+3	n+13	00 to 15		Number of Processing Bytes	Specify the number of ID Tag read bytes. Setting range: 0001 to 0800 hex
n+4	n+14	00 to 15	Data storage area	Data Storage Word Address (rightmost 4 digits)  p. 71	Specify the read data storage destination.
n+5	n+15	12 to 15		Data Storage Area	
		08 to 11		Bank Specification	
		00 to 07		Data Storage Word Address (leftmost 2 digits)	
n+6	n+16	00 to 15	Option	Command Option	Not used



- Check the memory capacity of the ID Tag before setting the Processing Address and Number of Processing Bytes. If the Processing Address and Number of Processing Bytes are not suitable for the ID Tags for which communications are being performed, the ID Tag Address Error Flag (CIO n+8, bit 13) will turn ON.

Write

Writes the specified number of bytes of data beginning at the specified start address in the ID Tag. Up to 2,048 bytes (i.e., 1,024 words) can be written with one command execution.

Word address		Bit No.	Type	Bit name	Description	
Antenna 1 of CS1W-V680C11, CS1W-V680C12, CJ1W-V680C11, or CJ1W-V680C12	Antenna 2 of CS1W-V680C12 or CJ1W-V680C12					
n+1	n+11	08 to 15	Command	Command code	01 hex	
		04 to 07		Communications Specification  p. 85	Specify the communications method with the ID Tag.	
				0	Trigger	
				1	Single auto	
				2	Repeat auto	
				3	FIFO trigger	
				4	FIFO repeat	
				5	Multi-access trigger	
		6		Multi-access repeat		
		00 to 03		Processing Specification  p. 71	Specify the write data storage order.	
0	Leftmost → Rightmost					
1	Rightmost → Leftmost					
n+2	n+12	00 to 15	Option	Processing Address	Specify the first ID Tag address to write. Setting range: 0000 to FFFF hex	
n+3	n+13	00 to 15		Number of Processing Bytes	Specify number of ID Tag write bytes. Setting range: 0001 to 0800 hex	
n+4	n+14	00 to 15	Data storage area	Data Storage Word Address (rightmost 4 digits)  p. 71	Specify the write data storage destination.	
n+5	n+15	12 to 15		Data Storage Area		
		08 to 11		Bank Specification		
		00 to 07		Data Storage Word Address (leftmost 2 digits)		
n+6	n+16	00 to 15	Option	Command Option	Not used.	



- Verification will not be performed if No Verification is set for writing.





- Check the memory capacity of the ID Tag before setting the Processing Address and Number of Processing Bytes. If the Processing Address and Number of Processing Bytes are not suitable for the ID Tags for which communications are being performed, the ID Tag Address Error Flag (CIO n+8, bit 13) will turn ON.

Bit Set

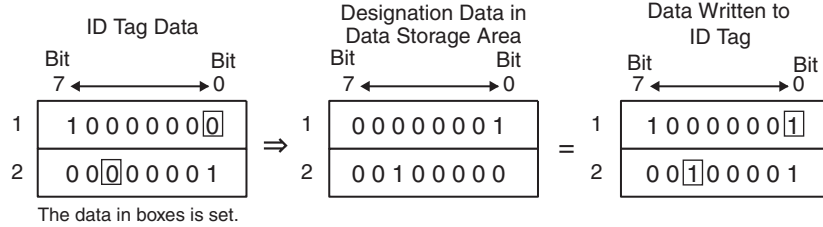
Reads the specified number of bytes from the specified start address and sets the specified bits to 1. For the Designation Data, set a hexadecimal value with the bits to be set to 1 turned ON. Up to 4 bytes (i.e., 2 words) can be specified for one command execution. The following example shows specifying 0120 hex for 2 bytes of data to set bit 0 in byte 1 and bit 5 in byte 2.



Word address		Bit No.	Type	Bit name	Description
Antenna 1 of CS1W-V680C11, CS1W-V680C12, CJ1W-V680C11, or CJ1W-V680C12	Antenna 2 of CS1W-V680C12 or CJ1W-V680C12				
n+1	n+11	08 to 15	Command	Command	02 hex
		04 to 07		Communications Specification  p. 85	Specify the communications method with the ID Tag.
				0	Trigger
				1	Single auto
				2	Repeat auto
				3	FIFO trigger
				4	FIFO repeat
00 to 03	Processing Specification  p. 71	Specify the storage order for the Designation Data.			
		0	Leftmost → Rightmost		
		1	Rightmost → Leftmost		
n+2	n+12	00 to 15	Processing Address	Specify the first ID Tag address to write. Setting range: 0000 to FFFF hex	
n+3	n+13	00 to 15	Number of Processing Bytes	Specify number of ID Tag bytes to write. Setting range: 0001 to 0004 hex	
n+4	n+14	00 to 15	Data storage area	Data Storage Word Address (rightmost 4 digits)  p. 71	Specify the write data storage destination.
n+5	n+15	12 to 15		Data Storage Area	
		08 to 11		Bank Specification	
		00 to 07		Data Storage Word Address (leftmost 2 digits)	
n+6	n+16	00 to 15	Option	Command Option	Not used



- Data status will not be changed for any bit that is OFF in the Designation Data.
- Verification will not be performed if No Verification is set for writing.



- Check the memory capacity of the ID Tag before setting the Processing Address and Number of Processing Bytes. If the Processing Address and Number of Processing Bytes are not suitable for the ID Tag for which communications are being performed, the ID Tag Address Error Flag (CIO n+8, bit 13) will turn ON.

Bit Clear

Reads the specified number of bytes from the specified start address and clears the specified bits to 0. For the Designation Data, set a hexadecimal value with the bits to be cleared to 0 turned ON.

Up to 4 bytes (i.e., 2 words) can be specified for one command execution.

The following example shows specifying 100140 hex for 3 bytes of data to clear bit 4 in byte 1, bit 0 in byte 2, and bit 6 in byte 3.

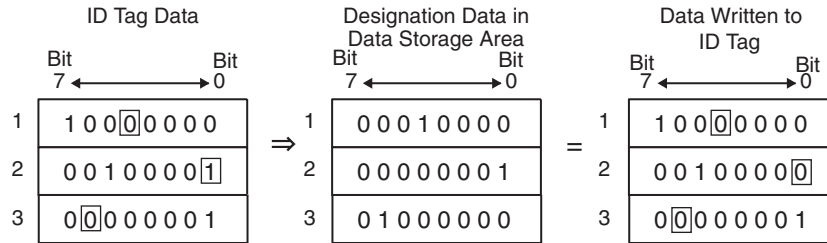

The data in boxes is cleared.

Word address		Bit No.	Type	Bit name	Description
Antenna 1 of CS1W-V680C11, CS1W-V680C12, CJ1W-V680C11, or CJ1W-V680C12	Antenna 2 of CS1W-V680C12 or CJ1W-V680C12				
n+1	n+11	08 to 15	Command	Command code	03 hex
		04 to 07		Communications Specification p. 85	Specify the communications method with the ID Tag.
				0	Trigger
				1	Single auto
				2	Repeat auto
				3	FIFO trigger
				4	FIFO repeat
00 to 03	Processing Specification p. 71	Specify the storage order for the Designation Data.			
		0	Leftmost → Rightmost		
		1	Rightmost → Leftmost		
n+2	n+12	00 to 15	Processing Address	Specify the first ID Tag address to write. Setting range: 0000 to FFFF hex	
n+3	n+13	00 to 15	Number of Processing Bytes	Specify number of ID Tag bytes to write. Setting range: 0001 to 0004 hex	
n+4	n+14	00 to 15	Data Storage Word Address (rightmost 4 digits)	Specify the write data storage destination. p. 71	
n+5	n+15	12 to 15	Data Storage Area		
		08 to 11	Bank Specification		
		00 to 07	Data Storage Word Address (leftmost 2 digits)		
n+6	n+16	00 to 15	Option	Command Option	Not used



- Data status will not be changed for any bit that is OFF in the Designation Data.
- Verification will not be performed if No Verification is set for writing.

CHECK!



- Check the memory capacity of the ID Tag before setting the Processing Address and Number of Processing Bytes. If the Processing Address and Number of Processing Bytes are not suitable for the ID Tag for which communications are being performed, the ID Tag Address Error Flag (CIO n+8, bit 13) will turn ON.

CHECK!

Mask Bit Write

Reads the 2 bytes of data from the specified start address, masks it with the specified mask data, and writes data to the bits that are not masked. For the mask data, set a hexadecimal value with the bits to be masked turned ON.

Each command execution processes 2 bytes (i.e., 1 word).

Example for a Masked Bit Write

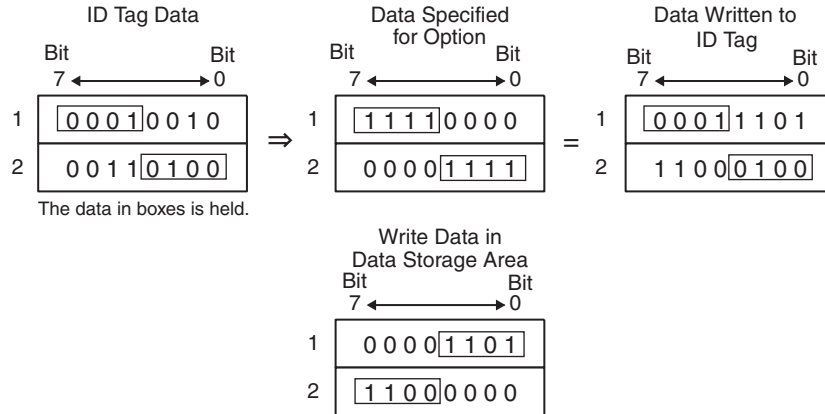

Word address		Bit No.	Type	Bit name	Description
Antenna 1 of CS1W-V680C11, CS1W-V680C12, CJ1W-V680C11, or CJ1W-V680C12	Antenna 2 of CS1W-V680C12 or CJ1W-V680C12				
n+1	n+11	08 to 15	Command	Command code	04 hex
		04 to 07		Communications Specification p. 85	Specify the communications method with the ID Tag.
				0	Trigger
				1	Single auto
				2	Repeat auto
				3	FIFO trigger
				4	FIFO repeat
00 to 03	Processing Specification p. 71	Specify the write data storage order.			
		0	Leftmost → Rightmost		
		1	Rightmost → Leftmost		
n+2	n+12	00 to 15	Processing Address	Specify the first ID Tag address to write. Setting range: 0000 to FFFE hex	
n+3	n+13	00 to 15	Number of Processing Bytes	Not used	
n+4	n+14	00 to 15	Data storage area	Data Storage Word Address (rightmost 4 digits) p. 71	Specify the write data storage destination.
n+5	n+15	12 to 15		Data Storage Area	
		08 to 11		Bank Specification	
		00 to 07		Data Storage Word Address (leftmost 2 digits)	
n+6	n+16	00 to 15	Option	Command Option	Mask data (0000 to FFFE hex)



CHECK!

- The bits that are turned ON in the data set for the Command Option will be masked and will not be changed. Write data will be written to the data storage area for bits that are OFF in the write data.
- Verification will not be performed if No Verification is set for writing.



CHECK!

- Check the memory capacity of the ID Tag before setting the Processing Address and Number of Processing Bytes. If the Processing Address and Number of Processing Bytes are not suitable for the ID Tag for which communications are being performed, the ID Tag Address Error Flag (CIO n+8, bit 13) will turn ON.



CHECK!

- The mask data is always specified leftmost to rightmost regardless of the processing specification.

Calculation Write

Reads the specified number of bytes from the specified start address, performs the specified calculation with the data specified for the Command Option, and writes the result. The calculation result is stored in the data storage area.

Up to 4 bytes (i.e., 2 words) can be specified for one command execution.

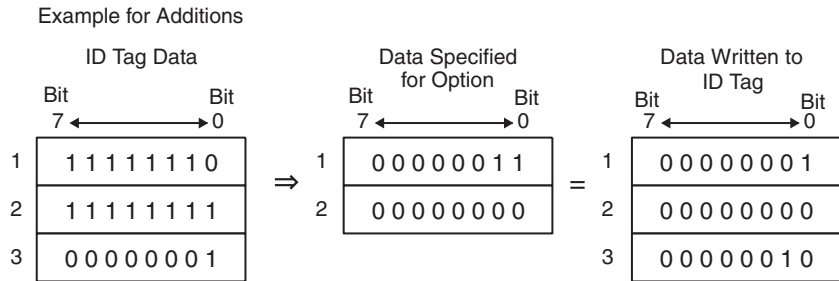

Word address		Bit No.	Type	Bit name	Description
Antenna 1 of CS1W-V680C11, CS1W-V680C12, CJ1W-V680C11, or CJ1W-V680C12	Antenna 2 of CS1W-V680C12 or CJ1W-V680C12				
n+1	n+11	08 to 15	Command	Command code	05 hex
		07 to 04		Communications Specification p. 85	Specify the communications method with the ID Tag.
				0	Trigger
				1	Single auto
				2	Repeat auto
				3	FIFO trigger
				4	FIFO repeat
00 to 03	Processing Specification p. 71	Specify the calculation method.			
		0	Add		
		1	Subtract		
n+2	n+12	00 to 15		Processing Address	Specify the first ID Tag address to write. Setting range: 0000 to FFFF hex
n+3	n+13	00 to 15		Number of Processing Bytes	Specify number of ID Tag write bytes. Setting range: 0001 to 0004 hex
n+4	n+14	00 to 15	Data storage area	Data Storage Word Address (rightmost 4 digits) p. 71	Specify the calculation result storage area.
n+5	n+15	12 to 15		Data Storage Area	
		08 to 11		Bank Specification	
		00 to 07		Data Storage Word Address (leftmost 2 digits)	
n+6	n+16	00 to 15	Option	Command Option	Calculation data



- If an addition results in an overflow or a subtraction results in an underflow, the Status Flag (CIO n+8, bit 04) will turn ON and the number of writes data will not be changed.
- Verification will not be performed if No Verification is set for writing.





- Check the memory capacity of the ID Tag before setting the Processing Address and Number of Processing Bytes. If the Processing Address and Number of Processing Bytes are not suitable for the ID Tag for which communications are being performed, the ID Tag Address Error Flag (CIO n+8, bit 13) will turn ON.

■ Data Fill

Writes the designated fill data to the ID Tag beginning from the specified start address.

The maximum amount of data that can be written in a single execution is 2,048 bytes (1,024 words), or to the entire remaining area after the specified start address.

Word address		Bit No.	Type	Bit name	Description	
Antenna 1 of CS1W-V680C11, CS1W-V680C12, CJ1W-V680C11, or CJ1W-V680C12	Antenna 2 of CS1W-V680C12 or CJ1W-V680C12					
n+1	n+11	08 to 15	Command	Command code	06 hex	
		04 to 07		Communications Specification  p. 85	Specify the communications method with the ID Tag.	
					0	Trigger
					1	Single auto
					2	Repeat auto
					3	FIFO trigger
					4	FIFO repeat
					5	Multi-access trigger
		6		Multi-access repeat		
		00 to 03		Processing Specification  p. 71	Specify the fill data size.	
0	Bytes (Command option rightmost 8 bits)					
		1	Words			
n+2	n+12	00 to 15		Processing Address	Specify the first ID Tag address to write. Setting range: 0000 to FFFF hex	
n+3	n+13	00 to 15		Number of Processing Bytes	Specify number of ID Tag write bytes. Setting range: 0000, 0001 to 0800 hex. 0000 hex: Fill data is written to the ID Tag's end address.	
n+4	n+14	00 to 15	Data storage area	Data Storage Word Address (rightmost 4 digits)	Not used	
n+5	n+15	12 to 15		Data Storage Area		
		08 to 11		Bank Specification		
		00 to 07		Data Storage Word Address (leftmost 2 digits)		
n+6	n+16	00 to 15	Option	Command Option	Fill data. Setting range: 0000 to FFFF hex	



- If the Number of Processing Bytes is 0000 hex, data will be written to user area of the ID Tag from the start address to the end address.
- The Data Fill command will write data to the user area in the ID Tag regardless of the setting of write protection.
- Verification will not be performed if No Verification is set for writing.





- Check the memory capacity of the ID Tag before setting the Processing Address and Number of Processing Bytes. If the Processing Address and Number of Processing Bytes are not suitable for the ID Tag for which communications are being performed, ID Tag Address Error Flag (CIO n+8, bit 13) will turn ON.

■ Data Check

Finds the CRC code for the data area from the specified start address to 2 bytes less than the specified number of bytes and writes 2 bytes of data.

From 3 to 2,048 bytes of data can be specified for one command execution.

Word address		Bit No.	Type	Bit name	Description
Antenna 1 of CS1W-V680C11, CS1W-V680C12, CJ1W-V680C11, or CJ1W-V680C12	Antenna 2 of CS1W-V680C12 or CJ1W-V680C12				
n+1	n+11	08 to 15	Command	Command code	07 hex
		04 to 07		Communications specification  p. 85	Specify the communications method with the ID Tag.
				0 Trigger	1 Single auto
		00 to 03		Processing Specification  p. 71	Specify the process.
				0 CRC calculation	1 CRC verification
n+2	n+12	00 to 15		Processing Address	Specify the Data Check Start address in the ID Tag. Setting range: 0000 to FFFD hex
n+3	n+13	00 to 15		Number of Processing Bytes	Specify the number of bytes in the data check range in the ID Tag plus 2 bytes. Setting range: 0003 to 0800 hex
n+4	n+14	00 to 15	Data storage area	Data Storage Word Address (rightmost 4 digits)	No used
n+5	n+15	12 to 15		Data Storage Area	
		08 to 11		Bank Specification	
		00 to 07		Data Storage Word Address (leftmost 2 digits)	
n+6	n+16	00 to 15	Option	Command Option	No used



CHECK!

- Verification will not be performed if No Verification is set for writing.





CHECK!

- The last 2 bytes of the check area is the check code area. Do not write user data to these bytes.
- Check the memory capacity of the ID Tag before setting the Processing Address and Number of Processing Bytes. If the Processing Address and Number of Processing Bytes are not suitable for the ID Tag for which communications are being performed, ID Tag Address Error (CIO n+8, bit 13) will turn ON.

■ Number of Writes Control

Uses 3 bytes of data from the specified start address as the Number of Writes Control Area and writes data to the ID Tag.

The number of writes for one command execution can be from 0 to 255.

Word address		Bit No.	Type	Bit name	Description
Antenna 1 of CS1W-V680C11, CS1W-V680C12, CJ1W-V680C11, or CJ1W-V680C12	Antenna 2 of CS1W-V680C12 or CJ1W-V680C12				
n+1	n+11	08 to 15	Command	Command code	08 hex
		04 to 07		Communications Specification  p. 85	Specify the communications method with the ID Tag.
				0	Trigger
				1	Single auto
		00 to 03		Processing Specification  p. 71	Specify the count update method.
				0	Add
		1	Subtract		
n+2	n+12	00 to 15		Processing Address	Specify the start address of the Number of Writes Control Area in the ID Tag. Setting range: 0000 to FFFD hex
n+3	n+13	00 to 15		Number of Processing Bytes	Not used
n+4	n+14	00 to 15	Data storage area	Data Storage Word Address (rightmost 4 digits)  p. 71	Specify the count update results storage area.
n+5	n+15	12 to 15		Data Storage Area	
		08 to 11		Bank Specification	
		00 to 07		Data Storage Word Address (leftmost 2 digits)	
n+6	n+16	00 to 15	Option	Command Option	Number of writes Setting range: 0000 to 00FF hex



CHECK!

- Verification will not be performed if No Verification is set for writing.





CHECK!

- Check the memory capacity of the ID Tag before setting the Processing Address and Number of Processing Bytes. If the Processing Address and Number of Processing Bytes are not suitable for the ID Tag for which communications are being performed, the ID Tag Address Error Flag (CIO n+8, bit 13) will turn ON.

■ Copy (Two-channels ID Sensor Units Only)

This command is supported by Two-channels ID Sensor Units only. Data is read from the ID Tag for one Antenna and written to the memory of an ID Tag in the communications area for the other Antenna.

Writing to the second ID Tag is always performed with a trigger

Word address		Bit No.	Type	Bit name	Description
Antenna 1 of CS1W-V680C12 or CJ1W-V680C12	Antenna 2 of CS1W-V680C12 or CJ1W-V680C12				
n+1	n+11	08 to 15	Command	Command code	09 hex
		04 to 07		Communications Specification  p. 85	Specify the communications method for the ID Tag to be read.
				0 Trigger 1 Single auto	
		00 to 03		Processing Specification  p. 71	Not used
n+2	n+12	00 to 15	---	Processing Address	Specify the first ID Tag address to read. Setting range: 0000 to FFFF hex
n+3	n+13	00 to 15	---	Number of Processing Bytes	Specify the number of ID Tag read bytes Setting range: 0001 to 0800 hex
n+4	n+14	00 to 15	Data storage area	Data Storage Word Address (rightmost 4 digits)	Not used
n+5	n+15	12 to 15		Data Storage Area	
		08 to 11		Bank Specification	
		00 to 07		Data Storage Word Address (leftmost 2 digits)	
n+6	n+16	00 to 15	Option	Command Option	Specify the first ID Tag address to write. Setting range: 0000 to FFFF hex



CHECK!

- If the Command Execution Bit is turned ON in the Unit Controls for Antenna 1, data will be read from the ID Tag for Antenna 1 and written to the ID Tag for Antenna 2.
- If the Command Execution Bit is turned ON in the Unit Controls for Antenna 2, data will be read from the ID Tag for Antenna 2 and written to the ID Tag for Antenna 1.
- The Communications Specification for the Antenna that writes data will always be a trigger regardless of the specified communications method.
- The Status Flag (CIO n+8, bit 04) in the Results Information will turn ON if an error occurs in the Antenna that writes data.





CHECK!

- Confirm that the Antenna that writes data is not communicating before turning ON the Command Execution Bit. If the Antenna that writes data is communicating, the Status Flag (CIO n+8, bit 04) in the Results Information will turn ON.
- Confirm the capacity of both the ID Tag being read and the one being written before using this command. If the Processing Address and Number of Processing Bytes for the Antenna that write data are not suitable for the ID Tag being communicated with, the Status Flag (CIO n+8, bit 04) in the Results Information will turn ON.

Read with Error Correction

Reads the data from the ID Tag from an area written by the Write with Error Correction Command, and performs an error check and 1-bit error correction.

Up to 510 bytes (i.e., 255 words) can be specified for one command execution.

Word address		Bit No.	Type	Bit name	Description
Antenna 1 of CS1W-V680C11, CS1W-V680C12, CJ1W-V680C11, or CJ1W-V680C12	Antenna 2 of CS1W-V680C12 or CJ1W-V680C12				
n+1	n+11	08 to 15	Command	Command code	0A hex
		04 to 07		Communications Specification  p. 85	Specify the communications method with the ID Tag.
				0	Trigger
				1	Single auto
				2	Repeat auto
				3	FIFO trigger
				4	FIFO repeat
				5	Multi-access trigger
		6		Multi-access repeat	
		00 to 03		Processing Specification  p. 71	Specify the read data storage order.
0	Leftmost → Rightmost				
		1	Rightmost → Leftmost		
n+2	n+12	00 to 15		Processing Address	Specify the first ID Tag address to read. Setting range: 0000 to FFFA hex
n+3	n+13	00 to 15		Number of Processing Bytes	Specify the number of ID Tag read bytes. Setting range: 0001 to 01FE hex
n+4	n+14	00 to 15	Data storage area	Data Storage Word Address (rightmost 4 digits)  p. 71	Specify the read data storage destination.
				Data Storage Area	
				Bank Specification	
				Data Storage Word Address (leftmost 2 digits)	
n+5	n+15	12 to 15			
		08 to 11			
		00 to 07			
n+6	n+16	00 to 15	Option	Command Option	No used



CHECK!

- Be sure to read the same area that was written by the Write with Error Correction Command.



CHECK!

- Check the memory capacity of the ID Tag before setting the Processing Address and Number of Processing Bytes. If the Processing Address and Number of Processing Bytes are not suitable for the ID Tag for which communications are being performed, the ID Tag Address Error Flag (CIO n+8, bit 13) will turn ON.





CHECK!

- The five bytes of data after the area extending from the Processing Address for the Number of Processing Bytes is the check code area. Do not write any data to the check code area.
- Check the memory capacity of the ID Tag before setting the Processing Address and Number of Processing Bytes. If the Processing Address and Number of Processing Bytes are not suitable for the ID Tag for which communications are being performed, the ID Tag Address Error Flag (CIO n+8, bit 13) will turn ON.

Write with Error Correction

Writes the designated data to the ID Tag beginning from the specified start address, and writes the Tag memory check code and error correction code to the next 5 bytes of memory. Do not change this code. It is required by the Read with Error Correction command.

Up to 510 bytes (i.e., 255 words) can be specified for one command execution.

Word address		Bit No.	Type	Bit name	Description	
Antenna 1 of CS1W-V680C11, CS1W-V680C12, CJ1W-V680C11, or CJ1W-V680C12	Antenna 2 of CS1W-V680C12 or CJ1W-V680C12					
n+1	n+11	08 to 15	Command	Command code	0B hex	
		04 to 07		Communications Specification  p. 85	Specify the communications method with the ID Tag.	
				0	Trigger	
				1	Single auto	
				2	Repeat auto	
				3	FIFO trigger	
				4	FIFO repeat	
				5	Multi-access trigger	
		6		Multi-access repeat		
		00 to 03		Processing Specification  p. 71	Specify the write data storage order.	
0	Leftmost → Rightmost					
	1	Rightmost → Leftmost				
n+2	n+12	00 to 15	Processing Address	Specify the first ID Tag address to write. Setting range: 0000 to FFFA hex		
n+3	n+13	00 to 15	Number of Processing Bytes	Specify the number of ID Tag write bytes. Setting range: 0001 to 01FE hex		
n+4	n+14	00 to 15	Data storage area	Data Storage Word Address (rightmost 4 digits)  p. 71		
n+5	n+15	12 to 15		Data Storage Area		
		08 to 11		Bank Specification		
		00 to 07		Data Storage Word Address (leftmost 2 digits)		
n+6	n+16	00 to 15	Option	Command Option	Not used	



- Verification will not be performed if No Verification is set for writing.





- Check the memory capacity of the ID Tag before setting the Processing Address and Number of Processing Bytes. If the Processing Address and Number of Processing Bytes are not suitable for the ID Tag for which communications are being performed, the ID Tag Address Error Flag (CIO n+8, bit 13) will turn ON.



- The five bytes of data after the area extending from the Processing Bytes is the check code area. Do not write any data to the check code area.
- Check the memory capacity of the ID Tag before setting the Processing Address and Number of Processing Bytes. If the Processing Address and Number of Processing Bytes are not suitable for the ID Tag for which communications are being performed, the ID Tag Address Error Flag (CIO n+8, bit 13) will turn ON.



■ UID Read

Reads the ID code from the ID Tag.

Word address		Bit No.	Type	Bit name	Description
Antenna 1 of CS1W-V680C11, CS1W-V680C12, CJ1W-V680C11, or CJ1W-V680C12	Antenna 2 of CS1W-V680C12 or CJ1W-V680C12				
n+1	n+11	08 to 15	Command	Command code	0C hex
		04 to 07		Communications Specification  p. 85	Specify the communications method with the ID Tag.
				0	Trigger
				1	Single auto
				2	Repeat auto
				3	FIFO trigger
				4	FIFO repeat
				5	Multi-access trigger
		6		Multi-access repeat	
		00 to 03		Processing Specification  p. 71	Specify the read data storage order.
0	Leftmost → Rightmost				
n+2	n+12	00 to 15	Processing Address	Not used	
			n+3		n+13
n+4	n+14	00 to 15	Data storage area	Data Storage Word Address (rightmost 4 digits)  p. 71	Specify the read data storage destination.
n+5	n+15	12 to 15		Data Storage Area	
		08 to 11		Bank Specification	
		07 to 11		Data Storage Word Address (leftmost 2 digits)	
n+6	n+16	00 to 15	Option	Command Option	Not used

■ Noise Measurement

Checks the noise level when the command is received.

Word address		Bit No.	Type	Bit name	Description
Antenna 1 of CS1W-V680C11, CS1W-V680C12, CJ1W-V680C11, or CJ1W-V680C12	Antenna 2 of CS1W-V680C12 or CJ1W-V680C12				
n+1	n+11	08 to 15	Command	Command code	10 hex
		04 to 07		Communications Specification  p. 85	Not used
		00 to 03		Processing Specification	Not used
n+2	n+12	00 to 15		Processing Address	
n+3	n+13	00 to 15		Number of Processing Bytes	
n+4	n+14	00 to 15		Data storage area	Data Storage Word Address (rightmost 4 digits)  p. 71
n+5	n+15	12 to 15	Data Storage Area		
		08 to 11	Bank Specification		
		00 to 07	Data Storage Word Address (leftmost 2 digits)		
n+6	n+16	00 to 15	Option	Command Option	Not used

Communications Time

ID Tag Communications Time

V680-HA63A, V680-HS□□, V680-D1KP□□, V680-H01-V2, and V680-D1KP□□

Tag communications speed	Command	Communications time N: Number of processed bytes
Normal Mode	Read	$T = 1.3N + 31$
	Write with verification	$T = 2.1N + 58$
	Write with no verification	$T = 1.8N + 56$
High-speed Mode	Read	$T = 1.0N + 29$
	Write with verification	$T = 1.8N + 51$
	Write with no verification	$T = 1.5N + 47$

● Communications speed: Normal Mode

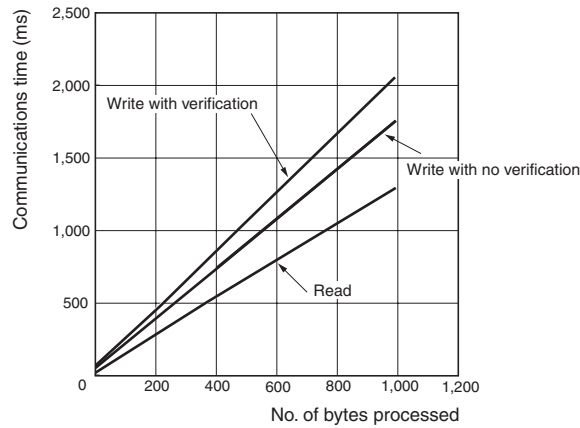

● Communications speed: High-speed Mode

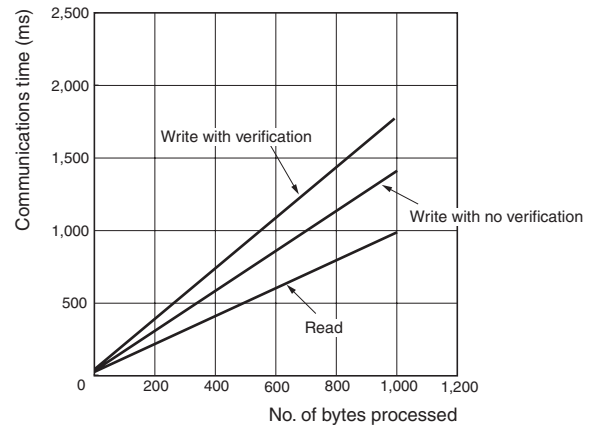

V680-HA63B, V680-HS□□, and V680-D2KF□□

Tag communications speed	Command	Communications time N: Number of processed bytes
Normal Mode	Read	$T = 1.2N + 30$
	Write with verification	$T = 2.4N + 49$
	Write with no verification	$T = 1.2N + 49$
High-speed Mode (See note.)	Read	$T = 0.9N + 27$
	Write with verification	$T = 1.7N + 49$
	Write with no verification	$T = 0.9N + 41$

Note: When using a multi-access or FIFO communications specification, the Normal Mode communications speed will be used even if the High-speed Mode is set.

● Communications speed: Normal Mode

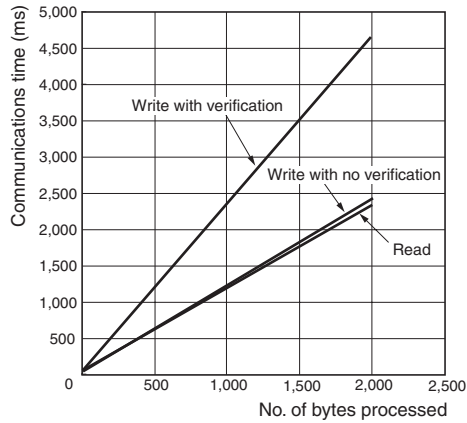

● Communications speed: High-speed Mode

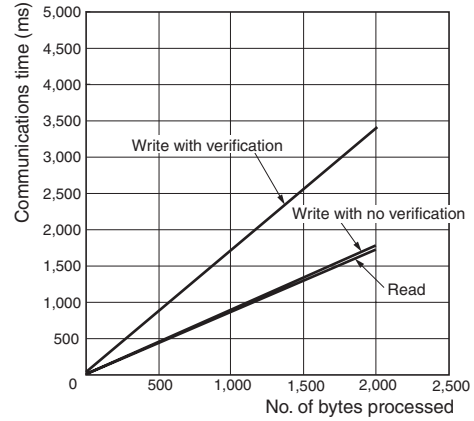

V680-HA63B, V680-HS□□, V680-D8KF□□, and V680-D32KF□□

Tag communications speed	Command	Communications time N: Number of processed bytes
Normal Mode	Read	$T = 1.3N + 30$
	Write with verification	$T = 1.6N + 59$
	Write with no verification	$T = 1.3N + 50$
High-speed Mode (See note.)	Read	$T = 0.8N + 25$
	Write with verification	$T = 1.1N + 41$
	Write with no verification	$T = 0.9N + 40$

Note: When using a multi-access or FIFO communications specification, the Normal Mode communications speed will be used even if the High-speed Mode is set.

● Communications speed: Normal Mode

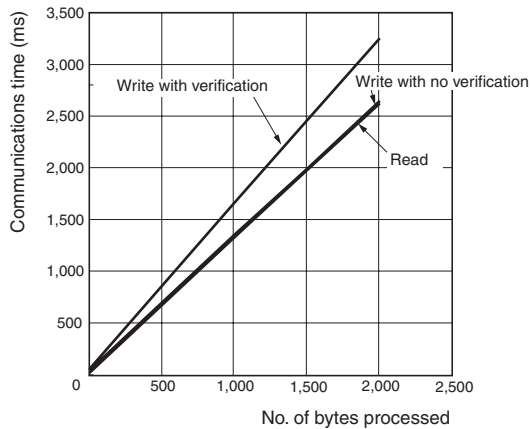

● Communications speed: High-speed Mode

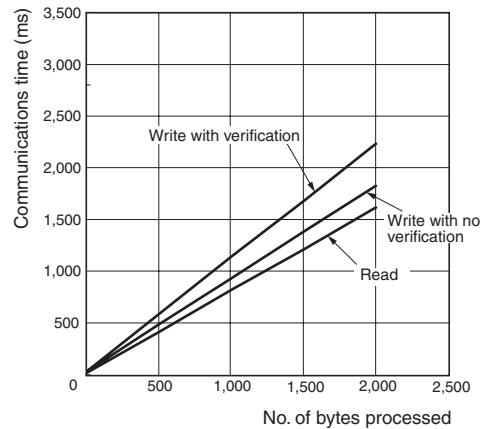

ID Tag Travel Speed

The ID Tag travel speed can be calculated using the following formula.

$$\text{Travel speed} = \text{Travel distance in communications area} / \text{communications time}$$

The communications time is given in the graphs on the previous page. The travel distance in the communications area depends on the Antenna and the ID Tag. Refer to the user manual for the Antenna and ID Tag.

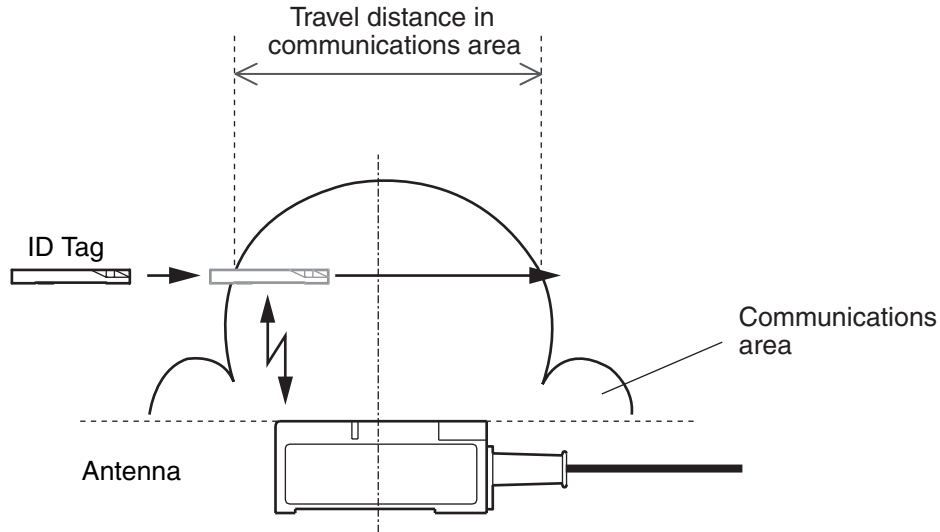

- The travel speed will change with the communications distance and axis displacement. We recommend using the widest part of the area.
- The above calculation formula is provided only as a guideline. Perform tests with the actual system before application.
- Communications error processing is not included in the above calculation formula.

■ TAT Calculation

The time from when the CS/CJ-series CPU Unit turns ON the ID Sensor Unit's Command Execution Bit until the ID Tag is communicated with and execution results are returned (i.e. the TAT, or Turnaround Time) can be calculated with the following formula.

$$\text{TAT} = \text{Coefficient} \times \text{Cycle time} + \text{Communications time}$$

Name	Description
Coefficient	(Number of Processing Bytes/160) + 3 (See note.)
Cycle time	Cycle time of the CS/CJ-series CPU Unit
Communications time	The communications time between the ID Sensor Unit and ID Tag (as previously described)

Note: Round OFF the result of the Number of Processing Bytes/160.

SECTION 7

Troubleshooting Alarms and Errors

❖ Indicators and Error Check Flowcharts	146
❖ ID Sensor Unit Alarms	148
❖ CPU Unit Errors	151
❖ Restarting Special I/O Units	152
❖ Troubleshooting	153

Indicators and Error Check Flowcharts

Status Indicators

If an alarm or error occurs in the ID Sensor Unit, the ERC indicator or ERH indicator will light on the Unit's front panel.

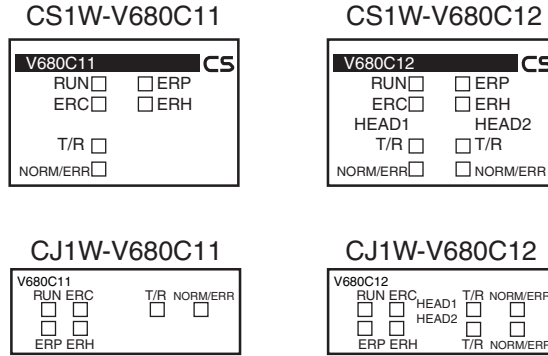

Indicator		Name	Color	Meaning	
RUN		RUN	Green	○ Lit	The ID Sensor Unit is operating normally.
				● Not lit	The ID Sensor Unit is stopped.
ERC (Error in Controller)		Unit error	Red	○ Lit	An error has occurred in the ID Sensor Unit.
				● Not lit	No error has occurred in the ID Sensor Unit.
ERH (Error at CPU Unit)		CPU Unit error	Red	○ Lit	An error has occurred in the CPU Unit.
				● Not lit	No error has occurred in the CPU Unit.
ERP (Antenna Power Error)		Antenna power error	Red	○ Lit	An error has occurred in the power supply to the Antenna.
				● Not lit	The power supply to the Antenna is normal.
HEAD1 (Antenna 1)	T/R	Communicating	Yellow	○ Lit	Communications are active.
				● Not lit	Communications not being performed with the ID Tag.
	NORM/ERR	Normal end	Green	○ Lit	Communications with the ID Tag ended normally.
				● Not lit	The indicator is not lit in all other cases.
		Error end	Red	○ Lit	Communications with the ID Tag ended in an error.
				● Not lit	The indicator is not lit in all other cases.
HEAD2 (Antenna 2)	T/R	Communicating	Yellow	○ Lit	Communications are active.
				● Not lit	Communications not being performed with the ID Tag.
	NORM/ERR	Normal end	Green	○ Lit	Communications with the ID Tag ended normally.
				● Not lit	The indicator is not lit in all other cases.
		Error end	Red	○ Lit	Communications with the ID Tag ended in an error.
				● Not lit	The indicator is not lit in all other cases.

Error Check Flowchart

Use the following flowchart to check the error if an error occurs in the ID Sensor Unit.

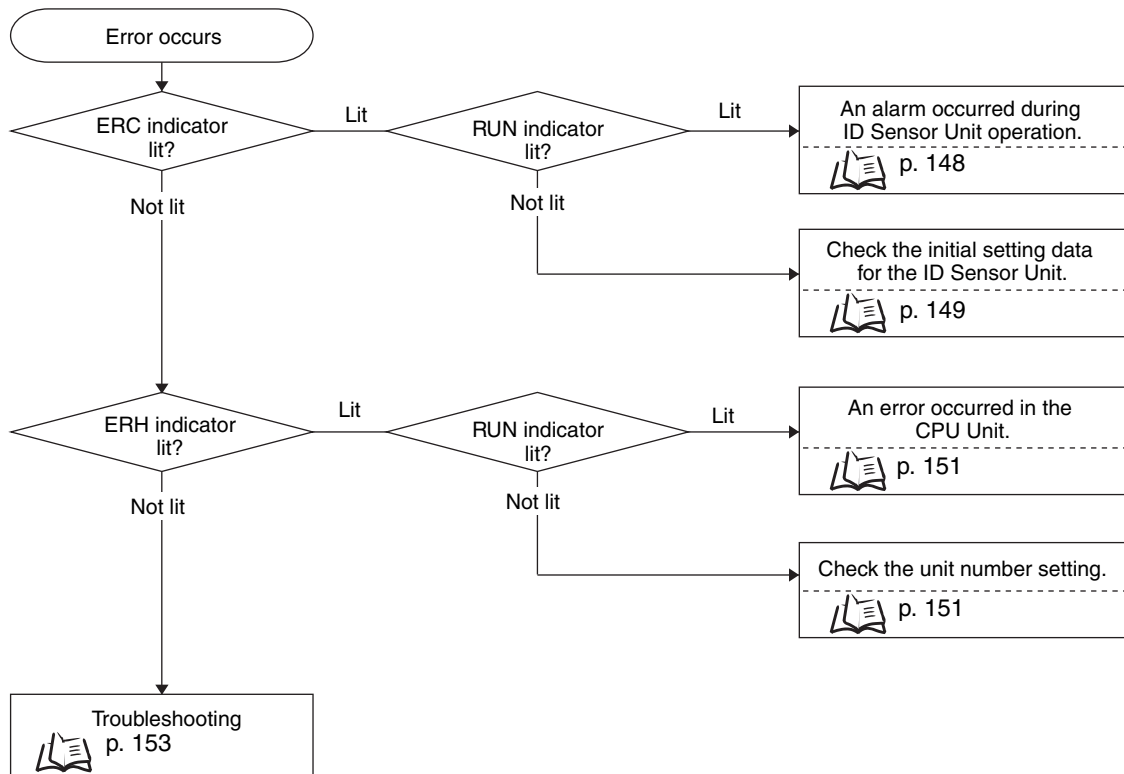

ID Sensor Unit Alarms

The ERC indicator will light when the ID Sensor Unit detects an alarm. The relevant Alarm Flag will be turned on in the Unit Status (CIO n+7) (and, for a Two-channels ID Sensor Unit, (CIO n+17)) in the Special I/O Unit Area.

I/O	Word address		Bit No.	Type	Bit name	Description
	Antenna 1 of CS1W-V600C11, CS1W-V600C12, CJ1W-V600C11, or CJ1W-V600C12	Antenna 2 of CS1W-V600C12 or CJ1W-V600C12				
Input	n+7	n+17	15	Unit Status	Unit Busy Flag	Turns ON when there is an ID Sensor Unit error.
			14		Test Mode Flag	Turns ON during Test Mode.
			13		Antenna Power Supply Error Flag	Turns ON when there is an error in the Unit's power supply or the external power supply.
			12		EEPROM error	Turns ON when there is an error in reading EEPROM.
			11		Antenna Error Flag	The DM Area setting and V680-H01 Antenna connection status do not match. Too many Antennas are connected or the specified power consumption has been exceeded.
			03 to 10		---	Not used
			02		Error End Flag	Turns ON for one scan when processing ends in an error.
			01		Normal End Flag	Turns ON for one scan when processing ends normally.
			00		ID Busy Flag	Turns ON while communications are in progress.

Both ERC and RUN Indicators Lit

CS1W-V680C11

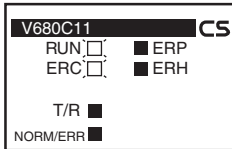

CS1W-V680C12

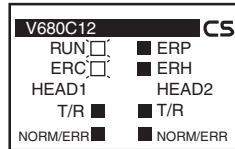

CJ1W-V680C11

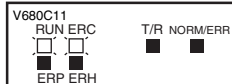

CJ1W-V680C12

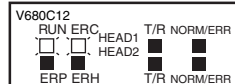

Lit:
Not Lit:

If both the ERC and RUN indicators are lit, an alarm occurred during Unit operation.

The Unit Busy Flag in the Unit Status (CIO n+7) (for a Two-channels ID Sensor Unit, CIO n+17 for Antenna 2) will turn ON.

The Unit will recover from this alarm automatically when the cause of the alarm is removed.

Word address		Name of alarm	Meaning	Unit response	Correction
Antenna 1 of CS1W-V600C11, CS1W-V600C12, CJ1W-V600C11, or CJ1W-V600C12)	Antenna 2 of CS1W-V600C12 or CJ1W-V600C12				
n+7	n+17				
Bit 15		ID Sensor Unit CPU Error Flag	A CPU error occurred during ID Sensor Unit operation	Unit operation will stop.	<ul style="list-style-type: none"> Turn the power supply OFF and ON or turn ON the Special I/O Unit Restart Bit. Replace the ID Sensor Unit if the error persists even though the Unit is reset.



- First word allocated to Unit in CIO Area: $n = \text{CIO } 2000 + 10 \times \text{Unit number}$

■ ERC Indicator Lit and RUN Indicator Not Lit

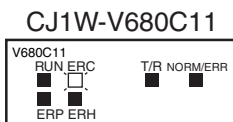
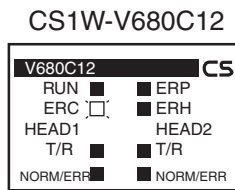
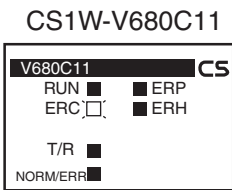

Lit: □
Not lit: ■

If the ERC indicator is lit and the RUN indicator is not lit, an alarm occurred in the ID Sensor Unit immediately after the power supply was turned ON or immediately after the Unit was restarted as a Special I/O Unit.

The Alarm Flags in the Unit Status (CIO n+7) (for a Two-channels ID Sensor Unit, (CIO n+17) for Antenna 2) will turn ON.

Word address		Name of alarm	Meaning	Unit response	Correction
Antenna 1 of CS1W-V600C11, CS1W-V600C12, CJ1W-V600C11, or CJ1W-V600C12)	Antenna 2 of CS1W-V600C12 or CJ1W-V600C12)				
n+7	n+17				
Bit 15		ID Sensor Unit CPU Error Flag	An error occurred in the ID Sensor Unit when the power supply was turned ON or immediately after the Unit was restarted.	Unit operation will stop.	<ul style="list-style-type: none"> Turn the power supply OFF and ON or turn ON the Special I/O Unit Restart Bit. Replace the ID Sensor Unit if the error persists even though the Unit is reset.
Bit 12		EEPROM Error Flag	An error occurred when memory read was read.	Unit operation will stop.	<ul style="list-style-type: none"> Turn the power supply OFF and ON or turn ON the Special I/O Unit Restart Bit. Replace the ID Sensor Unit if the error persists even though the Unit is reset.



• First word allocated to Unit in CIO Area: $n = \text{CIO } 2000 + 10 \times \text{Unit number}$

SECTION 7 Troubleshooting Alarms and Errors

Error name	Word (CIO n+8) (CIO n+18 (See note.2))	Word (CIO n+9) (CIO n+19 (See note.2))	Error	Correction
ID Tag Communications Error Flag	Bit 12	E070	An error occurred in communications with a ID Tag, preventing a normal end.	<ul style="list-style-type: none"> • Check for excessive noise. • Check the travel speed. • Check the distance between the Antenna and ID Tag.
Verification Error Flag	Bit 14	E071	The correct data could not be written to the ID Tag. (Occurs only when verification is set for a write operation.)	<ul style="list-style-type: none"> • Check the travel speed. (Page 143) • Check for excessive noise.
ID Tag Missing Error Flag	Bit 10	E072	<ul style="list-style-type: none"> • The communications specification was for a trigger, but there was no ID Tag in the communications area. • The communications specification was for single auto, but the Auto Wait Time expired. 	<ul style="list-style-type: none"> • The Antenna and ID Tag are too far apart. • The axis is out of alignment.
ID System Error 1	Bit 09	E079	System error	Please consult your OMRON representative.
ID System Error 2	Bit 08	E07E	System error	Please consult your OMRON representative.
ID System Error 3	Bit 07	E07F	System error	Please consult your OMRON representative.
Status Flag	Bit 04	E076	<ul style="list-style-type: none"> • An overflow or underflow occurred for a Calculation Write command. • The data did not verify for a Data Check command. • The number of writes was exceeded for a Number of Writes Control command. • An error occurred in the data for a Read with Error Correction command. 	<ul style="list-style-type: none"> • Check the data settings. • Replace the ID Tag.
			<ul style="list-style-type: none"> • An error occurred while writing for a Copy command. 	(See note.1)
ID Tag Address Error Flag	Bit 13	E07A	The ID Tag address specified in the command is not correct.	<ul style="list-style-type: none"> • Specify the address correctly.
Antenna Error Flag	Bit 15	E07C	An Antenna error occurred.	<ul style="list-style-type: none"> • Check 24 VDC input. (CS1W-V680C12 only) • Check the Antenna.
Write Protection Error Flag	Bit 11	E07D	An attempt was made to write to a write-protected area.	<ul style="list-style-type: none"> • Specify the address and number of bytes correctly. • Clear write protection. (Page 95)
Error Correction Flag	Bit 03	E077	Read with Error Correction performed a 1-bit error correction.	---
Data Storage Area Specification Error Flag	Bit 01	E014	The data storage area specification is not correct.	Specify the data storage area specification correctly.
Command Error Flag	Bit 00	E014	The command to the ID Sensor Unit is not correct.	Specify the command correctly.

Note 1: The following errors may occur while writing for a Copy command. Confirm the steps to handle each error.

- ID Tag communications error
- ID Tag verification error
- ID Tag missing error
- ID Tag address error
- Antenna error
- Write protection error

Note 2: CIO n+8, CIO n+9 are error information of Antenna 1 (Head No.1).
CIO n+18, CIO n+19 are error information of Antenna 2 (Head No.2).

CPU Unit Errors

The ERH indicator will light when the ID Sensor Unit cannot operate because an error occurred on the I/O bus to the CPU Unit or when data cannot be refreshed as a Special I/O Unit.

Both ERH and RUN Indicators Lit

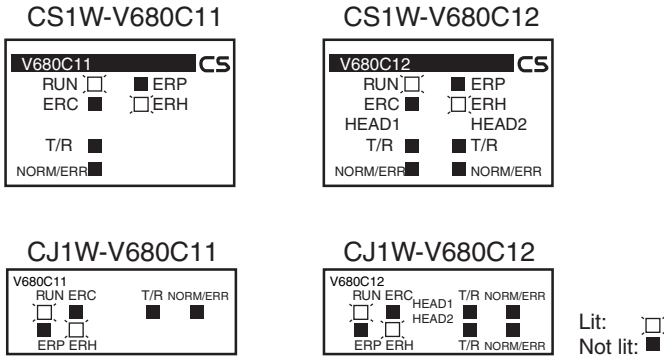

The ERH and RUN indicators will light when an error occurs on the I/O bus or a WDT (watchdog timer) error occurs in the CPU Unit, preventing data from being correctly refreshed for the ID Sensor Unit as a Special I/O Unit. If this happens, either turn the power supply OFF and ON or restart the system. Refer to the *SYSMAC CS/CJ-series Programmable Controllers Operation Manual* for details.

Error name	Error	Unit response
I/O bus error	An error occurred in data transfer between the CPU Unit and the ID Sensor Unit.	Unit operation will stop.
CPU Unit monitor error	An error occurred because there was no response from the CPU Unit.	
CPU Unit WDT error	An error occurred in the CPU Unit.	

ERH Indicator Lit and RUN Indicator Not Lit

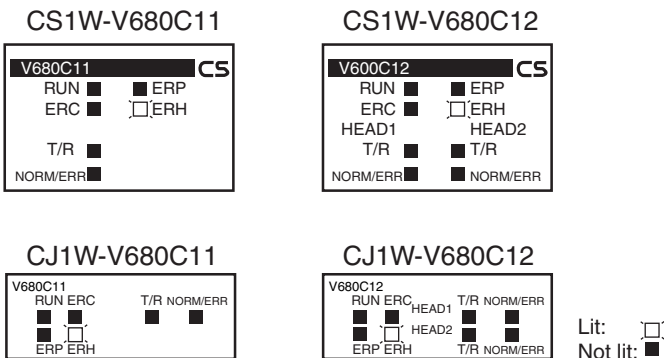

There is an error in the unit number setting for the ID Sensor Unit.

Error name	Error	Unit response
Unit number duplication	The same unit number is set for more than one Unit or was set to a value that is not between 00 and 95.	Unit operation will stop.
Special I/O Unit setting error	The model of Special I/O Unit registered in the I/O table does not agree with the model of Special I/O Unit mounted in the system.	

Restarting Special I/O Units

To restart operation after changing settings in the DM Area or after removing the cause of an error, either turn the PLC's power supply OFF and ON or turn ON the Special I/O Unit Restart Bit.

• CS-series Special I/O Unit Restart Bits

Bit address	Function	
A50200	Unit 0 Restart Bit	The Unit will be restarted when the corresponding bit is turned ON. After the Unit has finished restarting, the corresponding bit will be automatically turned OFF.
A50201	Unit 1 Restart Bit	
⋮	⋮	
A50215	Unit 15 Restart Bit	
A50300	Unit 16 Restart Bit	
⋮	⋮	
A50715	Unit 95 Restart Bit	

• CJ-series Special I/O Unit Restart Bits

Bit address	Function	
A50200	Unit 0 Restart Bit	The Unit will be restarted when the corresponding bit is turned ON. After the Unit has finished restarting, the corresponding bit will be automatically turned OFF.
A50201	Unit 1 Restart Bit	
⋮	⋮	
A50215	Unit 15 Restart Bit	
A50300	Unit 16 Restart Bit	
⋮	⋮	
A50715	Unit 95 Restart Bit	



CHECK!

- If an error persists even though the power supply is turned OFF and ON or the Special I/O Unit Restart Bit is turned ON, replace the ID Sensor Unit, Power Supply Unit, or CPU Unit.

Troubleshooting

Main Check Flowchart

Use the Main Check Flowchart according to the nature of the error.

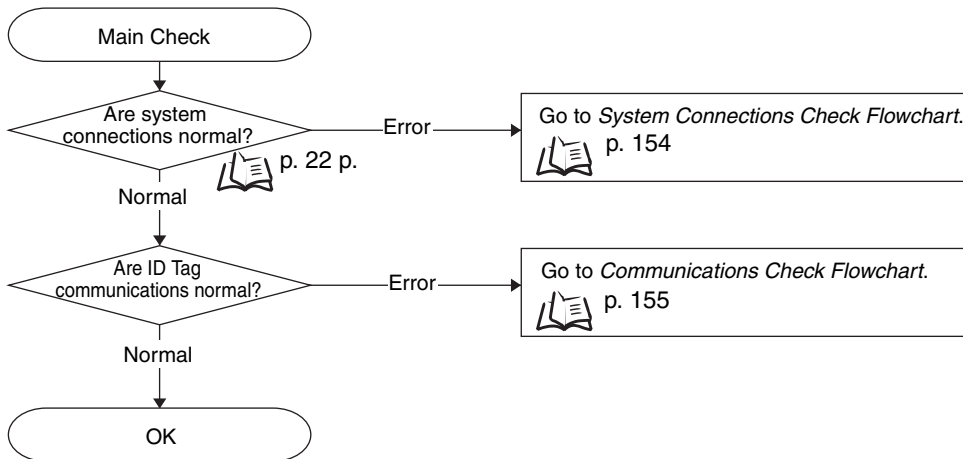

System Connections Check Flowchart

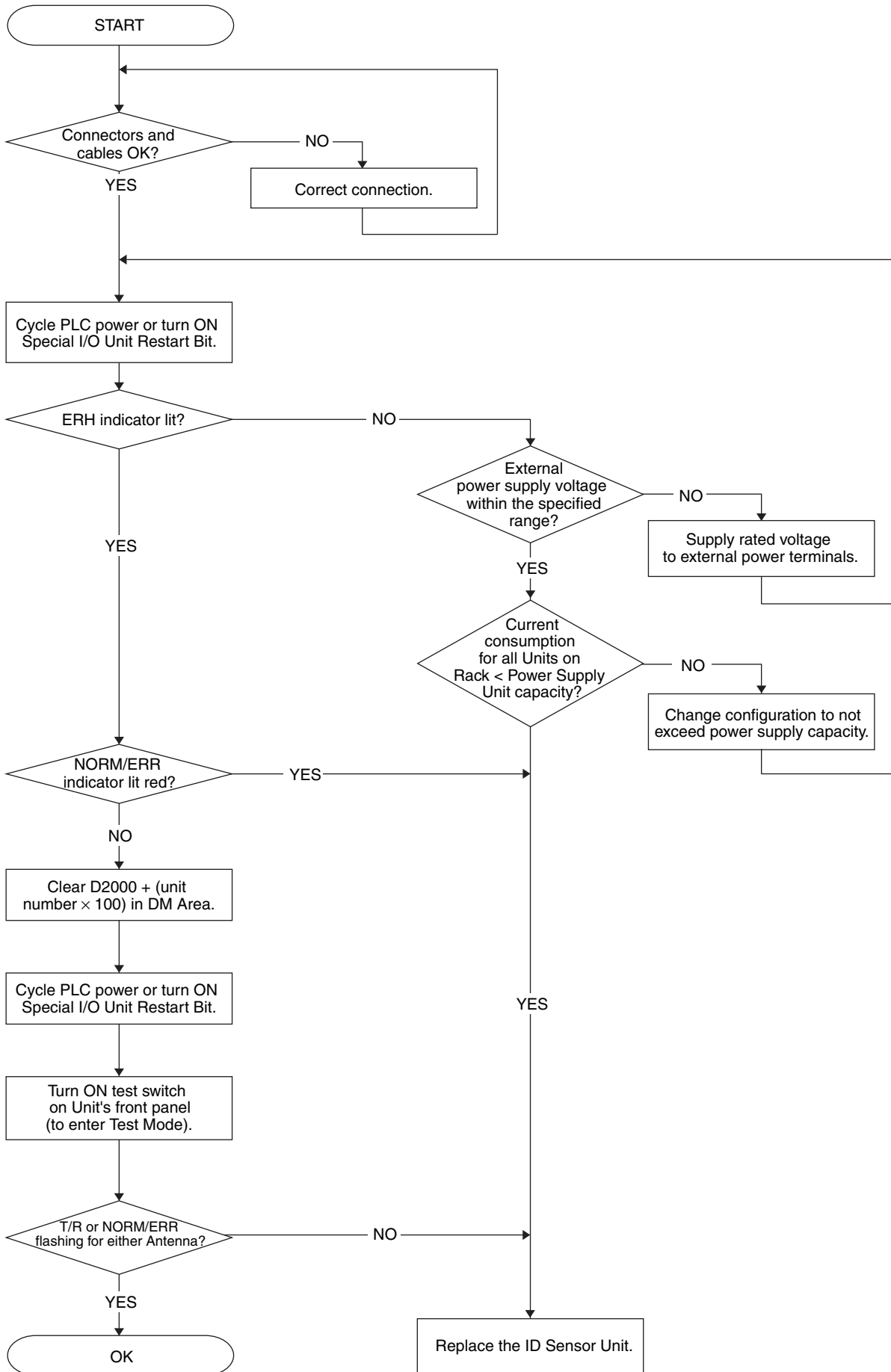

Communications Check Flowchart

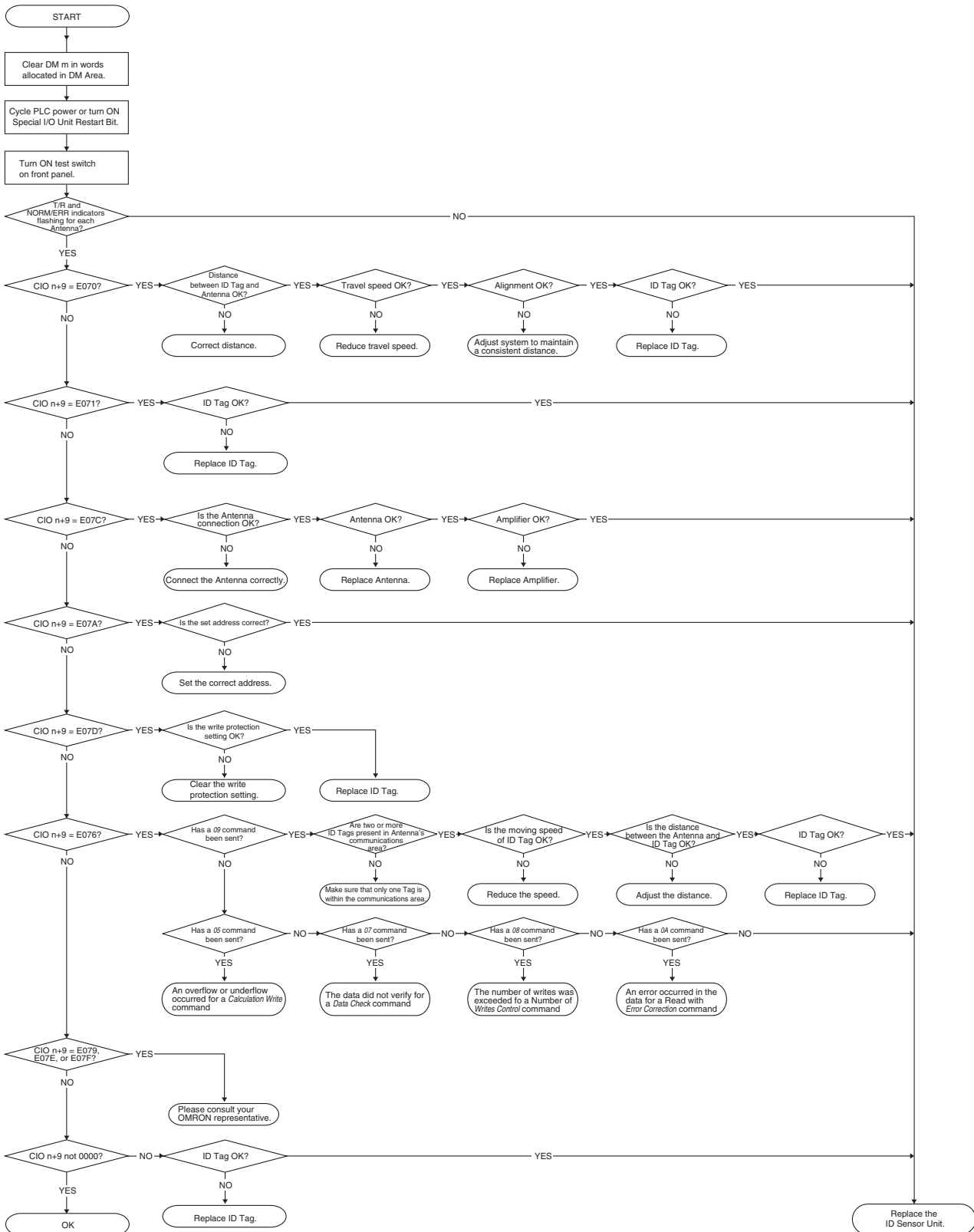

- First word allocated to Unit in DM Area: $m = D20000 + 100 \times \text{Unit number}$
- First word allocated to Unit in CIO Area: $n = \text{CIO } 2000 + 10 \times \text{Unit number}$

MEMO

SECTION 8

Appendices

☒ Dimensions	158
☒ Sample Programming	160
☒ Data Coding Tables	204
☒ Degree of Protection	208

Dimensions

CS1W-V680C11

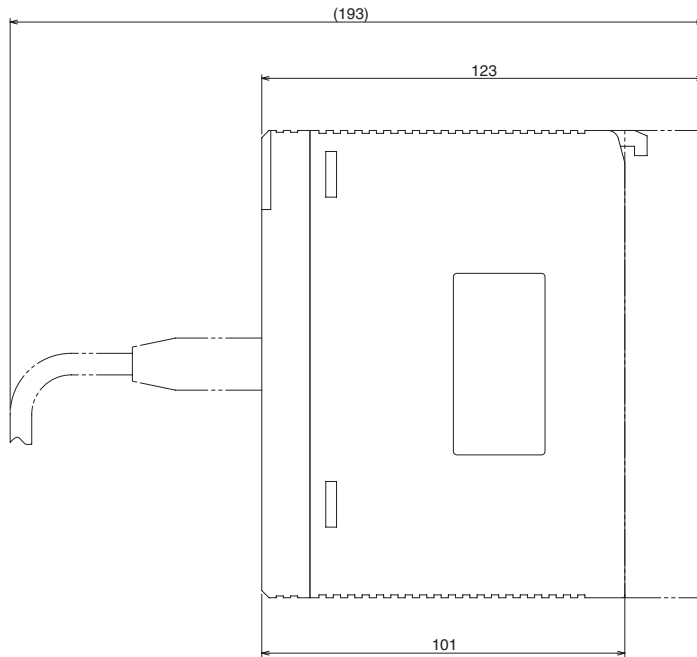
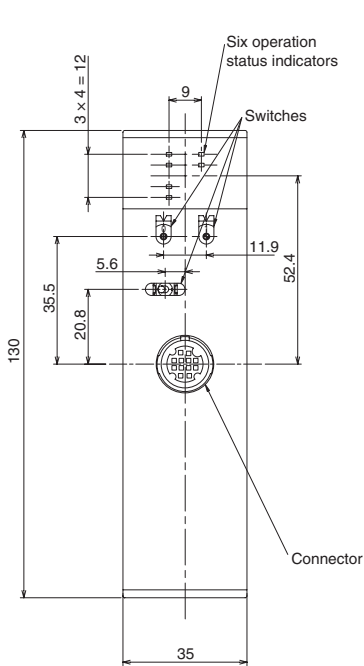

CS1W-V680C12

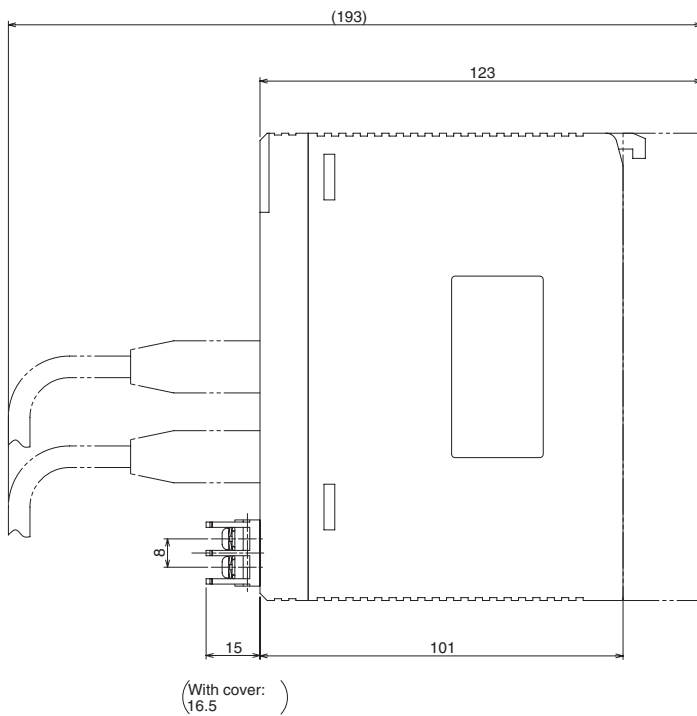
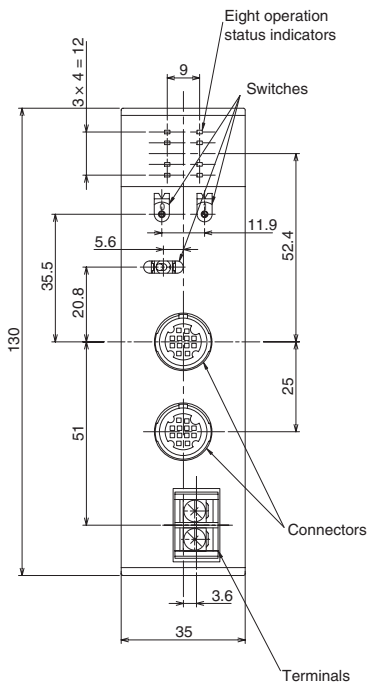

CJ1W-V680C11

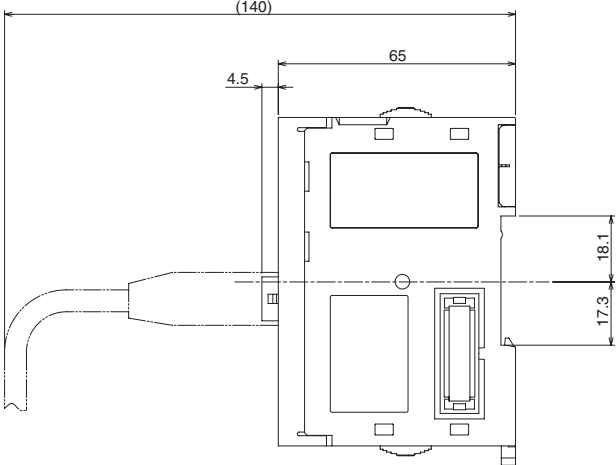
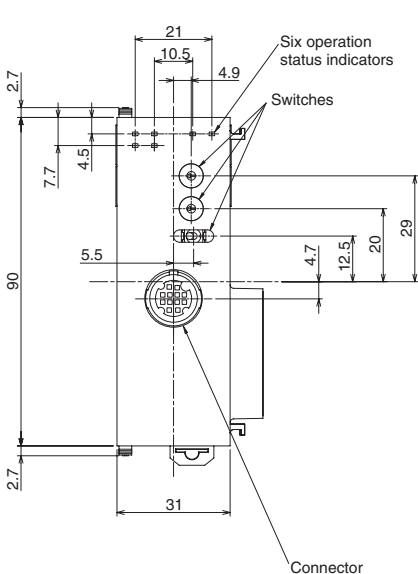

CJ1W-V680C12

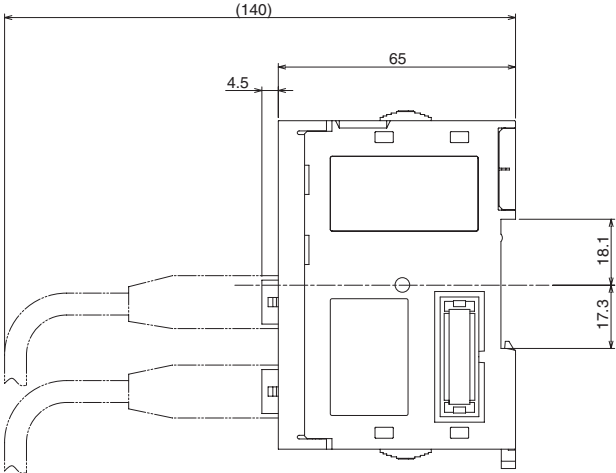
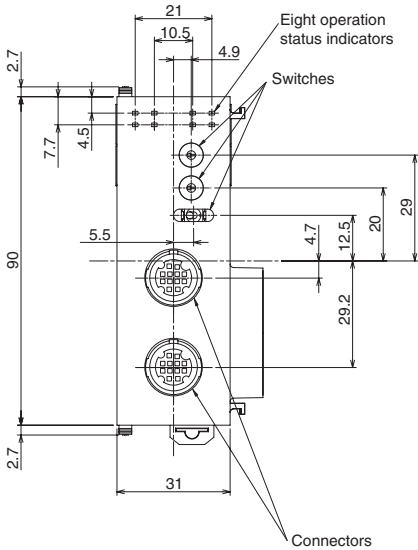

Sample Programming

Read, Communications Specification: Trigger

• Outline

This example shows how to read the memory of an ID Tag that is present in the communications area for Antenna 1.

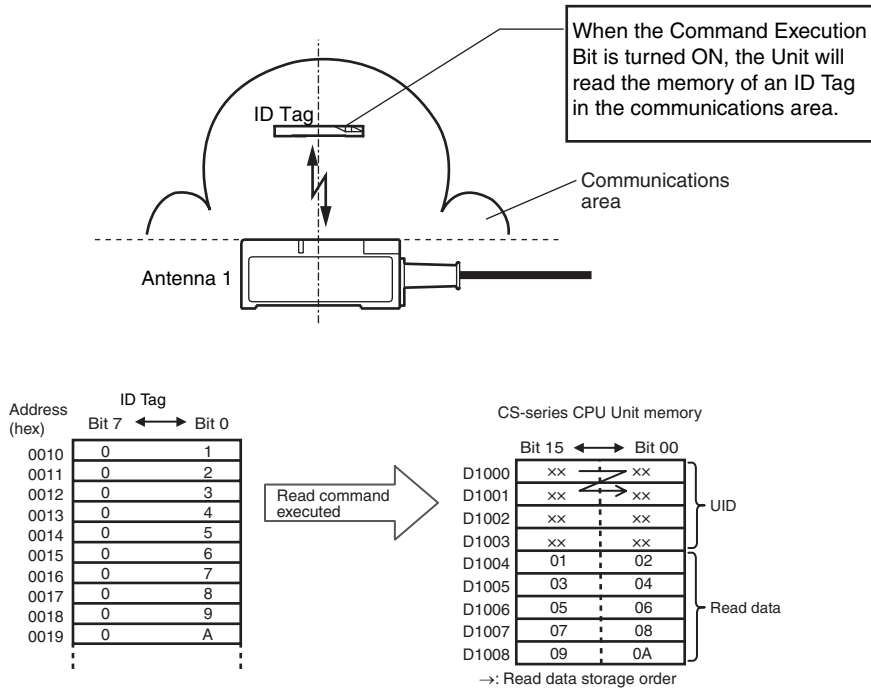

Unit Settings

Item	Setting	Setting location
Unit number	00	Unit's front panel unit number switches: 00
Operating mode	Run Mode	Unit's front panel test switch: OFF
System Settings	UID Addition Setting: Enabled Test Mode Disable Setting: Enabled Setting for Write Verification: Verification Tag Communications Speed Setting: Normal Mode Data transfer setting: Cyclic	Set in the Special I/O Unit words in DM Area.
Auto Wait Time Setting	Infinite	
Command	Read	Set in the Special I/O Unit Area.
Communications specification	Trigger	
Read data storage order	Leftmost → Rightmost	
Read start address	0010 hex	
Number of bytes to read	10 bytes	
Read data storage destination	D1000 to D1004	

First word allocated to Unit in DM Area: $m = D20000 + (100 \times 0) = D20000$

DM address	Contents				Meaning															
					15	14	13	12	11	10	9	8	7	6	5	4	3	2	1	0
D20000	1	0	0	0	UID Addition Setting				Test Mode Disable Setting				Setting for Write Verification				Tag Communications Speed Setting			
D20001	0000				Auto Wait Time Setting															

First word allocated to Unit in CIO Area: $n = CIO\ 2000 + (10 \times 0) = CIO\ 2000$

Word address	Contents				Meaning															
					15	14	13	12	11	10	9	8	7	6	5	4	3	2	1	0
CIO 2001	0	0	0	0	Command code								Communications specification				Data order			
CIO 2002	00		10		First read address															
CIO 2003	00		0A		Number of read bytes															
CIO 2004	10		00		Read data storage location (rightmost 4 digits)															
CIO 2005	0	0	00		Data storage area				Bank specification (Always 0)				Read data storage location (leftmost 2 digits)							
CIO 2006	00		00		---															

---: Ignored.

• **Programming Example**

When the execution input turns ON, settings are made in the Special I/O Unit Area using the MOV and MOVL instructions and the command is executed. When communications with the ID Tag have been completed, the Normal End Flag (CIO n+7, bit 01) or Error End Flag (CIO n+7, bit 02) is turned ON. Read data can be used after the Normal End Flag (CIO n+7, bit 01) has been turned ON. To end command execution while waiting for the ID Tag, turn ON the Abort Input.

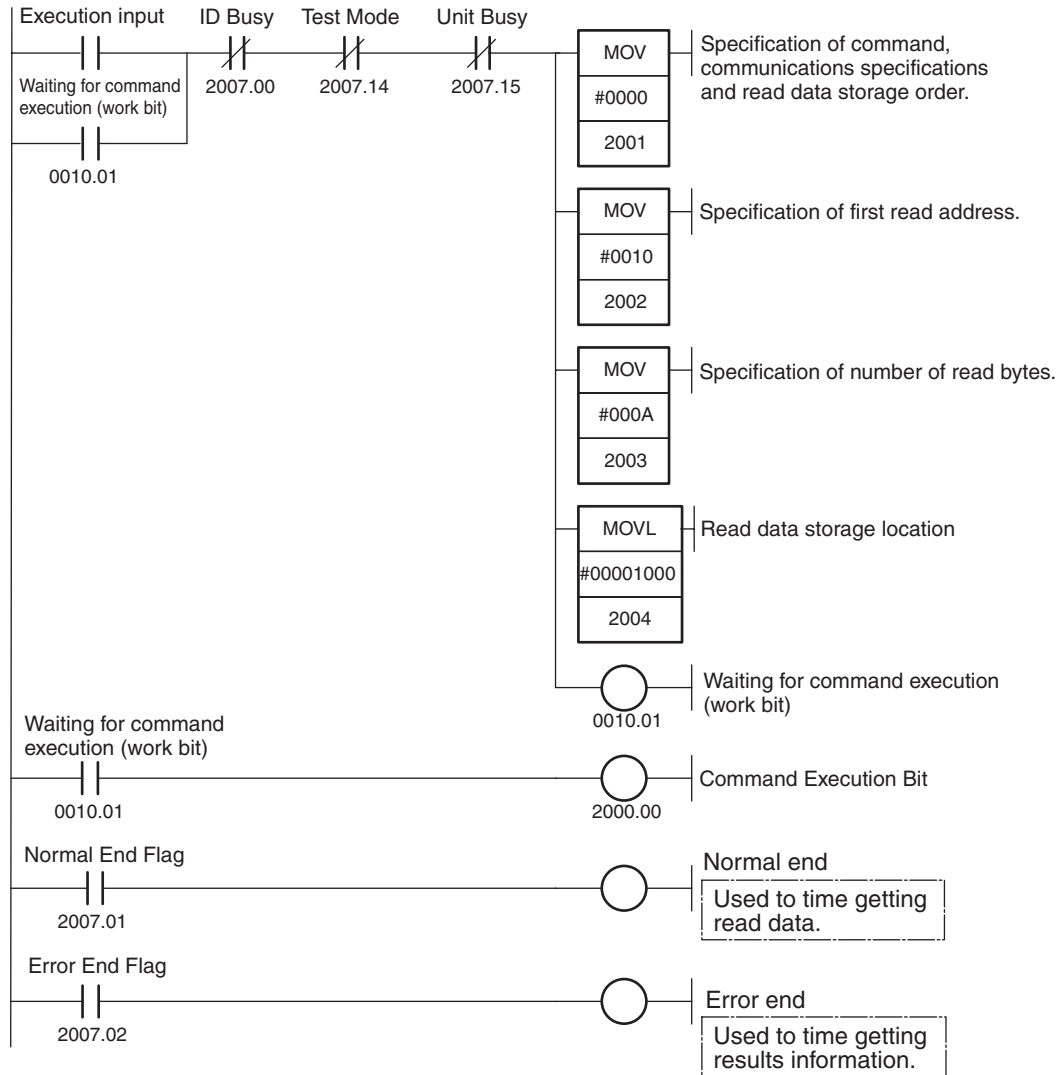

• Timing Chart (CIO n = CIO 2000 + (10 x 0) = CIO 2000)

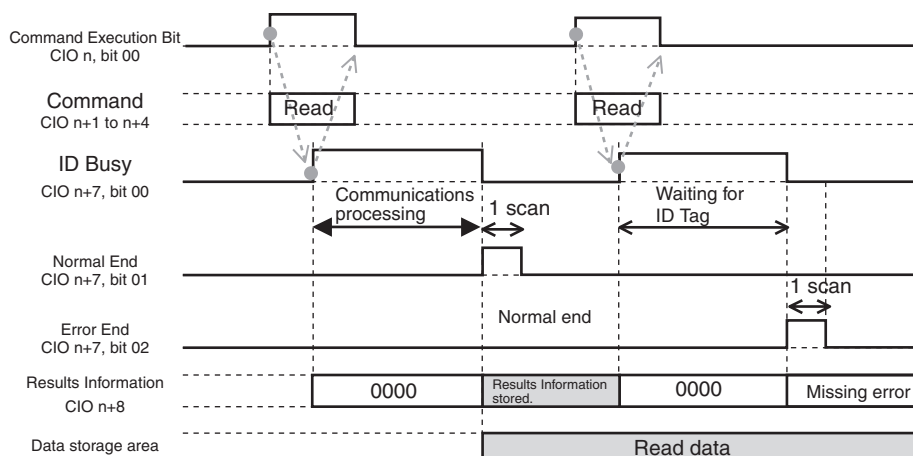

- If communications with the ID Tag fail or an error occurs, communications will be aborted at that point, the error flags in the Results Information (CIO n+8) will turn ON accordingly, and the error code will be placed in the Processing Results Monitor (CIO n+9). The previous read data will not be changed.
- To confirm the execution results from the user program, use the ON status of the Normal End Flag or Error End Flag in the Unit Status.
- Do not turn ON the Command Execution Bit during command execution (i.e., while the ID Busy Flag is ON). It will be ignored.

Read, Communications Specification: Trigger, Data Transfer: Intelligent I/O Instructions

• Outline

This example shows how to read the memory of an ID Tag that is present in the communications area for Antenna 1.

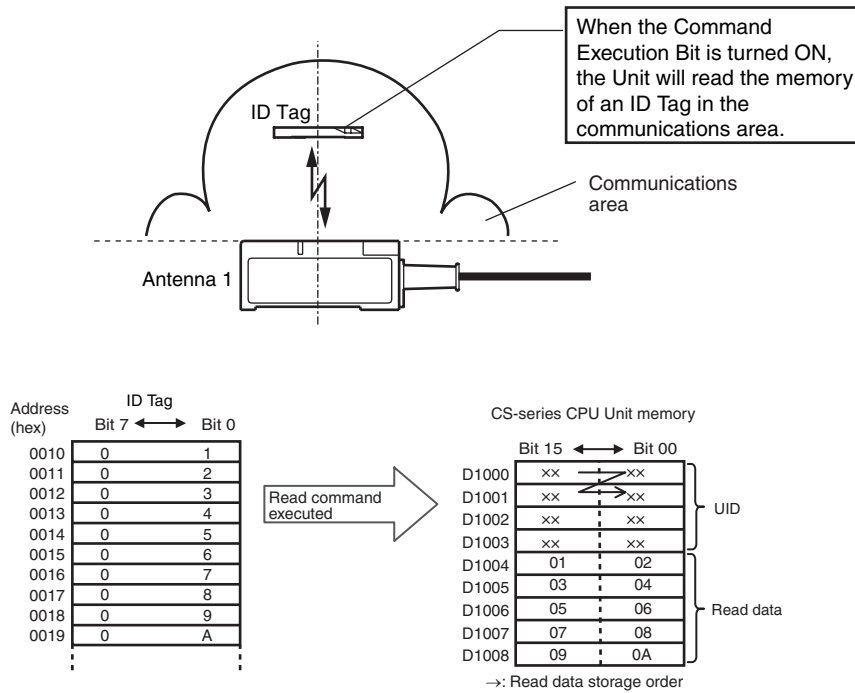

Unit Settings

Item	Setting	Setting location
Unit number	00	Unit's front panel unit number switches: 00
Operating mode	Run Mode	Unit's front panel test switch: OFF
System Settings	UID Addition Setting: Disabled Test Mode Disable Setting: Enabled Setting for Write Verification: Verification Tag Communications Speed Setting: Normal Mode Data Transfer Setting: Intelligent I/O Instructions	Set in the Special I/O Unit words in DM Area.
Auto Wait Time Setting	Infinite	
Command	Read	Set in the Special I/O Unit Area.
Communications specification	Trigger	
Read data storage order	Leftmost → Rightmost	
Read start address	0020 hex	
Number of bytes to read	512 bytes	Set in IORD instruction.
Read data storage destination	D20920 to D21431	

First word allocated to Unit in DM Area: $m = D20000 + (100 \times 0) = D20000$

DM address	Contents				Meaning															
					15	14	13	12	11	10	9	8	7	6	5	4	3	2	1	0
D20000	1	0	0	0	UID Addition Setting				Test Mode Disable Setting				Setting for Write Verification				Tag Communications Speed Setting			
D20001	0000				Auto Wait Time Setting															
D20090	0001				Data Transfer Setting															

First word allocated to Unit in CIO Area: $n = CIO 2000 + (10 \times 0) = CIO 2000$

Word address	Contents				Meaning															
					15	14	13	12	11	10	9	8	7	6	5	4	3	2	1	0
CIO 2001	0	0	0	0	Command code								Communications specification				Data order			
CIO 2002	00		10		Read start address															
CIO 2003	00		0A		Number of bytes to read															
CIO 2004	10		00		---															
CIO 2005	00		00		---															
CIO 2006	00		00		---															

---: Ignored.

• Programming Example

The following ladder programming uses the Read command and the IORD instruction to read 512 bytes of data. The IORD instruction is executed twice to read 256 bytes (128 words) each time. When the execution input turns ON, settings are made in the Special I/O Unit Area using MOV instructions and the command is executed. When communications with the ID Tag have been completed, the Normal End Flag (CIO n+7, bit 01) or Error End Flag (CIO n+7, bit 02) is turned ON. The IORD instruction is executed after the Normal End Flag (CIO n+7, bit 01) turns ON. To end command execution while waiting for the ID Tag, turn ON the Abort Input.

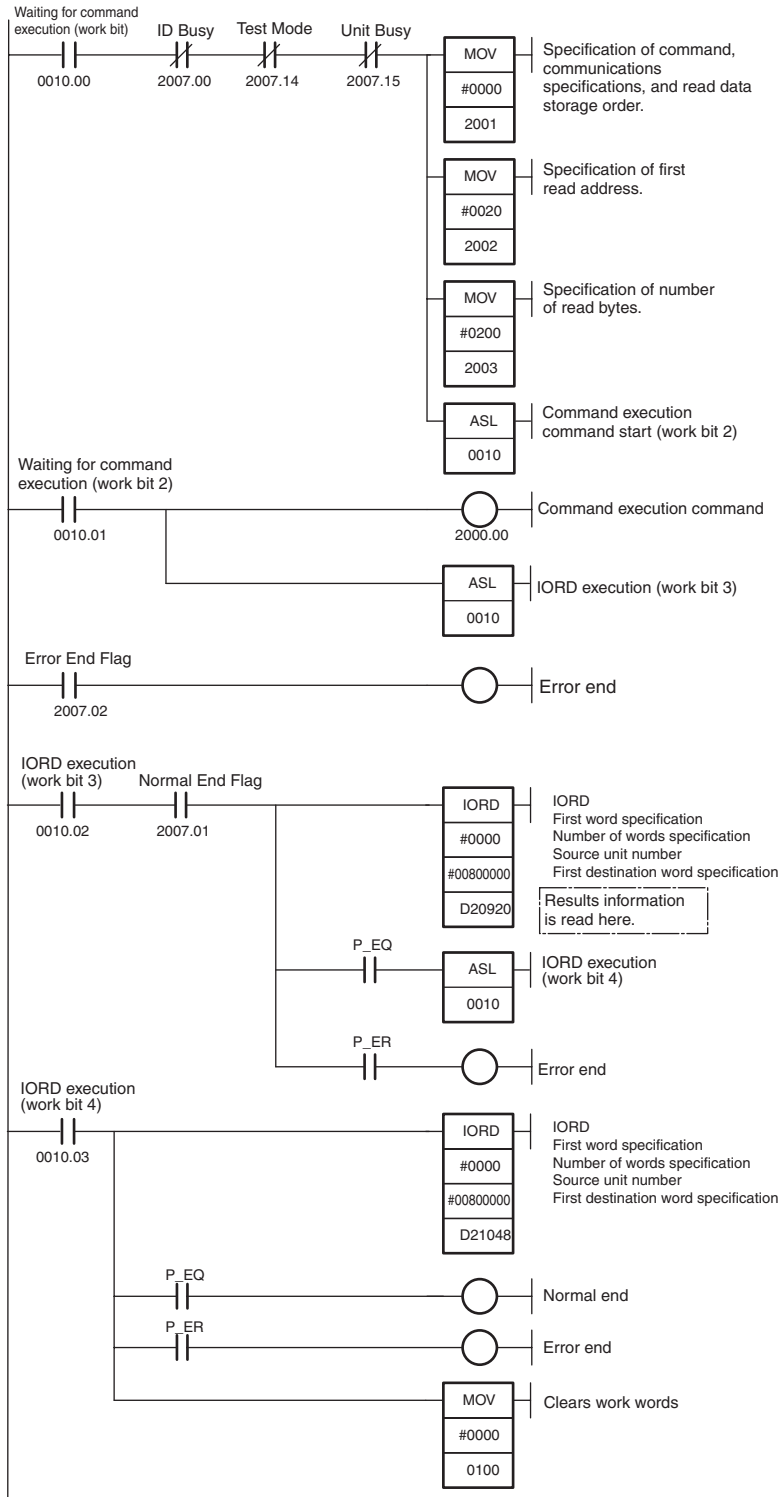

• **Timing Chart (CIO n = CIO 2000 + (10 x 0) = CIO 2000)**

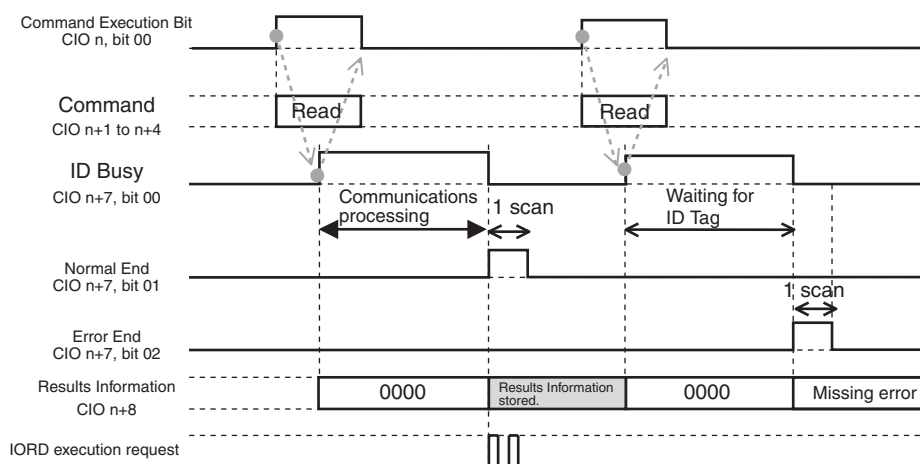

- If communications with the ID Tag fail, the bits in the Results Information (CIO n+8) will turn ON accordingly, and the error code will be placed in the Processing Results Monitor (CIO n+9). The previous read data will not be changed.
- To confirm the execution results from the user program, use the ON status of the Normal End Flag or Error End Flag. These flags show the Unit status.
- Do not turn ON the Command Execution Bit during command execution (i.e., while the ID Busy Flag is ON). It will be ignored.
- Execute the IORD instruction after the Normal End Flag turns ON.

Read, Communications Specification: Single Auto

• Outline

This example shows how to read the memory of an ID Tag as it enters the communications area for Antenna 1.

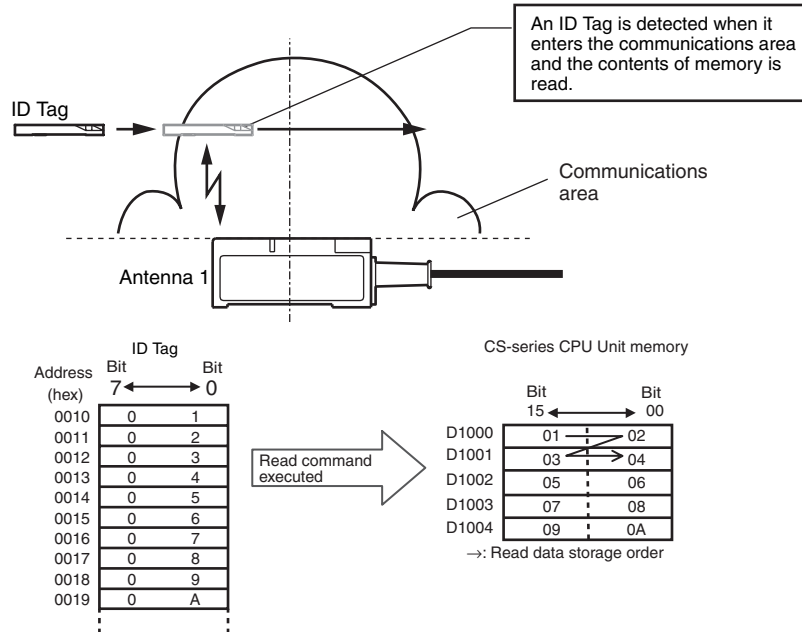

• Unit Setting Example

Item	Setting	Setting location
Unit number	00	Unit's front panel unit number switches: 00
Operating mode	Run Mode	Unit's front panel test switch: OFF
System Settings	UID Addition Setting: Disabled Test Mode Disable Setting: Enabled Setting for Write Verification: Verification Tag Communications Speed Setting: Normal Mode	Set in the Special I/O Unit words in DM Area.
Auto Wait Time Setting	Infinite	
Command	Read	Set in the Special I/O Unit Area.
Communications specification	Single auto	
Read data storage order	Leftmost → Rightmost	
Read start address	0010 hex	
Number of bytes to read	10 bytes	
Read data storage destination	D1000 to D1004	

First word allocated to Unit in DM Area: $m = D20000 + (100 \times 0) = D20000$

DM address	Contents				Meaning															
					15	14	13	12	11	10	9	8	7	6	5	4	3	2	1	0
D20000	0	0	0	0	UID Addition Setting				Test Mode Disable Setting				Setting for Write Verification				Tag Communications Speed Setting			
D20001	0000				Auto Wait Time Setting															

First word allocated to Unit in CIO Area: $n = CIO\ 2000 + (10 \times 0) = CIO\ 2000$

Word address	Contents				Meaning															
					15	14	13	12	11	10	9	8	7	6	5	4	3	2	1	0
CIO 2001	0	0	1	0	Command code								Communications specification				Data order			
CIO 2002	00		10		First read address															
CIO 2003	00		0A		Number of read bytes															
CIO 2004	10		00		Read data storage location (rightmost 4 digits)															
CIO 2005	0	0	00		Data storage area				Bank specification (Always 0)				Read data storage location (leftmost 2 digits)							
CIO 2006	00		00		---															

---: Ignored.

• **Programming Example**

When the execution input turns ON, settings are made in the Special I/O Unit Area using the MOV and MOVL instructions and the command is executed. When communications with the ID Tag have been completed, the Normal End Flag (CIO n+7, bit 01) or Error End Flag (CIO n+7, bit 02) is turned ON. Read data can be used after the Normal End Flag (CIO n+7, bit 01) has been turned ON. To end command execution while waiting for the ID Tag, turn ON the Abort Input.

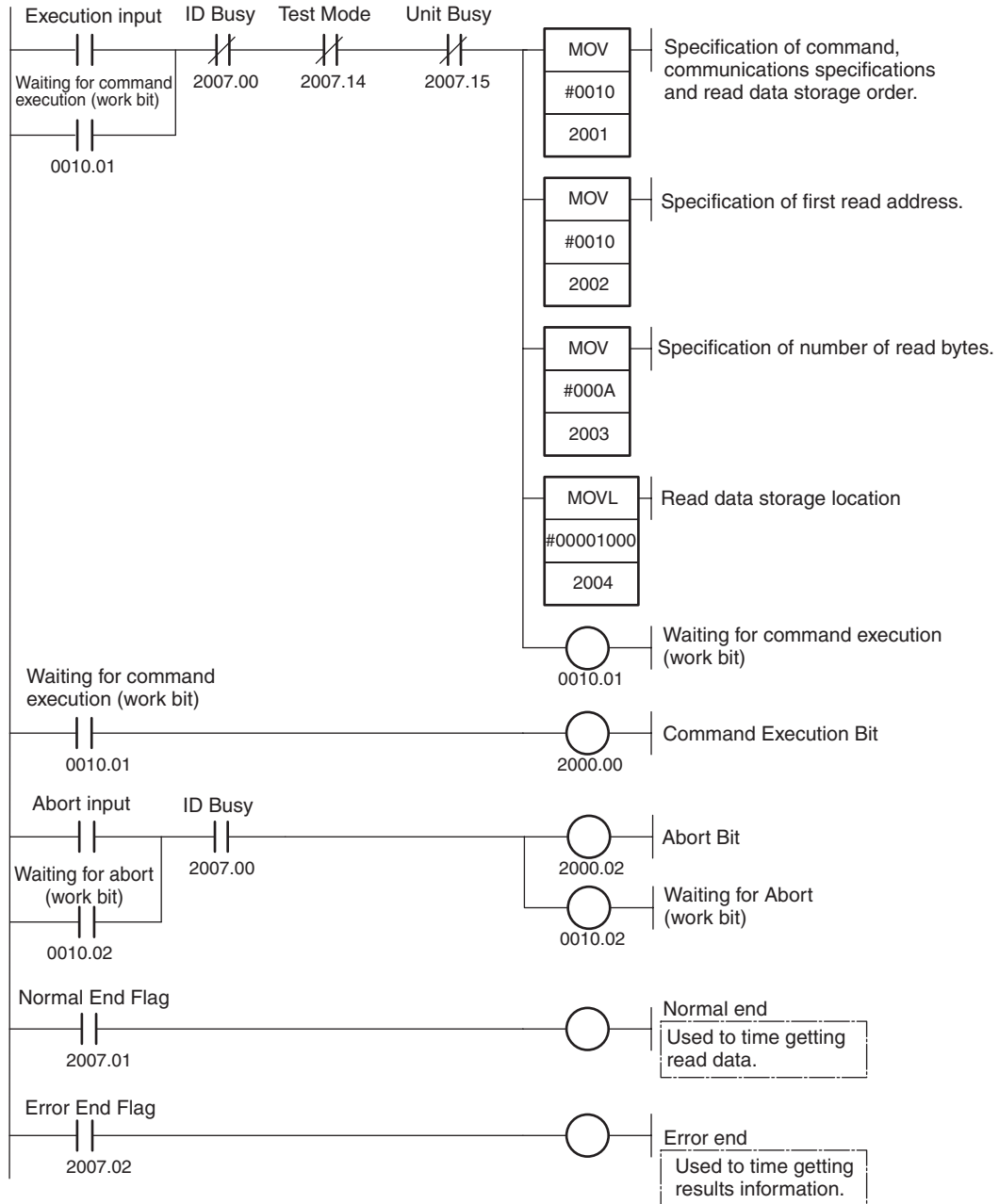

• Timing Chart (CIO n = CIO 2000 + (10 x 0) = CIO 2000)

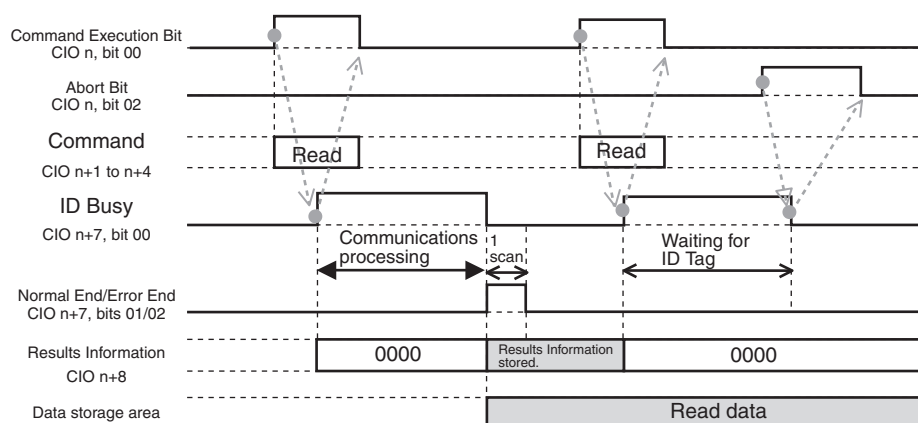

- If communications with the ID Tag fail or an error occurs, communications will be aborted at that point, the error flags in the Results Information (CIO n+8) will turn ON accordingly, and the error code will be placed in the Processing Results Monitor (CIO n+9). The previous read data will not be changed.
- If the Abort Bit is turned ON while waiting for an ID Tag, communications will be aborted at that point. The Results Information (CIO n+8) will always be 0000 hex in this case.
- To confirm the execution results from the user program, use the ON status of the Normal End Flag or Error End Flag in the Unit Status.
- Do not turn ON the Command Execution Bit during command execution (i.e., while the ID Busy Flag is ON). It will be ignored.

Read, Communications Specification: Repeat Auto

• Outline

This example shows how to repeatedly read the data in the memory of ID Tags from Antenna 2. An auto wait time is set so that operation will be ended if an ID Tag is not detected within a specified period of time.

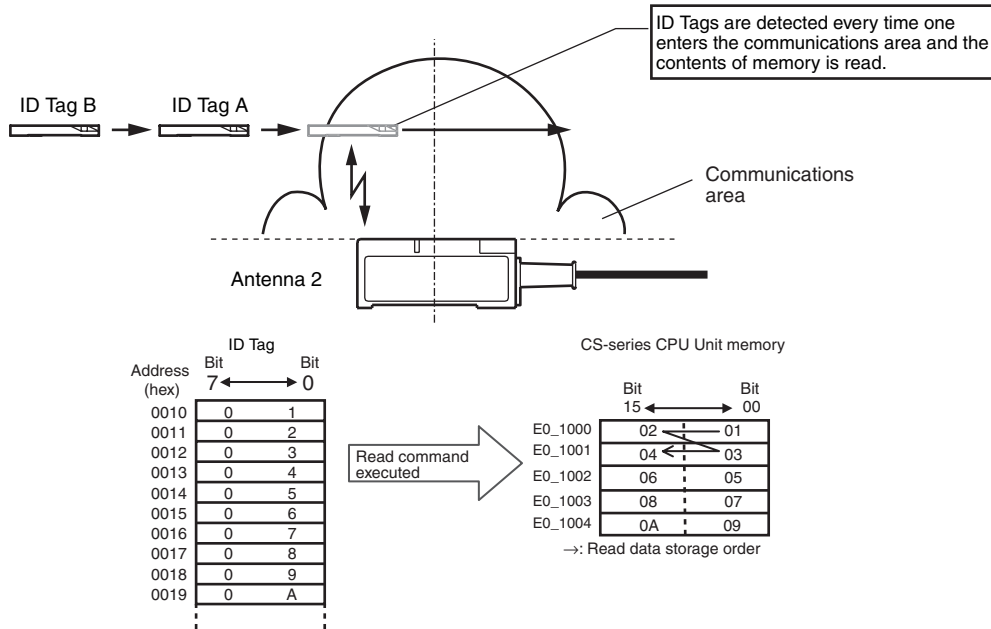

• Unit Settings Example

Item	Setting	Setting location
Unit number	01	Unit's front panel unit number switches: 01
Operating mode	Run Mode	Unit's front panel test switch: OFF
System Settings	UID Addition Setting: Disabled Test Mode Disable Setting: Enabled Setting for Write Verification: Verification Tag Communications Speed Setting: Normal Mode	Set in the Special I/O Unit words in DM Area.
Auto Wait Time Setting	15 s	
Command	Read	Set in the Special I/O Unit Area.
Communications specification	Repeat auto	
Read data storage order	Rightmost → Leftmost	
Read Start address	0010 hex	
Number of bytes to read	10 bytes	
Read data storage destination	E0_1000 to E0_1004	

First word allocated to Unit in DM Area: $m = D20000 + (100 \times (0 + 1)) = D20100$

DM address	Contents				Meaning															
					15	14	13	12	11	10	9	8	7	6	5	4	3	2	1	0
D20100	0	0	0	0	UID Addition Setting				Test Mode Disable Setting				Setting for Write Verification				Tag Communications Speed Setting			
D20101	0150				Auto Wait Time Setting															

First word allocated to Unit in CIO Area: $n = CIO 2000 + 10 \times (0+ 1) = CIO 2010$

Word address	Contents				Meaning															
					15	14	13	12	11	10	9	8	7	6	5	4	3	2	1	0
CIO 2011	0	0	2	1	Command code								Communications specification				Data order			
CIO 2012	00		10		First read address															
CIO 2013	00		0A		Number of read bytes															
CIO 2014	10		00		Read data storage location (rightmost 4 digits)															
CIO 2015	5	0	00		Data storage area				Bank specification				Read data storage location (leftmost 2 digits)							
CIO 2016	00		00		---															

---: Ignored.

• **Programming Example**

When the execution input turns ON, settings are made in the Special I/O Unit Area using the MOV and MOVL instructions and the command is executed. When communications with the ID Tag have been completed, the Normal End Flag (CIO n+7, bit 01) or Error End Flag (CIO n+7, bit 02) is turned ON. Read data can be used after the Normal End Flag (CIO n+7, bit 01) has been ON. If more than 15 seconds elapse while waiting for the ID Tag, the operation will be ended.

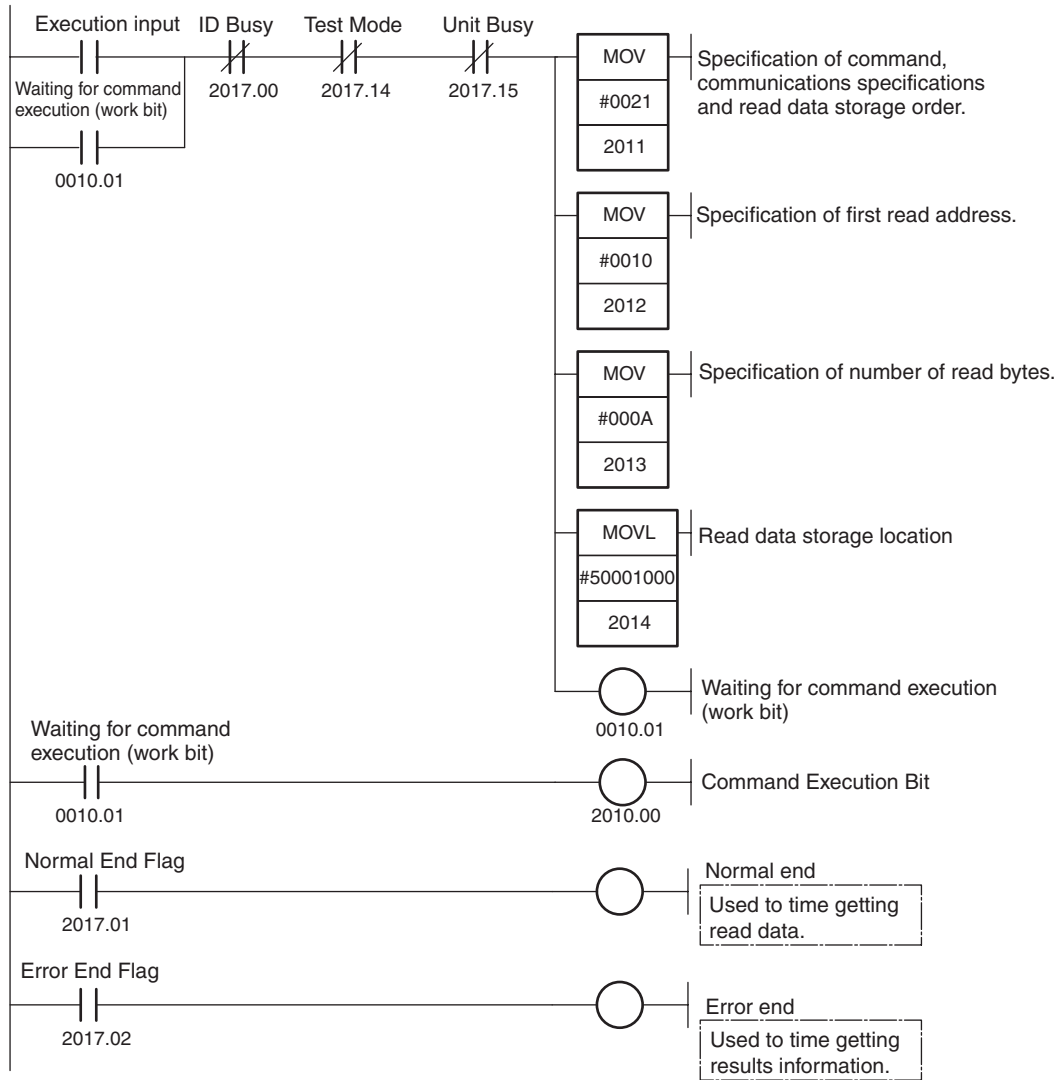

• Timing Chart (CIO n = CIO 2000 + 10 x (0 + 1) = CIO 2010)

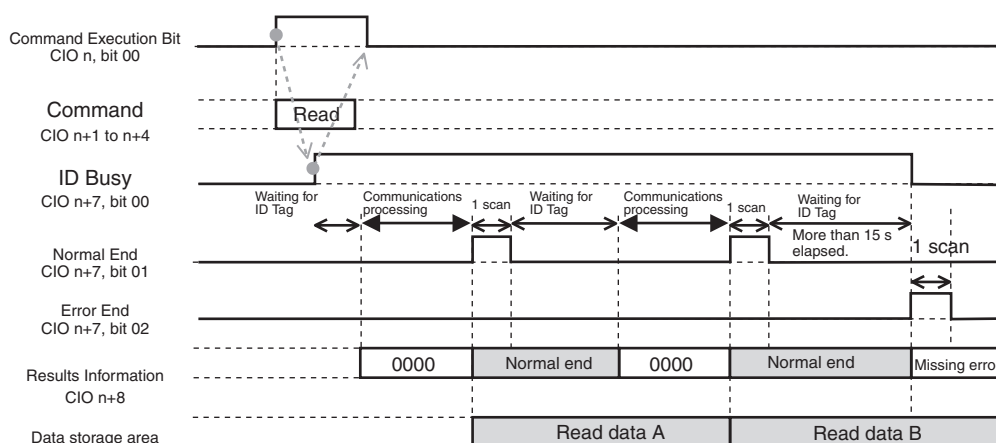

- If communications with the ID Tag fail or an error occurs, communications will be aborted at that point, the error flags in the Results Information (CIO n+8) will turn ON accordingly, and the error code will be placed in the Processing Results Monitor (CIO n+9). The previous read data will not be changed.
- If an auto wait time is set and the set time expires while waiting for an ID Tag, the command operation will be aborted at that point, the ID Tag Missing Error Flag (CIO n+8, bit 10) in the Results Information will turn ON, and an error code will be placed in the Processing Results Monitor (CIO n+9).
- When the communications specification is set to repeat auto, either the Normal End Flag or the Error End Flag will turn ON every scan for consecutive scans. The execution results can be correctly determined by using the ON status of both the Normal End Flag and the Error End Flag in Unit Status.
- To confirm the execution results from the user program, use the ON status of the Normal End Flag or Error End Flag in the Unit Status.
- Do not turn ON the Command Execution Bit during command execution (i.e., while the ID Busy Flag is ON). It will be ignored.

Read, Communications Specification: FIFO Trigger

• Outline

This example shows how to read the memory of an ID Tag that is present in the communications area for Antenna 1.

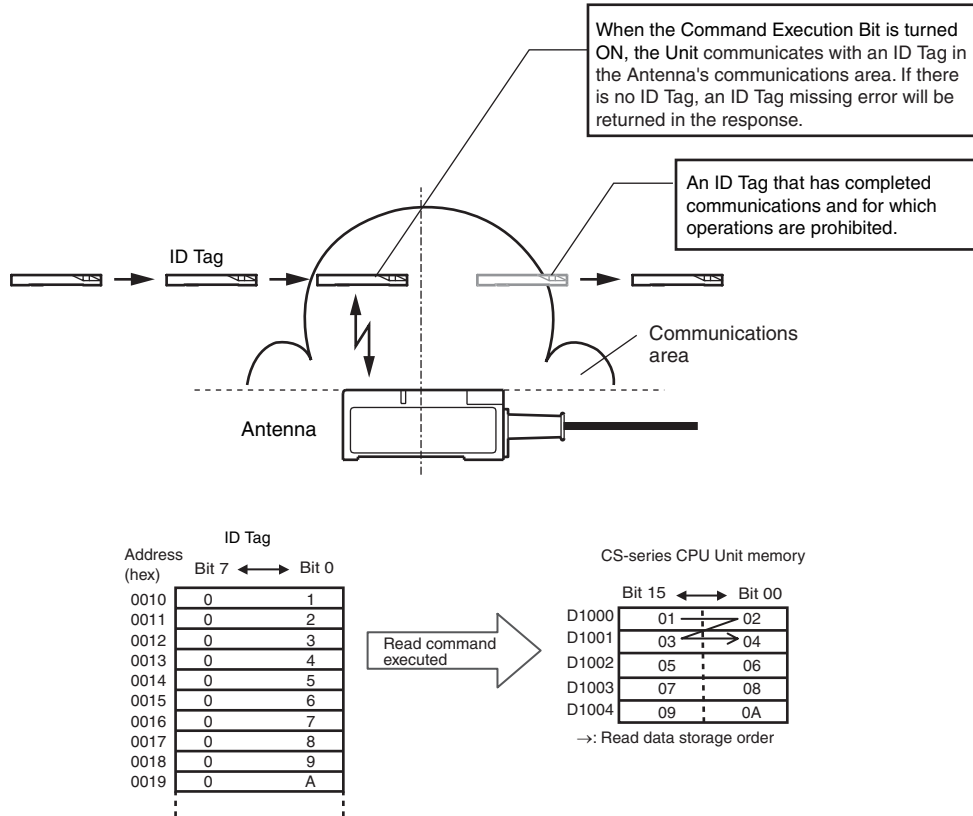

• Unit Settings Example

Item	Setting	Setting location
Unit number	00	Unit's front panel unit number switches: 00
Operating mode	Run Mode	Unit's front panel test switch: OFF
System Settings	UID Addition Setting: Disabled Test Mode Disable Setting: Enabled Setting for Write Verification: Verification Tag Communications Speed Setting: Normal Mode	Set in the Special I/O Unit words in DM Area.
Auto Wait Time Setting	Infinite	
Command	Read	Set in the Special I/O Unit Area.
Communications specification	FIFO trigger	
Read data storage order	Leftmost → Rightmost	
Read Start address	0010 hex	
Number of bytes to read	10 bytes	
Read data storage destination	D1000 to D1004	

First word allocated to Unit in DM Area: $m = D20000 + (100 \times 0) = D20000$

DM address	Contents				Meaning															
					15	14	13	12	11	10	9	8	7	6	5	4	3	2	1	0
D20000	0	0	0	0	UID Addition Setting				Test Mode Disable Setting				Setting for Write Verification				Tag Communications Speed Setting			
D20001	0000				Auto Wait Time Setting															

First word allocated to Unit in CIO Area: $n = CIO\ 2000 + (10 \times 0) = CIO\ 2000$

Word address	Contents				Meaning													
					15	14	13	12	11	10	9	8	7	6	5	4	3	2
CIO 2001	0	0	3	1	Command code						Communications specification				Data order			
CIO 2002	00		10		First read address													
CIO 2003	00		0A		Number of read bytes													
CIO 2004	10		00		Read data storage location (rightmost 4 digits)													
CIO 2005	0	0	00		Data storage area				Bank specification (Always 0)				Read data storage location (leftmost 2 digits)					
CIO 2006	00		00		---													

---: Ignored.

• **Programming Example**

When the execution input turns ON, settings are made in the Special I/O Unit Area using the MOV and MOVL instructions and the command is executed. When communications with the ID Tag have been completed, the Normal End Flag (CIO n+7, bit 01) or Error End Flag (CIO n+7, bit 02) is turned ON. Read data can be used after the Normal End Flag (CIO n+7, bit 01) has been ON. To end command execution while waiting for the ID Tag, turn ON the Abort input.

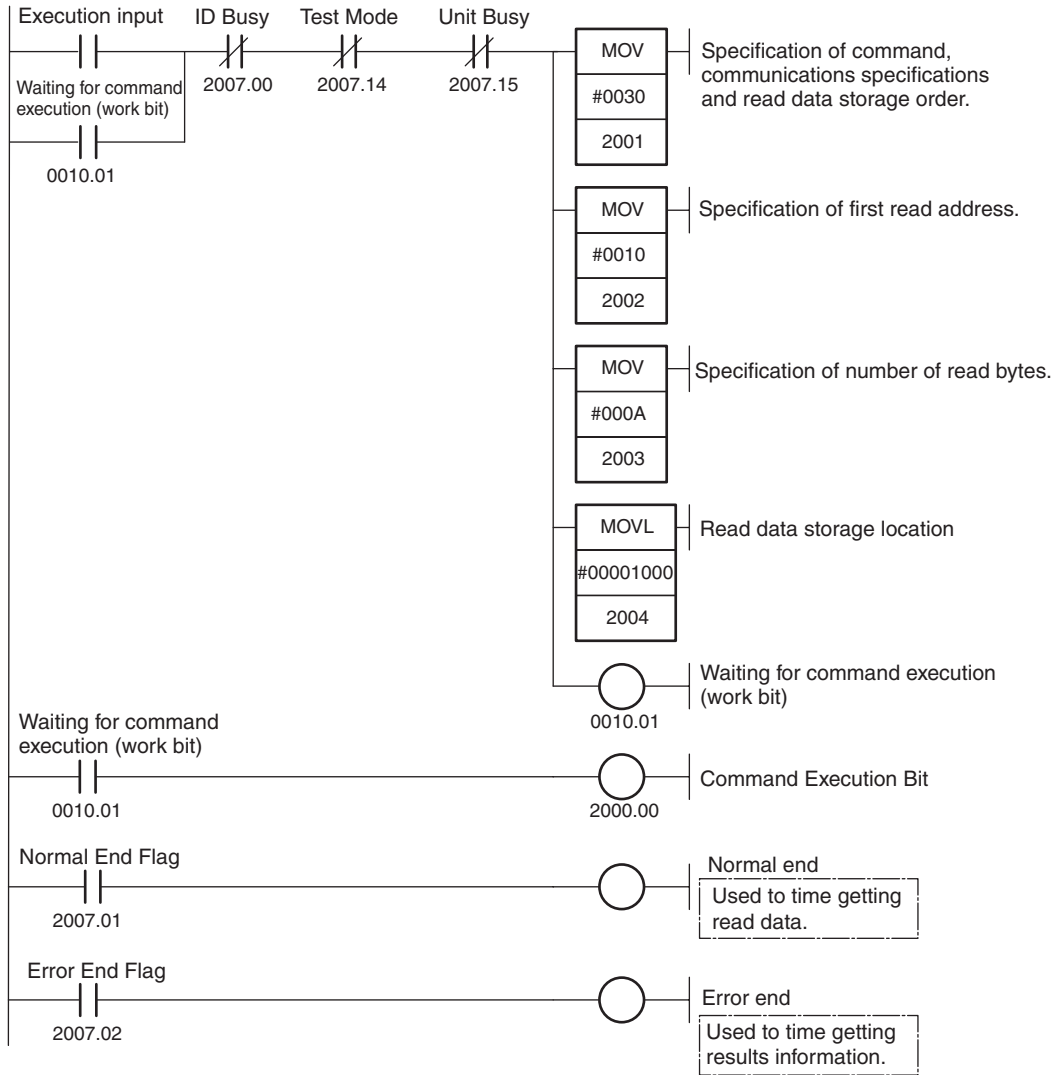

• Timing Chart (CIO n = CIO 2000 + (10 x 0) = CIO 2000)

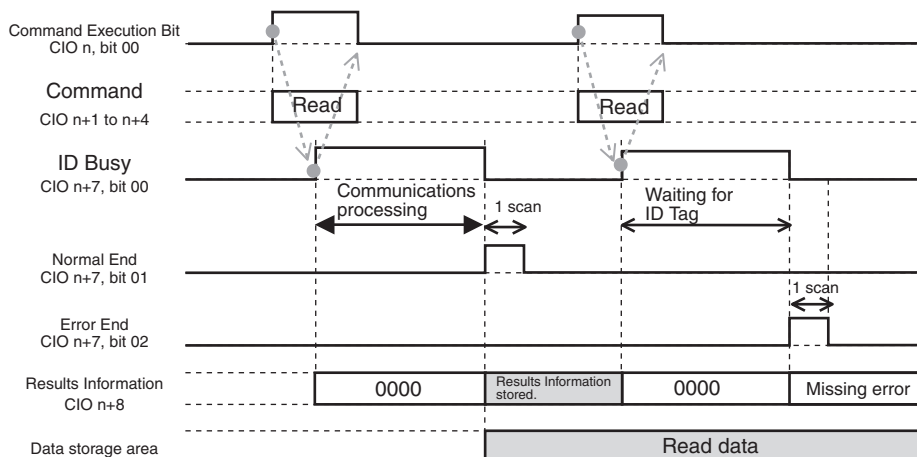

- If communications with the ID Tag fail or an error occurs, communications will be aborted at that point, the error flags in the Results Information (CIO n+8) will turn ON accordingly, and the error code will be placed in the Processing Results Monitor (CIO n+9). The previous read data will not be changed.
- To confirm the execution results from the user program, use the ON status of the Normal End Flag or Error End Flag in the Unit Status.
- Do not turn ON the Command Execution Bit during command execution (i.e., while the ID Busy Flag is ON). It will be ignored.

Read, Communications Specification: FIFO Repeat

• Outline

This example shows how to repeatedly read the memory of ID Tags as they enter the communications area for Antenna 1.

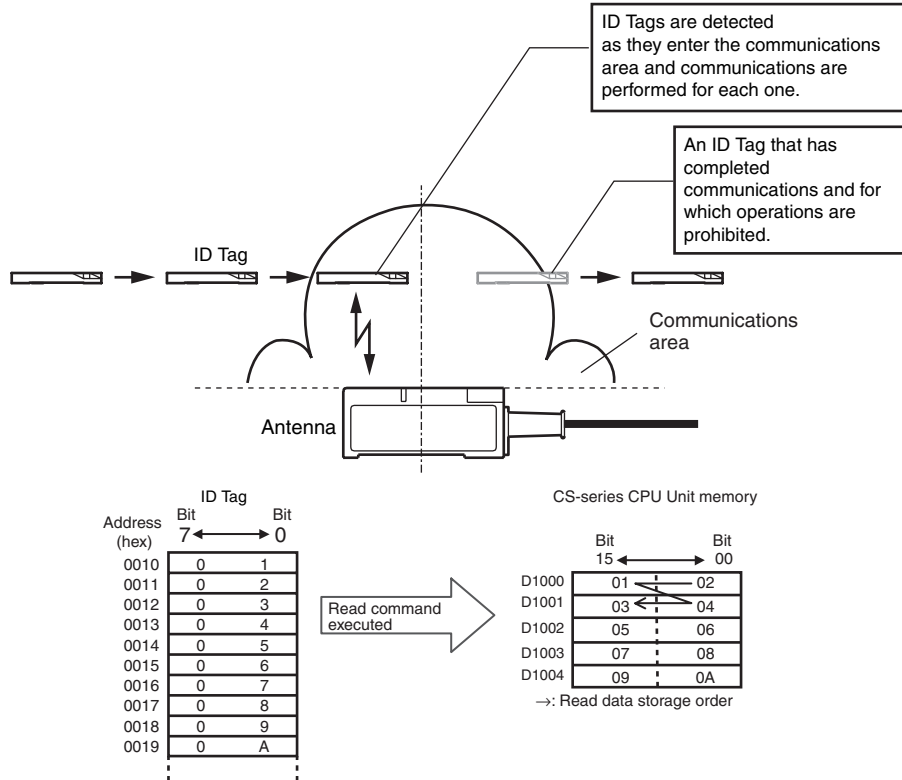

• Unit Settings Example

Item	Setting	Setting location
Unit number	00	Unit's front panel unit number switches: 00
Operating mode	Run Mode	Unit's front panel test switch: OFF
System Settings	UID Addition Setting: Disabled Test Mode Disable Setting: Enabled Setting for Write Verification: Verification Tag Communications Speed Setting: Normal Mode	Set in the Special I/O Unit words in DM Area.
Auto Wait Time Setting	15 s	
Command	Read	Set in the Special I/O Unit Area.
Communications specification	FIFO repeat	
Read data storage order	Leftmost → Rightmost	
Read Start address	0010 hex	
Number of bytes to read	10 bytes	
Read data storage destination	D1000 to D1004	

First word allocated to Unit in DM Area: $m = D20000 + (100 \times 0) = D20000$

DM address	Contents				Meaning															
					15	14	13	12	11	10	9	8	7	6	5	4	3	2	1	0
D20000	0	0	0	0	UID Addition Setting				Test Mode Disable Setting				Setting for Write Verification				Tag Communications Speed Setting			
D20001	0150				Auto Wait Time Setting															

First word allocated to Unit in CIO Area: $n = CIO\ 2000 + (10 \times 0) = CIO\ 2000$

Word address	Contents				Meaning													
					15	14	13	12	11	10	9	8	7	6	5	4	3	2
CIO 2001	0	0	4	0	Command code						Communications specification				Data order			
CIO 2002	00		10		First read address													
CIO 2003	00		0A		Number of read bytes													
CIO 2004	10		00		Read data storage location (rightmost 4 digits)													
CIO 2005	0	0	00		Data storage area				Bank specification (Always 0)				Read data storage location (leftmost 2 digits)					
CIO 2006	00		00		---													

---: Ignored.

• **Programming Example**

When the execution input turns ON, settings are made in the Special I/O Unit Area using the MOV and MOVL instructions and the command is executed. When communications with the ID Tag have been completed, the Normal End Flag (CIO n+7, bit 01) or Error End Flag (CIO n+7, bit 02) is turned ON. Read data can be used after the Normal End Flag (CIO n+7, bit 01) has been ON. To end command execution while waiting for the ID Tag, turn ON the Abort Input.

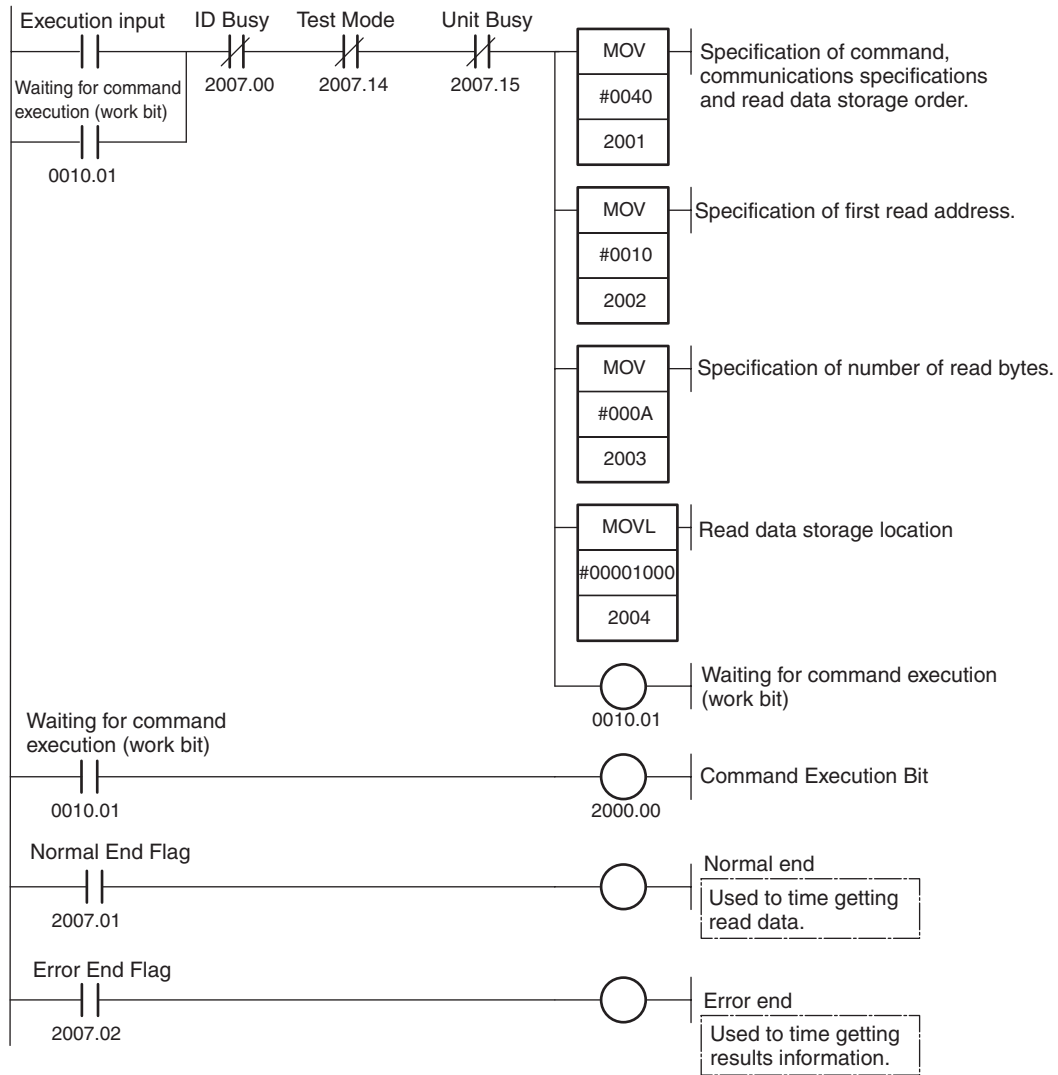

• Timing Chart (CIO n = CIO 2000 + (10 x 0) = CIO 2000)

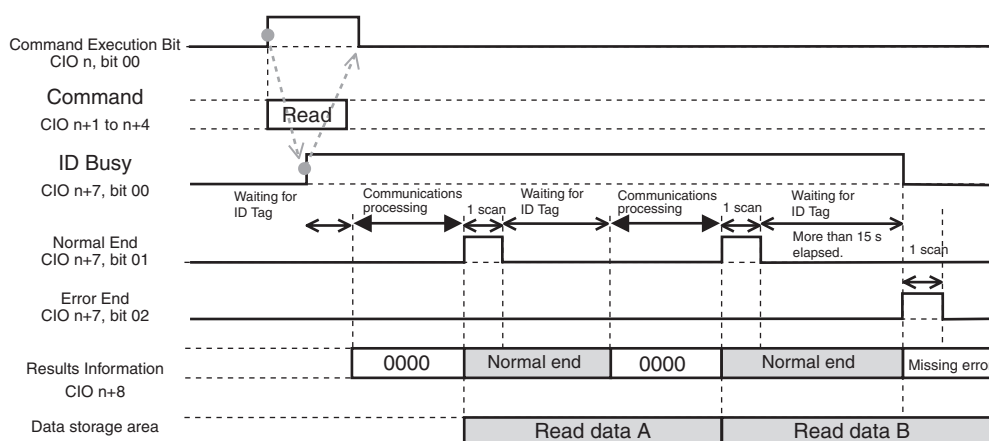

- If communications with the ID Tag fail or an error occurs, communications will be aborted at that point, the error flags in the Results Information (CIO n+8) will turn ON accordingly, and the error code will be placed in the Processing Results Monitor (CIO n+9). The previous read data will not be changed.
- If an auto wait time is set and the set time expires while waiting for an ID Tag, the command operation will be aborted at that point, the ID Tag Missing Error Flag (CIO n+8, bit 10) in the Results Information will turn ON, and an error code will be placed in the Processing Results Monitor (CIO n+9).
- When the communications specification is set to repeat auto, either the Normal End Flag or the Error End Flag will turn ON every scan for consecutive scans. The execution results can be correctly determined by using the ON status of both the Normal End Flag and the Error End Flag in Unit Status.
- To confirm the execution results from the user program, use the ON status of the Normal End Flag or Error End Flag in the Unit Status.
- Do not turn ON the Command Execution Bit during command execution (i.e., while the ID Busy Flag is ON). It will be ignored.

Read, Communications Specification: Multi-access Trigger

• Outline

This example shows how to read the memory of all ID Tags present in the communications area for Antenna 1.

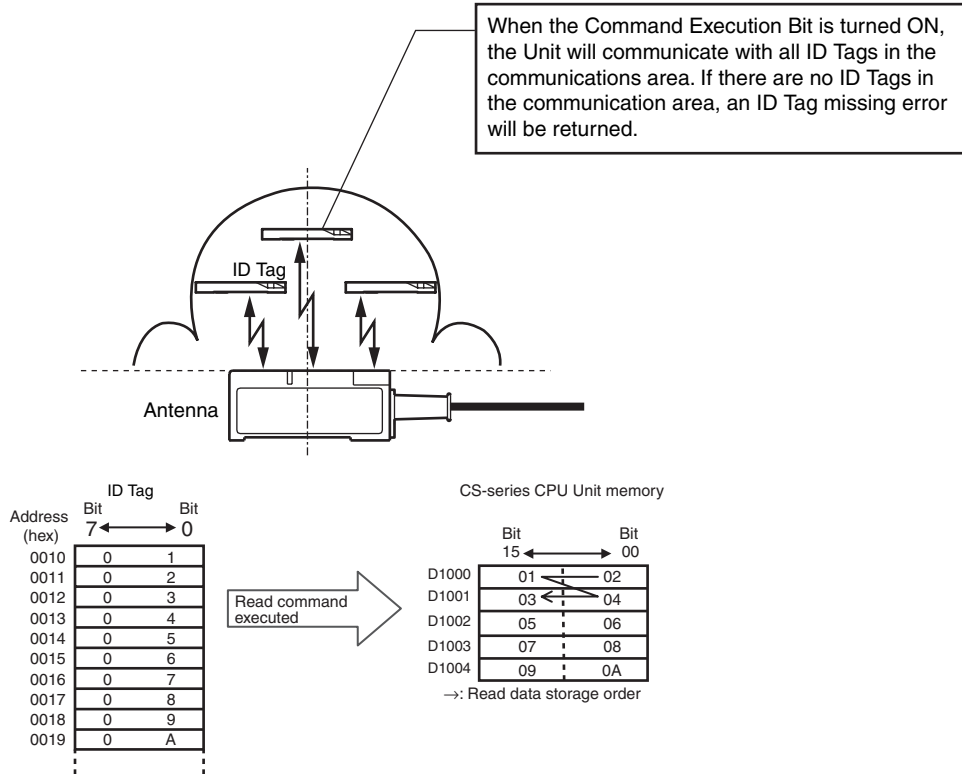

• Unit Setting Example

Item	Setting	Setting location
Unit number	00	Unit's front panel unit number switches: 00
Operating mode	Run Mode	Unit's front panel test switch: OFF
System Settings	UID Addition Setting: Disabled Test Mode Disable Setting: Enabled Setting for Write Verification: Verification Tag Communications Speed Setting: Normal Mode	Set in the Special I/O Unit words in DM Area.
Auto Wait Time Setting	Infinite	
Command	Read	Set in the Special I/O Unit Area.
Communications specification	Multi-access trigger	
Read data storage order	Leftmost → Rightmost	
Read Start address	0010 hex	
Number of bytes to read	10 bytes	
Read data storage destination	D1000 to D1004	



When communications with the ID Tags have been completed, the ID Sensor Unit sends the response sequentially. Move the result data stored in the data storage area to another area before the data from the next ID Tag is stored.

First word allocated to Unit in DM Area: $m = D20000 + (100 \times 0) = D20000$

DM address	Contents				Meaning															
					15	14	13	12	11	10	9	8	7	6	5	4	3	2	1	0
D20000	0	0	0	0	UID Addition Setting				Test Mode Disable Setting				Setting for Write Verification				Tag Communications Speed Setting			
D20001	0000				Auto Wait Time Setting															

First word allocated to Unit in CIO Area: $n = CIO\ 2000 + (10 \times 0) = CIO\ 2000$

Word address	Contents				Meaning													
					15	14	13	12	11	10	9	8	7	6	5	4	3	2
CIO 2001	0	0	5	0	Command code						Communications specification				Data order			
CIO 2002	00		10		First write address													
CIO 2003	00		0A		Number of write bytes													
CIO 2004	10		00		Read data storage location (rightmost 4 digits)													
CIO 2005	0	0	00		Data storage area				Bank specification (Always 0)				Read data storage location (leftmost 2 digits)					
CIO 2006	00		00		---													

---: Ignored.

• **Programming Example**

When the execution input turns ON, settings are made in the Special I/O Unit Area using the MOV and MOVL instructions and the command is executed. When communications with the ID Tag have been completed, the Normal End Flag (CIO n+7, bit 01) or Error End Flag (CIO n+7, bit 02) is turned ON. Read data can be used after the Normal End Flag (CIO n+7, bit 01) has been ON. To end command execution while waiting for the ID Tag, turn ON the Abort Input.

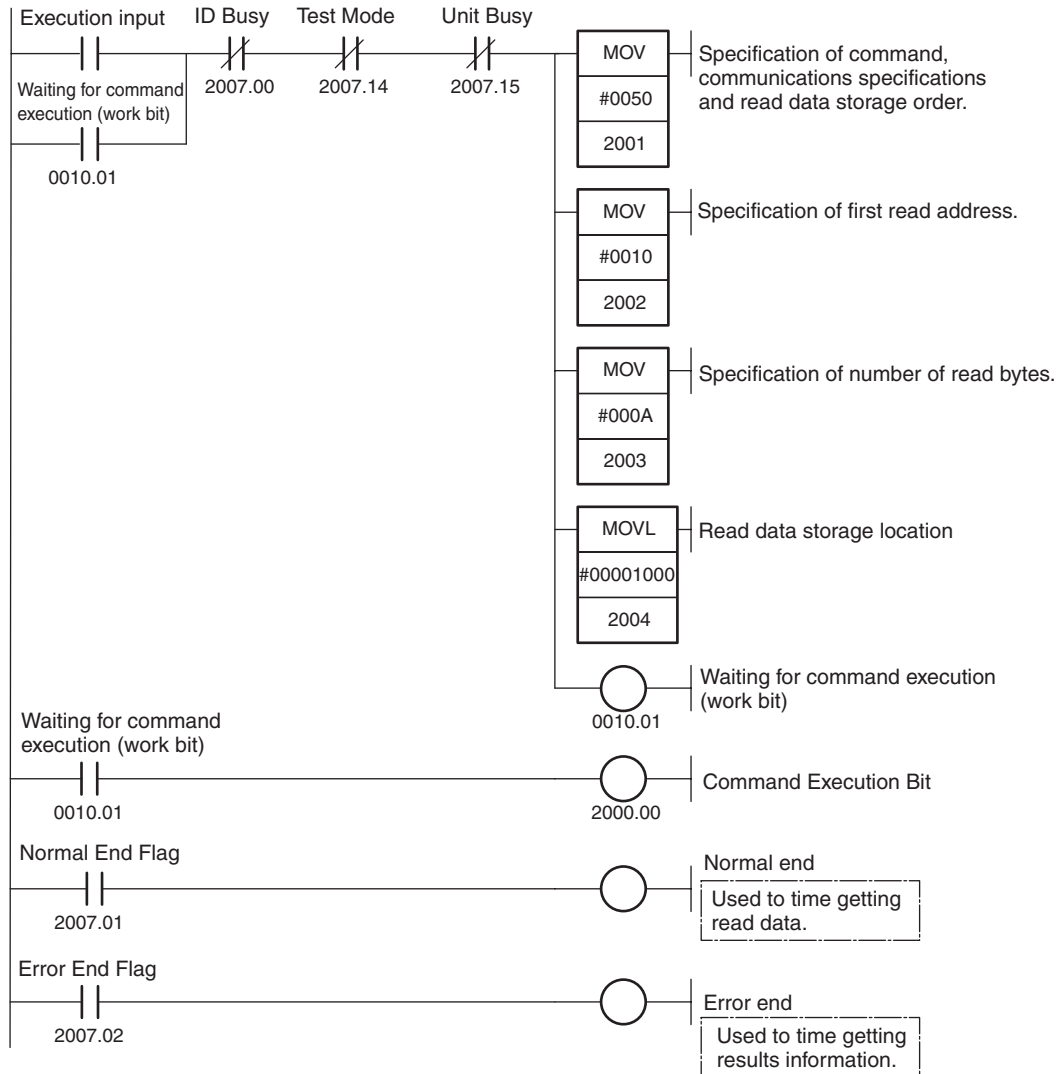

• Timing Chart (CIO n = CIO 2000 + (10 x 0) = CIO 2000)

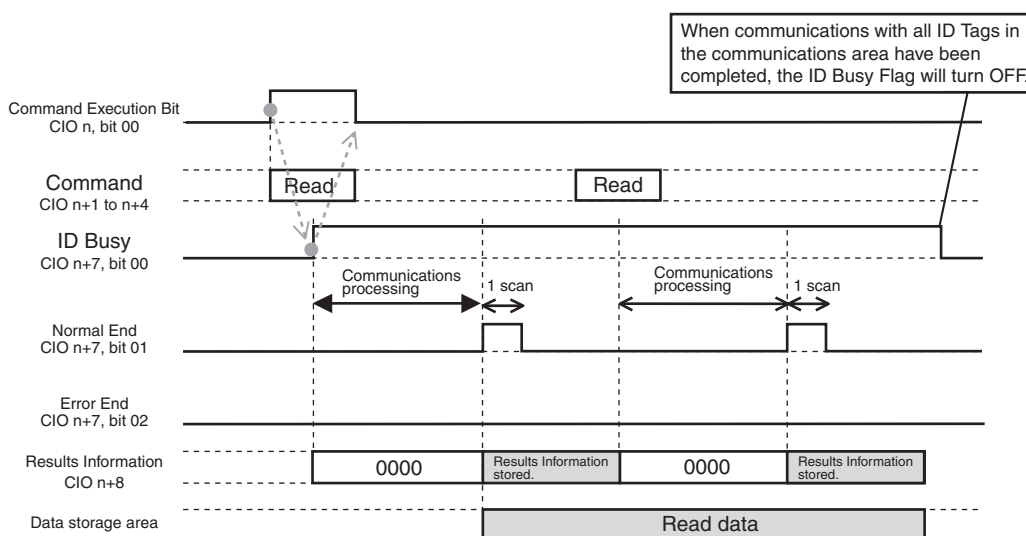

- If communications with the ID Tag fail or an error occurs, communications will be aborted at that point, the error flags in the Results Information (CIO n+8) will turn ON accordingly, and the error code will be placed in the Processing Results Monitor (CIO n+9). The previous read data will not be changed.
- To confirm the execution results from the user program, use the ON status of the Normal End Flag or Error End Flag in the Unit Status.
- Do not turn ON the Command Execution Bit during command execution (i.e., while the ID Busy Flag is ON). It will be ignored.

Read, Communications Specification: Multi-access Repeat

• Outline

This example shows how to repeatedly read the memory of ID Tags as they enter the communications area for Antenna 1.

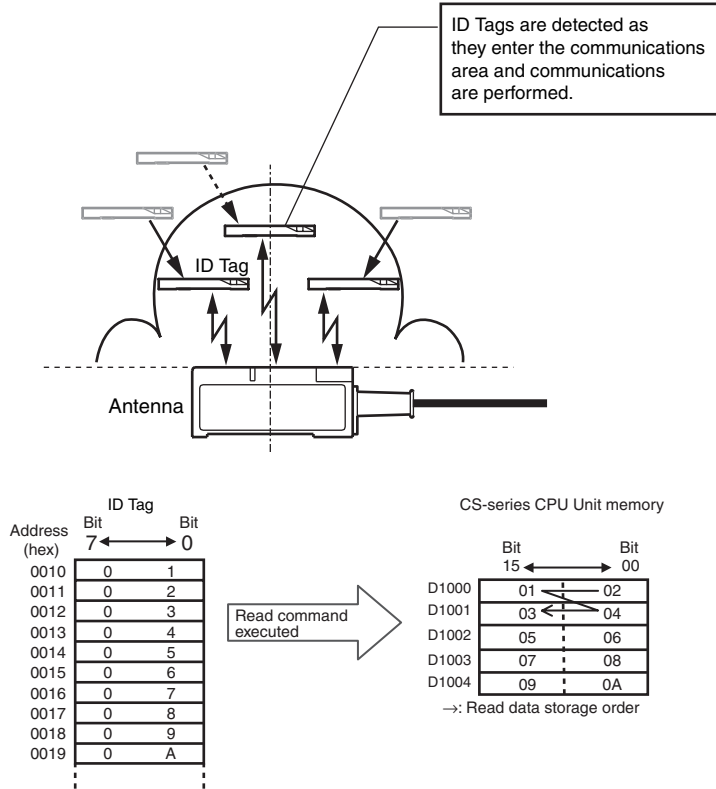

• Unit Settings Example

Item	Setting	Setting location
Unit number	00	Unit's front panel unit number switches: 00
Operating mode	Run Mode	Unit's front panel test switch: OFF
System Settings	UID Addition Setting: Disabled Test Mode Disable Setting: Enabled Setting for Write Verification: Verification Tag Communications Speed Setting: Normal Mode	Set in the Special I/O Unit words in DM Area.
Auto Wait Time Setting	15 s	
Command	Read	Set in the Special I/O Unit Area.
Communications specification	Multi-access repeat	
Read data storage order	Leftmost → Rightmost	
Read Start address	0010 hex	
Number of bytes to read	10 bytes	
Read data storage destination	D1000 to D1004	

First word allocated to Unit in DM Area: $m = D20000 + (100 \times 0) = D20000$

DM address	Contents				Meaning															
					15	14	13	12	11	10	9	8	7	6	5	4	3	2	1	0
D20000	0	0	0	0	UID Addition Setting				Test Mode Disable Setting				Setting for Write Verification				Tag Communications Speed Setting			
D20001	0150				Auto Wait Time Setting															

First word allocated to Unit in CIO Area: $n = CIO\ 2000 + (10 \times 0) = CIO\ 2000$

Word address	Contents				Meaning															
					15	14	13	12	11	10	9	8	7	6	5	4	3	2	1	0
CIO 2001	0	0	6	0	Command code								Communications specification				Data order			
CIO 2002	00		10		First write address															
CIO 2003	00		0A		Number of write bytes															
CIO 2004	10		00		Read data storage location (rightmost 4 digits)															
CIO 2005	0	0	00		Data storage area				Bank specification (Always 0)				Read data storage location (leftmost 2 digits)							
CIO 2006	00		00		---															

---: Ignored.

• **Programming Example**

When the execution input turns ON, settings are made in the Special I/O Unit Area using the MOV and MOVL instructions and the command is executed. When communications with the ID Tag have been completed, the Normal End Flag (CIO n+7, bit 01) or Error End Flag (CIO n+7, bit 02) is turned ON. Read data can be used after the Normal End Flag (CIO n+7, bit 01) has been ON. To end command execution while waiting for the ID Tag, turn ON the Abort Input.

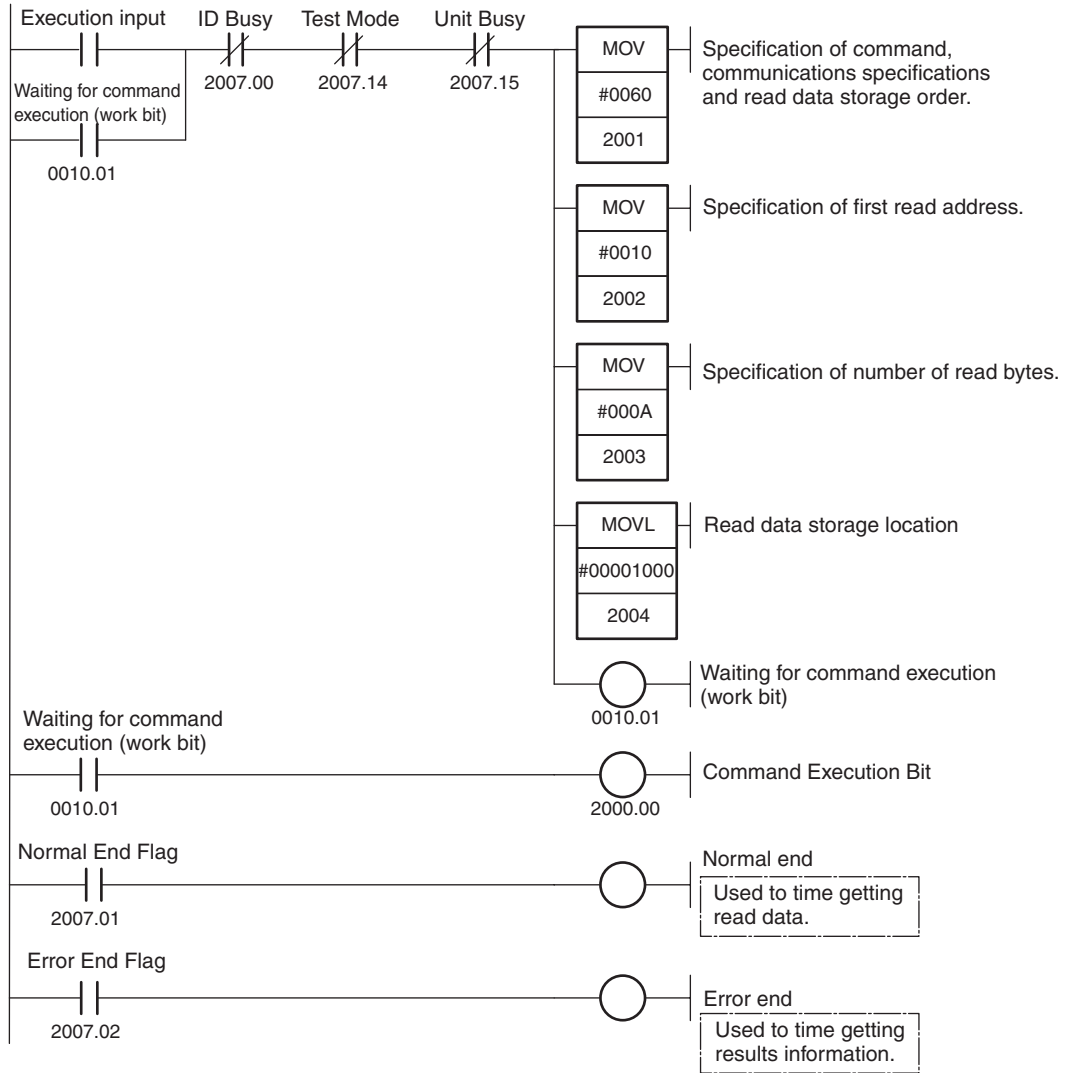

• Timing Chart (CIO n = CIO 2000 + (10 x 0) = CIO 2000)

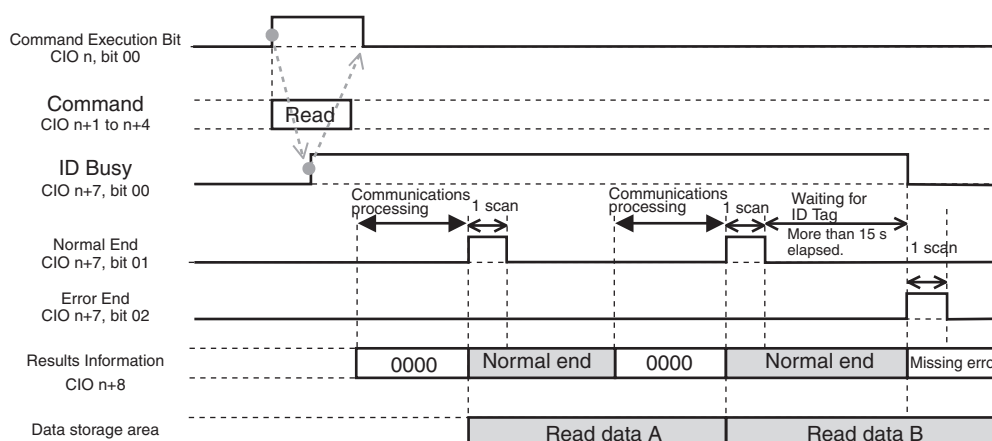

- If communications with the ID Tag fail or an error occurs, communications will be aborted at that point, the error flags in the Results Information (CIO n+8) will turn ON accordingly, and the error code will be placed in the Processing Results Monitor (CIO n+9). The previous read data will not be changed.
- If an auto wait time is set and the set time expires while waiting for an ID Tag, the command operation will be aborted at that point, the ID Tag Missing Error Flag (CIO n+8, bit 10) in the Results Information will turn ON, and an error code will be placed in the Processing Results Monitor (CIO n+9).
- When the communications specification is set to repeat auto, either the Normal End Flag or the Error End Flag will turn ON every scan for consecutive scans. The execution results can be correctly determined by using the ON status of both the Normal End Flag and the Error End Flag in Unit Status.
- To confirm the execution results from the user program, use the ON status of the Normal End Flag or Error End Flag in the Unit Status.
- Do not turn ON the Command Execution Bit during command execution (i.e., while the ID Busy Flag is ON). It will be ignored.

Write, Communications Specification: Trigger

■ Outline

This example shows how to write data to the memory of an ID Tag in the communications area of Antenna 1.

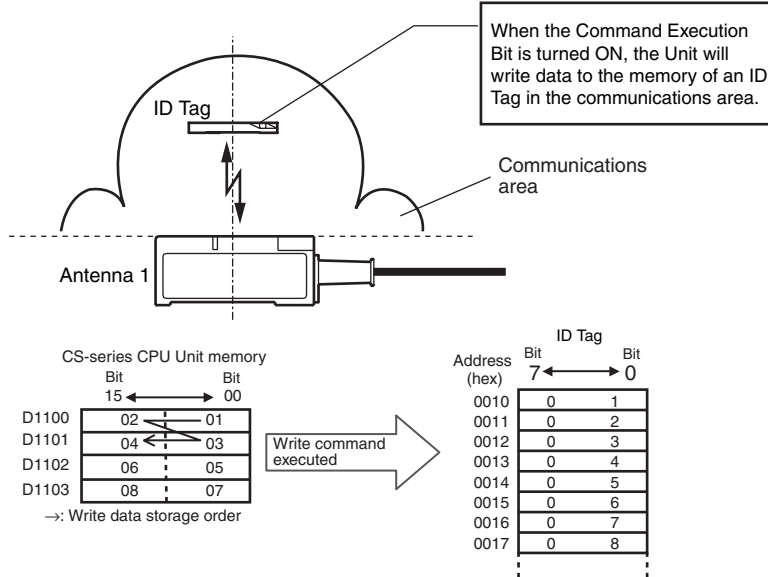

■ Unit Settings Example

Item	Setting	Setting location
Unit number	55	Unit's front panel unit number switches: 55
Operating mode	Run Mode	Unit's front panel test switch: OFF
System Settings	UID Addition Setting: Disabled Test Mode Disable Setting: Enabled Setting for Write Verification: Verification Tag Communications Speed Setting: Normal Mode Data transfer setting: Cyclic	Set in the Special I/O Unit words in DM Area.
Auto Wait Time Setting	Infinite	
Command	Write	Set in the Special I/O Unit Area.
Communications specification	Trigger	
Write data storage order	Rightmost → Leftmost	
Write Start address	0010 hex	
Number of bytes to write	8 bytes	
Write data storage destination	D1000 to D1004	

First word allocated to Unit in DM Area: $m = D20000 + (100 \times 55) = D25500$

DM address	Contents				Meaning															
					15	14	13	12	11	10	9	8	7	6	5	4	3	2	1	0
D25500	0	0	0	0	UID Addition Setting				Test Mode Disable Setting				Setting for Write Verification				Tag Communications Speed Setting			
D25501	0000				Auto Wait Time Setting															

First word allocated to Unit in CIO Area: $n = CIO 2000 + (10 \times 55) = CIO 2550$

Word address	Contents				Meaning												
					15	14	13	12	11	10	9	8	7	6	5	4	3
CIO 2551	01	0	1	Command code						Communications specification				Data order			
CIO 2552	00	10			First write address												
CIO 2553	00	08			Number of write bytes												
CIO 2554	11	00			Read data storage location (rightmost 4 digits)												
CIO 2555	0	0	00	Data storage area				Bank specification (Always 0)				Write data storage location (leftmost 2 digits)					
CIO 2556	00	00			---												

---: Ignored.

• **Programming Example**

When the execution input turns ON, settings are made in the Special I/O Unit Area using the MOV and MOVL instructions and the command is executed. When communications with the ID Tag have been completed, the Normal End Flag (CIO n+7, bit 01) or Error End Flag (CIO n+7, bit 02) is turned ON.

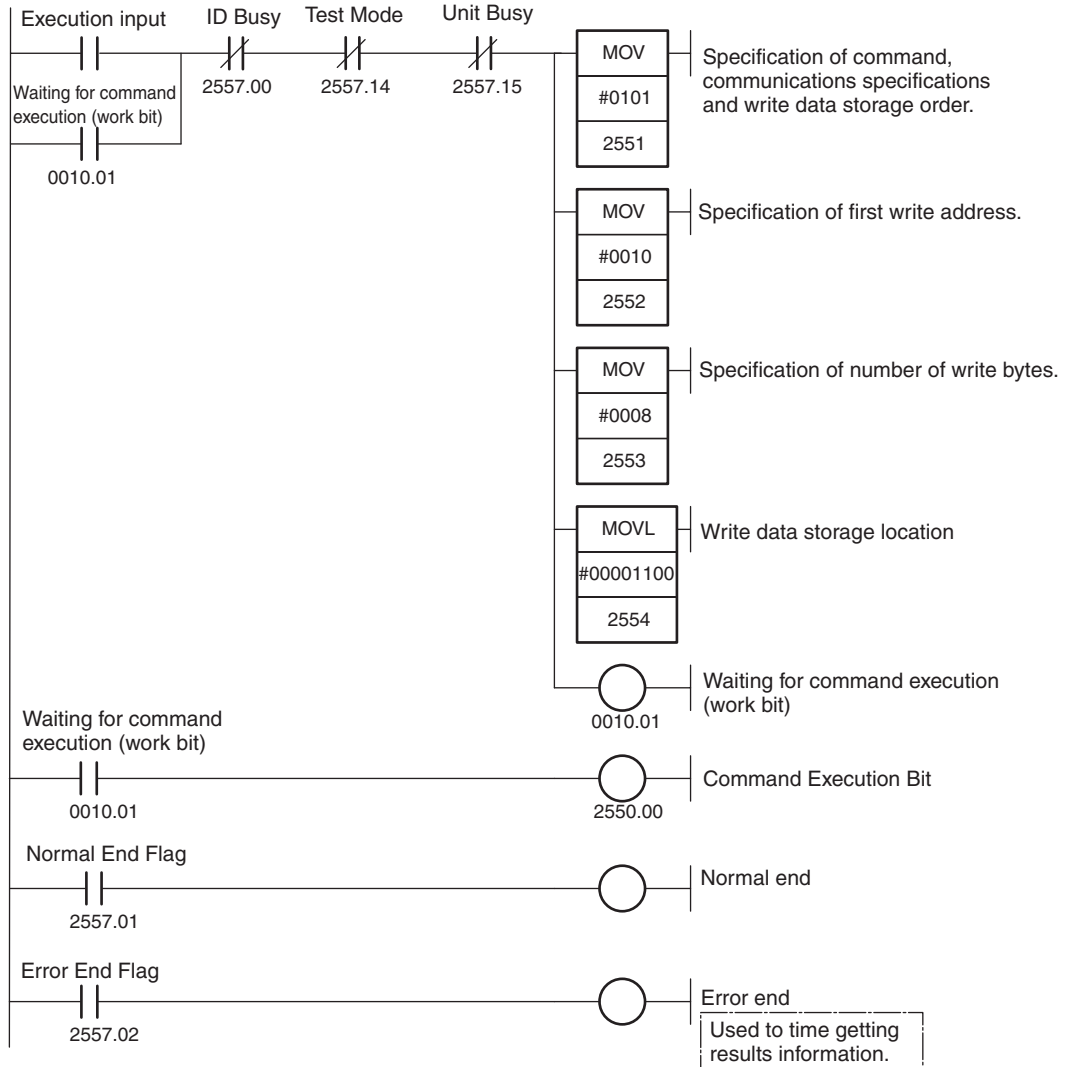

• **Timing Chart (CIO n = CIO 2000 + (10 x 55) = CIO 2550)**

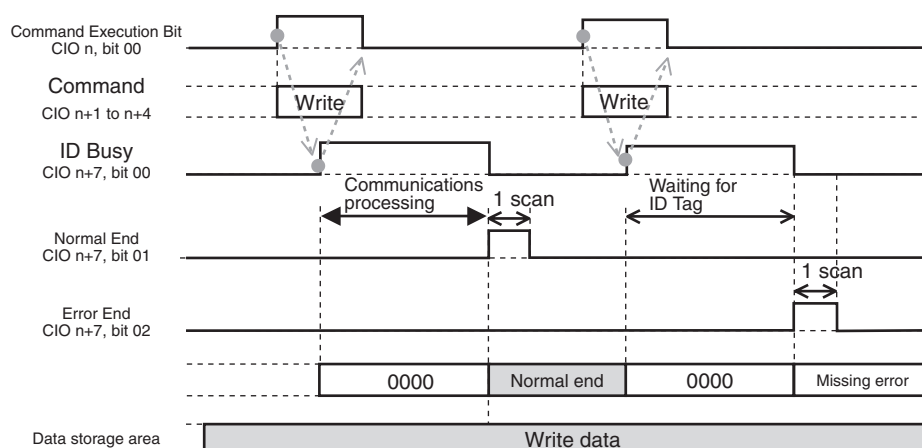

- To confirm the execution results from the user program, use the ON status of the Normal End Flag or Error End Flag in the Unit Status.
- Do not turn ON the Command Execution Bit during command execution (i.e., while the ID Busy Flag is ON). It will be ignored.

Write, Communications Specification: Trigger, Data Transfer: Intelligent I/O Instructions

■ Outline

This example shows how to write data to the memory of an ID Tag that is present in the communications area for Antenna 1.

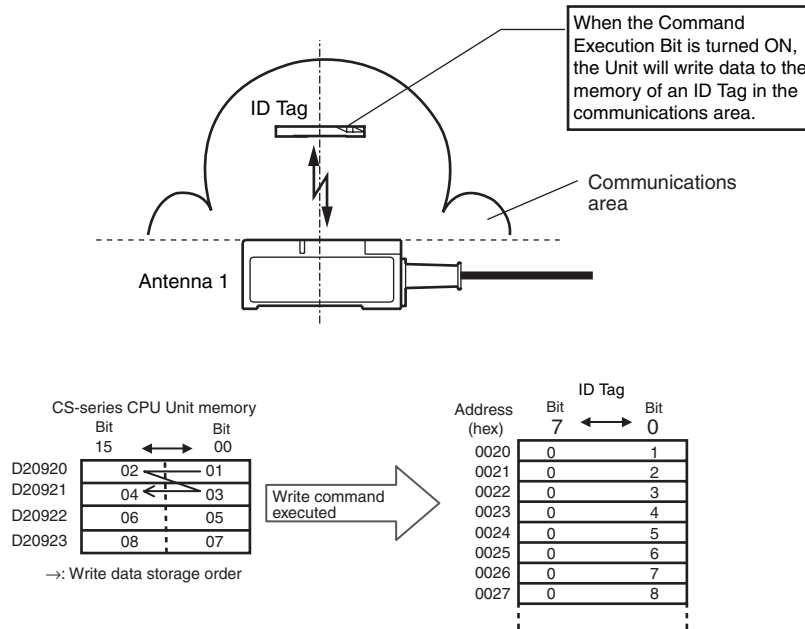

■ Unit Settings Example

Item	Setting	Setting location
Unit number	00	Unit's front panel unit number switches: 00
Operating mode	Run Mode	Unit's front panel test switch: OFF
System Settings	UID Addition Setting: Disabled Test Mode Disable Setting: Enabled Setting for Write Verification: Verification Tag Communications Speed Setting: Normal Mode Data Transfer Setting: Intelligent I/O Instructions	Set in the Special I/O Unit words in DM Area.
Auto Wait Time Setting	Infinite	
Command	Write	Set in the Special I/O Unit Area.
Communications specification	Trigger	
Write data storage order	Rightmost → Leftmost	
Write Start address	0020 hex	
Number of bytes to write	512 bytes	Set in IOWR instruction.
Write data storage destination	D20920 to D21431	

First word allocated to Unit in DM Area: $m = D20000 + (100 \times 0) = D20000$

DM address	Contents				Meaning															
					15	14	13	12	11	10	9	8	7	6	5	4	3	2	1	0
D20000	0	0	0	0	UID Addition Setting				Test Mode Disable Setting				Setting for Write Verification				Tag Communications Speed Setting			
D20001	0000				Auto Wait Time Setting															
D20090	0001				Data Transfer Setting															

First word allocated to Unit in CIO Area: $n = CIO 2000 + (10 \times 0) = CIO 2000$

Word address	Contents				Meaning															
					15	14	13	12	11	10	9	8	7	6	5	4	3	2	1	0
CIO 2001	01	0	1	Command code								Communications specification				Data order				
CIO 2002	00	20			Write start address															
CIO 2003	02	00			Number of bytes to write															
CIO 2004	00	00			---															
CIO 2005	0	0	00		---															
CIO 2006	00	00			---															

---: Ignored.

• **Programming Example**

Execute the IOWR instruction before starting execution of the write command.

When the command execution input turns ON, settings are made in the Special I/O Unit Area using MOV instructions and the command is executed. When communications with the ID Tag have been completed, the Normal End Flag (CIO n+7, bit 01) or Error End Flag (CIO n+7, bit 02) is turned ON. The following ladder programming uses the Write command and the IOWR instruction to write 512 bytes of data.

The IOWR instruction is executed twice to write 256 bytes (128 words) each time.

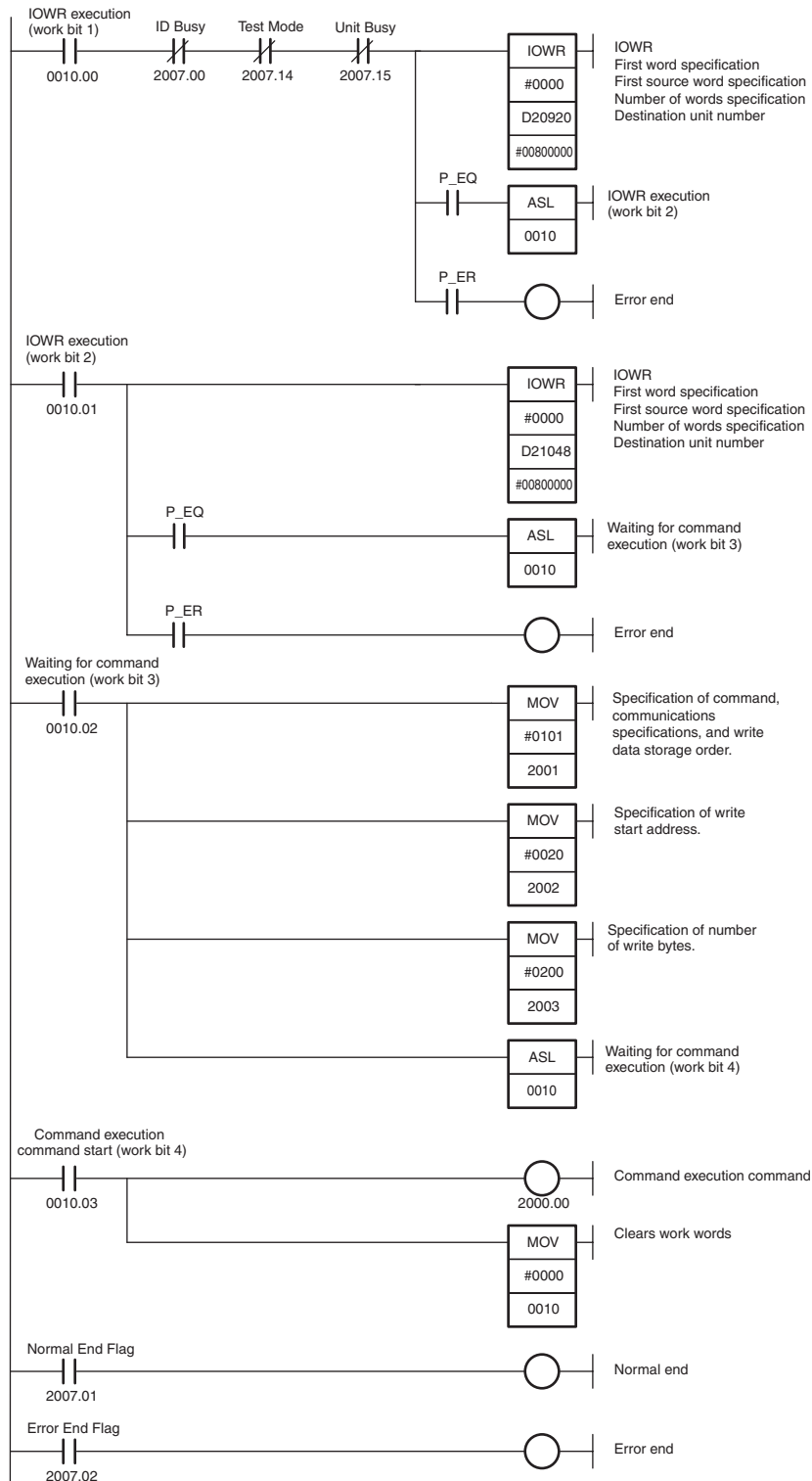

• **Timing Chart (CIO n = CIO 2000 + (10 x 55) = CIO 2550)**

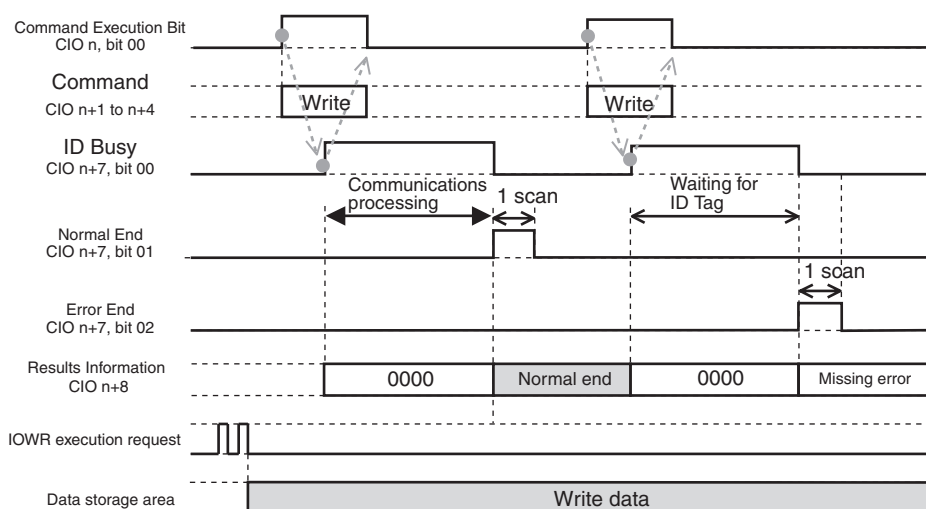

- To confirm the execution results from the user program, use the ON status of the Normal End Flag or Error End Flag. These flags show the Unit status.
- Do not turn ON the Command Execution Bit during command execution (i.e., while the ID Busy Flag is ON). It will be ignored.
- Execute the IOWR instruction before executing the write command.

Copy, Communications Specification: Single Auto

• Outline

This example shows how to read data from the memory of an ID Tag A when it enters the communications area for Antenna 1 and then write the data to ID Tag B in the communications area for Antenna 2.

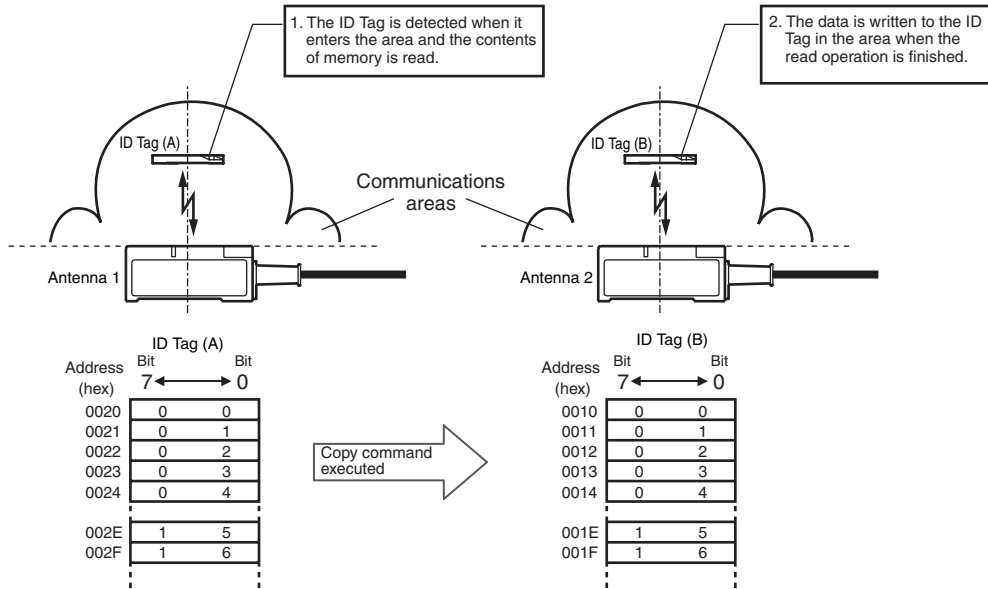

• Unit Setting Example

Item	Setting	Setting location
Unit number	77	Unit's front panel unit number switches: 77
Operating mode	Run Mode	Unit's front panel test switch: OFF
System Settings	UID Addition Setting: Disabled Test Mode Disable Setting: Enabled Setting for Write Verification: Verification Tag Communications Speed Setting: Normal Mode	Set in the Special I/O Unit words in DM Area.
Auto Wait Time Setting	Infinite	
Command	Copy	Set in the Special I/O Unit Area.
Communications specification	Trigger	
Read start address	0020 hex	
Number of read/write bytes	16 bytes	
Write start address	0010 hex	

First word allocated to Unit in DM Area: $m = D20000 + (100 \times 77) = D27700$

DM address	Contents				Meaning															
					15	14	13	12	11	10	9	8	7	6	5	4	3	2	1	0
D27700	0	0	0	0	UID Addition Setting				Test Mode Disable Setting				Setting for Write Verification				Tag Communications Speed Setting			
D27701	0000				Auto Wait Time Setting															

First Word Allocated to Unit in CIO Area: $n = CIO 2000 + (10 \times 77) = CIO 2770$

Word address	Contents				Meaning											
					15	14	13	12	11	10	9	8	7	6	5	4
CIO 2771	09	0	0	0	Command code						Communications specification				---	
CIO 2772	00	20			First processing address											
CIO 2773	00	10			Number of processing bytes											
CIO 2774	00	00			---											
CIO 2775	0	0	00		---				---				---			
CIO 2776	00	10			Command option											

---: Ignored.

• **Programming Example**

When the execution input turns ON, settings are made in the Special I/O Unit Area using the MOV instruction and the command is executed. Data is read from the memory of ID Tag A and written to the memory of ID Tag B. When communications with ID Tag B have been completed, the Normal End Flag (CIO n+7, bit 01) or Error End Flag (CIO n+7, bit 02) is turned ON.

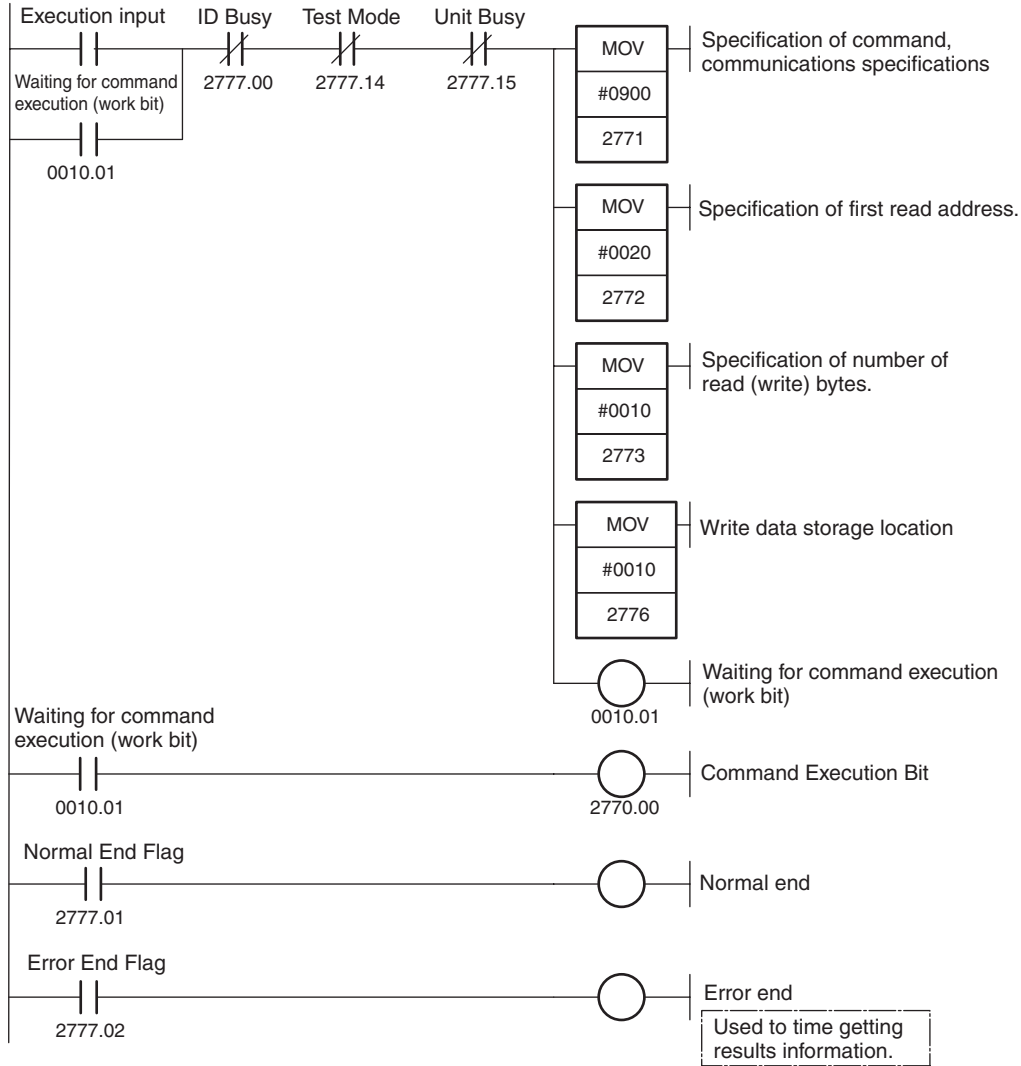

• **Timing Chart (CIO n = CIO 2000 + (10 × 77) = CIO 2770)**

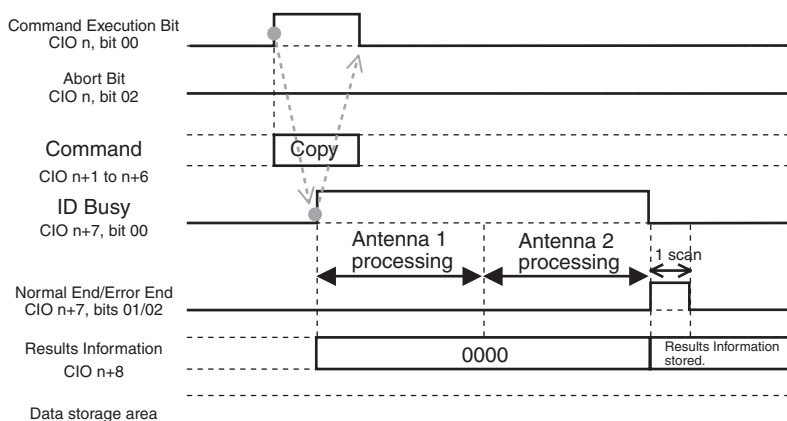

- To confirm the execution results from the user program, use the ON status of the Normal End Flag or Error End Flag in the Unit Status.
- Do not turn ON the Command Execution Bit during command execution (i.e., while the ID Busy Flag is ON). It will be ignored.

Data Coding Tables

Special I/O Unit Words Allocated in DM Area

First word allocated to Antenna 1: $m = D20000 + (100 \times \text{Unit number})$

First word allocated to Antenna 2: $m = D20000 + (100 \times (\text{Unit number} + 1))$

System Settings: DM m (= D2□□00)

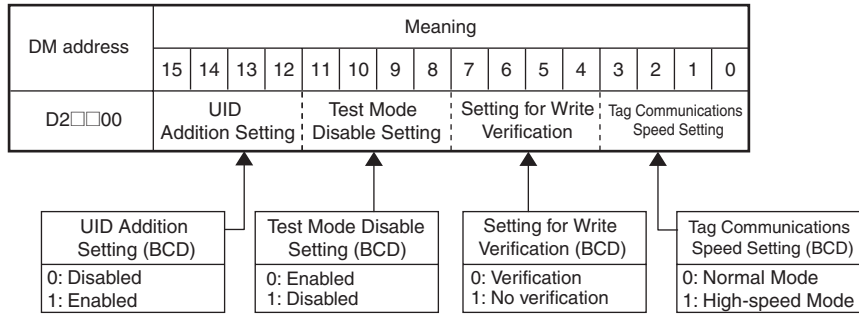

Auto Wait Time Setting: DM m+1 (= D2□□01)

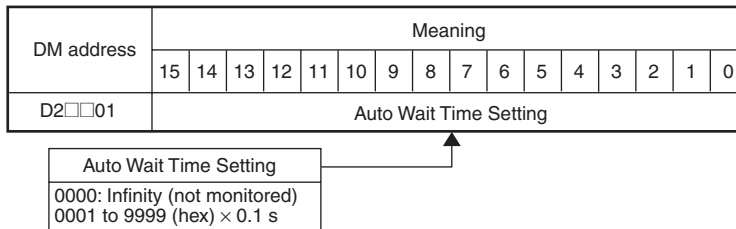

Words Allocated in Special I/O Unit Area in CIO Area

First word allocated to Antenna 1: $n = \text{CIO } 2000 + (10 \times \text{Unit number})$

First word allocated to Antenna 2: $n = \text{CIO } 2000 + (10 \times (\text{Unit number} + 1))$

Unit Controls: CIO n (= CIO 2□□0)

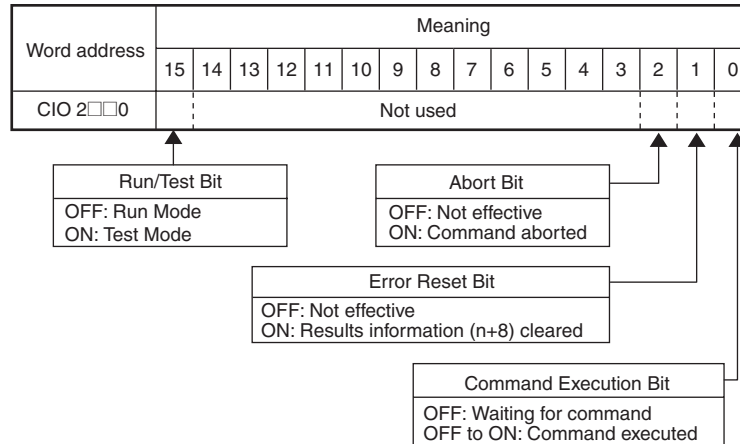

Command: Words (CIO n+1) to (CIO n+3) (= CIO 2□□1 to CIO 2□□3)

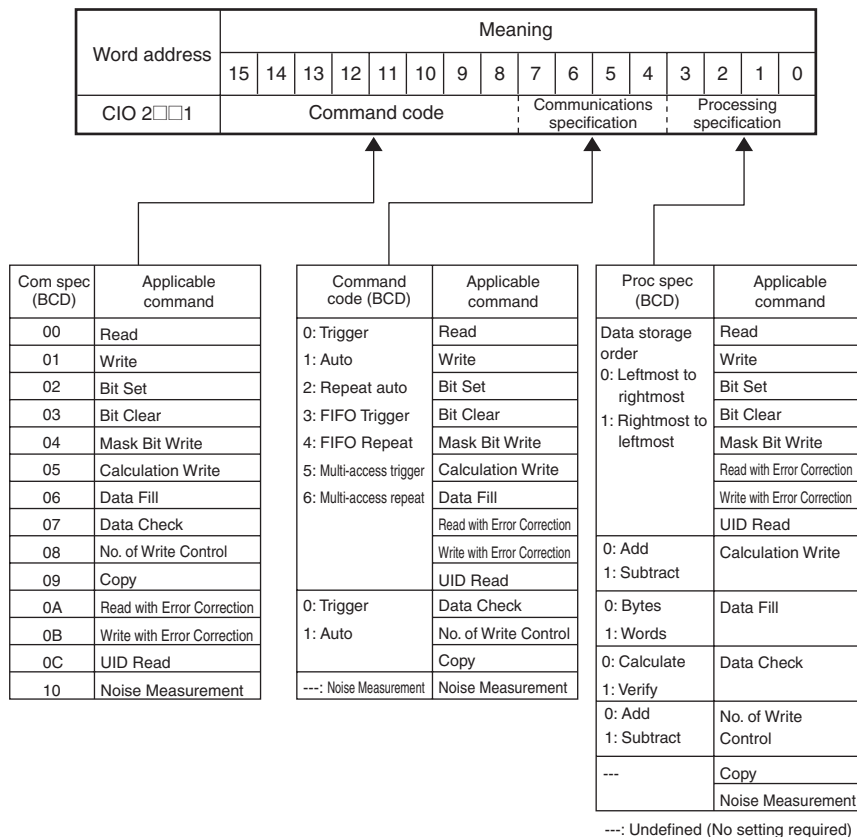

Word address	Meaning															
	15	14	13	12	11	10	9	8	7	6	5	4	3	2	1	0
CIO 2□□2	Processing address															
CIO 2□□3	Number of bytes to process															

No. of bytes (hex)	Applicable command
0001 to 0800	Read Write
0001 to 0004	Bit Set Bit Clear
---	Mask Bit Write
0001 to 0004	Calculation Write
0000 (All)	Data Fill
0001 to 0800	Data Check
0003 to 0800	Data Check
---	No. of Write Control
0001 to 0800	Copy
0001 to 01FE	Read with Error Correction Write with Error Correction
---	UID Read
---	Noise Measurement

Processing address (hex)	Applicable command
0000 to FFFF (Settable addresses depend on ID Tag.)	Read
	Write
	Bit Set
	Bit Clear
	Mask Bit Write
	Calculation Write
0000 to FFFF	Data Fill
0000 to FFFD	Data Check
	No. of Write Control
Read Address 0000 to FFFF	Copy
00000 to FFFA (See note.)	Read with Error Correction
	Write with Error Correction
---	UID Read
---	Noise Measurement

---: Undefined (No setting required)

---: Undefined (No setting required)

Note: The range of addresses that can be set depends on the ID Tag.

**■ Data Storage Area: Words (CIO n+4) to (CIO n+5)
(= CIO 2□□4 to CIO 2□□5)**

Word address	Meaning															
	15	14	13	12	11	10	9	8	7	6	5	4	3	2	1	0
CIO 2□□4	Data storage word (rightmost 4 digits)															
CIO 2□□5	Data storage area				Bank No.				Data storage word (leftmost 2 digits)							

Setting (hex)	Applicable Area	Bank No. (hex)	Applicable area	Leftmost 2 digits (BCD)	Rightmost 4 digits (BCD)	Applicable area
0	DM	0	DM	000000	to 032767	DM
1	CIO		CIO	000000	to 006143	CIO
2	WR		WR	000000	to 000511	WR
3	HR		HR	000000	to 000511	HR
4	AR		AR	000000	to 000959	AR
5	EM	0 to C	EM	000000	to 032767	EM
6	TIM	0	TIM	000000	to 004095	TIM
7	CNT		CNT			CNT

■ Command Option: CIO n+6 (= CIO 2□□6)

Word address	Meaning															
	15	14	13	12	11	10	9	8	7	6	5	4	3	2	1	0
CIO 2□□6	Command option															

Command option	Applicable command
---	Read
	Write
	Bit Set
	Bit Clear
Mask specified data 0000 to FFFE	Mask Bit Write
Operation data 0000 to FFFF	Calculation Write
Fill data 0000 to FFFF	Data Fill
---	Data Check
Number of writes 0000 to FFFF	No. of Writes Control
Write address 0000 to FFFF	Copy
---	Read with Error Correction
	Write with Error Correction
	UID Read
---	Noise Measurement

---: Not defined (No setting necessary.)

Degree of Protection

IP-□□ degrees of protection given in this document were confirmed by OMRON based on the test conditions given below. Confirm satisfactory sealing performance in the actual operating environment and under the actual operating conditions before use.

IP = International Protection mark

■ IEC (International Electrotechnical Commission) Standards (IEC60529: 1989-11)

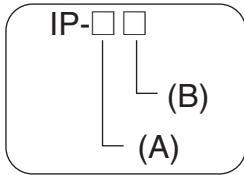









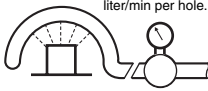

(A): First symbol: Degree of protection against solid materials

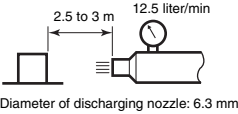
Degree	Protection	Protection
0		No protection
1		Protects against penetration of any solid object such as a hand that is 50 mm or more in diameter.
2		Protects against penetration of any solid object such as a finger that is 12.5 mm or more in diameter. Any object with a diameter of 12 mm, such as a finger, will not reach a hazardous part even if it penetrates 80 mm.
3		Protects against penetration of any solid object such as a wire that is 2.5 mm or more in diameter.
4		Protects against penetration of any solid object such as a wire that is 1 mm or more in diameter.
5		Protects against penetration of dust of a quantity that may malfunction the protect or obstruct the safety operation of the product.
6		Protects against penetration of all dust.

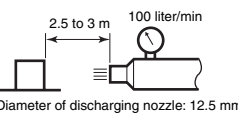
(B): Second symbol: Degree of protection against water

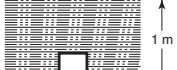
Degree	Protection	Protection	Test method (with pure water)
0	No protection	Not protected against water.	No test
1	Protection against water drops 	Protects against vertical drops of water towards the product.	Water is dropped vertically towards the product from the test machine for 10 min.
2	Protection against water drops 	Protects against drops of water approaching at a maximum angle of 15° to the left, right, back, and front of vertical towards the product.	Water is dropped for 2.5 min each (i.e., 10 min in total) towards the product inclined 15° to the left, right, back, and front from the test machine.

Degree	Protection		Test method (with pure water)
3	Protection against sprinkled water 	Protects against sprinkled water approaching at a maximum angle of 60° from vertical towards the product.	Water is sprinkled at a maximum angle of 60° to the left and right from vertical for 10 min from the test machine.  Water rate is 0.07 liter/min per hole.
4	Protection against water spray 	Protects against water spray approaching at any angle towards the product.	Water is sprayed at any angle towards the product for 10 min from the test machine.  Water rate is 0.07 liter/min per hole.
5	Protection against water jet spray 	Protects against water jet spray approaching at any angle towards the product.	Water is jet sprayed at any angle towards the product for 1 min per square meter for at least 3 min in total from the test machine.  12.5 liter/min Diameter of discharging nozzle: 6.3 mm
6	Protection against high-pressure water jet spray 	Protects against high-pressure water jet spray approaching at any angle towards the product.	Water is jet sprayed at any angle towards the product for 1 min per square meter for at least 3 min in total from the test machine.  100 liter/min Diameter of discharging nozzle: 12.5 mm
7	Protection underwater 	Resists the penetration of water when the product is placed underwater at specified pressure for a specified time.	The product is placed 1 m deep in water (if the product is 850 mm max. in height) for 30 min. 
8	Protection underwater 	Can be used continuously underwater.	The test method is determined by the manufacturer and user.

■ Oil resistance (OMRON in-house standard)

Protection	
Oil-resistant	No adverse affect from oil drops or oil spray approaching from any direction.
Oil-proof	Protects against penetration of oil drops or oil spray approaching from any direction.

Note: This OMRON in-house standard confirms resistance to cutting and other oils. It is equivalent to the former JEM standard.

Revision History

A manual revision code appears as a suffix to the catalog number at the bottom of the front and rear pages.

Cat. No.: Z271-E1-02B

↑
Revision code

Revision code	Date	Revised contents
01	December 2007	Original production
02	August 2010	Added information for Heat-resistive Tags (V680-D1KP58HTN and V680-D1KP58HT). Added information on Tag memory setting and data transfer setting. Made other minor corrections.
02A	December 2010	Minor corrections (p.67, 95)
02B	May 2011	Minor corrections (p.150)

OMRON Corporation Industrial Automation Company
Tokyo, JAPAN

Contact: www.ia.omron.com

Regional Headquarters

OMRON EUROPE B.V.

Sensor Business Unit

Carl-Benz-Str. 4, D-71154 Nufringen, Germany
Tel: (49) 7032-811-0/Fax: (49) 7032-811-199

OMRON ELECTRONICS LLC

One Commerce Drive Schaumburg,
IL 60173-5302 U.S.A.
Tel: (1) 847-843-7900/Fax: (1) 847-843-7787

OMRON ASIA PACIFIC PTE. LTD.

No. 438A Alexandra Road # 05-05/08 (Lobby 2),
Alexandra Technopark,
Singapore 119967
Tel: (65) 6835-3011/Fax: (65) 6835-2711

OMRON (CHINA) CO., LTD.

Room 2211, Bank of China Tower,
200 Yin Cheng Zhong Road,
PuDong New Area, Shanghai, 200120, China
Tel: (86) 21-5037-2222/Fax: (86) 21-5037-2200

Authorized Distributor:

© OMRON Corporation 2007 All Rights Reserved.
In the interest of product improvement,
specifications are subject to change without notice.

Cat. No. Z271-E1-02B

Printed in Japan

1210