

- 24 VDC input voltage
- Number of connectable antennas - 1 channel
- DIN rail or M4 screw mounting
- -25°C to 65°C storage temperature
- -10°C to 55°C operation temperature
- Operates at 125 kHz
- Controller reset input function
- Rugged polycarbonate resin construction
- Added functions:



- **Selective access:** A function that allows communications with a specific data carrier that is among multiple data carriers, within the communications area.
- **Multi-trigger with communications end code:** A function that notifies the host when communications with all data carriers within the communications area has completed.
- **Data lock:** This function permanently disables the overwriting of data on the data carrier.
- **Serial number readout:** A function that reads the factory assigned data carrier serial number.
- **Master/slave controller switching from host unit:** A function that allows the host to set the master/slave controller settings.

Ordering Information

■ RS-485 RFID CONTROLLER

Item	Description		Part number
RFID controller	Type	Electromagnetic inductive	V700-CD2D-V2
	Interface	RS-485	

Specifications

■ GENERAL

- The communications distance priority mode or communications time priority mode can be set on the serial interface ID controller or ID sensor unit via the communications mode DIP switches.
- The communications distance priority mode is always used for parallel interface ID controllers.
- These specifications are the certified performance when taking into consideration variations in ambient temperatures and products.

■ CONSTRUCTION

Material	Polycarbonate resin
Enclosure rating	Inner-panel installation

■ COMMUNICATIONS

Part number	V700-CD2D-V2
Interface	RS-485
Communications method	EIA RS-485, 1-to-N 2 wires half duplex
Synchronous method	Start-stop sync with 1 or 2 stop bits
Synchronous connection	Communicate with up to 31 controllers
Baud rate	4800 bps, 9600 bps, 19200 bps or 38400 bps
Transmission code	ASCII (7 bits) or JIS (8 bits)
Error detection (See Note.)	Vertical parity (even, odd or none) Horizontal parity as BCC
Path length	500 m max.
Reset input function	External controller reset
Programming console port	Interfaces with Omron C200H-PRO27-E

Note: 1. When setting the operating parameters via DIP switches, be sure to use the supplied screw driver or a similar non-metal tool.
2. Wind the supply power and ground wires together and install a ferrite core. Separate the ferrite core 10 cm from the controller.

■ RATING

Supply voltage	24 VDC (+10%/-15%)	
Power consumption	20 W max.	
Protective conductor	—	
Reset input specification	Input voltage	24 VDC
	Input impedance	2.2 kΩ
	Input current	10 mA typ. (24 VDC)
	On voltage	19 V min.
	Off voltage	5 V max.
	Input speed	70 ms max.

■ RESET CIRCUIT DIAGRAM

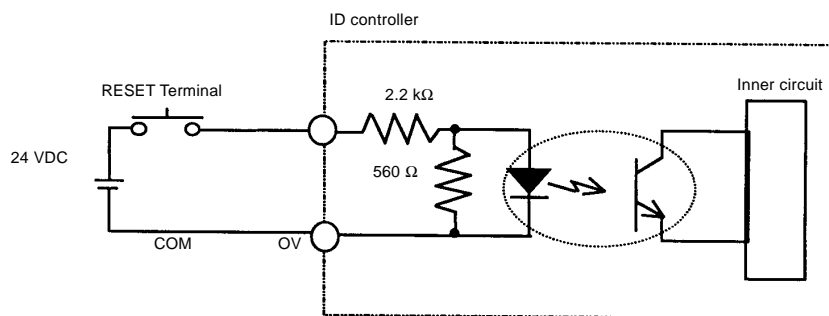

Note: When RESET input is on, the CPU stops the operation.

■ OPERATION INDICATORS

Number	Indicators	Function	Description
1	RUN: green	Run indication	Turns ON when the controller is in normal operation.
2	COMM: green	Operation indication	Turns ON when the controller is in communications with the tag.
3	NORM: green	Communication complete indication	Turns ON/OFF once when the communications finish with no error.
4	ERR: red	Error indication	Turns ON/OFF once if a communications error results. Turns on if a system error results.

■ CHARACTERISTICS

Insulation resistance	Between power terminal and protective conductor terminal	20 M min. (with 100 VDC megger)
	Between power terminal and protective input/output terminal	
	Between power terminal and casing	
	Between input/output terminal and protective conductor terminal	
	Between input/output terminal and casing	
	Between protective conductor terminal and casing	
Withstand voltage	500 VAC, 50/60 Hz, 1 min., current leak 10 mA max.	
Vibration resistance-destruction	10 to 150 Hz, 0.3 mm double amplitude 4 times for 8 minutes each in X, Y and Z directions	
Shock resistance-destruction	150 m/s ² ; 3 times each in X, Y and Z directions	
Applied standard	EN50081-2, EN50082-2, FCC part 15 subpart B	

Note: Specification conditions: ambient temperature 23°C, 65% relative humidity.

■ STORAGE CONDITIONS

Ambient temperature	-25°C to 65°C (no icing)
Ambient humidity	35% to 95% relative humidity (no condensation)
Environment	Do not subject to corrosive gas such as explosive gas, inflammable gas, or organic solvent or salt conditions. Do not place in dusty area.

■ OPERATION CONDITIONS

Ambient temperature	10°C to 55°C (no icing)
Ambient humidity	35% to 85% relative humidity (no condensation)

Dimensions

Unit: mm (inch)

■ V700-CD2D-V2

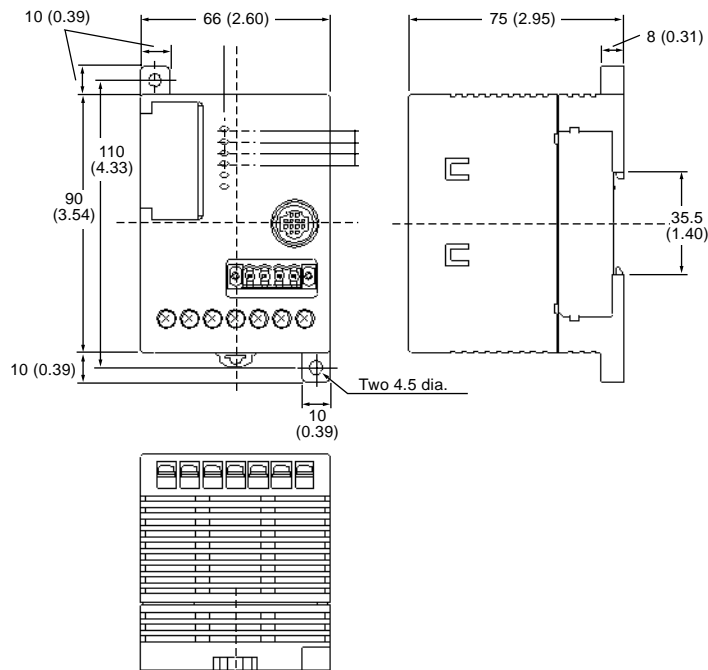

Installation

ENVIRONMENT

Product installs using DIN rail or M4 screws.

- Provide enough space around the controller for ventilation
- Avoid setting up the unit near a highly heat-generating device (such as heater, transformer and large-capacity resistor.)

Do not install in places where:

- the temperature varies heavily
- the humidity is high or condensation is present
- the antenna may get splashed with water, oil, chemicals or organic solvents
- the antenna is exposed to corrosive gases
- a noise-generating source is nearby

Do not install the product around noise sources. The received noise level can be confirmed with the programming console. Make sure to use after checking the noise level.

CONNECTION OF RS-485 INTERFACE

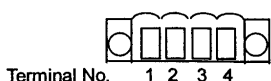

Terminal No.	1	2	3	4
Polarity	+	-	+	-

*Pins 1 and 3, and 2 and 4 are internally short-circuited in RS-485 controller.

1-to-N System Configuration

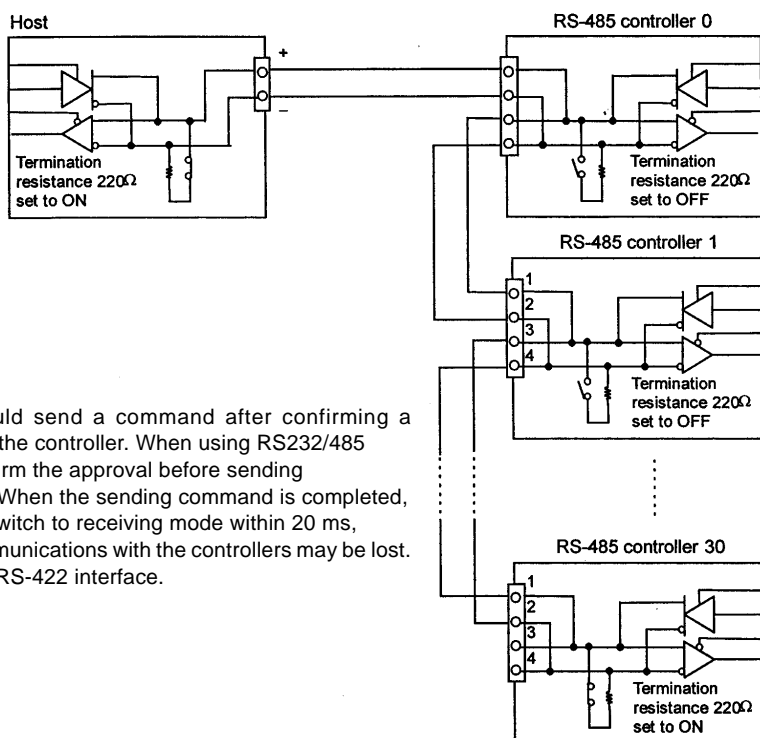

Note: The host should send a command after confirming a response from the controller. When using RS232/485 converter, confirm the approval before sending the command. When the sending command is completed, make sure to switch to receiving mode within 20 ms, otherwise communications with the controllers may be lost. Do not use an RS-422 interface.



OMRON ELECTRONICS LLC.
 One East Commerce Drive
 Schaumburg, IL 60173
1-800-55-OMRON

OMRON ON-LINE
 Global - <http://www.omron.com>
 USA - <http://www.omron.com/oei>
 Canada - <http://www.omron.com/oci>

OMRON CANADA, INC.
 885 Milner Avenue
 Scarborough, Ontario M1B 5V8
416-286-6465