

Distance-settable Photoelectric Sensor with Background Suppression and Visible Laser Light Beam

- Reliable background suppression detection, even of shiny objects
- Detection of objects regardless of color
- Small objects can be detected
- Immune to ambient light
- Sensing distance adjustable from 150 ... 700 mm
- Easy adjustment by a 6-turn-screw
- Laser class II according to EN 60 825 ($< 1 \text{ mW}_{\text{eff.}}$)
- Conformity to EN 60 947-5-2



Ordering Information

■ Distance-settable Photoelectric Sensor

Sensing method	Appearance	Connection method	Sensing distance	Output function	Model	
					NPN output	PNP output
Laser-sensor with background suppression		Pre-wired connector		Light ON/Dark ON programmable	F3C-AL14-M1J	F3C-AL44-M1J

■ Accessories (Order Separately)

Mounting Bracket

Shape	Model	Applicable model
	E39-L40	F3C-AL□4-M1J

Sensor I/O Connectors

Cord	Shape	Cable type	Model
Standard	Straight	Four-wire type	XS2F-D421-D80-A
			XS2F-D421-G80-A
	L-shaped		XS2F-D422-D80-A
			XS2F-D422-G80-A
Vibration-proof robot cable	Straight		XS2F-D421-D80-R
			XS2F-D421-G80-R
	L-shaped		XS2F-D422-D80-R
			XS2F-D422-G80-R

Application Examples

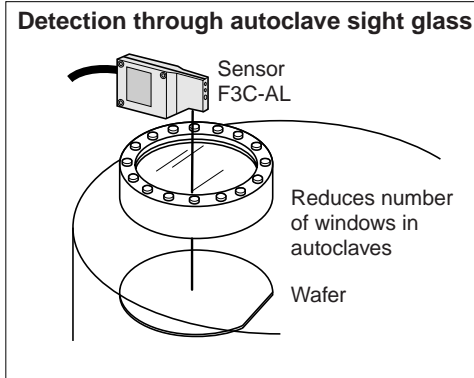
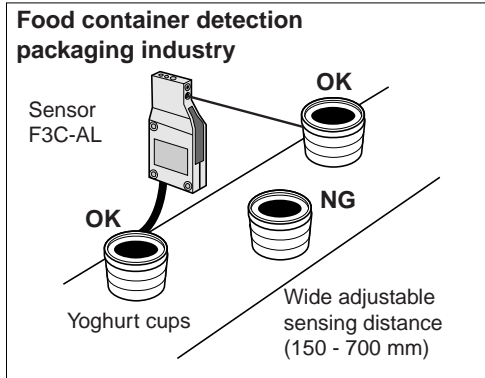

Specifications

■ Ratings

Item	F3C-AL□4-M1J
Power supply voltage	10 ... 30 VDC; including 10 % (p-p) ripple
Current consumption	30 mA max.
Rated sensing distance range	120 to 700 mm (white paper, 90 % refl., 100 x 100 mm)
Setting distance range	150 to 700 mm (white paper, 90 % refl., 100 x 100 mm)
Hysteresis	2 % max. of adjusted sensing distance (90 % refl.)
Black-/white-error	10 % max. (of rated sensing distance, 90 % / 6 % reflectivity)
Blind zone	< 120 mm (90 % reflectivity)
Response time	≤ 10 ms max. operation or reset
Power on reset time	300 ms
Spot size	1,5 mm x 4 mm typ. at 700 mm sensing distance
Output current	150 mA max. at 30 VDC
Voltage drop	< 2,0 VDC
Ambient light immunity	Incandescent light < 5.000 lx, sun light < 5.000 lx
Ambient temperature range (operation)	0°C ... + 50°C (no icing or condensation)
Ambient temperature range (storage)	-25°C ... + 60°C (no icing or condensation)
Ambient humidity	35 % ... 85 % rh (with no condensation)
Vibration resistance	Destruction: ± 0,75 mm, 10 Hz – 70 Hz, 5 min. cycle time
Shock resistance	Destruction: a = 500 m / s ² , 18 ms, 3 axis, 6 shocks
Isolation resistance	> 20 MΩ (1000VDC)
Dielectric strength	500 VAC, 50/60 Hz (1 min. duration time)
Degree of protection	IP 40

■ Characteristics

Item	F3C-AL□4-M1J
Light source	Pulsed red light semiconductor laser Class II: < 1mWeff. / 670 nm / 5 % duty cyle (Impulse time: 60 μs, Period time: 1,2 ms)
Adjustment of sensing distance	6-turn-screw
Terminals / cable length / diameter of wires	M12-plug / 200 mm / 4 x 0,34 mm ² (PVC cable)
Connections	1 / bn = + VCC 3 / bu = OV 2 / wt = Lon/Don-selection 4 / bk = Control output
Control output	PNP or NPN, open collector output
Function	Light ON / Dark ON, programmable by wiring of Pin 2
Circuit protection	short-circuit, overload and reverse polarity
Light indication	Red LED on = laser light received
Stability indication	Green LED on = Stable on-/off condition
Optical output power regulation	Automatic Power Control
Dimensions	90 mm x 18/8 mm x 45 mm (Height / width / depth)
Housing- / Optic-material	Housing: Makrolon Lenses: Acrylic (PMMA)
Weight	60 g
Accessories	Screwdriver, instruction manual

Engineering Data (Typical)

■ F3C-AL

Black/White-Error

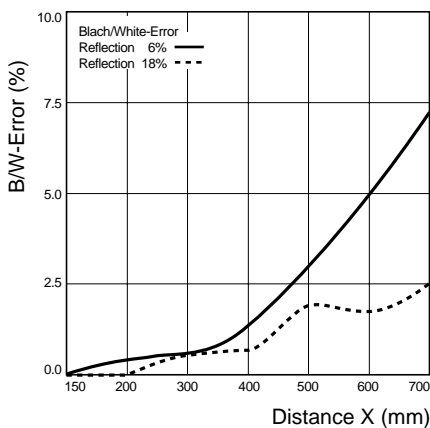

Close-range Characteristics (Blind zone)

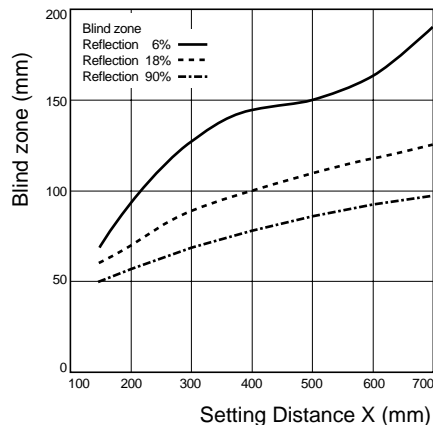

Hysteresis

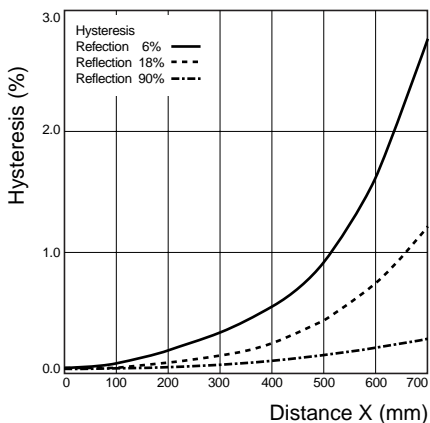

Operation

■ Output Circuits

NPN/PNP Selection

Output configuration	Model	Output transistor status	Timing chart	Wiring Pin ② (mode selection)	Output circuit
NPN	F3C-AL14-M1J	Light ON		Pin ② connected to Pin ① (Light ON) or not connected	<p>Connector Pin Arrangement</p>
		Dark ON		Pin ② connected to Pin ③ (Dark ON)	<p>Connector Pin Arrangement</p>
PNP	F3C-AL44-M1J	Light ON		Pin ② connected to Pin ① (Light ON)	<p>Connector Pin Arrangement</p>
		Dark ON		Pin ② connected to Pin ③ (Dark ON) or not connected	<p>Connector Pin Arrangement</p>

Structure of Sensor I/O Connector

Classification	Wire colour	Connector pin No.	Use
DC	Brown	①	Power supply (+V)
	White	②	Mode selection Lon/Don
	Blue	③	Power supply (0 V)
	Black	④	Output

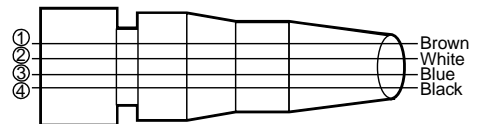
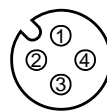

XS2F-D42□-D80-□
XS2F-G42□-G80-□

■ Sensitivity Adjustment

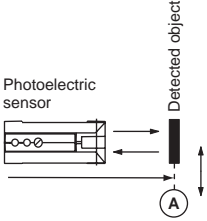
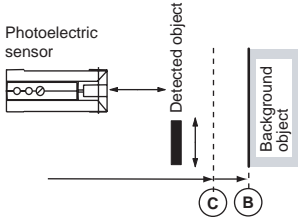
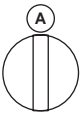
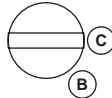
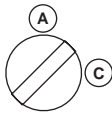
Item	Position A	Position B and C	Setting
<p>Adjustment procedure</p>	<p>Place the detected object at the desired location and turn the LIGHT indicator (red) lights. This is position A</p>	<p>Background object Remove the detected object and turn the adjustment knob clockwise until the LIGHT indicator (red) lights. This is the position B. Then turn the adjustment knob counter-clockwise until the LIGHT indicator (red) goes out. This is position C. No Background object The maximum adjustment setting is used as position C.</p>	<p>Set the adjustment to halfway between A and C. Confirm that the STAB indicator (green) remains lit both with the detected object present and not present. If the STAB indicator does not remain lit, review the detection method to enable stable operation.</p>
<p>Detecting condition</p>			
<p>Status of distance setting knob</p>			
<p>Indicators</p>	<p>OFF <input type="radio"/> STABILITY (green) ON <input checked="" type="radio"/> LIGHT (red)</p>	<p>OFF <input type="radio"/> STABILITY (green) OFF <input type="radio"/> LIGHT (red)</p>	<p>ON <input checked="" type="radio"/> STABILITY (green) OFF <input type="radio"/> LIGHT (red)</p>

Dimensions Note: All units are in millimeters unless otherwise indicated

■ Sensor and Accessories

Distance-settable Photoelectric Sensor F3C-AL

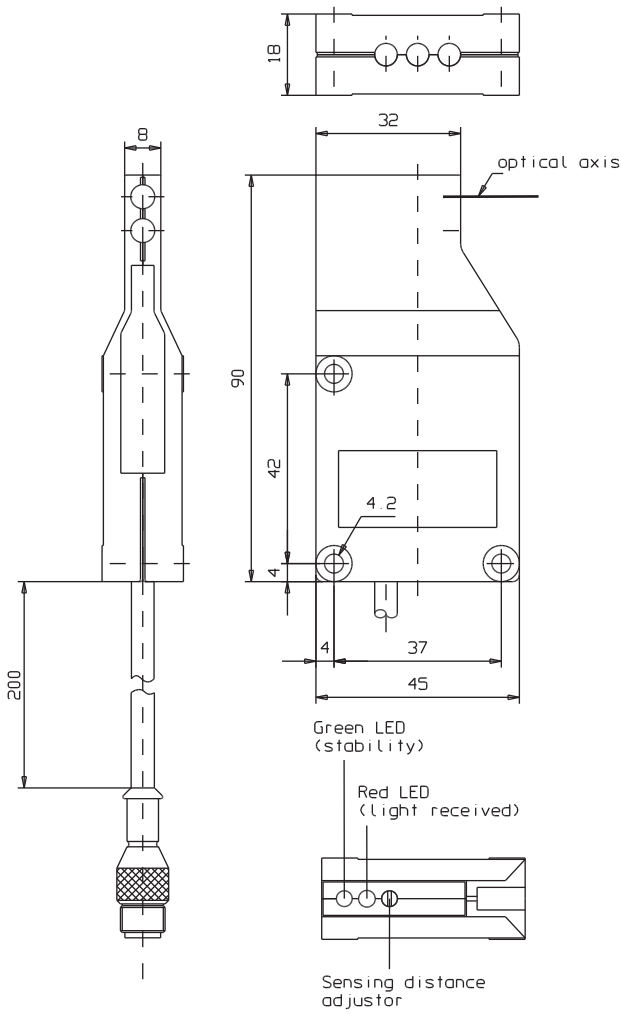

Mounting Bracket E39-L40 (Order Separately)

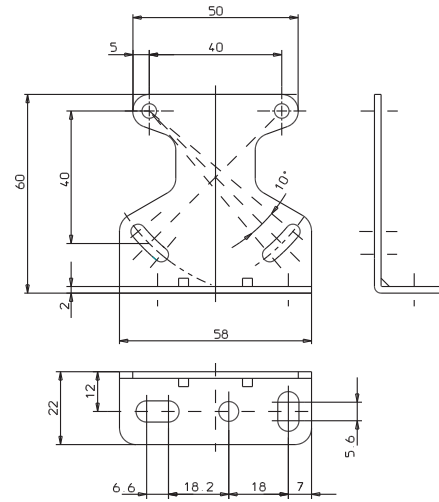

■ Safety Precaution



Laser beam!

Laser protection class 2
Do not look into the laser beam.
Pay attention to the accident prevention regulations
and the laser protection class.

Visible laser emission!

Avoid any indirect or direct radiation of
reflected or emitted laser light!

■ Special hints

Recommended adjustment

To assure stable working conditions the green stability LED should be always turned on.

The green LED displays two stability conditions:

1. Output stable ON (red LED on)
2. Output stable OFF (red LED off)

Best performance can be achieved if the sensing object is located closer than -10 % of the setting distance or the shiny background is fixed +10 % behind the switching position.

Correct operation

The moving direction of the sensor or object should be preferably along the optical axis of the light beam. Lateral approach is also possible. Movement from the top to the bottom or opposite can cause malfunction and should be avoided.

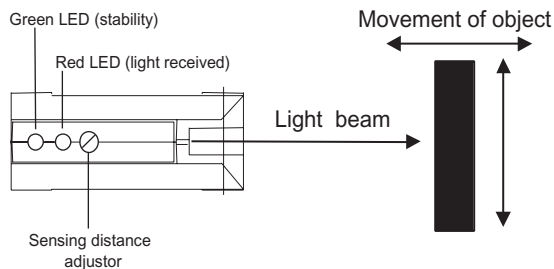

Where two sensors are installed opposite each other, their optical axis should be disaligned to prevent any mutual interference.

Avoid influences of any strong ambient light sources that can decrease the sensitivity of the sensor or cause instable working condition.

Connections and precautions

If the input/output lines of the photoelectric sensor are placed in the same conduit or duct as power lines or high-voltage lines, the photoelectric sensor could malfunction, or even be damaged by electrical noise. Either separate the wiring or use shielded lines as input/output lines to the photoelectric sensor.

The cord connected to the Sensor can be extended up to 50 m provided that the diameter of each wire is 0,3 mm² minimum.

Maintenance

Clean the optical surface from time to time by using a soft cloth.

Startup Operation

A maximum of 300 ms is required from the time power is turned on until F3C is able to detect objects. If power is supplied to the loads and the F3C from different sources, turn on power to the F3C first.

Water resistivity

Do not use F3C in water, in rain or outdoors.

ALL DIMENSIONS SHOWN ARE IN MILLIMETERS.
To convert millimeters into inches, multiply by 0.03937. To convert grams into ounces, multiply by 0.03527.

Cat. No. E510-E2-1 **In the interest of product improvement, specifications are subject to change without notice.**

OMRON EUROPE B.V.

Sensor Business Unit
Carl-Benz-Strasse 4
D-71154 NUFRINGEN
Germany
Telephone +49-7032-811-0
Telefax +49-7032-811-199

Printed in Germany
0301